

# SUNRISE POWERLINK

Sunrise Powerlink Construction Yard  
**Construction Lighting Mitigation Plan**

**Mitigation Measure V-1b**

January 12, 2011

Revised June 22, 2011

TABLE OF CONTENTS

1.0 BACKGROUND ..... 1  
2.0 OBJECTIVES ..... 2  
    2.1 LIGHTING DESIGN ..... 2  
    2.2 LIGHTING BRIGHTNESS..... 3  
    2.3 LIGHTING OPERATION ..... 3  
3.0 WORK DESCRIPTION ..... 3  
4.0 LIGHTING REQUIREMENTS..... 4  
    4.1 CONSTRUCTION OPERATIONS..... 4  
    4.2 SECURITY OPERATIONS ..... 6  
5.0 LIGHTING DESIGN ..... 6  
6.0 APPLICABLE MITIGATION MEASURE..... 8

**APPENDIX A** Sunrise Powerlink Project Alignment: Construction Yard Locations

**APPENDIX B** Construction Yard Outdoor Lighting and Fixture Design

**APPENDIX C** Night Construction Addendum

**APPENDIX D** Coordination Documentation

## 1.0 BACKGROUND

The Sunrise Powerlink Project (Project) includes approximately 118 miles of new overhead transmission line construction in southern San Diego County and a portion of Imperial County for San Diego Gas and Electric (SDG&E). The Project begins at the Imperial Valley Substation and travels west to the Sycamore Substation on the Marine Corps Air Station (MCAS): Miramar, and will consist of (1) 500 kV EHV (Extra High Voltage) transmission interconnect from Imperial Valley Substation to the Suncrest Substation in Alpine and (2) 230 kV EHV transmission interconnects from the Suncrest Substation to the Sycamore Substation. The underground portion of the Sunrise Powerlink consists of a buried 230 kV double circuit underground system in Alpine, CA.

The purpose of this plan is to document SDG&E's compliance with Mitigation Measure V-1b of the final Environmental Impact Report (EIR) approved for the Sunrise Powerlink Project. Mitigation Measure V-1b, "Reduce Construction Night Lighting Impacts," states the following: "SDG&E shall design and install all lighting at construction and storage yards and staging areas and fly yards such that light bulbs and reflectors are not visible from public viewing areas; lighting does not cause reflected glare; and illumination of the project facilities, vicinity, and nighttime sky is minimized." The full text of Mitigation Measure V-1b can be found in Section 6.0 of this document.

This Construction Lighting Mitigation Plan (Plan) has been designed to address the aforementioned visual concerns associated with activities at temporary construction yards and present the design and implementation of lighting for these temporary construction yards. SDG&E is submitting this Plan for construction activities that will occur during established construction work hours by the local ordinance at the following Project construction yards: Sycamore Estates, Hartung, Helix, Wilson, SWAT, Bartlett/Hauser, Barrett Canyon, Kreutzkamp, Jacumba Valley, Thing Valley (in the Cleveland National Forest), McCain Valley, AER, BLM/S2, Plaster City, Dunaway, IV Sub, and Thomas (Appendix A). In the event that additional Project construction yards are obtained through the variance process, this Construction Lighting Mitigation Plan would apply to those yards as well.

In addition, nighttime lighting will be required for construction activities outside those established by the local ordinance based on coordination with the local jurisdiction at the following yards: IV Substation, Dunaway Yard, Plaster City Yard, and S2 Yard for construction activities outside of daylight hours. SDG&E has and will continue to coordinate with the local jurisdictions to obtain approvals and/or variances to perform

construction activities outside the schedule established by the respective local agencies. Currently, SDG&E anticipates requiring lighting for construction activities between midnight and dawn in Imperial County (between Imperial Valley Substation and structure EP290). For the purposes of this revision, SDG&E has included within the context of this Plan, anticipated night-time construction activities along the Right-of-Way within Imperial County. The same or comparable light fixtures will be used along the Right-of-Way and in the yards.

## **2.0 OBJECTIVES**

The intention of Mitigation Measure V-1b is to reduce the visual impacts associated with temporary nighttime construction lighting by reducing the overall effect of sky glow (light wastefully escaping into the night sky), glare (light shining towards public roadways), and light trespass (light shining towards locations it is not intending to illuminate). During the use of Construction Yards, activities within those yards could potentially be seen by visual receptors in close proximity to the construction yards. The aforementioned properties are within “public use areas” and these receptors can include, but are not limited to, nearby residents, commercial operators, and travelers on public roads. A secondary objective of this plan is to promote lighting efficiency so that nighttime lighting impacts, even for temporary operations such as those addressed in this Plan, are minimized or reduced.

Both of these objectives can be met by implementing the three key components of this plan: lighting design, lighting brightness, and lighting operation.

### **2.1 LIGHTING DESIGN**

Temporary construction lighting will be hooded. Hooded is defined as: “a shield that limits the light so that the backscatter to the nighttime sky is minimized.” All of the proposed lighting for the construction yards will be hooded so that the light or lights will be directed light towards the work area and the design of the lights will be pointed downward or directed away from sensitive receptors. The illumination area will be localized to where work is taking place. The design of the lighting allows for the illumination component to be raised or lowered as the circumstance requires. This allows for the screening of excess lighting by modifying the final height of the lighting array. An example of the hood and the proposed lighting design is provided in Appendix B.

## **2.2 LIGHTING BRIGHTNESS**

Lighting brightness will be limited to the minimum brightness needed for worker safety for the activity in question. This minimum required brightness will be differentiated between two types of activities: construction operations (including emergency operations) and security operations. Further information regarding the types of lighting units proposed for these two operations, including brightness standards, is provided in Section 5.0.

## **2.3 LIGHTING OPERATION**

Areas requiring high illumination, such as those that are lit for construction operations, will be operated such that the lights are not left on during periods of inactivity at the yards. All proposed lighting will have either a motion sensor or an “on-off” switch, so that the light can be turned off when illumination is unnecessary. Seasonal changes in sunrise and sunset will result in a varied need for lighting. Lights will only be used as needed and will be off during daylight hours.

## **3.0 WORK DESCRIPTION**

Construction of the Project will require the use of the 17 construction yards described in Section 1.0 as a key project component. Use of the yards will include, but is not limited to, activities such as: equipment and materials staging, structure assembly, personnel meetings and tailboards, administrative tasks, helicopter landing and staging, and equipment and helicopter fueling. Additionally, SDG&E may use yards for safety of flight or emergencies requiring maintenance/repair that necessitate immediate landing of aircraft and potential grounding of the aircraft until a repair is complete. The exact number and type of activities that are proposed for individual yards are detailed in the request specifics for the appropriate NTPs. The proposed need for Construction Yard lighting during work hours as established by the local ordinance is to ensure safe work site illumination during construction activities and for emergency response, which has the potential to occur at any yard, therefore this request is universal for all yards, regardless of the specific activities occurring therein. Helicopters may also require the use of light structures for emergency helicopter maintenance, and there may be times when security lighting will be necessary for the safety of personnel and equipment.

SDG&E intends to perform some night-time construction activities in Imperial County between structures EP290 and the existing Imperial Valley Substation, including the S2 Construction Yard, Plaster City Construction Yard, Dunaway Construction Yard, and the

Imperial Valley Substation Construction Yard. Summertime temperatures in the Imperial Desert can exceed 120 degrees Fahrenheit, potentially endangering worker safety if construction is performed during these peak hours. This increases the potential for heat exhaustion or heat stroke, and for contact with sun-heated steel components. Coordination documentation with Imperial County is included as Appendix D. SDG&E coordinated with the Supervising Border Agent, Michael Hulseby with the United States Customs and Border Protection in Imperial Valley on June 3 and June 6, 2011 and will continue to coordinate with this agency throughout construction.

Where activities will occur outside of daylight hours in Imperial County, as established by coordination with the local jurisdiction, use of the yards (IV Substation Yard, Dunaway Yard, Plaster City Yard, and S2 Yard) will include receiving tower steel components via flatbed truck and trailer, assembling the structure (tower) by use of forklifts and smaller cranes (30-ton), and Quality Control inspections. An addendum to this Lighting Plan is included as Appendix C which highlights work practices for construction at night. The yards will be watered as needed to remain in compliance with the Project Dust Control Permit.

Along the Right-of-Way in Imperial County, where construction activities will occur outside of daylight hours in Imperial County, as established by coordination with the local jurisdiction (EP290 through EP363-1; excluding locations within Peninsular Bighorn Sheep Area), actions will include steel assembly and erection at conventional tower sites, steel and rebar hauling and delivery, rebar assembly and placement at conventional tower sites, and foundation activities at conventional tower sites. The Right-of-Way will be watered as needed to remain in compliance with the Project Dust Control Permit.

## **4.0 LIGHTING REQUIREMENTS**

### **4.1 CONSTRUCTION OPERATIONS**

Construction Operations can include any of the following: lighting for safe emergency response procedures; lighting for general construction activities to take place in the yard during approved operational hours; lighting for receiving and assembling tower structures from midnight to dawn in Imperial County. For these activities, SDG&E intends to use portable light towers with integrated generators, and will place one or two portable light tower units at each of the identified construction yards.

For general construction activities, light towers will be used when activities or maintenance within the yards require illumination for safety or necessary operations during a period of normal operational times. Normal operational times are generally defined as the hours of 7 am until dawn, and dusk to 7pm, or as otherwise approved by the local jurisdiction. The construction foreman in charge of supervision of yard activities, or their designee, will be responsible for ensuring that yard lighting is shut off when activities cease or lighting is no longer needed (e.g. dawn). In addition to the guidelines of Mitigation Measure V-1b, SDG&E will comply with the construction time constraints for each yard to ensure compliance with the local noise ordinances or as otherwise approved by the local jurisdiction, and construction yard light plant activity will be limited to the required use period.

For construction activities at IV Substation Yard, Dunaway Yard, Plaster City Yard, and the S2 Yard and along the Right-of-Way within Imperial County, light towers will be used for construction activities outside of daylight hours. Work in these areas will occur between midnight through 10 am during the months when the Imperial desert temperatures reach extremes and put workers' safety at risk (June-August). It is anticipated that only six of these hours will require lighting for steel deliveries, tower assembly, foundations, and Quality Control inspections.

For all construction operations except aircraft emergency repairs, SDG&E and its contractor will use portable light towers with integrated generators at the identified construction yards. The lighting source model will be a Terex Amida AL-4000, or comparable (see Appendix B). For aircraft emergency repairs, the lighting source model will be a Husky Twin Head Halogen Work Light, or comparable.

Lighting for safe emergency response procedures includes emergency repairs related to mechanical problems requiring an aircraft to immediately land, which may necessitate illumination of the immediate area of the aircraft. These emergency repairs must be completed before the aircraft can be moved and therefore nighttime work may occur to complete these repairs. The lighting will focus on the immediate work area to minimize reflected glare and the illumination of the nighttime sky. The aircraft mechanic will determine the minimum required use period for completion of the emergency repairs, and will ensure that lighting is turned off when no longer required. For all other emergency response activities, such as those necessitated by an immediate threat to human safety or the environment, the minimum required use period would be determined by the safety officer or environmental representative in charge of the emergency response. Once the immediate threat to human safety or the environment

has been mitigated, the remainder of the response work would only continue after consultation with the appropriate jurisdictional land agents.

Light plants will only be illuminated when needed. As per Mitigation Measure V-1b, light bulbs and reflectors will not be visible from public viewing areas, lighting will not cause reflective glare, light fixtures will be oriented to direct light downward to minimize back-scatter, and light towers will produce the minimum brightness necessary for worker safety. The lighting will focus on the immediate work area to minimize reflected glare and the illumination of the nighttime sky.

Design of both of the aforementioned light towers and light structures is included in Appendix B of this Plan with as well as an example of the hooding that will limit the backscatter from the lights.

Demobilization of these yards will include removal of all temporary lighting at the identified construction yards. All crews and construction personnel will be instructed on the proper lighting procedures, and of their responsibilities under the Mitigation Measures and other established Project procedures.

## **4.2 SECURITY OPERATIONS**

When it is necessary to use security lighting, SDG&E and its contractor will use temporary security light towers. The model will be a CamGuard Security Tower, patented device.

Light towers for security will be at least 25' high for visibility with a 2.5 ton cement base for stability. Outdoor light fixtures (luminaire) will be shielded, focused or constructed so that light rays project below a horizontal plane passing through the lowest light-emitting point of the fixture. Lighting devices shall be mounted on the tower and shall be LED type, halogen or LPS type luminaries as required by the application.

As designed, the security lighting described above will meet the requirements of mitigation measure V-1b. Lights will remain active throughout the night for security purposes as necessary. Security lights were designed to minimize illumination and back scatter to the extent feasible.

## **5.0 LIGHTING DESIGN**



The specifications for the light towers used for construction operations on the Project are as follows:

- Each of the 4 conical hooded lamps has a generation capacity of 1,000 watts of light per individual fixture with 4,000 watts of light generation total capacity. The hooding will be in place at all times.
- Individual light units may be used in any combination of 1 to 4 lights active at a time.
- The light plant, with all 4 light units active, generates ~440,000 lumens.
- The light towers can illuminate 7.5 acres or less, based on the number of active light fixtures in use and the extension height of the lights.
- The units each generate power through a 13.6 or 14.3 horsepower diesel engine.

Additional considerations for minimizing intrusive light on this unit:

- Area of illumination can be minimized if the unit is not extended to its full height (e.g. extending the unit to a height of 20 feet instead of 30).
- Area of illumination can be minimized if only a portion of the light units are active (e.g. with 2 light units active, the unit would generate approximately half the lumens, or 220,000).
- Area of illumination can be specifically directed towards the activity in question (e.g. the lights will be faced downward, and directed away from sensitive viewing areas such as public roads and residences).
- Temporal allotment for illumination can be reduced by minimizing use to only the required time period, as defined above, but generally not more than one or two hours per day, if at all (e.g. during normal operational times)
- Intrusive value of the light can be minimized by its period of use (e.g. hours near dawn or dusk, when the light is most commonly anticipated to be used, are less intrusive than times of complete night sky darkness).
- Overall light nuisance is reduced in consideration of the temporary nature of the unit's use (e.g. it will only be used during the period of time that construction operations are actively ongoing in the yard, anticipated between a few months to one year in duration).

The specifications for the light structures used for emergency helicopter maintenance are as follows:

- Up to 1,200-Watt Halogen light generation total capacity
- Up to 76 inch height
- Structure allows for quick release of lighting from tripod allowing for portable use (Clamp/Hand-held)

The specifications for temporary security towers used for security operations are as follows:

- Security towers shall consist of a base, a tower and device platform.
- Base – at least 2,500 pounds and of sufficient strength to prevent tipping in winds up to 75 mph.
- Tower – steel and at least 25 feet in height.
- Lighting devices shall be mounted to the tower and shall be either LED, halogen, or LPS type luminaires.

Appendix A shows the Project Alignment and construction yards proposed for use. Since the proposed light units are mobile and will serve the same purposes at each yard, this plan is considered universal for the named construction yards and therefore will be applicable in the event that any additional project yards are identified and approved for use by the appropriate agencies. While general this plan will be modified as appropriate for specific yard locations. Appendix B provides the design of the proposed lighting units.

In compliance with mitigation measure L-1a, SDG&E has identified a public liaison and a toll-free hot line (877-775-6818), to respond to concerns of neighboring property owners related to construction disturbances. Contact information for the public liaison person is included in the construction notices. SDG&E will respond to complaints in a timely manner. SDG&E will log the complaint, notify the CPUC of the complaint, and provide documentation to the CPUC that the complaint was effectively resolved.

## **6.0 APPLICABLE MITIGATION MEASURE**

V-1b: Reduce construction night lighting impacts.	Design and install lighting to avoid night lighting impacts.	SDG&E shall design and install all lighting at construction and storage yards and staging areas and fly yards such that light bulbs and reflectors are not visible from public viewing areas; lighting does not cause reflected glare; and illumination of the project facilities, vicinity, and nighttime sky is minimized.
--	---	--

Submit a Construction Lighting Mitigation Plan 90 days prior to construction. SDG&E shall submit a Construction Lighting Mitigation Plan to the BLM (only if on BLM lands), Forest Service (only if on National Forest lands), Anza-Borrego Desert State Park (for Park lands) and CPUC (for all areas) for review and approval at least 90 days prior to the start of construction or the ordering of any exterior lighting fixtures or components, whichever comes first. SDG&E shall not order any exterior lighting fixtures or components until the Construction Lighting Mitigation Plan is approved by the reviewing agency. The Plan shall include but is not necessarily limited to the following:

- Lighting shall be designed so exterior light fixtures are hooded, with lights directed downward or toward the area to be illuminated and so that backscatter to the nighttime sky is minimized. The design of the lighting shall be such that the luminescence or light sources is shielded to prevent light trespass outside the project boundary
- All lighting shall be of minimum necessary brightness consistent with worker safety
- High illumination areas not occupied on a continuous basis shall have switches or motion detectors to light the area only when occupied

APPENDIX A

Sunrise Powerlink Project Alignment: Construction Yard Locations

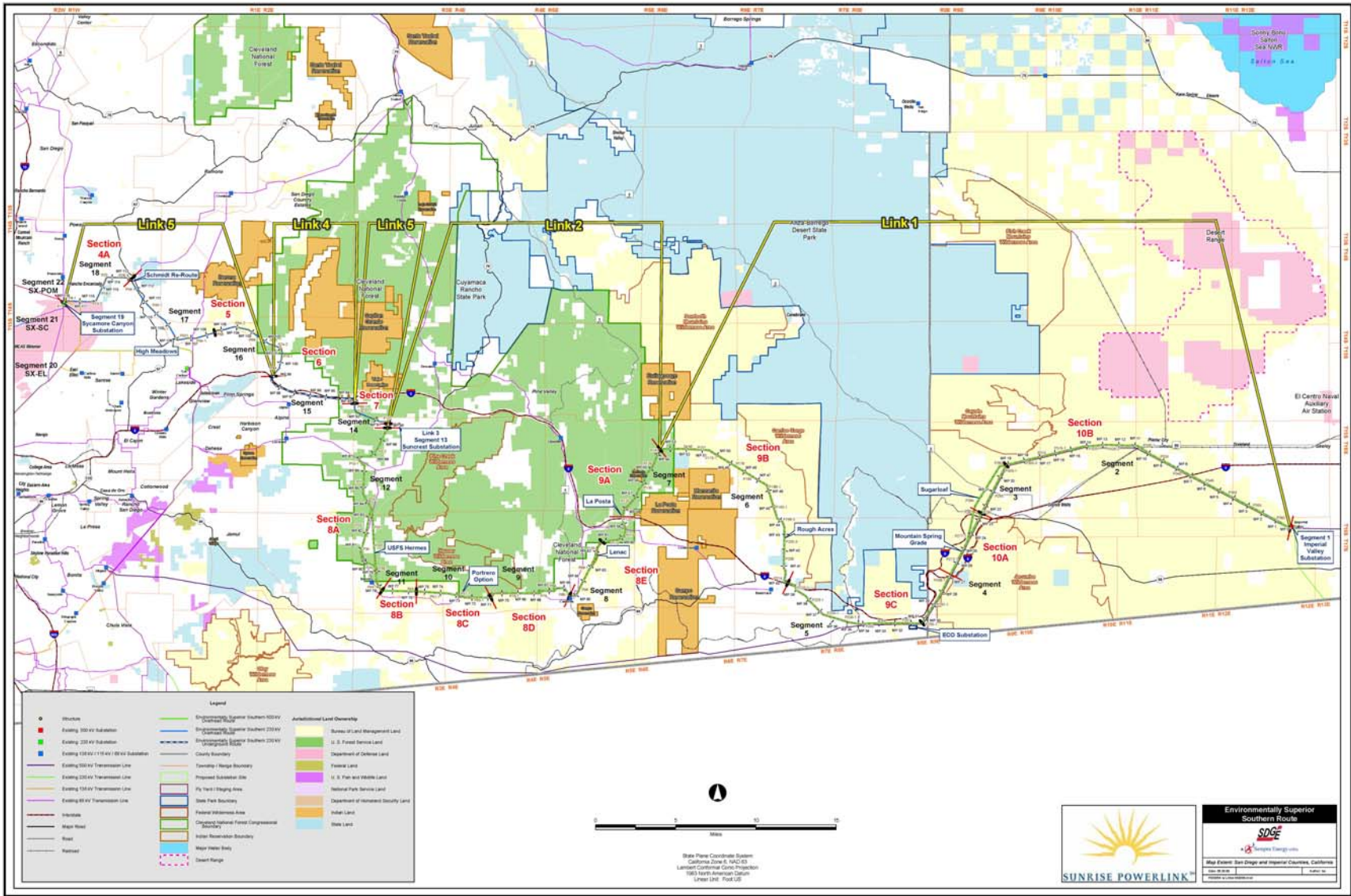

APPENDIX B  
Construction Yard Outdoor Lighting and Fixture Design



The light individual light sources will be oriented downward.





**Light Tower**
**LIGHT TOWER  
AL4000**

**Features**

- |  |  |
|--|--|
| <ul style="list-style-type: none"> <li>• Full sized, 30 ft (9.1 m) extended height floodlight tower illuminates 7-1/2 acres.</li> </ul>                | <ul style="list-style-type: none"> <li>• Plug-in ballasts are installed in galvanized steel boxes.</li> </ul>  |
| <ul style="list-style-type: none"> <li>• Galvanized tower is 360° rotatable for easy aiming from the ground.</li> </ul>                                | <ul style="list-style-type: none"> <li>• Light fixtures plug into weatherproof receptacle box with UL and CSA approved connectors.</li> </ul>                                      |
| <ul style="list-style-type: none"> <li>• Winch handle ergonomically positioned for easy raising and lowering. Winch drum is inside cabinet.</li> </ul> | <ul style="list-style-type: none"> <li>• Retractable power cord automatically recoils into protective sleeve to prevent damage when raising, lowering and moving tower.</li> </ul> |
| <ul style="list-style-type: none"> <li>• Light fixtures mount securely on mast for travel or can be left on crossarm.</li> </ul>                       | <ul style="list-style-type: none"> <li>• Control panel located inside cabinet, protected from the elements.</li> </ul>   |
| <ul style="list-style-type: none"> <li>• Pallet pockets and lifting eye make unit easier to load and unload.</li> </ul>                                |  |

# Light Tower AL4000

## Specifications

Lamps	Metal halide 4 x 1,000 W
Generator	Brushless 60 Hz, 6.0 kw
Engine	Kubota diesel 13.6 hp
Fuel capacity	30 gal (114 L)
Wheel size	15 in (38 cm)
Axel rating	3,500 lbs (1,558 kg)
Tongue weight travel position	147 lbs (67 kg)
Total weight no fuel	1,950 lbs (885 kg)

## Options and Accessories

Kubota diesel water-cooled, 13.6 hp/8.0 kW generator set
Perkins/CAT diesel water-cooled, 14.3 hp/6.0 kW generator set
50 hz, 7 kW generator Kubota engine
Auto-start/stop
50 gal (189 L) fuel capacity
Block heater
Combination ring/ball hitch
Ring hitch 2.5"
Tail light package
Electric trailer brakes
Hydraulic surge brakes (ring or ball hitch)
Electric 12 volt winch
12 Volt dome light with switch
Export racking/preparation
700 CCA battery
Fuel water separator with fuel line heater
Low temperature coolant mixture (-40 deg F)
Battery heater blanket
Roda Deaco air shutdown system

## Dimensions

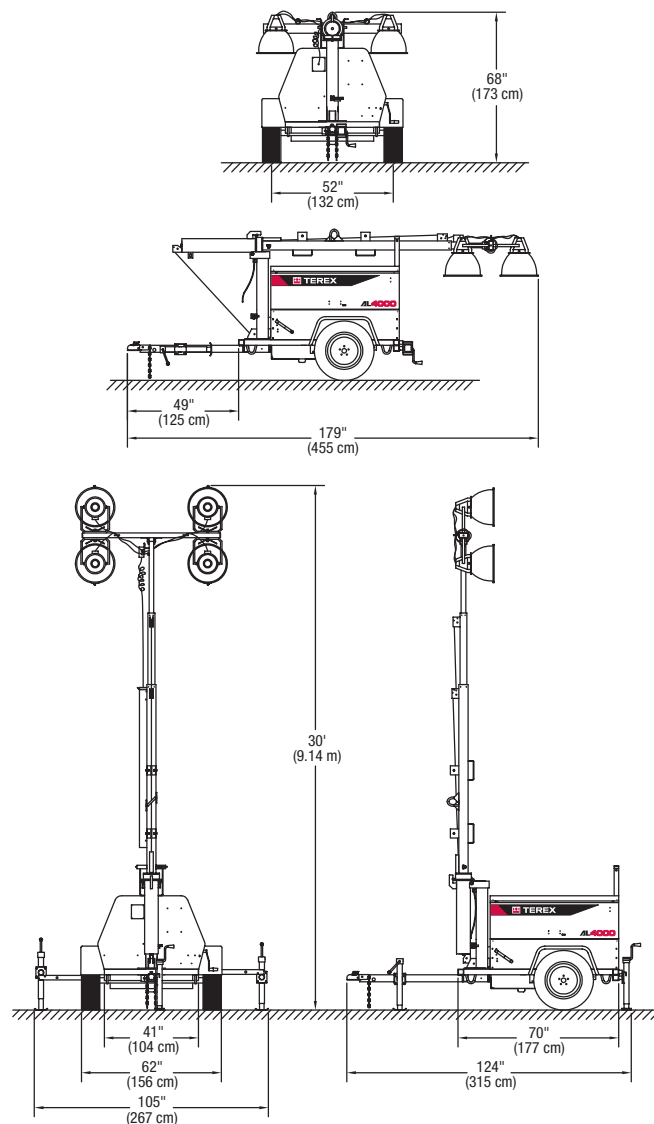

For more information, product demonstration, or details on purchase, lease and rental plans, please contact your local Genie distributor.



**Genie Industries, Inc.**  
A Terex Company

18340 NE 76th Street  
PO Box 97030  
Redmond, WA 98073-9730

TEL +1 (425) 881-1800  
TOLL FREE +1 (800) 536-1800  
PARTS & TECH SUPPORT +1 (800) 228-6444  
FAX +1 (425) 883-3475  
WEB [www.genieindustries.com](http://www.genieindustries.com)

Effective Date: January, 2010. Product specifications and prices are subject to change without notice or obligation. The photographs and/or drawings in this document are for illustrative purposes only. Refer to the appropriate Operator's Manual for instructions on the proper use of this equipment. Failure to follow the appropriate Operator's Manual when using our equipment or to otherwise act irresponsibly may result in serious injury or death. The only warranty applicable to our equipment is the standard written warranty applicable to the particular product and sale and we make no other warranty, express or implied. Products and services listed may be trademarks, service marks or trade-names of Terex Corporation, Genie Industries, Inc. and/or their subsidiaries in the U.S.A. and many other countries. All rights are reserved. Terex is a registered trademark of Terex Corporation in the U.S.A. and many other countries. Genie is a registered trademark of Genie Industries, Inc. in the U.S.A. and many other countries. Genie is a Terex Company. © 2010 Terex Corporation.



More saving. More doing.®

Welcome, (Sign In or Register) San Diego, CA is your

Share Email Print



Zoom View

### Husky Twin Head 1,200-Watt Halogen Work Light

Model # 553-143  
Store SKU # 553143

**\$44.97/EA-Each**

This item cannot be shipped to the following state(s): AK, HI

Average Customer Rating

★★★★☆ 3 out of 5

Write a review for a chance to win a \$1,000 Gift Card.

Read Reviews Write a Review

**\$44.97/EA-Each**  
Not Sold Online

Add to My List

Sold At Your Local Store

**SHOPPERS WHO VIEWED THIS ITEM ALSO VIEWED**



Centennial® 7.0 cu. ft. Super Capacity Electric Dryer...

**\$249.00/Each**



Centennial® 3.2 cu. ft. Super Capacity Top Load Washer...

**\$249.00/Each**

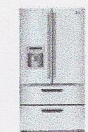

25.0 cu. ft. French Door Refrigerator: WAS \$2399

**\$1,198.00/Each**

**Description**

The convertible Husky Twin Head 1,200-Watt Halogen Work Light can be used on a portable sled base or attached to an adjustable 76 in. tripod. Each head of the light holds 2 halogen bulbs to provide up to 1,200 watts of light.

- 4 light levels allow fixture to be used up to 1,200 watts
- Fast tool-less bulb replacement
- No-knob ratcheting adjustment system
- Quick-release sled base detaches from tripod for portable use
- Heavy-duty grade construction for indoor or outdoor use
- Housing features a spare bulb storage tube
- Comes with five 300-watt bulbs
- Five 300 watt halogen bulbs included
- MFG Brand Name : Husky
- MFG Model # : 553-143
- MFG Part # : 553-143

**Specifications**

- Assembled Depth (in.) : 32 in
- Assembled Height (in.) : 76 in
- Assembled Width (in.) : 23 in
- Bulb Type : Halogen
- Cord Length : 7 ft
- Cord Length (ft.) : 7.0
- Electrical Product Type : Clamp/Handheld/Stand-up Work Light
- Grounded Receptacle : Yes
- Indoor/Outdoor : Indoor/Outdoor
- Item Package Type : Cardboard Container
- Item Weight : 19.5 lb
- Light Bulb Base Type : Double-Ended
- Manufacturer Warranty : Limited 3 year
- Maximum Bulb Wattage : 500 W
- Maximum Wattage : 1200 W
- Product Depth (in.) : 8.0
- Product Height (in.) : 76
- Product Weight (lb.) : 19.25
- Product Width (in.) : 23.0
- Type of Work Light : Tripod
- UL Listed : 1-UL Listed

**More Info**

**Warranty**

For warranty information on this product, please call our Internet Customer Service Center at 1-800-435-4654.

**Shipping**

# Actual Installation



## Monitored Security Tower

---

### Technical Specifications Division 28XXXX – Electronic Safety and Security

---

#### 2. PART 2 - PRODUCTS

##### 2.1. GENERAL

- 2.1.1. All systems and components shall have been thoroughly tested and proven in actual use in a minimum of one thousand installations.
- 2.1.2. All systems and components shall be provided with the availability of a toll-free 24-hour response program.
- 2.1.3. All equipment and components shall be standard components that are regularly utilized in the manufacturer's system.

##### 2.2. GENERAL SPECIFICATION

###### CamGuard Security Tower, patented device

- 2.2.1. The security tower shall consist of a base, a tower and device platform.
  - 2.2.1.1. Base shall be formed of structural concrete and weigh at least 2,500 pounds and be of sufficient strength to prevent tipping in 75 mph winds. The base shall contain a cavity of sufficient volume to house electronic equipment used to operate the security tower.
  - 2.2.1.2. The tower shall be steel and be at least twenty-five feet in height. It shall be substantially hollow and allow for wiring channels on the interior. The tower shall bolt security to the concrete base and form an integral unit.
  - 2.2.1.3. The tower shall be fitted with a device platform capable of mounting and supporting cameras, alarm devices, antennas, speakers or any other security device attendant to the operation of the security tower.

##### 2.3. EXTERNAL TOWER EQUIPMENT

- 2.3.1. Up to five fixed cameras shall be mounted on the security tower and shall be medium to high-resolution color devices fitted with 5 to 50 mm lenses.
- 2.3.2. A Pan-tilt-zoom (PTZ) camera may be mounted to the security tower and provides 359° of pan and 180° of tilt with up to a 35 times zoom lens. The PTZ shall be capable of preset action and alarm triggered action.
- 2.3.3. Communication equipment shall be mounted to the device to allow for communication on any standard wireless or wired network.
- 2.3.4. A minimum of one, 150-watt/350 peak speaker shall be mounted to the tower to allow voice-down communication.

## Monitored Security Tower

---

### Technical Specifications

#### Division 28XXXX – Electronic Safety and Security

---

- 2.3.5. Lighting devices shall be mounted to the tower and shall be either LED type, halogen or LPS type luminaires as required by the application.
- 2.3.6. Wireless alarm receiving equipment shall be mounted to the tower and allow for receipt of any standard alarm signal. The alarm receiving equipment shall receive the transmissions of wireless alarm devices which shall be deployed in sensor arrays around the tower in groups of sixteen and allow up to four groups to communicate alarm signals to the receiving equipment.
- 2.3.7. GPS, RFI, or access limiting equipment may be mounted to the tower and perform functions of people and/or equipment tracking and locating.
- 2.3.8. Thermal or other type imagers for measuring temperature deviations may be mounted to the tower.

#### 2.4. INTERNAL BASE EQUIPMENT

- 2.4.1. The base shall contain a digital video recorder (DVR) with up to sixteen looping channels of video, 16 alarm inputs, 8 relay outputs, two RS232 outputs, bidirectional audio, monitor output, and be capable of network and internet connections. The DVR shall allow remote video and alarm monitoring.
- 2.4.2. The base shall contain a router and communication device capable of sending high-speed video and alarm data over the internet or other communication system.
- 2.4.3. The base shall contain electrical equipment to facilitate power to cameras, lights and base electronics together with a UPS capable of continued operation after power outages.
- 2.4.4. The base shall contain sensors to signal when a power outage has occurred.

#### 2.5. OPERATING ELEMENTS

- 2.5.1. The security tower shall operate on standard 115 VAC/30 amp power.
- 2.5.2. The security tower shall contain adequate signage and postings to indicate its function and how to communicate with the manufacturer or monitoring company.

#### 2.6. PATENTS

- 2.6.1. The security tower shall be a patented device under the following patent numbers: US: 6,375,370; 6,709,171; 6,709,172; 6,585,428; 7,059,783-B1, 7,111,997-B2      Other Patents Pending

# PR

## Palomar LPS

LPS LUMINAIRES



- Formed and welded aluminum housing. Integral ballast mounted on rear door offers tool-free servicing. Secured with separable hinges and two trunk latches.
- Formed aluminum door with clear, flat or convex polycarbonate lens, fully gasketed to housing. Separable hinges and trunk latches provide tool-free entry.
- Specular, anodized aluminum, and prepainted white aluminum reflector combines to provide Type II, Short cutoff light pattern with flat lens; and Type III, Short Semi-cutoff light pattern with convex lens.
- Cast aluminum mast arm fitter for 2.375" OD horizontal arm, with set/leveling bolts, welded to housing.
- Lamp and lamp support device included. Enclosed socket, with nickel plated brass contact for single-ended, bayonet base LPS lamp.
- HR type ballast, HPF, starting rated at -20°F. Terminal block provided.
- Photo receptacle included less cell.
- Durable Lektrocote® TGIC thermoset polyester powder coat paint finish assures long life and maintenance-free service.
- UL1598 listed and CSA certified for outdoor use in wet locations.
- IESNA full cutoff classification when configured with flat lens.

### ORDERING INFORMATION

<b>PR</b>	-	<b>A</b>	-		-		-		-		-		-	
<b>SERIES</b>		<b>MOUNT</b>		<b>SOURCE/WATTAGE<sup>1</sup></b>		<b>LENS</b>		<b>COLOR</b>		<b>OPTIONS</b>				
PR Palomar - LPS		A Arm Mount		<b>LOW PRESSURE SODIUM</b> L35 35W (T-17) L55 55W (T-17) L90 90W (T-21) L13 135W (T-21) L18 180W (T-21)		F Flat C Convex		DB Dark Bronze BL Black WH White GR Gray PS Platinum Silver RD Red (premium color) FG Forest Green (premium color) CC Custom Color (consult factory)		F1 Fusing - 120V F2 Fusing - 208V F3 Fusing - 240V F4 Fusing - 277V F5 Fusing - 480V F6 Fusing - 347V				
						<b>LAMP ORIENT./DISTR.</b>								
						H2 Horiz. II (flat lens only) H3 Horiz. III (convex lens only)								
								<b>VOLTAGE</b>						
								Q Quad-Tap® 120/208/240/277V <sup>2</sup> T Tri-Tap 120/277/347V CSA <sup>2</sup> 5 480V						

<sup>1</sup> Lamps and lamp support devices included.  
<sup>2</sup> Factory wired for highest voltage unless specified.

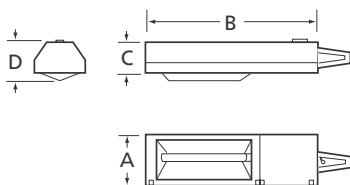

	A	B	C	D	EPA	Weight
<b>PR-LPS35</b>	9 1/2"	37"	5 1/2"	7"	1.2 ft <sup>2</sup>	30 lbs.
	241 mm	940 mm	140 mm	178 mm	0.1 m <sup>2</sup>	13.6 kg
<b>PR-LPS55</b>	9 1/2"	37"	5 1/2"	7"	1.2 ft <sup>2</sup>	30 lbs.
	241 mm	940 mm	140 mm	178 mm	0.1 m <sup>2</sup>	13.6 kg
<b>PR-LPS90</b>	9 1/2"	41"	5 1/2"	7"	1.4 ft <sup>2</sup>	32 lbs.
	241 mm	1042 mm	140 mm	178 mm	0.1 m <sup>2</sup>	14.5 kg
<b>PR-LPS135</b>	9 1/2"	51"	5 1/2"	7"	1.7 ft <sup>2</sup>	39 lbs.
	241 mm	1296 mm	140 mm	178 mm	0.2 m <sup>2</sup>	17.7 kg
<b>PR-LPS180</b>	9 1/2"	64"	5 1/2"	7"	2 ft <sup>2</sup>	44 lbs.
	241 mm	1626 mm	140 mm	178 mm	0.2 m <sup>2</sup>	19.9 kg

# PALOMAR-LPS SERIES

Cat. #	<b>PR A L90 H2 F Q BL</b>	Approvals
Job	Type	

**SPAULDING LIGHTING**

## APPLICATIONS

- Parking areas, office parks, schools, and walkways.

## SPECIFICATIONS

- Formed and welded aluminum housing. Integral ballast mounted on rear door offers tool-free servicing. Secured with separable hinges and two trunk latches.
- Formed aluminum door with clear, flat or convex polycarbonate lens, fully gasketed to housing. Separable hinges and trunk latches provide tool-free entry.
- Specular, anodized aluminum, and prepainted white aluminum reflector combines to provide Type II, Short cutoff light pattern with flat lens; and Type III, Short Semi-cutoff light pattern with convex lens.
- Cast aluminum mast arm fitter for 2.375" OD horizontal arm, with set/leveling bolts, welded to housing.
- Lamp and lamp support device included. Enclosed socket, with nickel plated brass contact for single-ended, bayonet base LPS lamp.
- HR type ballast, HPF, starting rated at -20°F. Terminal block provided.
- Photo receptacle included less cell.
- Durable Lektrocote® TGIC thermoset polyester powder coat paint finish assures long life and maintenance-free service.

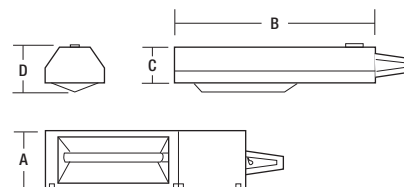

	A	B	C (arm)	D (arm)	EPA	Weight
<b>PR-LPS35</b>	9.5" 241 mm	37.0" 940 mm	5.5" 140 mm	7.0" 178 mm	1.2 ft. <sup>2</sup> 0.1 m <sup>2</sup>	30 lbs 13.6 kg
<b>PR-LPS55</b>	9.5" 241 mm	37.0" 940 mm	5.5" 140 mm	7.0" 178 mm	1.2 ft. <sup>2</sup> 0.1 m <sup>2</sup>	30 lbs 13.6 kg
<b>PR-LPS90</b>	9.5" 241 mm	41.0" 1042 mm	5.5" 140 mm	7.0" 178 mm	1.4 ft. <sup>2</sup> 0.1 m <sup>2</sup>	32 lbs 14.5 kg
<b>PR-LPS135</b>	9.5" 241 mm	51.0" 1296 mm	5.5" 140 mm	7.0" 178 mm	1.7 ft. <sup>2</sup> 0.2 m <sup>2</sup>	39 lbs 17.7 kg
<b>PR-LPS180</b>	9.5" 241 mm	64.0" 1626 mm	5.5" 140 mm	7.0" 178 mm	2.0 ft. <sup>2</sup> 0.2 m <sup>2</sup>	44 lbs 19.9 kg

## LISTINGS/CERTIFICATIONS

- UL1598 listed and CSA certified for outdoor use in wet locations.
- IDA fixture seal of approval when configured with flat lens.
- **IESNA full cutoff classification configured with flat lens.**



## ORDERING INFORMATION

### ORDERING EXAMPLE

<b>PR</b>	-	<b>A</b>	-	<b>L55</b>	-	<b>H2</b>	-	<b>F</b>	-	<b>Q</b>	-	<b>DB</b>	-	<b>F1</b>
Series		Mount		Wattage/ Source		Lamp Orientation/Distribution		Lens		Voltage		Color		Options

### SERIES

**PR** Palomar-LPS

### MOUNT

**A** Arm Mount

### WATTAGE/SOURCE<sup>1</sup>

#### LOW PRESSURE SODIUM

**L35** 35W (T-17)

**L55** 55W (T-17)

**L90** 90W (T-21)

**L13** 135W (T-21)

**L18** 180W (T-21)

### LAMP ORIENTATION/DISTRIBUTION

**H2** Horizontal II (flat lens only)

**H3** Horizontal III (convex lens only)

### LENS

**F** Flat

**C** Convex

### VOLTAGE

**Q** Quad-Tap® - 120/208/240/277V<sup>2</sup>

**T** Tri-Tap® - 120/277/347V CSA<sup>2</sup>

**5** 480V

### COLOR

**DB** Dark Bronze

**BL** Black

**WH** White

**GR** Gray

**PS** Platinum Silver

**RD** Red (premium color)

**FG** Forest Green (premium color)

**CC** Custom Color (consult factory)

### OPTIONS

**F1** Fusing - 120V

**F2** Fusing - 208V

**F3** Fusing - 240V

**F4** Fusing - 277V

**F5** Fusing - 480V

**F6** Fusing - 347V

<sup>1</sup> Lamps and lamp support devices included.

<sup>2</sup> Factory wired for highest voltage unless specified.

Due to our continued efforts to improve our products, product specifications are subject to change without notice.

**SPAULDING LIGHTING**

Spaulding Lighting • 701 Millennium Drive • Greenville, SC 29607 • PHONE: 864-678-1000

For more information visit our web site: [www.spauldinglighting.com](http://www.spauldinglighting.com)



APPENDIX C  
Night Construction Addendum

SDG&E and its contractors, may need to perform construction activities outside of the days/hours as established by the local jurisdiction. During times where SDG&E and its contractors may perform work, as approved by the local jurisdiction, outside of normal work hours, SDG&E will need to utilize lighting for the safety of personnel during construction activities.

SDG&E intends to perform these activities in Imperial County between structures EP290 and the existing Imperial Valley Substation, including the S2 Construction Yard, Plaster City Construction Yard, Dunaway Construction Yard, and the Imperial Valley Substation Construction Yard. SDG&E has coordinated with Imperial County to perform work outside of normal work hours and intends to establish an alternative schedule to avoid the summer heat. Coordination documentation with Imperial County is included with this variance request (Appendix D). During this time, construction lighting will be necessary while construction activities occur.

Work activities to be performed at night can include the following:

- Steel assembly and erection at the Project yards
- Steel assembly and erection at conventional tower sites (between structures EP290-EP363-1)
- Steel hauling and delivery to yards and right-of-way
- Rebar hauling and delivery to yards and right-of-way
- Rebar assembly and placement at conventional tower sites
- Stringing activities as required by CalTrans permits above Interstate 8

All other work activity types will be performed during normal project hours.

At the Construction Yards, Structure components will be received and crews can begin assembling the structure (tower). The tower steel components are delivered via flat-bed truck and trailer. The crews may utilize forklifts and smaller cranes (30-ton) to lift and place components together. Concrete reinforcing cages (rebar cages) may also be delivered and rebar cages may be assembled at the Project Yards. Crews may consist of 30 to 40 individuals and the appropriate monitors. Equipment on-site may be any combination of the following: Material delivery trucks, 4x4 Forklift, Crew hauling trucks, Water truck, Rough terrain crane, 50-foot bucket truck, Boom truck, Air compressor, Fuel Truck, Crew trucks.

At the Right-of-Way, structure components will be received and crews can begin assembling the structure (tower). The tower steel components are delivered to the

right-of-way via flat-bed truck and trailer. The crews may utilize forklifts and smaller cranes (30-ton) to lift and place components together. Rebar will also be delivered and rebar cages will be assembled at the tower locations. After assembly/erection, Quality Control inspections will be performed. Crews may consist of 6 to 10 individuals and the appropriate monitors. Equipment on-site may be any combination of the following: 4x4 Forklifts, Steel delivery trucks, Flat-bed Boom trucks, Flat-bed trucks and trailers, Backhoes, Small rough terrain hydraulic cranes (up to 150-ton), Crew trucks, Man Lifts 50-75', 4X4 Pick-ups & Utility trucks, Water truck, Power Tools (Gas and/or Pneumatic), Gas Powered 3-4kw Generator, Small Compressor.

Lighting will consist of the same light fixtures as previously identified in the approved Plan. SDG&E and its contractor will use portable light towers with integrated generators. The lighting source model will be a Terex Amida AL-4000, or comparable. Temporary construction light will be hooded, which will minimize backscatter to the nighttime sky, and allows the light to be pointed downward and away from sensitive receptors. It also allows the light to be localized to the area that the light is pointing towards. Lighting brightness will be limited to the minimum brightness needed for worker safety in construction activities and equipment operation. Lighting operation will be limited to the periods of activity at the site. Lighting will not be left on during periods of inactivity. All lighting is equipped with an "on-off" switch so light can be turned off when illumination is not necessary. At dawn, the lighting will be switched off by designated construction personnel, as lighting will no longer be necessary.

To reduce the potential for impacts to wildlife the following measures shall be implemented:

#### Training

- Prior to construction, SDG&E's contractors, subcontractors and Project personnel will receive training regarding the appropriate work practices necessary to effectively implement the mitigation measures (including implementation during night construction, when applicable) and comply with the applicable environmental laws and regulations (BIO-APM-2).

#### Lighting.

- All lighting will be of minimum necessary brightness consistent with worker safety (mitigation measure V-1b) and exterior lighting within the Project area adjacent to preserved habitat shall be of the lowest illumination necessary for human safety, selectively placed, shielded and directed away from preserved

habitat to the maximum extent practicable (mitigation measure BIO-APM-29 and general conservation measure G-CM-13).

- Lighting shall be designed so exterior fixtures are hooded per mitigation measure V-1b.
- Lighting will be directed downward or toward the area to be illuminated per mitigation measure V-1b.

### Travel

- Vehicle traffic associated with the project activities would be kept to a minimum volume and speed to prevent mortality of nocturnal wildlife species that may be moving about (mitigation measure BIO-APM-29).
- A 15 miles per hour speed limit shall be observed to prevent mortality of nocturnal wildlife species (mitigation measure BIO-APM-3 and general conservation measure G-CM-13).
- Monitoring shall be provided by a qualified biologist approved by the CPUC, BLM, and Wildlife Agencies to ensure that all impacts occur within designated limits. The qualified biologist shall conduct monitoring for any area subject to disturbance from construction (mitigation measure B-1c).
- Employees and contractors will look under vehicles and equipment for the presence of wildlife before movement. If wildlife is observed, no vehicles or equipment will be moved until the animal has left voluntarily or is removed by the qualified biologist (general conservation measure G-CM-40).

APPENDIX D  
Coordination Documentation



IMPERIAL COUNTY

# PLANNING & DEVELOPMENT SERVICES

PLANNING / BUILDING INSPECTION / ECONOMIC DEVELOPMENT / PLANNING COMMISSION / A.L.U.C.

**JURG HEUBERGER, AICP, CEP, CBO**  
PLANNING & DEVELOPMENT SERVICES DIRECTOR

October 20, 2010

Derek Dessert, Project Manager  
Development Design and Engineering, Inc.  
1065 West State Street  
El Centro, CA 90043

**SUBJECT: SDG&E Sunrise Power Link/ Noise levels**

Dear Mr. Dessert:

On October 6, 2010 the Imperial County Planning & Development Services Department met with your firm Development Design and Engineering. The meeting was a follow-up to the Department's September 17, 2010 letter to Development Design and Engineering, regarding the requested modification to hours of construction for your client SDG&E's Sunrise Power Link project.

In the Department's September 17, 2010 letter we stated that there was a limit to the hours of construction activity permitted. The Sunrise Power link Final EIR/EIS stated that construction activities were approved for 7:00 AM to 7:00 PM, Monday through Friday (no Saturdays). A provision in the Final EIR-EIS gave the County of Imperial (local jurisdiction) the authority to permit an alternative schedule. The Imperial County General Plan, Noise Element, the hours allowed for construction operations are Monday through Friday, 7:00 AM to 7:00 PM and Saturdays 9:00 AM to 5:00 PM.

The above time limitations strictly refer to the generation of noise that would exceed the normally actable noise levels within a given zone or type of use. Construction noise is classified separately from normally accepted noises. Under the County's General Plan the highest acceptable noise levels permitted in a given zone or type of use is 70 dB  $L_{eq}$  (or CNEL db). This level of noise is found in agricultural, industrial, commercial, utilities, and open space areas, while residential uses limit noise levels to 50 dB  $L_{eq}$ . Construction noise, which is considered temporary noise allows for the exceedance of the normally accepted noise to a maximum of 75 dB  $L_{eq}$ . The caveat is the limited hours and days that construction noise is permitted. Additionally, noise levels are measured at the property boundary or within in the interior of a structure.

The majority of the Imperial County leg of the Sunrise Power Link project is located on government open space land, where the acceptable noise level is 70 dB  $L_{eq}$ , which is only 5 dB  $L_{eq}$  lower than the maximum allowed construction noise.

Therefore provided the SDG&E, is contractor, subcontractors, etc... do not exceed the noise level of the specific zone they can work beyond the construction noise hours limitations. The Noise Element is available on the Department's website [www.icpds.com](http://www.icpds.com) which includes zoning and land uses along with their various noise levels.

If you have any questions, please do not hesitate to contact me at [jimminnick@co.imperial.ca.us](mailto:jimminnick@co.imperial.ca.us) or by telephone at 760-482-4236 extension 4278.

Sincerely,

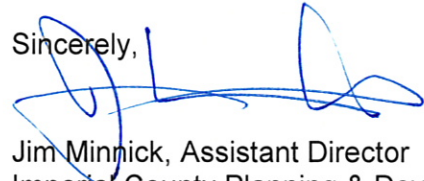

Jim Minnick, Assistant Director  
Imperial County Planning & Development Services Department

cc: Darrell Gardner, Interim Director  
Patricia Valenzuela, Planner III  
Daniel Stewart, BLM  
Files: 10.101, 10.102, SDGE