

SECTION
 500-kV Ductbank Installation
 Along USFS Access Road
 (3 Ductbanks Shown)

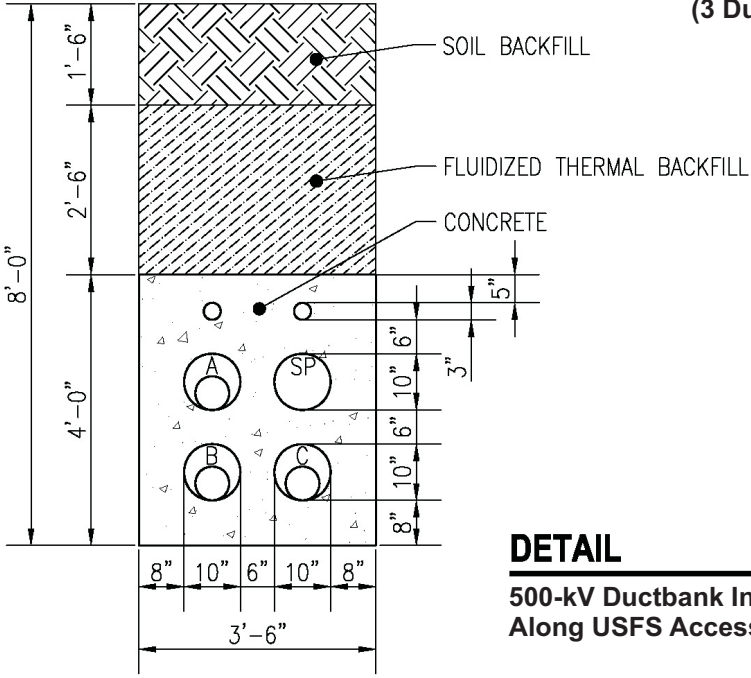

DETAIL
 500-kV Ductbank Installation
 Along USFS Access Road

Source: RW Beck, 2005



Figure B.4-4
 Underground Transmission Cross-section in the ANF