

Storm Water Pollution Prevention Plan (SWPPP)

**Encina Substation Upgrade
4600 Carlsbad Blvd.
Carlsbad, CA 92008**



July 23, 2010



**Prepared for:
SDG&E**

8315 Century Park Court
San Diego, CA 92123

**Prepared by:
Bureau Veritas**

11590 West Bernardo Court, Suite 100
San Diego, CA 92127
858.451.6100

www.us.bureauveritas.com

STORM WATER POLLUTION PREVENTION PLAN (SWPPP)

FOR

**SUNRISE POWERLINK
ENCINA SUBSTATION UPGRADE
LEVEL 1
CARLSBAD, CALIFORNIA 92008
San Diego Gas and Electric (SDG&E)**

Contract Number: 5660016733

This SWPPP has been prepared for **Traditional Projects** in accordance/compliance with the **State Water Resources Control Board** (SWRCB) Order No. 2009-0009-DWQ, National Pollutant Discharge Elimination System (NPDES) General Permit No. CAS000002 Waste Discharge Requirements for Discharges of Storm Water Runoff Associated with Construction and Land Disturbance Activities.

WDID #9 37C357876



A  Sempra Energy utility™

Prepared for:
SDG&E

8315 Century Park Court, CP21G
San Diego, CA 92123
(858)650-4064

Prepared by:

Bureau Veritas North America, Inc.
11590 W. Bernardo Court, Suite 100
San Diego, CA 92127
(858)451-6100

September 1, 2011

**This Document Must Be Returned to
AMETHYST CRUSPERO (858)650-4064 at Job Completion**

EMERGENCY CONTACT INFORMATION

Use the following contact numbers if there is an injury or other non-storm water related emergency occurs during the course the project:

SDG&E projects

Life threatening:	911
Non-life threatening:	(619) 725-5100 (Trouble Dispatch)

See Appendix XIII for the contact information for the Legally Responsible Person (LRP), Qualified SWPPP Developer (QSD), Qualified SWPPP Practitioner (QSP) and other parties responsible for the SWPPP implementation.

TABLE OF CONTENTS

EMERGENCY CONTACT INFORMATION	i
1.0 SWPPP CERTIFICATION.....	1
2.0 GENERAL INFORMATION	2
2.1 Background	2
2.2 Permit Registration Documents (PRDs).....	2
2.3 SWPPP Amendments.....	2
2.4 Availability of the SWPPP.....	3
2.5 Anticipated Non-Compliance Reporting	3
2.6 Certifications	3
2.7 Soil Contamination.....	3
2.8 Responsible Parties	4
3.0 PROJECT INFORMATION	5
3.1 OVERVIEW.....	5
3.2 PROJECT CHARACTERISTICS	5
3.2.1 Project Location	5
3.2.2 Project Description	5
3.2.3 Soil Disturbance and Total Area Estimate	6
3.2.4 Site Imperviousness	6
3.3 RECEIVING WATERS	6
3.4 WETLANDS.....	8
3.5 CONSTRUCTION, BMP IMPLEMENTATION AND MAINTENANCE SCHEDULES	9
3.6 SITE MAPS AND DIAGRAMS.....	9
4.0 RISK LEVEL 1 REQUIREMENTS	10
4.1 RISK DETERMINATION.....	10
4.2 GOOD SITE MANAGEMENT “HOUSEKEEPING”	10
A. Good Site Management (“Housekeeping”) Measures for Construction Materials	12
B. Good Site Management (“Housekeeping”) Measures for Waste Management	13
C. Good Site Management (“Housekeeping”) Measures for Vehicle Storage and Maintenance.....	16
D. Good Site Management (“Housekeeping”) Measures for Landscape Materials ..	17
E. Good Housekeeping for Assessment of Potential Pollutant Sources.....	18
F. Good Housekeeping for Control of Air Deposition	19
G. “Good Housekeeping” Documentation.....	20
4.3 NON-STORM WATER MANAGEMENT	21
4.4 EROSION CONTROL MEASURES.....	22
4.5 SEDIMENT CONTROL MEASURES.....	23
4.6 RUN-ON AND RUN-OFF CONTROLS	25
4.7 INSPECTION, MAINTENANCE AND REPAIR.....	26
4.8 RAIN EVENT ACTION PLAN (REAP).....	27
5.0 CONSTRUCTION SITE MONITORING PROGRAM (CSMP).....	28
6.0 RECORDKEEPING.....	29
6.1 ANNUAL REPORTS.....	30
7.0 TRAINING.....	31
8.0 EMERGENCY RESPONSE PLAN.....	32

APPENDICES

APPENDIX I – BLANK FORMS

Notice of Intent
PRDs Were Filed Record
Annual Reporting Form
Notice of Termination (NOT)
Post Construction BMP Type, Description, Location, and Inspection & Maintenance Requirements (if required)
SWPPP Amendment Log
Certification Form
Notification of Anticipated Non-Compliance Form
Training and Qualifications Forms
Site Inspection Forms
Visual Observation Form Non Stormwater Discharge
Visual Observation Form Qualifying Rain Event
REAP
QSP Implementation Checklist
Sampling Event Worksheet
NEL Violation Report
NAL Exceedance Report
History of Leaks and Spills
Secondary Containment and Spill Kit Inventory
Inventory of Potential Pollutant Sources Planned to be Used or Stored at the Project Site
List of Responsible Parties (Contact Information Form)
BMP Selection Worksheet

APPENDIX II – COPY OF CONSTRUCTION GENERAL PERMIT

(SWRCB) Order No. 2009 - 0009 – DWQ, NPDES General Permit No. CAS000002, WDRs for Discharges of Storm Water Runoff Associated with Construction and Land Disturbance Activities

APPENDIX III – SITE MAP (Retain in this appendix the current and all historic Site Maps)

Site map includes the following information:

- The project's surrounding area (vicinity)
- Site layout
- Construction site boundaries
- Drainage areas
- Discharge locations
- Sampling locations
- Areas of soil disturbance (temporary or permanent)
- Active areas of soil disturbance (cut or fill)
- Locations of all BMPs (original & revised)
- ATS location (if applicable)

- Locations of sensitive habitats, watercourses, or other features which are not to be disturbed
- Locations of all post-construction BMPs
- Locations of storage areas for waste, vehicles, service, loading/ unloading of materials, access (entrance/exits) points to construction site, fueling, and water storage, water transfer for dust control and compaction practices

APPENDIX IV – CALCULATIONS/ANALYSES

Risk Determination Analysis
Run-off Coefficient Calculations
Run-on Calculations
 Particle Size Analysis Results
Alternative Risk Analysis
Receiving Water Information, Including Applicable Water Quality Standards
Sediment Basin Sizing
Post-Construction Water Balance Calculator (see PRDs in Appendix XII)

APPENDIX V – CONSTRUCTION MATERIALS

Completed Inventory of Potential Pollutant Sources Planned to be Used or Stored at the Project Site*
List of Potential Pollutant Sources

APPENDIX VI – CONSTRUCTION BMP MANUAL

SDG&E Water Quality Construction Best Management Practices Manual
Other BMPs Cited in the SWPPP

APPENDIX VII – BMP INFORMATION

QSP Implementation Checklist *
BMP Selection Worksheet *
BMP Site Map
Final Landscaping and Site Stabilization BMPs - N/A
Post-Construction Water Balance Calculator - N/A

APPENDIX VIII – REAPS

APPENDIX IX – COMPLETED SITE INSPECTION FORMS

APPENDIX X – CONSTRUCTION SITE MONITORING PROGRAM (CSMP)

- 1 Overview
- 2 Visual Monitoring (Inspection) Requirements
 - 2.1 Exemptions for Visual Observation and Sample Collection
- 3 Water Quality Sampling and Analysis
- 4 Storm Water Discharge Water Quality Sampling Locations
- 5 Storm Water Sample Collection and Handling Instructions
- 6 Analytical and Monitoring Methods
- 7 NAL Exceedance Reports (Required for Risk Level 2 and 3 Projects) - N/A
- 8 NEL Violation Report (Required for Risk Level 3 Projects) - N/A
- 9 Compliance Storm Event Exemption
- 10 Watershed Monitoring Option (Required for Risk Level 2 and 3 Projects) - N/A
- 11 Particle Size Analysis for Project Risk Justification

APPENDIX XI – CSMP ATTACHMENTS

- A. Blank Forms
 - Visual Observation (Inspection) Form for Qualifying Rain Event *
 - Visual Observation (Inspection) Form for Non-Storm Water Discharge *
 - Sampling Event Worksheet *
- B. Observation (Inspection) Forms
 - Visual Observation (Inspection) Form for Qualifying Rain Event*
 - Visual Observation (Inspection) Form for Non-Storm Water Discharge*
- C. Reports
 - Internal NAL Non-Compliance Documentation (Numeric Action Level Report located in Appendix XVII of the SWPPP)
 - Internal NEL Non-Compliance Documentation (Numeric Effluent Limitation Report located in Appendix XVII of the SWPPP)
- D. Sampling and Analysis Results
 - Sampling Event Worksheet*
 - Field Meter Information
 - Calibration Records
 - Contact Information for Analytical Laboratory
 - Analytical Laboratory Results
- E. Sample Forms
 - Sample Chain of Custody Form
- F. RWQCB Correspondence: Additional Parameters for Storm Water Sampling
- G. Watershed Monitoring Option

APPENDIX XII –Permit Registration Documents (PRDS)

PRDs, including:

- PRDs Were Filed Record *
- Notice of Intent (NOI)
- Risk Assessment
- Site Map (original)
- SWPPP (electronic version, as submitted)
- Risk Assessment
- Post-Construction Water Balance Calculation
- ATS Design Document & Certification
- Approved Signatory Delegation (original), if applicable
- Annual Fee (copy of check)
- Signed Certification Statement

NOT, including:

- Application
- Receipt of Approval
- Waste Discharge Identification Number Letter

APPENDIX XIII – RESPONSIBLE PARTIES

List of Responsible Parties (Contact Information Form) *, including

- LRP
- QSD
- QSP
- Sampling personnel
- Inspection personnel
- Other SWPPP Implementation Personnel
- Non-Storm Water Management
- Project Contractors & Sub-Contractors List

APPENDIX XIV – INSPECTION CHECKLISTS

Spill/ Leak History Record

APPENDIX XV – TRAINING DOCUMENTATION

SWPPP Training, including*:

- Spill Response
- QSD
- QSP
- Personnel directed by QSP
- SWPPP Training and Qualifications Log

APPENDIX XVI – AMENDMENT LOG

Amendments Log*

APPENDIX XVII – REPORTS

- Annual Report *
- NEL Violation Report *
- NAL Exceedance Report *
- Anticipated Non-Compliance Reporting *
- Storm Water Reports
- Bioassessment Study Reports - N/A

APPENDIX XVIII – SECONDARY CONTAINMENT AND SPILL KIT INVENTORY

- Secondary Containment and Spill Kit Inventory *

APPENDIX XIX – OTHER SWPPP EXHIBITS

APPENDIX XX – ACTIVE TREATMENT SYSTEM (ATS)

- ATS Plan

APPENDIX XXI – BIOASSESSMENT – N/A

- Study Plan
- RWQCB approval for payment in lieu of field study
- Other documentation

APPENDIX XXII – Glossary/Acronyms

* - Indicates that a blank form is available in Appendix I

1.0 SWPPP CERTIFICATION

This SWPPP has been prepared for **Traditional Projects** in accordance/compliance with the **State Water Resources Control Board (SWRCB)** Order No. 2009-0009-DWQ, National Pollutant Discharge Elimination System (NPDES) General Permit No. CAS000002 Waste Discharge Requirements for Discharges of Storm Water Runoff Associated with Construction and Land Disturbance Activities.

Encina Substation Upgrade
4600 Carlsbad Boulevard,
Carlsbad, CA 92008.

"I certify under penalty of law that this document and all attachments were prepared under my direction or supervision in accordance with a system designed to assure that qualified personnel properly gather and evaluate the information submitted. Based on my inquiry of the person or persons who manage the system or those persons directly responsible for gathering the information, to the best of my knowledge and belief, the information submitted is true, accurate, and complete.

I am aware that there are significant penalties for submitting false information, including the possibility of fine and imprisonment for knowing violations."

Signed:

ROBERT C. JACKSON

Name of LRP *

General Manager & Director-Construction & Engineering Sunrise

Title

San Diego Gas & Electric

Company

(858) 654-6451

Telephone Number

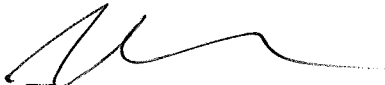
Signature

JULY 9, 2010

Date

*or approved signatory. The delegation of authority, for the Approved Signatory is included in Appendix XII.

I, Tracy Beach, am a Qualified Storm Water Pollution Prevention Plan (SWPPP) Developer and certify that I have completed this SWPPP for the **Encina Substation Upgrade** project and/or the amendments contained herein, in compliance with the **State Water Resources Control Board** (SWRCB) Order No. 2009-0009-DWQ, National Pollutant Discharge Elimination System (NPDES) General Permit No. CAS000002 Waste Discharge Requirements for Discharges of Storm Water Runoff Associated with Construction and Land Disturbance Activities.

Signature: TJBL

Print Name: Tracy Beach

Date: 2/22/10

Affix Certificate Number and/or Seal here:

Certificate Number C 73756

Seal:



I, Tracy Beach, certify that I am a Qualified Storm Water Pollution Prevention Plan (SWPPP) Developer. I have completed one or more of the following qualifying conditions (check all that apply):

- A California registered professional civil engineer;
- A California registered professional geologist or engineering geologist;
- A California registered landscape architect;
- A professional hydrologist registered through the American Institute of Hydrology;
- A Certified Professional in Erosion and Sediment Control (CPESC) TM registered through Enviro Cert International, Inc.;
- A Certified Professional in Storm Water Quality (CPSWQ) TM registered through Enviro Cert International, Inc.; or
- A professional in erosion and sediment control registered through the National Institute for Certification in Engineering Technologies (NICET).

Signature: Tracy Beach

Print Name: Tracy Beach

Date: 7/22/10

Affix Certificate Number and/or Seal here:

Certificate Number C 73756

Seal:



2.0 GENERAL INFORMATION

2.1 Background

This Storm Water Pollution Prevention Plan (SWPPP) was prepared for the Encina Substation Upgrade as a part of the overall Sunrise Powerlink Project (SPL), a linear construction project ("Project").

This SWPPP has been prepared in accordance with the State Water Resources Control Board (SWRCB) Order No. 2009-0009-DWQ, National Pollutant Discharge Elimination System (NPDES) General Permit No. CAS000002, Waste Discharge Requirements for Discharges of Storm Water Runoff Associated with Construction and Land Disturbance Activities (Construction General Permit) (hereto referred to as the CGP). The CGP became effective on July 1, 2010.

This SWPPP has been amended to comply with Order No. 2009-0009-DWQ [as amended by Order No. 2010-0014-DWQ] Section II.4.b Risk Determination requirements.

A copy of the CGP has been included in Appendix II of this SWPPP.

The goal of this SWPPP is to protect overall water quality during construction activities. Construction activities could potentially affect water quality by the storage and handling of various construction related materials as well as by causing soil erosion or sedimentation. With the implementation of the Best Management Practices (BMPs) and/or treatment outlined in this plan, the potential for the transport of contaminants or sediment to receiving waters will be minimized.

The SWPPP must be evaluated on an ongoing basis to document the changes and progression of construction activity throughout the life of the project.

2.2 Permit Registration Documents (PRDs)

The Permit Registration Documents (PRDs) and the State Water Resources Control Board's (SWRCB) confirmation of permit coverage (and Waste Discharge Identification Number) are contained in Appendix XII. Copies of PRD updates and annual fee checks are also contained in Appendix XII.

2.3 SWPPP Amendments

The Qualified SWPPP Developer (QSD) must prepare and certify each SWPPP amendment.

Blank forms of the SWPPP Amendment forms and Certification forms are located in Appendix I. Completed SWPPP Amendment forms are located in Appendix XVI.

2.4 Availability of the SWPPP

The SWPPP shall be available at the construction site during working hours while construction is occurring and shall be made available upon request by State or Municipal inspectors. When the original SWPPP is retained by a crewmember in a construction vehicle and is not currently at the construction site, current copies of the BMPs and exhibits will be left with the field crew and the original SWPPP shall be made available via a request by radio or telephone. Once construction activities are complete, until stabilization is achieved, the SWPPP shall be made available by the LRP.

2.5 Anticipated Non-Compliance Reporting

If there are any anticipated non-compliance events for the Encina Substation Upgrade project, a blank form (located in Appendix I) should be completed. Records of completed forms are retained in Appendix XVII.

This form must be submitted in advance of the planned change in construction activity that may result in non-compliance with the CGP to the Regional Water Board and local storm water management agency (see contact information in Appendix XIII).

2.6 Certifications

Certification requirements are described in Attachment A, Section D.9 and D.10 of the CGP.

2.7 Soil Contamination

If soil contamination is found, or suspected, and a responsible party is not identified, or the responsible party fails to promptly take the appropriate action, the LRP shall have those soils sampled and tested to ensure proper handling and public safety measures are implemented. Sampling and testing records shall be retained in Appendix XI. The LRP shall notify the appropriate local, state, and federal agency(ies) when contaminated soil is found at a construction site, and will notify the appropriate Regional Water Board.

LRP's shall ensure that trench spoils or any other soils disturbed during construction activities that are contaminated are not discharged with storm water or non-storm water discharges into any storm drain or water body except pursuant to an NPDES permit.

2.8 Responsible Parties

Implementation of the SWPPP involves a number of responsible parties including, but not limited to, the Legally Responsible Party (LRP), Approved Signatory, Qualified SWPPP Developer (QSD) and Qualified SWPPP Practitioner (QSP). Additionally, other persons may be specifically responsible for conducting inspections, sampling, and BMP installation under the direction of the QSP. These responsible parties are identified in Appendix XIII.

3.0 PROJECT INFORMATION

3.1 OVERVIEW

San Diego Gas & Electric (SDG&E) is dedicated to providing for the energy needs of its customers through the transmission and distribution of electric services. The need to upgrade existing facilities and to construct new facilities in support of new development is the primary impetus for SDG&E construction projects.

This SWPPP covers the Encina Substation Upgrade, a traditional construction project ("Project").

The goal of this SWPPP is to protect overall water quality during construction activities. Construction activities could potentially affect water quality by the storage and handling of various construction-related materials as well as by causing soil erosion or sedimentation. With the implementation of the Best Management Practices (BMPs) outlined in this plan, the potential for the transport of contaminants or sediment to receiving waters will be minimized.

3.2 PROJECT CHARACTERISTICS

3.2.1 Project Location

The Encina Substation Upgrade project is located at:	
ADDRESS	4600 Carlsbad Blvd.
CITY, STATE, ZIP CODE	Carlsbad, California 92008
THOMAS GUIDE LOCATION	San Diego County, page 1126, Section G-4
LATITUDE / LONGITUDE	33° 08'01.28" N 117°20'10.57" W

The project location is shown on the Site Map included in Appendix III.

3.2.2 Project Description

This SWPPP has been prepared for **Traditional Projects** in accordance/compliance with the **State Water Resources Control Board (SWRCB)** Order No. 2009-0009-DWQ, National Pollutant Discharge Elimination System (NPDES) General Permit No. CAS000002 Waste Discharge Requirements for Discharges of Storm Water Runoff Associated with Construction and Land Disturbance Activities (CGP) and the CGP identifies the following distinct phases of construction activities (listed below).

- Grading and Land Development Phase,
- Streets and Utilities Phase,
- Vertical Construction Phase,
- Final Landscaping and Site Stabilization and
- Inactive Construction Phase (i.e., 14 or more days of inactivity).

The upgrade plans for the new Encina Substation include installation of a 230/138 kV transformer to connect the two switchyards. The scope of work includes expanding the 230 kV switchyard and upgrading the 138 kV switchyard. Facilities in the 138 kV switchyard will be removed and relocated and the 230 kv switchyard will be expanded to accommodate the installation of a 230/138 kV, 392 MVA transformer. Excavations for foundations will take place within previously graded substation and will consist of concrete pads and piers. Trenching for control and power conduits and trenching for ground grid will take place entirely within the substation fencing at various locations within the previously graded site.

3.2.3 Soil Disturbance and Total Area Estimate

The initial estimated soil disturbance area for this Project is 3.3 acres.

Construction laydown/staging area, materials storage areas and employee and contractor parking areas will be located within the project area of the substation and are included in the disturbed acreage noted above.

Any changes to the initial estimate will be documented in the copies of the revised Notice of Intent documents submitted to the SWRCB (see Appendix XII).

3.2.4 Site Imperviousness

Approximately 85% of the pre-project site is impervious. Approximately 95% of the post-project site is impervious. Runoff coefficient calculations and run-on flow calculations are found in Appendix IV.

3.3 RECEIVING WATERS

This section identifies the receiving waters into which the project discharges and the conditions and specific requirements for this project.

Receiving Water Name: Agua Hedionda Lagoon and the Pacific Ocean

The Agua Hedionda Lagoon is located approximately .4 miles to the north of the Encina Substation Upgrade. Storm water will not discharge directly into this receiving water body. All storm water will be contained on site using a combination of construction and source control BMPs.

The Agua Hedionda Lagoon is listed on the SWRCB's 303(d) list.

- **Hydrologic Number(s)/Name(s):** 904.3 / Carlsbad Watershed
- **Surface Water Quality Objectives** applicable to this project's receiving waters are contained in Appendix IV.

- o **Specific information** for the **receiving waterbodies** listed above (Check all that apply):

Listed on SWRCB's 303(d) list for sedimentation, siltation or turbidity.

A Total Maximum Daily Load (TMDL) has been adopted that addresses this impairment.

Name of Waterbody / Impairment:

Agua Hedionda Lagoon – sedimentation siltation

A TMDL has not yet been adopted for this impairment.

Listed on SWRCB's 303(d) list for pollutants other than sedimentation, siltation or turbidity.

A TMDL has been adopted that addresses this impairment.

Name of Waterbody / Impairment:

Agua Hedionda Lagoon - bacteria

A TMDL has not yet been adopted for this impairment.

The 303(d) and/or TMDL requirements identified above are incorporated into the SWPPP site map/plans and other appropriate sections of the SWPPP.

- o **Specific information** for the **watersheds** down-gradient from the receiving water body (Check all that apply):

No surface waters are listed on the SWRCB's 303(d) list for sedimentation, siltation or turbidity.

A surface water body is listed on SWRCB's 303(d) list for sedimentation, siltation or turbidity.

Name of Waterbody / Impairment:

A TMDL has been adopted that addresses this impairment .

Name of Waterbody / Impairment:

A TMDL has not yet been adopted for this impairment.

No surface waters are listed on the SWRCB's 303(d) list for pollutants other than sedimentation, siltation or turbidity.

A surface water body is listed on SWRCB's 303(d) list for pollutants other than sedimentation, siltation or turbidity.

A TMDL has been adopted that addresses this impairment.

Name of Waterbody / Impairment:

A TMDL has not yet been adopted for this impairment.

3.4 WETLANDS

Projects that will cross or will conduct work within or immediately adjacent to waters of the US or state-only waters may require additional permits for these activities. Check all the boxes below that apply:

The project will cross or involve construction activities in a US Army Corps of Engineer's jurisdictional water body (e.g., wetland or waters of the United States).

Applicable federal & state permits have or will be obtained.

The project will cross or involve construction activities in a state-only jurisdictional water body (e.g., wetland or waters of the state, but not of the US).

Applicable state permits have or will be obtained.

3.5 CONSTRUCTION, BMP IMPLEMENTATION AND MAINTENANCE SCHEDULES

Estimated Date Construction will begin: *October 15, 2010*
Estimated Completion Date: *March 1, 2012*
Actual Start Date *TBD*

Applicable BMPs identified in this SWPPP are to be installed concurrently with the initiation of work and as work progresses at each location and will be routinely inspected and maintained.

No Final Landscaping and Site Stabilization BMPs will be installed for this project.

3.6 SITE MAPS AND DIAGRAMS

The Site Map is included in Appendix III.

The Site Map is included with the Permit Registration Documents (PRD's) in Appendix XII.

The Site Map shows:

- The project's surrounding area (vicinity);
- Site layout;
- Construction site boundaries;
- Locations of sensitive habitats, watercourses, or other features which are not to be disturbed;
- Areas of soil disturbance (temporary or permanent);
- Active areas of soil disturbance (cut or fill);
- Drainage areas;
- Discharge locations;
- Locations of all BMPs;
- ATS location (if applicable);
- Locations of storage areas for waste, vehicles, service, loading/unloading of materials, access (entrance/exits) points to construction site, fueling, and water storage, water transfer for dust control and compaction practices;
- Sampling location;
- Locations of all post-construction BMPs.

4.0 RISK LEVEL 1 REQUIREMENTS

4.1 RISK DETERMINATION

Risk Determinations have been completed and are contained in Appendix IV.

A. Effluent Standards

This project must meet narrative effluent standards. This project is a Risk Level 1 project; therefore numeric effluent standards are not applicable

4.2 GOOD SITE MANAGEMENT “HOUSEKEEPING”

The following sections describe specific measures to be implemented based on the risk level for this project. Tables have been provided for each measure described in the CGP Attachment C, D, or E that is applicable to the project’s risk level.

The first column of the table provides a measure identification number that corresponds to the applicable measure in the next column. The measures listed in the second column are required for Risk Level 1 projects.

The third column of the table describes whether this measure is applicable for the project.

The fourth column provides one or more BMP options that correspond to each required measure. These BMP Options(s) are references to the SDG&E Water Quality Construction Best Management Practices Manual (or “BMP Manual”).

The fifth column of the table identifies the location within the SWPPP that contains the information applicable to the fourth column. The information in the fourth column is either a BMP Option or an inventory form.

Locations of the applicable measures and BMP Options are identified on the Site Map located in Appendix III. The initial layout of the BMPs has been identified by the QSD as part of the preparation of the SWPPP. As site conditions change, it will be the responsibility of the QSD to make all revisions necessary.

The QSD prepared the tables below as part of the preparation of this SWPPP. It is the responsibility of the QSP to review these tables during the course of the project and advise the QSD to update the SWPPP as applicable. In addition, a QSP Implementation Checklist has been provided in Appendix VII to document the updates as applicable.

This section addresses good site management (i.e., "housekeeping") practices, including practices for:

- A. Construction Materials;
- B. Waste Management;
- C. Vehicle Storage and Maintenance;
- D. Landscape Materials;
- E. Assessment of Potential Pollutant Sources;
- F. Air Deposition; and
- G. Good Housekeeping Documentation

Tables have been provided for each good housekeeping measure described in the above sections, with the exception of Sections E and G. Sections E and G describe specific actions that must be taken to comply with the permit.

Each of the following measures is an element of Good Site Management "Housekeeping" as described in the CGP.

A. Good Site Management ("Housekeeping") Measures for Construction Materials at a minimum, shall consist of the following:

Construction Materials Measure ID No.	Construction Materials Measure	Applicable to Project?		BMP Option (check applicable option(s))	Location in SWPPP
		Yes	No		
CM-a	Conduct an inventory of the products used and/or expected to be used and the end products that are produced and/or expected to be produced.	X		QSP must conduct an inventory	Appendix V ¹
CM-b	Cover and berm loose stockpiled construction materials that are not actively being used (i.e. soil, spoils, aggregate, fly-ash, stucco, hydrated lime, etc.).	X		<input checked="" type="checkbox"/> BMP 1-08	Appendix VI
CM-c	Store chemicals in watertight containers (with appropriate secondary containment to prevent any spillage or leakage) or in a storage shed (completely enclosed).	X		<input checked="" type="checkbox"/> BMP 2-01 <input checked="" type="checkbox"/> BMP 2-02 <input checked="" type="checkbox"/> BMP 2-03 <input checked="" type="checkbox"/> BMP 2-04 <input checked="" type="checkbox"/> BMP 2-05 <input type="checkbox"/> BMP 2-06	Appendix VI
CM-d	Minimize exposure of construction materials with precipitation.	X		<input checked="" type="checkbox"/> BMP 2-01 <input checked="" type="checkbox"/> BMP 2-02 <input checked="" type="checkbox"/> BMP 2-03 <input checked="" type="checkbox"/> BMP 2-04 <input checked="" type="checkbox"/> BMP 2-05 <input type="checkbox"/> BMP 2-06 <input checked="" type="checkbox"/> BMP 2-07 <input type="checkbox"/> BMP 2-08	Appendix VI
CM-e	Implement BMPs to prevent the off-site tracking of loose construction and landscape materials.	X		<input checked="" type="checkbox"/> BMP 1-07	Appendix VI

¹ QSP to review List of Potential Pollutant Sources in Appendix V and complete an Inventory of Potential Pollutant Sources planned to be used or stored at the project site in Appendix V as well.

B. Good Site Management (“Housekeeping”) Measures for Waste Management at a minimum, shall consist of the following:

Waste Management Measure ID No.	Waste Management Measure	Applicable to Project?		BMP Option (check applicable option(s))	Location in SWPPP
		Yes	No		
WM-a	Prevent disposal of any rinse or wash waters or materials on impervious or pervious site surfaces or into the storm drain system.	X		<input checked="" type="checkbox"/> BMP 3-02 <input type="checkbox"/> BMP 3-03 <input type="checkbox"/> BMP 3-04 <input checked="" type="checkbox"/> BMP 3-05 <input type="checkbox"/> BMP 3-06 <input type="checkbox"/> BMP 3-07 <input type="checkbox"/> BMP 3-08 <input type="checkbox"/> BMP 3-09	Appendix VI
WM-b	Ensure the containment of sanitation facilities (e.g., portable toilets) to prevent discharges of pollutants to the storm water drainage system or receiving water.	X		<input checked="" type="checkbox"/> BMP 2-07	
WM-c	Clean or replace sanitation facilities and inspecting them regularly for leaks and spills.	X		<input checked="" type="checkbox"/> BMP 2-07	Appendix VI
WM-d	Cover waste disposal containers at the end of every business day and during a rain event.	X		<input checked="" type="checkbox"/> BMP 2-01 <input checked="" type="checkbox"/> BMP 2-02 <input checked="" type="checkbox"/> BMP 2-03 <input checked="" type="checkbox"/> BMP 2-04 <input checked="" type="checkbox"/> BMP 2-05 <input type="checkbox"/> BMP 2-06 <input checked="" type="checkbox"/> BMP 2-07 <input type="checkbox"/> BMP 2-08	Appendix VI
WM-e	Prevent discharges from waste disposal containers to the storm water drainage system or receiving water.	X		<input checked="" type="checkbox"/> BMP 2-01 <input checked="" type="checkbox"/> BMP 2-02 <input checked="" type="checkbox"/> BMP 2-03 <input checked="" type="checkbox"/> BMP 2-04 <input checked="" type="checkbox"/> BMP 2-05 <input type="checkbox"/> BMP 2-06 <input checked="" type="checkbox"/> BMP 2-07 <input type="checkbox"/> BMP 2-08	Appendix VI

B. Good Site Management (“Housekeeping”) Measures for Waste Management at a minimum, shall consist of the following:

Waste Management Measure ID No.	Waste Management Measure	Applicable to Project?		BMP Option (check applicable option(s))	Location in SWPPP
		Yes	No		
WM-f	Contain and securely protect stockpiled waste material from wind and rain at all times unless actively being used.	X		<input checked="" type="checkbox"/> BMP 1-08	Appendix VI
WM-g	Implement procedures that effectively address hazardous and non-hazardous spills.	X		<input checked="" type="checkbox"/> BMP 2-03	Appendix VI
WM-h	Develop a spill response and implementation element of the SWPPP prior to commencement of construction activities. The SWPPP shall require that: <ul style="list-style-type: none"> • Equipment and materials for cleanup of spills shall be available on site and that spills and leaks shall be cleaned up immediately and disposed of properly; and • Appropriate spill response personnel are assigned and trained. 	X		<input checked="" type="checkbox"/> BMP 2-03	-Appendix VI. -For spill response personnel, see Appendix XIII. -For relevant training see Appendix XV.
WM-i	Ensure the containment of concrete washout areas and other washout areas that may contain additional pollutants so there is no discharge into the underlying soil and onto the surrounding areas.	X		<input checked="" type="checkbox"/> BMP 2-04	Appendix VI

B. Good Site Management (“Housekeeping”) Measures for Waste Management at a minimum, shall consist of the following:

C. Good Site Management (“Housekeeping”) Measures for Vehicle Storage and Maintenance at a minimum, shall consist of the following:

Vehicle Storage and Maintenance Measure ID No.	Vehicle Storage and Maintenance Measure	Applicable to Project?		BMP Option (check applicable option(s))	Location in SWPPP
		Yes	No		
VSM-a	Prevent oil, grease, or fuel to leak in to the ground, storm drains or surface waters.	X		<input checked="" type="checkbox"/> BMP 3-03 <input checked="" type="checkbox"/> BMP 3-04 <input checked="" type="checkbox"/> BMP 3-05	Appendix VI
VSM-b	Place all equipment or vehicles, which are to be fueled, maintained and stored in a designated area fitted with appropriate BMPs.	X		<input checked="" type="checkbox"/> BMP 2-03 <input checked="" type="checkbox"/> BMP 2-02 <input type="checkbox"/> BMP 3-03 <input type="checkbox"/> BMP 3-04	Appendix VI
VSM-c	Clean leaks immediately and disposing of leaked materials properly.	X		<input checked="" type="checkbox"/> BMP 2-03	Appendix VI

D. Good Site Management (“Housekeeping”) Measures for Landscape Materials at a minimum, shall consist of the following:

Landscape Materials Measure ID No.	Landscape Materials Measure	Applicable to Project?		BMP Option (check applicable option(s))	Location in SWPPP
		Yes	No		
LM-a	Contain stockpiled materials such as mulches and topsoil when they are not actively being used.	X		<input checked="" type="checkbox"/> BMP 1-08 <input type="checkbox"/> BMP 4-07 <input type="checkbox"/> BMP 4-02	Appendix VI
LM-b	Contain fertilizers and other landscape materials when they are not actively being used.		X	<input type="checkbox"/> BMP 1-08 <input type="checkbox"/> BMP 2-01 <input type="checkbox"/> BMP 2-02	Appendix VI
LM-c	Discontinuing the application of any erodible landscape material within 2 days before a forecasted rain event ² or during periods of precipitation.		X	<input type="checkbox"/> BMP 3-07 <input type="checkbox"/> BMP 2-02	Appendix VI
LM-d	Apply erodible landscape material at quantities and application rates according to manufacture’s recommendations or based on written specifications by knowledgeable and experienced field personnel.		X	<input type="checkbox"/> BMP 3-07 <input type="checkbox"/> BMP 2-02	Appendix VI
LM-e	Stacking erodible landscape material on pallets and covering or storing such materials when not being used or applied.		X	<input type="checkbox"/> BMP 3-07 <input type="checkbox"/> BMP 2-01 <input type="checkbox"/> BMP 2-02	Appendix VI

² Excerpt from CGP – 50% or greater chance of producing precipitation.

E. Good Housekeeping for Assessment of Potential Pollutant Sources

Pollutant sources will be dynamic over the life of the construction project due to the various phases of construction.

An assessment of construction materials that may be used and activities that will be performed during this project that may have the potential to contribute pollutants, other than sediment, to storm water runoff for the project is located in Appendix V. The QSP must review the list throughout the life of the project and update it accordingly. Appropriate revisions to the SWPPP based on any changes to the list shall be made by the QSD.

In addition, a history of leaks or spills is maintained in Appendix XIV.

F. Good Housekeeping for Control of Air Deposition

This project shall implement good housekeeping measures on the construction site related to Air Deposition:

Air Deposition Measure ID No.	Air Deposition Measures	Applicable to Project?		BMP Option (check applicable option(s))	Location in SWPPP
		Yes	No		
AD-a	Control the air deposition of site materials and from site operations. Such particulates can include, but are not limited to, sediment, nutrients, trash, metals, bacteria, oil and grease and organics.	<input checked="" type="checkbox"/>	<input type="checkbox"/>	<input checked="" type="checkbox"/> BMP 4-08	Appendix VI

G. “Good Housekeeping” Documentation

The project is a Risk Level 1 project; therefore, Good Housekeeping Documentation is not applicable for this project.

During the development of this SWPPP, the QSD determined which good housekeeping BMPs were applicable to the project. However, these BMPs may vary over the course of the project due to the nature and phase of the construction project.

For ease of the QSP, a checklist form has been provided in Appendix VII that identifies good housekeeping measures. The QSP must complete the form prior to the beginning each phase of construction.

The QSP must document these BMPs on the Site Inspection form (blank forms located in Appendix I and completed forms to be located in Appendix IX)

4.3 NON-STORM WATER MANAGEMENT

All non-storm water discharges are required to be controlled. BMPs must be implemented for construction related activities that are potential sources of discharges other than storm water.

Implement the following measures to control all Non-Storm Water Discharges during construction:

Non-Storm Water Management Measure ID No.	Measure	Applicable to Project?		BMP Option (check applicable option(s))	Location in SWPPP
		Yes	No		
NSWM-a	Implement measures to control all non-storm water discharges during construction.	X		<input type="checkbox"/> BMP 3-03 <input checked="" type="checkbox"/> BMP 3-02 <input checked="" type="checkbox"/> BMP 1-07	Appendix VI
NSWM-b	Wash vehicles in such a manner as to prevent non-storm water discharges to surface waters or MS4 drainage systems.		X	<input type="checkbox"/> BMP 3-03	Appendix VI
NSWM-c	Clean streets in such a manner as to prevent non-storm water discharges from reaching surface water or MS4 drainage systems.	X		<input type="checkbox"/> BMP 3-02 <input checked="" type="checkbox"/> BMP 1-07	Appendix VI

Vehicles will not be washed on site.

4.4 EROSION CONTROL MEASURES

Erosion is the detachment of soil from existing landscapes by water or wind. Erosion is a natural process that can be accelerated by construction activities such as grading or trenching. For example, when a site is cleared or grubbed, protective vegetation is removed and the disturbed soil is directly exposed to wind and water. Erosion controls protect the surface and prevent the soil particles from being detached by rainfall or wind. BMPs for erosion control include soil stabilization.

Erosion Control measures, at a minimum, shall consist of the following:

Erosion Control Measure ID No.	Measures	Applicable to Project?		BMP Option (check applicable option(s))	Location in SWPPP
		Yes	No		
ECM-a	Implement effective wind erosion control.	X		<input checked="" type="checkbox"/> BMP 4-08	Appendix VI
ECM-b	Provide effective soil cover for inactive ³ areas and all finished slopes, open space, utility backfill, and completed lots.	X		<input checked="" type="checkbox"/> BMP 4-02 <input type="checkbox"/> BMP 4-03 <input type="checkbox"/> BMP 4-04 <input type="checkbox"/> BMP 4-05 <input type="checkbox"/> BMP 4-06 <input type="checkbox"/> BMP 4-07	Appendix VI
ECM-c	Limit the use of plastic materials when more sustainable, environmentally friendly alternatives exist. Where plastic materials are deemed necessary, the LRP shall consider the use of plastic materials resistant to solar degradation.	X		<input checked="" type="checkbox"/> BMP 4-07	Appendix VI

³ Inactive areas of construction are areas of construction activity that have been disturbed and are not scheduled to be re-disturbed for at least 14 days.

4.5 SEDIMENT CONTROL MEASURES

Sediment Control measures, at a minimum, shall consist of the following:

Sediment Measure ID No.	Measure	Applicable to Project?		BMP Option (check applicable option(s))	Location in SWPPP
		Yes	No		
SC-a	Establish and maintain effective perimeter controls and stabilize all construction entrances and exits to sufficiently control erosion and sediment discharges from the site.	X		<input checked="" type="checkbox"/> BMP 1-01 <input checked="" type="checkbox"/> BMP 1-02 <input checked="" type="checkbox"/> BMP 1-03 <input checked="" type="checkbox"/> BMP 1-04 <input type="checkbox"/> BMP 1-05 <input type="checkbox"/> BMP 1-06 <input checked="" type="checkbox"/> BMP 1-07 <input checked="" type="checkbox"/> BMP 1-08	Appendix VI
SC-b	On sites where sediment basins are to be used, at a minimum, design sediment basins according to the method provided in CASQA's Construction BMP Guidance Handbook		X	N/A	Appendix VI
SC-c	Implement appropriate erosion control BMPs (runoff control and soil stabilization) in conjunction with sediment control BMPs for areas under active ⁴ construction.	X		<input checked="" type="checkbox"/> BMP 4-02 <input type="checkbox"/> BMP 4-03 <input type="checkbox"/> BMP 4-04 <input type="checkbox"/> BMP 4-05 <input type="checkbox"/> BMP 4-06 <input type="checkbox"/> BMP 4-07	Appendix VI
SC-d	Apply linear sediment controls along the toe of the slope, face of the slope, and at the grade breaks of exposed slopes to comply with sheet flow lengths ⁵ in accordance with Table 1 (See Table 1 below).		X	<input type="checkbox"/> BMP 1-02 <input checked="" type="checkbox"/> BMP 1-03	Appendix VI
SC-e	Ensure that construction activity traffic to and from the project is limited to entrances and exits that employ effective controls to prevent offsite tracking of sediment.	X		<input checked="" type="checkbox"/> BMP 1-07	Appendix VI
SC-f	Ensure that all storm drain inlets and perimeter controls, runoff control BMPs, and pollutant controls at entrances and exits (e.g. tire washoff locations) are maintained and protected from activities that reduce their effectiveness.	X		<input checked="" type="checkbox"/> BMP 1-06	Appendix VI

⁴ Active areas of construction are areas undergoing land surface disturbance. This includes construction activity during the preliminary stage, mass grading stage, streets and utilities stage, and the vertical construction stage.

⁵ Sheet flow length is the length that shallow, low velocity flow travels across a site.

Sediment Measure ID No.	Measure	Applicable to Project?		BMP Option (check applicable option(s))	Location in SWPPP
		Yes	No		
SC-g	Inspect on a daily basis all immediate access roads daily. At a minimum daily (when necessary) and prior to any rain event, the LRP shall remove any sediment or other construction activity-related materials that are deposited on the roads (by vacuuming or sweeping).	X		<input checked="" type="checkbox"/> BMP 1-07	Appendix VI
SC-h	The Regional Water Quality Control Board (RWQCB) may require LRP's to implement additional site-specific sediment control requirements if the implementation of the other requirements in this section is not adequately protecting the receiving waters.	X		N/A	Appendix VI

Table 1 - Critical Slope/Sheet Flow Length Combinations (refer to ID No. SC-d)

Slope Percentage	Sheet flow length not to exceed
0-25%	20 feet
25-50%	15 feet
Over 50%	10 feet

4.6 RUN-ON AND RUN-OFF CONTROLS

Run-on and Run-off Controls shall be effectively managed for all run-on/run-off associated with the site and all runoff that discharges off the site, through the following measures:

Run-on and Run-off Control Measure ID No.	Measure	Applicable to Project?		Location in SWPPP
		Yes	No	
RRC-a	Effectively manage all run-on, all runoff within the site and all runoff that discharges off the site.	X		Appendix VI
RRC-b	Run-on from off-site shall be directed away from all disturbed areas or shall collectively be in compliance with the effluent limitation in the CGP.	X		Appendix VI

BMPs include fiber rolls to direct run-on away from the project site, fiber rolls along the perimeter of the site, and gravel bags and energy dissipaters at outflow points.

4.7 INSPECTION, MAINTENANCE AND REPAIR

Inspections shall be conducted by the QSP or a trained individual directed by a QSP.

For each inspection required, Risk Level 1 projects shall complete a Site Inspection Form, located in Appendix IX. Prior to conducting a site inspection, obtain weather information at the following website: <http://www.srh.noaa.gov/forecast> and attach the information to the Inspection Form.

Risk Level 1 projects shall perform weekly inspections and observations and at least once each 24 hour period during extended storm events, to identify and record BMPs that have failed, or that could fail to operate as intended.

Upon identifying failures or other shortcomings, as directed by the QSP, the project shall begin implementing repairs or design changes to BMPs within 72 hours of identification and complete the changes as soon as possible.

Project Specific Inspection Requirements:

The inspection forms shall remain onsite with the SWPPP and at a minimum shall include:

- a. Inspection date and date the inspection report was written.
- b. Weather information (rain gauge), including presence or absence of precipitation, estimate of beginning of qualifying storm event, duration of event, time elapsed since last storm, and approximate amount of rainfall in inches.
- c. Site information, including stage of construction, activities completed, and approximate area of the site exposed.
- d. A description of any BMPs evaluated and any deficiencies noted.
- e. If the construction site is safely accessible during inclement weather, list the observations of all BMPs: erosion controls, sediment controls, chemical and waste controls, and non-storm water controls. Otherwise, list the results of visual inspections at all relevant outfalls, discharge points, downstream locations and any projected maintenance activities.
- f. Report the presence of noticeable odors or of any visible sheen on the surface of any discharges.
- g. Any corrective actions required, including any necessary changes to the SWPPP and the associated implementation dates.
- h. Photographs taken during the inspection, if any. These photos should be representative of actual site conditions, and be time stamped (dated).
- i. Inspector's name, title, and signature.

Blank Inspection Forms are located in Appendix I. Completed Site Inspection Forms are retained in Appendix IX.

4.8 RAIN EVENT ACTION PLAN (REAP)

The Encina Substation Upgrade project is a Risk Level 1, therefore a REAP is not required.

5.0 CONSTRUCTION SITE MONITORING PROGRAM (CSMP)

The Construction Site Monitoring Program (CSMP) for this project is located in Appendix X of this SWPPP.

6.0 RECORDKEEPING

The LRP shall electronically submit all storm event sampling results to the State Water Board no later than 5 days (for field samples only) after the conclusion of the storm event. For electronic submittal instructions, refer to Section IV of the CGP.

Records of all storm water monitoring information and copies of all reports (including Annual Reports) shall be retained for a period of at least three years. If, after three years the RWQCB has not required the records to be retained for a longer period, these records shall be managed in accordance with the company's record retention policy. All records shall be retained on-site while construction is ongoing. These records include:

- The date, place, time of facility inspections, sampling, visual observation (inspections), and/or measurements, including precipitation;
- The individual(s) who performed the facility inspections, sampling, visual observation (inspections), and or measurements; for laboratory analysis, all sampling, sample preservation, and analyses must be conducted according to test procedures under 40 CFR Part 136. Field discharge samples shall be collected and analyzed according to the specifications of the manufacturer of the sampling devices employed;
- The date and approximate time of analyses;
- The individual(s) who performed the analyses;
- A summary of all analytical results from the last three years, the method detection limits and reporting units, and the analytical techniques or methods used, and the chain of custody forms;
- Rain gauge readings from visual observations (inspections);
- Quality assurance/quality control records and results;
- Non-storm water discharge inspections and visual observation (inspections) and storm water discharge visual observation records (see Sections I.3 and I.10 of the CGP);
- Visual observation and sample collection exception records (see Section I.6 of the CGP), including the corrective actions taken in response to the observations;
- The records of any corrective actions and follow-up activities that resulted from analytical results, visual observation (inspections), or inspections; and
- All field and/or analytical data.

All of these records can be found in Appendix XI in this SWPPP.

6.1 ANNUAL REPORTS

The Annual Report must be certified by the LRP. A blank certification form is located in Appendix I. Include the signed certification form with the Annual Report submittal. Records of Annual Reports are maintained in Appendix XVII of this SWPPP.

The LRP shall prepare and electronically submit an Annual Report no later than September 1 of each year.

Refer to the CGP Section XVI for all pertinent submittal requirements.

7.0 TRAINING

The LRP shall ensure that all persons responsible for implementing requirements of the CGP are appropriately trained in accordance with the requirements described in Section VII of the CGP.

The LRP shall provide documentation of all training for persons responsible for implementing the requirements of the CGP in the Annual Reports.

Storm water pollution prevention training should be provided regularly by the LRP. Topics can include, but are not limited to:

- spill prevention and response;
- inspections;
- annual reporting;
- locations and functions of sediment/erosion control devices;
- good housekeeping;
- sampling;
- fines and penalties; and
- material management practices.

Blank Training Logs can be found in Appendix I. Attendance records should be kept for each training session in Appendix XV. Training relevant for the QSD, QSP and individuals directed by the QSP are also located in Appendix XV.

8.0 EMERGENCY RESPONSE PLAN

EMERGENCY RESPONSE PLAN

1. BUSINESS NAME: San Diego Gas & Electric – Encina Substation Upgrade

2. BUSINESS SITE ADDRESS: 4600 Carlsbad Blvd., Carlsbad California

3. BUSINESS TELEPHONE: (858)603-6241 24-Hour: (619)725-5100

4. BRIEF DESCRIPTION OF PRODUCT MANUFACTURED AND/OR SERVICE PROVIDED:

Upgrades and modifications to the existing substation to include equipment and structures removal, new paved access roads, foundations and transformers.

5. EVACUATION PROCEDURES: Notify employees to evacuate by shouting.

Employees will meet at the substation entrance.

Emergency Coordinators will be available at the substation entrance to assist Emergency Responders.

6. NOTIFICATION PROCEDURES:

In the event of a release or threatened release of a hazardous material the following agencies are to be notified:

PHONE NUMBERS:

A. Local Emergency Response Agencies 911
Hazardous Materials Management Division (619) 338-2222 (911 after working hours)

B. State Office of Emergency Services (800) 852-7550 or (916) 427-4341

NAME OF PERSON(S) RESPONSIBLE FOR COMPLETING NOTIFICATIONS:

DESCRIBE NOTIFICATION PROCEDURES: Notify agencies and call SDG&E Trouble Department as needed.

7. EMERGENCY PROCEDURES: Main Concerns: Fire or Chemical Spill.

FIRE - Evacuate if Necessary. Employees will notify local fire department. If safe, employees will shut off power and attempt to control fire using fire extinguisher.

SMALL CHEMICAL SPILL - Spilled material will be identified, contained and cleaned up with appropriate materials by trained personnel.

LARGE CHEMICAL SPILLS - Employee will notify Emergency Coordinator. If safe, spill will be identified, contained and prevented from entering storm drains and sewer. Spilled material will be cleaned up by trained personnel such as SDG&E's Hazmat Team or appropriate clean up contractors.

NOTE: Disposal of hazardous waste generated from spill cleanup will be managed in compliance with Local, State and Federal regulations.

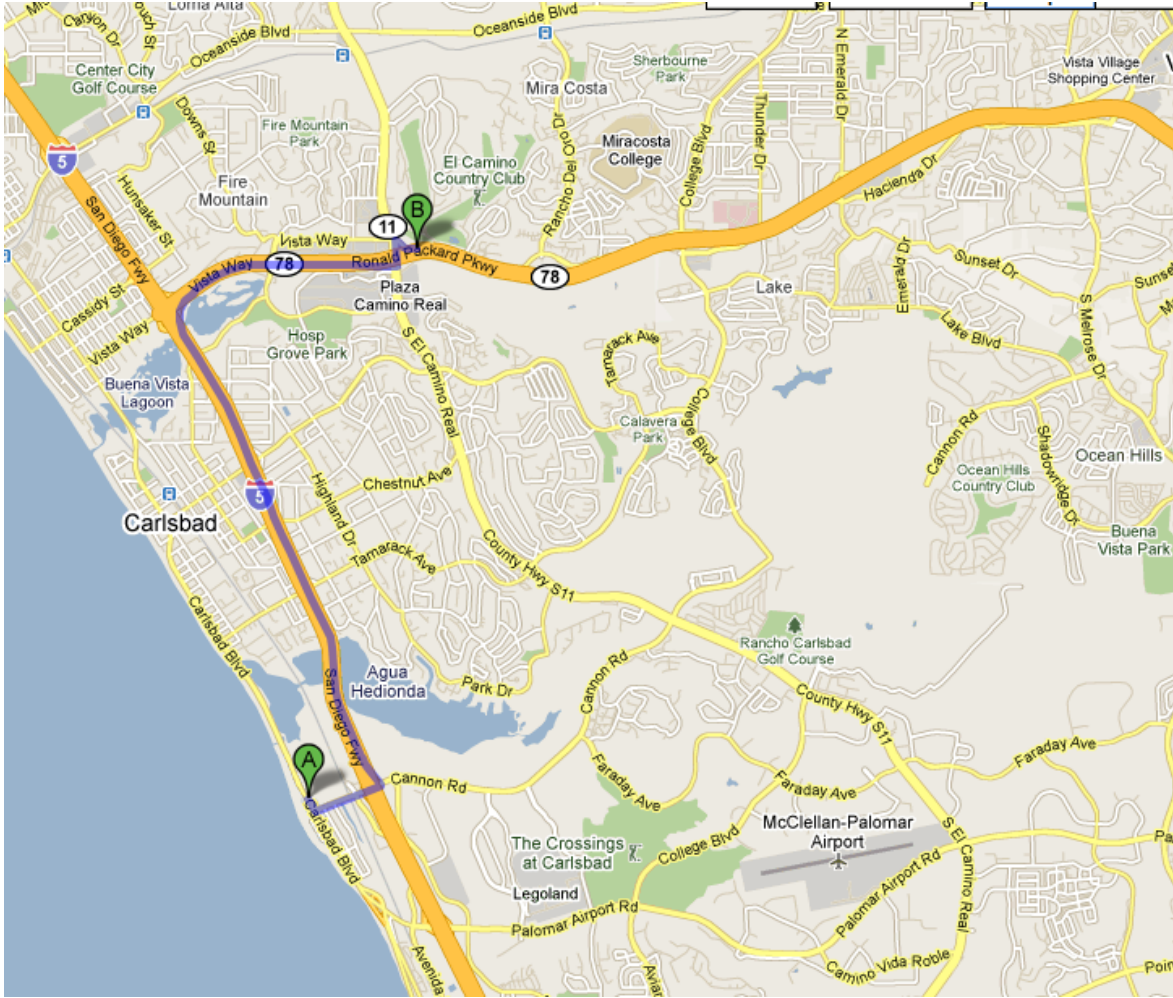

- A** 4600 Carlsbad Blvd
 Carlsbad, CA 92008
1. Head **southeast** on **Carlsbad Blvd** toward **Tierra Del Oro** 0.1 mi
 2. Take the **1st left** onto **Cannon Rd** 0.4 mi
 3. Turn **left** to merge onto **I-5 N** toward **Los Angeles** 3.1 mi
 4. Take exit **51B** to merge onto **CA-78 E** toward **Escondido** 1.3 mi
 5. Take the **El Camino Real** exit 0.3 mi
 6. Turn **left** at **S El Camino Real** 0.2 mi
 7. Take the **1st right** onto **Vista Way** 0.1 mi
 Destination will be on the left
- B** Tri-City Emergency Medical Group
 3156 Vista Way
 Oceanside, CA 92056-3622

Appendix I

Blank Forms



State Water Resources Control Board

NOTICE OF INTENT

TO COMPLY WITH THE TERMS OF THE
GENERAL PERMIT TO DISCHARGE STORM WATER
ASSOCIATED WITH CONSTRUCTION ACTIVITY (WQ ORDER No. 99-08-DWQ)



I. NOI STATUS (SEE INSTRUCTIONS)

MARK ONLY ONE ITEM	1. <input type="checkbox"/> New Construction	2. <input type="checkbox"/> Change of Information for WDID#	<input type="text"/>
--------------------	--	---	----------------------

II. PROPERTY OWNER

Name		Contact Person		
Mailing Address		Title		
City	State	Zip	Phone	
Owner Type (check one) 1. <input type="checkbox"/> Private Individual 2. <input type="checkbox"/> Business 3. <input type="checkbox"/> Municipal 4. <input type="checkbox"/> State 5. <input type="checkbox"/> Federal 6. <input type="checkbox"/> Other				

III. DEVELOPER/CONTRACTOR INFORMATION

Developer/Contractor		Contact Person		
Mailing Address		Title		
City	State	Zip	Phone	

IV. CONSTRUCTION PROJECT INFORMATION

Site/Project Name		Site Contact Person		
Physical Address/Location		Latitude _____°	Longitude _____°	County
City (or nearest City)		Zip	Site Phone Number	Emergency Phone Number
A. Total size of construction site area: _____ Acres	C. Percent of site imperviousness (including rooftops): Before Construction: _____%		D. Tract Number(s): _____, _____	
B. Total area to be disturbed: _____ Acres (% of total _____)	After Construction: _____%		E. Mile Post Marker: _____	
F. Is the construction site part of a larger common plan of development or sale? <input type="checkbox"/> YES <input type="checkbox"/> NO		G. Name of plan or development:		
H. Construction commencement date: ____/____/____		J. Projected construction dates: Complete grading: ____/____/____ Complete project: ____/____/____		
I. % of site to be mass graded: _____				
K. Type of Construction (Check all that apply): 1. <input type="checkbox"/> Residential 2. <input type="checkbox"/> Commercial 3. <input type="checkbox"/> Industrial 4. <input type="checkbox"/> Reconstruction 5. <input type="checkbox"/> Transportation 6. <input type="checkbox"/> Utility Description: _____ 7. <input type="checkbox"/> Other (Please List): _____				

V. BILLING INFORMATION

SEND BILL TO: <input type="checkbox"/> OWNER (as in II. above)	Name	Contact Person	
<input type="checkbox"/> DEVELOPER (as in III. above)	Mailing Address	Phone/Fax	
<input type="checkbox"/> OTHER (enter information at right)	City	State	Zip

VI. REGULATORY STATUS

A. Has a local agency approved a required erosion/sediment control plan?..... YES NO
Does the erosion/sediment control plan address construction activities such as infrastructure and structures?..... YES NO
Name of local agency: _____ Phone: _____

B. Is this project or any part thereof, subject to conditions imposed under a CWA Section 404 permit of 401 Water Quality Certification?..... YES No
If yes, provide details: _____

VII. RECEIVING WATER INFORMATION

A. Does the storm water runoff from the construction site discharge to (Check all that apply):
1. Indirectly to waters of the U.S.
2. Storm drain system - Enter owner's name: _____
3. Directly to waters of U.S. (e.g. , river, lake, creek, stream, bay, ocean, etc.)
B. Name of receiving water: (river, lake, creek, stream, bay, ocean): _____

VIII. IMPLEMENTATION OF NPDES PERMIT REQUIREMENTS

A. STORM WATER POLLUTION PREVENTION PLAN (SWPPP) (check one)
 A SWPPP has been prepared for this facility and is available for review: Date Prepared: ___/___/___ Date Amended: ___/___/___
 A SWPPP will be prepared and ready for review by (enter date): ___/___/___
 A tentative schedule has been included in the SWPPP for activities such as grading, street construction, home construction, etc.

B. MONITORING PROGRAM
 A monitoring and maintenance schedule has been developed that includes inspection of the construction BMPs before anticipated storm events and after actual storm events and is available for review.
If checked above: A qualified person has been assigned responsibility for pre-storm and post-storm BMP inspections to identify effectiveness and necessary repairs or design changes..... YES NO
Name: _____ Phone: _____

C. PERMIT COMPLIANCE RESPONSIBILITY
A qualified person has been assigned responsibility to ensure full compliance with the Permit, and to implement all elements of the Storm Water Pollution Prevention Plan including:
1. Preparing an annual compliance evaluation..... YES NO
Name: _____ Phone: _____
2. Eliminating all unauthorized discharges..... YES NO

IX. VICINITY MAP AND FEE (must show site location in relation to nearest named streets, intersections, etc.)

Have you included a vicinity map with this submittal? YES NO
Have you included payment of the annual fee with this submittal?..... YES NO

X. CERTIFICATIONS

"I certify under penalty of law that this document and all attachments were prepared under my direction and supervision in accordance with a system designed to assure that qualified personnel properly gather and evaluate the information submitted. Based on my inquiry of the person or persons who manage the system, or those persons directly responsible for gathering the information, the information submitted is, to the best of my knowledge and belief, true, accurate, and complete. I am aware that there are significant penalties for submitting false information, including the possibility of fine or imprisonment. In addition, I certify that I have read the entire General Permit, including all attachments, and agree to comply with and be bound by all of the provisions, requirements, and prohibitions of the permit, including the development and implementation of a Storm Water Pollution Prevention Plan and a Monitoring Program Plan will be complied with."
Printed Name: _____
Signature: _____ Date: _____
Title: _____

ORIGINAL - MAKE COPIES

**PRDs Filed
(Store Completed Forms in Appendix XII)**

PRDs were filed:

Copy of Submittal:

The following documents, except the Annual Fee which was mailed, were submitted electronically to the SWRCB:

- Notice of Intent (NOI) – Enclosed
- Risk Assessment – Enclosed
- Site Map – Enclosed
- Storm Water Pollution Prevention Plan – Enclosed
- Annual Fee – Enclosed
- Signed Certification Statement – Enclosed

ANNUAL REPORTING FORM (Store Completed Forms in Appendix XVII)

Project Name _____

WDID Number _____

- Electronically submit no later than September 1 of each year
- Keep a copy in Appendix XVII of the SWPPP. Retain an electronic or paper copy for a minimum of three years after the date that the Annual Report is filed; after three years, retain in accordance with the company's record retention policy.

This Annual Reporting Form is for the period of _____ to _____ and includes the following documents:

Training Information:
(See Appendix XV)

1. Documentation of all training for individuals responsible for all activities associated with compliance with this Construction General Permit (CGP);
2. Documentation of all training for individuals responsible for BMP installation, inspection, maintenance, and repair; and
3. Documentation of all training for individuals responsible for overseeing, revising, and amending the SWPPP.

Storm Water Monitoring Information:
(See Appendix XI)

1. A summary and evaluation of all sampling and analysis results, including original laboratory reports;
2. The analytical method(s), method reporting unit(s), and method detection limit(s) of each analytical parameter (analytical results that are less than the method detection limit shall be reported as "less than the method detection limit");
3. A summary of all corrective actions taken during the compliance year;
4. Identification of any compliance activities or corrective actions that were not implemented;
5. A summary of all violations of the Construction General Permit (CGP);
6. The names of individual(s) who performed the facility inspections, sampling, visual observation (inspections), and/or measurements;
7. The date, place, time of facility inspections, sampling, visual observation (inspections), and/or measurements, including precipitation (rain gauge); and
8. The visual observation and sample collection exception records and reports specified in Attachments C, D, and E of the CGP.

Refer to Section XVI of the CGP for additional information specific to the Annual Reporting Requirements.



Linda S. Adams
Secretary for
Environmental Protection

State Water Resources Control Board

Division of Water Quality

1001 I Street • Sacramento, California 95814 • (916) 341-5537
Mailing Address: P.O. Box 1977 • Sacramento, California • 95812-1977
FAX (916) 341-5543 • Internet Address: <http://www.waterboards.ca.gov/stormwtr/index.html>



Arnold Schwarzenegger
Governor

To: Storm Water Permit Holder

**RE: NOTICE OF TERMINATION OF COVERAGE UNDER THE GENERAL
CONSTRUCTION STORM WATER PERMIT (GENERAL PERMIT)**

In order for us to terminate your coverage under the General Permit, please complete and submit the enclosed Notice of Termination (NOT) your local Regional Water Quality Control Board (RWQCB). Refer to the last page of the NOT packet for RWQCB locations.

Submittal of a NOT does not guarantee termination and outstanding invoices are still valid. If your NOT is denied, you will be required to continue complying with the requirements of the General Permit and all outstanding invoice(s) are due. You will be notified of your NOT status by the RWQCB or State Water Resources Control Board. Approval of your Notice of Termination does not relieve you from paying any applicable outstanding invoices.

Should you have any questions regarding this matter, please contact your local RWQCB at the number listed on the back page of the NOT package, or the Storm Water Unit at (916) 341-5537.

Sincerely,

Storm Water Unit
Division of Water Quality

Enclosure

SEND TO YOUR LOCAL RWQCB FOR APPROVAL

State of California
State Water Resources Control Board

NOTICE OF TERMINATION

OF COVERAGE UNDER THE NPDES GENERAL PERMIT NO. CAS000002
FOR DISCHARGES OF STORM WATER
ASSOCIATED WITH CONSTRUCTION ACTIVITY

Submission of this Notice of Termination constitutes notice that the owner (and his/her agent) of the site identified on this form is no longer authorized to discharge storm water associated with construction activity by NPDES General Permit No. CAS000002.

I. WDID NO.

II. OWNER

COMPANY NAME _____ CONTACT PERSON _____
STREET ADDRESS _____ TITLE _____
CITY _____ STATE _____ ZIP _____ PHONE _____

III. CONSTRUCTION SITE INFORMATION

A. DEVELOPER NAME _____ CONTACT PERSON _____
STREET ADDRESS _____ TITLE _____
CITY _____ CA _____ ZIP _____ PHONE _____

B. SITE ADDRESS _____ COUNTY _____
CITY _____ CA _____ ZIP _____ PHONE _____

IV. BASIS OF TERMINATION

_____ 1. The construction project is complete and the following conditions have been met.
- All elements of the Storm Water Pollution Prevention Plan have been completed.
- Construction materials and waste have been disposed of properly.
- The site is in compliance with all local storm water management requirements.
- A post-construction storm water operation and management plan is in place.

Date of project completion ____/____/____

_____ 2. Construction activities have been suspended, either temporarily _____ or indefinitely _____ and the following conditions have been met.
- All elements of the Storm Water Pollution Prevention Plan have been completed.
- Construction materials and waste have been disposed of properly.
- All denuded areas and other areas of potential erosion are stabilized.
- An operation and maintenance plan for erosion and sediment control is in place.
- The site is in compliance with all local storm water management requirements.

SEND TO YOUR LOCAL RWQCB FOR APPROVAL

Date of suspension ____/____/____ Expected start up date ____/____/____

____ 3. Site can not discharge storm water to waters of the United States (check one).

____ All storm water is retained on site.

____ All storm water is discharged to evaporation or percolation ponds offsite.

____ 4. Discharge of storm water from the site is now subject to another NPDES general permit or an individual NPDES permit.

NPDES Permit No. _____ Date coverage began ____/____/____

____ 5. There is a new owner of the identified site. Date of owner transfer ____/____/____

Was the new owner notified of the General Permit requirements? YES ____ NO ____

NEW OWNER INFORMATION

COMPANY NAME _____ CONTACT PERSON _____

STREET ADDRESS _____ TITLE _____

CITY _____ STATE _____ ZIP _____ PHONE _____

V. EXPLANATION OF BASIS OF TERMINATION (Attach site photographs - see instructions).

VI. CERTIFICATION:

I certify under penalty of law that all storm water discharges associated with construction activity from the identified site that are authorized by NPDES General Permit No. CAS000002 have been eliminated or that I am no longer the owner of the site. I understand that by submitting this Notice of Termination, I am no longer authorized to discharge storm water associated with construction activity under the general permit, and that discharging pollutants in storm water associated with construction activity to waters of the United States is unlawful under the Clean Water Act where the discharge is not authorized by a NPDES permit. I also understand that the submittal of this Notice of Termination does not release an owner from liability for any violations of the general permit or the Clean Water Act.

PRINTED NAME _____ TITLE _____

SIGNATURE: _____ DATE ____/____/____

REGIONAL WATER BOARD USE ONLY

This Notice of Termination has been reviewed, and I recommend termination of coverage under the subject NPDES general permit.

Printed Name _____ Region No. _____

Signature _____ Date ____/____/____

NOT effective date:
Date: ____/____/____

**INSTRUCTIONS FOR COMPLETING
NOTICE OF TERMINATION
FOR CONSTRUCTION ACTIVITY**

Who May File

Dischargers who are presently covered under NPDES General Permit No. CAS000002 for discharge of storm water associated with construction activity may submit a Notice of Termination when they meet one of the following criteria.

1. The construction project has been completed and the following conditions have been met: all elements of the Stormwater Pollution Prevention Plan have been completed; construction materials and equipment maintenance waste have been disposed of properly; the site is in compliance with all local storm water management requirements including erosion/sediment control requirements and the appropriate use permits have been obtained; and a post-construction storm water operation and management plan is in place.
2. Construction activities have been suspended, either temporarily or indefinitely and the following conditions have been: all elements of the Stormwater Pollution Prevention Plan have been completed; construction materials and equipment maintenance waste have been disposed of properly; all denuded areas and other areas of potential erosion are stabilized; an operation and maintenance plan for erosion and sediment control is in place; and the site is in compliance with all local storm water management requirements including erosion/sediment control requirements.
The date construction activities were suspended, and the expected date construction activities will start up again should be provided.
3. Construction site can not discharge storm water to waters of the United States. Please indicate if all storm water is retained on site or if storm water is collected offsite.
4. Discharge of construction storm water from the site is now subject to another NPDES general permit or an individual NPDES permit. The general permit or individual permit NPDES number and date coverage began should be provided.
5. There is a new owner of the identified site. If ownership or operation of the facility has been transferred then the previous owner must submit a Notice of Termination and the new owner must submit a Notice of Intent for coverage under the general permit. The date of transfer and information on the new owner should be provided. Note that the previous owner may be liable for discharge from the site until the new owner files a Notice of Intent for coverage under the general permit.

Where to File

Submit the Notice of Termination to the Executive Officer of the Regional Water Quality Control Board responsible for the area in which the facility is located. See attached. Submittal of a NOT does not guarantee termination and outstanding invoices are still valid. If the Executive Officer, or his designated staff, agrees with the basis of termination, the Notice of Termination will be transmitted to the State Water Board for processing at which time it will be determined if any outstanding invoices are still valid. Approval of your Notice of Termination does not relieve you from paying any applicable outstanding invoices. If the Executive Officer, or his designated staff, does not agree with the basis of termination, the Notice of Termination will be returned. The Regional Water Board may also inspect your site prior to accepting the basis of termination.

LINE-BY-LINE INSTRUCTIONS

All necessary information must be provided on the form. Type or print in the appropriate areas only. Submit additional information, if necessary, on a separate sheet of paper.

SECTION I--WDID NO.

The WDID No. is a number assigned to each discharger covered under the General Permit. If you do not know your WDID No., please call the State Water Board or Regional Water Board and request it prior to submittal of the Notice of Termination.

SECTION II--OWNER

Enter the owner of the construction site's official or legal name (This should correspond with the name on the Notice of Intent submitted for the site), address of the owner, contact person, and contact person's title and telephone number.

SECTION III--CONSTRUCTION SITE INFORMATION

In Part A, enter the name of the developer (or general contractor), address, contact person, and contact person's title and telephone number. The contact person should be the construction site manager completely familiar with the construction site and charged with compliance and oversight of the general permit. This information should correspond with information on the Notice of Intent submitted for the site.

In Part B, enter the address, county, and telephone number (if any) of the construction site. Construction sites that do not have a street address must attach a legal description of the site.

SECTION IV--BASIS OF TERMINATION

Check the category which best defines the basis of your termination request. See the discussion of the criteria in the Who May File section of these instructions. Provide dates and other information requested. Use the space under Explanation of Basis of Termination heading.

SECTION V--EXPLANATION OF BASIS OF TERMINATION

Please explain the basis or reasons why you believe your construction site is not required to comply with the General Permit. To support your explanation, provide a site map and photograph of your site.

SECTION VI--CERTIFICATION

This section must be completed by the owner of the site.

The Notice of Termination must be signed by:

For a Corporation: a responsible corporate officer

For a Partnership or Sole Proprietorship: a general partner or the proprietor, respectively.

For a Municipality, State, or other Non-Federal Public Agency: either a principal executive officer or ranking elected official.

For a Federal Agency: either the chief or senior executive officer of the agency.

CALIFORNIA REGIONAL WATER QUALITY CONTROL BOARDS

NORTH COAST REGION (1)
 5550 Skylane Blvd, Ste. A
 Santa Rose, CA 95403
 (707) 576-2220 FAX: (707)523-0135
<http://www.waterboards.ca.gov/northcoast/>

SAN FRANCISCO BAY REGION (2)
 1515 Clay Street, Ste. 1400
 Oakland, CA 94612
 (510) 622-2300 FAX: (510) 622-2640
<http://www.waterboards.ca.gov/sanfranciscobay/>

CENTRAL COAST REGION (3)
 895 Aerovista Place, Ste 101
 San Luis Obispo, CA 93401
 (805) 549-3147 FAX: (805) 543-0397
<http://www.waterboards.ca.gov/centralcoast/>

LOS ANGELES REGION (4)
 320 W. 4th Street, Ste. 200
 Los Angeles, CA 90013
 (213) 576-6600 FAX: (213) 576-6640
<http://www.waterboards.ca.gov/losangeles/>

LAHONTAN REGION (6 SLT)
 2501 Lake Tahoe Blvd.
 South Lake Tahoe, CA 96150
 (530) 542-5400 FAX: (530) 544-2271
<http://www.waterboards.ca.gov/lahontan/>

VICTORVILLE OFFICE (6V)
 14440 Civic Drive, Ste. 200
 Victorville, CA 92392-2383
 (760) 241-6583 FAX: (760) 241-7308
<http://www.waterboards.ca.gov/lahontan/>

CENTRAL VALLEY REGION (5S)
 11020 Sun Center Dr., #200
 Rancho Cordova, CA 95670-6114
 (916) 464-3291 FAX: (916) 464-4645
<http://www.waterboards.ca.gov/centralvalley/>

FRESNO BRANCH OFFICE (5F)
 1685 E St.
 Fresno, CA 93706
 (559) 445-5116 FAX: (559) 445-5910
<http://www.waterboards.ca.gov/centralvalley/>

REDDING BRANCH OFFICE (5R)
 415 Knollcrest Drive, Ste. 100
 Redding, CA 96002
 (530) 224-4845 FAX: (530) 224-4857
<http://www.waterboards.ca.gov/centralvalley/>

COLORADO RIVER BASIN REGION (7)
 73-720 Fred Waring Dr., Ste. 100
 Palm Desert, CA 92260
 (760) 346-7491 FAX: (760) 341-6820
<http://www.waterboards.ca.gov/coloradoriver/>

SANTA ANA REGION (8)
 3737 Main Street, Ste. 500
 Riverside, CA 92501-3339
 Phone (951) 782-4130 FAX: (951) 781-6288
<http://www.waterboards.ca.gov/santaana/>

SAN DIEGO REGION (9)
 9174 Sky Park Court, Ste. 100
 San Diego, CA 92123-4340
 (858) 467-2952 FAX: (858) 571-6972
<http://www.waterboards.ca.gov/sandiego/>

STATE OF CALIFORNIA
 Arnold Schwarzenegger, Governor

**CALIFORNIA ENVIRONMENTAL
 PROTECTION AGENCY**
 Linda S. Adams, Secretary

**STATE WATER RESOURCES
 CONTROL BOARD**
 Tam M. Doduc Chair

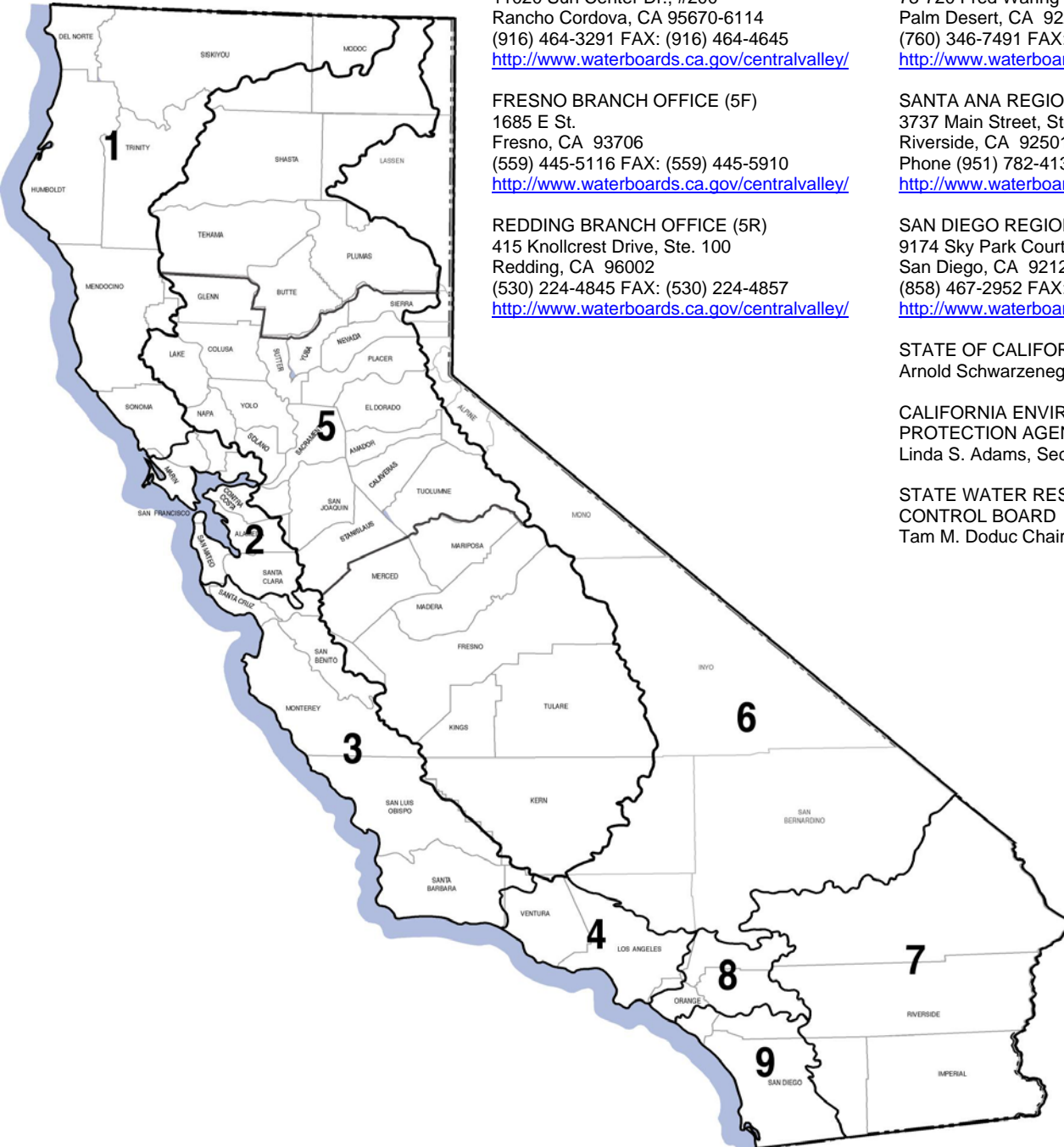

ORIGINAL - MAKE COPIES

**SWPPP Amendment Log
(Store Completed Forms in Appendix XVI)**

DATE:	BY:	DESCRIPTION:

ORIGINAL - MAKE COPIES

CERTIFICATION FORM (Store Completed Forms in Appendix XII)

Project Name _____

WDID Number _____

This certification is for (check appropriate box):

The QSD will complete this box and, once signed by the approved signatory, insert the signed certification form in the appropriate Appendix.

- Amendment to SWPPP (Appendix XVI)
- PRDs (Appendix XII)
- NOT (Appendix XII)
- Annual Report (Appendix XVII)
- Other _____

Any person signing documents under Section IV.1 of the CGP shall make the following certification:

"I certify under penalty of law that this document and all attachments were prepared under my direction or supervision in accordance with a system designed to assure that qualified personnel properly gather and evaluate the information submitted. Based on my inquiry of the person or persons who manage the system or those persons directly responsible for gathering the information, to the best of my knowledge and belief, the information submitted is, true, accurate, and complete. I am aware that there are significant penalties for submitting false information, including the possibility of fine and imprisonment for knowing violations."

Name of LRP *

Title

Company

Telephone Number

Signature

Date

*or approved signatory.

ORIGINAL - MAKE COPIES

NOTIFICATION OF ANTICIPATED NON-COMPLIANCE (Store Completed Forms in Appendix XVII)

This form will be used to report instances of anticipated non-compliance. The LRP must provide advanced notice to the local Regional Water Quality Control Board and local Storm Water Management Agency (see Appendix XIII for the relevant contact information).

Project Name _____

WDID Number _____

in accordance/compliance with the **State Water Resources Control Board** (SWRCB) Order No. 2009-0009-DWQ, National Pollutant Discharge Elimination System (NPDES) General Permit No. CAS000002 Waste Discharge Requirements for Discharges of Storm Water Runoff Associated with Construction and Land Disturbance Activities, the following discharge is anticipated:

Nature of planned change in construction activity that may result in non-compliance with CGP requirements:

Date, time, and location of anticipated discharge:

Name of LRP *

Title

Company

Telephone Number

Signature

Date

**or approved signatory.*

ORIGINAL - MAKE COPIES

**SWPPP Training and Qualifications Log
(Store Completed Form in Appendix XV)**

Project Name _____

WDID Number _____

Training Location: _____

Trainer(s): _____ **Date:** _____

TRAINING TOPICS COVERED

- Review and Discussion of SWPPP
- General BMPs for Site and Materials Management
- BMPs for Erosion and Sediment Control
- Spill or Release Response
- Proper Selection of BMPs
- Proper BMP Implementation/Maintenance Techniques
- Review and Discussion of SWPPP Inspection Requirements
- Review and Discussion of Sampling Requirements
- Sampling and Monitoring
- Record Keeping
- Other: _____

NAME	AREA OF RESPONSIBILITY	COMPANY NAME	PHONE NUMBER

ORIGINAL - MAKE COPIES

NAME	AREA OF RESPONSIBILITY	COMPANY NAME	PHONE NUMBER

Qualified SWPPP Developer (QSD) Qualifications

The Qualified SWPPP Developer (QSD) holds the following registration(s) and/or certification(s):

(Check all that apply and include a copy of the registration(s) and/or certification(s)):

- A California registered professional civil engineer;
- A California registered professional geologist or engineering geologist;
- A California registered landscape architect;
- A professional hydrologist registered through the American Institute of Hydrology;
- A Certified Professional in Erosion and Sediment Control (SPESC)TM registered through Enviro Cert, International, Inc.;
- A Certified Professional in Storm Water Quality (CPSWQ)TM registered through Enviro Cert, International, Inc.; or
- A professional in erosion and sediment control registered through the National Institute for Certification in Engineering Technologies (NICET).

-- AND --

The QSD attended formal State Water Board sponsored or approved QSD training course on the following date *:

Date: _____

Name of Course: _____

Presented by: _____

A copy of the certification of attendance is attached.

* A requirement as of September 2, 2011

Qualified SWPPP Practitioner (QSP) Qualifications

The Qualified SWPPP Practitioner (QSP)* holds the following registration(s) and/or certification(s):

Check all that apply and include a copy of the registration(s) and/or certification(s):

- Qualified SWPPP Developer (QSD)
- A certified erosion, sediment and storm water inspector registered through Enviro Cert, International, Inc.; or
- A certified inspector of sediment and erosion control registered through Certified Inspector of Sediment and Erosion Control, Inc.

* A requirement as of September 2, 2011, the QSP shall be either a QSD or have one of the above certifications:

-- AND --

The QSP attended formal State Water Board sponsored or approved QSP training course on the following date **:

Date: _____

Name of Course: _____

Presented by: _____

A copy of the certification of attendance is attached.

** A requirement as of September 2, 2011

ORIGINAL - MAKE COPIES

Inspection Form (Store Completed Form in Appendix IX)

Project Name	
WDID Number	
Date of Inspection	
Date Inspection Report was Written	
Name of QSP*	
Inspector's Company/Title	
Inspector's Signature	
Inspection Type	<input type="checkbox"/> Weekly <input type="checkbox"/> 24 Hour Interval During Extended Storm Events
	Date storm began: Duration of Storm :
	Rainfall Amount (inches): Precipitation: <input type="checkbox"/> Present <input type="checkbox"/> Absent
	Time elapsed since last storm (hours or days) _____

*Or individual conducting the inspection that has been trained by the QSP (herein referred to as Inspector).

Is the site safely accessible during inclement weather?

YES NO

If yes, list the observations of all BMPs: erosion controls, sediment controls, chemical and waste controls, and non-storm water controls.

If no, list why not safely accessible.

List the results of visual inspections at all relevant outfalls, discharge points, downstream locations and any projected maintenance activities.

A site map is attached that supplements this inspection form

YES NO

BMP No.	BMP Options (Additional BMPs shall be implemented as necessary to protect water quality as determined by field conditions)	Selected BMPs
BMP-1-02	Silt Fence	<input type="checkbox"/>
BMP-1-03	Fiber Rolls	<input type="checkbox"/>
BMP-1-04	Gravel Bag Berm	<input type="checkbox"/>
BMP-1-05	Sand Bag Barrier	<input type="checkbox"/>
BMP-1-06	Storm Drain Inlet Protection	<input type="checkbox"/>
BMP-1-07	Tracking Controls	<input type="checkbox"/>
BMP-1-08	Stockpile Management	<input type="checkbox"/>
BMP-2-01	Material Delivery and Storage	<input type="checkbox"/>
BMP-2-02	Material Use	<input type="checkbox"/>
BMP-2-03	Spill Control	<input type="checkbox"/>
BMP-2-04	Solid Waste Management	<input type="checkbox"/>
BMP-2-05	Hazardous Materials/Waste Management	<input type="checkbox"/>
BMP-2-06	Contaminated Soil Management	<input type="checkbox"/>
BMP-2-07	Sanitary/Septic Waste Management	<input type="checkbox"/>
BMP-2-08	Liquid Waste Management	<input type="checkbox"/>
BMP-3-01	Dewatering Operations	<input type="checkbox"/>
BMP-3-02	Paving Operations	<input type="checkbox"/>
BMP-3-03	Vehicle and Equipment Washing	<input type="checkbox"/>
BMP-3-04	Vehicle and Equipment Fueling	<input type="checkbox"/>
BMP-3-05	Concrete/Coring/Saw Cutting and Drilling Waste Management	<input type="checkbox"/>
BMP-3-06	Dewatering Utility Substructures and Vaults	<input type="checkbox"/>
BMP-3-07	Vegetation Management including Mechanical and Chemical Weed Control	<input type="checkbox"/>
BMP-3-08	Over-Water Protection	<input type="checkbox"/>
BMP-3-09	Removal of Utility Location/Mark-Out Paint	<input type="checkbox"/>
BMP-4-01	Preservation of Existing Vegetation	<input type="checkbox"/>
BMP-4-02	Temporary Soil Stabilization	<input type="checkbox"/>
BMP-4-03	Hydraulic Mulch	<input type="checkbox"/>
BMP-4-04	Hydroseeding	<input type="checkbox"/>
BMP-4-05	Soil Binders	<input type="checkbox"/>
BMP-4-06	Straw Mulch	<input type="checkbox"/>
BMP-4-07	Geotextiles, Plastic Covers and Erosion Control Blankets/Mats	<input type="checkbox"/>
BMP-4-08	Dust (Wind Erosion) Control	<input type="checkbox"/>
CASQA EC-10	Velocity Dissipation Devices	<input type="checkbox"/>
CASQA EC-12	Streambank Stabilization	<input type="checkbox"/>
CASQA NS-4	Temporary Stream Crossing	<input type="checkbox"/>
CASQA NS-5	Clear Water Diversion	<input type="checkbox"/>

Site Information		
Current stage of construction (check which applies)	<input type="checkbox"/> Grading and Land Development Phase <input type="checkbox"/> Streets and Utilities Phase <input type="checkbox"/> Inactive Construction	<input type="checkbox"/> Final Landscaping and Site Stabilization <input type="checkbox"/> Vertical Construction Phase
Activities completed:		
Approximate area of the site exposed (in acres):		

Review and update (as applicable) the QSP Implementation Checklist in Appendix VIII. Based on a review of this checklist and an evaluation of BMPs on-site complete the following:

Inspected the site for good site management (i.e., "housekeeping") measures implemented for <u>Construction Materials</u>		
Were any BMP deficiencies observed (i.e., BMPs requiring maintenance and repair)?	<input type="checkbox"/> Yes*	<input type="checkbox"/> No
*If yes, describe the deficiency:		
Describe any BMP Corrective Actions..		
Date	BMP Corrective Action Taken	
Date		
Date		
Date		

ORIGINAL - MAKE COPIES

Inspected the site for good site management (i.e., "housekeeping") measures implemented for <u>Waste Management</u> :	
Were any BMP deficiencies observed (i.e., BMPs requiring maintenance and repair)?	<input type="checkbox"/> Yes* <input type="checkbox"/> No
*If yes, describe below:	
Describe any BMP Corrective Actions.	
Date	BMP Corrective Action Taken
Date	
Date	
Date	

Inspected the site for good site management (i.e., "housekeeping") measures implemented for <u>Vehicle Storage and Maintenance</u> :	
Were any BMP deficiencies observed (i.e., BMPs requiring maintenance and repair)?	<input type="checkbox"/> Yes* <input type="checkbox"/> No
*If yes, describe below:	
Describe any BMP Corrective Actions.	
Date	BMP Corrective Action Taken
Date	
Date	
Date	

ORIGINAL - MAKE COPIES

Inspected the site for good site management (i.e., "housekeeping") measures implemented for Landscape Materials:

Were any BMP deficiencies observed (i.e., BMPs requiring maintenance and repair)? *If yes, describe below:	<input type="checkbox"/> Yes*	<input type="checkbox"/> No
---	-------------------------------	-----------------------------

Date	BMP Corrective Action Taken
Date	
Date	
Date	

Inspected the site for good site management (i.e., "housekeeping") measures implemented for Air Deposition:

Were any BMP deficiencies observed (i.e., BMPs requiring maintenance and repair)? *If yes, describe below:	<input type="checkbox"/> Yes*	<input type="checkbox"/> No
---	-------------------------------	-----------------------------

Date	BMP Corrective Action Taken
Date	
Date	
Date	

ORIGINAL - MAKE COPIES

Inspected the site for good site management (i.e., "housekeeping") measures implemented for <u>Non-Storm Water Discharges</u> :		
Were any BMP deficiencies observed (i.e., BMPs requiring maintenance and repair)? *If yes, describe below:	<input type="checkbox"/> Yes*	<input type="checkbox"/> No
Date	BMP Corrective Action Taken	
Date		
Date		
Date		

Inspected the site for good site management (i.e., "housekeeping") measures implemented for <u>Erosion Control</u> :		
	<input type="checkbox"/> Yes	<input type="checkbox"/> No
Were any BMP deficiencies observed (i.e., BMPs requiring maintenance and repair)? *If yes, describe below:	<input type="checkbox"/> Yes*	<input type="checkbox"/> No
Date	BMP Corrective Action Taken	
Date		
Date		
Date		

ORIGINAL - MAKE COPIES

Inspected the site for good site management (i.e., "housekeeping") measures implemented for <u>Sediment Control</u> : <input type="checkbox"/> Yes <input type="checkbox"/> No		
Were any BMP deficiencies observed (i.e., BMPs requiring maintenance and repair)? *If yes, describe below:	<input type="checkbox"/> Yes*	<input type="checkbox"/> No
Describe any BMP Corrective Actions.. <input type="checkbox"/> <input type="checkbox"/> <input type="checkbox"/> <input type="checkbox"/>		

Inspected the site for good site management (i.e., "housekeeping") measures implemented for <u>Run-on and Runoff Controls</u> : <input type="checkbox"/> Yes <input type="checkbox"/> No		
Were any BMP deficiencies observed (i.e., BMPs requiring maintenance and repair)? *If yes, describe below:	<input type="checkbox"/> Yes*	<input type="checkbox"/> No
Describe any BMP Corrective Actions. <input type="checkbox"/> <input type="checkbox"/> <input type="checkbox"/> <input type="checkbox"/>		

ORIGINAL - MAKE COPIES

List any corrective actions required, including any necessary changes to the SWPPP and the associated implementation dates:

Report the presence of noticeable odors/visible sheen on the surface of any discharges immediately to _____ at _____ and document observations below:

Were photographs taken during the inspection? Yes No
If yes, attach to this site inspection.

ORIGINAL - MAKE COPIES

Visual Observation (Inspection) Form for Non-Storm Water Discharges

(Store the Completed Form in Appendix XI.B)

Inspect each drainage area for the presence of (or indications of prior) unauthorized and authorize non-storm water discharges and their sources

Project Name _____

WDID Number: _____

Date and Time of Inspection _____

Current Weather Conditions _____

Name of Inspector _____

Inspector's Company/Title _____

QSP's Signature _____

Visual observation serves as the quarterly inspection for the following quarter (check which is applicable):

- January – March April - June July – September October – December

A visual observation (inspection) must document the presence or evidence of any non-storm water discharge (authorized or unauthorized).

Were any of these discharges observed at the time of the inspection

- YES NO

If yes, describe the discharge, their source and response taken to eliminate unauthorized non-sw discharges and to reduce or prevent pollutants from contacting non-sw discharges

Non-Storm Pollutant Water Characteristics	
Characteristic	Observation (Circle one)
Discolorations	Clear Brown Gray Yellow Red Other_____
Turbidity	Clear Cloudy Opaque
Floating or Suspended Materials?	None Vegetation Mulch Trash Foam Other_____
Sheen	None Slight Heavy
Any observed pollutants?	None Sewage Other_____
Possible sources?	

Were samples collected?

YES* NO Reason: _____

If yes, refer to Appendix X for sampling information.

**Visual Observation (Inspection) Form for a Qualifying Rain Event
(Store Complete Forms in Appendix XI.B)**

Project Name _____

WDID Number: _____

Date and Time of Inspection _____

Current Weather Conditions _____

Name of Inspector _____

Inspector's Company/Title _____

QSP's Signature _____

Inspection Type 48 hours prior to qualifying rain event Post-Rain (within 48 hours after a qualifying rain event)

Stored or contained storm water being discharged that is derived from and discharged subsequent to a qualifying rain event producing 1/2 inch or more at the time of discharge Other:

Storm Event Date: _____

Site Rain Gauge Reading at Time of Inspection: _____

NOAA Rain Gauge Reading at Time of Inspection: _____

NOAA Rain Gauge ID: _____

Inspection Observations **Are there any spills, leaks, or uncontrolled pollutant sources?
* If yes, describe below** _____ Yes* No

Are BMPs properly implemented in accordance with the SWPPP/REAP? Yes* No
 If yes, describe implemented corrective actions below

Do any storm water storage and containment areas have leaks? Yes* No
 If yes, describe below

Are BMPs were adequately designed, implemented, and effective? Yes* No

Inspect all discharge locations. If any of the characteristics are observed, describe the conditions and discharge location(s) below.

Storm Water Characteristics	
Characteristic	Observation (Circle applicable response)
Discolorations	None Brown Gray Yellow Red Other_____
Turbidity	Cloudy Opaque
Floating or Suspended Materials?	None Vegetation Mulch Trash Foam Other_____
Sheen	None Slight Heavy
Any observed pollutants? Possible sources?	None Sewage Other_____

Description of observations and location:

Is there a need for any additional BMPs? If so, describe below and inform the QSD that the SWPPP needs to be revised.

QSP IMPLEMENTATION CHECKLIST (Store Completed Forms in Appendix VII)

The QSP completes this checklist prior to each phase of construction.

Phase of construction: _____

A. Good Site Management ("Housekeeping") Measures for Construction Materials:

Construction Materials Measures ID No.	Construction Materials Measures	BMP Option		Alternative BMP Option *Describe why BMP was not implemented	
		Implemented?			
		Y	N*		
CM-b	Cover and berm loose stockpiled construction materials that are not actively being used (i.e. soil, spoils, aggregate, fly-ash, stucco, hydrated lime, etc.).	BMP-2-01 BMP-2-02 BMP-2-03 BMP-2-04 BMP-2-05 BMP-2-06			
CM-c	Store chemicals in watertight containers (with appropriate secondary containment to prevent any spillage or leakage) or in a storage shed (completely enclosed).	BMP-2-01 BMP-2-02 BMP-2-03 BMP-2-04 BMP-2-05 BMP-2-06 BMP-2-07 BMP-2-08			
CM-d	Minimize exposure of construction materials with precipitation.	BMP 1-07			

¹ QSP to review List of Potential Pollutant Sources in Appendix V and complete an Inventory of Potential Pollutant Sources planned to be used or stored at the project site in Appendix V as well.

B. Good Site Management ("Housekeeping") Measures for Waste Management:

Construction Materials Measures ID No.	Construction Materials Measures	BMP Option		Alternative BMP Option *Describe why BMP was not implemented	
		Implemented?			
		Y	N*		
WM-a	Prevent disposal of any rinse or wash waters or materials on impervious or pervious site surfaces or into the storm drain system.	BMP 3-02 BMP 3-03 BMP 3-04 BMP 3-05 BMP 3-06 BMP 3-07 BMP 3-08 BMP 3-09			
WM-b	Ensure the containment of sanitation facilities (e.g., portable toilets) to prevent discharges of pollutants to the storm water drainage system or receiving water.	BMP 2-07			
WM-c	Clean or replace sanitation facilities and inspecting them regularly for leaks and spills.	BMP 2-07			

QSP IMPLEMENTATION CHECKLIST

B. Good Site Management ("Housekeeping") Measures for Waste Management:

		BMP Option			Alternative BMP Option
WM-d	Cover waste disposal containers at the end of every business day and during a rain event.	BMP 2-01 BMP 2-02 BMP 2-03 BMP 2-04 BMP 2-05 BMP 2-06 BMP 2-07 BMP 2-08			
WM-e	Prevent discharges from waste disposal containers to the storm water drainage system or receiving water.	BMP 2-01 BMP 2-02 BMP 2-03 BMP 2-04 BMP 2-05 BMP 2-06 BMP 2-07 BMP 2-08			
WM-f	Contain and securely protect stockpiled waste material from wind and rain at all times unless actively being used.	BMP 1-08			
WM-g	Implement procedures that effectively address hazardous and non-hazardous spills.	BMP 2-03			
WM-h	Develop a spill response and implementation element of the SWPPP prior to commencement of construction activities. The SWPPP shall require that: <ul style="list-style-type: none"> Equipment and materials for cleanup of spills shall be available on site and that spills and leaks shall be cleaned up immediately and disposed of properly; and Appropriate spill response personnel are assigned and trained. 	BMP 2-03			
WM-i	Ensure the containment of concrete washout areas and other washout areas that may contain additional pollutants so there is no discharge into the underlying soil and onto the surrounding areas.	BMP 2-04			

C. Good Site Management ("Housekeeping") Measures for Vehicle Storage and Maintenance:

Construction Materials Measures		BMP Option			Alternative BMP Option
		Implemented?		*Describe why BMP was not implemented	
		Y	N*		
VSM-a	Prevent oil, grease, or fuel to leak in to the ground, storm drains or surface waters.	BMP 3-03 BMP 3-04 BMP 3-05			
VSM-b	Place all equipment or vehicles, which are to be fueled, maintained and stored in a designated area fitted with appropriate BMPs.	BMP 2-03 BMP 2-02 BMP 3-03 BMP 3-04			

QSP IMPLEMENTATION CHECKLIST

C. Good Site Management ("Housekeeping") Measures for Vehicle Storage and Maintenance:

		BMP Option			Alternative BMP Option
		Implemented?		*Describe why BMP was not implemented	
Y	N*				
VSM-c	Clean leaks immediately and disposing of leaked materials properly.	BMP 2-03			

D. Good Site Management ("Housekeeping") Measures for Landscape Materials:

Landscape Materials Measures		BMP Option			Alternative BMP Option
		Implemented?		*Describe why BMP was not implemented	
Y	N*				
LM-a	Contain stockpiled materials such as mulches and topsoil when they are not actively being used.	BMP 1-08 BMP 4-07 BMP 4-02			
LM-b	Contain fertilizers and other landscape materials when they are not actively being used.	BMP 1-08 BMP 2-01 BMP 2-02			
LM-c	Discontinuing the application of any erodible landscape material within 2 days before a forecasted rain event ² or during periods of precipitation.	BMP 3-07 BMP 2-02			
LM-d	Apply erodible landscape material at quantities and application rates according to manufacture recommendations or based on written specifications by knowledgeable and experienced field personnel.	BMP 3-07 BMP 2-02			
LM-e	Stacking erodible landscape material on pallets and covering or storing such materials when not being used or applied.	BMP 3-07 BMP 2-01 BMP 2-02			

² Excerpt from CGP – 50% or greater chance of producing precipitation.

F. Good Site Management ("Housekeeping") Measures for Air Deposition:

Air Deposition		BMP Option			Alternative BMP Option
		Implemented?		*Describe why BMP was not implemented	
Y	N*				
AD-a	Control the air deposition of site materials and from site operations. Such particulates can include, but are not limited to, sediment, nutrients, trash, metals, bacteria, oil and grease and organics.	BMP 4-08			

QSP IMPLEMENTATION CHECKLIST

Non-Storm Water Management:		BMP Option		Alternative BMP Option
		Implemented?		*Describe why BMP was not implemented
		Y	N*	
NSWM-a	Implement measures to control all non-storm water discharges during construction.	BMP 3-03 BMP 3-02 BMP 1-07		
NSWM-b	Wash vehicles in such a manner as to prevent non-storm water discharges to surface waters or MS4 drainage systems.	BMP 3-03		
NSWM-c	Clean streets in such a manner as to prevent non-storm water discharges from reaching surface water or MS4 drainage systems.	BMP 3-02 BMP 1-07		

² Inactive areas of construction are areas of construction activity that have been disturbed and are not scheduled to be re-disturbed for at least 14 days.

Erosion Control		BMP Option		Alternative BMP Option
		Implemented?		*Describe why BMP was not implemented
		Y	N*	
ECM-a	Effective wind erosion control	BMP 4-08		
ECM-b	Provide effective soil cover for inactive ³ areas and all finished slopes, open space, utility backfill, and completed lots.	BMP 4-02 BMP 4-03 BMP 4-04 BMP 4-05 BMP 4-06 BMP 4-07		
ECM-c	Limit the use of plastic materials when more sustainable, environmentally friendly alternatives exist. Where plastic materials are deemed necessary, the discharger shall consider the use of plastic materials resistant to solar degradation.	BMP 4-07		

³ Inactive areas of construction are areas of construction activity that have been disturbed and are not scheduled to be re-disturbed for at least 14 days.

QSP IMPLEMENTATION CHECKLIST

Sediment Control: SC-c, SC-d, SC-e, SC-f, SC-g, SC-h are not applicable to Risk Level 1 projects. If the project is a Risk Level 1, delete SC-c, SC-d, SC-e, SC-f, SC-g, SC-h in the table below. SC-h also does not apply to Risk Level 2 projects; delete this BMP if the project is Risk Level 2.

Sediment Control		BMP Option		Alternative BMP Option
		Implemented?		*Describe why BMP was not implemented
		Y	N*	
SC-a	Establish and maintain effective perimeter controls and stabilize all construction entrances and exits to sufficiently control erosion and sediment discharges from the site.	BMP 1-01 BMP 1-02 BMP 1-03 BMP 1-04 BMP 1-05 BMP 1-06 BMP 1-07 BMP 1-08		
SC-b	On sites where sediment basins are to be used, at a minimum, design sediment basins according to the method provided in CASQA's Construction BMP Guidance Handbook	N/A		
SC-c	Implement appropriate erosion control BMPs (runoff control and soil stabilization) in conjunction with sediment control BMPs for areas under active ⁴ construction.	BMP 4-02 BMP 4-03 BMP 4-04 BMP 4-05 BMP 4-06 BMP 4-07		
SC-d	Apply linear sediment controls along the toe of the slope, face of the slope, and at the grade breaks of exposed slopes to comply with sheet flow lengths ⁵ in accordance with Table 1.	BMP 1-02 BMP 1-03		

⁴ Active areas of construction are areas undergoing land surface disturbance. This includes construction activity during the preliminary stage, mass grading stage, streets and utilities stage, and the vertical construction stage.

⁵ Sheet flow length is the length that shallow, low velocity flow travels across a site.

SC-e	Ensure that construction activity traffic to and from the project is limited to entrances and exits that employ effective controls to prevent offsite tracking of sediment.	BMP 1-07		
SC-f	Ensure that all storm drain inlets and perimeter controls, runoff control BMPs, and pollutant controls at entrances and exits (e.g. tire washoff locations) are maintained and protected from activities that reduce their effectiveness.	BMP 1-06		

QSP IMPLEMENTATION CHECKLIST

		BMP Option			Alternative BMP Option
SC-g	Inspect on a daily basis all immediate access roads daily. At a minimum daily (when necessary) and prior to any rain event, the discharger shall remove any sediment or other construction activity-related materials that are deposited on the roads (by vacuuming or sweeping).	BMP 1-07			
SC-h	The Regional Water Board may require Risk Level 3 dischargers to implement additional site-specific sediment control requirements if the implementation of the other requirements in this section are not adequately protecting the receiving waters.	N/A			

Excerpt from the CGP Attachment D:

Excerpt from the CGP Attachment E:

Table 1 - Critical Slope/Sheet Flow Length Combinations

Slope Percentage	Sheet flow length not to exceed
0-25%	20 feet
25-50%	15 feet
Over 50%	10 feet

Run-on and Run-off Controls		Applicable to Project?		Alternative BMP Option
		Y	N*	*Describe why BMP was not implemented
RRC-a	Effectively manage all run-on, all runoff within the site and all runoff that discharges off the site.			
RRC-b	Run-on from off-site shall be directed away from all disturbed areas or shall collectively be in compliance with the effluent limitation in the CGP.			

**SAMPLING EVENT WORKSHEET
(Store Completed Forms in Appendix XI.D)**

Name of Inspector: _____

Storm Event Date(s): _____

Rain Gauge Readings: _____ Risk Level: _____

Samples collected:

Qualifying Rain Event

Samples not collected:

Non-Target Storm Event – Event was not preceded by 72 hours of dry weather

Non-Target Storm Event – Event occurred outside of daylight hours

False Alert – Predicted storm event never started or did not produce runoff

Compliance Storm Event Exception

Dangerous Conditions

Outside Business Hours

Storm Start Time:	_____	Storm End Time:	_____
-------------------	-------	-----------------	-------

Runoff Start Time:	_____	Total Precipitation:	_____
--------------------	-------	----------------------	-------

Check All That Apply (complete form for each sampling location per day):

Dischargers shall ensure that the grab samples collected of stored or contained storm water are from discharges subsequent to a qualifying rain event (producing precipitation of ½ inch or more with a 48 hour or greater period between rain events)

Discharge run-off location

Run-on location

ATS discharge location

Non-visible pollutant location

3 samples per day:

Sample 1

Sample 2

Sample 3

Effluent Sampled for:

pH

Turbidity

Any additional parameters for which monitoring is required by the Regional Water Board:

Who collected the sample? Name, company, phone number? Rain gauge readings?

Name:

Company:

Phone Number

Who collected the sample? Name, company, phone number? Rain gauge readings?

Name:

Company:

Phone Number

Who collected the sample? Name, company, phone number? Rain gauge readings?

Name:

Company:

Phone Number

Who collected the sample? Name, company, phone number? Rain gauge readings?

Name:

Company:

Phone Number

ORIGINAL - MAKE COPIES

For Monitoring Location:

		Sampler Name	Time Sample Taken	Results	Daily Average	Was there an NAL Exceedance (Y ¹ / N ²)	Was there an NEL Violation (Y/N) ³
pH	1 st Sample						
	2 nd Sample						
	3 rd Sample						
Turbidity	1 st Sample						
	2 nd Sample						
	3 rd Sample						
SSC							

¹ Refer to Appendix X.7 for required action.
² No further action required.
³ Refer to Appendix X.8 for required action.

ORIGINAL - MAKE COPIES

**Numeric Effluent Limitation (NEL) Violation Report
(Store Completed Form in Appendix XVII)**

Project Name _____

WDID Number _____

Risk Level _____

Attach the following documents to this NEL Violation Report:

- Description of the current onsite BMPs and the proposed corrective actions taken to manage the NEL exceedance.
- A copy of the analytical method(s), method reporting unit(s), and method detection limit(s) of each analytical parameter (from Appendix X)
- A copy of the completed Visual Observation (Inspection) form for the sampling event (from Appendix X.B)

Date and Time of Sampling Event _____

Weather Conditions _____

Name of NEL Preparer _____

NEL Preparer's Company/Title _____

Sample Identification Number	Location	Parameter pH/Turbidity	Reporting Units	Result

Daily Average Value: _____ NEL Limitation: _____

ORIGINAL - MAKE COPIES

Describe the current BMPs associated with the effluent sample that exceeded the NEL:

Describe the proposed corrective actions taken to manage the effluent associated with the NEL exceedance:

Any person signing documents under Section IV.I of the CGP shall make the following certification:

"I certify under penalty of law that this document and all attachments were prepared under my direction or supervision in accordance with a system designed to assure that qualified personnel properly gather and evaluate the information submitted. Based on my inquiry of the person or persons who manage the system or those persons directly responsible for gathering the information, to the best of my knowledge and belief, the information submitted is, true, accurate, and complete. I am aware that there are significant penalties for submitting false information, including the possibility of fine and imprisonment for knowing violations."

Name of LRP *

Title

Company

Telephone Number

Signature

Date

*or approved signatory.

ORIGINAL - MAKE COPIES

**Numeric Action Level (NAL) Exceedance Report
(Store Completed Forms in Appendix XVII)**

Project Name _____

WDID Number _____

Risk Level _____

Attach the following documents to this NAL Exceedance Report:

- The analytical method(s), method reporting unit(s), and method detection limit(s) of each analytical parameter (Appendix X)
- The completed Visual Observation (Inspection) form and the sampling event worksheet (Appendix XI)

Date and Time of Sampling Event _____

Weather Conditions _____

Name of NAL Preparer _____

NAL Preparer's Company/Title _____

Sample Identification Number	Location	Parameter pH/Turbidity	Reporting Units	Result

Daily Average Value: _____ NAL Limitation: _____

Describe the current BMPs associated with the effluent sample that exceeded the NAL

Were any corrective actions taken? If yes, describe below:

ORIGINAL - MAKE COPIES

LEAKS AND SPILLS DOCUMENTATION (Completed Form Stored in Appendix XIV)

Immediately report any leaks or spills to the LRP

Name _____

Phone Number _____

Date & Time of incident or
time of discovery of spill: _____

Material Spilled: Liquid Solid Gas

What is it used for? _____

Known dangerous quantities? _____

MSDS available YES * NO

If yes, consult the MSDS sheet for appropriate handling, storage and disposal practices

Chemical or Trade Name _____

Estimate Amount _____ *Gallons if liquid*
 _____ *Pounds if solid or gas*
 _____ *Leaked or Spilled*

Potential dangers (as appropriate) Fire Explosion Toxic Fumes & Fluids Threat to life or property

Other (describe): _____

Cause and source of incident (e.g., human error, corrosion):

Secondary Containment and Spill Kit Inventory (Store Completed Form in Appendix XVIII)

To be completed by the QSP

- Equipment and materials for cleanup of spills shall be available on site and spills and leaks shall be cleaned up **immediately** and the materials used to clean up the spills shall be disposed of properly; and
- Ensure appropriate spill response personnel are assigned and trained.
- Ensure the containment of washout areas that may contain additional pollutants so that there is no discharge into the underlying soil and/or surrounding areas.

The following spill control equipment can be found on-site:

Quantity ¹	Description ²	Location ³	Absorbent Capacity (Gallons) ⁴

1 – Number of spill kits or product
2 - Contents of spill kit or product

3 – Storage location of spill kit or product
4 – Absorbent capacity of the spill kit or product

Note: Spill response kits come from a variety of suppliers. Kit contents and absorbent capacity may vary from supplier’s description.

The following secondary containment equipment can be found on-site:

Description of Material Stored in Secondary Containment ⁵	Location ⁶	Type of Containment/Enclosure ⁷	Volume	
			Maximum Storage/Containment ⁸	Spill Potential ⁹

5- For example, paint, oil, lubricant, solvent, etc.

6- Location of secondary containment

7- Description of the secondary containment enclosure. For example, poly-pack, poly-pallet, cabinet, visqueen-lined sump.

8- Capacity of the secondary device (usually identified on the device or can be obtained from the manufacturer)

9- Quantity of material (in gallons) stored in the secondary containment

Appendix XIII List of Responsible Parties

PROJECT: _____

WDID
NUMBER: _____

<input type="checkbox"/> LEGALLY RESPONSIBLE PARTIES (LRP) <input type="checkbox"/> THE LRP's APPROVED SIGNATORY			
AREA OF RESPONSIBILITY:	Construction and Engineering Sunrise Powerlink Project		
NAME			TITLE:
COMPANY NAME:			
ADDRESS			
CITY		STATE	ZIP
TELEPHONE			
EMERGENCY TELEPHONE			
FAX			
E-MAIL			
QUALIFIED SWPPP DEVELOPER (QSD): RESPONSIBLE FOR PREPARING THE SWPPP:			
NAME			TITLE:
COMPANY NAME:			
ADDRESS			
CITY		STATE	ZIP
TELEPHONE			
EMERGENCY TELEPHONE			
FAX			
E-MAIL			
ADDITIONAL QSD:			
AREA OF RESPONSIBILITY:			
NAME			TITLE:
COMPANY NAME:			
ADDRESS			
CITY		STATE	ZIP
TELEPHONE			
EMERGENCY TELEPHONE			
FAX			
E-MAIL			
START DATE			END DATE

QUALIFIED SWPPP PRACTITIONER (QSP):			
AREA OF RESPONSIBILITY:			
NAME		TITLE:	
COMPANY NAME:			
ADDRESS			
CITY		STATE	ZIP
TELEPHONE			
EMERGENCY TELEPHONE			
FAX			
E-MAIL			
START DATE		END DATE	

ADDITIONAL QSP:			
AREA OF RESPONSIBILITY:			
NAME		TITLE:	
COMPANY NAME:			
ADDRESS			
CITY		STATE	ZIP
TELEPHONE			
EMERGENCY TELEPHONE			
FAX			
E-MAIL			
START DATE		END DATE	

SPILL RESPONSE PERSONNEL			
NAME		TITLE:	
ADDRESS			
CITY		STATE	ZIP
TELEPHONE			
EMERGENCY TELEPHONE			
FAX			
E-MAIL			
START DATE		END DATE	

SPILL RESPONSE PERSONNEL			
NAME		TITLE:	
ADDRESS			
CITY		STATE	ZIP
TELEPHONE			
EMERGENCY TELEPHONE			
FAX			
E-MAIL			
START DATE		END DATE	

SPILL RESPONSE PERSONNEL			
NAME		TITLE:	
ADDRESS			
CITY		STATE	ZIP
TELEPHONE			
EMERGENCY TELEPHONE			
FAX			
E-MAIL			
START DATE		END DATE	

SPILL RESPONSE PERSONNEL			
NAME		TITLE:	
ADDRESS			
CITY		STATE	ZIP
TELEPHONE			
EMERGENCY TELEPHONE			
FAX			
E-MAIL			
START DATE		END DATE	

STORM WATER SAMPLING AGENT:			
CONTACT PERSON		TITLE:	
ADDRESS			
CITY		STATE	ZIP
TELEPHONE			
EMERGENCY TELEPHONE			
FAX			
E-MAIL			
START DATE		END DATE	

STORM WATER SAMPLING AGENT:			
CONTACT PERSON		TITLE:	
ADDRESS			
CITY		STATE	ZIP
TELEPHONE			
EMERGENCY TELEPHONE			
FAX			
E-MAIL			
START DATE		END DATE	

STORM WATER SAMPLING AGENT:			
CONTACT PERSON		TITLE:	
ADDRESS			
CITY		STATE	ZIP
TELEPHONE			
EMERGENCY TELEPHONE			
FAX			
E-MAIL			
START DATE		END DATE	

STORM WATER SAMPLING AGENT:			
CONTACT PERSON		TITLE:	
ADDRESS			
CITY		STATE	ZIP
TELEPHONE			
EMERGENCY TELEPHONE			
FAX			
E-MAIL			
START DATE		END DATE	

REGIONAL BOARD CONTACT INFORMATION		RQWQB NAME:	
CONTACT PERSON		TITLE:	
ADDRESS			
CITY		STATE	ZIP
TELEPHONE			
EMERGENCY TELEPHONE			
FAX			
E-MAIL			

LOCAL STORM WATER MANAGEMENT AGENCY		AGENCY NAME:	
CONTACT PERSON		TITLE:	
ADDRESS			
CITY		STATE	ZIP
TELEPHONE			
EMERGENCY TELEPHONE			
FAX			
E-MAIL			

<input type="checkbox"/> CONTRACTOR <input type="checkbox"/> SUBCONTRACTOR <input type="checkbox"/> INDIVIDUAL DIRECTED BY QSP <input type="checkbox"/> OTHER			
PLEASE CHECK APPROPRIATE BOX ABOVE. IF "OTHER", PLEASE INDICATE:			
COMPANY NAME			
CONTACT PERSON		TITLE:	
ADDRESS			
CITY		STATE	ZIP
TELEPHONE			
EMERGENCY TELEPHONE			
FAX			
E-MAIL			
START DATE		END DATE	

<input type="checkbox"/> CONTRACTOR <input type="checkbox"/> SUBCONTRACTOR <input type="checkbox"/> INDIVIDUAL DIRECTED BY QSP <input type="checkbox"/> OTHER			
PLEASE CHECK APPROPRIATE BOX ABOVE. IF "OTHER", PLEASE INDICATE:			
NAME			TITLE:
ADDRESS			
CITY		STATE	ZIP
TELEPHONE			
EMERGENCY TELEPHONE			
FAX			
E-MAIL			
START DATE		END DATE	

<input type="checkbox"/> CONTRACTOR <input type="checkbox"/> SUBCONTRACTOR <input type="checkbox"/> INDIVIDUAL DIRECTED BY QSP <input type="checkbox"/> OTHER			
PLEASE CHECK APPROPRIATE BOX ABOVE. IF "OTHER", PLEASE INDICATE:			
NAME			TITLE:
ADDRESS			
CITY		STATE	ZIP
TELEPHONE			
EMERGENCY TELEPHONE			
FAX			
E-MAIL			
START DATE		END DATE	

<input type="checkbox"/> CONTRACTOR <input type="checkbox"/> SUBCONTRACTOR <input type="checkbox"/> INDIVIDUAL DIRECTED BY QSP <input type="checkbox"/> OTHER				
PLEASE CHECK APPROPRIATE BOX ABOVE. IF "OTHER", PLEASE INDICATE:				
NAME			TITLE:	
ADDRESS				
CITY	STATE	ZIP		
TELEPHONE				
EMERGENCY TELEPHONE				
FAX				
E-MAIL				
START DATE	END DATE			

<input type="checkbox"/> CONTRACTOR <input type="checkbox"/> SUBCONTRACTOR <input type="checkbox"/> INDIVIDUAL DIRECTED BY QSP <input type="checkbox"/> OTHER				
PLEASE CHECK APPROPRIATE BOX ABOVE. IF "OTHER", PLEASE INDICATE:				
NAME			TITLE:	
ADDRESS				
CITY	STATE	ZIP		
TELEPHONE				
EMERGENCY TELEPHONE				
FAX				
E-MAIL				
START DATE	END DATE			

<input type="checkbox"/> CONTRACTOR <input type="checkbox"/> SUBCONTRACTOR <input type="checkbox"/> INDIVIDUAL DIRECTED BY QSP <input type="checkbox"/> OTHER				
PLEASE CHECK APPROPRIATE BOX ABOVE. IF "OTHER", PLEASE INDICATE:				
NAME			TITLE:	
ADDRESS				
CITY	STATE	ZIP		
TELEPHONE				
EMERGENCY TELEPHONE				
FAX				
E-MAIL				
START DATE	END DATE			

<input type="checkbox"/> CONTRACTOR <input type="checkbox"/> SUBCONTRACTOR <input type="checkbox"/> INDIVIDUAL DIRECTED BY QSP <input type="checkbox"/> OTHER			
PLEASE CHECK APPROPRIATE BOX ABOVE. IF "OTHER", PLEASE INDICATE:			
NAME			TITLE:
ADDRESS			
CITY	STATE	ZIP	
TELEPHONE			
EMERGENCY TELEPHONE			
FAX			
E-MAIL			
START DATE			END DATE

<input type="checkbox"/> CONTRACTOR <input type="checkbox"/> SUBCONTRACTOR <input type="checkbox"/> INDIVIDUAL DIRECTED BY QSP <input type="checkbox"/> OTHER			
PLEASE CHECK APPROPRIATE BOX ABOVE. IF "OTHER", PLEASE INDICATE:			
NAME			TITLE:
ADDRESS			
CITY	STATE	ZIP	
TELEPHONE			
EMERGENCY TELEPHONE			
FAX			
E-MAIL			
START DATE			END DATE

<input type="checkbox"/> CONTRACTOR <input type="checkbox"/> SUBCONTRACTOR <input type="checkbox"/> INDIVIDUAL DIRECTED BY QSP <input type="checkbox"/> OTHER			
PLEASE CHECK APPROPRIATE BOX ABOVE. IF "OTHER", PLEASE INDICATE:			
NAME			TITLE:
ADDRESS			
CITY	STATE	ZIP	
TELEPHONE			
EMERGENCY TELEPHONE			
FAX			
E-MAIL			
START DATE			END DATE

**BMP SELECTION WORKSHEET
(Store Completed Forms in Appendix VII)**

BMP No.	BMP Options (Additional BMPs shall be implemented as necessary to protect water quality as determined by field conditions)	Selected BMPs	Option 1	Option 2
Section 1 Sediment Controls				
BMP-1-02	Silt Fence	<input type="checkbox"/>	*_*_*	-SF-
BMP-1-03	Fiber Rolls	<input type="checkbox"/>	- - -	-FR-
BMP-1-04	Gravel Bag Berm	<input type="checkbox"/>	o o o	~GBB~
BMP-1-05	Sand Bag Barrier	<input type="checkbox"/>	• • •	-SBB-
BMP-1-06	Storm Drain Inlet Protection	<input type="checkbox"/>	□	-SDIP-
BMP-1-07	Tracking Controls	<input type="checkbox"/>	■	-TC-
BMP-1-08	Stockpile Management	<input type="checkbox"/>	◇	-SM-
Other – User Defined	BMP Description	<input type="checkbox"/>		
The following rows have been provided to add additional BMPs that may be required during the course of the project. QSD to provide this information as applicable.				
Other – User Defined	BMP Description:	<input type="checkbox"/>		
Section 2 Waste Management and Material Controls				
BMP-2-01	Material Delivery and Storage	<input type="checkbox"/>	» » » » »	-MDS-
BMP-2-02	Material Use	<input type="checkbox"/>	☀	-MV-
BMP-2-03	Spill Control	<input type="checkbox"/>	⬡	-SC-
BMP-2-04	Solid Waste Management	<input type="checkbox"/>	o-o-o	-SWM-
BMP-2-05	Hazardous Materials/Waste Management	<input type="checkbox"/>	▴	-HM/WM-
BMP-2-06	Contaminated Soil Management	<input type="checkbox"/>	⊙	-CSM-

BMP SELECTION WORKSHEET
(Store Completed Forms in Appendix VII)

BMP No.	BMP Options (Additional BMPs shall be implemented as necessary to protect water quality as determined by field conditions)	Selected BMPs	Option 1	Option 2
BMP-2-07	Sanitary/Septic Waste Management	<input type="checkbox"/>	▲	-S/SWM-
BMP-2-08	Liquid Waste Management	<input type="checkbox"/>	△	-LWM-
The following rows have been provided to add additional BMPs that may be required during the course of the project. QSD to provide this information as applicable.				
Other – User Defined	BMP Description:	<input type="checkbox"/>		
Section 3 Non-Storm Water Discharge Controls				
BMP-3-01	Dewatering Operations	<input type="checkbox"/>	☆	-DW-
BMP-3-02	Paving Operations	<input type="checkbox"/>	●-●-●	-PO-
BMP-3-03	Vehicle and Equipment Washing	<input type="checkbox"/>	⬠	-VEW-
BMP-3-04	Vehicle and Equipment Fueling	<input type="checkbox"/>	⬡	-VEF-
BMP-3-05	Concrete/Coring/Saw Cutting and Drilling Waste Management	<input type="checkbox"/>	⊗	-CWM-
BMP-3-06	Dewatering Utility Substructures and Vaults	<input type="checkbox"/>	▶	-DUS&V-
BMP-3-07	Vegetation Management including Mechanical and Chemical Weed Control	<input type="checkbox"/>	↔	-VM-
BMP-3-08	Over-Water Protection	<input type="checkbox"/>	⬢	-OWP-
BMP-3-09	Removal of Utility Location/Mark-Out Paint	<input type="checkbox"/>	⊕	-UL-
The following rows have been provided to add additional BMPs that may be required during the course of the project. QSD to provide this information as applicable.				
Other – User Defined	BMP Description:	<input type="checkbox"/>		

**BMP SELECTION WORKSHEET
(Store Completed Forms in Appendix VII)**

BMP No.	BMP Options (Additional BMPs shall be implemented as necessary to protect water quality as determined by field conditions)	Selected BMPs	Option 1	Option 2
Section 4 Erosion Control and Soil Stabilization				
BMP-4-01	Preservation of Existing Vegetation	<input type="checkbox"/>	▼	-PEV-
BMP-4-02	Temporary Soil Stabilization	<input type="checkbox"/>	■-■-■	-TSS-
BMP-4-03	Hydraulic Mulch	<input type="checkbox"/>	≈≈≈	-M-
BMP-4-04	Hydroseeding	<input type="checkbox"/>	>>>>	-BP-
BMP-4-05	Soil Binders	<input type="checkbox"/>	┌┌┌┌	-SOS-
BMP-4-06	Straw Mulch	<input type="checkbox"/>	««««	-S-
BMP-4-07	Geotextiles, Plastic Covers and Erosion Control Blankets/Mats	<input type="checkbox"/>	□□□□	-ECB-
BMP-4-08	Dust (Wind Erosion) Control	<input type="checkbox"/>	-WE-
The following rows have been provided to add additional BMPs that may be required during the course of the project. QSD to provide this information as applicable.				
Other – User Defined	BMP Description:	<input type="checkbox"/>		

ORIGINAL - MAKE COPIES

**BMP SELECTION WORKSHEET
(Store Completed Forms in Appendix VII)**

BMP No.	BMP Options (Additional BMPs shall be implemented as necessary to protect water quality as determined by field conditions)	Selected BMPs	Option 1	Option 2
Section 5 Streambed Discharges and Crossings				
CASQA EC-10	Velocity Dissipation Devices	<input type="checkbox"/>	≡≡≡≡	-VDD-
CASQA EC-12	Streambank Stabilization	<input type="checkbox"/>	~~~~	-SBS-
CASQA NS-4	Temporary Stream Crossing	<input type="checkbox"/>	<<<<	-TSC-
CASQA NS-5	Clear Water Diversion	<input type="checkbox"/>	+++++	-CWD-
The following rows have been provided to add additional BMPs that may be required during the course of the project. QSD to provide this information as applicable.				
Other – User Defined	BMP Description:	<input type="checkbox"/>		

Appendix II

Construction General Permit



Linda S. Adams
Secretary for
Environmental Protection

State Water Resources Control Board



Arnold Schwarzenegger
Governor

Division of Water Quality

1001 I Street • Sacramento, California 95814 • (916) 341-5455
Mailing Address: P.O. Box 100 • Sacramento, California • 95812-0100
Fax (916) 341-5463 • <http://www.waterboards.ca.gov>

NATIONAL POLLUTANT DISCHARGE ELIMINATION SYSTEM (NPDES)
GENERAL PERMIT FOR
STORM WATER DISCHARGES
ASSOCIATED WITH CONSTRUCTION AND LAND DISTURBANCE
ACTIVITIES

ORDER NO. 2009-0009-DWQ
NPDES NO. **CAS000002**

This Order was adopted by the State Water Resources Control Board on:	September 2, 2009
This Order shall become effective on:	July 1, 2010
This Order shall expire on:	September 2, 2014

IT IS HEREBY ORDERED, that this Order supersedes [Order No. 99-08-DWQ](#) except for enforcement purposes. The Discharger shall comply with the requirements in this Order to meet the provisions contained in Division 7 of the California Water Code (commencing with section 13000) and regulations adopted thereunder, and the provisions of the federal Clean Water Act and regulations and guidelines adopted thereunder.

I, Jeanine Townsend, Clerk to the Board, do hereby certify that this Order with all attachments is a full, true, and correct copy of an Order adopted by the State Water Resources Control Board, on September 2, 2009.

AYE: Vice Chair Frances Spivy-Weber
Board Member Arthur G. Baggett, Jr.
Board Member Tam M. Doduc

NAY: Chairman Charles R. Hoppin

ABSENT: None

ABSTAIN: None

Jeanine Townsend
Clerk to the Board

List of Documents included in this single file saved in pdf format on September 22, 2009:

- Fact Sheet
- Order
- Attachment A – Linear Underground/Overhead Requirements
- Attachment A.1 – LUP Project Type Determination
- Attachment A.2 – LUP Permit Registration Documents
- Attachment B – Permit Registration Documents
- Attachment C – Risk Level 1 Requirements
- Attachment D – Risk Level 2 Requirements
- Attachment E – Risk Level 3 Requirements
- Attachment F – Active Treatment System Requirements
- Appendix 1 – Risk Determination Worksheet and Sediment-related 303d List
- Appendix 2 – Post-Construction Water Balance
- Appendix 2.1 – Post-Construction Water Balance Calculator
- Appendix 3 - Bioassessment Monitoring Guidelines
- Appendix 4 – Adopted/Implemented Sediment and Non-sediment TMDLs
- Appendix 5 – Glossary
- Appendix 6 - Acronym List
- Appendix 7 – State and Regional Water Board Contacts



State Water Resources Control Board

Division of Water Quality

1001 I Street • Sacramento, California 95814 • (916) 341-5455

Mailing Address: P.O. Box 100 • Sacramento, California • 95812-0100

Fax (916) 341-5463 • <http://www.waterboards.ca.gov>



Linda S. Adams
Secretary for
Environmental Protection

Arnold Schwarzenegger
Governor

CONSTRUCTION GENERAL PERMIT FACT SHEET TABLE OF CONTENTS

I.	BACKGROUND	1
A.	History	1
B.	Legal Challenges and Court Decisions.....	1
C.	Blue Ribbon Panel of Experts and Feasibility of Numeric Effluent Limitations	3
D.	Summary of Panel Findings on Construction Activities	4
E.	How the Panel's Findings are Used in this General Permit	5
F.	Summary of Significant Changes in This General Permit	5
II.	RATIONALE	7
A.	General Permit Approach.....	7
B.	Construction Activities Covered.....	7
C.	Construction Activities Not Covered	9
D.	Obtaining and Terminating Permit Coverage	11
E.	Discharge Prohibitions	12
F.	Effluent Standards for All Types of Discharges.....	13
G.	Receiving Water Limitations	20
H.	Training Qualifications and Requirements	21
I.	Sampling, Monitoring, Reporting and Record Keeping.....	21
J.	Risk Determination.....	28
K.	ATS Requirements.....	36
L.	Post-Construction Requirements	37
M.	Storm Water Pollution Prevention Plans	45
N.	Regional Water Board Authorities.....	47

LIST OF TABLES

Table 1 - Regional Water Board Basin Plans, Water Quality Objectives for Turbidity	16
Table 2 - Results of Ecoregion Analysis	16
Table 3 – ACL Sampling Data taken by Regional Water Board Staff.....	17
Table 4 - Required Monitoring Elements for Risk Levels.....	21
Table 5 - Storm Water Effluent Monitoring Requirements by Risk Level	23
Table 6 - Receiving Water Monitoring Requirements	26
Table 7 - Combined Risk Level Matrix	30
Table 8 -National Oceanic and Atmospheric Administration (NOAA) Definition of Probability of Precipitation (PoP)	32
Table 9 - Qualified SWPPP Developer/ Qualified SWPPP Practitioner Certification Criteria.....	46

LIST OF FIGURES

Figure 1 -Statewide Map of K * LS.....	29
Figure 2 - Suite of Storm Events	38
Figure 3 - Northern CA (2009) Counties / Cities With SUSMP-Plus Coverage.....	39
Figure 4 - Southern CA (2009) Counties / Cities With SUSMP-Plus Coverage	40
Figure 5 - Schematic of the Lane Relationship	42
Figure 6 - Channel Changes Associated with Urbanization	43

I. BACKGROUND

A. History

In 1972, the Federal Water Pollution Control Act (also referred to as the Clean Water Act [CWA]) was amended to provide that the discharge of pollutants to waters of the United States from any point source is unlawful unless the discharge is in compliance with a National Pollutant Discharge Elimination System (NPDES) permit. The 1987 amendments to the CWA added Section 402(p), which establishes a framework for regulating municipal and industrial storm water discharges under the NPDES Program. On November 16, 1990, the U.S. Environmental Protection Agency (USEPA) published final regulations that established storm water permit application requirements for specified categories of industries. The regulations provide that discharges of storm water to waters of the United States from construction projects that encompass five or more acres of soil disturbance are effectively prohibited unless the discharge is in compliance with an NPDES Permit. Regulations (Phase II Rule) that became final on December 8, 1999 lowered the permitting threshold from five acres to one acre.

While federal regulations allow two permitting options for storm water discharges (Individual Permits and General Permits), the State Water Board has elected to adopt only one statewide General Permit at this time that will apply to most storm water discharges associated with construction activity.

On August 19, 1999, the State Water Board reissued the General Construction Storm Water Permit (Water Quality Order 99-08-DWQ). On December 8, 1999 the State Water Board amended Order 99-08-DWQ to apply to sites as small as one acre.

The General Permit accompanying this fact sheet regulates storm water runoff from construction sites. Regulating many storm water discharges under one permit will greatly reduce the administrative burden associated with permitting individual storm water discharges. To obtain coverage under this General Permit, dischargers shall electronically file the Permit Registration Documents (PRDs), which includes a Notice of Intent (NOI), Storm Water Pollution Prevention Plan (SWPPP), and other compliance related documents required by this General Permit and mail the appropriate permit fee to the State Water Board. It is expected that as the storm water program develops, the Regional Water Quality Control Boards (Regional Water Boards) may issue General Permits or Individual Permits containing more specific permit provisions. When this occurs, this General Permit will no longer regulate those dischargers.

B. Legal Challenges and Court Decisions

1. Early Court Decisions

Shortly after the passage of the CWA, the USEPA promulgated regulations exempting most storm water discharges from the NPDES permit requirements. (See 40 C.F.R. § 125.4 (1975); see also *Natural Resources Defense Council v. Costle* (D.C. Cir. 1977) 568 F.2d 1369, 1372 (*Costle*); *Defenders of Wildlife v. Browner* (9th Cir. 1999) 191 F.3d 1159, 1163 (*Defenders of Wildlife*)). When environmental groups challenged this exemption in federal court, the District of Columbia Court of Appeals invalidated the regulation, holding that the USEPA “does not have authority to exempt categories of point sources from the permit requirements of [CWA] § 402.” (*Costle*, 568 F.2d at 1377.) The *Costle* court rejected the USEPA’s argument that effluent-based storm sewer regulation was administratively infeasible because of the variable nature of storm water pollution and the number of affected storm sewers throughout the country. (*Id.* at 1377-82.) Although the court acknowledged the practical problems relating to storm sewer regulation, the court found the USEPA had the flexibility under the CWA to design regulations that would overcome these problems. (*Id.* at 1379-83.) In particular, the court pointed to general permits and permits based on requiring best management practices (BMPs).

During the next 15 years, the USEPA made numerous attempts to reconcile the statutory requirement of point source regulation with the practical problem of regulating possibly millions of diverse point source discharges of storm water. (See *Defenders of Wildlife*, 191 F.3d at 1163; see also Gallagher, Clean Water Act in Environmental Law Handbook (Sullivan, edit., 2003) p. 300 (Environmental Law Handbook); Eisen, *Toward a Sustainable Urbanism: Lessons from Federal Regulation of Urban Storm Water Runoff* (1995) 48 Wash. U.J. Urb. & Contemp. L.1, 40-41 [Regulation of Urban Storm Water Runoff].)

In 1987, Congress amended the CWA to require NPDES permits for storm water discharges. (See CWA § 402(p), 33 U.S.C. § 1342(p); *Defenders of Wildlife*, 191 F.3d at 1163; *Natural Resources Defense Council v. USEPA* (9th Cir. 1992) 966 F.2d 1292, 1296.) In these amendments, enacted as part of the Water Quality Act of 1987, Congress distinguished between industrial and municipal storm water discharges. With respect to industrial storm water discharges, Congress provided that NPDES permits "shall meet all applicable provisions of this section and section 1311 [requiring the USEPA to establish effluent limitations under specific timetables]." (CWA § 402(p)(3)(A), 33 U.S.C. § 1342(p)(3)(A); see also *Defenders of Wildlife*, 191 F.3d at 1163-64.)

In 1990, USEPA adopted regulations specifying what activities were considered "industrial" and thus required discharges of storm water associated with those activities to obtain coverage under NPDES permits. (55 Fed. Reg. 47,990 (1990); 40 C.F.R. § 122.26(b)(14).) Construction activities, deemed a subset of the industrial activities category, must also be regulated by an NPDES permit. (40 C.F.R. § 122.26(b)(14)(x)). In 1999, USEPA issued regulations for "Phase II" of storm water regulation, which required most small construction sites (1-5 acres) to be regulated under the NPDES program. (64 Fed. Reg. 68,722; 40 C.F.R. § 122.26(b)(15)(i).)

2. Court Decisions on Public Participation

Two recent federal court opinions have vacated USEPA rules that denied meaningful public review of NPDES permit conditions. On January 14, 2003, the Ninth Circuit Court of Appeals held that certain aspects of USEPA's Phase II regulations governing MS4s were invalid primarily because the general permit did not contain express requirements for public participation. (*Environmental Defense Center v. USEPA* (9th Cir. 2003) 344 F.3d 832.) Specifically, the court determined that applications for general permit coverage (including the Notice of Intent (NOI) and Storm Water Management Program (SWMP)) must be made available to the public, the applications must be reviewed and determined to meet the applicable standard by the permitting authority before coverage commences, and there must be a process to accommodate public hearings. (*Id.* at 852-54.) Similarly, on February 28, 2005, the Second Circuit Court of Appeals held that the USEPA's confined animal feeding operation (CAFO) rule violated the CWA because it allowed dischargers to write their own nutrient management plans without public review. (*Waterkeeper Alliance v. USEPA* (2d Cir. 2005) 399 F.3d 486.) Although neither decision involved the issuance of construction storm water permits, the State Water Board's Office of Chief Counsel has recommended that the new General Permit address the courts' rulings where feasible¹.

¹ In *Texas Independent Producers and Royalty Owners Assn. v. USEPA* (7th Cir. 2005) 410 F.3d 964, the Seventh Circuit Court of Appeals held that the USEPA's construction general permit was not required to provide the public with the opportunity for a public hearing on the Notice of Intent or Storm Water Pollution Prevention Plan. The Seventh Circuit briefly discussed why it agreed with the Ninth Circuit's dissent in *Environmental Defense Center*, but generally did not discuss the substantive holdings in *Environmental Defense Center* and *Waterkeeper Alliance*, because neither court addressed the initial question of whether the plaintiffs had standing to challenge the permits at issue. However, notwithstanding the Seventh Circuit's decision, it is not binding or controlling on the State Water Board because California is located within the Ninth Circuit.

The CWA and the USEPA's regulations provide states with the discretion to formulate permit terms, including specifying best management practices (BMPs), to achieve strict compliance with federal technology-based and water quality-based standards. (*Natural Resources Defense Council v. USEPA* (9th Cir. 1992) 966 F.2d 1292, 1308.) Accordingly, this General Permit has developed specific BMPs as well as numeric action levels (NALs) and numeric effluent limitations (NELs) in order to achieve these minimum federal standards. In addition, the General Permit requires a SWPPP and REAP (another dynamic, site-specific plan) to be developed but has removed all language requiring the discharger to implement these plans – instead, the discharger is required to comply with specific requirements. By requiring the dischargers to implement these specific BMPs, NALs, and NELs, this General Permit ensures that the dischargers do not “write their own permits.” As a result this General Permit does not require each discharger's SWPPP and REAP to be reviewed and approved by the Regional Water Boards.

This General Permit also requires dischargers to electronically file all permit-related compliance documents. These documents include, but are not limited to, NOIs, SWPPPs, annual reports, Notice of Terminations (NOTs), and numeric action level (NAL) exceedance reports. Electronically submitted compliance information is immediately available to the public, as well as the Regional Water Quality Control Board (Regional Water Board) offices, via the Internet. In addition, this General Permit enables public review and hearings on permit applications when appropriate. Under this General Permit, the public clearly has a meaningful opportunity to participate in the permitting process.

C. Blue Ribbon Panel of Experts and Feasibility of Numeric Effluent Limitations

In 2005 and 2006, the State Water Board convened an expert panel (panel) to address the feasibility of numeric effluent limitations (NELs) in California's storm water permits. Specifically, the panel was asked to address:

“Is it technically feasible to establish numeric effluent limitations, or some other quantifiable limit, for inclusion in storm water permits? How would such limitations or criteria be established, and what information and data would be required?”

“The answers should address industrial general permits, construction general permits, and area-wide municipal permits. The answers should also address both technology-based limitations or criteria and water quality-based limitations or criteria. In evaluating establishment of any objective criteria, the panel should address all of the following:

The ability of the State Water Board to establish appropriate objective limitations or criteria;

How compliance determinations would be made;

The ability of dischargers and inspectors to monitor for compliance; and

The technical and financial ability of dischargers to comply with the limitations or criteria.”

Through a series of public participation processes (State Water Board meetings, State Water Board workshops, and the solicitation of written comments), a number of water quality, public process and overall program effectiveness problems were identified. Some of these problems are addressed through this General Permit.

D. Summary of Panel Findings on Construction Activities

The panel's final report can be downloaded and viewed through links at www.waterboards.ca.gov or by clicking [here](#)².

The panel made the following observations:

"Limited field studies indicate that traditional erosion and sediment controls are highly variable in performance, resulting in highly variable turbidity levels in the site discharge."

"Site-to-site variability in runoff turbidity from undeveloped sites can also be quite large in many areas of California, particularly in more arid regions with less natural vegetative cover and steep slopes."

"Active treatment technologies involving the use of polymers with relatively large storage systems now exist that can provide much more consistent and very low discharge turbidity. However, these technologies have as yet only been applied to larger construction sites, generally five acres or greater. Furthermore, toxicity has been observed at some locations, although at the vast majority of sites, toxicity has not occurred. There is also the potential for an accidental large release of such chemicals with their use."

"To date most of the construction permits have focused on TSS and turbidity, but have not addressed other, potentially significant pollutants such as phosphorus and an assortment of chemicals used at construction sites."

"Currently, there is no required training or certification program for contractors, preparers of soil erosion and sediment control Storm Water Pollution Prevention Plans, or field inspectors."

"The quality of storm water discharges from construction sites that effectively employ BMPs likely varies due to site conditions such as climate, soil, and topography."

"The States of Oregon and Washington have recently adopted similar concepts to the Action Levels described earlier."

In addition, the panel made the following conclusions:

"It is the consensus of the Panel that active treatment technologies make Numeric Limits technically feasible for pollutants commonly associated with storm water discharges from construction sites (e.g. TSS and turbidity) for larger construction sites. Technical practicalities and cost-effectiveness may make these technologies less feasible for smaller sites, including small drainages within a larger site, as these technologies have seen limited use at small construction sites. If chemical addition is not permitted, then Numeric Limits are not likely feasible."

"The Board should consider Numeric Limits or Action Levels for other pollutants of relevance to construction sites, but in particular pH. It is of particular concern where fresh concrete or wash water from cement mixers/equipment is exposed to storm water."

"The Board should consider the phased implementation of Numeric Limits and Action Levels, commensurate with the capacity of the dischargers and support industry to respond."

² http://www.waterboards.ca.gov/stormwtr/docs/numeric/swpanel_final_report.pdf

E. How the Panel's Findings are Used in this General Permit

The State Water Board carefully considered the findings of the panel and related public comments. The State Water Board also reviewed and considered the comments regarding statewide storm water policy and the reissuance of the Industrial General Permit. From the input received the State Water Board identified some permit and program performance gaps that are addressed in this General Permit. The Summary of Significant Changes (below) in this General Permit are a direct result of this process.

F. Summary of Significant Changes in This General Permit

The State Water Board has significant changes to Order 99-08-DWQ. This General Permit differs from Order 99-08-DWQ in the following significant ways:

Rainfall Erosivity Waiver: this General Permit includes the option allowing a small construction site (>1 and <5 acres) to self-certify if the rainfall erosivity value (R value) for their site's given location and time frame compute to be less than or equal to 5.

Technology-Based Numeric Action Levels: this General Permit includes NALs for pH and turbidity.

Technology-Based Numeric Effluent Limitations: this General Permit contains daily average NELs for pH during any construction phase where there is a high risk of pH discharge and daily average NELs turbidity for all discharges in Risk Level 3. The daily average NEL for turbidity is set at 500 NTU to represent the minimum technology that sites need to employ (to meet the traditional Best Available Technology Economically Achievable (BAT)/ Best Conventional Pollutant Control Technology (BCT) standard) and the traditional, numeric receiving water limitations for turbidity.

Risk-Based Permitting Approach: this General Permit establishes three levels of risk possible for a construction site. Risk is calculated in two parts: 1) Project Sediment Risk, and 2) Receiving Water Risk.

Minimum Requirements Specified: this General Permit imposes more minimum BMPs and requirements that were previously only required as elements of the SWPPP or were suggested by guidance.

Project Site Soil Characteristics Monitoring and Reporting: this General Permit provides the option for dischargers to monitor and report the soil characteristics at their project location. The primary purpose of this requirement is to provide better risk determination and eventually better program evaluation.

Effluent Monitoring and Reporting: this General Permit requires effluent monitoring and reporting for pH and turbidity in storm water discharges. The purpose of this monitoring is to determine compliance with the NELs and evaluate whether NALs included in this General Permit are exceeded.

Receiving Water Monitoring and Reporting: this General Permit requires some Risk Level 3 dischargers to monitor receiving waters and conduct bioassessments.

Post-Construction Storm Water Performance Standards: this General Permit specifies runoff reduction requirements for all sites not covered by a Phase I or Phase II MS4 NPDES permit, to avoid, minimize and/or mitigate post-construction storm water runoff impacts.

Rain Event Action Plan: this General Permit requires certain sites to develop and implement a Rain Event Action Plan (REAP) that must be designed to protect all exposed portions of the site within 48 hours prior to any likely precipitation event.

Annual Reporting: this General Permit requires all projects that are enrolled for more than one continuous three-month period to submit information and annually certify that their site is in compliance

with these requirements. The primary purpose of this requirement is to provide information needed for overall program evaluation and public information.

Certification/Training Requirements for Key Project Personnel: this General Permit requires that key personnel (e.g., SWPPP preparers, inspectors, etc.) have specific training or certifications to ensure their level of knowledge and skills are adequate to ensure their ability to design and evaluate project specifications that will comply with General Permit requirements.

Linear Underground/Overhead Projects: this General Permit includes requirements for all Linear Underground/Overhead Projects (LUPs).

II. RATIONALE

A. General Permit Approach

A general permit for construction activities is an appropriate permitting approach for the following reasons:

1. A general permit is an efficient method to establish the essential regulatory requirements for a broad range of construction activities under differing site conditions;
2. A general permit is the most efficient method to handle the large number of construction storm water permit applications;
3. The application process for coverage under a general permit is far less onerous than that for individual permit and hence more cost effective;
4. A general permit is consistent with USEPA's four-tier permitting strategy, the purpose of which is to use the flexibility provided by the CWA in designing a workable and efficient permitting system; and
5. A general permit is designed to provide coverage for a group of related facilities or operations of a specific industry type or group of industries. It is appropriate when the discharge characteristics are sufficiently similar, and a standard set of permit requirements can effectively provide environmental protection and comply with water quality standards for discharges. In most cases, the general permit will provide sufficient and appropriate management requirements to protect the quality of receiving waters from discharges of storm water from construction sites.

There may be instances where a general permit is not appropriate for a specific construction project. A Regional Water Board may require any discharger otherwise covered under the General Permit to apply for and obtain an Individual Permit or apply for coverage under a more specific General Permit. The Regional Water Board must determine that this General Permit does not provide adequate assurance that water quality will be protected, or that there is a site-specific reason why an individual permit should be required.

B. Construction Activities Covered

1. Construction activity subject to this General Permit:

Any construction or demolition activity, including, but not limited to, clearing, grading, grubbing, or excavation, or any other activity that results in a land disturbance of equal to or greater than one acre.

Construction activity that results in land surface disturbances of less than one acre if the construction activity is part of a larger common plan of development or sale of one or more acres of disturbed land surface.

Construction activity related to residential, commercial, or industrial development on lands currently used for agriculture including, but not limited to, the construction of buildings related to agriculture that are considered industrial pursuant to USEPA regulations, such as dairy barns or food processing facilities.

Construction activity associated with LUPs including, but not limited to, those activities necessary for the installation of underground and overhead linear facilities (e.g., conduits, substructures, pipelines, towers, poles, cables, wires, connectors, switching, regulating and transforming equipment and associated ancillary facilities) and include, but are not limited to, underground utility mark-out, potholing, concrete

and asphalt cutting and removal, trenching, excavation, boring and drilling, access road and pole/tower pad and cable/wire pull station, substation construction, substructure installation, construction of tower footings and/or foundations, pole and tower installations, pipeline installations, welding, concrete and/or pavement repair or replacement, and stockpile/borrow locations.

Discharges of sediment from construction activities associated with oil and gas exploration, production, processing, or treatment operations or transmission facilities.³

Storm water discharges from dredge spoil placement that occur outside of U.S. Army Corps of Engineers jurisdiction⁴ (upland sites) and that disturb one or more acres of land surface from construction activity are covered by this General Permit. Construction projects that intend to disturb one or more acres of land within the jurisdictional boundaries of a CWA § 404 permit should contact the appropriate Regional Water Board to determine whether this permit applies to the project.

2. Linear Underground/Overhead Projects (LUPs) subject to this General Permit:

Underground/overhead facilities typically constructed as LUPs include, but are not limited to, any conveyance, pipe, or pipeline for the transportation of any gaseous, liquid (including water, wastewater for domestic municipal services), liquescent, or slurry substance; any cable line or wire for the transmission of electrical energy; any cable line or wire for communications (e.g., telephone, telegraph, radio or television messages); and associated ancillary facilities. Construction activities associated with LUPs include, but are not limited to, those activities necessary for the installation of underground and overhead linear facilities (e.g., conduits, substructures, pipelines, towers, poles, cables, wires, connectors, switching, regulating and transforming equipment and associated ancillary facilities) and include, but are not limited to, underground utility mark-out, potholing, concrete and asphalt cutting and removal, trenching, excavation, boring and drilling, access road and pole/tower pad and cable/wire pull station, substation construction, substructure installation, construction of tower footings and/or foundations, pole and tower installations, pipeline installations, welding, concrete and/or pavement repair or replacement, and stockpile/borrow locations.

Water Quality Order 2003-0007-DWQ regulated construction activities associated with small LUPs that resulted in land disturbances greater than one acre, but less than five acres. These projects were considered non-traditional construction projects. Attachment A of this Order now regulates all construction activities from LUPs resulting in land disturbances greater than one acre.

3. Common Plan of Development or Sale

USEPA regulations include the term “common plan of development or sale” to ensure that acreage within a common project does not artificially escape the permit requirements because construction activities are phased, split among smaller parcels, or completed by different owners/developers. In the absence of an exact definition of “common plan of development or sale,” the State Water Board is required to exercise its regulatory discretion in providing a common sense interpretation of the term as it applies to construction projects and permit coverage. An overbroad interpretation of the term would render meaningless the clear “one acre” federal permitting threshold and would potentially trigger permitting of

³ Pursuant to the Ninth Circuit Court of Appeals’ decision in *NRDC v. EPA* (9th Cir. 2008) 526 F.3d 591, and subsequent denial of the USEPA’s petition for reconsideration in November 2008, oil and gas construction activities discharging storm water contaminated only with sediment are no longer exempt from the NPDES program.

⁴ A construction site that includes a dredge and/or fill discharge to any water of the United States (e.g., wetland, channel, pond, or marine water) requires a CWA Section 404 permit from the U.S. Army Corps of Engineers and a CWA Section 401 Water Quality Certification from the Regional Water Board or State Water Board.

almost any construction activity that occurs within an area that had previously received area-wide utility or road improvements.

Construction projects generally receive grading and/or building permits (Local Permits) from local authorities prior to initiating construction activity. These Local Permits spell out the scope of the project, the parcels involved, the type of construction approved, etc. Referring to the Local Permit helps define "common plan of development or sale." In cases such as tract home development, a Local Permit will include all phases of the construction project including rough grading, utility and road installation, and vertical construction. All construction activities approved in the Local Permit are part of the common plan and must remain under the General Permit until construction is completed. For custom home construction, Local Permits typically only approve vertical construction as the rough grading, utilities, and road improvements were already independently completed under the a previous Local Permit. In the case of a custom home site, the homeowner must submit plans and obtain a distinct and separate Local Permit from the local authority in order to proceed. It is not the intent of the State Water Board to require permitting for an individual homeowner building a custom home on a private lot of less than one acre if it is subject to a separate Local Permit. Similarly, the installation of a swimming pool, deck, or landscaping that disturbs less than one acre that was not part of any previous Local Permit are not required to be permitted.

The following are several examples of construction activity of less than one acre that would require permit coverage:

- a. A landowner receives a building permit(s) to build tract homes on a 100-acre site split into 200 one-third acre parcels, (the remaining acreage consists of streets and parkways) which are sold to individual homeowners as they are completed. The landowner completes and sells all the parcels except for two. Although the remaining two parcels combined are less than one acre, the landowner must continue permit coverage for the two parcels.
- b. One of the parcels discussed above is sold to another owner who intends to complete the construction as already approved in the Local Permit. The new landowner must file Permit Registration Documents (PRDs) to complete the construction even if the new landowner is required to obtain a separate Local Permit.
- c. Landowner in (1) above purchases 50 additional one half-acre parcels adjacent to the original 200-acre project. The landowner seeks a Local Permit (or amendment to existing Local permit) to build on 20 parcels while leaving the remaining 30 parcels for future development. The landowner must amend PRDs to include the 20 parcels 14 days prior to commencement of construction activity on those parcels.

C. Construction Activities Not Covered

1. Traditional Construction Projects Not Covered

This General Permit does not apply to the following construction activity:

- a. Routine maintenance to maintain original line and grade, hydraulic capacity, or original purpose of the facility.
- b. Disturbances to land surfaces solely related to agricultural operations such as disking, harrowing, terracing and leveling, and soil preparation.

- c. Discharges of storm water from areas on tribal lands; construction on tribal lands is regulated by a federal permit.
- d. Discharges of storm water within the Lake Tahoe Hydrologic Unit. The Lahontan Regional Water Board has adopted its own permit to regulate storm water discharges from construction activity in the Lake Tahoe Hydrologic Unit (Regional Water Board 6SLT). Owners of construction projects in this watershed must apply for the Lahontan Regional Water Board permit rather than the statewide Construction General Permit. Construction projects within the Lahontan region must also comply with the Lahontan Region Project Guideline for Erosion Control (R6T-2005-0007 Section), which can be found at http://www.waterboards.ca.gov/lahontan/Adopted_Orders/2005/r6t_2005_0007.pdf
- e. Construction activity that disturbs less than one acre of land surface, unless part of a larger common plan of development or the sale of one or more acres of disturbed land surface.
- f. Construction activity covered by an individual NPDES Permit for storm water discharges.
- g. Landfill construction activity that is subject to the Industrial General Permit.
- h. Construction activity that discharges to Combined Sewer Systems.
- i. Conveyances that discharge storm water runoff combined with municipal sewage.
- j. Discharges of storm water identified in CWA § 402(l)(2), 33 U.S.C. § 1342(l)(2).

2. Linear Projects Not Covered

- a. LUP construction activity does not include linear routine maintenance projects. Routine maintenance projects are projects associated with operations and maintenance activities that are conducted on existing lines and facilities and within existing right-of-way, easements, franchise agreements, or other legally binding agreements of the discharger. Routine maintenance projects include, but are not limited to projects that are conducted to:
 - i. Maintain the original purpose of the facility or hydraulic capacity.
 - ii. Update existing lines⁵ and facilities to comply with applicable codes, standards, and regulations regardless if such projects result in increased capacity.
 - iii. Repairing leaks.

Routine maintenance does not include construction of new⁶ lines or facilities resulting from compliance with applicable codes, standards, and regulations.

Routine maintenance projects do not include those areas of maintenance projects that are outside of an existing right-of-way, franchise, easements, or agreements. When a project must secure new areas,

⁵Update existing lines includes replacing existing lines with new materials or pipes.

⁶New lines are those that are not associated with existing facilities and are not part of a project to update or replace existing lines.

those areas may be subject to this General Permit based on the area of disturbed land outside the original right-of-way, easement, or agreement.

- b. LUP construction activity does not include field activities associated with the planning and design of a project (e.g., activities associated with route selection).
- c. Tie-ins conducted immediately adjacent to “energized” or “pressurized” facilities by the discharger are not considered construction activities where all other LUP construction activities associated with the tie-in are covered by an NOI and SWPPP of a third party or municipal agency.

3. EPA’s Small Construction Rainfall Erosivity Waiver

EPA’s Storm Water Phase II Final Rule provides the option for a Small Construction Rainfall Erosivity Waiver. This waiver applies to small construction sites between 1 and 5 acres, and allows permitting authorities to waive those sites that do not have adverse water quality impacts.

Dischargers eligible for this waiver are exempt from Construction General Permit Coverage. In order to obtain the waiver, the discharger must certify to the State Water Board that small construction activity will occur only when the rainfall erosivity factor is less than 5 (“R” in the Revised Universal Soil Loss Equation). The period of construction activity begins at initial earth disturbance and ends with final stabilization. Where vegetation will be used for final stabilization, the date of installation of a practice that provides interim non-vegetative stabilization can be used for the end of the construction period. The operator must agree (as a condition waiver eligibility) to periodically inspect and properly maintain the area until the criteria for final stabilization as defined in the General Permit have been met. If use of this interim stabilization eligibility condition was relied on to qualify for the waiver, signature on the waiver with a certification statement constitutes acceptance of and commitment to complete the final stabilization process. The discharger must submit a waiver certification to the State Board prior to commencing construction activities.

USEPA funded a cooperative agreement with Texas A&M University to develop an online rainfall erosivity calculator. Dischargers can access the calculator from EPA’s website at: www.epa.gov/npdes/stormwater/cgp. Use of the calculator allows the discharger to determine potential eligibility for the rainfall erosivity waiver. It may also be useful in determining the time periods during which construction activity could be waived from permit coverage.

D. Obtaining and Terminating Permit Coverage

The Legally Responsible Person (LRP) must obtain coverage under this General Permit, except in two limited circumstances. First, where the construction of pipelines, utility lines, fiber-optic cables, or other linear underground/overhead projects will occur across several properties, the utility company, municipality, or other public or private company or agency that owns or operates the linear underground/overhead project is responsible for obtaining coverage under the General Permit. Second, where there is a lease of a mineral estate (oil, gas, geothermal, aggregate, precious metals, and/or industrial metals), the lessee is responsible for obtaining coverage under the General Permit. To obtain coverage, the LRP or other entity described above must file Permit Registration Documents (PRDs) prior to the commencement of construction activity. Failure to obtain coverage under this General Permit for storm water discharges to waters of the United States is a violation of the CWA and the California Water Code.

To obtain coverage under this General Permit, LRPs must electronically file the PRDs, which include a Notice of Intent (NOI), Storm Water Pollution Prevention Plan (SWPPP), and other documents required by this General Permit, and mail the appropriate permit fee to the State Water Board. It is expected that as the storm water program develops, the Regional Water Boards may issue General Permits or

Individual Permits that contain more specific permit provisions. When this occurs, this General Permit will no longer regulate those dischargers that obtain coverage under Individual Permits.

Any information provided to the Regional Water Board shall comply with the Homeland Security Act and any other federal law that concerns security in the United States; any information that does not comply should not be submitted.

The application requirements of the General Permit establish a mechanism to clearly identify the responsible parties, locations, and scope of operations of dischargers covered by the General Permit and to document the discharger's knowledge of the General Permit's requirements.

This General Permit provides a grandfathering exception to existing dischargers subject to Water Quality Order No. 99-08-DWQ. Construction projects covered under Water Quality Order No. 99-08-DWQ shall obtain permit coverage at Risk Level 1. LUP projects covered under Water Quality Order No. 2003-0007-DWQ shall obtain permit coverage at LUP Type 1. The Regional Water Boards have the authority to require Risk Determination to be performed on projects currently covered under Water Quality Order No. 99-08-DWQ and 2003-0007-DWQ where they deem necessary.

LRPs must file a Notice of Termination (NOT) with the Regional Water Board when construction is complete and final stabilization has been reached or ownership has been transferred. The discharger must certify that all State and local requirements have been met in accordance with this General Permit. In order for construction to be found complete, the discharger must install post-construction storm water management measures and establish a long-term maintenance plan. This requirement is intended to ensure that the post-construction conditions at the project site do not cause or contribute to direct or indirect water quality impacts (i.e., pollution and/or hydromodification) upstream and downstream. Specifically, the discharger must demonstrate compliance with the post-construction standards set forth in this General Permit (Section XIII). The discharger is responsible for all compliance issues including all annual fees until the NOT has been filed and approved by the local Regional Water Board.

E. Discharge Prohibitions

This General Permit authorizes the discharge of storm water to surface waters from construction activities that result in the disturbance of one or more acres of land, provided that the discharger satisfies all permit conditions set forth in the Order. This General Permit prohibits the discharge of pollutants other than storm water and non-storm water discharges authorized by this General Permit or another NPDES permit. This General Permit also prohibits all discharges which contain a hazardous substance in excess of reportable quantities established in 40 C.F.R. §§ 117.3 and 302.4, unless a separate NPDES Permit has been issued to regulate those discharges. In addition, this General Permit incorporates discharge prohibitions contained in water quality control plans, as implemented by the nine Regional Water Boards. Discharges to Areas of Special Biological Significance (ASBS) are prohibited unless covered by an exception that the State Water Board has approved.

Non-storm water discharges include a wide variety of sources, including improper dumping, spills, or leakage from storage tanks or transfer areas. Non-storm water discharges may contribute significant pollutant loads to receiving waters. Measures to control spills, leakage, and dumping, and to prevent illicit connections during construction must be addressed through structural as well as non-structural BMPs. The State Water Board recognizes, however, that certain non-storm water discharges may be necessary for the completion of construction projects. Authorized non-storm water discharges may include those from de-chlorinated potable water sources such as: fire hydrant flushing, irrigation of vegetative erosion control measures, pipe flushing and testing, water to control dust, uncontaminated ground water dewatering, and other discharges not subject to a separate general NPDES permit adopted by a region. Therefore this General Permit authorizes such discharges provided they meet the following conditions.

These authorized non-storm water discharges must:

1. be infeasible to eliminate;
2. comply with BMPs as described in the SWPPP;
3. filter or treat, using appropriate technology, all dewatering discharges from sedimentation basins;
4. meet the NELs and NALs for pH and turbidity; and
5. not cause or contribute to a violation of water quality standards.

Additionally, authorized non-storm water discharges must not be used to clean up failed or inadequate construction or post-construction BMPs designed to keep materials onsite. Authorized non-storm water dewatering discharges may require a permit because some Regional Water Boards have adopted General Permits for dewatering discharges.

This General Permit prohibits the discharge of storm water that causes or threatens to cause pollution, contamination, or nuisance.

F. Effluent Standards for All Types of Discharges

1. Technology-Based Effluent Limitations

Permits for storm water discharges associated with construction activity must meet all applicable provisions of Sections 301 and 402 of the CWA. These provisions require controls of pollutant discharges that utilize best available technology economically achievable (BAT) for toxic pollutants and non conventional pollutants and best conventional pollutant control technology (BCT) for conventional pollutants. Additionally, these provisions require controls of pollutant discharges to reduce pollutants and any more stringent controls necessary to meet water quality standards. The USEPA has already established such limitations, known as effluent limitation guidelines (ELGs), for some industrial categories. This is not the case with construction discharges. In instances where there are no ELGs the permit writer is to use best professional judgment (BPJ) to establish requirements that the discharger must meet using BAT/BCT technology. This General Permit contains both narrative effluent limitations and new numeric effluent limitations for pH and turbidity, set using the best professional judgment (BPJ) equivalent to BAT and BCT (respectively).

BAT/BCT technologies not only include passive systems such as conventional runoff and sediment control, but also treatment systems such as coagulation/flocculation using sand filtration, when appropriate. Such technologies allow for effective treatment of soil particles less 0.02 mm (medium silt) in diameter. The discharger must install structural controls, as necessary, such as erosion and sediment controls that meet BAT and BCT to achieve compliance with water quality standards. The narrative effluent limitations constitute compliance with the requirements of the CWA.

The numeric effluent limitations for pH and turbidity are based upon BPJ, which authorizes the State Water Board to issue a permit containing "such conditions as the Administrator determines are necessary to carry out the provisions of this Chapter" (CWA § 402(a)(1), 33 U.S.C. § 1342(a)(1).) Because the USEPA has not yet issued an effluent limit guideline for storm water, the State Water Board must use BPJ to consider the appropriate technology for the category or class of point sources, based upon all available information and any unique factors relating to the sources. In addition, the permitting authority must consider a number of factors including the cost of achieving effluent reductions in relation to the effluent reduction benefits, the age of the equipment and facilities, the processes employed and any required process changes, engineering aspects of the control technologies, non-water quality environmental impacts (including energy requirements), and other such other factors as the State Water Board deems appropriate (CWA 304(b)(1)(B)).

Because the permit is an NPDES permit, there is no legal requirement to address the factors set forth in Water Code sections 13241 and 13263, unless the permit is more stringent than what federal law requires. (See *City of Burbank v. State Water Resources Control Bd.* (2005) 35 Cal.4th 613, 618, 627.) None of the requirements in this permit are more stringent than the minimum federal requirements, which include technology-based requirements achieving BAT/BCT and strict compliance with water quality standards. The inclusion of numeric effluent limitations (NELs) in the permit do not cause the permit to be more stringent than current federal law. NELs and best management practices are simply two different methods of achieving the same federal requirement: strict compliance with state water quality standards. Federal law authorizes both narrative and numeric effluent limitations to meet state water quality standards. The use of NELs to achieve compliance with water quality standards is not a more stringent requirement than the use of BMPs. (State Water Board Order No. WQ 2006-0012 (*Boeing*)). Accordingly, the State Water Board does not need to take into account the factors in Water Code sections 13241 and 13263.

The State Water Board has concluded that the establishment of BAT/BCT will not create or aggravate other environmental problems through increases in air pollution, solid waste generation, or energy consumption. While there may be a slight increase in non-water quality impacts due to the implementation of additional monitoring or the construction of additional BMPs, these impacts will be negligible in comparison with the construction activities taking place on site and would be justified by the water quality benefits associated with compliance.

Considerations related to the processes employed and the changes necessitated by the adoption of the BAT/BCT effluent limits have been assessed throughout the stakeholder process (e.g., the Blue Ribbon Panel and the March 2007 preliminary draft) and are discussed in detail in Section I.C of this Fact Sheet. The following sections set forth the engineering aspects of the control technologies and the rationale for the determination of the numeric effluents for pH and turbidity.

In consideration of the costs for the establishment of BAT and BCT limits for pH and turbidity, existing requirements for the control of storm water pollution from construction sites have been established by USEPA and the previous Construction General Permit (State Water Board Order No. 99-08-DWQ) issued by the State Water Board. The General Permit establishes one, consistent set of performance standards for all levels and types of discharges (i.e., risk, linear utility, and ATS). The only difference is that for each level or type of discharge there may be more or less specific effluent limitations (e.g., the addition of numeric effluent limitations for turbidity applies to level/type 3 discharges). And the numeric effluent limitations themselves represent a minimum technology standard. In other words, the additional numeric effluent limitations, compared to the existing permit's narrative effluent limitations, do not increase compliance requirements; rather, they simply represent a point where one can quantitatively measure compliance with the lower end of the range of required technologies. Therefore, the compliance costs associated with the BAT/BCT numeric effluent limitations in this permit only differ by the costs required to measure compliance with the NELs when compared to the baseline compliance costs to comply with the limitations already established through EPA regulations and the existing Construction General Permit.

The State Water Board estimates these measurement costs to be approximately \$1000 per construction site for the duration of the project. This represents the estimated cost of purchasing (or renting) monitoring equipment, in this case a turbidimeter (~\$600) and a pH meter (~\$400). In some cases the costs may be higher or lower. Costs could be lower if the discharger chooses to design and implement the project in a manner where effluent monitoring is likely to be avoided (e.g., no exposure during wet weather seasons, no discharge due to containment, etc.). Costs could be more if the project is subject to many effluent monitoring events or if the discharger exceeds NALs and/or NELs, resulting in additional monitoring requirements.

i. **pH NEL**

Given the potential contaminants, the minimum standard method for control of pH in runoff requires the use of preventive measures such as avoiding concrete pours during rainy weather, covering concrete and directing flow away from fresh concrete if a pour occurs during rain, covering scrap drywall and stucco

materials when stored outside and potentially exposed to rain, and other housekeeping measures. If necessary, pH-impaired storm water from construction sites can be treated in a filter or settling pond or basin, with additional natural or chemical treatment required to meet pH limits set forth in this permit. The basin or pond acts as a collection point and holds storm water for a sufficient period for the contaminants to be settled out, either naturally or artificially, and allows any additional treatment to take place. The State Water Board considers these techniques to be equivalent to BCT. In determining the pH concentration limit for discharges, the State Water Board used BPJ to set these limitations.

The chosen limits were established by calculating three standard deviations above and below the mean pH of runoff from highway construction sites⁷ in California. Proper implementation of BMPs should result in discharges that are within the range of 6.0 to 9.0 pH Units.

ii. *Turbidity NEL*

The Turbidity NEL of 500 NTU is a technology-based numeric effluent limitation and was developed using three different analyses aimed at finding the appropriate threshold to set the technology-based limit to ensure environmental protection, effluent quality and cost-effectiveness. The analyses fell into three, main types: (1) an ecoregion-specific dataset developed by Simon et. al. (2004)⁸; (2) Statewide Regional Water Quality Control Board enforcement data; and (3) published, peer-reviewed studies and reports on in-situ performance of best management practices in terms of erosion and sediment control on active construction sites.

A 1:3 relationship between turbidity (expressed as NTU) and suspended sediment concentration (expressed as mg/L) is assumed based on a review of suspended sediment and turbidity data from three gages used in the USGS National Water Quality Assessment Program:

USGS 11074000 SANTA ANA R BL PRADO DAM CA
 USGS 11447650 SACRAMENTO R A FREEPORT CA
 USGS 11303500 SAN JOAQUIN R NR VERNALIS CA

The turbidity NEL represents a feasible and cost effective performance standard that is demonstrated to be achievable. Although data has been collected to demonstrate that lower effluent levels may be achievable at some sites, staff cannot conclude at this time that a lower NEL is achievable within all the ecoregions of the state. The NEL represents staff determination that the NEL is the most practicable based on available data. The turbidity NEL represents a bridge between the narrative effluent limitations and receiving water limitations. The NEL limit may be considered an interim performance standard as additional data becomes available for evaluation during the next permit cycle. To support this NEL, State Water Board staff analyzed construction site discharge information (monitoring data, estimates) and receiving water monitoring information.

Since the turbidity NEL represents an appropriate threshold level expected at a site, compliance with this value does not necessarily represent compliance with either the narrative effluent limitations (as enforced through the BAT/BCT standard) or the receiving water limitations. In the San Diego region, some inland surface waters have a receiving water objective for turbidity equal to 20 NTU. Obviously a discharge up to, but not exceeding, the turbidity NEL of 500 NTU may still cause or contribute to the exceedance of the 20 NTU standard. Most of the waters of the State are protected by turbidity objectives based on background conditions.

⁷ Caltrans Construction Sites Runoff Characterization Study, 2002. Available at: <http://www.dot.ca.gov/hq/env/stormwater/pdf/CTSW-RT-02-055.pdf>.

⁸ Simon, A., W.D. Dickerson, and A. Heins. 2004. Suspended-sediment transport rates at the 1.5-year recurrence interval for ecoregions of the United States: transport conditions at the bankfull and effective discharge. *Geomorphology* 58: pp. 243-262.

Table 1 - Regional Water Board Basin Plans, Water Quality Objectives for Turbidity

REGIONAL WATER BOARD	WQ Objective	Background/Natural Turbidity	Maximum Increase
1 Based	on background	All levels	20%
2 Based	on background	> 50 NTU	10%
3 Based	on background	0-50 JTU 50-100 JTU > 100 JTU	20% 10 NTU 10%
4 Based	on background	0-50 NTU > 50 NTU	20% 10%
5 Based	on background	0-5 NTU 5-50 NTU 50-100 NTU >100 NTU	1 NTU 20% 10 NTU 10%
6 Based	on background	All levels	10%
7 Based	on background	N/A N/A	
8 Based	on background	0-50 NTU 50-100 NTU >100 NTU	20% 10 NTU 10%
9 Inland	Surface Waters, 20 NTU All others, based on background	 0-50 NTU 50-100 NTU >100 NTU	 20% 10 NTU 10%

Table 2 shows the suspended sediment concentrations at the 1.5 year flow recurrence interval for the 12 ecoregions in California from Simon et. al (2004).

Table 2 - Results of Ecoregion Analysis

Ecoregion	Percent of California Land Area	Median Suspended Sediment Concentration (mg/L)
1 9.1		874
4 0.2		120
5 8.8		35.6
6 20.7		1530
7 7.7		122
8 3.0		47.4
9 9.4		284
13 5.2		143
14 21.7		5150
78 8.1		581
80 2.4		199
81 3.7		503
Area-weighted average		1633

If a 1:3 relationship between turbidity and suspended sediment is assumed, the median turbidity is 544 NTU.

The following table is composed of turbidity readings measured in NTUs from administrative civil liberty (ACL) actions for construction sites from 2003 - 2009. This data was derived from the complete listing of construction-related ACLs for the six year period. All ACLs were reviewed and those that included turbidimeter readings at the point of storm water discharge were selected for this dataset.

Table 3 – ACL Sampling Data taken by Regional Water Board Staff

WDID# Regi	on	Discharger	Turbidity (NTU)
5S34C331884	5S Brad	shaw Interceptor Section 6B	1800
5S05C325110	5S Bridal	wood Subdivision	1670
5S48C336297	5S Cheye	ne at Browns Valley	1629
5R32C314271	5R Gri	zzly Ranch Construction	1400
6A090406008	6T	El Dorado County Department of Transportation, Angora Creek	97.4
5S03C346861	5S	TML Development, LLC	1600
6A31C325917	6T	Northstar Village	See Subdata Set

Subdata Set - Turbidity for point of storm water runoff discharge at Northstar Village

Date Turbi	dity (NTU)	Location
10/5/2006	900	Middle Martis Creek
11/2/2006	190	Middle Martis Creek
01/04/2007	36	West Fork, West Martis Creek
02/08/2007	180	Middle Martis Creek
02/09/2007	130	Middle Martis Creek
02/09/2007	290	Middle Martis Creek
02/09/2007	100	West Fork, West Martis Creek
02/10/2007	28	Middle Martis Creek
02/10/2007	23	Middle Martis Creek
02/10/2007	32	Middle Martis Creek
02/10/2007	12	Middle Martis Creek
02/10/2007	60	West Fork, West Martis Creek
02/10/2007	34	West Fork, West Martis Creek

A 95% confidence interval for mean turbidity in an ACL order was constructed. The data set used was a small sample size, so the 500 NTU (the value derived as the NEL for this General Permit) needed to be verified as a possible population mean. In this case, the population refers to a hypothetical population of turbidity measurements of which our sample of 20 represents. A t-distribution was assumed due to the small sample size:

Mean: 512.23 NTU
Standard Deviation: 686.85
Margin of Error: 321.45
Confidence Interval: 190.78 NTU (Low)
833.68 NTU (High)

Based on a constructed 95% confidence interval, an ACL order turbidity measurement will be between 190.78 – 833.68 NTU. 500 NTU falls within this range. Using the same data set, a small-sample hypothesis test was also performed to test if the ACL turbidity data set contains enough information to cast doubt on choosing a 500 NTU as a mean. 500 NTU was again chosen due to its proposed use as an acceptable NEL value. The test was carried out using a 95% confidence interval. Results indicated that the ACL turbidity data set *does not* contain significant sample evidence to reject the claim of 500 NTU as an acceptable mean for the ACL turbidity population.

There are not many published, peer-reviewed studies and reports on in-situ performance of best management practices in terms of erosion and sediment control on active construction sites. The most often cited study is a report titled, “Improving the Cost Effectiveness of Highway Construction Site Erosion and Pollution Control” (Horner, Guedry, and Kortenof 1990, <http://www.wsdot.wa.gov/Research/Reports/200/200.1.htm>). In a comment letter summarizing this report sent to the State Water Board, the primary author, Dr. Horner, states:

“The most effective erosion control product was wood fiber mulch applied at two different rates along with a bonding agent and grass seed in sufficient time before the tests to achieve germination. Plots treated in this way reduced influent turbidity by more than 97 percent and discharged effluent exhibiting mean and maximum turbidity values of 21 and 73 NTU, respectively. Some other mulch and blanket materials performed nearly as well. These tests demonstrated the control ability of widely available BMPs over a very broad range of erosion potential.”

Other technologies studied in this report produced effluent quality at or near 100 NTU. It is the BPJ of the State Water Board staff that erosion control, while preferred, is not always an option on construction sites and that technology performance in a controlled study showing effluent quality directly leaving a BMP is always easier and cheaper to control than effluent being discharged from the project (edge of property, etc.). As a result, it is the BPJ of the State Water Board staff that it is not cost effective or feasible, at this time, for all risk level and type 3 sites in California to achieve effluent discharges with turbidity values that are less than 100 NTU.

To summarize, the analysis showed that: (1) results of the Simon et. al dataset reveals turbidity values in background receiving water in California’s ecoregions range from 16 NTU to 1716 NTU (with a mean of 544 NTU); (2) based on a constructed 95% confidence interval, construction sites will be subject to administrative civil liability (ACL) when their turbidity measurement falls between 190.78 – 833.68 NTU; and (3) sites with highly controlled discharges employing and maintaining good erosion control practices can discharge effluent from the BMP with turbidity values less than 100 NTU. Therefore, the appropriate threshold to set the technology-based limit to ensure environmental protection, effluent quality, and cost-effectiveness ranges from 100 NTU to over 1700 NTU. To keep this parameter and the costs of compliance as low as possible, State Water Board staff has determined, using its BPJ, that it is most cost effective to set the numeric effluent limitation for turbidity at 500 NTU.

a. Compliance Storm Event

In response to public comments on the last draft and the recommendations of the expert panel, this General Permit contains “compliance storm event” exceptions from the technology-based NELs. The rationale is that technology-based requirements are developed assuming a certain design storm (defined as the storm producing a rainfall amount for a specified BMPs capacity). Compliance thresholds are needed for storm events above and beyond the design storms assumed to determine the technology-based NELs. For Risk Level 3 project sites applicable to NELs, this General Permit establishes a compliance storm event as the equivalent rainfall in a 5-year, 24-hour storm. This compliance storm was

chosen due to its relative infrequent occurrence and the fact that the runoff volume associated with it is not as large as a 10-year, 24-hour storm event. The discharger shall determine this value using Western Regional Climate Center Precipitation Frequency Maps⁹ for 5-year 24-hour storm events in Northern and Southern California (note that these are expressed in tenths of inches – divide by 10 to get inches).

b. TMDLs and Waste Load Allocations

Dischargers located within the watershed of a CWA § 303(d) impaired water body, for which a TMDL for sediment has been adopted by the Regional Water Board or USEPA, must comply with the approved TMDL if it identifies “construction activity” or land disturbance as a source of sediment. If it does, the TMDL should include a specific waste load allocation for this activity/source. The discharger, in this case, may be required by a separate Regional Water Board order to implement additional BMPs, conduct additional monitoring activities, and/or comply with an applicable waste load allocation and implementation schedule. If a specific waste load allocation has been established that would apply to a specific discharge, the Regional Water Board may adopt an order requiring specific implementation actions necessary to meet that allocation. In the instance where an approved TMDL has specified a general waste load allocation to construction storm water discharges, but no specific requirements for construction sites have been identified in the TMDL, dischargers must consult with the state TMDL authority¹⁰ to confirm that adherence to a SWPPP that meets the requirements of the General Permit will be consistent with the approved TMDL.

2. Determining Compliance with Effluent Standards

a. Technology-Based Numeric Action Levels (NALs)

This General Permit contains technology-based NALs for pH and turbidity, and requirements for effluent monitoring at all Risk level 2 & 3, and LUP Type 2 & 3 sites. Numeric action levels are essentially numeric benchmark values for certain parameters that, if exceeded in effluent sampling, trigger the discharger to take actions. Exceedance of an NAL does not itself constitute a violation of the General Permit. If the discharger fails to take the corrective action required by the General Permit, though, that may constitute a violation.

The primary purpose of NALs is to assist dischargers in evaluating the effectiveness of their on-site measures. Construction sites need to employ many different systems that must work together to achieve compliance with the permit's requirements. The NALs chosen should indicate whether the systems are working as intended.

Another purpose of NALs is to provide information regarding construction activities and water quality impacts. This data will provide the State and Regional Water Boards and the rest of the storm water community with more information about levels and types of pollutants present in runoff and how effective the dischargers BMPs are at reducing pollutants in effluent. The State Water Board also hopes to learn more about the linkage between effluent and receiving water quality. In addition, these requirements will provide information on the mechanics needed to establish compliance monitoring programs at construction sites in future permit deliberations.

i. pH

⁹ <http://www.wrcc.dri.edu/pcpnfreq/nca5y24.gif> & <http://www.wrcc.dri.edu/pcpnfreq/sca5y24.gif> .

¹⁰ <http://www.waterboards.ca.gov/tmdl/tmdl.html>.

The chosen limits were established by calculating one standard deviation above and below the mean pH of runoff from highway construction sites¹¹ in California. Proper implementation of BMPs should result in discharges that are within the range of 6.5 to 8.5 pH Units.

The Caltrans study included 33 highway construction sites throughout California over a period of four years, which included 120 storm events. All of these sites had BMPs in place that would be generally implemented at all types of construction sites in California.

ii. *Turbidity*

BPJ was used to develop an NAL that can be used as a learning tool to help dischargers improve their site controls, and to provide meaningful information on the effectiveness of storm water controls. A statewide turbidity NAL has been set at 250 NTU.

G. Receiving Water Limitations

Construction-related activities that cause or contribute to an exceedance of water quality standards must be addressed. The dynamic nature of construction activity gives the discharger the ability to quickly identify and monitor the source of the exceedances. This is because when storm water mobilizes sediment, it provides visual cues as to where corrective actions should take place and how effective they are once implemented.

This General Permit requires that storm water discharges and authorized non-storm water discharges must not contain pollutants that cause or contribute to an exceedance of any applicable water quality objective or water quality standards. The monitoring requirements in this General Permit for sampling and analysis procedures will help determine whether BMPs installed and maintained are preventing pollutants in discharges from the construction site that may cause or contribute to an exceedance of water quality standards.

Water quality standards consist of designated beneficial uses of surface waters and the adoption of ambient criteria necessary to protect those uses. When adopted by the State Water Board or a Regional Water Board, the ambient criteria are termed "water quality objectives." If storm water runoff from construction sites contains pollutants, there is a risk that those pollutants could enter surface waters and cause or contribute to an exceedance of water quality standards. For that reason, dischargers should be aware of the applicable water quality standards in their receiving waters. (The best method to ensure compliance with receiving water limitations is to implement BMPs that prevent pollutants from contact with storm water or from leaving the construction site in runoff.)

In California, water quality standards are published in the Basin Plans adopted by each Regional Water Board, the California Toxics Rule (CTR), the National Toxics Rule (NTR), and the Ocean Plan.

Dischargers can determine the applicable water quality standards by contacting Regional Water Board staff or by consulting one of the following sources. The actual Basin Plans that contain the water quality standards can be viewed at the website of the appropriate Regional Water Board.

(<http://www.waterboards.ca.gov/regions.html>), the State Water Board site for statewide plans (<http://www.waterboards.ca.gov/plnspols/index.html>), or the USEPA regulations for the NTR and CTR (40 C.F.R. §§ 131.36-38). Basin Plans and statewide plans are also available by mail from the appropriate Regional Water Board or the State Water Board. The USEPA regulations are available at <http://www.epa.gov/>. Additional information concerning water quality standards can be accessed through http://www.waterboards.ca.gov/stormwtr/gen_const.html.

¹¹ Caltrans Construction Sites Runoff Characterization Study, 2002. Available at: <http://www.dot.ca.gov/hq/env/stormwater/pdf/CTSW-RT-02-055.pdf>.

H. Training Qualifications and Requirements

The Blue Ribbon Panel (BRP) made the following observation about the lack of industry-specific training requirements:

“Currently, there is no required training or certification program for contractors, preparers of soil erosion and sediment control Storm Water Pollution Prevention Plans, or field inspectors.”

Order 99-08-DWQ required that all dischargers train their employees on how to comply with the permit, but it did not specify a curriculum or certification program. This has resulted in inconsistent implementation by all affected parties - the dischargers, the local governments where the construction activity occurs, and the regulators required to enforce 99-08-DWQ. This General Permit requires Qualified SWPPP Developers and practitioners to obtain appropriate training, and makes this curriculum mandatory two years after adoption, to allow time for course completion. The State and Regional Water Board are working with many stakeholders to develop the curriculum and mechanisms needed to develop and deliver the courses.

To ensure that the preparation, implementation, and oversight of the SWPPP is sufficient for effective pollution prevention, the Qualified SWPPP Developer and Qualified SWPPP Practitioners responsible for creating, revising, overseeing, and implementing the SWPPP must attend a State Water Board-sponsored or approved Qualified SWPPP Developer and Qualified SWPPP Practitioner training course.

I. Sampling, Monitoring, Reporting and Record Keeping

1. Traditional Construction Monitoring Requirements

This General Permit requires visual monitoring at all sites, and effluent water quality at all Risk Level 2 & 3 sites. It requires receiving water monitoring at some Risk Level 3 sites. All sites are required to submit annual reports, which contain various types of information, depending on the site characteristics and events. A summary of the monitoring and reporting requirements is found in Table 4.

Table 4 - Required Monitoring Elements for Risk Levels

	Visual	Non-visible Pollutant	Effluent	Receiving Water
Risk Level 1			where applicable	not required
Risk Level 2	three types required for all Risk Levels: non-storm water, pre-rain and post-rain	As needed for all Risk Levels (see below)	pH, turbidity	not required
Risk Level 3			(if NEL exceeded) pH, turbidity and SSC	(if NEL exceeded) pH, turbidity and SSC. Bioassessment for sites 30 acres or larger.

a. Visual

All dischargers are required to conduct quarterly, non-storm water visual inspections. For these inspections, the discharger must visually observe each drainage area for the presence of (or indications of prior) unauthorized and authorized non-storm water discharges and their sources. For storm-related inspections, dischargers must visually observe storm water discharges at all discharge locations within two business days after a qualifying event. For this requirement, a qualifying rain event is one producing precipitation of ½ inch or more of discharge. Dischargers must conduct a post-storm event inspection to

(1) identify whether BMPs were adequately designed, implemented, and effective, and (2) identify any additional BMPs necessary and revise the SWPPP accordingly. Dischargers must maintain on-site records of all visual observations, personnel performing the observations, observation dates, weather conditions, locations observed, and corrective actions taken in response to the observations.

b. Non-Visible Pollutant Monitoring

This General Permit requires that all dischargers develop a sampling and analysis strategy for monitoring pollutants that are not visually detectable in storm water. Monitoring for non-visible pollutants must be required at any construction site when the exposure of construction materials occurs and where a discharge can cause or contribute to an exceedance of a water quality objective.

Of significant concern for construction discharges are the pollutants found in materials used in large quantities at construction sites throughout California and exposed throughout the rainy season, such as cement, flyash, and other recycled materials or by-products of combustion. The water quality standards that apply to these materials will depend on their composition. Some of the more common storm water pollutants from construction activity are not CTR pollutants. Examples of non-visible pollutants include glyphosate (herbicides), diazinon and chlorpyrifos (pesticides), nutrients (fertilizers), and molybdenum (lubricants). The use of diazinon and chlorpyrifos is a common practice among landscaping professionals and may trigger sampling and analysis requirements if these materials come into contact with storm water. High pH values from cement and gypsum, high pH and SSC from wash waters, and chemical/fecal contamination from portable toilets, also are not CTR pollutants. Although some of these constituents do have numeric water quality objectives in individual Basin Plans, many do not and are subject only to narrative water quality standards (i.e. not causing toxicity). Dischargers are encouraged to discuss these issues with Regional Water Board staff and other storm water quality professionals.

The most effective way to avoid the sampling and analysis requirements, and to ensure permit compliance, is to avoid the exposure of construction materials to precipitation and storm water runoff. Materials that are not exposed do not have the potential to enter storm water runoff, and therefore receiving waters sampling is not required. Preventing contact between storm water and construction materials is one of the most important BMPs at any construction site.

Preventing or eliminating the exposure of pollutants at construction sites is not always possible. Some materials, such as soil amendments, are designed to be used in a manner that will result in exposure to storm water. In these cases, it is important to make sure that these materials are applied according to the manufacturer's instructions and at a time when they are unlikely to be washed away. Other construction materials can be exposed when storage, waste disposal or the application of the material is done in a manner not protective of water quality. For these situations, sampling is required unless there is capture and containment of all storm water that has been exposed. In cases where construction materials may be exposed to storm water, but the storm water is contained and is not allowed to run off the site, sampling will only be required when inspections show that the containment failed or is breached, resulting in potential exposure or discharge to receiving waters.

The discharger must develop a list of potential pollutants based on a review of potential sources, which will include construction materials soil amendments, soil treatments, and historic contamination at the site. The discharger must review existing environmental and real estate documentation to determine the potential for pollutants that could be present on the construction site as a result of past land use activities.

Good sources of information on previously existing pollution and past land uses include:

- i. Environmental Assessments;
- ii. Initial Studies;
- iii. Phase 1 Assessments prepared for property transfers; and

- iv. Environmental Impact Reports or Environmental Impact Statements prepared under the requirements of the National Environmental Policy Act or the California Environmental Quality Act.

In some instances, the results of soil chemical analyses may be available and can provide additional information on potential contamination.

The potential pollutant list must include all non-visible pollutants that are known or should be known to occur on the construction site including, but not limited to, materials that:

- i. are being used in construction activities;
- ii. are stored on the construction site;
- iii. were spilled during construction operations and not cleaned up;
- iv. were stored (or used) in a manner that created the potential for a release of the materials during past land use activities;
- v. were spilled during previous land use activities and not cleaned up; or
- vi. were applied to the soil as part of past land use activities.

C. Effluent Monitoring

Federal regulations¹² require effluent monitoring for discharges subject to NALs and NELs. Subsequently, all Risk Level 2 and 3 dischargers must perform sampling and analysis of effluent discharges to characterize discharges associated with construction activity from the entire area disturbed by the project. Dischargers must collect samples of stored or contained storm water that is discharged subsequent to a storm event producing precipitation of ½ inch or more at the time of discharge.

Table 5 - Storm Water Effluent Monitoring Requirements by Risk Level

	Frequency	Effluent Monitoring (Section E, below)
Risk Level 1	when applicable	non-visible pollutant parameters (if applicable)
Risk Level 2	Minimum of 3 samples per day during qualifying rain event characterizing discharges associated with construction activity from the entire project disturbed area.	pH, turbidity, and non-visible pollutant parameters (if applicable)
Risk Level 3	Minimum of 3 samples per day during qualifying rain event characterizing discharges associated with construction activity from the entire project disturbed area.	If NEL exceeded: pH, turbidity and suspended sediment concentration (SSC)., Plus non-visible pollutant parameters if applicable

Risk Level 1 dischargers must analyze samples for:

¹² 40 C.F.R. § 122.44.

- i. any parameters indicating the presence of pollutants identified in the pollutant source assessment required in Attachment C contained in the General Permit.

Risk Level 2 dischargers must analyze samples for:

- i. pH and turbidity;
- ii. any parameters indicating the presence of pollutants identified in the pollutant source assessment required in Attachment D contained in the General Permit, and
- iii. any additional parameters for which monitoring is required by the Regional Water Board.

Risk Level 3 dischargers must analyze samples for:

- i. pH, turbidity and SSC;
- ii. any parameters indicating the presence of pollutants identified in the pollutant source assessment required in Attachment E contained in the General Permit, and
- iii. any additional parameters for which monitoring is required by the Regional Water Board.

2. Linear Monitoring and Sampling Requirements

Attachment A, establishes minimum monitoring and reporting requirements for all LUPs. It establishes different monitoring requirements depending on project complexity and risk to water quality. The monitoring requirements for Type 1 LUPs are less than Type 2 & 3 projects because Type 1 projects have a lower potential to impact water quality.

A discharger shall prepare a monitoring program prior to the start of construction and immediately implement the program at the start of construction for LUPs. The monitoring program must be implemented at the appropriate level to protect water quality at all times throughout the life of the project.

a. Type 1 LUP Monitoring Requirements

A discharger must conduct daily visual inspections of Type 1 LUPs during working hours while construction activities are occurring. Inspections are to be conducted by qualified personnel and can be conducted in conjunction with other daily activities. Inspections will be conducted to ensure the BMPs are adequate, maintained, and in place at the end of the construction day. The discharger will revise the SWPPP, as appropriate, based on the results of the daily inspections. Inspections can be discontinued in non-active construction areas where soil disturbing activities have been completed and final stabilization has been achieved (e.g., trench has been paved, substructures have been installed, and successful final vegetative cover or other stabilization criteria have been met).

A discharger shall implement the monitoring program for inspecting Type 1 LUPs. This program requires temporary and permanent stabilization BMPs after active construction is completed. Inspection activities will continue until adequate permanent stabilization has been established and will continue in areas where re-vegetation is chosen until minimum vegetative coverage has been established. Photographs shall be taken during site inspections and submitted to the State Water Board.

b. Type 2 & 3 LUP Monitoring Requirements

A discharger must conduct daily visual inspections of Type 2 & 3 LUPs during working hours while construction activities are occurring. Inspections are to be conducted by qualified personnel and can be in conjunction with other daily activities.

All dischargers of Type 2 & 3 LUPs are required to conduct inspections by qualified personnel of the construction site during normal working hours prior to all anticipated storm events and after actual storm events. During extended storm events, the discharger shall conduct inspections during normal working hours for each 24-hour period. Inspections can be discontinued in non-active construction areas where soil disturbing activities have been completed and final stabilization has been achieved (e.g., trench has been paved, substructures installed, and successful vegetative cover or other stabilization criteria have been met).

The goals of these inspections are (1) to identify areas contributing to a storm water discharge; (2) to evaluate whether measures to reduce pollutant loadings identified in the SWPPP are adequate and properly installed and functioning in accordance with the terms of the General Permit; and (3) to determine whether additional control practices or corrective maintenance activities are needed. Equipment, materials, and workers must be available for rapid response to failures and emergencies. All corrective maintenance to BMPs shall be performed as soon as possible, depending upon worker safety.

All dischargers shall develop and implement a monitoring program for inspecting Type 2 & 3 LUPs that require temporary and permanent stabilization BMPs after active construction is completed. Inspections will be conducted to ensure the BMPs are adequate and maintained. Inspection activities will continue until adequate permanent stabilization has been established and will continue in areas where revegetation is chosen until minimum vegetative coverage has been established.

A log of inspections conducted before, during, and after the storm events must be maintained in the SWPPP. The log will provide the date and time of the inspection and who conducted the inspection. Photographs must be taken during site inspections and submitted to the State Water Board.

c. Sampling Requirements for all LUP Project Types

LUPs are also subject to sampling and analysis requirements for visible pollutants (i.e., sedimentation/siltation, turbidity) and for non-visible pollutants.

Sampling for visible pollutants is required for Type 2 & 3 LUPs.

Non-visible pollutant monitoring is required for pollutants associated with construction sites and activities that (1) are not visually detectable in storm water discharges, and (2) are known or should be known to occur on the construction site, and (3) could cause or contribute to an exceedance of water quality objectives in the receiving waters. Sample collection for non-visible pollutants must only be required (1) during a storm event when pollutants associated with construction activities may be discharged with storm water runoff due to a spill, or in the event there was a breach, malfunction, failure, and/or leak of any BMP, and (2) when the discharger has failed to adequately clean the area of material and pollutants. Failure to implement appropriate BMPs will trigger the same sampling requirements as those required for a breach, malfunction and/or leak, or when the discharger has failed to implement appropriate BMPs prior to the next storm event.

Additional monitoring parameters may be required by the Regional Water Boards.

It is not anticipated that many LUPs will be required to collect samples for pollutants not visually detected in runoff due to the nature and character of the construction site and activities as previously described in this fact sheet. Most LUPs are constructed in urban areas with public access (e.g., existing roadways, road shoulders, parking areas, etc.). This raises a concern regarding the potential contribution of pollutants from vehicle use and/or from normal activities of the public (e.g., vehicle washing, landscape fertilization, pest spraying, etc.) in runoff from the project site. Since the dischargers are not the land

owners of the project area and are not able to control the presence of these pollutants in the storm water that runs through their projects, it is not the intent of this General Permit to require dischargers to sample for these pollutants. This General Permit does not require the discharger to sample for these types of pollutants except where the discharger has brought materials onsite that contain these pollutants and when a condition (e.g., breach, failure, etc.) described above occurs.

3. Receiving Water Monitoring

In order to ensure that receiving water limitations are met, discharges subject to numeric effluent limitations (i.e., Risk Level 3, LUP Type 3, and ATS with direct discharges into receiving waters) must also monitor the downstream receiving water(s) for turbidity, SSC, and pH (if applicable) when an NEL is exceeded.

a. Bioassessment Monitoring

This General Permit requires a bioassessment of receiving waters for dischargers of Risk Level 3 or LUP Type 3 construction projects equal to or larger than 30 acres with direct discharges into receiving waters. Benthic macroinvertebrate samples will be taken upstream and downstream of the site's discharge point in the receiving water. Bioassessments measure the quality of the stream by analyzing the aquatic life present. Higher levels of appropriate aquatic species tend to indicate a healthy stream; whereas low levels of organisms can indicate stream degradation. Active construction sites have the potential to discharge large amounts of sediment and pollutants into receiving waters. Requiring a bioassessment for large project sites, with the most potential to impact water quality, provides a snapshot of the health of the receiving water prior to initiation of construction activities. This snapshot can be used in comparison to the health of the receiving water after construction has commenced.

Each ecoregion (biologically and geographically related area) in the State has a specific yearly peak time where stream biota is in a stable and abundant state. This time of year is called an Index Period. The bioassessment requirements in this General Permit, requires benthic macroinvertebrate sampling within a sites index period. The State Water Board has developed a map designating index periods for the ecoregions in the State (see State Water Board Website).

This General Permit requires the bioassessment methods to be in accordance with the Surface Water Ambient Monitoring Program (SWAMP) in order to provide data consistency within the state as well as generate useable biological stream data.

Table 6 - Receiving Water Monitoring Requirements

	Receiving Water Monitoring Parameters
Risk Level 1 /LUP Type 1	not required
Risk Level 2 / LUP Type 2	not required
Risk Level 3 / LUP Type 3	If NEL exceeded: pH (if applicable), turbidity, and SSC. Bioassessment for sites 30 acres or larger.

4. Reporting Requirements

a. NEL Violation Report

All Risk Level 3 and LUP Type 3 dischargers must electronically submit all storm event sampling results to the State and Regional Water Boards, via SMARTS, no later than 5 days after the conclusion of the storm event. The purpose of the electronic filing of the NEL Violation Report is to 1) inform stakeholder agencies and organizations and the general public, and 2) notify the State and Regional Water Boards of

the exceedance so that they can determine whether any follow-up (e.g., inspection, enforcement, etc.) is necessary to bring the site into compliance.

In the event that an applicable NEL has been exceeded during a storm event equal to or larger than the Compliance Storm Event, Risk level 3/LUP Type 3 dischargers shall report the on-site rain gauge reading and nearby governmental rain gauge readings for verification. Specifically, the NEL Exceedance Report is required to contain:

- the analytical method(s), method reporting unit(s), and method detection limit(s) of each analytical parameter (analytical results that are less than the method detection limit are to be reported as "less than the method detection limit or <MDL");
- the date, place, and time of sampling;
- any visual observation (inspections);
- any measurements, including precipitation; and
- a description of the current BMPs associated with the effluent sample that exceeded the NEL and any proposed corrective actions taken.

b. NAL Exceedance Report

All Risk Level 3 and LUP Type 3 dischargers must electronically submit all storm event sampling results to the State and Regional Water Boards, via the electronic data system, no later than 5 days after the conclusion of the storm event. In the event that any effluent sample exceeds an applicable NAL, all Risk Level 2 and LUP Type 2 dischargers must electronically submit all storm event sampling results to the State and Regional Water Boards no later than 10 days after the conclusion of the storm event. The Regional Water Boards have the authority to require the submittal of an NAL Exceedance Report.

Specifically, the NAL Exceedance Report is required to contain:

- the analytical method(s), method reporting unit(s), and method detection limit(s) of each analytical parameter (analytical results that are less than the method detection limit are to be reported as "less than the method detection limit or <MDL");
- the date, place, and time of sampling;
- any visual observation (inspections);
- any measurements, including precipitation; and
- a description of the current BMPs associated with the effluent sample that exceeded the NAL and any proposed corrective actions taken.

c. Annual Report

All dischargers must prepare and electronically submit an annual report no later than September 1 of each year using the Storm water Multi-Application Reporting and Tracking System (SMARTS). The Annual Report must include a summary and evaluation of all sampling and analysis results, original laboratory reports, chain of custody forms, a summary of all corrective actions taken during the compliance year, and identification of any compliance activities or corrective actions that were not implemented.

5. Record Keeping

According to 40 C.F.R. Parts 122.21(p) and 122.41(j), the discharger is required to retain paper or electronic copies of all records required by this General Permit for a period of at least three years from the date generated or the date submitted to the State Water Board or Regional Water Boards. A discharger must retain records for a period beyond three years as directed by Regional Water Board.

J. Risk Determination

1. Traditional Projects

a. Overall Risk Determination

There are two major requirements related to site planning and risk determination in this General Permit. The project's overall risk is broken up into two elements – (1) project sediment risk (the relative amount of sediment that can be discharged, given the project and location details) and (2) receiving water risk (the risk sediment discharges pose to the receiving waters).

Project Sediment Risk:

Project Sediment Risk is determined by multiplying the R, K, and LS factors from the Revised Universal Soil Loss Equation (RUSLE) to obtain an estimate of project-related bare ground soil loss expressed in tons/acre. The RUSLE equation is as follows:

$$A = (R)(K)(LS)(C)(P)$$

Where: A = the rate of sheet and rill erosion

R = rainfall-runoff erosivity factor

K = soil erodibility factor

LS = length-slope factor

C = cover factor (erosion controls)

P = management operations and support practices (sediment controls)

The C and P factors are given values of 1.0 to simulate bare ground conditions.

There is a map option and a manual calculation option for determining soil loss. For the map option, the R factor for the project is calculated using the online calculator at <http://cfpub.epa.gov/npdes/stormwater/LEW/lewCalculator.cfm>. The product of K and LS are shown on Figure 1. To determine soil loss in tons per acre, the discharger multiplies the R factor times the value for K times LS from the map.

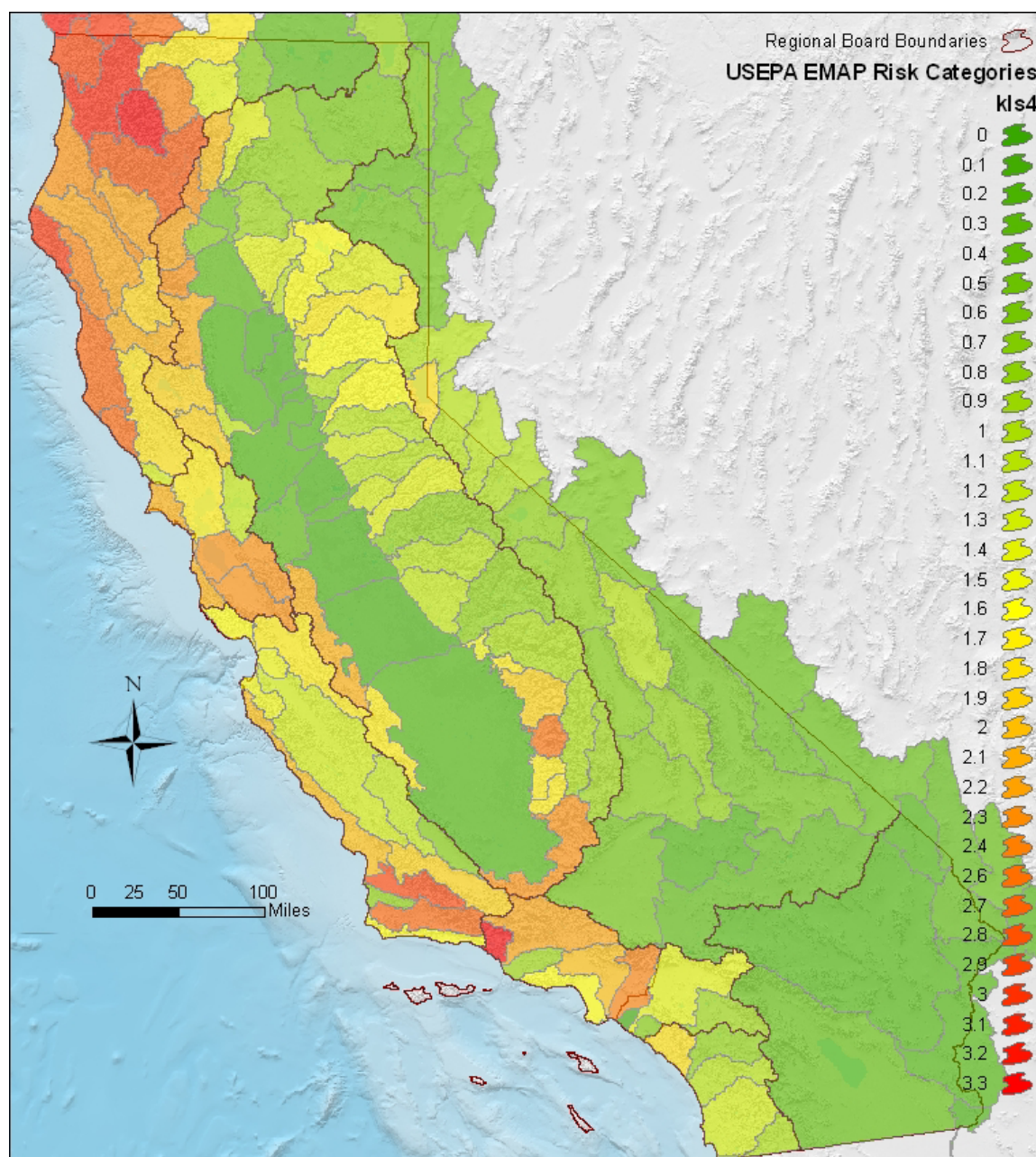

State Water Resources Control Board, January 15, 2008

Figure 1 -Statewide Map of K * LS

For the manual calculation option, the R factor for the project is calculated using the online calculator at <http://cfpub.epa.gov/npdes/stormwater/LEW/lewCalculator.cfm>. The K and LS factors are determined using Appendix 1.

Soil loss of less than 15 tons/acre is considered **low** sediment risk.

Soil loss between 15 and 75 tons/acre is **medium** sediment risk.

Soil loss over 75 tons/acre is considered **high** sediment risk.

The soil loss values and risk categories were obtained from mean and standard deviation RKLS values from the USEPA EMAP program. High risk is the mean RKLS value plus two standard deviations. Low risk is the mean RKLS value minus two standard deviations.

Receiving Water Risk:

Receiving water risk is based on whether a project drains to a sediment-sensitive waterbody. A sediment-sensitive waterbody is either

- on the most recent 303d list for waterbodies impaired for sediment;
- has a USEPA-approved Total Maximum Daily Load implementation plan for sediment; **or**
- has the beneficial uses of COLD, SPAWN, and MIGRATORY.

A project that meets at least one of the three criteria has a high receiving water risk. A list of sediment-sensitive waterbodies will be posted on the State Water Board's website. It is anticipated that an interactive map of sediment sensitive water bodies in California will be available in the future.

The Risk Levels have been altered by eliminating the possibility of a Risk Level 4, and expanding the constraints for Risk Levels 1, 2, and 3. Therefore, projects with high receiving water risk and high sediment risk will be considered a Risk Level 3 risk to water quality.

In response to public comments, the Risk Level requirements have also been changed such that Risk Level 1 projects will be subject to minimum BMP and visual monitoring requirements, Risk Level 2 projects will be subject to NALs and some additional monitoring requirements, and Risk Level 3 projects will be subject to NELs, and more rigorous monitoring requirements such as receiving water monitoring and in some cases bioassessment.

Table 7 - Combined Risk Level Matrix

Combined Risk Level Matrix			
Receiving Water Risk		Sediment Risk	
		Low Medium	High
	Low	Level 1	Level 2
High	Level 2		Level 3

b. Effluent Standards

All dischargers are subject to the narrative effluent limitations specified in the General Permit. The narrative effluent limitations require storm water discharges associated with construction activity to meet all applicable provisions of Sections 301 and 402 of the CWA. These provisions require controls of pollutant discharges that utilize BAT and BCT to reduce pollutants and any more stringent controls necessary to meet water quality standards.

Risk Level 2, and 3 dischargers are subject to numeric effluent standards comparable to the project's risk to water quality. Risk Level 2 dischargers that pose a medium risk to water quality are subject to technology-based NALs for pH and turbidity. Risk Level 3 dischargers that pose a high risk to water quality are subject to technology-based NALs and technology-based NELs for pH and turbidity.

C. Good Housekeeping

Proper handling and managing of construction materials can help minimize threats to water quality. The discharger must consider good housekeeping measures for: construction materials, waste management, vehicle storage & maintenance, landscape materials, and potential pollutant sources. Examples include; conducting an inventory of products used, implementing proper storage & containment, and properly cleaning all leaks from equipment and vehicles.

d. Non-Storm Water Management

Non-storm water discharges directly connected to receiving waters or the storm drain system have the potential to negatively impact water quality. The discharger must implement measures to control all non-storm water discharges during construction, and from dewatering activities associated with construction. Examples include; properly washing vehicles in contained areas, cleaning streets, and minimizing irrigation runoff.

e. Erosion Control

The best way to minimize the risk of creating erosion and sedimentation problems during construction is to disturb as little of the land surface as possible by fitting the development to the terrain. When development is tailored to the natural contours of the land, little grading is necessary and, consequently, erosion potential is lower.¹⁴ Other effective erosion control measures include: preserving existing vegetation where feasible, limiting disturbance, and stabilizing and re-vegetating disturbed areas as soon as possible after grading or construction activities. Particular attention must be paid to large, mass-graded sites where the potential for soil exposure to the erosive effects of rainfall and wind is great and where there is potential for significant sediment discharge from the site to surface waters. Until permanent vegetation is established, soil cover is the most cost-effective and expeditious method to protect soil particles from detachment and transport by rainfall. Temporary soil stabilization can be the single most important factor in reducing erosion at construction sites. The discharger is required to consider measures such as: covering disturbed areas with mulch, temporary seeding, soil stabilizers, binders, fiber rolls or blankets, temporary vegetation, and permanent seeding. These erosion control measures are only examples of what should be considered and should not preclude new or innovative approaches currently available or being developed. Erosion control BMPs should be the primary means of preventing storm water contamination, and sediment control techniques should be used to capture any soil that becomes eroded.¹³

Risk Level 3 dischargers pose a higher risk to water quality and are therefore additionally required to ensure that post-construction soil loss is equivalent to or less than the pre-construction levels.

f. Sediment Control

Sediment control BMPs should be the secondary means of preventing storm water contamination. When erosion control techniques are ineffective, sediment control techniques should be used to capture any soil that becomes eroded. The discharger is required to consider perimeter control measures such as: installing silt fences or placing straw wattles below slopes. These sediment control measures are only examples of what should be considered and should not preclude new or innovative approaches currently available or being developed.

Because Risk Level 2 and 3 dischargers pose a higher risk to water quality, additional requirements for the application of sediment controls are imposed on these projects. This General Permit also authorizes the Regional Water Boards to require Risk Level 3 dischargers to implement additional site-specific

¹³ U.S. Environmental Protection Agency. 2007. Developing Your Storm Water Pollution Prevention Plan: A Guide for Construction Sites.

sediment control requirements if the implementation of other erosion or sediment controls are not adequately protecting the receiving waters.

g. Run-on and Runoff Control

Inappropriate management of run-on and runoff can result in excessive physical impacts to receiving waters from sediment and increased flows. The discharger is required to manage all run-on and runoff from a project site. Examples include: installing berms and other temporary run-on and runoff diversions.

Risk Level 1 dischargers with lower risks to impact water quality are not subject to the run-on and runoff control requirements unless an evaluation deems them necessary or visual inspections show that such controls are required.

h. Inspection, Maintenance and Repair

All measures must be periodically inspected, maintained and repaired to ensure that receiving water quality is protected. Frequent inspections coupled with thorough documentation and timely repair is necessary to ensure that all measures are functioning as intended.

i. Rain Event Action Plan (REAP)

A Rain Event Action Plan (REAP) is a written document, specific for each rain event. A REAP should be designed that when implemented it protects all exposed portions of the site within 48 hours of any likely precipitation event forecast of 50% or greater probability.

This General Permit requires Risk Level 2 and 3 dischargers to develop and implement a REAP designed to protect all exposed portions of their sites within 48 hours prior to any likely precipitation event. The REAP requirement is designed to ensure that the discharger has adequate materials, staff, and time to implement erosion and sediment control measures that are intended to reduce the amount of sediment and other pollutants generated from the active site. A REAP must be developed when there is likely a forecast of 50% or greater probability of precipitation in the project area. (The National Oceanic and Atmospheric Administration (NOAA) defines a chance of precipitation as a probability of precipitation of 30% to 50% chance of producing precipitation in the project area.¹⁴ NOAA defines the probability of precipitation (PoP) as the likelihood of occurrence (expressed as a percent) of a measurable amount (0.01 inch or more) of liquid precipitation (or the water equivalent of frozen precipitation) during a specified period of time at any given point in the forecast area.) Forecasts are normally issued for 12-hour time periods. Descriptive terms for uncertainty and aerial coverage are used as follows:

Table 8 -National Oceanic and Atmospheric Administration (NOAA) Definition of Probability of Precipitation (PoP)

PoP	Expressions of Uncertainty	Aerial Coverage
0%	none used	none used
10%	none used	isolated
20%	slight chance	isolated
30-50%	chance	scattered

¹⁴ <http://www.crh.noaa.gov/lot/severe/wxterms.php>.

60-70%	likely	numerous
80-100%	none used	none used

The discharger must obtain the precipitation forecast information from the National Weather Service Forecast Office (<http://www.srh.noaa.gov/>).

2. Linear Projects

a. Linear Risk Determination

LUPs vary in complexity and water quality concerns based on the type of project. This General Permit has varying application requirements based on the project's risk to water quality. Factors that lead to the characterization of the project include location, sediment risk, and receiving water risk.

Based on the location and complexity of a project area or project section area, LUPs are separated into project types. As described below, LUPs have been categorized into three project types.

i. *Type 1 LUPs*

Type 1 LUPs are those construction projects where:

- (1) 70 percent or more of the construction activity occurs on a paved surface and where areas disturbed during construction will be returned to preconstruction conditions or equivalent protection established at the end of the construction activities for the day, or
- (2) greater than 30 percent of construction activities occur within the non-paved shoulders or land immediately adjacent to paved surfaces, or where construction occurs on unpaved improved roads, including their shoulders or land immediately adjacent to them where:

Areas disturbed during construction will be returned to pre-construction conditions or equivalent protection established at the end of the construction activities for the day to minimize the potential for erosion and sediment deposition, and

Areas where established vegetation was disturbed during construction will be stabilized and re-vegetated by the end of project. When required, adequate temporary stabilization Best Management Practices (BMPs) will be installed and maintained until vegetation is established to meet minimum cover requirements established in this General Permit for final stabilization.

Type 1 LUPs typically do not have a high potential to impact storm water quality because (1) these construction activities are not typically conducted during a rain event, (2) these projects are normally constructed over a short period of time¹⁵, minimizing the duration that pollutants could potentially be exposed to rainfall; and (3) disturbed soils such as those from trench excavation are required to be hauled away, backfilled into the trench, and/or covered (e.g., metal plates, pavement, plastic covers over spoil piles) at the end of the construction day.

¹⁵ Short period of time refers to a project duration of weeks to months, but typically less than one year in duration.

Type 1 LUPs are determined during the risk assessment found in Attachment A.1 to be 1) low sediment risk and low receiving water risk; 2) low sediment risk and medium receiving water risk; and 3) medium sediment risk and low receiving water risk.

This General Permit requires the discharger to ensure a SWPPP is developed for these construction activities that is specific to project type, location and characteristics.

ii. **Type 2 LUPs:**

Type 2 projects are determined to have a combination of High, Medium, and Low project sediment risk along with High, Medium, and Low receiving water risk. Like Type 1 projects, Type 2 projects are typically constructed over a short period of time. However, these projects have a higher potential to impact water quality because they:

- (1) typically occur outside the more urban/developed areas;
- (2) have larger areas of soil disturbance that are not closed or restored at the end of the day;
- (3) may have onsite stockpiles of soil, spoil and other materials;
- (4) cross or occur in close proximity to a wide variety of sensitive resources that may include, but are not limited to, steep topography and/or water bodies; and
- (5) have larger areas of disturbed soils that may be exposed for a longer time interval before final stabilization, cleanup and/or reclamation occurs.

This General Permit requires the discharger to develop and implement a SWPPP for these construction activities that are specific for project type, location and characteristics.

iii. **Type 3 LUPs:**

Type 3 projects are determined to have a combination of High and Medium project sediment risk along with High and Medium receiving water risk. Similar to Type 2 projects, Type 3 projects have a higher potential to impact water quality because they:

- (1) typically occur outside of the more urban/developed areas;
- (2) have larger areas of soil disturbance that are not closed or restored at the end of the day;
- (3) may have onsite stockpiles of soil, spoil and other materials;
- (4) cross or occur in close proximity to a wide variety of sensitive resources that may include, but are not limited to, steep topography and/or water bodies; and
- (5) have larger areas of disturbed soils that may be exposed for a longer time interval before final stabilization, cleanup and/or reclamation occurs.

This General Permit requires the discharger to develop and implement a SWPPP for these construction activities that are specific for project type, location, and characteristics.

b. Linear Effluent Standards

All LUPs are subject to the narrative effluent limitations specified in the General Permit.

Type 2 and 3 LUPs are subject to NELs comparable to the project type's risk to water quality. Type 2 projects that pose an intermediate risk to water quality are subject to technology-based NALs for pH and turbidity. Type 3 projects posing a high risk to water quality are subject to technology-based NALs and NELs for pH and turbidity.

c. Linear Good Housekeeping

Improper use and handling of construction materials could potentially cause a threat to water quality. In order to ensure proper site management of these construction materials, all LUP dischargers must comply with a minimum set of Good Housekeeping measures specified in Attachment A of this General Permit.

d. Linear Non-Storm Water Management

In order to ensure control of all non-storm water discharges during construction, all LUP dischargers must comply with the Non-Storm Water Management measures specified in Attachment A of this General Permit.

e. Linear Erosion Control

This General Permit requires all LUP dischargers to implement effective wind erosion control measures, and soil cover for inactive areas. Type 3 LUPs posing a higher risk to water quality are additionally required to ensure the post-construction soil loss is equivalent to or less than the pre-construction levels.

f. Linear Sediment Control

In order to ensure control and containment of all sediment discharges, all LUP dischargers must comply with the general Sediment Control measures specified in Attachment A or this General Permit. Additional requirements for sediment controls are imposed on Type 2 & 3 LUPs due to their higher risk to water quality.

g. Linear Run-on and Runoff Control

Discharges originating outside of a project's perimeter and flowing onto the property can adversely affect the quantity and quality of discharges originating from a project site. In order to ensure proper management of run-on and runoff, all LUPs must comply with the run-on and runoff control measures specified in Attachment A of this General Permit. Due to the lower risk of impacting water quality, Type 1 LUPs are not required to implement run-on and runoff controls unless deemed necessary by the discharger.

h. Linear Inspection, Maintenance and Repair

Proper inspection, maintenance, and repair activities are important to ensure the effectiveness of on-site measures to control water quality. In order to ensure that inspection, maintenance, and repair activities are adequately performed, the all LUP dischargers a re required to comply with the Inspection, Maintenance, and Repair requirements specified in Attachment A of this General Permit.

K. ATS¹⁶ Requirements

There are instances on construction sites where traditional erosion and sediment controls do not effectively control accelerated erosion. Under such circumstances, or under circumstances where storm water discharges leaving the site may cause or contribute to an exceedance of a water quality standard, the use of an Active Treatment System (ATS) may be necessary. Additionally, it may be appropriate to use an ATS when site constraints inhibit the ability to construct a correctly sized sediment basin, when clay and/or highly erosive soils are present, or when the site has very steep or long slope lengths.¹⁷

Although treatment systems have been in use in some form since the mid-1990s, the ATS industry in California is relatively young, and detailed regulatory standards have not yet been developed. Many developers are using these systems to treat storm water discharges from their construction sites. The new ATS requirements set forth in this General Permit are based on those in place for small wastewater treatment systems, ATS regulations from the Central Valley Regional Water Quality Control Board (September 2005 memorandum "2005/2006 Rainy Season – Monitoring Requirements for Storm Water Treatment Systems that Utilize Chemical Additives to Enhance Sedimentation"), the Construction Storm Water Program at the State of Washington's Department of Ecology, as well as recent advances in technology and knowledge of coagulant performance and aquatic safety.

The effective design of an ATS requires a detailed survey and analysis of site conditions. With proper planning, ATS performance can provide exceptional water quality discharge and prevent significant impacts to surface water quality, even under extreme environmental conditions.

These systems can be very effective in reducing the sediment in storm water runoff, but the systems that use additives/polymers to enhance sedimentation also pose a potential risk to water quality (e.g., operational failure, equipment failure, additive/polymer release, etc.). The State Water Board is concerned about the potential acute and chronic impacts that the polymers and other chemical additives may have on fish and aquatic organisms if released in sufficient quantities or concentrations. In addition to anecdotal evidence of polymer releases causing aquatic toxicity in California, the literature supports this concern.¹⁸ For example, cationic polymers have been shown to bind with the negatively charged gills of fish, resulting in mechanical suffocation.¹⁹ Due to the potential toxicity impacts, which may be caused by the release of additives/polymers into receiving waters, this General Permit establishes residual polymer monitoring and toxicity testing requirements have been established in this General Permit for discharges from construction sites that utilize an ATS in order to protect receiving water quality and beneficial uses.

The primary treatment process in an ATS is coagulation/flocculation. ATS's operate on the principle that the added coagulant is bound to suspended sediment, forming floc, which is gravitationally settled in tanks or a basin, or removed by sand filters. A typical installation utilizes an injection pump upstream from the clarifier tank, basin, or sand filters, which is electronically metered to both flow rate and suspended solids level of the influent, assuring a constant dose. The coagulant mixes and reacts with the influent, forming a dense floc. The floc may be removed by gravitational setting in a clarifier tank or basin, or by filtration. Water from the clarifier tank, basin, or sand filters may be routed through cartridge(s) and/or bag filters for final polishing. Vendor-specific systems use various methods of dose control, sediment/floc removal, filtration, etc., that are detailed in project-specific documentation. The

¹⁶ An ATS is a treatment system that employs chemical coagulation, chemical flocculation, or electrocoagulation in order to reduce turbidity caused by fine suspended sediment.

¹⁷ Pitt, R., S. Clark, and D. Lake. 2006. Construction Site Erosion and Sediment Controls: Planning, Design, and Performance. DEStech Publications. Lancaster, PA. 370pp.

¹⁸ Romøen, K., B. Thu, and Ø. Evensen. 2002. Immersion delivery of plasmid DNA II. A study of the potentials of a chitosan based delivery system in rainbow trout (*Oncorhynchus mykiss*) fry. *Journal of Controlled Release* **85**: 215-225.

¹⁹ Bullock, G., V. Blazer, S. Tsukuda, and S. Summerfelt. 2000. Toxicity of acidified chitosan for cultured rainbow trout (*Oncorhynchus mykiss*). *Aquaculture* **185**:273-280.

particular coagulant/flocculant to be used for a given project is determined based on the water chemistry of the site because the coagulants are specific in their reactions with various types of sediments. Appropriate selection of dosage must be carefully matched to the characteristics of each site.

ATS's are operated in two differing modes, either Batch or Flow-Through. Batch treatment can be defined as Pump-Treat-Hold-Test-Release. In Batch treatment, water is held in a basin or tank, and is not discharged until treatment is complete. Batch treatment involves holding or recirculating the treated water in a holding basin or tank(s) until treatment is complete or the basin or storage tank(s) is full. In Flow-Through treatment, water is pumped into the ATS directly from the runoff collection system or storm water holding pond, where it is treated and filtered as it flows through the system, and is then directly discharged. "Flow-Through Treatment" is also referred to as "Continuous Treatment."

1. Effluent Standards

This General Permit establishes NELs for discharges from construction sites that utilize an ATS. These systems lend themselves to NELs for turbidity and pH because of their known reliable treatment. Advanced systems have been in use in some form since the mid-1990s. An ATS is considered reliable, can consistently produce a discharge of less than 10 NTU, and has been used successfully at many sites in several states since 1995 to reduce turbidity to very low levels.²⁰

This General Permit contains "compliance storm event" exceptions from the technology-based NELs for ATS discharges. The rationale is that technology-based requirements are developed assuming a certain design storm. In the case of ATS the industry-standard design storm is 10-year, 24-hour (as stated in Attachment F of this General Permit), so the compliance storm event has been established as the 10-year 24-hour event as well to provide consistency.

2. Training

Operator training is critical to the safe and efficient operation and maintenance of the ATS, and to ensure that all State Water Board monitoring and sampling requirements are met. The General Permit requires that all ATS operators have training specific to using ATS's liquid coagulants.

L. Post-Construction Requirements

Under past practices, new and redevelopment construction activities have resulted in modified natural watershed and stream processes. This is caused by altering the terrain, modifying the vegetation and soil characteristics, introducing impervious surfaces such as pavement and buildings, increasing drainage density through pipes and channels, and altering the condition of stream channels through straightening, deepening, and armoring. These changes result in a drainage system where sediment transport capacity is increased and sediment supply is decreased. A receiving channel's response is dependent on dominant channel materials and its stage of adjustment.

Construction activity can lead to impairment of beneficial uses in two main ways. First, during the actual construction process, storm water discharges can negatively affect the chemical, biological, and physical properties of downstream receiving waters. Due to the disturbance of the landscape, the most likely pollutant is sediment, however pH and other non-visible pollutants are also of great concern. Second, after most construction activities are completed at a construction site, the finished project may result in significant modification of the site's response to precipitation. New development and redevelopment

²⁰ Currier, B., G. Minton, R. Pitt, L. Roesner, K. Schiff, M. Stenstrom, E. Strassler, and E. Strecker. 2006. The Feasibility of Numeric Effluent Limits Applicable to Discharges of Storm Water Associated with Municipal, Industrial and Construction Activities.

projects have almost always resulted in permanent post-construction water quality impacts because more precipitation ends up as runoff and less precipitation is intercepted, evapotranspired, and infiltrated.

General Permit 99-08-DWQ required the SWPPP to include a description of all post-construction BMPs on a site and a maintenance schedule. An effective storm water management strategy must address the full suite of storm events (water quality, channel protection, overbank flood protection, extreme flood protection) (Figure 2).

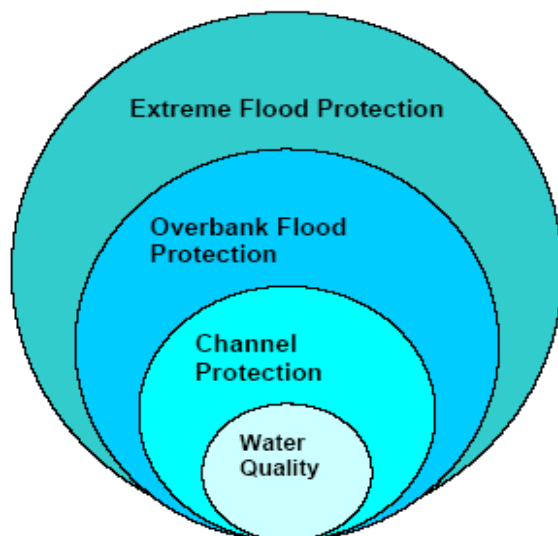

Figure 2 - Suite of Storm Events

The post-construction storm water performance standards in this General Permit specifically address water quality and channel protection events. Overbank flood protection and extreme flood protection events are traditionally dealt with in local drainage and flood protection ordinances. However, measures in this General Permit to address water quality and channel protection also reduce overbank and extreme flooding impacts. This General Permit aims to match post-construction runoff to pre-construction runoff for the 85th percentile storm event, which not only reduces the risk of impact to the receiving water's channel morphology but also provides some protection of water quality.

This General Permit clarifies that its runoff reduction requirements only apply to projects that lie outside of jurisdictions covered by a Standard Urban Storm water Management Plan (SUSMP) (or other more protective) post-construction requirements in either Phase I or Phase II permits.

Figures 3 and 4, below, show the General Permit enrollees (to Order 99-08-DWQ, as of March 10, 2008) overlaid upon a map with SUSMP (or more protective) areas in blue and purple. Areas without blue or purple indicate where the General Permit's runoff reduction requirements would actually apply.

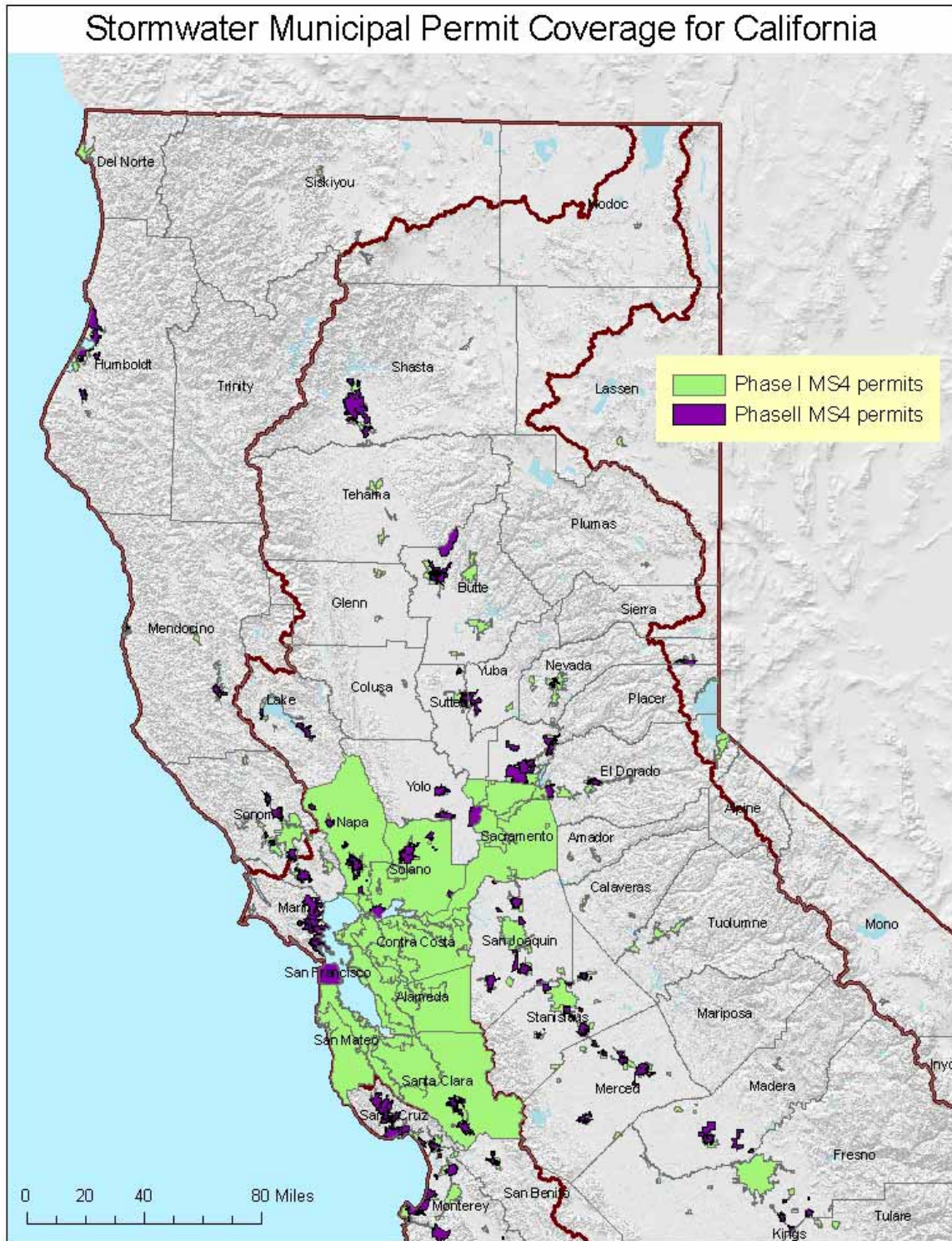

Figure 3 - Northern CA (2009) Counties / Cities With SUSMP-Plus Coverage



Figure 4 - Southern CA (2009) Counties / Cities With SUSMP-Plus Coverage

Water Quality:

This General Permit requires dischargers to replicate the pre-project runoff water balance (defined as the amount of rainfall that ends up as runoff) for the smallest storms up to the 85th percentile storm event, or the smallest storm event that generates runoff, whichever is larger. Contemporary storm water management generally routes these flows directly to the drainage system, increasing pollutant loads and potentially causing adverse effects on receiving waters. These smaller water quality events happen much more frequently than larger events and generate much higher pollutant loads on an annual basis. There are other adverse hydrological impacts that result from not designing according to the site's pre-construction water balance. In Maryland, Klein²¹ noted that baseflow decreases as the extent of urbanization increases. Ferguson and Suckling²² noted a similar relation in watersheds in Georgia. On Long Island, Spinello and Simmons²³ noted substantial decreases in base flow in intensely urbanized watersheds.

The permit emphasizes runoff reduction through on-site storm water reuse, interception, evapotranspiration and infiltration through non-structural controls and conservation design measures (e.g., downspout disconnection, soil quality preservation/enhancement, interceptor trees). Employing these measures close to the source of runoff generation is the easiest and most cost-effective way to comply with the pre-construction water balance standard. Using low-tech runoff reduction techniques close to the source is consistent with a number of recommendations in the literature.²⁴ In many cases, BMPs implemented close to the source of runoff generation cost less than end-of the pipe measures.²⁵ Dischargers are given the option of using Appendix 2 to calculate the required runoff volume or a watershed process-based, continuous simulation model such as the EPA's Storm Water Management Model (SWMM) or Hydrologic Simulation Program Fortran (HSPF). Such methods used by the discharger will be reviewed by the Regional Water Board upon NOT application.

Channel Protection:

In order to address channel protection, a basic understanding of fluvial geomorphic concepts is necessary. A dominant paradigm in fluvial geomorphology holds that streams adjust their channel dimensions (width and depth) in response to long-term changes in sediment supply and bankfull discharge (1.5 to 2 year recurrence interval). The bankfull stage corresponds to the discharge at which channel maintenance is the most effective, that is, the discharge at which the moving sediment, forming or removing bars, forming or changing bends and meanders, and generally doing work that results in the average morphologic characteristics of channels.²⁶ Lane (1955 as cited in Rosgen 1996²⁷) showed the generalized relationship between sediment load, sediment size, stream discharge and stream slope in Figure 5. A change in any one of these variables sets up a series of mutual adjustments in the companion variables with a resulting direct change in the physical characteristics of the stream channel.

²¹ Klein 1979 as cited in Delaware Department of Natural Resources (DDNR). 2004. Green Technology: The Delaware Urban Runoff Management Approach. Dover, DE. 117 pp.

²² Ferguson and Suckling 1990 as cited Delaware Department of Natural Resources (DDNR). 2004. Green Technology: The Delaware Urban Runoff Management Approach. Dover, DE. 117 pp.

²³ Center for Watershed Protection (CWP). 2000. The Practice of Watershed Protection: Techniques for protecting our nation's streams, lakes, rivers, and estuaries. Ellicott City, MD. 741 pp.

²⁴ Bay Area Storm Water Management Agencies Association (BASMAA). 1997. Start at the Source: Residential Site Planning and Design Guidance Manual for Storm Water Quality Protection. Palo Alto, CA;

McCuen, R.H. 2003 Smart Growth: hydrologic perspective. Journal of Professional Issues in Engineering Education and Practice. Vol (129), pp.151-154;

Moglen, G.E. and S. Kim. 2007. Impervious imperviousness-are threshold based policies a good idea? Journal of the American Planning Association, Vol 73 No. 2. pp 161-171.

²⁵ Delaware Department of natural Resources (DDNR). 2004. Green technology: The Delaware urban Runoff Management Approach. Dover, DE. 117 pp.

²⁶ Dunne, T and L.B. Leopold. 1978. Water in Environmental Planning. San Francisco W.H. Freeman and Company

²⁷ Rosgen. D.L. 1996. Applied River Morphology. Pagosa Springs. Wildland Hydrology

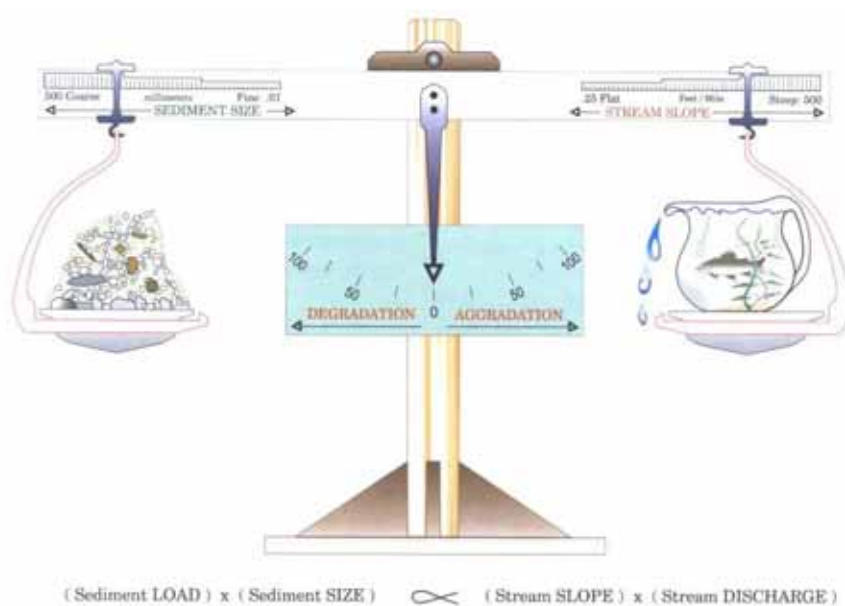

Figure 5 - Schematic of the Lane Relationship

After Lane (1955) as cited in Rosgen (1996)

Stream slope multiplied by stream discharge (the right side of the scale) is essentially an approximation of stream power, a unifying concept in fluvial geomorphology (Bledsoe 1999). Urbanization generally increases stream power and affects the resisting forces in a channel (sediment load and sediment size represented on the left side of the scale).

During construction, sediment loads can increase from 2 to 40,000 times over pre-construction levels.²⁸ Most of this sediment is delivered to stream channels during large, episodic rain events.²⁹ This increased sediment load leads to an initial aggradation phase where stream depths may decrease as sediment fills the channel, leading to a decrease in channel capacity and increase in flooding and overbank deposition. A degradation phase initiates after construction is completed.

Schumm et. al (1984) developed a channel evolution model that describes the series of adjustments from initial downcutting, to widening, to establishing new floodplains at lower elevations (Figure 6).

²⁸ Goldman S.J., K. Jackson, and T.A. Bursztynsky. 1986. Erosion and Sediment Control Handbook. McGraw Hill. San Francisco.

²⁹ Wolman 1967 as cited in Paul, M.P. and J.L. Meyer. 2001. Streams in the Urban Landscape. *Annu. Rev.Ecol. Syst.* 32: 333-365.

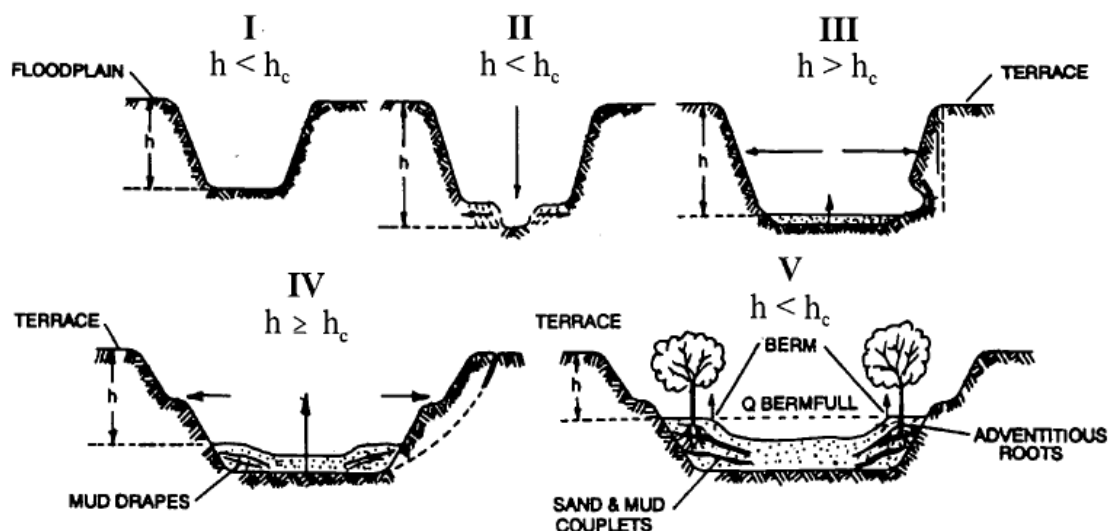

Figure 6 - Channel Changes Associated with Urbanization

After Incised Channel Evolution Sequence in Schumm et. al 1984

Channel incision (Stage II) and widening (Stages III and to a lesser degree, Stage IV) are due to a number of fundamental changes on the landscape. Connected impervious area and compaction of pervious surfaces increase the frequency and volume of bankfull discharges.³⁰ Increased drainage density (miles of stream length per square mile of watershed) also negatively impacts receiving stream channels.³¹ Increased drainage density and hydraulic efficiency leads to an increase in the frequency and volume of bankfull discharges because the time of concentration is shortened. Flows from engineered pipes and channels are also often “sediment starved” and seek to replenish their sediment supply from the channel.

Encroachment of stream channels can also lead to an increase in stream slope, which leads to an increase in stream power. In addition, watershed sediment loads and sediment size (with size generally represented as the median bed and bank particle size, or d_{50}) decrease during urbanization.³² This means that even if pre- and post-development stream power are the same, more erosion will occur in the post-development stage because the smaller particles are less resistant (provided they are non-cohesive).

³⁰ Booth, D. B. and C. R. Jackson. 1997. Urbanization of Aquatic Systems: Degradation Thresholds, Storm Water Detection, and the Limits of Mitigation. *Journal of the American Water Resources Association* Vol. 33, No.5, pp. 1077-1089.

³¹ May, C.W. 1998. Cumulative effects of urbanization on small streams in the Puget Sound Lowland ecoregion. Conference proceedings from Puget Sound Research '98 held March 12, 13 1998 in Seattle, WA; Santa Clara Valley Urban Runoff Pollution Prevention Program. 2002. Hydromodification Management Plan Literature Review. 80 pp.

³² Finkenbine, J.K., D.S. Atwater, and D.S. Mavinic. 2000. Stream health after urbanization. *J. Am. Water Resour. Assoc.* 36:1149-60;

Pizzuto, J.E. W.S. Hession, and M. McBride. 2000. Comparing gravel-bed rivers in paired urban and rural catchments of southeastern Pennsylvania. *Geology* 28:79-82.

As shown in Stages II and III, the channel deepens and widens to accommodate the increased stream power³³ and decrease in sediment load and sediment size. Channels may actually narrow as entrained sediment from incision is deposited laterally in the channel. After incised channels begin to migrate laterally (Stage III), bank erosion begins, which leads to general channel widening.³⁴ At this point, a majority of the sediment that leaves a drainage area comes from within the channel, as opposed to the background and construction related hillslope contribution. Stage IV is characterized by more aggradation and localized bank instability. Stage V represents a new quasi-equilibrium channel morphology in balance with the new flow and sediment supply regime. In other words, stream power is in balance with sediment load and sediment size.

The magnitude of the channel morphology changes discussed above varies along a stream network as well as with the age of development, slope, geology (sand-bedded channels may cycle through the evolution sequence in a matter of decades whereas clay-dominated channels may take much longer), watershed sediment load and size, type of urbanization, and land use history. It is also dependent on a channel's stage in the channel evolution sequence when urbanization occurs. Management strategies must take into account a channel's stage of adjustment and account for future changes in the evolution of channel form (Stein and Zaleski 2005).³⁵

Traditional structural water quality BMPs (e.g. detention basins and other devices used to store volumes of runoff) unless they are highly engineered to provide adequate flow duration control, do not adequately protect receiving waters from accelerated channel bed and bank erosion, do not address post-development increases in runoff volume, and do not mitigate the decline in benthic macroinvertebrate communities in the receiving waters³⁶ suggest that structural BMPs are not as effective in protecting aquatic communities as a continuous riparian buffer of native vegetation. This is supported by the findings of Zucker and White³⁷, where instream biological metrics were correlated with the extent of forested buffers.

This General Permit requires dischargers to maintain pre-development drainage densities and times of concentration in order to protect channels and encourages dischargers to implement setbacks to reduce channel slope and velocity changes that can lead to aquatic habitat degradation.

There are a number of other approaches for modeling fluvial systems, including statistical and physical models and simpler stream power models.³⁸ The use of these models in California is described in Stein and Zaleski (2005).³⁹ Rather than prescribe a specific one-size-fits-all modeling method in this permit, the State Water Board intends to develop a stream power and channel evolution model-based framework to assess channels and develop a hierarchy of suitable analysis methods and management strategies. In time, this framework may become a State Water Board water quality control policy.

³³ Hammer 1973 as cited in Delaware Department of Natural Resources (DDNR). 2004. Green Technology: The Delaware Urban Runoff Management Approach. Dover, DE. 117 pp;
Booth, D.B. 1990. Stream Channel Incision Following Drainage Basin Urbanization. *Water Resour. Bull.* 26:407-417.

³⁴ Trimble, S.W. 1997. Contribution of Stream Channel Erosion to Sediment Yield from an Urbanizing Watershed. *Science*: Vol. 278 (21), pp. 1442-1444.

³⁵ Stein, E.S. and S. Zaleski. 2005. Managing runoff to protect natural stream: the latest developments on investigation and management of hydromodification in California. Southern California Coastal Water Research Project Technical Report 475. 26 pp.

³⁶ Horner, R.R. 2006. Investigation of the Feasibility and Benefits of Low-Impact Site Design Practices (LID) for the San Diego Region. Available at: http://www.projectcleanwater.org/pdf/permit/case-study_lid.pdf.

³⁷ Delaware Department of Natural Resources (DDNR). 2004. Green Technology: The Delaware Urban Runoff Management Approach. Dover, DE. 117 pp.

³⁸ Finlayson, D.P. and D.R. Montgomery. 2003. Modeling large-scale fluvial erosion in geographic information systems. *Geomorphology* (53), pp. 147-164).

³⁹ Stein, E.S. and S. Zaleski. 2005. Managing runoff to protect natural stream: the latest developments on investigation and management of hydromodification in California. Southern California Coastal Water Research Project Technical Report 475. 26 pp.

Permit Linkage to Overbank and Extreme Flood Protection

Site design BMPs (e.g. rooftop and impervious disconnection, vegetated swales, setbacks and buffers) filter and settle out pollutants and provide for more infiltration than is possible for traditional centralized structural BMPs placed at the lowest point in a site. They provide source control for runoff and lead to a reduction in pollutant loads. When implemented, they also help reduce the magnitude and volume of larger, less frequent storm events (e.g., 10-yr, 24-hour storm and larger), thereby reducing the need for expensive flood control infrastructure. Nonstructural BMPs can also be a landscape amenity, instead of a large isolated structure requiring substantial area for ancillary access, buffering, screening and maintenance facilities.²⁵ The multiple benefits of using non-structural benefits will be critically important as the state's population increases and imposes strains upon our existing water resources.

Maintaining predevelopment drainage densities and times of concentration will help reduce post-development peak flows and volumes in areas not covered under a municipal permit. The most effective way to preserve drainage areas and maximize time of concentration is to implement landform grading, incorporate site design BMPs and implement distributed structural BMPs (e.g., bioretention cells, rain gardens, rain cisterns).

M. Storm Water Pollution Prevention Plans

USEPA's Construction General Permit requires that qualified personnel conduct inspections. USEPA defines qualified personnel as "a person knowledgeable in the principles and practice of erosion and sediment controls who possesses the skills to assess conditions at the construction site that could impact storm water quality and to assess the effectiveness of any sediment and erosion control measures selected to control the quality of storm water discharges from the construction activity."⁴⁰ USEPA also suggests that qualified personnel prepare SWPPPs and points to numerous states that require certified professionals to be on construction sites at all times. States that currently have certification programs are Washington, Georgia, Florida, Delaware, Maryland, and New Jersey. The Permit 99-08-DWQ did not require that qualified personnel prepare SWPPPs or conduct inspections. However, to ensure that water quality is being protected, this General Permit requires that all SWPPPs be written, amended, and certified by a Qualified SWPPP Developer. A Qualified SWPPP Developer must possess one of the eight certifications and or registrations specified in this General Permit and effective two years after the adoption date of this General Permit, must have attended a State Water Board-sponsored or approved Qualified SWPPP Developer training course. Table 9 provides an overview of the criteria used in determining qualified certification titles for a QSD and QSP.

40 US Environmental Protection Agency. Stormwater Pollution Prevention Plans for Construction Activities. <<http://cfpub.epa.gov/npdes/stormwater/swppp.cfm>> and <http://www.epa.gov/npdes/pubs/sw_swppp_guide.pdf>.

Table 9 - Qualified SWPPP Developer/ Qualified SWPPP Practitioner Certification Criteria

Certification/ Title	Registered By	QSD/QSP	Certification Criteria
Professional Civil Engineer	California	Both	1. Approval Process 2. Code of Ethics 3. Accountability 4. Pre-requisites
Professional Geologist or Engineering Geologist	California	Both	1. Approval Process 2. Code of Ethics 3. Accountability 4. Pre-requisites
Landscape Architect	California	Both	1. Approval Process 2. Code of Ethics 3. Accountability 4. Pre-requisites
Professional Hydrologist	American Institute of Hydrology	Both	1. Approval Process 2. Code of Ethics 3. Accountability 4. Pre-requisites
Certified Professional in Erosion and Sediment Control™ (CPESC)	Enviro Cert International Inc.	Both	1. Approval Process 2. Code of Ethics 3. Accountability 4. Pre-requisites 5. Continuing Education
Certified Inspector of Sediment and Erosion Control™ (CISEC)	Certified Inspector of Sediment and Erosion Control, Inc.	QSP	1. Approval Process 2. Code of Ethics 3. Accountability 4. Pre-requisites 5. Continuing Education
Certified Erosion, Sediment and Storm Water Inspector™ (CESSWI)	Enviro Cert International Inc.	QSP	1. Approval Process 2. Code of Ethics 3. Accountability 4. Pre-requisites 5. Continuing Education
Certified Professional in Storm Water Quality™ (CPSWQ)	Enviro Cert International Inc.	Both	1. Approval Process 2. Code of Ethics 3. Accountability 4. Pre-requisites 5. Continuing Education

The previous versions of the General Permit required development and implementation of a SWPPP as the primary compliance mechanism. The SWPPP has two major objectives: (1) to help identify the sources of sediment and other pollutants that affect the quality of storm water discharges; and (2) to describe and ensure the implementation of BMPs to reduce or eliminate sediment and other pollutants in storm water and non-storm water discharges. The SWPPP must include BMPs that address source control, BMPs that address pollutant control, and BMPs that address treatment control.

This General Permit shifts some of the measures that were covered by this general requirement to specific permit requirements, each individually enforceable as a permit term. This General Permit emphasizes the use of appropriately selected, correctly installed and maintained pollution reduction BMPs. This approach provides the flexibility necessary to establish BMPs that can effectively address source control of pollutants during changing construction activities. These specific requirements also improve both the clarity and the enforceability of the General Permit so that the dischargers understand, and the public can determine whether the discharges are in compliance with, permit requirements.

The SWPPP must be implemented at the appropriate level to protect water quality at all times throughout the life of the project. The SWPPP must remain on the site during construction activities, commencing with the initial mobilization and ending with the termination of coverage under the General Permit. For LUPs the discharger shall make the SWPPP available at the construction site during working hours while construction is occurring and shall be made available upon request by a State or Municipal inspector. When the original SWPPP is retained by a crewmember in a construction vehicle and is not currently at the construction site, current copies of the BMPs and map/drawing will be left with the field crew and the original SWPPP shall be made available via a request by radio or telephone. Once construction activities are complete, until stabilization is achieved, the SWPPP shall be available from the SWPPP contact listed in the PRDs

A SWPPP must be appropriate for the type and complexity of a project and will be developed and implemented to address project specific conditions. Some projects may have similarities or complexities, yet each project is unique in its progressive state that requires specific description and selection of BMPs needed to address all possible generated pollutants

N. Regional Water Board Authorities

Because this General Permit will be issued to thousands of construction sites across the State, the Regional Water Boards retain discretionary authority over certain issues that may arise from the discharges in their respective regions. This General Permit does not grant the Regional Water Boards any authority they do not otherwise have; rather, it merely emphasizes that the Regional Water Boards can take specific actions related to this General Permit. For example, the Regional Water Boards will be enforcing this General Permit and may need to adjust some requirements for a discharger based on the discharger's compliance history.



Linda S. Adams
Secretary for
Environmental Protection

State Water Resources Control Board



Arnold Schwarzenegger
Governor

Division of Water Quality

1001 I Street • Sacramento, California 95814 • (916) 341-5455
Mailing Address: P.O. Box 100 • Sacramento, California • 95812-0100
Fax (916) 341-5463 • <http://www.waterboards.ca.gov>

NATIONAL POLLUTANT DISCHARGE ELIMINATION SYSTEM (NPDES)
GENERAL PERMIT FOR
STORM WATER DISCHARGES
ASSOCIATED WITH CONSTRUCTION AND LAND DISTURBANCE
ACTIVITIES

ORDER NO. 2009-0009-DWQ
NPDES NO. **CAS000002**

This Order was adopted by the State Water Resources Control Board on:	September 2, 2009
This Order shall become effective on:	July 1, 2010
This Order shall expire on:	September 2, 2014

IT IS HEREBY ORDERED, that this Order supersedes [Order No. 99-08-DWQ](#) except for enforcement purposes. The Discharger shall comply with the requirements in this Order to meet the provisions contained in Division 7 of the California Water Code (commencing with section 13000) and regulations adopted thereunder, and the provisions of the federal Clean Water Act and regulations and guidelines adopted thereunder.

I, Jeanine Townsend, Clerk to the Board, do hereby certify that this Order with all attachments is a full, true, and correct copy of an Order adopted by the State Water Resources Control Board, on September 2, 2009.

AYE: Vice Chair Frances Spivy-Weber
Board Member Arthur G. Baggett, Jr.
Board Member Tam M. Doduc

NAY: Chairman Charles R. Hoppin

ABSENT: None

ABSTAIN: None

Jeanine Townsend
Clerk to the Board

TABLE OF CONTENTS

I.	FINDINGS	1
II.	CONDITIONS FOR PERMIT COVERAGE.....	14
III.	DISCHARGE PROHIBITIONS.....	20
IV.	SPECIAL PROVISIONS.....	22
V.	EFFLUENT STANDARDS	29
VI.	RECEIVING WATER LIMITATIONS	32
VII.	TRAINING QUALIFICATIONS AND CERTIFICATION REQUIREMENTS.....	33
VIII.	RISK DETERMINATION	34
IX.	RISK LEVEL 1 REQUIREMENTS.....	35
X.	RISK LEVEL 2 REQUIREMENTS.....	35
XI.	RISK LEVEL 3 REQUIREMENTS.....	35
XII.	ACTIVE TREATMENT SYSTEMS (ATS).....	35
XIII.	POST-CONSTRUCTION STANDARDS	36
XIV.	SWPPP REQUIREMENTS	38
XV.	REGIONAL WATER BOARD AUTHORITIES.....	39
XVI.	ANNUAL REPORTING REQUIREMENTS.....	40

LIST OF ATTACHMENTS

Attachment A – Linear Underground/Overhead Requirements
Attachment A.1 – LUP Type Determination
Attachment A.2 – LUP Permit Registration Documents
Attachment B – Permit Registration Documents
Attachment C – Risk Level 1 Requirements
Attachment D – Risk Level 2 Requirements
Attachment E – Risk Level 3 Requirements
Attachment F – Active Treatment System (ATS) Requirements

LIST OF APPENDICES

Appendix 1 – Risk Determination Worksheet
Appendix 2 – Post-Construction Water Balance Performance Standard
Appendix 2.1 – Post-Construction Water Balance Performance Standard Spreadsheet
Appendix 3 – Bioassessment Monitoring Guidelines
Appendix 4 – Adopted/Implemented Sediment TMDLs
Appendix 5 – Glossary
Appendix 6 – Acronyms
Appendix 7 – State and Regional Water Resources Control Board Contacts

**STATE WATER RESOURCES CONTROL BOARD
ORDER NO. 2009-0009-DWQ
NATIONAL POLLUTANT DISCHARGE ELIMINATION SYSTEM
GENERAL PERMIT NO. CAS000002**

**WASTE DISCHARGE REQUIREMENTS
FOR
DISCHARGES OF STORM WATER RUNOFF ASSOCIATED WITH
CONSTRUCTION AND LAND DISTURBANCE ACTIVITIES**

I. FINDINGS

A. General Findings

The State Water Resources Control Board (State Water Board) finds that:

1. The federal Clean Water Act (CWA) prohibits certain discharges of storm water containing pollutants except in compliance with a National Pollutant Discharge Elimination System (NPDES) permit (Title 33 United States Code (U.S.C.) §§ 1311 and 1342(p); also referred to as Clean Water Act (CWA) §§ 301 and 402(p)). The U.S. Environmental Protection Agency (U.S. EPA) promulgates federal regulations to implement the CWA's mandate to control pollutants in storm water runoff discharges. (Title 40 Code of Federal Regulations (C.F.R.) Parts 122, 123, and 124). The federal statutes and regulations require discharges to surface waters comprised of storm water associated with construction activity, including demolition, clearing, grading, and excavation, and other land disturbance activities (except operations that result in disturbance of less than one acre of total land area and which are not part of a larger common plan of development or sale), to obtain coverage under an NPDES permit. The NPDES permit must require implementation of Best Available Technology Economically Achievable (BAT) and Best Conventional Pollutant Control Technology (BCT) to reduce or eliminate pollutants in storm water runoff. The NPDES permit must also include additional requirements necessary to implement applicable water quality standards.
2. This General Permit authorizes discharges of storm water associated with construction activity so long as the dischargers comply with all requirements, provisions, limitations and prohibitions in the permit. In addition, this General Permit regulates the discharges of storm water associated with construction activities from all Linear Underground/Overhead Projects resulting in the disturbance of greater than or equal to one acre (Attachment A).

3. This General Permit regulates discharges of pollutants in storm water associated with construction activity (storm water discharges) to waters of the United States from construction sites that disturb one or more acres of land surface, or that are part of a common plan of development or sale that disturbs more than one acre of land surface.
4. This General Permit does not preempt or supersede the authority of local storm water management agencies to prohibit, restrict, or control storm water discharges to municipal separate storm sewer systems or other watercourses within their jurisdictions.
5. This action to adopt a general NPDES permit is exempt from the provisions of Chapter 3 of the California Environmental Quality Act (CEQA) (Public Resources Code Section 21100, et seq.), pursuant to Section 13389 of the California Water Code.
6. Pursuant to 40 C.F.R. § 131.12 and State Water Board [Resolution No. 68-16](#),¹ which incorporates the requirements of § 131.12 where applicable, the State Water Board finds that discharges in compliance with this General Permit will not result in the lowering of water quality standards, and are therefore consistent with those provisions. Compliance with this General Permit will result in improvements in water quality.
7. This General Permit serves as an NPDES permit in compliance with CWA § 402 and will take effect on July 1, 2010 by the State Water Board provided the Regional Administrator of the U.S. EPA has no objection. If the U.S. EPA Regional Administrator objects to its issuance, the General Permit will not become effective until such objection is withdrawn.
8. Following adoption and upon the effective date of this General Permit, the Regional Water Quality Control Boards (Regional Water Boards) shall enforce the provisions herein.
9. Regional Water Boards establish water quality standards in Basin Plans. The State Water Board establishes water quality standards in various statewide plans, including the California Ocean Plan. U.S. EPA establishes water quality standards in the National Toxic Rule (NTR) and the California Toxic Rule (CTR).

¹ Resolution No. 68-16 generally requires that existing water quality be maintained unless degradation is justified based on specific findings.

10. This General Permit does not authorize discharges of fill or dredged material regulated by the U.S. Army Corps of Engineers under CWA § 404 and does not constitute a waiver of water quality certification under CWA § 401.
11. The primary storm water pollutant at construction sites is excess sediment. Excess sediment can cloud the water, which reduces the amount of sunlight reaching aquatic plants, clog fish gills, smother aquatic habitat and spawning areas, and impede navigation in our waterways. Sediment also transports other pollutants such as nutrients, metals, and oils and greases.
12. Construction activities can impact a construction site's runoff sediment supply and transport characteristics. These modifications, which can occur both during and after the construction phase, are a significant cause of degradation of the beneficial uses established for water bodies in California. Dischargers can avoid these effects through better construction site design and activity practices.
13. This General Permit recognizes four distinct phases of construction activities. The phases are Grading and Land Development Phase, Streets and Utilities Phase, Vertical Construction Phase, and Final Landscaping and Site Stabilization Phase. Each phase has activities that can result in different water quality effects from different water quality pollutants. This General Permit also recognizes inactive construction as a category of construction site type.
14. Compliance with any specific limits or requirements contained in this General Permit does not constitute compliance with any other applicable requirements.
15. Following public notice in accordance with State and Federal laws and regulations, the State Water Board heard and considered all comments and testimony in a public hearing on 06/03/2009. The State Water Board has prepared written responses to all significant comments.
16. Construction activities obtaining coverage under the General Permit may have multiple discharges subject to requirements that are specific to general, linear, and/or active treatment system discharge types.
17. The State Water Board may reopen the permit if the U.S. EPA adopts a final effluent limitation guideline for construction activities.

B. Activities Covered Under the General Permit

18. Any construction or demolition activity, including, but not limited to, clearing, grading, grubbing, or excavation, or any other activity that results in a land disturbance of equal to or greater than one acre.
19. Construction activity that results in land surface disturbances of less than one acre if the construction activity is part of a larger common plan of development or the sale of one or more acres of disturbed land surface.
20. Construction activity related to residential, commercial, or industrial development on lands currently used for agriculture including, but not limited to, the construction of buildings related to agriculture that are considered industrial pursuant to U.S. EPA regulations, such as dairy barns or food processing facilities.
21. Construction activity associated with Linear Underground/Overhead Utility Projects (LUPs) including, but not limited to, those activities necessary for the installation of underground and overhead linear facilities (e.g., conduits, substructures, pipelines, towers, poles, cables, wires, connectors, switching, regulating and transforming equipment and associated ancillary facilities) and include, but are not limited to, underground utility mark-out, potholing, concrete and asphalt cutting and removal, trenching, excavation, boring and drilling, access road and pole/tower pad and cable/wire pull station, substation construction, substructure installation, construction of tower footings and/or foundations, pole and tower installations, pipeline installations, welding, concrete and/or pavement repair or replacement, and stockpile/borrow locations.
22. Discharges of sediment from construction activities associated with oil and gas exploration, production, processing, or treatment operations or transmission facilities.²
23. Storm water discharges from dredge spoil placement that occur outside of U.S. Army Corps of Engineers jurisdiction (upland sites) and that disturb one or more acres of land surface from construction activity are covered by this General Permit. Construction sites that intend to disturb one or more acres of land within the jurisdictional boundaries of a CWA § 404 permit should contact the appropriate Regional Water Board to determine whether this permit applies to the site.

² Pursuant to the Ninth Circuit Court of Appeals' decision in *NRDC v. EPA* (9th Cir. 2008) 526 F.3d 591, and subsequent denial of the U.S. EPA's petition for reconsideration in November 2008, oil and gas construction activities discharging storm water contaminated only with sediment are no longer exempt from the NPDES program.

C. Activities Not Covered Under the General Permit

24. Routine maintenance to maintain original line and grade, hydraulic capacity, or original purpose of the facility.
25. Disturbances to land surfaces solely related to agricultural operations such as disking, harrowing, terracing and leveling, and soil preparation.
26. Discharges of storm water from areas on tribal lands; construction on tribal lands is regulated by a federal permit.
27. Construction activity and land disturbance involving discharges of storm water within the Lake Tahoe Hydrologic Unit. The Lahontan Regional Water Board has adopted its own permit to regulate storm water discharges from construction activity in the Lake Tahoe Hydrologic Unit (Regional Water Board 6SLT). Owners of construction sites in this watershed must apply for the Lahontan Regional Water Board permit rather than the statewide Construction General Permit.
28. Construction activity that disturbs less than one acre of land surface, and that is not part of a larger common plan of development or the sale of one or more acres of disturbed land surface.
29. Construction activity covered by an individual NPDES Permit for storm water discharges.
30. Discharges from small (1 to 5 acre) construction activities with an approved Rainfall Erosivity Waiver authorized by U.S. EPA Phase II regulations certifying to the State Board that small construction activity will occur only when the Rainfall Erosivity Factor is less than 5 ("R" in the Revised Universal Soil Loss Equation).
31. Landfill construction activity that is subject to the Industrial General Permit.
32. Construction activity that discharges to Combined Sewer Systems.
33. Conveyances that discharge storm water runoff combined with municipal sewage.
34. Discharges of storm water identified in CWA § 402(1)(2), 33 U.S.C. § 1342(1)(2).

35. Discharges occurring in basins that are not tributary or hydrologically connected to waters of the United States (for more information contact your Regional Water Board).

D. Obtaining and Modifying General Permit Coverage

36. This General Permit requires all dischargers to electronically file all Permit Registration Documents (PRDs), Notices of Termination (NOT), changes of information, annual reporting, and other compliance documents required by this General Permit through the State Water Board's Storm water Multi-Application and Report Tracking System (SMARTS) website.
37. Any information provided to the Regional Water Board shall comply with the Homeland Security Act and any other federal law that concerns security in the United States; any information that does not comply should not be submitted.
38. This General Permit grants an exception from the Risk Determination requirements for existing sites covered under Water Quality Orders No. 99-08-DWQ, and [No. 2003-0007-DWQ](#). For certain sites, adding additional requirements may not be cost effective. Construction sites covered under Water Quality Order No. 99-08-DWQ shall obtain permit coverage at the Risk Level 1. LUPs covered under Water Quality Order No. 2003-0007-DWQ shall obtain permit coverage as a Type 1 LUP. The Regional Water Boards have the authority to require Risk Determination to be performed on sites currently covered under Water Quality Orders No. 99-08-DWQ and No. 2003-0007-DWQ where they deem it necessary. The State Water Board finds that there are two circumstances when it may be appropriate for the Regional Water Boards to require a discharger that had filed an NOI under State Water Board Order No. 99-08-DWQ to recalculate the site's risk level. These circumstances are: (1) when the discharger has a demonstrated history of noncompliance with State Water Board Order No. 99-08-DWQ or; (2) when the discharger's site poses a significant risk of causing or contributing to an exceedance of a water quality standard without the implementation of the additional Risk Level 2 or 3 requirements.

E. Prohibitions

39. All discharges are prohibited except for the storm water and non-storm water discharges specifically authorized by this General Permit or another NPDES permit. Non-storm water discharges include a wide variety of sources, including improper dumping, spills, or leakage from storage tanks or transfer areas. Non-storm water discharges may

contribute significant pollutant loads to receiving waters. Measures to control spills, leakage, and dumping, and to prevent illicit connections during construction must be addressed through structural as well as non-structural Best Management Practices (BMPs)³. The State Water Board recognizes, however, that certain non-storm water discharges may be necessary for the completion of construction.

40. This General Permit prohibits all discharges which contain a hazardous substance in excess of reportable quantities established in 40 C.F.R. §§ 117.3 and 302.4, unless a separate NPDES Permit has been issued to regulate those discharges.
41. This General Permit incorporates discharge prohibitions contained in water quality control plans, as implemented by the State Water Board and the nine Regional Water Boards.
42. Pursuant to the Ocean Plan, discharges to Areas of Special Biological Significance (ASBS) are prohibited unless covered by an exception that the State Water Board has approved.
43. This General Permit prohibits the discharge of any debris⁴ from construction sites. Plastic and other trash materials can cause negative impacts to receiving water beneficial uses. The State Water Board encourages the use of more environmentally safe, biodegradable materials on construction sites to minimize the potential risk to water quality.

F. Training

44. In order to improve compliance with and to maintain consistent enforcement of this General Permit, all dischargers are required to appoint two positions - the Qualified SWPPP Developer (QSD) and the Qualified SWPPP Practitioner (QSP) - who must obtain appropriate training. Together with the key stakeholders, the State and Regional Water Boards are leading the development of this curriculum through a collaborative organization called The Construction General Permit (CGP) Training Team.
45. The Professional Engineers Act (Bus. & Prof. Code section 6700, et seq.) requires that all engineering work must be performed by a California licensed engineer.

³ BMPs are scheduling of activities, prohibitions of practices, maintenance procedures, and other management practices to prevent or reduce the discharge of pollutants to waters of the United States. BMPs also include treatment requirements, operating procedures, and practice to control site runoff, spillage or leaks, sludge or waste disposal, or drainage from raw material storage.

⁴ Litter, rubble, discarded refuse, and remains of destroyed inorganic anthropogenic waste.

G. Determining and Reducing Risk

46. The risk of accelerated erosion and sedimentation from wind and water depends on a number of factors, including proximity to receiving water bodies, climate, topography, and soil type.
47. This General Permit requires dischargers to assess the risk level of a site based on both sediment transport and receiving water risk. This General Permit contains requirements for Risk Levels 1, 2 and 3, and LUP Risk Type 1, 2, and 3 (Attachment A). Risk levels are established by determining two factors: first, calculating the site's sediment risk; and second, receiving water risk during periods of soil exposure (i.e. grading and site stabilization). Both factors are used to determine the site-specific Risk Level(s). LUPs can be determined to be Type 1 based on the flowchart in Attachment A.1.
48. Although this General Permit does not mandate specific setback distances, dischargers are encouraged to set back their construction activities from streams and wetlands whenever feasible to reduce the risk of impacting water quality (e.g., natural stream stability and habitat function). Because there is a reduced risk to receiving waters when setbacks are used, this General Permit gives credit to setbacks in the risk determination and post-construction storm water performance standards. The risk calculation and runoff reduction mechanisms in this General Permit are expected to facilitate compliance with any Regional Water Board and local agency setback requirements, and to encourage voluntary setbacks wherever practicable.
49. Rain events can occur at any time of the year in California. Therefore, a Rain Event Action Plan (REAP) is necessary for Risk Level 2 and 3 traditional construction projects (LUPs exempt) to ensure that active construction sites have adequate erosion and sediment controls implemented prior to the onset of a storm event, even if construction is planned only during the dry season.
50. Soil particles smaller than 0.02 millimeters (mm) (i.e., finer than medium silt) do not settle easily using conventional measures for sediment control (i.e., sediment basins). Given their long settling time, dislodging these soils results in a significant risk that fine particles will be released into surface waters and cause unacceptable downstream impacts. If operated correctly, an Active Treatment System (ATS⁵) can prevent or reduce the release of fine particles from construction sites.

⁵ An ATS is a treatment system that employs chemical coagulation, chemical flocculation, or electro coagulation in order to reduce turbidity caused by fine suspended sediment.

Use of an ATS can effectively reduce a site's risk of impacting receiving waters.

51. Dischargers located in a watershed area where a Total Maximum Daily Load (TMDL) has been adopted or approved by the Regional Water Board or U.S. EPA may be required by a separate Regional Water Board action to implement additional BMPs, conduct additional monitoring activities, and/or comply with an applicable waste load allocation and implementation schedule. Such dischargers may also be required to obtain an individual Regional Water Board permit specific to the area.

H. Effluent Standards

52. The State Water Board convened a blue ribbon panel of storm water experts that submitted a report entitled, "The Feasibility of Numeric Effluent Limits Applicable to Discharges of Storm Water Associated with Municipal, Industrial and Construction Activities," dated June 19, 2006. The panel concluded that numeric limits or action levels are technically feasible to control construction storm water discharges, provided that certain conditions are considered. The panel also concluded that numeric effluent limitations (NELs) are feasible for discharges from construction sites that utilize an ATS. The State Water Board has incorporated the expert panel's suggestions into this General Permit, which includes both numeric action levels (NALs) and NELs for pH and turbidity, and special numeric limits for ATS discharges.

Numeric Effluent Limitations

53. Discharges of storm water from construction activities may become contaminated from alkaline construction materials resulting in high pH (greater than pH 7). Alkaline construction materials include, but are not limited to, hydrated lime, concrete, mortar, cement kiln dust (CKD), Portland cement treated base (CTB), fly ash, recycled concrete, and masonry work. This General Permit includes an NEL for pH (6.0-9.0) that applies only at sites that exhibit a "high risk of high pH discharge." A "high risk of high pH discharge" can occur during the complete utilities phase, the complete vertical build phase, and any portion of any phase where significant amounts of materials are placed directly on the land at the site in a manner that could result in significant alterations to the background pH of any discharges.
54. For Risk Level 3 discharges, this General Permit establishes technology-based, numeric effluent limitations (NELs) for turbidity of 500 NTU. Exceedances of the turbidity NEL constitutes a violation of this General Permit.

55. This General Permit establishes a 5 year, 24 hour (expressed in inches of rainfall) Compliance Storm Event exemption from the technology-based NELs for Risk Level 3 dischargers.

Determining Compliance with Numeric Limitations

56. This General Permit sets a pH NAL of 6.5 to 8.5, and a turbidity NAL of 250 NTU. The purpose of the NAL and its associated monitoring requirement is to provide operational information regarding the performance of the measures used at the site to minimize the discharge of pollutants and to protect beneficial uses and receiving waters from the adverse effects of construction-related storm water discharges. The NALs in this General Permit for pH and turbidity are not directly enforceable and do not constitute NELs.
57. This General Permit requires dischargers with NAL exceedances to immediately implement additional BMPs and revise their Storm Water Pollution Prevention Plans (SWPPPs) accordingly to either prevent pollutants and authorized non-storm water discharges from contaminating storm water, or to substantially reduce the pollutants to levels consistently below the NALs. NAL exceedances are reported in the State Water Boards SMARTS system, and the discharger is required to provide an NAL Exceedance Report when requested by a Regional Water Board.
58. If run-on is caused by a forest fire or any other natural disaster, then NELs do not apply.
59. Exceedances of the NELs are a violation of this Permit. This General Permit requires dischargers with NEL exceedances to implement additional monitoring, BMPs, and revise their SWPPPs accordingly. Dischargers are required to notify the State and Regional Water Boards of the violation through the State Water Boards SMARTs system, and provide an NEL Violation Report sharing additional information concerning the NEL exceedance.

I. Receiving Water Limitations

60. This General Permit requires all enrolled dischargers to determine the receiving waters potentially affected by their discharges and to comply with all applicable water quality standards, including any more stringent standards applicable to a water body.

J. Sampling, Monitoring, Reporting and Record Keeping

61. Visual monitoring of storm water and non-storm water discharges is required for all sites subject to this General Permit.

62. Records of all visual monitoring inspections are required to remain on-site during the construction period and for a minimum of three years.
63. For all Risk Level 3 and Risk Level 2 sites, this General Permit requires effluent monitoring for pH and turbidity. Sampling, analysis and monitoring requirements for effluent monitoring for pH and turbidity are contained in this General Permit.
64. Risk Level 3 sites in violation of the Numeric Effluent Limitations contained in this General Permit and with direct discharges to receiving water are required to conduct receiving water monitoring.
65. For Risk Level 3 sites larger than 30 acres and with direct discharges to receiving waters, this General Permit requires bioassessment sampling before and after site completion to determine if significant degradation to the receiving water's biota has occurred. Bioassessment sampling guidelines are contained in this General Permit.
66. A summary and evaluation of the sampling and analysis results will be submitted in the Annual Reports.
67. This General Permit contains sampling, analysis and monitoring requirements for non-visible pollutants at all sites subject to this General Permit.
68. Compliance with the General Permit relies upon dischargers to electronically self-report any discharge violations and to comply with any Regional Water Board enforcement actions.
69. This General Permit requires that all dischargers maintain a paper or electronic copy of all required records for three years from the date generated or date submitted, whichever is last. These records must be available at the construction site until construction is completed. For LUPs, these documents may be retained in a crew member's vehicle and made available upon request.

K. Active Treatment System (ATS) Requirements

70. Active treatment systems add chemicals to facilitate flocculation, coagulation and filtration of suspended sediment particles. The uncontrolled release of these chemicals to the environment can negatively affect the beneficial uses of receiving waters and/or degrade water quality (e.g., acute and chronic toxicity). Additionally, the batch storage and treatment of storm water through an ATS' can potentially

cause physical impacts on receiving waters if storage volume is inadequate or due to sudden releases of the ATS batches and improperly designed outfalls.

71. If designed, operated and maintained properly an ATS can achieve very high removal rates of suspended sediment (measured as turbidity), albeit at sometimes significantly higher costs than traditional erosion/sediment control practices. As a result, this General Permit establishes NELs consistent with the expected level of typical ATS performance.
72. This General Permit requires discharges of storm water associated with construction activity that undergo active treatment to comply with special operational and effluent limitations to ensure that these discharges do not adversely affect the beneficial uses of the receiving waters or cause degradation of their water quality.
73. For ATS discharges, this General Permit establishes technology-based NELs for turbidity.
74. This General Permit establishes a 10 year, 24 hour (expressed in inches of rainfall) Compliance Storm Event exemption from the technology-based numeric effluent limitations for ATS discharges. Exceedances of the ATS turbidity NEL constitutes a violation of this General Permit.

L. Post-Construction Requirements

75. This General Permit includes performance standards for post-construction that are consistent with State Water Board [Resolution No. 2005-0006](#), "Resolution Adopting the Concept of Sustainability as a Core Value for State Water Board Programs and Directing Its Incorporation," and [2008-0030](#), "Requiring Sustainable Water Resources Management." The requirement for all construction sites to match pre-project hydrology will help ensure that the physical and biological integrity of aquatic ecosystems are sustained. This "runoff reduction" approach is analogous in principle to Low Impact Development (LID) and will serve to protect related watersheds and waterbodies from both hydrologic-based and pollution impacts associated with the post-construction landscape.
76. LUP projects are not subject to post-construction requirements due to the nature of their construction to return project sites to pre-construction conditions.

M. Storm Water Pollution Prevention Plan Requirements

77. This General Permit requires the development of a site-specific SWPPP. The SWPPP must include the information needed to demonstrate compliance with all requirements of this General Permit, and must be kept on the construction site and be available for review. The discharger shall ensure that a QSD develops the SWPPP.
78. To ensure proper site oversight, this General Permit requires a Qualified SWPPP Practitioner to oversee implementation of the BMPs required to comply with this General Permit.

N. Regional Water Board Authorities

79. Regional Water Boards are responsible for implementation and enforcement of this General Permit. A general approach to permitting is not always suitable for every construction site and environmental circumstances. Therefore, this General Permit recognizes that Regional Water Boards must have some flexibility and authority to alter, approve, exempt, or rescind permit authority granted under this General Permit in order to protect the beneficial uses of our receiving waters and prevent degradation of water quality.

IT IS HEREBY ORDERED that all dischargers subject to this General Permit shall comply with the following conditions and requirements (including all conditions and requirements as set forth in Attachments A, B, C, D, E and F)⁶:

II. CONDITIONS FOR PERMIT COVERAGE

A. Linear Underground/Overhead Projects (LUPs)

1. Linear Underground/Overhead Projects (LUPs) include, but are not limited to, any conveyance, pipe, or pipeline for the transportation of any gaseous, liquid (including water and wastewater for domestic municipal services), liquescent, or slurry substance; any cable line or wire for the transmission of electrical energy; any cable line or wire for communications (e.g. telephone, telegraph, radio or television messages); and associated ancillary facilities. Construction activities associated with LUPs include, but are not limited to, (a) those activities necessary for the installation of underground and overhead linear facilities (e.g., conduits, substructures, pipelines, towers, poles, cables, wires, connectors, switching, regulating and transforming equipment, and associated ancillary facilities); and include, but are not limited to, (b) underground utility mark-out, potholing, concrete and asphalt cutting and removal, trenching, excavation, boring and drilling, access road and pole/tower pad and cable/wire pull station, substation construction, substructure installation, construction of tower footings and/or foundations, pole and tower installations, pipeline installations, welding, concrete and/ or pavement repair or replacement, and stockpile/borrow locations.
2. The utility company, municipality, or other public or private company or agency that owns or operates the linear underground/overhead project is responsible for obtaining coverage under the General Permit where the construction of pipelines, utility lines, fiber-optic cables, or other linear underground/overhead projects will occur across several properties unless the LUP construction activities are covered under another construction storm water permit.
3. Only LUPs shall comply with the conditions and requirements in Attachment A, A.1 & A.2 of this Order. The balance of this Order is not applicable to LUPs except as indicated in Attachment A.

B. Obtaining Permit Coverage Traditional Construction Sites

⁶ These attachments are part of the General Permit itself and are not separate documents that are capable of being updated independently by the State Water Board.

1. The Legally Responsible Person (LRP) (see Special Provisions, Electronic Signature and Certification Requirements, Section IV.I.1) must obtain coverage under this General Permit.
2. To obtain coverage, the LRP must electronically file Permit Registration Documents (PRDs) prior to the commencement of construction activity. Failure to obtain coverage under this General Permit for storm water discharges to waters of the United States is a violation of the CWA and the California Water Code.
3. PRDs shall consist of:
 - a. Notice of Intent (NOI)
 - b. Risk Assessment (Section VIII)
 - c. Site Map
 - d. Storm Water Pollution Prevention Plan (Section XIV)
 - e. Annual Fee
 - f. Signed Certification Statement

Any information provided to the Regional Water Board shall comply with the Homeland Security Act and any other federal law that concerns security in the United States; any information that does not comply should not be submitted.

Attachment B contains additional PRD information. Dischargers must electronically file the PRDs, and mail the appropriate annual fee to the State Water Board.

4. This permit is effective on July 1, 2010.
 - a. **Dischargers Obtaining Coverage On or After July 1, 2010:** All dischargers requiring coverage on or after July 1, 2010, shall electronically file their PRDs prior to the commencement of construction activities, and mail the appropriate annual fee no later than seven days prior to the commencement of construction activities. Permit coverage shall not commence until the PRDs and the annual fee are received by the State Water Board, and a WDID number is assigned and sent by SMARTS.
 - b. **Dischargers Covered Under 99-08-DWQ and 2003-0007-DWQ:** Existing dischargers subject to State Water Board Order No. 99-08-DWQ (existing dischargers) will continue coverage under 99-08-DWQ until July 1, 2010. After July 1, 2010, all NOIs subject to State Water Board Order No. 99-08-DWQ will be terminated. Existing dischargers shall electronically file their PRDs no later than

July 1, 2010. If an existing discharger's site acreage subject to the annual fee has changed, it shall mail a revised annual fee no less than seven days after receiving the revised annual fee notification, **or else lose permit coverage**. All existing dischargers shall be exempt from the risk determination requirements in Section VIII of this General Permit until two years after permit adoption. All existing dischargers are therefore subject to Risk Level 1 requirements regardless of their site's sediment and receiving water risks. However, a Regional Board retains the authority to require an existing discharger to comply with the Section VIII risk determination requirements.

5. The discharger is only considered covered by this General Permit upon receipt of a Waste Discharger Identification (WDID) number assigned and sent by the State Water Board Storm water Multi-Application and Report Tracking System (SMARTS). In order to demonstrate compliance with this General Permit, the discharger must obtain a WDID number and must present documentation of a valid WDID upon demand.
6. During the period this permit is subject to review by the U.S. EPA, the prior permit (State Water Board Order No. 99-08-DWQ) remains in effect. Existing dischargers under the prior permit will continue to have coverage under State Water Board Order No. 99-08-DWQ until this General Permit takes effect on July 1, 2010. Dischargers who complete their projects and electronically file an NOI prior to July 1, 2010, are not required to obtain coverage under this General Permit.
7. Small Construction Rainfall Erosivity Waiver

EPA's Small Construction Erosivity Waiver applies to sites between one and five acres demonstrating that there are no adverse water quality impacts.

Dischargers eligible for a Rainfall Erosivity Waiver based on low erosivity potential shall complete the electronic Notice of Intent (NOI) and Sediment Risk form through the State Water Board's SMARTS system, certifying that the construction activity will take place during a period when the value of the rainfall erosivity factor is less than five. Where the LRP changes or another LRP is added during construction, the new LRP must also submit a waiver certification through the SMARTS system.

If a small construction site continues beyond the projected completion date given on the waiver certification, the LRP shall recalculate the rainfall erosivity factor for the new project duration and submit this

information through the SMARTS system. If the new R factor is below five (5), the discharger shall update through SMARTS all applicable information on the waiver certification and retain a copy of the revised waiver onsite. The LRP shall submit the new waiver certification 30 days prior to the projected completion date listed on the original waiver form to assure exemption from permitting requirements is uninterrupted. If the new R factor is five (5) or above, the LRP shall be required to apply for coverage under this Order.

8. In the case of a public emergency that requires immediate construction activities, a discharger shall submit a brief description of the emergency construction activity within five days of the onset of construction, and then shall submit all PRDs within thirty days.

C. Revising Permit Coverage for Change of Acreage or New Ownership

1. The discharger may reduce or increase the total acreage covered under this General Permit when a portion of the site is complete and/or conditions for termination of coverage have been met (See Section II.D Conditions for Termination of Coverage); when ownership of a portion of the site is sold to a different entity; or when new acreage, subject to this General Permit, is added to the site.
2. Within 30 days of a reduction or increase in total disturbed acreage, the discharger shall electronically file revisions to the PRDs that include:
 - a. A revised NOI indicating the new project size;
 - b. A revised site map showing the acreage of the site completed, acreage currently under construction, acreage sold/transferred or added, and acreage currently stabilized in accordance with the Conditions for Termination of Coverage in Section II.D below.
 - c. SWPPP revisions, as appropriate; and
 - d. Certification that any new landowners have been notified of applicable requirements to obtain General Permit coverage. The certification shall include the name, address, telephone number, and e-mail address of the new landowner.
 - e. If the project acreage has increased, dischargers shall mail payment of revised annual fees within 14 days of receiving the revised annual fee notification.

3. The discharger shall continue coverage under the General Permit for any parcel that has not achieved “Final Stabilization” as defined in Section II.D.
4. When an LRP owns property with active General Permit coverage, and the LRP sells the property, or a parcel thereof, to another person, that person shall become an LRP with respect to whatever parcel was sold. The existing LRP shall inform the new LRP of the General Permit’s requirements. In order for the new LRP to continue the construction activity on its parcel of property, the new LRP, or the new LRP’s approved signatory, must submit PRDs in accordance with this General Permit’s requirements.

D. Conditions for Termination of Coverage

1. Within 90 days of when construction is complete or ownership has been transferred, the discharger shall electronically file a Notice of Termination (NOT), a final site map, and photos through the State Water Boards SMARTS system. Filing a NOT certifies that all General Permit requirements have been met. The Regional Water Board will consider a construction site complete only when all portions of the site have been transferred to a new owner, or all of the following conditions have been met:
 - a. For purposes of “final stabilization,” the site will not pose any additional sediment discharge risk than it did prior to the commencement of construction activity;
 - b. There is no potential for construction-related storm water pollutants to be discharged into site runoff;
 - c. Final stabilization has been reached;
 - d. Construction materials and wastes have been disposed of properly;
 - e. Compliance with the Post-Construction Standards in Section XIII of this General Permit has been demonstrated;
 - f. Post-construction storm water management measures have been installed and a long-term maintenance plan⁷ has been established; and

⁷ For the purposes of this requirement a long-term maintenance plan will be designed for a minimum of five years, and will describe the procedures to ensure that the post-construction storm water management measures are adequately maintained.

- g. All construction-related equipment, materials and any temporary BMPs no longer needed are removed from the site.
2. The discharger shall certify that final stabilization conditions are satisfied in their NOT. Failure to certify shall result in continuation of permit coverage and annual billing.
3. The NOT must demonstrate through photos, RUSLE or RUSLE2, or results of testing and analysis that the site meets all of the conditions above (Section II.D.1) and the final stabilization condition (Section II.D.1.a) is attained by one of the following methods:
 - a. "70% final cover method," no computational proof required
 - OR:**
 - b. "RUSLE or RUSLE2 method," computational proof required
 - OR:**
 - c. "Custom method", the discharger shall demonstrate in some other manner than a or b, above, that the site complies with the "final stabilization" requirement in Section II.D.1.a.

III. DISCHARGE PROHIBITIONS

- A.** Dischargers shall not violate any discharge prohibitions contained in applicable Basin Plans or statewide water quality control plans. Waste discharges to Areas of Special Biological Significance (ASBS) are prohibited by the California Ocean Plan, unless granted an exception issued by the State Water Board.
- B.** All discharges are prohibited except for the storm water and non-storm water discharges specifically authorized by this General Permit or another NPDES permit.
- C.** Authorized non-storm water discharges may include those from de-chlorinated potable water sources such as: fire hydrant flushing, irrigation of vegetative erosion control measures, pipe flushing and testing, water to control dust, uncontaminated ground water from dewatering, and other discharges not subject to a separate general NPDES permit adopted by a Regional Water Board. The discharge of non-storm water is authorized under the following conditions:
1. The discharge does not cause or contribute to a violation of any water quality standard;
 2. The discharge does not violate any other provision of this General Permit;
 3. The discharge is not prohibited by the applicable Basin Plan;
 4. The discharger has included and implemented specific BMPs required by this General Permit to prevent or reduce the contact of the non-storm water discharge with construction materials or equipment.
 5. The discharge does not contain toxic constituents in toxic amounts or (other) significant quantities of pollutants;
 6. The discharge is monitored and meets the applicable NALs and NELs; and
 7. The discharger reports the sampling information in the Annual Report.

If any of the above conditions are not satisfied, the discharge is not authorized by this General Permit. The discharger shall notify the Regional Water Board of any anticipated non-storm water discharges not already authorized by this General Permit or another NPDES permit, to determine whether a separate NPDES permit is necessary.

- D.** Debris resulting from construction activities are prohibited from being discharged from construction sites.
- E.** When soil contamination is found or suspected and a responsible party is not identified, or the responsible party fails to promptly take the appropriate action, the discharger shall have those soils sampled and tested to ensure proper handling and public safety measures are implemented. The discharger shall notify the appropriate local, State, and federal agency(ies) when contaminated soil is found at a construction site, and will notify the appropriate Regional Water Board.

IV. SPECIAL PROVISIONS

A. Duty to Comply

1. The discharger shall comply with all of the conditions of this General Permit. Any permit noncompliance constitutes a violation of the Clean Water Act (CWA) and the Porter-Cologne Water Quality Control Act and is grounds for enforcement action and/or removal from General Permit coverage.
2. The discharger shall comply with effluent standards or prohibitions established under Section 307(a) of the CWA for toxic pollutants within the time provided in the regulations that establish these standards or prohibitions, even if this General Permit has not yet been modified to incorporate the requirement.

B. General Permit Actions

1. This General Permit may be modified, revoked and reissued, or terminated for cause. The filing of a request by the discharger for a General Permit modification, revocation and reissuance, or termination, or a notification of planned changes or anticipated noncompliance does not annul any General Permit condition.
2. If any toxic effluent standard or prohibition (including any schedule of compliance specified in such effluent standard or prohibition) is promulgated under Section 307(a) of the CWA for a toxic pollutant which is present in the discharge and that standard or prohibition is more stringent than any limitation on the pollutant in this General Permit, this General Permit shall be modified or revoked and reissued to conform to the toxic effluent standard or prohibition and the dischargers so notified.

C. Need to Halt or Reduce Activity Not a Defense

It shall not be a defense for a discharger in an enforcement action that it would have been necessary to halt or reduce the permitted activity in order to maintain compliance with the conditions of this General Permit.

D. Duty to Mitigate

The discharger shall take all responsible steps to minimize or prevent any discharge in violation of this General Permit, which has a reasonable likelihood of adversely affecting human health or the environment.

E. Proper Operation and Maintenance

The discharger shall at all times properly operate and maintain any facilities and systems of treatment and control (and related appurtenances) which are installed or used by the discharger to achieve compliance with the conditions of this General Permit. Proper operation and maintenance also includes adequate laboratory controls and appropriate quality assurance procedures. Proper operation and maintenance may require the operation of backup or auxiliary facilities or similar systems installed by a discharger when necessary to achieve compliance with the conditions of this General Permit.

F. Property Rights

This General Permit does not convey any property rights of any sort or any exclusive privileges, nor does it authorize any injury to private property or any invasion of personal rights, nor does it authorize any infringement of Federal, State, or local laws or regulations.

G. Duty to Maintain Records and Provide Information

1. The discharger shall maintain a paper or electronic copy of all required records, including a copy of this General Permit, for three years from the date generated or date submitted, whichever is last. These records shall be available at the construction site until construction is completed.
2. The discharger shall furnish the Regional Water Board, State Water Board, or U.S. EPA, within a reasonable time, any requested information to determine compliance with this General Permit. The discharger shall also furnish, upon request, copies of records that are required to be kept by this General Permit.

H. Inspection and Entry

The discharger shall allow the Regional Water Board, State Water Board, U.S. EPA, and/or, in the case of construction sites which discharge through a municipal separate storm sewer, an authorized representative of the municipal operator of the separate storm sewer system receiving the discharge, upon the presentation of credentials and other documents as may be required by law, to:

1. Enter upon the discharger's premises at reasonable times where a regulated construction activity is being conducted or where records must be kept under the conditions of this General Permit;

2. Access and copy at reasonable times any records that must be kept under the conditions of this General Permit;
3. Inspect at reasonable times the complete construction site, including any off-site staging areas or material storage areas, and the erosion/sediment controls; and
4. Sample or monitor at reasonable times for the purpose of ensuring General Permit compliance.

I. Electronic Signature and Certification Requirements

1. All Permit Registration Documents (PRDs) and Notice of Terminations (NOTs) shall be electronically signed, certified, and submitted via SMARTS to the State Water Board. Either the Legally Responsible Person (LRP) or a person legally authorized to sign and certify PRDs and NOTs on behalf of the LRP (the LRP's Approved Signatory) must submit all information electronically via SMARTS.
 - a. The LRP's Approved Signatory must be one of the following:
 - i. For a corporation: a responsible corporate officer. For the purpose of this section, a responsible corporate officer means: (a) a president, secretary, treasurer, or vice-president of the corporation in charge of a principal business function, or any other person who performs similar policy or decision-making functions for the corporation; or (b) the manager of the facility if authority to sign documents has been assigned or delegated to the manager in accordance with corporate procedures;
 - ii. For a partnership or sole proprietorship: a general partner or the proprietor, respectively;
 - iii. For a municipality, State, Federal, or other public agency: either a principal executive officer or ranking elected official. The principal executive officer of a Federal agency includes the chief executive officer of the agency or the senior executive officer having responsibility for the overall operations of a principal geographic unit of the agency (e.g., Regional Administrators of U.S. EPA);
 - iv. For the military: Any military officer who has been designated.
 - v. For a public university: An authorized university official

- b. Changes to Authorization. If an approved signatory's authorization is no longer accurate, a new authorization satisfying the requirements of paragraph (a) of this section must be submitted via SMARTS prior to or together with any reports, information or applications to be signed by an approved signatory.
2. All Annual Reports, or other information required by the General Permit (other than PRDs and NOTs) or requested by the Regional Water Board, State Water Board, U.S. EPA, or local storm water management agency shall be certified and submitted by the LRP or the LRP's approved signatory as described above.

J. Certification

Any person signing documents under Section IV.I above, shall make the following certification:

"I certify under penalty of law that this document and all attachments were prepared under my direction or supervision in accordance with a system designed to assure that qualified personnel properly gather and evaluate the information submitted. Based on my inquiry of the person or persons who manage the system or those persons directly responsible for gathering the information, to the best of my knowledge and belief, the information submitted is, true, accurate, and complete. I am aware that there are significant penalties for submitting false information, including the possibility of fine and imprisonment for knowing violations."

K. Anticipated Noncompliance

The discharger shall give advance notice to the Regional Water Board and local storm water management agency of any planned changes in the construction activity, which may result in noncompliance with General Permit requirements.

L. Bypass

Bypass⁸ is prohibited. The Regional Water Board may take enforcement action against the discharger for bypass unless:

1. Bypass was unavoidable to prevent loss of life, personal injury or severe property damage;⁹

⁸ The intentional diversion of waste streams from any portion of a treatment facility

⁹ Severe property damage means substantial physical damage to property, damage to the treatment facilities that causes them to become inoperable, or substantial and permanent loss of natural resources that can reasonably be expected to occur in the absence of a bypass. Severe property damage does not mean economic loss caused by delays in production.

2. There were no feasible alternatives to bypass, such as the use of auxiliary treatment facilities, retention of untreated waste, or maintenance during normal periods of equipment downtime. This condition is not satisfied if adequate back-up equipment should have been installed in the exercise of reasonable engineering judgment to prevent a bypass that could occur during normal periods of equipment downtime or preventative maintenance;
3. The discharger submitted a notice at least ten days in advance of the need for a bypass to the Regional Water Board; or
4. The discharger may allow a bypass to occur that does not cause effluent limitations to be exceeded, but only if it is for essential maintenance to assure efficient operation. In such a case, the above bypass conditions are not applicable. The discharger shall submit notice of an unanticipated bypass as required.

M. Upset

1. A discharger that wishes to establish the affirmative defense of an upset¹⁰ in an action brought for noncompliance shall demonstrate, through properly signed, contemporaneous operating logs, or other relevant evidence that:
 - a. An upset occurred and that the discharger can identify the cause(s) of the upset
 - b. The treatment facility was being properly operated by the time of the upset
 - c. The discharger submitted notice of the upset as required; and
 - d. The discharger complied with any remedial measures required
2. No determination made before an action of noncompliance occurs, such as during administrative review of claims that noncompliance was caused by an upset, is final administrative action subject to judicial review.
3. In any enforcement proceeding, the discharger seeking to establish the occurrence of an upset has the burden of proof

¹⁰ An exceptional incident in which there is unintentional and temporary noncompliance the technology based numeric effluent limitations because of factors beyond the reasonable control of the discharger. An upset does not include noncompliance to the extent caused by operational error, improperly designed treatment facilities, inadequate treatment facilities, lack of preventative maintenance, or careless or improper operation.

N. Penalties for Falsification of Reports

Section 309(c)(4) of the CWA provides that any person who knowingly makes any false material statement, representation, or certification in any record or other document submitted or required to be maintained under this General Permit, including reports of compliance or noncompliance shall upon conviction, be punished by a fine of not more than \$10,000 or by imprisonment for not more than two years or by both.

O. Oil and Hazardous Substance Liability

Nothing in this General Permit shall be construed to preclude the institution of any legal action or relieve the discharger from any responsibilities, liabilities, or penalties to which the discharger is or may be subject to under Section 311 of the CWA.

P. Severability

The provisions of this General Permit are severable; and, if any provision of this General Permit or the application of any provision of this General Permit to any circumstance is held invalid, the application of such provision to other circumstances and the remainder of this General Permit shall not be affected thereby.

Q. Reopener Clause

This General Permit may be modified, revoked and reissued, or terminated for cause due to promulgation of amended regulations, receipt of U.S. EPA guidance concerning regulated activities, judicial decision, or in accordance with 40 Code of Federal Regulations (CFR) 122.62, 122.63, 122.64, and 124.5.

R. Penalties for Violations of Permit Conditions

1. Section 309 of the CWA provides significant penalties for any person who violates a permit condition implementing Sections 301, 302, 306, 307, 308, 318, or 405 of the CWA or any permit condition or limitation implementing any such section in a permit issued under Section 402. Any person who violates any permit condition of this General Permit is subject to a civil penalty not to exceed \$37,500¹¹ per calendar day of such violation, as well as any other appropriate sanction provided by Section 309 of the CWA.

¹¹ May be further adjusted in accordance with the Federal Civil Penalties Inflation Adjustment Act.

2. The Porter-Cologne Water Quality Control Act also provides for civil and criminal penalties, which in some cases are greater than those under the CWA.

S. Transfers

This General Permit is not transferable.

T. Continuation of Expired Permit

This General Permit continues in force and effect until a new General Permit is issued or the SWRCB rescinds this General Permit. Only those dischargers authorized to discharge under the expiring General Permit are covered by the continued General Permit.

V. EFFLUENT STANDARDS

A. Narrative Effluent Limitations

1. Storm water discharges and authorized non-storm water discharges regulated by this General Permit shall not contain a hazardous substance equal to or in excess of reportable quantities established in 40 C.F.R. §§ 117.3 and 302.4, unless a separate NPDES Permit has been issued to regulate those discharges.
2. Dischargers shall minimize or prevent pollutants in storm water discharges and authorized non-storm water discharges through the use of controls, structures, and management practices that achieve BAT for toxic and non-conventional pollutants and BCT for conventional pollutants.

B. Numeric Effluent Limitations (NELs)

Table 1- Numeric Effluent Limitations, Numeric Action Levels, Test Methods, Detection Limits, and Reporting Units

Parameter	Test Method	Discharge Type	Min. Detection Limit	Units	Numeric Action Level	Numeric Effluent Limitation
pH	Field test with calibrated portable instrument	Risk Level 2	0.2	pH units	lower NAL = 6.5 upper NAL = 8.5	N/A
		Risk Level 3			lower NAL = 6.5 upper NAL = 8.5	lower NEL = 6.0 upper NEL = 9.0
Turbidity	EPA 0180.1 and/or field test with calibrated portable instrument	Risk Level 2	1	NTU	250 NTU	N/A
		Risk Level 3			250 NTU	500 NTU

1. Numeric Effluent Limitations (NELs):

- a. **Storm Event, Daily Average pH Limits** – For Risk Level 3 dischargers, the pH of storm water and non-storm water discharges

shall be within the ranges specified in Table 1 during any site phase where there is a "high risk of pH discharge."¹²

- b. **Storm Event Daily Average Turbidity Limit** – For Risk Level 3 dischargers, the turbidity of storm water and non-storm water discharges shall not exceed 500 NTU.
2. If daily average sampling results are outside the range of pH NELs (i.e., is below the lower NEL for pH or exceeds the upper NEL for pH) or exceeds the turbidity NEL (as listed in Table 1), the discharger is in violation of this General Permit and shall electronically file monitoring results in violation within 5 business days of obtaining the results.
3. **Compliance Storm Event:**

Discharges of storm water from Risk Level 3 sites shall comply with applicable NELs (above) unless the storm event causing the discharges is determined after the fact to be equal to or larger than the Compliance Storm Event (expressed in inches of rainfall). The Compliance Storm Event for Risk Level 3 discharges is the 5 year, 24 hour storm (expressed in tenths of an inch of rainfall), as determined by using these maps:

<http://www.wrcc.dri.edu/pcpnfreq/nca5y24.gif>
<http://www.wrcc.dri.edu/pcpnfreq/sca5y24.gif>

Compliance storm event verification shall be done by reporting on-site rain gauge readings as well as nearby governmental rain gauge readings.

4. Dischargers shall not be required to comply with NELs if the site receives run-on from a forest fire or any other natural disaster.

C. Numeric Action Levels (NALs)

1. For Risk Level 2 and 3 dischargers, the lower storm event average NAL for pH is 6.5 pH units and the upper storm event average NAL for pH is 8.5 pH units. The discharger shall take actions as described below if the discharge is outside of this range of pH values.

¹² A period of high risk of pH discharge is defined as a project's complete utilities phase, complete vertical build phase, and any portion of any phase where significant amounts of materials are placed directly on the land at the site in a manner that could result in significant alterations of the background pH of the discharges.

2. For Risk Level 2 and 3 dischargers, the NAL storm event daily average for turbidity is 250 NTU. The discharger shall take actions as described below if the discharge is outside of this range of turbidity values.
3. Whenever the results from a storm event daily average indicate that the discharge is below the lower NAL for pH, exceeds the upper NAL for pH, or exceeds the turbidity NAL (as listed in Table 1), the discharger shall conduct a construction site and run-on evaluation to determine whether pollutant source(s) associated with the site's construction activity may have caused or contributed to the NAL exceedance and shall immediately implement corrective actions if they are needed.
4. The site evaluation shall be documented in the SWPPP and specifically address whether the source(s) of the pollutants causing the exceedance of the NAL:
 - a. Are related to the construction activities and whether additional BMPs are required to (1) meet BAT/BCT requirements; (2) reduce or prevent pollutants in storm water discharges from causing exceedances of receiving water objectives; and (3) determine what corrective action(s) were taken or will be taken and with a description of the schedule for completion.

AND/OR:

- b. Are related to the run-on associated with the construction site location and whether additional BMPs measures are required to (1) meet BAT/BCT requirements; (2) reduce or prevent pollutants in storm water discharges from causing exceedances of receiving water objectives; and (3) what corrective action(s) were taken or will be taken with a description of the schedule for completion.

VI. RECEIVING WATER LIMITATIONS

- A.** The discharger shall ensure that storm water discharges and authorized non-storm water discharges to any surface or ground water will not adversely affect human health or the environment.
- B.** The discharger shall ensure that storm water discharges and authorized non-storm water discharges will not contain pollutants in quantities that threaten to cause pollution or a public nuisance.
- C.** The discharger shall ensure that storm water discharges and authorized non-storm water discharges will not contain pollutants that cause or contribute to an exceedance of any applicable water quality objectives or water quality standards (collectively, WQS) contained in a Statewide Water Quality Control Plan, the California Toxics Rule, the National Toxics Rule, or the applicable Regional Water Board's Water Quality Control Plan (Basin Plan).
- D.** Dischargers located within the watershed of a CWA § 303(d) impaired water body, for which a TMDL has been approved by the U.S. EPA, shall comply with the approved TMDL if it identifies "construction activity" or land disturbance as a source of the pollution.

VII. TRAINING QUALIFICATIONS AND CERTIFICATION REQUIREMENTS

A. General

The discharger shall ensure that all persons responsible for implementing requirements of this General Permit shall be appropriately trained in accordance with this Section. Training should be both formal and informal, occur on an ongoing basis, and should include training offered by recognized governmental agencies or professional organizations. Those responsible for preparing and amending SWPPPs shall comply with the requirements in this Section VII.

The discharger shall provide documentation of all training for persons responsible for implementing the requirements of this General Permit in the Annual Reports.

B. SWPPP Certification Requirements

1. **Qualified SWPPP Developer:** The discharger shall ensure that SWPPPs are written, amended and certified by a Qualified SWPPP Developer (QSD). A QSD shall have one of the following registrations or certifications, and appropriate experience, as required for:
 - a. A California registered professional civil engineer;
 - b. A California registered professional geologist or engineering geologist;
 - c. A California registered landscape architect;
 - d. A professional hydrologist registered through the American Institute of Hydrology;
 - e. A Certified Professional in Erosion and Sediment Control (CPESC)TM registered through Enviro Cert International, Inc.;
 - f. A Certified Professional in Storm Water Quality (CPSWQ)TM registered through Enviro Cert International, Inc.; or
 - g. A professional in erosion and sediment control registered through the National Institute for Certification in Engineering Technologies (NICET);

Effective two years after the adoption date of this General Permit, a QSD shall have attended a State Water Board-sponsored or approved QSD training course.

2. The discharger shall list the name and telephone number of the currently designated Qualified SWPPP Developer(s) in the SWPPP.
3. **Qualified SWPPP Practitioner:** The discharger shall ensure that all BMPs required by this General Permit are implemented by a Qualified SWPPP Practitioner (QSP). A QSP is a person responsible for non-storm water and storm water visual observations, sampling and analysis. Effective two years from the date of adoption of this General Permit, a QSP shall be either a QSD or have one of the following certifications:
 - a. A certified erosion, sediment and storm water inspector registered through Enviro Cert International, Inc.; or
 - b. A certified inspector of sediment and erosion control registered through Certified Inspector of Sediment and Erosion Control, Inc.

Effective two years after the adoption date of this General Permit, a QSP shall have attended a State Water Board-sponsored or approved QSP training course.

4. The LRP shall list in the SWPPP, the name of any Approved Signatory, and provide a copy of the written agreement or other mechanism that provides this authority from the LRP in the SWPPP.
5. The discharger shall include, in the SWPPP, a list of names of all contractors, subcontractors, and individuals who will be directed by the Qualified SWPPP Practitioner. This list shall include telephone numbers and work addresses. Specific areas of responsibility of each subcontractor and emergency contact numbers shall also be included.
6. The discharger shall ensure that the SWPPP and each amendment will be signed by the Qualified SWPPP Developer. The discharger shall include a listing of the date of initial preparation and the date of each amendment in the SWPPP.

VIII. RISK DETERMINATION

The discharger shall calculate the site's sediment risk and receiving water risk during periods of soil exposure (i.e. grading and site stabilization) and use the calculated risks to determine a Risk Level(s) using the methodology in

Appendix 1. For any site that spans two or more planning watersheds,¹³ the discharger shall calculate a separate Risk Level for each planning watershed. The discharger shall notify the State Water Board of the site's Risk Level determination(s) and shall include this determination as a part of submitting the PRDs. If a discharger ends up with more than one Risk Level determination, the Regional Water Board may choose to break the project into separate levels of implementation.

IX. RISK LEVEL 1 REQUIREMENTS

Risk Level 1 Dischargers shall comply with the requirements included in Attachment C of this General Permit.

X. RISK LEVEL 2 REQUIREMENTS

Risk Level 2 Dischargers shall comply with the requirements included in Attachment D of this General Permit.

XI. RISK LEVEL 3 REQUIREMENTS

Risk Level 3 Dischargers shall comply with the requirements included in Attachment E of this General Permit.

XII. ACTIVE TREATMENT SYSTEMS (ATS)

Dischargers choosing to implement an ATS on their site shall comply with all of the requirements in Attachment F of this General Permit.

¹³ Planning watershed: defined by the Calwater Watershed documents as a watershed that ranges in size from approximately 3,000 to 10,000 acres <http://cain.ice.ucdavis.edu/calwater/calwfaq.html>, <http://gis.ca.gov/catalog/BrowseRecord.epl?id=22175> .

XIII. POST-CONSTRUCTION STANDARDS

- A.** All dischargers shall comply with the following runoff reduction requirements unless they are located within an area subject to post-construction standards of an active Phase I or II municipal separate storm sewer system (MS4) permit that has an approved Storm Water Management Plan.
1. This provision shall take effect three years from the adoption date of this permit, or later at the discretion of the Executive Officer of the Regional Board.
 2. The discharger shall demonstrate compliance with the requirements of this section by submitting with their NOI a map and worksheets in accordance with the instructions in Appendix 2. The discharger shall use non-structural controls unless the discharger demonstrates that non-structural controls are infeasible or that structural controls will produce greater reduction in water quality impacts.
 3. The discharger shall, through the use of non-structural and structural measures as described in Appendix 2, replicate the pre-project water balance (for this permit, defined as the volume of rainfall that ends up as runoff) for the smallest storms up to the 85th percentile storm event (or the smallest storm event that generates runoff, whichever is larger). Dischargers shall inform Regional Water Board staff at least 30 days prior to the use of any structural control measure used to comply with this requirement. Volume that cannot be addressed using non-structural practices shall be captured in structural practices and approved by the Regional Water Board. When seeking Regional Board approval for the use of structural practices, dischargers shall document the infeasibility of using non-structural practices on the project site, or document that there will be fewer water quality impacts through the use of structural practices.
 4. For sites whose disturbed area exceeds two acres, the discharger shall preserve the pre-construction drainage density (miles of stream length per square mile of drainage area) for all drainage areas within the area serving a first order stream¹⁴ or larger stream and ensure that post-project time of runoff concentration is equal or greater than pre-project time of concentration.

¹⁴ A first order stream is defined as a stream with no tributaries.

- B.** All dischargers shall implement BMPs to reduce pollutants in storm water discharges that are reasonably foreseeable after all construction phases have been completed at the site (Post-construction BMPs).

XIV. SWPPP REQUIREMENTS

- A.** The discharger shall ensure that the Storm Water Pollution Prevention Plans (SWPPPs) for all traditional project sites are developed and amended or revised by a QSD. The SWPPP shall be designed to address the following objectives:
1. All pollutants and their sources, including sources of sediment associated with construction, construction site erosion and all other activities associated with construction activity are controlled;
 2. Where not otherwise required to be under a Regional Water Board permit, all non-storm water discharges are identified and either eliminated, controlled, or treated;
 3. Site BMPs are effective and result in the reduction or elimination of pollutants in storm water discharges and authorized non-storm water discharges from construction activity to the BAT/BCT standard;
 4. Calculations and design details as well as BMP controls for site run-on are complete and correct, and
 5. Stabilization BMPs installed to reduce or eliminate pollutants after construction are completed.
- B.** To demonstrate compliance with requirements of this General Permit, the QSD shall include information in the SWPPP that supports the conclusions, selections, use, and maintenance of BMPs.
- C.** The discharger shall make the SWPPP available at the construction site during working hours while construction is occurring and shall be made available upon request by a State or Municipal inspector. When the original SWPPP is retained by a crewmember in a construction vehicle and is not currently at the construction site, current copies of the BMPs and map/drawing will be left with the field crew and the original SWPPP shall be made available via a request by radio/telephone.

XV. REGIONAL WATER BOARD AUTHORITIES

- A.** In the case where the Regional Water Board does not agree with the discharger's self-reported risk level (e.g., they determine themselves to be a Level 1 Risk when they are actually a Level 2 Risk site), Regional Water Boards may either direct the discharger to reevaluate the Risk Level(s) for their site or terminate coverage under this General Permit.
- B.** Regional Water Boards may terminate coverage under this General Permit for dischargers who fail to comply with its requirements or where they determine that an individual NPDES permit is appropriate.
- C.** Regional Water Boards may require dischargers to submit a Report of Waste Discharge / NPDES permit application for Regional Water Board consideration of individual requirements.
- D.** Regional Water Boards may require additional Monitoring and Reporting Program Requirements, including sampling and analysis of discharges to sediment-impaired water bodies.
- E.** Regional Water Boards may require dischargers to retain records for more than the three years required by this General Permit.

XVI. ANNUAL REPORTING REQUIREMENTS

- A.** All dischargers shall prepare and electronically submit an Annual Report no later than September 1 of each year.
- B.** The discharger shall certify each Annual Report in accordance with the Special Provisions.
- C.** The discharger shall retain an electronic or paper copy of each Annual Report for a minimum of three years after the date the annual report is filed.
- D.** The discharger shall include storm water monitoring information in the Annual Report consisting of:
 - 1. a summary and evaluation of all sampling and analysis results, including copies of laboratory reports;
 - 2. the analytical method(s), method reporting unit(s), and method detection limit(s) of each analytical parameter (analytical results that are less than the method detection limit shall be reported as "less than the method detection limit");
 - 3. a summary of all corrective actions taken during the compliance year;
 - 4. identification of any compliance activities or corrective actions that were not implemented;
 - 5. a summary of all violations of the General Permit;
 - 6. the names of individual(s) who performed the facility inspections, sampling, visual observation (inspections), and/or measurements;
 - 7. the date, place, time of facility inspections, sampling, visual observation (inspections), and/or measurements, including precipitation (rain gauge); and
 - 8. the visual observation and sample collection exception records and reports specified in Attachments C, D, and E.
- E.** The discharger shall provide training information in the Annual Report consisting of:
 - 1. documentation of all training for individuals responsible for all activities associated with compliance with this General Permit;

2. documentation of all training for individuals responsible for BMP installation, inspection, maintenance, and repair; and
3. documentation of all training for individuals responsible for overseeing, revising, and amending the SWPPP.

**ATTACHMENT A
Linear Underground/ Overhead Requirements**

A. DEFINITION OF LINEAR UNDERGROUND/OVERHEAD PROJECTS 1
 B. LINEAR PROJECT PERMIT REGISTRATION DOCUMENTS (PRDs) 3
 C. LINEAR PROJECT TERMINATION OF COVERAGE REQUIREMENTS .. 4
 D. DISCHARGE PROHIBITIONS 6
 E. SPECIAL PROVISIONS..... 8
 F. EFFLUENT STANDARDS..... 13
 G. RECEIVING WATER LIMITATIONS 16
 H. TRAINING QUALIFICATIONS 17
 I. TYPES OF LINEAR PROJECTS 19
 J. LUP TYPE-SPECIFIC REQUIREMENTS 20
 K. STORM WATER POLLUTION PREVENTION PLAN (SWPPP) REQUIREMENTS 28
 L. REGIONAL WATER BOARD AUTHORITIES 29
 M. MONITORING AND REPORTING REQUIREMENTS 31

All Linear Underground/Overhead project dischargers who submit permit registration documents (PRDs) indicating their intention to be regulated under the provisions of this General Permit shall comply with the following:

A. DEFINITION OF LINEAR UNDERGROUND/OVERHEAD PROJECTS

1. Linear Underground/Overhead Projects (LUPs) include, but are not limited to, any conveyance, pipe, or pipeline for the transportation of any gaseous, liquid (including water and wastewater for domestic municipal services), liquescent, or slurry substance; any cable line or wire for the transmission of electrical energy; any cable line or wire for communications (e.g., telephone, telegraph, radio, or television messages); and associated ancillary facilities. Construction activities associated with LUPs include, but are not limited to, (a) those activities necessary for the installation of underground and overhead linear facilities (e.g., conduits, substructures, pipelines, towers, poles, cables, wires, connectors, switching, regulating and transforming equipment, and associated ancillary facilities); and include, but are not limited to, (b) underground utility mark-out, potholing, concrete and asphalt cutting and removal, trenching, excavation, boring and drilling, access road and pole/tower pad and cable/wire pull station, substation construction, substructure installation, construction of tower footings and/or foundations, pole and tower installations, pipeline installations, welding, concrete and/ or pavement repair or replacement, and stockpile/borrow locations.

2. LUP evaluation shall consist of two tasks:

- a. Confirm that the project or project section(s) qualifies as an LUP. The State Water Board website contains a project determination guidance flowchart.
http://www.waterboards.ca.gov/water_issues/programs/stormwater/constructionpermits.shtml
 - b. Identify which Type(s) (1, 2 or 3 described in Section I below) are applicable to the project or project sections based on project sediment and receiving water risk. (See Attachment A.1)
3. A Legally Responsible Person (LRP) for a Linear Underground/Overhead project is required to obtain CGP coverage under one or more permit registration document (PRD) electronic submittals to the State Water Board's Storm Water Multi-Application and Report Tracking (SMARTs) system. Attachment A.1 contains a flow chart to be used when determining if a linear project qualifies for coverage and to determine LUP Types. Since a LUP may be constructed within both developed and undeveloped locations and portions of LUPs may be constructed by different contractors, LUPs may be broken into logical permit sections. Sections may be determined based on portions of a project conducted by one contractor. Other situations may also occur, such as the time period in which the sections of a project will be constructed (e.g. project phases), for which separate permit coverage is possible. For projects that are broken into separate sections, a description of how each section relates to the overall project and the definition of the boundaries between sections shall be clearly stated.
 4. Where construction activities transverse or enter into different Regional Water Board jurisdictions, LRPs shall obtain permit coverage for each Regional Water Board area involved prior to the commencement of construction activities.
 5. Small Construction Rainfall Erosivity Waiver

EPA's Small Construction Erosivity Waiver applies to sites between one and five acres demonstrating that there are no adverse water quality impacts.

Dischargers eligible for a Rainfall Erosivity Waiver based on low erosivity potential shall complete the electronic Notice of Intent (NOI) and Sediment Risk form through the State Water Board's SMARTS system, certifying that the construction activity will take place during a period when the value of the rainfall erosivity factor is less than five. Where the LRP changes or another LRP is added during construction, the new LRP must also submit a waiver certification through the SMARTS system.

If a small linear construction site continues beyond the projected completion date given on the waiver certification, the LRP shall recalculate the rainfall erosivity factor for the new project duration and submit this information through the SMARTS system. If the new R factor is below five (5), the discharger shall update through SMARTS all applicable information on the waiver certification and retain a copy of the revised waiver onsite. The LRP shall submit the new waiver certification 30 days prior to the projected completion date listed on the original waiver form to assure exemption from permitting requirements is uninterrupted. If the new R factor is five (5) or above, the LRP shall be required to apply for coverage under this Order.

B. LINEAR PROJECT PERMIT REGISTRATION DOCUMENTS (PRDs)

Any information provided to the Regional Water Board shall comply with the Homeland Security Act and any other federal law that concerns security in the United States; any information that does not comply should not be submitted. PRDs shall consist of the following:

1. Notice of Intent (NOI)

Prior to construction activities, the LRP of a proposed linear underground/overhead project shall utilize the processes and methods provided in Attachment A.2, Permit Registration Documents (PRDs) – General Instructions for Linear Underground/Overhead Projects to comply with the Construction General Permit.

2. Site Maps

LRPs submitting PRDs shall include at least 3 maps. The first map will be a zoomed¹ 1000-1500 ft vicinity map that shows the starting point of the project. The second will be a zoomed map of 1000-1500 ft showing the ending location of the project. The third will be a larger view vicinity map, 1000 ft to 2000 ft, displaying the entire project location depending on the project size, and indicating the LUP type (1, 2 or 3) areas within the total project footprint.

3. Drawings

LRPs submitting PRDs shall include a construction drawing(s) or other appropriate drawing(s) or map(s) that shows the locations of storm drain

¹ An image with a close-up/enhanced detailed view of site features that show minute details such as streets and neighboring structures.

Or: An image with a close-up/enhanced detailed view of the site's surrounding infrastructure.

Or: An image with a close up detailed view of the project and its surroundings.

inlets and waterbodies² that may receive discharges from the construction activities and that shows the locations of BMPs to be installed for all those BMPs that can be illustrated on the revisable drawing(s) or map(s). If storm drain inlets, waterbodies, and/or BMPs cannot be adequately shown on the drawing(s) or map(s) they should be described in detail within the SWPPP.

4. Storm Water Pollution Prevention Plan (SWPPP)

LUP dischargers shall comply with the SWPPP Preparation, Implementation, and Oversight requirements in Section K of this Attachment.

5. Contact information

LUP dischargers shall include contact information for all contractors (or subcontractors) responsible for each area of an LUP project. This should include the names, telephone numbers, and addresses of contact personnel. Specific areas of responsibility of each contact, and emergency contact numbers should also be included.

6. In the case of a public emergency that requires immediate construction activities, a discharger shall submit a brief description of the emergency construction activity within five days of the onset of construction, and then shall submit all PRDs within thirty days.

C. LINEAR PROJECT TERMINATION OF COVERAGE REQUIREMENTS

The LRP may terminate coverage of an LUP when construction activities are completed by submitting an electronic notice of termination (NOT) through the State Water Board's SMARTS system. Termination requirements are different depending on the complexity of the LUP. An LUP is considered complete when: (a) there is no potential for construction-related storm water pollution; (b) all elements of the SWPPP have been completed; (c) construction materials and waste have been disposed of properly; (d) the site is in compliance with all local storm water management requirements; and (e) the LRP submits a notice of termination (NOT) and has received approval for termination from the appropriate Regional Water Board office.

1. LUP Stabilization Requirements

The LUP discharger shall ensure that all disturbed areas of the construction site are stabilized prior to termination of coverage under this General Permit. Final stabilization for the purposes of submitting an NOT

² Includes basin(s) that the MS4 storm sewer systems may drain to for Hydromodification or Hydrological Conditional of Concerns under the MS4 permits.

is satisfied when all soil disturbing activities are completed and one of the following criteria is met:

- a. In disturbed areas that were vegetated prior to construction activities of the LUP, the area disturbed must be re-established to a uniform vegetative cover equivalent to 70 percent coverage of the preconstruction vegetative conditions. Where preconstruction vegetation covers less than 100 percent of the surface, such as in arid areas, the 70 percent coverage criteria is adjusted as follows: if the preconstruction vegetation covers 50 percent of the ground surface, 70 percent of 50 percent ($.70 \times .50 = .35$) would require 35 percent total uniform surface coverage; or
- b. Where no vegetation is present prior to construction, the site is returned to its original line and grade and/or compacted to achieve stabilization; or
- c. Equivalent stabilization measures have been employed. These measures include, but are not limited to, the use of such BMPs as blankets, reinforced channel liners, soil cement, fiber matrices, geotextiles, or other erosion resistant soil coverings or treatments.

2. LUP Termination of Coverage Requirements

The LRP shall file an NOT through the State Water Board's SMARTS system. By submitting an NOT, the LRP is certifying that construction activities for an LUP are complete and that the project is in full compliance with requirements of this General Permit and that it is now compliant with soil stabilization requirements where appropriate. Upon approval by the appropriate Regional Water Board office, permit coverage will be terminated.

3. Revising Coverage for Change of Acreage

When the LRP of a portion of an LUP construction project changes, or when a phase within a multi-phase project is completed, the LRP may reduce the total acreage covered by this General Permit. In reducing the acreage covered by this General Permit, the LRP shall electronically file revisions to the PRDs that include:

- a. a revised NOI indicating the new project size;
- b. a revised site map showing the acreage of the project completed, acreage currently under construction, acreage sold, transferred or added, and acreage currently stabilized.
- c. SWPPP revisions, as appropriate; and
- d. certification that any new LRPs have been notified of applicable requirements to obtain General Permit coverage. The certification shall include the name, address, telephone number, and e-mail address (if known) of the new LRP.

If the project acreage has increased, dischargers shall mail payment of revised annual fees within 14 days of receiving the revised annual fee notification.

D. DISCHARGE PROHIBITIONS

1. LUP dischargers shall not violate any discharge prohibitions contained in applicable Basin Plans or statewide water quality control plans. Waste discharges to Areas of Special Biological Significance (ASBS) are prohibited by the California Ocean Plan, unless granted an exception issued by the State Water Board.
2. LUP dischargers are prohibited from discharging non-storm water that is not otherwise authorized by this General Permit. Non-storm water discharges authorized by this General Permit³ may include, fire hydrant flushing, irrigation of vegetative erosion control measures, pipe flushing and testing, water to control dust, street cleaning, dewatering,⁴ uncontaminated groundwater from dewatering, and other discharges not subject to a separate general NPDES permit adopted by a Regional Water Board. Such discharges are allowed by this General Permit provided they are not relied upon to clean up failed or inadequate construction or post-construction BMPs designed to keep materials on site. These authorized non-storm water discharges:

³ Dischargers must identify all authorized non-storm water discharges in the LUP's SWPPP and identify BMPs that will be implemented to either eliminate or reduce pollutants in non-storm water discharges. Regional Water Boards may direct the discharger to discontinue discharging such non-storm water discharges if determined that such discharges discharge significant pollutants or threaten water quality.

⁴Dewatering activities may be prohibited or need coverage under a separate permit issued by the Regional Water Boards. Dischargers shall check with the appropriate Regional Water Boards for any required permit or basin plan conditions prior to initial dewatering activities to land, storm drains, or waterbodies.

- a. Shall not cause or contribute to a violation of any water quality standard;
- b. Shall not violate any other provision of this General Permit;
- c. Shall not violate any applicable Basin Plan;
- d. Shall comply with BMPs as described in the SWPPP;
- e. Shall not contain toxic constituents in toxic amounts or (other) significant quantities of pollutants;
- f. Shall be monitored and meets the applicable NALs and NELs; and
- g. Shall be reported by the discharger in the Annual Report.

If any of the above conditions are not satisfied, the discharge is not authorized by this General Permit. The discharger shall notify the Regional Water Board of any anticipated non-storm water discharges not authorized by this General Permit to determine the need for a separate NPDES permit.

Additionally, some LUP dischargers may be required to obtain a separate permit if the applicable Regional Water Board has adopted a General Permit for dewatering discharges. Wherever feasible, alternatives, that do not result in the discharge of non-storm water, shall be implemented in accordance with this Attachment's Section K.2 - SWPPP Implementation Schedule.

3. LUP dischargers shall ensure that trench spoils or any other soils disturbed during construction activities that are contaminated⁵ are not discharged with storm water or non-storm water discharges into any storm drain or water body except pursuant to an NPDES permit.

When soil contamination is found or suspected and a responsible party is not identified, or the responsible party fails to promptly take the appropriate action, the LUP discharger shall have those soils sampled and tested to ensure that proper handling and public safety measures are

⁵ Contaminated soil contains pollutants in concentrations that exceed the appropriate thresholds that various regulatory agencies set for those substances. Preliminary testing of potentially contaminated soils will be based on odor, soil discoloration, or prior history of the site's chemical use and storage and other similar factors. When soil contamination is found or suspected and a responsible party is not identified, or the responsible party fails to promptly take the appropriate action, the discharger shall have those soils sampled and tested to ensure proper handling and public safety measures are implemented. The legally responsible person will notify the appropriate local, State, or federal agency(ies) when contaminated soil is found at a construction site, and will notify the Regional Water Board by submitting an NOT at the completion of the project.

implemented. The LUP discharger shall notify the appropriate local, State, and federal agency(ies) when contaminated soil is found at a construction site, and will notify the appropriate Regional Water Board.

4. Discharging any pollutant-laden water that will cause or contribute to an exceedance of the applicable Regional Water Board's Basin Plan from a dewatering site or sediment basin into any receiving water or storm drain is prohibited.
5. Debris⁶ resulting from construction activities are prohibited from being discharged from construction project sites.

E. SPECIAL PROVISIONS

1. Duty to Comply

- a. The LUP discharger must comply with all of the conditions of this General Permit. Any permit noncompliance constitutes a violation of the Clean Water Act (CWA) and the Porter-Cologne Water Quality Control Act and is grounds for enforcement action and/or removal from General Permit coverage.
- b. The LUP discharger shall comply with effluent standards or prohibitions established under Section 307(a) of the CWA for toxic pollutants within the time provided in the regulations that establish these standards or prohibitions, even if this General Permit has not yet been modified to incorporate the requirement.

2. General Permit Actions

- a. This General Permit may be modified, revoked and reissued, or terminated for cause. The filing of a request by the discharger for a General Permit modification, revocation and reissuance, or termination, or a notification of planned changes or anticipated noncompliance does not annul any General Permit condition.

⁶ Litter, rubble, discarded refuse, and remains of something destroyed.

- b. If any toxic effluent standard or prohibition (including any schedule of compliance specified in such effluent standard or prohibition) is promulgated under Section 307(a) of the CWA for a toxic pollutant which is present in the discharge and that standard or prohibition is more stringent than any limitation on the pollutant in this General Permit, this General Permit shall be modified or revoked and reissued to conform to the toxic effluent standard or prohibition and the dischargers so notified.

3. Need to Halt or Reduce Activity Not a Defense

It shall not be a defense for an LUP discharger in an enforcement action that it would have been necessary to halt or reduce the permitted activity in order to maintain compliance with the conditions of this General Permit.

4. Duty to Mitigate

The LUP discharger shall take all responsible steps to minimize or prevent any discharge in violation of this General Permit, which has a reasonable likelihood of adversely affecting human health or the environment.

5. Proper Operation and Maintenance

The LUP discharger shall at all times properly operate and maintain any facilities and systems of treatment and control (and related appurtenances) which are installed or used by the discharger to achieve compliance with the conditions of this General Permit and with the requirements of the Storm Water Pollution Prevention Plan (SWPPP). Proper operation and maintenance also includes adequate laboratory controls and appropriate quality assurance procedures. Proper operation and maintenance may require the operation of backup or auxiliary facilities or similar systems installed by a discharger when necessary to achieve compliance with the conditions of this General Permit.

6. Property Rights

This General Permit does not convey any property rights of any sort or any exclusive privileges, nor does it authorize any injury to private property or any invasion of personal rights, nor does it authorize any infringement of Federal, State, or local laws or regulations.

7. Duty to Maintain Records and Provide Information

- a. The LUP discharger shall maintain a paper or electronic copy of all required records, including a copy of this General Permit, for three years from the date generated or date submitted, whichever is last. These records shall be kept at the construction site or in a crew

member's vehicle until construction is completed, and shall be made available upon request.

- b. The LUP discharger shall furnish the Regional Water Board, State Water Board, or USEPA, within a reasonable time, any requested information to determine compliance with this General Permit. The LUP discharger shall also furnish, upon request, copies of records that are required to be kept by this General Permit.

8. Inspection and Entry

The LUP discharger shall allow the Regional Water Board, State Water Board, USEPA, and/or, in the case of construction sites which discharge through a municipal separate storm sewer, an authorized representative of the municipal operator of the separate storm sewer system receiving the discharge, upon the presentation of credentials and other documents as may be required by law, to:

- a. Enter upon the discharger's premises at reasonable times where a regulated construction activity is being conducted or where records must be kept under the conditions of this General Permit;
- b. Access and copy at reasonable times any records that must be kept under the conditions of this General Permit;
- c. Inspect at reasonable times the complete construction site, including any off-site staging areas or material storage areas, and the erosion/sediment controls; and
- d. Sample or monitor at reasonable times for the purpose of ensuring General Permit compliance.

9. Electronic Signature and Certification Requirements

- a. All Permit Registration Documents (PRDs) and Notices of Termination (NOTs) shall be electronically signed, certified, and submitted via SMARTS to the State Water Board. Either the Legally Responsible Person (LRP) or a person legally authorized to sign and certify PRDs and NOTs on behalf of the LRP (the LRP's Approved Signatory) must submit all information electronically via SMARTS. For Linear Underground/Overhead projects, the Legally Responsible Person is the person in charge of the utility company, municipality, or other public or private company or agency that owns or operates the LUP. The LRP's Approved Signatory must be one of the following:
 - i For a corporation: a responsible corporate officer. For the purpose of this section, a responsible corporate officer means:

- (1) a president, secretary, treasurer, or vice-president of the corporation in charge of a principal business function, or any other person who performs similar policy or decision-making functions for the corporation; or
 - (2) the manager of the facility if authority to sign documents has been assigned or delegated to the manager in accordance with corporate procedures;
 - ii For a partnership or sole proprietorship: a general partner or the proprietor, respectively; or
 - iii For a municipality, State, Federal, or other public agency: either a principal executive officer or ranking elected official. The principal executive officer of a Federal agency includes the chief executive officer of the agency or the senior executive officer having responsibility for the overall operations of a principal geographic unit of the agency (e.g., Regional Administrators of U.S. EPA).
- b. Changes to Authorization. If an approved signatory's authorization is no longer accurate, a new authorization satisfying the requirements of paragraph (a) of this section must be submitted via SMARTS prior to or together with any reports, information or applications to be signed by an approved signatory.
- c. All SWPPP revisions, annual reports, or other information required by the General Permit (other than PRDs and NOTs) or requested by the Regional Water Board, State Water Board, USEPA, or local storm water management agency shall be certified and submitted by the LRP or the LRP's approved signatory as described above.

10. Certification

Any person signing documents under Section E.9 above, shall make the following certification:

"I certify under penalty of law that this document and all attachments were prepared under my direction or supervision in accordance with a system designed to assure that qualified personnel properly gather and evaluate the information submitted. Based on my inquiry of the person or persons who manage the system or those persons directly responsible for gathering the information, to the best of my knowledge and belief, the information submitted is, true, accurate, and complete. I am aware that there are significant penalties for submitting false information, including the possibility of fine and imprisonment for knowing violations."

11. Anticipated Noncompliance

The LUP discharger shall give advance notice to the Regional Water Board and local storm water management agency of any planned changes in the construction activity, which may result in noncompliance with General Permit requirements.

12. Penalties for Falsification of Reports

Section 309(c)(4) of the CWA provides that any person who knowingly makes any false material statement, representation, or certification in any record or other document submitted or required to be maintained under this General Permit, including reports of compliance or noncompliance shall upon conviction, be punished by a fine of not more than \$10,000 or by imprisonment for not more than two years or by both.

13. Oil and Hazardous Substance Liability

Nothing in this General Permit shall be construed to preclude the institution of any legal action or relieve the discharger from any responsibilities, liabilities, or penalties to which the LUP discharger is or may be subject to under Section 311 of the CWA.

14. Severability

The provisions of this General Permit are severable; and, if any provision of this General Permit or the application of any provision of this General Permit to any circumstance is held invalid, the application of such provision to other circumstances and the remainder of this General Permit shall not be affected thereby.

15. Reopener Clause

This General Permit may be modified, revoked and reissued, or terminated for cause due to promulgation of amended regulations, receipt of USEPA guidance concerning regulated activities, judicial decision, or in accordance with 40 Code of Federal Regulations (CFR) 122.62, 122.63, 122.64, and 124.5.

16. Penalties for Violations of Permit Conditions

- a. Section 309 of the CWA provides significant penalties for any person who violates a permit condition implementing Sections 301, 302, 306, 307, 308, 318, or 405 of the CWA or any permit condition or limitation implementing any such section in a permit issued under Section 402. Any person who violates any permit condition of this General Permit is

subject to a civil penalty not to exceed \$37,500⁷ per calendar day of such violation, as well as any other appropriate sanction provided by Section 309 of the CWA.

- b. The Porter-Cologne Water Quality Control Act also provides for civil and criminal penalties, which in some cases are greater than those under the CWA.

17. Transfers

This General Permit is not transferable. A new LRP of an ongoing construction activity must submit PRDs in accordance with the requirements of this General Permit to be authorized to discharge under this General Permit. An LRP who is a property owner with active General Permit coverage who sells a fraction or all the land shall inform the new property owner(s) of the requirements of this General Permit.

18. Continuation of Expired Permit

This General Permit continues in force and effect until a new General Permit is issued or the SWRCB rescinds this General Permit. Only those dischargers authorized to discharge under the expiring General Permit are covered by the continued General Permit.

F. EFFLUENT STANDARDS

1. Narrative Effluent Limitations

- a. LUP dischargers shall ensure that storm water discharges and authorized non-storm water discharges regulated by this General Permit do not contain a hazardous substance equal to or in excess of reportable quantities established in 40 C.F.R. §§ 117.3 and 302.4, unless a separate NPDES Permit has been issued to regulate those discharges.
- b. LUP dischargers shall minimize or prevent pollutants in storm water discharges and authorized non-storm water discharges through the use of structural or non-structural controls, structures, and management practices that achieve BAT for toxic and non-conventional pollutants and BCT for conventional pollutants.

⁷ May be further adjusted in accordance with the Federal Civil Penalties Inflation Adjustment Act

2. Numeric Effluent Limitations (NELs)

Table 1. Numeric Effluent Limitations, Numeric Action Levels, Test Methods, Detection Limits, and Reporting Units

Parameter	Test Method	Discharge Type	Min. Detection Limit	Units	Numeric Action Level	Numeric Effluent Limitation
pH	Field test with calibrated portable instrument	LUP Type 2	0.2	pH units	lower NAL = 6.5 upper NAL = 8.5	N/A
		LUP Type 3			lower NAL = 6.5 upper NAL = 8.5	lower NEL = 6.0 upper NEL = 9.0
Turbidity EPA	0180.1 and/or field test with calibrated portable instrument	LUP Type 2	1 NTU		250 NTU	N/A
		LUP Type 3			250 NTU	500 NTU

a. Numeric Effluent Limitations (NELs):

- i **Storm Event, Daily Average pH Limits** – For LUP Type 3 dischargers, the daily average pH of storm water and non-storm water discharges shall be within the ranges specified in Table 1 during any project phase where there is a "high risk of pH discharge."⁸
- ii **Storm Event Daily Average Turbidity Limit** – For LUP Type 3 dischargers, the daily average turbidity of storm water and non-storm water discharges shall not exceed 500 NTU.

⁸ A period of high risk of pH discharge is defined as a project's complete utilities phase, complete vertical build phase, and any portion of any phase where significant amounts of materials are placed directly on the land at the site in a manner that could result in significant alterations of the background pH of the discharges.

- b. If a daily average sample result is outside the range of pH NELs (i.e., is below the lower NEL for pH or exceeds the upper NEL for pH) or exceeds the turbidity NEL (as listed in Table 1), the discharger is in violation of this General Permit and shall electronically file the results in violation within 5 business days of obtaining the results.

- c. Compliance Storm Event:

Discharges of storm water from LUP Type 3 sites shall comply with applicable NELs (above) unless the storm event causing the discharges is determined after the fact to be equal to or larger than the Compliance Storm Event (expressed in inches of rainfall). The Compliance Storm Event for LUP Type 3 discharges is the 5-year, 24-hour storm (expressed in tenths of an inch of rainfall), as determined by using these maps:

<http://www.wrcc.dri.edu/pcpnfreq/nca5y24.gif>

<http://www.wrcc.dri.edu/pcpnfreq/sca5y24.gif>

Compliance storm event verification shall be done by reporting on-site rain gauge readings as well as nearby governmental rain gauge readings.

- d. Dischargers shall not be required to comply with NELs if the site receives run-on from a forest fire or any other natural disaster.

3. Numeric Action Levels (NALs)

- a. For LUP Type 2 and 3 dischargers, the lower storm event daily average NAL for pH is 6.5 pH units and the upper storm event daily average NAL for pH is 8.5 pH units. The LUP discharger shall take actions as described below if the storm event daily average discharge is outside of this range of pH values.
- b. For LUP Type 2 and 3 dischargers, the storm event daily average NAL for turbidity is 250 NTU. The discharger shall take actions as described below if the storm event daily average discharge is outside of this range of turbidity values.
- c. Whenever daily average analytical effluent monitoring results indicate that the discharge is below the lower NAL for pH, exceeds the upper NAL for pH, or exceeds the turbidity NAL (as listed in Table 1), the LUP discharger shall conduct a construction site and run-on evaluation to determine whether pollutant source(s) associated with the site's construction activity may have caused or contributed to the NAL

exceedance and shall immediately implement corrective actions if they are needed.

- d. The site evaluation will be documented in the SWPPP and specifically address whether the source(s) of the pollutants causing the exceedance of the NAL:
 - i. Are related to the construction activities and whether additional BMPs or SWPPP implementation measures are required to (1) meet BAT/BCT requirements; (2) reduce or prevent pollutants in storm water discharges from causing exceedances of receiving water objectives; and (3) determine what corrective action(s) were taken or will be taken and with a description of the schedule for completion.

AND/OR:

- ii. Are related to the run-on associated with the construction site location and whether additional BMPs or SWPPP implementation measures are required to (1) meet BAT/BCT requirements; (2) reduce or prevent pollutants in storm water discharges from causing exceedances of receiving water objectives; and (3) decide what corrective action(s) were taken or will be taken, including a description of the schedule for completion.

G. RECEIVING WATER LIMITATIONS

1. LUP dischargers shall ensure that storm water discharges and authorized non-storm water discharges to any surface or ground water will not adversely affect human health or the environment.
2. LUP dischargers shall ensure that storm water discharges and authorized non-storm water discharges will not contain pollutants in quantities that threaten to cause pollution or a public nuisance.
3. LUP dischargers shall ensure that storm water discharges and authorized non-storm water discharges will not contain pollutants that cause or contribute to an exceedance of any applicable water quality objectives or water quality standards (collectively, WQS) contained in a Statewide Water Quality Control Plan, the California Toxics Rule, the National Toxics Rule, or the applicable Regional Water Board's Water Quality Control Plan (Basin Plan).

H. TRAINING QUALIFICATIONS

1. General

All persons responsible for implementing requirements of this General Permit shall be appropriately trained. Training should be both formal and informal, occur on an ongoing basis, and should include training offered by recognized governmental agencies or professional organizations. Persons responsible for preparing, amending and certifying SWPPPs shall comply with the requirements in this Section H.

2. SWPPP Certification Requirements

- a. **Qualified SWPPP Developer:** The LUP discharger shall ensure that all SWPPPs be written, amended and certified by a Qualified SWPPP Developer (QSD). A QSD shall have one of the following registrations or certifications, and appropriate experience, as required for:
 - i A California registered professional civil engineer;
 - ii A California registered professional geologist or engineering geologist;
 - iii A California registered landscape architect;
 - iv A professional hydrologist registered through the American Institute of Hydrology;
 - v A certified professional in erosion and sediment control (CPESC)™ registered through Enviro Cert International, Inc;
 - vi A certified professional in storm water quality (CPSWQ)™ registered through Enviro Cert International, Inc.; or
 - vii A certified professional in erosion and sediment control registered through the National Institute for Certification in Engineering Technologies (NICET).

Effective two years after the adoption date of this General Permit, a QSD shall have attended a State Water Board-sponsored or approved QSD training course.

- b. The LUP discharger shall ensure that the SWPPP is written and amended, as needed, to address the specific circumstances for each construction site covered by this General Permit prior to commencement of construction activity for any stage.
- c. The LUP discharger shall list the name and telephone number of the currently designated Qualified SWPPP Developer(s) in the SWPPP.
- d. **Qualified SWPPP Practitioner:** The LUP discharger shall ensure that all elements of any SWPPP for each project will be implemented by a Qualified SWPPP Practitioner (QSP). A QSP is a person responsible for non-storm water and storm water visual observations, sampling and analysis, and for ensuring full compliance with the permit and implementation of all elements of the SWPPP. Effective two years from the date of adoption of this General Permit, a QSP shall be either a QSD or have one of the following certifications:
 - i. A certified erosion, sediment and storm water inspector registered through Certified Professional in Erosion and Sediment Control, Inc.; or
 - ii. A certified inspector of sediment and erosion control registered through Certified Inspector of Sediment and Erosion Control, Inc.Effective two years after the adoption date of this General Permit, a QSP shall have attended a State Water Board-sponsored or approved QSP training course.
- e. The LUP discharger shall ensure that the SWPPP include a list of names of all contractors, subcontractors, and individuals who will be directed by the Qualified SWPPP Practitioner, and who is ultimately responsible for implementation of the SWPPP. This list shall include telephone numbers and work addresses. Specific areas of responsibility of each subcontractor and emergency contact numbers shall also be included.
- f. The LUP discharger shall ensure that the SWPPP and each amendment be signed by the Qualified SWPPP Developer. The LUP discharger shall include a listing of the date of initial preparation and the dates of each amendment in the SWPPP.

I. TYPES OF LINEAR PROJECTS

This attachment establishes three types (Type 1, 2 & 3) of complexity for areas within an LUP or project section based on threat to water quality. Project area Types are determined through Attachment A.1.

The Type 1 requirements below establish the baseline requirements for all LUPs subject to this General Permit. Additional requirements for Type 2 and Type 3 LUPs are labeled.

1. Type 1 LUPs:

LUP dischargers with areas of a LUP designated as Type 1 shall comply with the requirements in this Attachment. Type 1 LUPs are:

- a. Those construction areas where 70 percent or more of the construction activity occurs on a paved surface and where areas disturbed during construction will be returned to preconstruction conditions or equivalent protection established at the end of the construction activities for the day; or
- b. Where greater than 30 percent of construction activities occur within the non-paved shoulders or land immediately adjacent to paved surfaces, or where construction occurs on unpaved improved roads, including their shoulders or land immediately adjacent to them where:
 - i. Areas disturbed during construction will be returned to preconstruction conditions or equivalent protection is established at the end of the construction activities for the day to minimize the potential for erosion and sediment deposition, and
 - ii. Areas where established vegetation was disturbed during construction will be stabilized and re-vegetated by the end of project. When required, adequate temporary stabilization BMPs will be installed and maintained until vegetation is established to meet minimum cover requirements established in this General Permit for final stabilization.
- c. Where the risk determination is as follows:
 - i. Low sediment risk, low receiving water risk, or
 - ii. Low sediment risk, medium receiving water risk, or
 - iii. Medium sediment risk, low receiving water risk

2. Type 2 LUPs:

Type 2 LUPs are determined by the Combined Risk Matrix in Attachment A.1. Type 2 LUPs have the specified combination of risk:

- d. High sediment risk, low receiving water risk, or
- e. Medium sediment risk, medium receiving water risk, or
- f. Low sediment risk, high receiving water risk

Receiving water risk is either considered “Low” for those areas of the project that are not in close proximity to a sensitive receiving watershed, “Medium” for those areas of the project within a sensitive receiving watershed yet outside of the flood plain of a sensitive receiving water body, and “High” where the soil disturbance is within close proximity to a sensitive receiving water body. Project sediment risk is calculated based on the Risk Factor Worksheet in Attachment C of this General Permit.

3. Type 3 LUPs:

Type 3 LUPs are determined by the Combined Risk Matrix in Attachment A.1. Type 3 LUPs have the specified combination of risk:

- a. High sediment risk, high receiving water risk, or
- b. High sediment risk, medium receiving water risk, or
- c. Medium sediment risk, high receiving water risk

Receiving water risk is either considered “Medium” for those areas of the project within a sensitive receiving watershed yet outside of the flood plain of a sensitive receiving water body, or “High” where the soil disturbance is within close proximity to a sensitive receiving water body. Project sediment risk is calculated based on the Risk Factor Worksheet in Attachment C.

J. LUP TYPE-SPECIFIC REQUIREMENTS**1. Effluent Standards**

- a. Narrative – LUP dischargers shall comply with the narrative effluent standards below.

- i Storm water discharges and authorized non-storm water discharges regulated by this General Permit shall not contain a hazardous substance equal to or in excess of reportable quantities established in 40 C.F.R. §§ 117.3 and 302.4, unless a separate NPDES Permit has been issued to regulate those discharges.
 - ii LUP dischargers shall minimize or prevent pollutants in storm water discharges and authorized non-storm water discharges through the use of controls, structures, and management practices that achieve BAT for toxic and non-conventional pollutants and BCT for conventional pollutants.
- b. Numeric – LUP Type 1 dischargers are not subject to a numeric effluent standard
 - c. Numeric –LUP Type 2 dischargers are subject to a pH NAL of 6.5-8.5, and a turbidity NAL of 250 NTU.
 - d. Numeric – LUP Type 3 dischargers are subject to a pH NAL of 6.5-8.5, and a turbidity NAL of 250 NTU. In addition, LUP Type 3 dischargers are subject to a pH NEL of 6.0-9.0 and a turbidity NEL of 500 NTU.

2. Good Site Management "Housekeeping"

- a. LUP dischargers shall implement good site management (i.e., "housekeeping") measures for construction materials that could potentially be a threat to water quality if discharged. At a minimum, the good housekeeping measures shall consist of the following:
 - i Identify the products used and/or expected to be used and the end products that are produced and/or expected to be produced. This does not include materials and equipment that are designed to be outdoors and exposed to environmental conditions (i.e. poles, equipment pads, cabinets, conductors, insulators, bricks, etc.).
 - ii Cover and berm loose stockpiled construction materials that are not actively being used (i.e. soil, spoils, aggregate, fly-ash, stucco, hydrated lime, etc.).
 - iii Store chemicals in watertight containers (with appropriate secondary containment to prevent any spillage or leakage) or in a storage shed (completely enclosed).
 - iv Minimize exposure of construction materials to precipitation (not applicable to materials designed to be outdoors and exposed to the environment).

- v Implement BMPs to control the off-site tracking of loose construction and landscape materials.
- b. LUP dischargers shall implement good housekeeping measures for waste management, which, at a minimum, shall consist of the following:
 - i Prevent disposal of any rinse or wash waters or materials on impervious or pervious site surfaces or into the storm drain system.
 - ii Ensure the containment of sanitation facilities (e.g., portable toilets) to prevent discharges of pollutants to the storm water drainage system or receiving water.
 - iii Clean or replace sanitation facilities and inspecting them regularly for leaks and spills.
 - iv Cover waste disposal containers at the end of every business day and during a rain event.
 - v Prevent discharges from waste disposal containers to the storm water drainage system or receiving water.
 - vi Contain and securely protect stockpiled waste material from wind and rain at all times unless actively being used.
 - vii Implement procedures that effectively address hazardous and non-hazardous spills.
 - viii Develop a spill response and implementation element of the SWPPP prior to commencement of construction activities. The SWPPP shall require that:
 - (1) Equipment and materials for cleanup of spills shall be available on site and that spills and leaks shall be cleaned up immediately and disposed of properly; and
 - (2) Appropriate spill response personnel are assigned and trained.
 - ix Ensure the containment of concrete washout areas and other washout areas that may contain additional pollutants so there is no discharge into the underlying soil and onto the surrounding areas.

- c. LUP dischargers shall implement good housekeeping for vehicle storage and maintenance, which, at a minimum, shall consist of the following:
- i Prevent oil, grease, or fuel from leaking into the ground, storm drains or surface waters.
 - ii Implement appropriate BMPs whenever equipment or vehicles are fueled, maintained or stored.
 - iii Clean leaks immediately and disposing of leaked materials properly.
- d. LUP dischargers shall implement good housekeeping for landscape materials, which, at a minimum, shall consist of the following:
- i Contain stockpiled materials such as mulches and topsoil when they are not actively being used.
 - ii Contain fertilizers and other landscape materials when they are not actively being used.
 - iii Discontinue the application of any erodible landscape material at least 2 days before a forecasted rain event⁹ or during periods of precipitation.
 - iv Applying erodible landscape material at quantities and application rates according to manufacture recommendations or based on written specifications by knowledgeable and experienced field personnel.
 - v Stacking erodible landscape material on pallets and covering or storing such materials when not being used or applied.
- e. LUP dischargers shall conduct an assessment and create a list of potential pollutant sources and identify any areas of the site where additional BMPs are necessary to reduce or prevent pollutants in storm water discharges and authorized non-storm water discharges. This potential pollutant list shall be kept with the SWPPP and shall identify all non-visible pollutants which are known, or should be known, to occur on the construction site. At a minimum, when developing BMPs, LUP dischargers shall do the following:

⁹ 50% or greater chance of producing precipitation.

- i Consider the quantity, physical characteristics (e.g., liquid, powder, solid), and locations of each potential pollutant source handled, produced, stored, recycled, or disposed of at the site.
 - ii Consider the degree to which pollutants associated with those materials may be exposed to and mobilized by contact with storm water.
 - iii Consider the direct and indirect pathways that pollutants may be exposed to storm water or authorized non-storm water discharges. This shall include an assessment of past spills or leaks, non-storm water discharges, and discharges from adjoining areas.
 - iv Ensure retention of sampling, visual observation, and inspection records.
 - v Ensure effectiveness of existing BMPs to reduce or prevent pollutants in storm water discharges and authorized non-storm water discharges.
- f. LUP dischargers shall implement good housekeeping measures on the construction site to control the air deposition of site materials and from site operations.

3. Non-Storm Water Management

- a. LUP dischargers shall implement measures to control all non-storm water discharges during construction.
- b. LUP dischargers shall wash vehicles in such a manner as to prevent non-storm water discharges to surface waters or MS4 drainage systems.
- c. LUP dischargers shall clean streets in such a manner as to prevent unauthorized non-storm water discharges from reaching surface water or MS4 drainage systems.

4. Erosion Control

- a. LUP dischargers shall implement effective wind erosion control.
- b. LUP dischargers shall provide effective soil cover for inactive¹⁰ areas and all finished slopes, and utility backfill.

¹⁰ Areas of construction activity that have been disturbed and are not scheduled to be re-disturbed for at least 14 days

- c. LUP dischargers shall limit the use of plastic materials when more sustainable, environmentally friendly alternatives exist. Where plastic materials are deemed necessary, the discharger shall consider the use of plastic materials resistant to solar degradation.

5. Sediment Controls

- a. LUP dischargers shall establish and maintain effective perimeter controls as needed, and implement effective BMPs for all construction entrances and exits to sufficiently control erosion and sediment discharges from the site.
- b. On sites where sediment basins are to be used, LUP dischargers shall, at minimum, design sediment basins according to the guidance provided in CASQA’s Construction BMP Handbook.
- c. **Additional LUP Type 2 & 3 Requirement:** LUP Type 2 & 3 dischargers shall apply linear sediment controls along the toe of the slope, face of the slope, and at the grade breaks of exposed slopes to comply with sheet flow lengths¹¹ in accordance with Table 2 below.

Table 2 – Critical Slope/Sheet Flow Length Combinations

Slope Percentage	Sheet flow length not to exceed
0-25% 20	feet
25-50% 15	feet
Over 50%	10 feet

- d. **Additional LUP Type 2 & 3 Requirement:** LUP Type 2 & 3 dischargers shall ensure that construction activity traffic to and from the project is limited to entrances and exits that employ effective controls to prevent off-site tracking of sediment.
- e. **Additional LUP Type 2 & 3 Requirement:** LUP Type 2 & 3 dischargers shall ensure that all storm drain inlets and perimeter controls, runoff control BMPs, and pollutant controls at entrances and exits (e.g. tire washoff locations) are maintained and protected from activities that reduce their effectiveness.
- f. **Additional LUP Type 2 & 3 Requirement:** LUP Type 2 & 3 dischargers shall inspect all immediate access roads. At a minimum daily and prior to any rain event, the discharger shall remove any

¹¹ Sheet flow length is the length that shallow, low velocity flow travels across a site.

sediment or other construction activity-related materials that are deposited on the roads (by vacuuming or sweeping).

- g. **Additional LUP Type 3 Requirement:** The Regional Water Board may require LUP Type 3 dischargers to implement additional site-specific sediment control requirements if the implementation of the other requirements in this section are not adequately protecting the receiving waters.

6. Run-on and Run-off Controls

- a. LUP dischargers shall effectively manage all run-on, all runoff within the site and all runoff that discharges off the site. Run-on from off site shall be directed away from all disturbed areas or shall collectively be in compliance with the effluent limitations in this Attachment.
- b. Run-on and runoff controls are not required for Type 1 LUPs unless the evaluation of quantity and quality of run-on and runoff deems them necessary or visual inspections show that the site requires such controls.

7. Inspection, Maintenance and Repair

- a. All inspection, maintenance repair and sampling activities at the discharger's LUP location shall be performed or supervised by a QSP representing the discharger. The QSP may delegate any or all of these activities to an employee trained to do the task(s) appropriately, but shall ensure adequate deployment.
- b. LUP dischargers shall conduct visual inspections and observations daily during working hours (not recorded). At least once each 24-hour period during extended storm events, **LUP Type 2 & 3 dischargers** shall conduct visual inspections to identify and record BMPs that need maintenance to operate effectively, that have failed, or that could fail to operate as intended. Inspectors shall be the QSP or be trained by the QSP.

- c. Upon identifying failures or other shortcomings, as directed by the QSP, LUP dischargers shall begin implementing repairs or design changes to BMPs within 72 hours of identification and complete the changes as soon as possible.
- d. For each pre- and post-rain event inspection required, LUP dischargers shall complete an inspection checklist, using a form provided by the State Water Board or Regional Water Board or in an alternative format that includes the information described below.
- e. The LUP discharger shall ensure that the checklist remains on-site or with the SWPPP. At a minimum, an inspection checklist should include:
 - i. Inspection date and date the inspection report was written.
 - ii. Weather information, including presence or absence of precipitation, estimate of beginning of qualifying storm event, duration of event, time elapsed since last storm, and approximate amount of rainfall in inches.
 - iii. Site information, including stage of construction, activities completed, and approximate area of the site exposed.
 - iv. A description of any BMPs evaluated and any deficiencies noted.
 - v. If the construction site is safely accessible during inclement weather, list the observations of all BMPs: erosion controls, sediment controls, chemical and waste controls, and non-storm water controls. Otherwise, list the results of visual inspections at all relevant outfalls, discharge points, downstream locations and any projected maintenance activities.
 - vi. Report the presence of noticeable odors or of any visible sheen on the surface of any discharges.
 - vii. Any corrective actions required, including any necessary changes to the SWPPP and the associated implementation dates.
 - viii. Photographs taken during the inspection, if any.
 - ix. Inspector's name, title, and signature.

K. STORM WATER POLLUTION PREVENTION PLAN (SWPPP) REQUIREMENTS

1. Objectives

SWPPPs for all LUPs shall be developed and amended or revised by a QSD. The SWPPP shall be designed to address the following objectives:

- a. All pollutants and their sources, including sources of sediment, associated with construction activities associated with LUP activity are controlled;
- b. All non-storm water discharges are identified and either eliminated, controlled, or treated;
- c. BMPs are effective and result in the reduction or elimination of pollutants in storm water discharges and authorized non-storm water discharges from LUPs during construction; and
- d. Stabilization BMPs installed to reduce or eliminate pollutants after construction is completed are effective and maintained.

2. SWPPP Implementation Schedule

- a. LUPs for which PRDs have been submitted to the State Water Board shall develop a site/project location SWPPP prior to the start of land-disturbing activity in accordance with this Section and shall implement the SWPPP concurrently with commencement of soil-disturbing activities.
- b. For an ongoing LUP involving a change in the LRP, the new LRP shall review the existing SWPPP and amend it, if necessary, or develop a new SWPPP within 15 calendar days to conform to the requirements set forth in this General Permit.

3. Availability

The SWPPP shall be available at the construction site during working hours while construction is occurring and shall be made available upon request by a State or Municipal inspector. When the original SWPPP is retained by a crewmember in a construction vehicle and is not currently at the construction site, copies of the BMPs and map/drawing will be left with the field crew and the original SWPPP shall be made available via a request by radio/telephone.

L. REGIONAL WATER BOARD AUTHORITIES

1. Regional Water Boards shall administer the provisions of this General Permit. Administration of this General Permit may include, but is not limited to, requesting the submittal of SWPPPs, reviewing SWPPPs, reviewing monitoring and sampling and analysis reports, conducting compliance inspections, gathering site information by any medium including sampling, photo and video documentation, and taking enforcement actions.
2. Regional Water Boards may terminate coverage under this General Permit for dischargers who fail to comply with its requirements or where they determine that an individual NPDES permit is appropriate.
3. Regional Water Boards may issue separate permits for discharges of storm water associated with construction activity to individual dischargers, categories of dischargers, or dischargers in a geographic area. Upon issuance of such permits by a Regional Water Board, dischargers subject to those permits shall no longer be regulated by this General Permit.
4. Regional Water Boards may direct the discharger to reevaluate the LUP Type(s) for the project (or elements/areas of the project) and impose the appropriate level of requirements.
5. Regional Water Boards may terminate coverage under this General Permit for dischargers who negligently or with willful intent incorrectly determine or report their LUP Type (e.g., they determine themselves to be a LUP Type 1 when they are actually a Type 2).
6. Regional Water Boards may review PRDs and reject or accept applications for permit coverage or may require dischargers to submit a Report of Waste Discharge / NPDES permit application for Regional Water Board consideration of individual requirements.
7. Regional Water Boards may impose additional requirements on dischargers to satisfy TMDL implementation requirements or to satisfy provisions in their Basin Plans.
8. Regional Water Boards may require additional Monitoring and Reporting Program Requirements, including sampling and analysis of discharges to sediment-impaired water bodies.
9. Regional Water Boards may require dischargers to retain records for more than the three years required by this General Permit.

- 10.** Based on an LUP's threat to water quality and complexity, the Regional Water Board may determine on a case-by-case basis that an LUP, or a portion of an LUP, is not eligible for the linear project requirements contained in this Attachment, and require that the discharger comply with all standard requirements in this General Permit.
- 11.** The Regional Water Board may require additional monitoring and reporting program requirements including sampling and analysis of discharges to CWA § 303(d)-listed water bodies. Additional requirements imposed by the Regional Water Board shall be consistent with the overall monitoring effort in the receiving waters.

M. MONITORING AND REPORTING REQUIREMENTS

Table 3. LUP Summary of Monitoring Requirements

LUP Type	Visual Inspections				Sample Collection		
	Daily Site BMP	Pre-storm Event	Daily Storm BMP	Post Storm	Storm Water Discharge	Receiving Water	Non-Visible (when applicable)
		Baseline					
1	X						X
2	X	X	X	X	X		X
3	X	X	X	X	X	X	X

1. Objectives

LUP dischargers shall prepare a monitoring and reporting program (M&RP) prior to the start of construction and immediately implement the program at the start of construction for LUPs. The monitoring program must be implemented at the appropriate level to protect water quality at all times throughout the life of the project. The M&RP must be a part of the SWPPP, included as an appendix or separate SWPPP chapter.

2. M&RP Implementation Schedule

- a. LUP dischargers shall implement the requirements of this Section at the time of commencement of construction activity. LUP dischargers are responsible for implementing these requirements until construction activity is complete and the site is stabilized.
- b. LUP dischargers shall revise the M&RP when:
 - i. Site conditions or construction activities change such that a change in monitoring is required to comply with the requirements and intent of this General Permit.
 - ii. The Regional Water Board requires the discharger to revise its M&RP based on its review of the document. Revisions may include, but not be limited to, conducting additional site inspections, submitting reports, and certifications. Revisions shall be submitted via postal mail or electronic e-mail.

- iii The Regional Water Board may require additional monitoring and reporting program requirements including sampling and analysis of discharges to CWA § 303(d)-listed water bodies. Additional requirements imposed by the Regional Water Board shall be consistent with the overall monitoring effort in the receiving waters.

3. LUP Type 1 Monitoring and Reporting Requirements

a. LUP Type 1 Inspection Requirements

- i LUP Type 1 dischargers shall ensure that all inspections are conducted by trained personnel. The name(s) and contact number(s) of the assigned inspection personnel should be listed in the SWPPP.
- ii LUP Type 1 dischargers shall ensure that all visual inspections are conducted daily during working hours and in conjunction with other daily activities in areas where active construction is occurring.
- iii LUP Type 1 dischargers shall ensure that photographs of the site taken before, during, and after storm events are taken during inspections, and submitted through the State Water Board's SMARTS website once every three rain events.
- iv LUP Type 1 dischargers shall conduct daily visual inspections to verify that:
 - (1) Appropriate BMPs for storm water and non-storm water are being implemented in areas where active construction is occurring (including staging areas);
 - (2) Project excavations are closed, with properly protected spoils, and that road surfaces are cleaned of excavated material and construction materials such as chemicals by either removing or storing the material in protective storage containers at the end of every construction day;
 - (3) Land areas disturbed during construction are returned to pre-construction conditions or an equivalent protection is used at the end of each workday to eliminate or minimize erosion and the possible discharge of sediment or other pollutants during a rain event.
- v Inspections may be discontinued in non-active construction areas where soil-disturbing activities are completed and final soil stabilization is achieved (e.g., paving is completed, substructures

are installed, vegetation meets minimum cover requirements for final stabilization, or other stabilization requirements are met).

- vi Inspection programs are required for LUP Type 1 projects where temporary and permanent stabilization BMPs are installed and are to be monitored after active construction is completed. Inspection activities shall continue until adequate permanent stabilization is established and, in areas where re-vegetation is chosen, until minimum vegetative coverage is established in accordance with Section C.1 of this Attachment.

b. LUP Type 1 Monitoring Requirements for Non-Visible Pollutants

LUP Type 1 dischargers shall implement sampling and analysis requirements to monitor non-visible pollutants associated with (1) construction sites; (2) activities producing pollutants that are not visually detectable in storm water discharges; and (3) activities which could cause or contribute to an exceedance of water quality objectives in the receiving waters.

- i Sampling and analysis for non-visible pollutants is only required where the LUP Type 1 discharger believes pollutants associated with construction activities have the potential to be discharged with storm water runoff due to a spill or in the event there was a breach, malfunction, failure and/or leak of any BMP. Also, failure to implement BMPs may require sample collection.
 - (1) Visual observations made during the monitoring program described above will help the LUP Type 1 discharger determine when to collect samples.
 - (2) The LUP Type 1 discharger is not required to sample if one of the conditions described above (e.g., breach or spill) occurs and the site is cleaned of material and pollutants and/or BMPs are implemented prior to the next storm event.
- ii LUP Type 1 dischargers shall collect samples down-gradient from all discharge locations where the visual observations were made triggering the monitoring, and which can be safely accessed. For sites where sampling and analysis is required, personnel trained in water quality sampling procedures shall collect storm water samples.
- iii If sampling for non-visible pollutant parameters is required, LUP Type 1 dischargers shall ensure that samples be analyzed for parameters indicating the presence of pollutants identified in the pollutant source assessment required in Section J.2.a.i.

- iv LUP Type 1 dischargers shall collect samples during the first two hours of discharge from rain events that occur during business hours and which generate runoff.
 - v LUP Type 1 dischargers shall ensure that a sufficiently large sample of storm water that has not come into contact with the disturbed soil or the materials stored or used on-site (uncontaminated sample¹²) will be collected for comparison with the discharge sample. Samples shall be collected during the first two hours of discharge from rain events that occur during daylight hours and which generate runoff.
 - vi LUP Type 1 dischargers shall compare the uncontaminated sample to the samples of discharge using field analysis or through laboratory analysis. Analyses may include, but are not limited to, indicator parameters such as: pH, specific conductance, dissolved oxygen, conductivity, salinity, and Total Dissolved Solids (TDS).
 - vii For laboratory analyses, all sampling, sample preservation, and other analyses must be conducted according to test procedures pursuant to 40 C.F.R. Part 136. LUP Type 1 dischargers shall ensure that field samples are collected and analyzed according to manufacturer specifications of the sampling devices employed. Portable meters shall be calibrated according to manufacturer's specification.
 - viii LUP Type 1 dischargers shall ensure that all field and/or analytical data are kept in the SWPPP document.
- c. LUP Type 1 Visual Observation Exceptions
- i LUP Type 1 dischargers shall be prepared to collect samples and conduct visual observation (inspections) to meet the minimum visual observation requirements of this Attachment. The Type 1 LUP discharger is not required to physically collect samples or conduct visual observation (inspections) under the following conditions:
 - (1) During dangerous weather conditions such as flooding and electrical storms;
 - (2) Outside of scheduled site business hours.
 - (3) When access to the site is unsafe due to storm events.

¹² Sample collected at a location unaffected by construction activities.

- ii If the LUP Type 1 discharger does not collect the required samples or visual observation (inspections) due to these exceptions, an explanation why the sampling or visual observation (inspections) were not conducted shall be included in both the SWPPP and the Annual Report.
- d. Particle Size Analysis for Risk Justification

LUP Type 1 dischargers utilizing justifying an alternative project risk shall report a soil particle size analysis used to determine the RUSLE K-Factor. ASTM D-422 (Standard Test Method for Particle-Size Analysis of Soils), as revised, shall be used to determine the percentages of sand, very fine sand, silt, and clay on the site.

4. LUP Type 2 & 3 Monitoring and Reporting Requirements

- a. LUP Type 2 & 3 Inspection Requirements
- i LUP Type 2 & 3 dischargers shall ensure that all inspections are conducted by trained personnel. The name(s) and contact number(s) of the assigned inspection personnel should be listed in the SWPPP.
 - ii LUP Type 2 & 3 dischargers shall ensure that all visual inspections are conducted daily during working hours and in conjunction with other daily activities in areas where active construction is occurring.
 - iii LUP Type 2 & 3 dischargers shall ensure that photographs of the site taken before, during, and after storm events are taken during inspections, and submitted through the State Water Board's SMARTS website once every three rain events.
 - iv LUP Type 2 & 3 dischargers shall conduct daily visual inspections to verify that appropriate BMPs for storm water and non-storm water are being implemented and in place in areas where active construction is occurring (including staging areas).
 - v LUP Type 2 & 3 dischargers shall conduct inspections of the construction site prior to anticipated storm events, during extended storm events, and after actual storm events to identify areas contributing to a discharge of storm water associated with construction activity. Pre-storm inspections are to ensure that BMPs are properly installed and maintained; post-storm inspections are to assure that BMPs have functioned adequately. During

extended storm events, inspections shall be required during normal working hours for each 24-hour period.

- vi Inspections may be discontinued in non-active construction areas where soil-disturbing activities are completed and final soil stabilization is achieved (e.g., paving is completed, substructures are installed, vegetation meets minimum cover requirements for final stabilization, or other stabilization requirements are met).
- vii LUP Type 2 & 3 dischargers shall implement a monitoring program for inspecting projects that require temporary and permanent stabilization BMPs after active construction is complete. Inspections shall ensure that the BMPs are adequate and maintained. Inspection activities shall continue until adequate permanent stabilization is established and, in vegetated areas, until minimum vegetative coverage is established in accordance with Section C.1 of this Attachment.
- viii If possible, LUP Type 2 & 3 dischargers shall install a rain gauge on-site at an accessible and secure location with readings made during all storm event inspections. When readings are unavailable, data from the closest rain gauge with publically available data may be used.
- ix LUP Type 2 & 3 dischargers shall include and maintain a log of the inspections conducted in the SWPPP. The log will provide the date and time of the inspection and who conducted the inspection.

b. LUP Type 2 & 3 Storm Water Effluent Monitoring Requirements

Table 4. LUP Type 2 & 3 Effluent Monitoring Requirements

LUP Type	Frequency	Effluent Monitoring
2	Minimum of 3 samples per day characterizing discharges associated with construction activity from the project active areas of construction.	Turbidity, pH, and non-visible pollutant parameters (if applicable)
3	Minimum of 3 samples per day characterizing discharges associated with construction activity from the project active areas of construction.	turbidity, pH, suspended sediment concentrations (SSC) ¹³ (only if turbidity NEL exceeded), plus non-visible pollutant parameters (if applicable)

- i LUP Type 2 & 3 dischargers shall collect storm water grab samples from sampling locations characterizing discharges associated with

¹³ Suspended Sediment Concentration monitoring is required for any Type 3 area that exceeds its turbidity NEL.

activity from the LUP active areas of construction. At a minimum, 3 samples shall be collected per day of discharge.

- ii LUP Type 2 & 3 dischargers shall collect samples of stored or contained storm water that is discharged subsequent to a storm event producing precipitation of ½ inch or more at the time of discharge.
 - iii LUP Type 2 & 3 dischargers shall ensure that storm water grab sample(s) obtained be representative of the flow and characteristics of the discharge.
 - iv LUP Type 2 & 3 dischargers shall analyze their effluent samples for:
 - (1) pH and turbidity
 - (2) Any additional parameter for which monitoring is required by the Regional Water Board.
 - v LUP Type 3 dischargers that have violated the turbidity daily average NEL shall analyze subsequent effluent samples for turbidity and SSC.
- c. LUP Type 2 & 3 Storm Water Effluent Sampling Locations
- i LUP Type 2 & 3 dischargers shall perform sampling and analysis of storm water discharges to characterize discharges associated with construction activity from the entire disturbed project or area.
 - ii LUP Type 2 & 3 dischargers may monitor and report run-on from surrounding areas if there is reason to believe run-on may contribute to exceedance of NALs or NELs (applicable to Type 3).
 - iii LUP Type 2 & 3 dischargers shall select analytical test methods from the list provided in Table 5 below.
 - iv LUP Type 2 & 3 dischargers shall ensure that all storm water sample collection preservation and handling shall be conducted in accordance with the “Storm Water Sample Collection and Handling Instructions” below.
- d. LUP Type 3 Receiving Water Monitoring Requirements
- i In the event that an LUP Type 3 discharger violates an applicable NEL contained in this General Permit and has a direct discharge to receiving waters, the LUP discharger shall subsequently sample Receiving Waters (RWs) for turbidity, pH (if applicable) and SSC.

- ii LUP Type 3 dischargers that meet the project criteria in Appendix 3 of this General Permit and have more than 30 acres of soil disturbance in the project area or project section area designated as Type 3, shall comply with the Bioassessment requirements prior to commencement of construction activity.
 - iii LUP Type 3 dischargers shall obtain RW samples in accordance with the requirements of the Receiving Water Sampling Locations section (Section M.4.d of this Attachment).
- e. LUP Type 3 Receiving Water Sampling Locations
- i **Upstream/up-gradient RW samples:** LUP Type 3 dischargers shall obtain any required upstream/up-gradient receiving water samples from a representative and accessible location as close as possible to and upstream from the effluent discharge point.
 - ii **Downstream/down-gradient RW samples:** LUP Type 3 dischargers shall obtain any required downstream/down-gradient receiving water samples from a representative and accessible location as close as possible to and downstream from the effluent discharge point.
 - iii If two or more discharge locations discharge to the same receiving water, LUP Type 3 dischargers may sample the receiving water at a single upstream and downstream location.
- f. LUP Type 2 & 3 Monitoring Requirements for Non-Visible Pollutants

LUP Type 2 & 3 dischargers shall implement sampling and analysis requirements to monitor non-visible pollutants associated with (1) construction sites; (2) activities producing pollutants that are not visually detectable in storm water discharges; and (3) activities which could cause or contribute to an exceedance of water quality objectives in the receiving waters.

- i Sampling and analysis for non-visible pollutants is only required where LUP Type 2 & 3 dischargers believe pollutants associated with construction activities have the potential to be discharged with storm water runoff due to a spill or in the event there was a breach, malfunction, failure and/or leak of any BMP. Also, failure to implement BMPs may require sample collection.

(1) Visual observations made during the monitoring program described above will help LUP Type 2 & 3 dischargers determine when to collect samples.

- (2) LUP Type 2 & 3 dischargers are not required to sample if one of the conditions described above (e.g., breach or spill) occurs and the site is cleaned of material and pollutants and/or BMPs are implemented prior to the next storm event.
- ii LUP Type 2 & 3 dischargers shall collect samples down-gradient from the discharge locations where the visual observations were made triggering the monitoring and which can be safely accessed. For sites where sampling and analysis is required, personnel trained in water quality sampling procedures shall collect storm water samples.
 - iii If sampling for non-visible pollutant parameters is required, LUP Type 2 & 3 dischargers shall ensure that samples be analyzed for parameters indicating the presence of pollutants identified in the pollutant source assessment required in Section J.2.a.i.
 - iv LUP Type 2 & 3 dischargers shall collect samples during the first two hours of discharge from rain events that occur during business hours and which generate runoff.
 - v LUP Type 2 & 3 dischargers shall ensure that a sufficiently large sample of storm water that has not come into contact with the disturbed soil or the materials stored or used on-site (uncontaminated sample¹⁴) will be collected for comparison with the discharge sample. Samples shall be collected during the first two hours of discharge from rain events that occur during daylight hours and which generate runoff.
 - vi LUP Type 2 & 3 dischargers shall compare the uncontaminated sample to the samples of discharge using field analysis or through laboratory analysis. Analyses may include, but are not limited to, indicator parameters such as: pH, specific conductance, dissolved oxygen, conductivity, salinity, and Total Dissolved Solids (TDS).
 - vii For laboratory analyses, all sampling, sample preservation, and other analyses must be conducted according to test procedures pursuant to 40 C.F.R. Part 136. LUP Type 2 & 3 dischargers shall ensure that field samples are collected and analyzed according to manufacturer specifications of the sampling devices employed. Portable meters shall be calibrated according to manufacturer's specification.
 - viii LUP Type 2 & 3 dischargers shall ensure that all field and/or analytical data are kept in the SWPPP document.

¹⁴ Sample collected at a location unaffected by construction activities

g. LUP Type 2 & 3 Visual Observation and Sample Collection Exceptions

- i LUP Type 2 & 3 dischargers shall be prepared to collect samples and conduct visual observation (inspections) to meet the minimum visual observation requirements of this Attachment. Type 2 & 3 LUP dischargers are not required to physically collect samples or conduct visual observation (inspections) under the following conditions:
 - (1) During dangerous weather conditions such as flooding and electrical storms;
 - (2) Outside of scheduled site business hours.
 - (3) When access to the site is unsafe due to storm events.
- ii If the LUP Type 2 or 3 discharger does not collect the required samples or visual observation (inspections) due to these exceptions, an explanation why the sampling or visual observation (inspections) were not conducted shall be included in both the SWPPP and the Annual Report.

h. LUP Type 2 & 3 Storm Water Sample Collection and Handling Instructions

LUP Type 2 & 3 dischargers shall refer to Table 5 below for test Methods, detection Limits, and reporting Units. During storm water sample collection and handling, the LUP Type 2 & 3 discharger shall:

- i Identify the parameters required for testing and the number of storm water discharge points that will be sampled. Request the laboratory to provide the appropriate number of sample containers, types of containers, sample container labels, blank chain of custody forms, and sample preservation instructions.
- ii Determine how to ship the samples to the laboratory. The testing laboratory should receive samples within 48 hours of the physical sampling (unless otherwise required by the laboratory). The options are to either deliver the samples to the laboratory, arrange to have the laboratory pick them up, or ship them overnight to the laboratory.
- iii Use only the sample containers provided by the laboratory to collect and store samples. Use of any other type of containers could contaminate your samples.

- iv Prevent sample contamination, by not touching, or putting anything into the sample containers before collecting storm water samples.
- v Not overfilling sample containers. Overfilling can change the analytical results.
- vi Tightly screw the cap of each sample container without stripping the threads of the cap.
- vii Complete and attach a label to each sample container. The label shall identify the date and time of sample collection, the person taking the sample, and the sample collection location or discharge point. The label should also identify any sample containers that have been preserved.
- viii Carefully pack sample containers into an ice chest or refrigerator to prevent breakage and maintain temperature during shipment. Remember to place frozen ice packs into the shipping container. Samples should be kept as close to 4° C (39° F) as possible until arriving at the laboratory. Do not freeze samples.
- ix Complete a Chain of Custody form for each set of samples. The Chain of Custody form shall include the discharger's name, address, and phone number, identification of each sample container and sample collection point, person collecting the samples, the date and time each sample container was filled, and the analysis that is required for each sample container.
- x Upon shipping/delivering the sample containers, obtain both the signatures of the persons relinquishing and receiving the sample containers.
- xi Designate and train personnel to collect, maintain, and ship samples in accordance with the above sample protocols and good laboratory practices.
- xii Refer to the Surface Water Ambient Monitoring Program's (SWAMP) Quality Assurance Management Plan (QAMP) for more information on sampling collection and analysis. See http://www.waterboards.ca.gov/water_issues/programs/swamp/¹⁵
QAMP Link:
http://www.waterboards.ca.gov/water_issues/programs/swamp/qamp.shtml

¹⁵ Additional information regarding QAMP can be found at <http://mpsl.mlml.calstate.edu/swgacompare.htm>.

Table 5. Test Methods, Detection Limits, Reporting Units and Applicable NALs/NELs

Parameter	Test Method	Discharge Type	Min. Detection Limit	Reporting Units	Numeric Action Levels	Numeric Effluent Limitation (LUP Type 3)
pH	Field test with calibrated portable instrument	Type 2 & 3	0.2	pH units	Lower = 6.5 upper = 8.5	Lower = 6.0 upper = 9.0
Turbidity	EPA 0180.1 and/or field test with calibrated portable instrument	Type 2 & 3	1	NTU	250 NTU	500 NTU
SSC	ASTM Method D 3977-97 ¹⁶	Type 3 if NEL is exceeded	5 Mg/L		N/A	N/A
Bioassessment	(STE) Level I of (SAFIT), ¹⁷ fixed-count of 600 org/sample	Type 3 LUPs > 30 acres	N/A N/A		N/A	N/A

i. LUP Type 2 & 3 Monitoring Methods

i The LUP Type 2 or 3 discharger's project M&RP shall include a description of the following items:

- (1) Visual observation locations, visual observation procedures, and visual observation follow-up and tracking procedures.
- (2) Sampling locations, and sample collection and handling procedures. This shall include detailed procedures for sample collection, storage, preservation, and shipping to the testing lab to assure that consistent quality control and quality assurance is maintained. Dischargers shall attach to the monitoring program a copy of the Chain of Custody form used when handling and shipping samples.

¹⁶ ASTM, 1999, Standard Test Method for Determining Sediment Concentration in Water Samples: American Society of Testing and Materials, D 3977-97, Vol. 11.02, pp. 389-394

¹⁷ The current SAFIT STEs (28 November 2006) list requirements for both the Level I and Level II taxonomic effort, and are located at: http://www.swrcb.ca.gov/swamp/docs/safit/ste_list.pdf. When new editions are published by SAFIT, they will supersede all previous editions. All editions will be posted at the State Water Board's SWAMP website.

(3) Identification of the analytical methods and related method detection limits (if applicable) for each parameter required in Section M.4.f above.

- ii LUP Type 2 & 3 dischargers shall ensure that all sampling and sample preservation be in accordance with the current edition of "Standard Methods for the Examination of Water and Wastewater" (American Public Health Association). All monitoring instruments and equipment (including a discharger's own field instruments for measuring pH and turbidity) shall be calibrated and maintained in accordance with manufacturers' specifications to ensure accurate measurements. All laboratory analyses shall be conducted according to test procedures under 40 CFR Part 136, unless other test procedures have been specified in this General Permit or by the Regional Water Board. With the exception of field analysis conducted by the discharger for turbidity and pH, all analyses shall be sent to and conducted at a laboratory certified for such analyses by the State Department of Health Services (SSC exception). The LUP discharger shall conduct its own field analysis of pH and may conduct its own field analysis of turbidity if the discharger has sufficient capability (qualified and trained employees, properly calibrated and maintained field instruments, etc.) to adequately perform the field analysis.

j. LUP Type 2 & 3 Analytical Methods

LUP Type 2 & 3 dischargers shall refer to Table 5 above for test Methods, detection Limits, and reporting Units.

- i **pH:** LUP Type 2 & 3 dischargers shall perform pH analysis on-site with a calibrated pH meter or pH test kit. The LUP discharger shall record pH monitoring results on paper and retain these records in accordance with Section M.4.o, below.
- ii **Turbidity:** LUP Type 2 & 3 dischargers shall perform turbidity analysis using a calibrated turbidity meter (turbidimeter), either on-site or at an accredited lab. Acceptable test methods include Standard Method 2130 or USEPA Method 180.1. The results shall be recorded in the site log book in Nephelometric Turbidity Units (NTU).
- iii **Suspended sediment concentration (SSC):** LUP Type 3 dischargers exceeding their NEL, shall perform SSC analysis using ASTM Method D3977-97.

- iv **Bioassessment:** LUP Type 3 dischargers shall perform bioassessment sampling and analysis according to Appendix 3 of this General Permit.

k. Watershed Monitoring Option

If an LUP Type 2 or 3 discharger is part of a qualified regional watershed-based monitoring program the LUP Type 2 or 3 discharger may be eligible for relief from the monitoring requirements in this Attachment. The Regional Water Board may approve proposals to substitute an acceptable watershed-based monitoring program if it determines that the watershed-based monitoring program will provide information to determine each discharger's compliance with the requirements of this General Permit.

l. Particle Size Analysis for Risk Justification

LUP Type 2 & 3 dischargers justifying an alternative project risk shall report a soil particle size analysis used to determine the RUSLE K-Factor. ASTM D-422 (Standard Test Method for Particle-Size Analysis of Soils), as revised, shall be used to determine the percentages of sand, very fine sand, silt, and clay on the site.

m. NAL Exceedance Report

- i In the event that any effluent sample exceeds an applicable NAL, the Regional Water Boards may require LUP Type 2 & 3 dischargers to submit NAL Exceedance Reports.
- ii LUP Type 2 & 3 dischargers shall certify each NAL Exceedance Report in accordance with the Special Provisions for Construction Activity.
- iii LUP Type 2 & 3 dischargers shall retain an electronic or paper copy of each NAL Exceedance Report for a minimum of three years after the date the exceedance report is filed.
- iv LUP Type 2 & 3 dischargers shall include in the NAL Exceedance Report:
 - (1) the analytical method(s), method reporting unit(s), and method detection limit(s) of each analytical parameter (analytical results that are less than the method detection limit shall be reported as "less than the method detection limit"); and
 - (2) the date, place, time of sampling, visual observation (inspections), and/or measurements, including precipitation.

- (3) Description of the current BMPs associated with the effluent sample that exceeded the NAL and the proposed corrective actions taken.

n. NEL Violation Report

- i All LUP Type 3 dischargers shall electronically submit all storm event sampling results to the State Water Board no later than 5 days after the conclusion of the storm event.
- ii In the event that a LUP Type 3 discharger has violated an applicable NEL, the discharger shall submit an NEL Violation Report to the State Water Board no later than 24 hours after the NEL exceedance has been identified.
- iii The LUP Type 3 discharger shall certify each NEL Violation Report in accordance with the Special Provisions for Construction Activity.
- iv The LUP Type 3 discharger shall retain an electronic or paper copy of each NEL Violation Report for a minimum of three years after the date the violation report is filed.
- v The LUP Type 3 discharger shall include in the NEL Violation Report:
 - (1) the analytical method(s), method reporting unit(s), and method detection limit(s) of each analytical parameter (analytical results that are less than the method detection limit shall be reported as “less than the method detection limit”); and
 - (2) the date, place, time of sampling, visual observation (inspections), and/or measurements, including precipitation.
 - (3) Description of the current on-site BMPs, and the proposed corrective actions taken to manage the NEL exceedance.
- vi Compliance Storm Exemption:
In the event that an applicable NEL has been exceeded during a storm event equal to or larger than the Compliance Storm Event (see Section F.2.c of this Attachment), the LUP Type 3 discharger shall report the on-site rain gauge and nearby governmental rain gauge readings for verification.

o. Monitoring Records

LUP Type 2 & 3 dischargers shall ensure that records of all storm water monitoring information and copies of all reports (including Annual Reports) required by this General Permit be retained for a period of at least three years. LUP Type 2 & 3 dischargers may retain records off-

site and make them available upon request. These records shall include:

- i The date, place, time of facility inspections, sampling, visual observation (inspections), and/or measurements, including precipitation (rain gauge);
- ii The individual(s) who performed the facility inspections, sampling, visual observation (inspections), and or measurements;
- iii The date and approximate time of analyses;
- iv The individual(s) who performed the analyses;
- v A summary of all analytical results from the last three years, the method detection limits and reporting units, the analytical techniques or methods used, and all chain of custody forms;
- vi Quality assurance/quality control records and results;
- vii Non-storm water discharge inspections and visual observation (inspections) and storm water discharge visual observation records (see Section M.4.a above);
- viii Visual observation and sample collection exception records (see Section M.4.g above); and
- ix The records of any corrective actions and follow-up activities that resulted from analytical results, visual observation (inspections), or inspections.

ATTACHMENT A.1 LUP Project Area or Project Section Area Type Determination

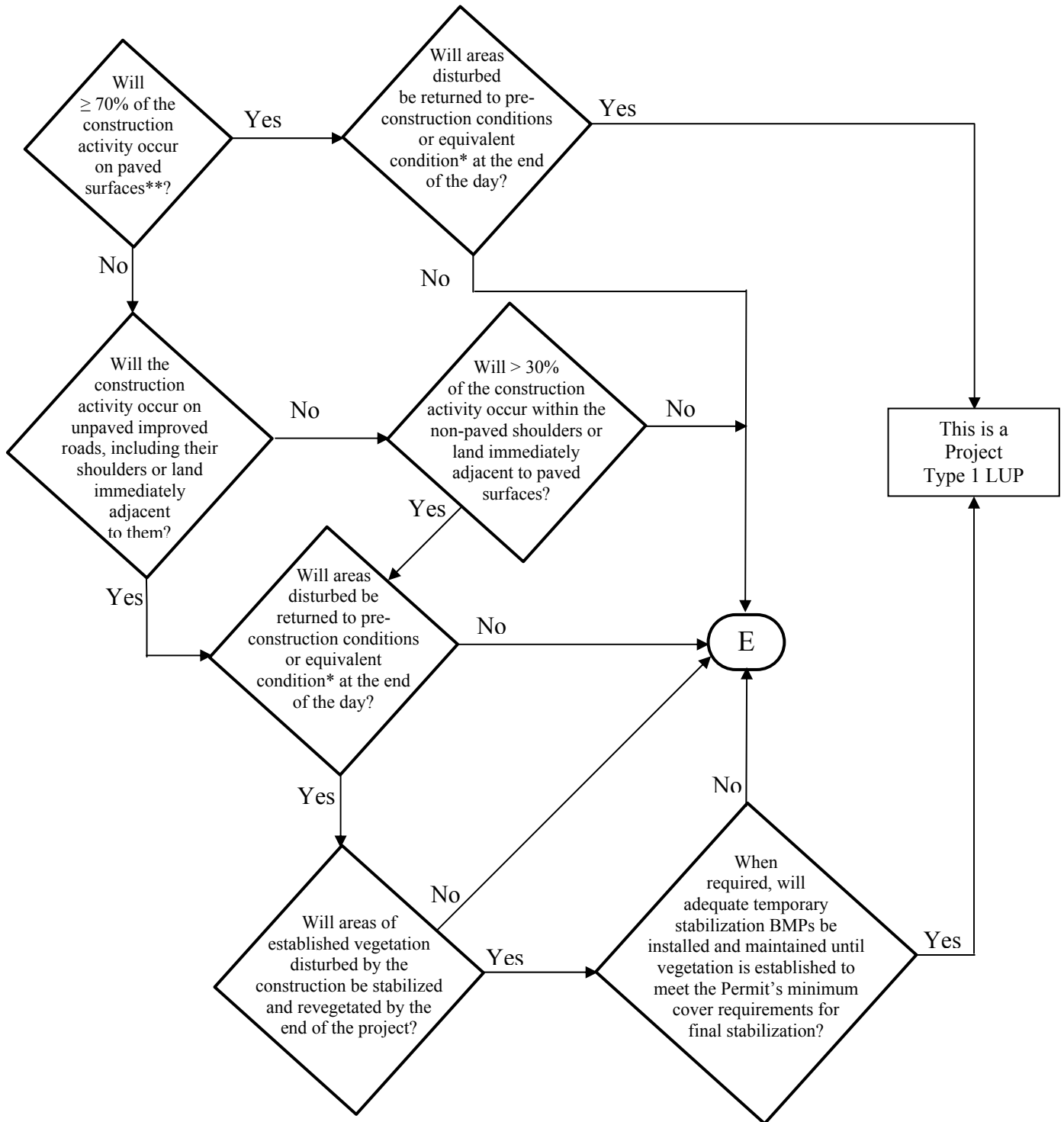

*See Definition of Terms

** Or: "Will < 30% of the soil disturbance occur on unpaved surfaces?"

ATTACHMENT A.1 LUP Project Area or Project Section Area Type Determination

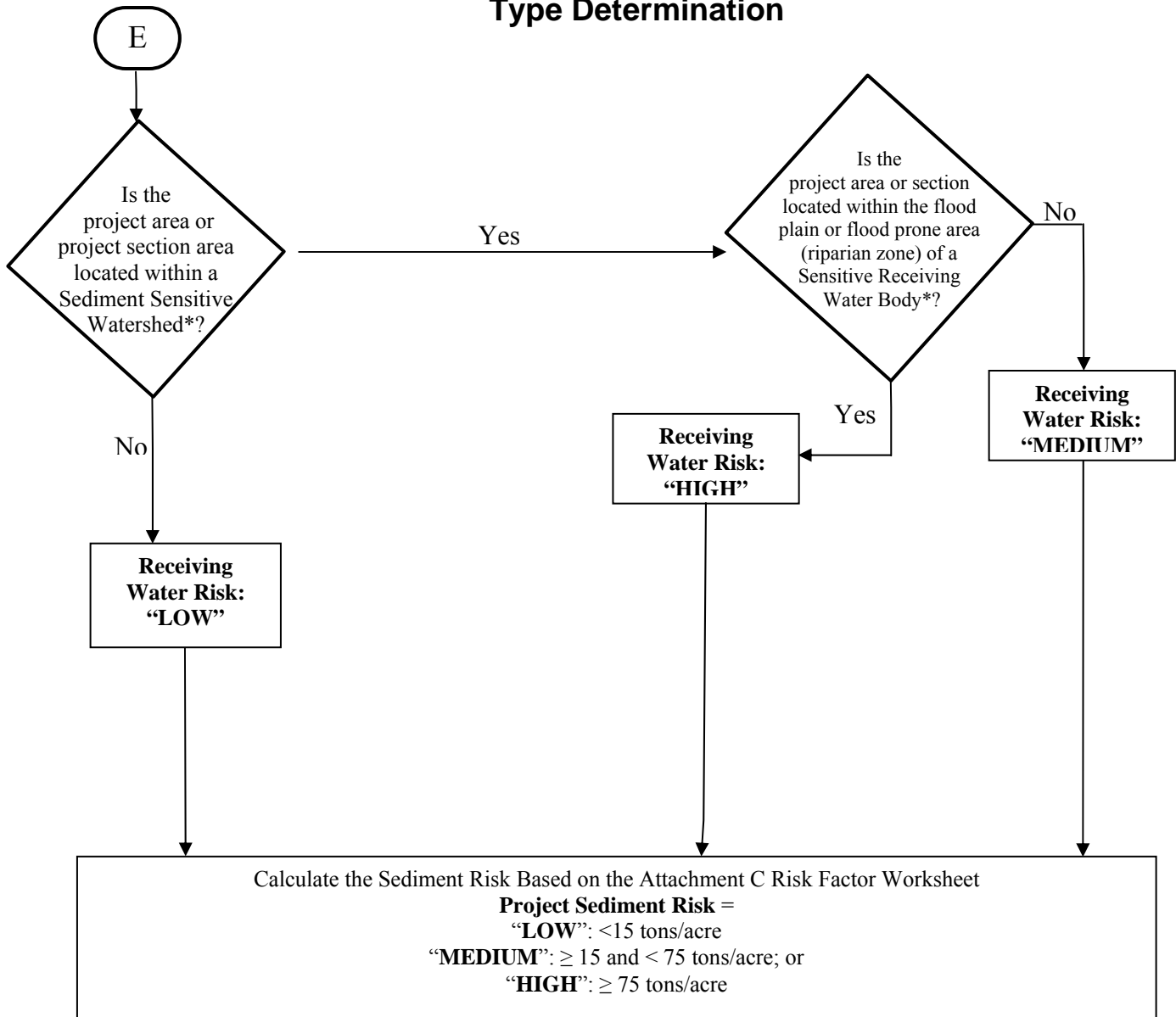

* See Definition of Terms

PROJECT SEDIMENT RISK

RECEIVING WATER RISK

	LOW	MEDIUM	HIGH
LOW	Type 1	Type 1	Type 2
MEDIUM	Type 1	Type 2	Type 3
HIGH	Type 2	Type 3	Type 3

ATTACHMENT A.1

Definition of Terms

1. **Equivalent Condition** – Means disturbed soils such as those from trench excavation are required to be hauled away, backfilled into the trench, and/or covered (e.g., metal plates, pavement, plastic covers over spoil piles) at the end of the construction day.
2. **Linear Construction Activity** – Linear construction activity consists of underground/ overhead facilities that typically include, but are not limited to, any conveyance, pipe or pipeline for the transportation of any gaseous, liquid (including water, wastewater for domestic municipal services), liquescent, or slurry substance; any cable line or wire for the transmission of electrical energy; any cable line or wire for communications (e.g., telephone, telegraph, radio or television messages); and associated ancillary facilities. Construction activities associated with LUPs include, but are not limited to those activities necessary for the installation of underground and overhead linear facilities (e.g., conduits, substructures, pipelines, towers, poles, cables, wires, connectors, switching, regulating and transforming equipment and associated ancillary facilities) and include, but are not limited to, underground utility mark-out, potholing, concrete and asphalt cutting and removal, trenching, excavation, boring and drilling, access road and pole/ tower pad and cable/ wire pull station, substation construction, substructure installation, construction of tower footings and/or foundations, pole and tower installations, pipeline installations, welding, concrete and/or pavement repair or replacement, and stockpile/ borrow locations.
3. **Sediment Sensitive Receiving Water Body** – Defined as a water body segment that is listed on EPA's approved CWA 303(d) list for sedimentation/siltation, turbidity, or is designated with beneficial uses of SPAWN, MIGRATORY, and COLD.
4. **Sediment Sensitive Watershed** – Defined as a watershed draining into a receiving water body listed on EPA's approved CWA 303(d) list for sedimentation/siltation, turbidity, or a water body designated with beneficial uses of SPAWN, MIGRATORY, and COLD.

**ATTACHMENT A.2
PERMIT REGISTRATION DOCUMENTS (PRDs)
GENERAL INSTRUCTIONS FOR LINEAR UNDERGROUND/OVERHEAD PROJECTS TO
COMPLY WITH THE CONSTRUCTION GENERAL PERMIT**

GENERAL INSTRUCTIONS

Who Must Submit

This permit is effective on July 1, 2010.

The Legally Responsible Person (LRP) for construction activities associated with linear underground/overhead project (LUP) must electronically apply for coverage under this General Permit on or after July 1, 2010. If it is determined that the LUP construction activities require an NPDES permit, the Legally Responsible Person¹ (LRP) shall submit PRDs for this General Permit in accordance with the following:

LUPs associated with Private or Municipal Development Projects

1. For LUPs associated with pre-development and pre-redevelopment construction activities:

The LRP must obtain coverage² under this General Permit for its pre-development and pre-redevelopment construction activities where the total disturbed land area of these construction activities is greater than 1 acre.

2. For LUPs associated with new development and redevelopment construction projects:

The LRP must obtain coverage under this General Permit for LUP construction activities associated with new development and redevelopment projects where the total disturbed land area of the LUP is greater than 1 acre. Coverage under this permit is not required where the same LUP construction activities are covered by another NPDES permit.

LUPs not associated with private or municipal new development or redevelopment projects:

The LRP must obtain coverage under this General Permit on or after July 1, 2010 for its LUP construction activities where the total disturbed land area is greater than 1 acre.

PRD Submittal Requirements

Prior to the start of construction activities a LRP must submit PRDs and fees to the State Water Board for each LUP.

New and Ongoing LUPs

Dischargers of new LUPs that commence construction activities after the adoption date of this General Permit shall file PRDs prior to the commencement of construction and implement the SWPPP upon the start of construction.

¹ person possessing the title of the land on which the construction activities will occur for the regulated site

² obtain coverage means filing PRDs for the project.

PERMIT REGISTRATION DOCUMENTS (PRDs) GENERAL INSTRUCTIONS (CONTINUED)

Dischargers of ongoing LUPs that are currently covered under State Water Board Order No. 2003-0007 (Small LUP General Permit) shall electronically file Permit Registration Documents no later than July 1, 2010. After July 1, 2010, all NOIs subject to State Water Board Order No. 2003-0007-DWQ will be terminated. All existing dischargers shall be exempt from the risk determination requirements in Attachment A. All existing dischargers are therefore subject to LUP Type 1 requirements regardless of their project's sediment and receiving water risks. However, a Regional Board retains the authority to require an existing discharger to comply with the risk determination requirements in Attachment A.

Where to Apply

The Permit Registration Documents (PRDs) can be found at www.waterboards.ca.gov/water_issues/programs/stormwater/

Fees

The annual fee for storm water permits are established through the State of California Code of Regulations.

When Permit Coverage Commences

To obtain coverage under the General Permit, the LRP must include the complete PRDs and the annual fee. All PRDs deemed incomplete will be rejected with an explanation as to what is required to complete submittal. Upon receipt of complete PRDs and associated fee, each discharger will be sent a waste discharger's identification (WDID) number.

Projects and Activities Not Defined As Construction Activity

1. LUP construction activity does not include routine maintenance projects to maintain original line and grade, hydraulic capacity, or original purpose of the facility. Routine maintenance projects are projects associated with operations and maintenance activities that are conducted on existing lines and facilities and within existing right-of-way, easements, franchise agreements or other legally binding agreements of the discharger. Routine maintenance projects include, but are not limited to projects that are conducted to:
 - Maintain the original purpose of the facility, or hydraulic capacity.
 - Update existing lines³ and facilities to comply with applicable codes, standards and regulations regardless if such projects result in increased capacity.
 - Repairing leaks.

Routine maintenance does not include construction of new⁴ lines or facilities resulting from compliance with applicable codes, standards and regulations.

³ Update existing lines includes replacing existing lines with new materials or pipes.

⁴ New lines are those that are not associated with existing facilities and are not part of a project to update or replace existing lines.

**PERMIT REGISTRATION DOCUMENTS (PRDs)
GENERAL INSTRUCTIONS (CONTINUED)**

Routine maintenance projects do not include those areas of maintenance projects that are outside of an existing right-of-way, franchise, easements, or agreements. When a project must acquire new areas, those areas may be subject to this General Permit based on the area of disturbed land outside the original right-of-way, easement or agreement.

2. LUP construction activity does not include field activities associated with the planning and design of a project (e.g., activities associated with route selection).
3. Tie-ins conducted immediately adjacent to “energized” or “pressurized” facilities by the discharger are not considered small construction activities where all other LUP construction activities associated with the tie-in are covered by a NOI and SWPPP of a third party or municipal agency.

Calculating Land Disturbance Areas of LUPs

The total land area disturbed for LUPs is the sum of the:

- Surface areas of trenches, laterals and ancillary facilities, plus
- Area of the base of stockpiles on unpaved surfaces, plus
- Surface area of the borrow area, plus
- Areas of paved surfaces constructed for the project, plus
- Areas of new roads constructed or areas of major reconstruction to existing roads (e.g. improvements to two-track surfaces or road widening) for the sole purpose of accessing construction activities or as part of the final project, plus
- Equipment and material storage, staging, and preparation areas (laydown areas) not on paved surfaces, plus
- Soil areas outside the surface area of trenches, laterals and ancillary facilities that will be graded, and/or disturbed by the use of construction equipment, vehicles and machinery during construction activities.

Stockpiling Areas

Stockpiling areas, borrow areas and the removal of soils from a construction site may or may not be included when calculating the area of disturbed soil for a site depending on the following conditions:

- For stockpiling of soils onsite or immediately adjacent to a LUP site and the stockpile is not on a paved surface, the area of the base of the stockpile is to be included in the disturbed area calculation.
- The surface area of borrow areas that are onsite or immediately adjacent to a project site are to be included in the disturbed area calculation.
- For soil that is hauled offsite to a location owned or operated by the discharger that is not a paved surface, the area of the base of the stockpile is to be included in the disturbed area calculation except when the offsite location is already subject to a separate storm water permit.

**PERMIT REGISTRATION DOCUMENTS (PRDs)
GENERAL INSTRUCTIONS (CONTINUED)**

- For soil that is brought to the project from an off-site location owned or operated by the discharger the surface area of the borrow pit is to be included in the disturbed area calculation except when the offsite location is already subject to a separate storm water permit.
- Trench spoils on a paved surface that are either returned to the trench or excavation or hauled away from the project daily for disposal or reuse will not be included in the disturbed area calculation.

If you have any questions concerning submittal of PRDs, please call the State Water Board at (866) 563-3107.

**ATTACHMENT B
PERMIT REGISTRATION DOCUMENTS (PRDs) TO COMPLY WITH THE TERMS
OF THE GENERAL PERMIT TO DISCHARGE STORM WATER
ASSOCIATED WITH CONSTRUCTION ACTIVITY**

GENERAL INSTRUCTIONS

- A.** All Linear Construction Projects shall comply with the PRD requirements in Attachment A.2 of this Order.

B. Who Must Submit

Discharges of storm water associated with construction that results in the disturbance of one acre or more of land must apply for coverage under the General Construction Storm Water Permit (General Permit). Any construction activity that is a part of a larger common plan of development or sale must also be permitted, regardless of size. (For example, if 0.5 acre of a 20-acre subdivision is disturbed by the construction activities of discharger A and the remaining 19.5 acres is to be developed by discharger B, discharger A must obtain a General Storm Water Permit for the 0.5 acre project).

Other discharges from construction activities that are covered under this General Permit can be found in the General Permit Section II.B.

It is the LRP's responsibility to obtain coverage under this General Permit by electronically submitting complete PRDs (Permit Registration Documents).

In all cases, the proper procedures for submitting the PRDs must be completed before construction can commence.

C. Construction Activity Not Covered By This General Permit

Discharges from construction that are not covered under this General Permit can be found in the General Permit Sections II.A & B..

D. Annual Fees and Fee Calculation

Annual fees are calculated based upon the total area of land to be disturbed not the total size of the acreage owned. However, the calculation includes all acres to be disturbed during the duration of the project. For example, if 10 acres are scheduled to be disturbed the first year and 10 in each subsequent year for 5 years, the annual fees would be based upon 50 acres of disturbance. The State Water Board will evaluate adding acreage to an existing Permit Waste Discharge Identification (WDID) number on a case-by-case basis. In general, any acreage to be considered must be contiguous to the permitted land area and the existing

SWPPP must be appropriate for the construction activity and topography of the acreage under consideration. As acreage is built out and stabilized or sold, the Change of Information (COI) form enables the applicant to remove those acres from inclusion in the annual fee calculation. Checks should be made payable to: State Water Board.

The Annual fees are established through regulations adopted by the State Water Board. The total annual fee is the current base fee plus applicable surcharges for all construction sites submitting an NOI, based on the total acreage to be disturbed during the life of the project. Annual fees are subject to change by regulation.

Dischargers that apply for and satisfy the Small Construction Erosivity Waiver requirements shall pay a fee of \$200.00 plus an applicable surcharge, see the General Permit Section II.B.7.

E. When to Apply

LRP's proposing to conduct construction activities subject to this General Permit must submit their PRDs prior to the commencement of construction activity.

F. Requirements for Completing Permit Registration Documents (PRDs)

All dischargers required to comply with this General Permit shall electronically submit the required PRDs for their type of construction as defined below.

G. Standard PRD Requirements (All Dischargers)

1. Notice of Intent
2. Risk Assessment (Standard or Site-Specific)
3. Site Map
4. SWPPP
5. Annual Fee
6. Certification

H. Additional PRD Requirements Related to Construction Type

1. Discharger in unincorporated areas of the State (not covered under an adopted Phase I or II SUSMP requirements) and that are not a linear project shall also submit a completed:
 - a. Post-Construction Water Balance Calculator (Appendix 2).
2. Dischargers who are proposing to implement ATS shall submit:
 - a. Complete ATS Plan in accordance with Attachment F at least 14 days prior to the planned operation of the ATS and a paper copy shall be available onsite during ATS operation.

- b. Certification proof that design done by a professional in accordance with Attachment F.
- 3. Dischargers who are proposing an alternate Risk Justification:
 - a. Particle Size Analysis.

I. Exceptions to Standard PRD Requirements

Construction sites with an R value less than 5 as determined in the Risk Assessment are not required to submit a SWPPP.

J. Description of PRDs

1. Notice of Intent (NOI)
2. Site Map(s) Includes:
 - a. The project's surrounding area (vicinity)
 - b. Site layout
 - c. Construction site boundaries
 - d. Drainage areas
 - e. Discharge locations
 - f. Sampling locations
 - g. Areas of soil disturbance (temporary or permanent)
 - h. Active areas of soil disturbance (cut or fill)
 - i. Locations of all runoff BMPs
 - j. Locations of all erosion control BMPs
 - k. Locations of all sediment control BMPs
 - l. ATS location (if applicable)
 - m. Locations of sensitive habitats, watercourses, or other features which are not to be disturbed
 - n. Locations of all post-construction BMPs
 - o. Locations of storage areas for waste, vehicles, service, loading/unloading of materials, access (entrance/exits) points to construction site, fueling, and water storage, water transfer for dust control and compaction practices
3. **SWPPPs**
A site-specific SWPPP shall be developed by each discharger and shall be submitted with the PRDs.
4. **Risk Assessment**
All dischargers shall use the Risk Assessment procedure as describe in the General Permit Appendix 1.
 - a. The Standard Risk Assessment includes utilization of the following:
 - i. Receiving water Risk Assessment interactive map

- ii. EPA Rainfall Erosivity Factor Calculator Website
 - iii. Sediment Risk interactive map
 - iv. Sediment sensitive water bodies list
- b. The Site-Specific Risk Assessment includes the completion of the hand calculated R value Risk Calculator
5. **Post-Construction Water Balance Calculator**
All dischargers subject to this requirement shall complete the Water Balance Calculator (in Appendix 2) in accordance with the instructions.
6. **ATS Design Document and Certification**
All dischargers using ATS must submit electronically their system design (as well as any supporting documentation) and proof that the system was designed by a qualified ATS design professional (See Attachment F).

To obtain coverage under the General Permit PRDs must be included and completed. If any of the required items are missing, the PRD submittal is considered incomplete and will be rejected. Upon receipt of a complete PRD submittal, the State Water Board will process the application package in the order received and assign a (WDID) number.

Questions?

If you have any questions on completing the PRDs please email stormwater@waterboards.ca.gov or call (866) 563-3107.

ATTACHMENT C RISK LEVEL 1 REQUIREMENTS

A. Effluent Standards

[These requirements are the same as those in the General Permit order.]

1. Narrative – Risk Level 1 dischargers shall comply with the narrative effluent standards listed below:
 - a. Storm water discharges and authorized non-storm water discharges regulated by this General Permit shall not contain a hazardous substance equal to or in excess of reportable quantities established in 40 C.F.R. §§ 117.3 and 302.4, unless a separate NPDES Permit has been issued to regulate those discharges.
 - b. Dischargers shall minimize or prevent pollutants in storm water discharges and authorized non-storm water discharges through the use of controls, structures, and management practices that achieve BAT for toxic and non-conventional pollutants and BCT for conventional pollutants.
2. Numeric – Risk Level 1 dischargers are not subject to a numeric effluent standard.

B. Good Site Management "Housekeeping"

1. Risk Level 1 dischargers shall implement good site management (i.e., "housekeeping") measures for construction materials that could potentially be a threat to water quality if discharged. At a minimum, Risk Level 1 dischargers shall implement the following good housekeeping measures:
 - a. Conduct an inventory of the products used and/or expected to be used and the end products that are produced and/or expected to be produced. This does not include materials and equipment that are designed to be outdoors and exposed to environmental conditions (i.e. poles, equipment pads, cabinets, conductors, insulators, bricks, etc.).
 - b. Cover and berm loose stockpiled construction materials that are not actively being used (i.e. soil, spoils, aggregate, fly-ash, stucco, hydrated lime, etc.).

- c. Store chemicals in watertight containers (with appropriate secondary containment to prevent any spillage or leakage) or in a storage shed (completely enclosed).
 - d. Minimize exposure of construction materials to precipitation. This does not include materials and equipment that are designed to be outdoors and exposed to environmental conditions (i.e. poles, equipment pads, cabinets, conductors, insulators, bricks, etc.).
 - e. Implement BMPs to prevent the off-site tracking of loose construction and landscape materials.
2. Risk Level 1 dischargers shall implement good housekeeping measures for waste management, which, at a minimum, shall consist of the following:
- a. Prevent disposal of any rinse or wash waters or materials on impervious or pervious site surfaces or into the storm drain system.
 - b. Ensure the containment of sanitation facilities (e.g., portable toilets) to prevent discharges of pollutants to the storm water drainage system or receiving water.
 - c. Clean or replace sanitation facilities and inspecting them regularly for leaks and spills.
 - d. Cover waste disposal containers at the end of every business day and during a rain event.
 - e. Prevent discharges from waste disposal containers to the storm water drainage system or receiving water.
 - f. Contain and securely protect stockpiled waste material from wind and rain at all times unless actively being used.
 - g. Implement procedures that effectively address hazardous and non-hazardous spills.
 - h. Develop a spill response and implementation element of the SWPPP prior to commencement of construction activities. The SWPPP shall require that:
 - i. Equipment and materials for cleanup of spills shall be available on site and that spills and leaks shall be cleaned up immediately and disposed of properly; and

- ii. Appropriate spill response personnel are assigned and trained.
 - i. Ensure the containment of concrete washout areas and other washout areas that may contain additional pollutants so there is no discharge into the underlying soil and onto the surrounding areas.
3. Risk Level 1 dischargers shall implement good housekeeping for vehicle storage and maintenance, which, at a minimum, shall consist of the following:
 - a. Prevent oil, grease, or fuel to leak in to the ground, storm drains or surface waters.
 - b. Place all equipment or vehicles, which are to be fueled, maintained and stored in a designated area fitted with appropriate BMPs.
 - c. Clean leaks immediately and disposing of leaked materials properly.
4. Risk Level 1 dischargers shall implement good housekeeping for landscape materials, which, at a minimum, shall consist of the following:
 - a. Contain stockpiled materials such as mulches and topsoil when they are not actively being used.
 - b. Contain fertilizers and other landscape materials when they are not actively being used.
 - c. Discontinue the application of any erodible landscape material within 2 days before a forecasted rain event or during periods of precipitation.
 - d. Apply erodible landscape material at quantities and application rates according to manufacture recommendations or based on written specifications by knowledgeable and experienced field personnel.
 - e. Stack erodible landscape material on pallets and covering or storing such materials when not being used or applied.
5. Risk Level 1 dischargers shall conduct an assessment and create a list of potential pollutant sources and identify any areas of the site where additional BMPs are necessary to reduce or prevent pollutants in storm water discharges and authorized non-storm water discharges. This potential pollutant list shall be kept with the SWPPP and shall identify

all non-visible pollutants which are known, or should be known, to occur on the construction site. At a minimum, when developing BMPs, Risk Level 1 dischargers shall do the following:

- a. Consider the quantity, physical characteristics (e.g., liquid, powder, solid), and locations of each potential pollutant source handled, produced, stored, recycled, or disposed of at the site.
 - b. Consider the degree to which pollutants associated with those materials may be exposed to and mobilized by contact with storm water.
 - c. Consider the direct and indirect pathways that pollutants may be exposed to storm water or authorized non-storm water discharges. This shall include an assessment of past spills or leaks, non-storm water discharges, and discharges from adjoining areas.
 - d. Ensure retention of sampling, visual observation, and inspection records.
 - e. Ensure effectiveness of existing BMPs to reduce or prevent pollutants in storm water discharges and authorized non-storm water discharges.
6. Risk Level 1 dischargers shall implement good housekeeping measures on the construction site to control the air deposition of site materials and from site operations. Such particulates can include, but are not limited to, sediment, nutrients, trash, metals, bacteria, oil and grease and organics.

C. Non-Storm Water Management

1. Risk Level 1 dischargers shall implement measures to control all non-storm water discharges during construction.
2. Risk Level 1 dischargers shall wash vehicles in such a manner as to prevent non-storm water discharges to surface waters or MS4 drainage systems.
3. Risk Level 1 dischargers shall clean streets in such a manner as to prevent unauthorized non-storm water discharges from reaching surface water or MS4 drainage systems.

D. Erosion Control

1. Risk Level 1 dischargers shall implement effective wind erosion control.
2. Risk Level 1 dischargers shall provide effective soil cover for inactive¹ areas and all finished slopes, open space, utility backfill, and completed lots.
3. Risk Level 1 dischargers shall limit the use of plastic materials when more sustainable, environmentally friendly alternatives exist. Where plastic materials are deemed necessary, the discharger shall consider the use of plastic materials resistant to solar degradation.

E. Sediment Controls

1. Risk Level 1 dischargers shall establish and maintain effective perimeter controls and stabilize all construction entrances and exits to sufficiently control erosion and sediment discharges from the site.
2. On sites where sediment basins are to be used, Risk Level 1 dischargers shall, at minimum, design sediment basins according to the method provided in CASQA's Construction BMP Guidance Handbook.

F. Run-on and Runoff Controls

Risk Level 1 dischargers shall effectively manage all run-on, all runoff within the site and all runoff that discharges off the site. Run-on from off site shall be directed away from all disturbed areas or shall collectively be in compliance with the effluent limitations in this General Permit.

G. Inspection, Maintenance and Repair

1. Risk Level 1 dischargers shall ensure that all inspection, maintenance repair and sampling activities at the project location shall be performed or supervised by a Qualified SWPPP Practitioner (QSP) representing the discharger. The QSP may delegate any or all of these activities to an employee trained to do the task(s) appropriately, but shall ensure adequate deployment.
2. Risk Level 1 dischargers shall perform weekly inspections and observations, and at least once each 24-hour period during extended

¹ Inactive areas of construction are areas of construction activity that have been disturbed and are not scheduled to be re-disturbed for at least 14 days.

storm events, to identify and record BMPs that need maintenance to operate effectively, that have failed, or that could fail to operate as intended. Inspectors shall be the QSP or be trained by the QSP.

3. Upon identifying failures or other shortcomings, as directed by the QSP, Risk Level 1 dischargers shall begin implementing repairs or design changes to BMPs within 72 hours of identification and complete the changes as soon as possible.
4. For each inspection required, Risk Level 1 dischargers shall complete an inspection checklist, using a form provided by the State Water Board or Regional Water Board or in an alternative format.
5. Risk Level 1 dischargers shall ensure that checklists shall remain onsite with the SWPPP and at a minimum, shall include:
 - a. Inspection date and date the inspection report was written.
 - b. Weather information, including presence or absence of precipitation, estimate of beginning of qualifying storm event, duration of event, time elapsed since last storm, and approximate amount of rainfall in inches.
 - c. Site information, including stage of construction, activities completed, and approximate area of the site exposed.
 - d. A description of any BMPs evaluated and any deficiencies noted.
 - e. If the construction site is safely accessible during inclement weather, list the observations of all BMPs: erosion controls, sediment controls, chemical and waste controls, and non-storm water controls. Otherwise, list the results of visual inspections at all relevant outfalls, discharge points, downstream locations and any projected maintenance activities.
 - f. Report the presence of noticeable odors or of any visible sheen on the surface of any discharges.
 - g. Any corrective actions required, including any necessary changes to the SWPPP and the associated implementation dates.
 - h. Photographs taken during the inspection, if any.
 - i. Inspector's name, title, and signature.

H. Rain Event Action Plan

Not required for Risk Level 1 dischargers.

I. Risk Level 1 Monitoring and Reporting Requirements

Table 1- Summary of Monitoring Requirements

Risk Level	Visual Inspections					Sample Collection	
	Quarterly Non-storm Water Discharge	Pre-storm Event		Daily Storm BMP	Post Storm	Storm Water Discharge	Receiving Water
		Baseline	REAP				
1	X	X		X	X		

1. Construction Site Monitoring Program Requirements

- a. Pursuant to Water Code Sections 13383 and 13267, all dischargers subject to this General Permit shall develop and implement a written site-specific Construction Site Monitoring Program (CSMP) in accordance with the requirements of this Section. The CSMP shall include all monitoring procedures and instructions, location maps, forms, and checklists as required in this section. The CSMP shall be developed prior to the commencement of construction activities, and revised as necessary to reflect project revisions. The CSMP shall be a part of the Storm Water Pollution Prevention Plan (SWPPP), included as an appendix or separate SWPPP chapter.
- b. Existing dischargers registered under the State Water Board Order No. 99-08-DWQ shall make and implement necessary revisions to their Monitoring Programs to reflect the changes in this General Permit in a timely manner, but no later than July 1, 2010. Existing dischargers shall continue to implement their existing Monitoring Programs in compliance with State Water Board Order No. 99-08-DWQ until the necessary revisions are completed according to the schedule above.
- c. When a change of ownership occurs for all or any portion of the construction site prior to completion or final stabilization, the new discharger shall comply with these requirements as of the date the ownership change occurs.

2. Objectives

The CSMP shall be developed and implemented to address the following objectives:

- a. To demonstrate that the site is in compliance with the Discharge Prohibitions;

- b. To determine whether non-visible pollutants are present at the construction site and are causing or contributing to exceedances of water quality objectives;
 - c. To determine whether immediate corrective actions, additional Best Management Practice (BMP) implementation, or SWPPP revisions are necessary to reduce pollutants in storm water discharges and authorized non-storm water discharges; and
 - d. To determine whether BMPs included in the SWPPP are effective in preventing or reducing pollutants in storm water discharges and authorized non-storm water discharges.
- 3. Risk Level 1 - Visual Monitoring (Inspection) Requirements for Qualifying Rain Events**
- a. Risk Level 1 dischargers shall visually observe (inspect) storm water discharges at all discharge locations within two business days (48 hours) after each qualifying rain event.
 - b. Risk Level 1 dischargers shall visually observe (inspect) the discharge of stored or contained storm water that is derived from and discharged subsequent to a qualifying rain event producing precipitation of $\frac{1}{2}$ inch or more at the time of discharge. Stored or contained storm water that will likely discharge after operating hours due to anticipated precipitation shall be observed prior to the discharge during operating hours.
 - c. Risk Level 1 dischargers shall conduct visual observations (inspections) during business hours only.
 - d. Risk Level 1 dischargers shall record the time, date and rain gauge reading of all qualifying rain events.
 - e. Within 2 business days (48 hours) prior to each qualifying rain event, Risk Level 1 dischargers shall visually observe (inspect):
 - i. All storm water drainage areas to identify any spills, leaks, or uncontrolled pollutant sources. If needed, the discharger shall implement appropriate corrective actions.
 - ii. All BMPs to identify whether they have been properly implemented in accordance with the SWPPP. If needed, the discharger shall implement appropriate corrective actions.

- iii. Any storm water storage and containment areas to detect leaks and ensure maintenance of adequate freeboard.
- f. For the visual observations (inspections) described in e.i and e.iii above, Risk Level 1 dischargers shall observe the presence or absence of floating and suspended materials, a sheen on the surface, discolorations, turbidity, odors, and source(s) of any observed pollutants.
- g. Within two business days (48 hours) after each qualifying rain event, Risk Level 1 dischargers shall conduct post rain event visual observations (inspections) to (1) identify whether BMPs were adequately designed, implemented, and effective, and (2) identify additional BMPs and revise the SWPPP accordingly.
- h. Risk Level 1 dischargers shall maintain on-site records of all visual observations (inspections), personnel performing the observations, observation dates, weather conditions, locations observed, and corrective actions taken in response to the observations.

4. Risk Level 1 – Visual Observation Exemptions

- a. Risk Level 1 dischargers shall be prepared to conduct visual observation (inspections) until the minimum requirements of Section I.3 above are completed. Risk Level 1 dischargers are not required to conduct visual observation (inspections) under the following conditions:
 - i. During dangerous weather conditions such as flooding and electrical storms.
 - ii. Outside of scheduled site business hours.
- b. If no required visual observations (inspections) are collected due to these exceptions, Risk Level 1 dischargers shall include an explanation in their SWPPP and in the Annual Report documenting why the visual observations (inspections) were not conducted.

5. Risk Level 1 – Monitoring Methods

Risk Level 1 dischargers shall include a description of the visual observation locations, visual observation procedures, and visual observation follow-up and tracking procedures in the CSMP.

6. Risk Level 1 – Non-Storm Water Discharge Monitoring Requirements

- a. Visual Monitoring Requirements:
 - i. Risk Level 1 dischargers shall visually observe (inspect) each drainage area for the presence of (or indications of prior) unauthorized and authorized non-storm water discharges and their sources.
 - ii. Risk Level 1 dischargers shall conduct one visual observation (inspection) quarterly in each of the following periods: January-March, April-June, July-September, and October-December. Visual observation (inspections) are only required during daylight hours (sunrise to sunset).
 - iii. Risk Level 1 dischargers shall ensure that visual observations (inspections) document the presence or evidence of any non-storm water discharge (authorized or unauthorized), pollutant characteristics (floating and suspended material, sheen, discoloration, turbidity, odor, etc.), and source. Risk Level 1 dischargers shall maintain on-site records indicating the personnel performing the visual observation (inspections), the dates and approximate time each drainage area and non-storm water discharge was observed, and the response taken to eliminate unauthorized non-storm water discharges and to reduce or prevent pollutants from contacting non-storm water discharges.

7. Risk Level 1 – Non-Visible Pollutant Monitoring Requirements

- a. Risk Level 1 dischargers shall collect one or more samples during any breach, malfunction, leakage, or spill observed during a visual inspection which could result in the discharge of pollutants to surface waters that would not be visually detectable in storm water.
- b. Risk Level 1 dischargers shall ensure that water samples are large enough to characterize the site conditions.
- c. Risk Level 1 dischargers shall collect samples at all discharge locations that can be safely accessed.
- d. Risk Level 1 dischargers shall collect samples during the first two hours of discharge from rain events that occur during business hours and which generate runoff.
- e. Risk Level 1 dischargers shall analyze samples for all non-visible pollutant parameters (if applicable) - parameters indicating the

presence of pollutants identified in the pollutant source assessment required (Risk Level 1 dischargers shall modify their CSMPs to address these additional parameters in accordance with any updated SWPPP pollutant source assessment).

- f. Risk Level 1 dischargers shall collect a sample of storm water that has not come in contact with the disturbed soil or the materials stored or used on-site (uncontaminated sample) for comparison with the discharge sample.
- g. Risk Level 1 dischargers shall compare the uncontaminated sample to the samples of discharge using field analysis or through laboratory analysis.²
- h. Risk Level 1 dischargers shall keep all field /or analytical data in the SWPPP document.

8. Risk Level 1 – Particle Size Analysis for Project Risk Justification

Risk Level 1 dischargers justifying an alternative project risk shall report a soil particle size analysis used to determine the RUSLE K-Factor. ASTM D-422 (Standard Test Method for Particle-Size Analysis of Soils), as revised, shall be used to determine the percentages of sand, very fine sand, silt, and clay on the site.

9. Risk Level 1 – Records

Risk Level 1 dischargers shall retain records of all storm water monitoring information and copies of all reports (including Annual Reports) for a period of at least three years. Risk Level 1 dischargers shall retain all records on-site while construction is ongoing. These records include:

- a. The date, place, time of facility inspections, sampling, visual observation (inspections), and/or measurements, including precipitation.
- b. The individual(s) who performed the facility inspections, sampling, visual observation (inspections), and or measurements.
- c. The date and approximate time of analyses.
- d. The individual(s) who performed the analyses.

² For laboratory analysis, all sampling, sample preservation, and analyses must be conducted according to test procedures under 40 CFR Part 136. Field discharge samples shall be collected and analyzed according to the specifications of the manufacturer of the sampling devices employed.

- e. A summary of all analytical results from the last three years, the method detection limits and reporting units, and the analytical techniques or methods used.
- f. Rain gauge readings from site inspections.
- g. Quality assurance/quality control records and results.
- h. Non-storm water discharge inspections and visual observation (inspections) and storm water discharge visual observation records (see Sections I.3 and I.6 above).
- i. Visual observation and sample collection exception records (see Section I.4 above).
- j. The records of any corrective actions and follow-up activities that resulted from analytical results, visual observation (inspections), or inspections.

ATTACHMENT D RISK LEVEL 2 REQUIREMENTS

A. Effluent Standards

[These requirements are the same as those in the General Permit order.]

1. Narrative – Risk Level 2 dischargers shall comply with the narrative effluent standards listed below:
 - a. Storm water discharges and authorized non-storm water discharges regulated by this General Permit shall not contain a hazardous substance equal to or in excess of reportable quantities established in 40 C.F.R. §§ 117.3 and 302.4, unless a separate NPDES Permit has been issued to regulate those discharges.
 - b. Dischargers shall minimize or prevent pollutants in storm water discharges and authorized non-storm water discharges through the use of controls, structures, and management practices that achieve BAT for toxic and non-conventional pollutants and BCT for conventional pollutants.
2. Numeric – Risk level 2 dischargers are subject to a pH NAL of 6.5-8.5, and a turbidity NAL of 250 NTU.

B. Good Site Management "Housekeeping"

1. Risk Level 2 dischargers shall implement good site management (i.e., "housekeeping") measures for construction materials that could potentially be a threat to water quality if discharged. At a minimum, Risk Level 2 dischargers shall implement the following good housekeeping measures:
 - a. Conduct an inventory of the products used and/or expected to be used and the end products that are produced and/or expected to be produced. This does not include materials and equipment that are designed to be outdoors and exposed to environmental conditions (i.e. poles, equipment pads, cabinets, conductors, insulators, bricks, etc.).
 - b. Cover and berm loose stockpiled construction materials that are not actively being used (i.e. soil, spoils, aggregate, fly-ash, stucco, hydrated lime, etc.).

- c. Store chemicals in watertight containers (with appropriate secondary containment to prevent any spillage or leakage) or in a storage shed (completely enclosed).
 - d. Minimize exposure of construction materials to precipitation. This does not include materials and equipment that are designed to be outdoors and exposed to environmental conditions (i.e. poles, equipment pads, cabinets, conductors, insulators, bricks, etc.).
 - e. Implement BMPs to prevent the off-site tracking of loose construction and landscape materials.
2. Risk Level 2 dischargers shall implement good housekeeping measures for waste management, which, at a minimum, shall consist of the following:
- a. Prevent disposal of any rinse or wash waters or materials on impervious or pervious site surfaces or into the storm drain system.
 - b. Ensure the containment of sanitation facilities (e.g., portable toilets) to prevent discharges of pollutants to the storm water drainage system or receiving water.
 - c. Clean or replace sanitation facilities and inspecting them regularly for leaks and spills.
 - d. Cover waste disposal containers at the end of every business day and during a rain event.
 - e. Prevent discharges from waste disposal containers to the storm water drainage system or receiving water.
 - f. Contain and securely protect stockpiled waste material from wind and rain at all times unless actively being used.
 - g. Implement procedures that effectively address hazardous and non-hazardous spills.
 - h. Develop a spill response and implementation element of the SWPPP prior to commencement of construction activities. The SWPPP shall require:
 - i. Equipment and materials for cleanup of spills shall be available on site and that spills and leaks shall be cleaned up immediately and disposed of properly.

- ii. Appropriate spill response personnel are assigned and trained.
 - i. Ensure the containment of concrete washout areas and other washout areas that may contain additional pollutants so there is no discharge into the underlying soil and onto the surrounding areas.
3. Risk Level 2 dischargers shall implement good housekeeping for vehicle storage and maintenance, which, at a minimum, shall consist of the following:
 - a. Prevent oil, grease, or fuel to leak in to the ground, storm drains or surface waters.
 - b. Place all equipment or vehicles, which are to be fueled, maintained and stored in a designated area fitted with appropriate BMPs.
 - c. Clean leaks immediately and disposing of leaked materials properly.
4. Risk Level 2 dischargers shall implement good housekeeping for landscape materials, which, at a minimum, shall consist of the following:
 - a. Contain stockpiled materials such as mulches and topsoil when they are not actively being used.
 - b. Contain all fertilizers and other landscape materials when they are not actively being used.
 - c. Discontinue the application of any erodible landscape material within 2 days before a forecasted rain event or during periods of precipitation.
 - d. Apply erodible landscape material at quantities and application rates according to manufacture recommendations or based on written specifications by knowledgeable and experienced field personnel.
 - e. Stack erodible landscape material on pallets and covering or storing such materials when not being used or applied.
5. Risk Level 2 dischargers shall conduct an assessment and create a list of potential pollutant sources and identify any areas of the site where additional BMPs are necessary to reduce or prevent pollutants in storm water discharges and authorized non-storm water discharges. This potential pollutant list shall be kept with the SWPPP and shall identify

all non-visible pollutants which are known, or should be known, to occur on the construction site. At a minimum, when developing BMPs, Risk Level 2 dischargers shall do the following:

- a. Consider the quantity, physical characteristics (e.g., liquid, powder, solid), and locations of each potential pollutant source handled, produced, stored, recycled, or disposed of at the site.
 - b. Consider the degree to which pollutants associated with those materials may be exposed to and mobilized by contact with storm water.
 - c. Consider the direct and indirect pathways that pollutants may be exposed to storm water or authorized non-storm water discharges. This shall include an assessment of past spills or leaks, non-storm water discharges, and discharges from adjoining areas.
 - d. Ensure retention of sampling, visual observation, and inspection records.
 - e. Ensure effectiveness of existing BMPs to reduce or prevent pollutants in storm water discharges and authorized non-storm water discharges.
6. Risk Level 2 dischargers shall implement good housekeeping measures on the construction site to control the air deposition of site materials and from site operations. Such particulates can include, but are not limited to, sediment, nutrients, trash, metals, bacteria, oil and grease and organics.
7. **Additional Risk Level 2 Requirement:** Risk Level 2 dischargers shall document all housekeeping BMPs in the SWPPP and REAP(s) in accordance with the nature and phase of the construction project. Construction phases at traditional land development projects include Grading and Land Development Phase, Streets and Utilities, or Vertical Construction for traditional land development projects.

C. Non-Storm Water Management

1. Risk Level 2 dischargers shall implement measures to control all non-storm water discharges during construction.
2. Risk Level 2 dischargers shall wash vehicles in such a manner as to prevent non-storm water discharges to surface waters or MS4 drainage systems.

3. Risk Level 2 dischargers shall clean streets in such a manner as to prevent unauthorized non-storm water discharges from reaching surface water or MS4 drainage systems.

D. Erosion Control

1. Risk Level 2 dischargers shall implement effective wind erosion control.
2. Risk Level 2 dischargers shall provide effective soil cover for inactive¹ areas and all finished slopes, open space, utility backfill, and completed lots.
3. Risk Level 2 dischargers shall limit the use of plastic materials when more sustainable, environmentally friendly alternatives exist. Where plastic materials are deemed necessary, the discharger shall consider the use of plastic materials resistant to solar degradation.

E. Sediment Controls

1. Risk Level 2 dischargers shall establish and maintain effective perimeter controls and stabilize all construction entrances and exits to sufficiently control erosion and sediment discharges from the site.
2. On sites where sediment basins are to be used, Risk Level 2 dischargers shall, at minimum, design sediment basins according to the method provided in CASQA’s Construction BMP Guidance Handbook.
3. **Additional Risk Level 2 Requirement:** Risk Level 2 dischargers shall implement appropriate erosion control BMPs (runoff control and soil stabilization) in conjunction with sediment control BMPs for areas under active² construction.
4. **Additional Risk Level 2 Requirement:** Risk Level 2 dischargers shall apply linear sediment controls along the toe of the slope, face of the slope, and at the grade breaks of exposed slopes to comply with sheet flow lengths³ in accordance with Table 1.

Table 1 - Critical Slope/Sheet Flow Length Combinations

Slope Percentage	Sheet flow length not
------------------	-----------------------

¹ Inactive areas of construction are areas of construction activity that have been disturbed and are not scheduled to be re-disturbed for at least 14 days.

² Active areas of construction are areas undergoing land surface disturbance. This includes construction activity during the preliminary stage, mass grading stage, streets and utilities stage and the vertical construction stage.

³ Sheet flow length is the length that shallow, low velocity flow travels across a site.

	to exceed
0-25% 20	feet
25-50% 15	feet
Over 50%	10 feet

5. **Additional Risk Level 2 Requirement:** Risk Level 2 dischargers shall ensure that construction activity traffic to and from the project is limited to entrances and exits that employ effective controls to prevent offsite tracking of sediment.
6. **Additional Risk Level 2 Requirement:** Risk Level 2 dischargers shall ensure that all storm drain inlets and perimeter controls, runoff control BMPs, and pollutant controls at entrances and exits (e.g. tire washoff locations) are maintained and protected from activities that reduce their effectiveness.
7. **Additional Risk Level 2 Requirement:** Risk Level 2 dischargers shall inspect on a daily basis all immediate access roads daily. At a minimum daily (when necessary) and prior to any rain event, the discharger shall remove any sediment or other construction activity-related materials that are deposited on the roads (by vacuuming or sweeping).

F. Run-on and Run-off Controls

Risk Level 2 dischargers shall effectively manage all run-on, all runoff within the site and all runoff that discharges off the site. Run-on from off site shall be directed away from all disturbed areas or shall collectively be in compliance with the effluent limitations in this General Permit.

G. Inspection, Maintenance and Repair

1. Risk Level 2 dischargers shall ensure that all inspection, maintenance repair and sampling activities at the project location shall be performed or supervised by a Qualified SWPPP Practitioner (QSP) representing the discharger. The QSP may delegate any or all of these activities to an employee appropriately trained to do the task(s).
2. Risk Level 2 dischargers shall perform weekly inspections and observations, and at least once each 24-hour period during extended storm events, to identify and record BMPs that need maintenance to operate effectively, that have failed, or that could fail to operate as intended. Inspectors shall be the QSP or be trained by the QSP.
3. Upon identifying failures or other shortcomings, as directed by the QSP, Risk Level 2 dischargers shall begin implementing repairs or

design changes to BMPs within 72 hours of identification and complete the changes as soon as possible.

4. For each inspection required, Risk Level 2 dischargers shall complete an inspection checklist, using a form provided by the State Water Board or Regional Water Board or in an alternative format.
5. Risk Level 2 dischargers shall ensure that checklists shall remain onsite with the SWPPP and at a minimum, shall include:
 - a. Inspection date and date the inspection report was written.
 - b. Weather information, including presence or absence of precipitation, estimate of beginning of qualifying storm event, duration of event, time elapsed since last storm, and approximate amount of rainfall in inches.
 - c. Site information, including stage of construction, activities completed, and approximate area of the site exposed.
 - d. A description of any BMPs evaluated and any deficiencies noted.
 - e. If the construction site is safely accessible during inclement weather, list the observations of all BMPs: erosion controls, sediment controls, chemical and waste controls, and non-storm water controls. Otherwise, list the results of visual inspections at all relevant outfalls, discharge points, downstream locations and any projected maintenance activities.
 - f. Report the presence of noticeable odors or of any visible sheen on the surface of any discharges.
 - g. Any corrective actions required, including any necessary changes to the SWPPP and the associated implementation dates.
 - h. Photographs taken during the inspection, if any.
 - i. Inspector's name, title, and signature.

H. Rain Event Action Plan

1. **Additional Risk Level 2 Requirement:** The discharger shall ensure a QSP develop a Rain Event Action Plan (REAP) 48 hours prior to any likely precipitation event. A likely precipitation event is any weather pattern that is forecast to have a 50% or greater probability of producing precipitation in the project area. The discharger shall

ensure a QSP obtain a printed copy of precipitation forecast information from the National Weather Service Forecast Office (e.g., by entering the zip code of the project's location at <http://www.srh.noaa.gov/forecast>).

2. **Additional Risk Level 2 Requirement:** The discharger shall ensure a QSP develop the REAPs for all phases of construction (i.e., Grading and Land Development, Streets and Utilities, Vertical Construction, Final Landscaping and Site Stabilization).
3. **Additional Risk Level 2 Requirement:** The discharger shall ensure a QSP ensure that the REAP include, at a minimum, the following site information:
 - a. Site Address
 - b. Calculated Risk Level (2 or 3)
 - c. Site Storm Water Manager Information including the name, company, and 24-hour emergency telephone number
 - d. Erosion and Sediment Control Provider information including the name, company, and 24-hour emergency telephone number
 - e. Storm Water Sampling Agent information including the name, company, and 24-hour emergency telephone number
4. **Additional Risk Level 2 Requirement:** The discharger shall ensure a QSP include in the REAP, at a minimum, the following project phase information:
 - a. Activities associated with each construction phase
 - b. Trades active on the construction site during each construction phase
 - c. Trade contractor information
 - d. Suggested actions for each project phase
5. **Additional Risk Level 2 Requirement:** The discharger shall ensure a QSP develop additional REAPs for project sites where construction activities are indefinitely halted or postponed (Inactive Construction). At a minimum, Inactive Construction REAPs must include:
 - a. Site Address
 - b. Calculated Risk Level (2 or 3)
 - c. Site Storm Water Manager Information including the name, company, and 24-hour emergency telephone number
 - d. Erosion and Sediment Control Provider information including the name, company, and 24-hour emergency telephone number
 - e. Storm Water Sampling Agent information including the name, company, and 24-hour emergency telephone number

- f. Trades active on site during Inactive Construction
 - g. Trade contractor information
 - h. Suggested actions for inactive construction sites
6. **Additional Risk Level 2 Requirement:** The discharger shall ensure a QSP begin implementation and make the REAP available onsite no later than 24 hours prior to the likely precipitation event.
7. **Additional Risk Level 2 Requirement:** The discharger shall ensure a QSP maintain onsite a paper copy of each REAP onsite in compliance with the record retention requirements of the Special Provisions in this General Permit.

I. Risk Level 2 Monitoring and Reporting Requirements

Table 2- Summary of Monitoring Requirements

Risk Level	Visual Inspections					Sample Collection	
	Quarterly Non-storm Water Discharge	Pre-storm Event		Daily Storm BMP	Post Storm	Storm Water Discharge	Receiving Water
		Baseline	REAP				
2	X	X	X	X	X	X	

1. Construction Site Monitoring Program Requirements

- a. Pursuant to Water Code Sections 13383 and 13267, all dischargers subject to this General Permit shall develop and implement a written site-specific Construction Site Monitoring Program (CSMP) in accordance with the requirements of this Section. The CSMP shall include all monitoring procedures and instructions, location maps, forms, and checklists as required in this section. The CSMP shall be developed prior to the commencement of construction activities, and revised as necessary to reflect project revisions. The CSMP shall be a part of the Storm Water Pollution Prevention Plan (SWPPP), included as an appendix or separate SWPPP chapter.
- b. Existing dischargers registered under the State Water Board Order No. 99-08-DWQ shall make and implement necessary revisions to their Monitoring Program to reflect the changes in this General Permit in a timely manner, but no later than July 1, 2010. Existing dischargers shall continue to implement their existing Monitoring Programs in compliance with State Water Board Order No. 99-08-DWQ until the necessary revisions are completed according to the schedule above.
- c. When a change of ownership occurs for all or any portion of the construction site prior to completion or final stabilization, the new discharger shall comply with these requirements as of the date the ownership change occurs.

2. Objectives

The CSMP shall be developed and implemented to address the following objectives:

- a. To demonstrate that the site is in compliance with the Discharge Prohibitions and applicable Numeric Action Levels (NALs)/Numeric Effluent Limitations (NELs) of this General Permit.
 - b. To determine whether non-visible pollutants are present at the construction site and are causing or contributing to exceedances of water quality objectives.
 - c. To determine whether immediate corrective actions, additional Best Management Practice (BMP) implementation, or SWPPP revisions are necessary to reduce pollutants in storm water discharges and authorized non-storm water discharges.
 - d. To determine whether BMPs included in the SWPPP/Rain Event Action Plan (REAP) are effective in preventing or reducing pollutants in storm water discharges and authorized non-storm water discharges.
- 3. Risk Level 2 – Visual Monitoring (Inspection) Requirements for Qualifying Rain Events**
- a. Risk Level 2 dischargers shall visually observe (inspect) storm water discharges at all discharge locations within two business days (48 hours) after each qualifying rain event.
 - b. Risk Level 2 dischargers shall visually observe (inspect) the discharge of stored or contained storm water that is derived from and discharged subsequent to a qualifying rain event producing precipitation of ½ inch or more at the time of discharge. Stored or contained storm water that will likely discharge after operating hours due to anticipated precipitation shall be observed prior to the discharge during operating hours.
 - c. Risk Level 2 dischargers shall conduct visual observations (inspections) during business hours only.
 - d. Risk Level 2 dischargers shall record the time, date and rain gauge reading of all qualifying rain events.
 - e. Within 2 business days (48 hours) prior to each qualifying rain event, Risk Level 2 dischargers shall visually observe (inspect):
 - i. all storm water drainage areas to identify any spills, leaks, or uncontrolled pollutant sources. If needed, the discharger shall implement appropriate corrective actions.

- ii. all BMPs to identify whether they have been properly implemented in accordance with the SWPPP/REAP. If needed, the discharger shall implement appropriate corrective actions.
 - iii. any storm water storage and containment areas to detect leaks and ensure maintenance of adequate freeboard.
- f. For the visual observations (inspections) described in c.i and c.iii above, Risk Level 2 dischargers shall observe the presence or absence of floating and suspended materials, a sheen on the surface, discolorations, turbidity, odors, and source(s) of any observed pollutants.
 - g. Within two business days (48 hours) after each qualifying rain event, Risk Level 2 dischargers shall conduct post rain event visual observations (inspections) to (1) identify whether BMPs were adequately designed, implemented, and effective, and (2) identify additional BMPs and revise the SWPPP accordingly.
 - h. Risk Level 2 dischargers shall maintain on-site records of all visual observations (inspections), personnel performing the observations, observation dates, weather conditions, locations observed, and corrective actions taken in response to the observations.

4. Risk Level 2 – Water Quality Sampling and Analysis

- a. Risk Level 2 dischargers shall collect storm water grab samples from sampling locations, as defined in Section I.5. The storm water grab sample(s) obtained shall be representative of the flow and characteristics of the discharge.
- b. At minimum, Risk Level 2 dischargers shall collect 3 samples per day of the qualifying event.
- c. Risk Level 2 dischargers shall ensure that the grab samples collected of stored or contained storm water are from discharges subsequent to a qualifying rain event (producing precipitation of ½ inch or more at the time of discharge).

Storm Water Effluent Monitoring Requirements

- d. Risk Level 2 dischargers shall analyze their effluent samples for:
 - i. pH and turbidity.

- ii. Any additional parameters for which monitoring is required by the Regional Water Board.

5. Risk Level 2 – Storm Water Discharge Water Quality Sampling Locations

Effluent Sampling Locations

- a. Risk Level 2 dischargers shall perform sampling and analysis of storm water discharges to characterize discharges associated with construction activity from the entire project disturbed area.
- b. Risk Level 2 dischargers shall collect effluent samples at all discharge points where storm water is discharged off-site.
- c. Risk Level 2 dischargers shall ensure that storm water discharge collected and observed represent⁴ the effluent in each drainage area based on visual observation of the water and upstream conditions.
- d. Risk Level 2 dischargers shall monitor and report site run-on from surrounding areas if there is reason to believe run-on may contribute to an exceedance of NALs or NELs.
- e. Risk Level 2 dischargers who deploy an ATS on their site, or a portion on their site, shall collect ATS effluent samples and measurements from the discharge pipe or another location representative of the nature of the discharge.
- f. Risk Level 2 dischargers shall select analytical test methods from the list provided in Table 3 below.
- g. All storm water sample collection preservation and handling shall be conducted in accordance with Section I.7 “Storm Water Sample Collection and Handling Instructions” below.

6. Risk Level 2 – Visual Observation and Sample Collection Exemptions

- a. Risk Level 2 dischargers shall be prepared to collect samples and conduct visual observation (inspections) until the minimum requirements of Sections I.3 and I.4 above are completed. Risk

⁴ For example, if there has been concrete work recently in an area, or drywall scrap is exposed to the rain, a pH sample shall be taken of drainage from the relevant work area. Similarly, if sediment laden water is flowing through some parts of a silt fence, samples shall be taken of the sediment-laden water even if most water flowing through the fence is clear.

Level 2 dischargers are not required to physically collect samples or conduct visual observation (inspections) under the following conditions:

- i. During dangerous weather conditions such as flooding and electrical storms.
 - ii. Outside of scheduled site business hours.
- b. If no required samples or visual observation (inspections) are collected due to these exceptions, Risk Level 2 dischargers shall include an explanation in their SWPPP and in the Annual Report documenting why the sampling or visual observation (inspections) were not conducted.

7. Risk Level 2 – Storm Water Sample Collection and Handling Instructions

- a. Risk Level 2 dischargers shall refer to Table 3 below for test methods, detection limits, and reporting units.
- b. Risk Level 2 dischargers shall ensure that testing laboratories will receive samples within 48 hours of the physical sampling (unless otherwise required by the laboratory), and shall use only the sample containers provided by the laboratory to collect and store samples.
- c. Risk Level 2 dischargers shall designate and train personnel to collect, maintain, and ship samples in accordance with the Surface Water Ambient Monitoring Program's (SWAMP) 2008 Quality Assurance Program Plan (QAPrP).⁵

8. Risk Level 2 – Monitoring Methods

- a. Risk Level 2 dischargers shall include a description of the following items in the CSMP:
 - i. Visual observation locations, visual observation procedures, and visual observation follow-up and tracking procedures.
 - ii. Sampling locations, and sample collection and handling procedures. This shall include detailed procedures for sample

⁵ Additional information regarding SWAMP's QAPrP and QAMP can be found at

http://www.waterboards.ca.gov/water_issues/programs/swamp/.

QAPrP: http://www.waterboards.ca.gov/water_issues/programs/swamp/docs/qapp/swamp_qapp_master090108a.pdf.

QAMP: http://www.waterboards.ca.gov/water_issues/programs/swamp/qamp.shtml.

collection, storage, preservation, and shipping to the testing lab to assure that consistent quality control and quality assurance is maintained. Dischargers shall attach to the monitoring program an example Chain of Custody form used when handling and shipping samples.

- iii. Identification of the analytical methods and related method detection limits (if applicable) for each parameter required in Section I.4 above.
- b. Risk Level 2 dischargers shall ensure that all sampling and sample preservation are in accordance with the current edition of "Standard Methods for the Examination of Water and Wastewater" (American Public Health Association). All monitoring instruments and equipment (including a discharger's own field instruments for measuring pH and turbidity) should be calibrated and maintained in accordance with manufacturers' specifications to ensure accurate measurements. Risk Level 2 dischargers shall ensure that all laboratory analyses are conducted according to test procedures under 40 CFR Part 136, unless other test procedures have been specified in this General Permit or by the Regional Water Board. With the exception of field analysis conducted by the discharger for turbidity and pH, all analyses should be sent to and conducted at a laboratory certified for such analyses by the State Department of Health Services. Risk Level 2 dischargers shall conduct their own field analysis of pH and may conduct their own field analysis of turbidity if the discharger has sufficient capability (qualified and trained employees, properly calibrated and maintained field instruments, etc.) to adequately perform the field analysis.

9. Risk Level 2 – Analytical Methods

- a. Risk Level 2 dischargers shall refer to Table 3 below for test methods, detection limits, and reporting units.
- b. **pH:** Risk Level 2 dischargers shall perform pH analysis on-site with a calibrated pH meter or a pH test kit. Risk Level 2 dischargers shall record pH monitoring results on paper and retain these records in accordance with Section I.14, below.
- c. **Turbidity:** Risk Level 2 dischargers shall perform turbidity analysis using a calibrated turbidity meter (turbidimeter), either on-site or at an accredited lab. Acceptable test methods include Standard Method 2130 or USEPA Method 180.1. The results will be recorded in the site log book in Nephelometric Turbidity Units (NTU).

10. Risk Level 2 - Non-Storm Water Discharge Monitoring Requirements

- a. Visual Monitoring Requirements:
 - i. Risk Level 2 dischargers shall visually observe (inspect) each drainage area for the presence of (or indications of prior) unauthorized and authorized non-storm water discharges and their sources.
 - ii. Risk Level 2 dischargers shall conduct one visual observation (inspection) quarterly in each of the following periods: January-March, April-June, July-September, and October-December. Visual observation (inspections) are only required during daylight hours (sunrise to sunset).
 - iii. Risk Level 2 dischargers shall ensure that visual observations (inspections) document the presence or evidence of any non-storm water discharge (authorized or unauthorized), pollutant characteristics (floating and suspended material, sheen, discoloration, turbidity, odor, etc.), and source. Risk Level 2 dischargers shall maintain on-site records indicating the personnel performing the visual observation (inspections), the dates and approximate time each drainage area and non-storm water discharge was observed, and the response taken to eliminate unauthorized non-storm water discharges and to reduce or prevent pollutants from contacting non-storm water discharges.
- b. Effluent Sampling Locations:
 - i. Risk Level 2 dischargers shall sample effluent at all discharge points where non-storm water and/or authorized non-storm water is discharged off-site.
 - ii. Risk Level 2 dischargers shall send all non-storm water sample analyses to a laboratory certified for such analyses by the State Department of Health Services.
 - iii. Risk Level 2 dischargers shall monitor and report run-on from surrounding areas if there is reason to believe run-on may contribute to an exceedance of NALs.

11. Risk Level 2 – Non-Visible Pollutant Monitoring Requirements

- a. Risk Level 2 dischargers shall collect one or more samples during any breach, malfunction, leakage, or spill observed during a visual inspection which could result in the discharge of pollutants to surface waters that would not be visually detectable in storm water.
- b. Risk Level 2 dischargers shall ensure that water samples are large enough to characterize the site conditions.
- c. Risk Level 2 dischargers shall collect samples at all discharge locations that can be safely accessed.
- d. Risk Level 2 dischargers shall collect samples during the first two hours of discharge from rain events that occur during business hours and which generate runoff.
- e. Risk Level 2 dischargers shall analyze samples for all non-visible pollutant parameters (if applicable) - parameters indicating the presence of pollutants identified in the pollutant source assessment required (Risk Level 2 dischargers shall modify their CSMPs to address these additional parameters in accordance with any updated SWPPP pollutant source assessment).
- f. Risk Level 2 dischargers shall collect a sample of storm water that has not come in contact with the disturbed soil or the materials stored or used on-site (uncontaminated sample) for comparison with the discharge sample.
- g. Risk Level 2 dischargers shall compare the uncontaminated sample to the samples of discharge using field analysis or through laboratory analysis.⁶
- h. Risk Level 2 dischargers shall keep all field /or analytical data in the SWPPP document.

12. Risk Level 2 – Watershed Monitoring Option

Risk Level 2 dischargers who are part of a qualified regional watershed-based monitoring program may be eligible for relief from the requirements in Sections I.5. The Regional Water Board may approve proposals to substitute an acceptable watershed-based monitoring program by determining if the watershed-based monitoring program

⁶ For laboratory analysis, all sampling, sample preservation, and analyses must be conducted according to test procedures under 40 CFR Part 136. Field discharge samples shall be collected and analyzed according to the specifications of the manufacturer of the sampling devices employed.

will provide substantially similar monitoring information in evaluating discharger compliance with the requirements of this General Permit.

13. Risk Level 2 – Particle Size Analysis for Project Risk Justification

Risk Level 2 dischargers justifying an alternative project risk shall report a soil particle size analysis used to determine the RUSLE K-Factor. ASTM D-422 (Standard Test Method for Particle-Size Analysis of Soils), as revised, shall be used to determine the percentages of sand, very fine sand, silt, and clay on the site.

14. Risk Level 2 – Records

Risk Level 2 dischargers shall retain records of all storm water monitoring information and copies of all reports (including Annual Reports) for a period of at least three years. Risk Level 2 dischargers shall retain all records on-site while construction is ongoing. These records include:

- a. The date, place, time of facility inspections, sampling, visual observation (inspections), and/or measurements, including precipitation.
- b. The individual(s) who performed the facility inspections, sampling, visual observation (inspections), and or measurements.
- c. The date and approximate time of analyses.
- d. The individual(s) who performed the analyses.
- e. A summary of all analytical results from the last three years, the method detection limits and reporting units, the analytical techniques or methods used, and the chain of custody forms.
- f. Rain gauge readings from site inspections;
- g. Quality assurance/quality control records and results.
- h. Non-storm water discharge inspections and visual observation (inspections) and storm water discharge visual observation records (see Sections I.3 and I.10 above).
- i. Visual observation and sample collection exception records (see Section I.6 above).

- j. The records of any corrective actions and follow-up activities that resulted from analytical results, visual observation (inspections), or inspections.

15. Risk Level 2 – NAL Exceedance Report

- a. In the event that any effluent sample exceeds an applicable NAL, Risk Level 2 dischargers shall electronically submit all storm event sampling results to the State Water Board no later than 10 days after the conclusion of the storm event. The Regional Boards have the authority to require the submittal of an NAL Exceedance Report.
- b. Risk Level 2 dischargers shall certify each NAL Exceedance Report in accordance with the Special Provisions for Construction Activity.
- c. Risk Level 2 dischargers shall retain an electronic or paper copy of each NAL Exceedance Report for a minimum of three years after the date the annual report is filed.
- d. Risk Level 2 dischargers shall include in the NAL Exceedance Report:
 - i. The analytical method(s), method reporting unit(s), and method detection limit(s) of each analytical parameter (analytical results that are less than the method detection limit shall be reported as “less than the method detection limit”).
 - ii. The date, place, time of sampling, visual observation (inspections), and/or measurements, including precipitation.
 - iii. A description of the current BMPs associated with the effluent sample that exceeded the NAL and the proposed corrective actions taken.

Table 3 – Risk Level 2 Test Methods, Detection Limits, Reporting Units and Applicable NALs/NELs

Parameter	Test Method / Protocol	Discharge Type	Min. Detection Limit	Reporting Units	Numeric Action Level
pH	Field test with calibrated portable instrument	Risk Level 2 Discharges	0.2 pH	units	lower NAL = 6.5 upper NAL = 8.5
Turbidity EPA	0180.1 and/or field test with calibrated portable instrument	Risk Level 2 Discharges other than ATS	1 NTU		250 NTU
		For ATS discharges	1 NTU		N/A

ATTACHMENT E RISK LEVEL 3 REQUIREMENTS

A. Effluent Standards

[These requirements are the same as those in the General Permit order.]

1. Narrative – Risk Level 3 dischargers shall comply with the narrative effluent standards listed below:
 - a. Storm water discharges and authorized non-storm water discharges regulated by this General Permit shall not contain a hazardous substance equal to or in excess of reportable quantities established in 40 C.F.R. §§ 117.3 and 302.4, unless a separate NPDES Permit has been issued to regulate those discharges.
 - b. Dischargers shall minimize or prevent pollutants in storm water discharges and authorized non-storm water discharges through the use of controls, structures, and management practices that achieve BAT for toxic and non-conventional pollutants and BCT for conventional pollutants.
2. Numeric –Risk Level 3 dischargers are subject to a pH NAL of 6.5-8.5, and a turbidity NAL of 250 NTU. In addition, Risk Level 3 dischargers are subject to a pH NEL of 6.0-9.0 and a turbidity NEL of 500 NTU.

B. Good Site Management "Housekeeping"

1. Risk Level 3 dischargers shall implement good site management (i.e., "housekeeping") measures for construction materials that could potentially be a threat to water quality if discharged. At a minimum, Risk Level 3 dischargers shall implement the following good housekeeping measures:
 - a. Conduct an inventory of the products used and/or expected to be used and the end products that are produced and/or expected to be produced. This does not include materials and equipment that are designed to be outdoors and exposed to environmental conditions (i.e. poles, equipment pads, cabinets, conductors, insulators, bricks, etc.).
 - b. Cover and berm loose stockpiled construction materials that are not actively being used (i.e. soil, spoils, aggregate, fly-ash, stucco, hydrated lime, etc.).

- c. Store chemicals in watertight containers (with appropriate secondary containment to prevent any spillage or leakage) or in a storage shed (completely enclosed).
 - d. Minimize exposure of construction materials to precipitation. This does not include materials and equipment that are designed to be outdoors and exposed to environmental conditions (i.e. poles, equipment pads, cabinets, conductors, insulators, bricks, etc.).
 - e. Implement BMPs to prevent the off-site tracking of loose construction and landscape materials.
2. Risk Level 3 dischargers shall implement good housekeeping measures for waste management, which, at a minimum, shall consist of the following:
- a. Prevent disposal of any rinse or wash waters or materials on impervious or pervious site surfaces or into the storm drain system.
 - b. Ensure the containment of sanitation facilities (e.g., portable toilets) to prevent discharges of pollutants to the storm water drainage system or receiving water.
 - c. Clean or replace sanitation facilities and inspecting them regularly for leaks and spills.
 - d. Cover waste disposal containers at the end of every business day and during a rain event.
 - e. Prevent discharges from waste disposal containers to the storm water drainage system or receiving water.
 - f. Contain and securely protecting stockpiled waste material from wind and rain at all times unless actively being used.
 - g. Implement procedures that effectively address hazardous and non-hazardous spills.
 - h. Develop a spill response and implementation element of the SWPPP prior to commencement of construction activities. The SWPPP shall require that:
 - i. Equipment and materials for cleanup of spills shall be available on site and that spills and leaks shall be cleaned up immediately and disposed of properly; and

- ii. Appropriate spill response personnel are assigned and trained.
 - i. Ensure the containment of concrete washout areas and other washout areas that may contain additional pollutants so there is no discharge into the underlying soil and onto the surrounding areas.
3. Risk Level 3 dischargers shall implement good housekeeping for vehicle storage and maintenance, which, at a minimum, shall consist of the following:
 - a. Prevent oil, grease, or fuel to leak in to the ground, storm drains or surface waters.
 - b. Place all equipment or vehicles, which are to be fueled, maintained and stored in a designated area fitted with appropriate BMPs.
 - c. Clean leaks immediately and disposing of leaked materials properly.
4. Risk Level 3 dischargers shall implement good housekeeping for landscape materials, which, at a minimum, shall consist of the following:
 - a. Contain stockpiled materials such as mulches and topsoil when they are not actively being used.
 - b. Contain fertilizers and other landscape materials when they are not actively being used.
 - c. Discontinuing the application of any erodible landscape material within 2 days before a forecasted rain event or during periods of precipitation.
 - d. Applying erodible landscape material at quantities and application rates according to manufacture recommendations or based on written specifications by knowledgeable and experienced field personnel.
 - e. Stacking erodible landscape material on pallets and covering or storing such materials when not being used or applied.
5. Risk Level 3 dischargers shall conduct an assessment and create a list of potential pollutant sources and identify any areas of the site where additional BMPs are necessary to reduce or prevent pollutants in storm water discharges and authorized non-storm water discharges. This potential pollutant list shall be kept with the SWPPP and shall identify

all non-visible pollutants which are known, or should be known, to occur on the construction site. At a minimum, when developing BMPs, Risk Level 3 dischargers shall do the following:

- a. Consider the quantity, physical characteristics (e.g., liquid, powder, solid), and locations of each potential pollutant source handled, produced, stored, recycled, or disposed of at the site.
 - b. Consider the degree to which pollutants associated with those materials may be exposed to and mobilized by contact with storm water.
 - c. Consider the direct and indirect pathways that pollutants may be exposed to storm water or authorized non-storm water discharges. This shall include an assessment of past spills or leaks, non-storm water discharges, and discharges from adjoining areas.
 - d. Ensure retention of sampling, visual observation, and inspection records.
 - e. Ensure effectiveness of existing BMPs to reduce or prevent pollutants in storm water discharges and authorized non-storm water discharges.
6. Risk Level 3 dischargers shall implement good housekeeping measures on the construction site to control the air deposition of site materials and from site operations. Such particulates can include, but are not limited to, sediment, nutrients, trash, metals, bacteria, oil and grease and organics.
7. **Additional Risk Level 3 Requirement:** Risk Level 3 dischargers shall document all housekeeping BMPs in the SWPPP and REAP(s) in accordance with the nature and phase of the construction project. Construction phases at traditional land development projects include Grading and Land Development Phase, Streets and Utilities, or Vertical Construction for traditional land development projects.

C. Non-Storm Water Management

1. Risk Level 3 dischargers shall implement measures to control all non-storm water discharges during construction.
2. Risk Level 3 dischargers shall wash vehicles in such a manner as to prevent non-storm water discharges to surface waters or MS4 drainage systems.

3. Risk Level 3 dischargers shall clean streets in such a manner as to prevent unauthorized non-storm water discharges from reaching surface water or MS4 drainage systems.

D. Erosion Control

1. Risk Level 3 dischargers shall implement effective wind erosion control.
2. Risk Level 3 dischargers shall provide effective soil cover for inactive¹ areas and all finished slopes, open space, utility backfill, and completed lots.
3. Dischargers shall limit the use of plastic materials when more sustainable, environmentally friendly alternatives exist. Where plastic materials are deemed necessary, the discharger shall consider the use of plastic materials resistant to solar degradation.

E. Sediment Controls

1. Risk Level 3 dischargers shall establish and maintain effective perimeter controls and stabilize all construction entrances and exits to sufficiently control erosion and sediment discharges from the site.
2. On sites where sediment basins are to be used, Risk Level 3 dischargers shall, at minimum, design sediment basins according to the method provided in CASQA's Construction BMP Guidance Handbook.
3. **Additional Risk Level 3 Requirement:** Risk Level 3 dischargers shall implement appropriate erosion control BMPs (runoff control and soil stabilization) in conjunction with sediment control BMPs for areas under active² construction.
4. **Additional Risk Level 3 Requirement:** Risk Level 3 dischargers shall apply linear sediment controls along the toe of the slope, face of the slope, and at the grade breaks of exposed slopes to comply with sheet flow lengths³ in accordance with Table 1.

¹ Inactive areas of construction are areas of construction activity that have been disturbed and are not scheduled to be re-disturbed for at least 14 days.

² Active areas of construction are areas undergoing land surface disturbance. This includes construction activity during the preliminary stage, mass grading stage, streets and utilities stage and the vertical construction stage

³ Sheet flow length is the length that shallow, low velocity flow travels across a site.

Table 1 - Critical Slope/Sheet Flow Length Combinations

Slope Percentage	Sheet flow length not to exceed
0-25% 20	feet
25-50% 15	feet
Over 50%	10 feet

5. **Additional Risk Level 3 Requirement:** Risk Level 3 dischargers shall ensure that construction activity traffic to and from the project is limited to entrances and exits that employ effective controls to prevent offsite tracking of sediment.
6. **Additional Risk Level 3 Requirement:** Risk Level 3 dischargers shall ensure that all storm drain inlets and perimeter controls, runoff control BMPs, and pollutant controls at entrances and exits (e.g. tire washoff locations) are maintained and protected from activities that reduce their effectiveness.
7. **Additional Risk Level 3 Requirement:** Risk Level 3 dischargers shall inspect on a daily basis all immediate access roads daily. At a minimum daily (when necessary) and prior to any rain event, the discharger shall remove any sediment or other construction activity-related materials that are deposited on the roads (by vacuuming or sweeping).
8. **Additional Risk Level 3 Requirement:** The Regional Water Board may require Risk Level 3 dischargers to implement additional site-specific sediment control requirements if the implementation of the other requirements in this section are not adequately protecting the receiving waters.

F. Run-on and Run-off Controls

Risk Level 3 dischargers shall effectively manage all run-on, all runoff within the site and all runoff that discharges off the site. Run-on from off site shall be directed away from all disturbed areas or shall collectively be in compliance with the effluent limitations in this General Permit.

G. Inspection, Maintenance and Repair

1. Risk Level 3 dischargers shall ensure that all inspection, maintenance repair and sampling activities at the project location shall be performed or supervised by a Qualified SWPPP Practitioner (QSP) representing the discharger. The QSP may delegate any or all of these activities to an employee appropriately trained to do the task(s).

2. Risk Level 3 dischargers shall perform weekly inspections and observations, and at least once each 24-hour period during extended storm events, to identify and record BMPs that need maintenance to operate effectively, that have failed, or that could fail to operate as intended. Inspectors shall be the QSP or be trained by the QSP.
3. Upon identifying failures or other shortcomings, as directed by the QSP, Risk Level 3 dischargers shall begin implementing repairs or design changes to BMPs within 72 hours of identification and complete the changes as soon as possible.
4. For each inspection required, Risk Level 3 dischargers shall complete an inspection checklist, using a form provided by the State Water Board or Regional Water Board or in an alternative format.
5. Risk Level 3 dischargers shall ensure that checklists shall remain onsite with the SWPPP and at a minimum, shall include:
 - a. Inspection date and date the inspection report was written.
 - b. Weather information, including presence or absence of precipitation, estimate of beginning of qualifying storm event, duration of event, time elapsed since last storm, and approximate amount of rainfall in inches.
 - c. Site information, including stage of construction, activities completed, and approximate area of the site exposed.
 - d. A description of any BMPs evaluated and any deficiencies noted.
 - e. If the construction site is safely accessible during inclement weather, list the observations of all BMPs: erosion controls, sediment controls, chemical and waste controls, and non-storm water controls. Otherwise, list the results of visual inspections at all relevant outfalls, discharge points, downstream locations and any projected maintenance activities.
 - f. Report the presence of noticeable odors or of any visible sheen on the surface of any discharges.
 - g. Any corrective actions required, including any necessary changes to the SWPPP and the associated implementation dates.
 - h. Photographs taken during the inspection, if any.

- i. Inspector's name, title, and signature.

H. Rain Event Action Plan

1. **Additional Risk Level 3 Requirement:** The discharger shall ensure a QSP develop a Rain Event Action Plan (REAP) 48 hours prior to any likely precipitation event. A likely precipitation event is any weather pattern that is forecast to have a 50% or greater probability of producing precipitation in the project area. The QSP shall obtain a printed copy of precipitation forecast information from the National Weather Service Forecast Office (e.g., by entering the zip code of the project's location at <http://www.srh.noaa.gov/forecast>).
2. **Additional Risk Level 3 Requirement:** The discharger shall ensure a QSP develop the REAPs for all phases of construction (i.e., Grading and Land Development, Streets and Utilities, Vertical Construction, Final Landscaping and Site Stabilization).
3. **Additional Risk Level 3 Requirement:** The discharger shall ensure a QSP ensure that the REAP include, at a minimum, the following site information:
 - a. Site Address.
 - b. Calculated Risk Level (2 or 3).
 - c. Site Storm Water Manager Information including the name, company, and 24-hour emergency telephone number.
 - d. Erosion and Sediment Control Provider information including the name, company, and 24-hour emergency telephone number.
 - e. Storm Water Sampling Agent information including the name, company, and 24-hour emergency telephone number.
4. **Additional Risk Level 3 Requirement:** The QSP shall include in the REAP, at a minimum, the following project phase information:
 - a. Activities associated with each construction phase.
 - b. Trades active on the construction site during each construction phase.
 - c. Trade contractor information.
 - d. Suggested actions for each project phase.
5. **Additional Risk Level 3 Requirement:** The QSP shall develop additional REAPs for project sites where construction activities are indefinitely halted or postponed (Inactive Construction). At a minimum, Inactive Construction REAPs must include:

- a. Site Address.
 - b. Calculated Risk Level (2 or 3).
 - c. Site Storm Water Manager Information including the name, company, and 24-hour emergency telephone number.
 - d. Erosion and Sediment Control Provider information including the name, company, and 24-hour emergency telephone number.
 - e. Storm Water Sampling Agent information including the name, company, and 24-hour emergency telephone number.
 - f. Trades active on site during Inactive Construction.
 - g. Trade contractor information.
 - h. Suggested actions for inactive construction sites.
6. **Additional Risk Level 3 Requirement:** The discharger shall ensure a QSP begin implementation and make the REAP available onsite no later than 24 hours prior to the likely precipitation event.
7. **Additional Risk Level 3 Requirement:** The discharger shall ensure a QSP maintain onsite a paper copy of each REAP onsite in compliance with the record retention requirements of the Special Provisions in this General Permit.

I. Risk Level 3 Monitoring and Reporting Requirements

Table 2- Summary of Monitoring Requirements

Risk Level	Visual Inspections					Sample Collection	
	Quarterly Non-storm Water Discharge	Pre-storm Event		Daily Storm BMP	Post Storm	Storm Water Discharge	Receiving Water
		Baseline	REAP				
3	X	X	X	X	X	X	X ⁴

1. Construction Site Monitoring Program Requirements

- a. Pursuant to Water Code Sections 13383 and 13267, all dischargers subject to this General Permit shall develop and implement a written site-specific Construction Site Monitoring Program (CSMP) in accordance with the requirements of this Section. The CSMP shall include all monitoring procedures and instructions, location maps, forms, and checklists as required in this section. The CSMP shall be developed prior to the commencement of construction activities, and revised as necessary to reflect project revisions. The CSMP shall be a part of the Storm Water Pollution Prevention Plan (SWPPP), included as an appendix or separate SWPPP chapter.
- b. Existing dischargers registered under the State Water Board Order No. 99-08-DWQ shall make and implement necessary revisions to their Monitoring Program to reflect the changes in this General Permit in a timely manner, but no later than July 1, 2010. Existing dischargers shall continue to implement their existing Monitoring Program in compliance with State Water Board Order No. 99-08-DWQ until the necessary revisions are completed according to the schedule above.
- c. When a change of ownership occurs for all or any portion of the construction site prior to completion or final stabilization, the new discharger shall comply with these requirements as of the date the ownership change occurs.

2. Objectives

The CSMP shall be developed and implemented to address the following objectives:

⁴ When NEL exceeded

- a. To demonstrate that the site is in compliance with the Discharge Prohibitions and applicable Numeric Action Levels (NALs)/Numeric Effluent Limitations (NELs) of this General Permit.
 - b. To determine whether non-visible pollutants are present at the construction site and are causing or contributing to exceedances of water quality objectives.
 - c. To determine whether immediate corrective actions, additional Best Management Practice (BMP) implementation, or SWPPP revisions are necessary to reduce pollutants in storm water discharges and authorized non-storm water discharges.
 - d. To determine whether BMPs included in the SWPPP/Rain Event Action Plan (REAP) are effective in preventing or reducing pollutants in storm water discharges and authorized non-storm water discharges.
- 3. Risk Level 3 – Visual Monitoring (Inspection) Requirements for Qualifying Rain Events**
- a. Risk Level 3 dischargers shall visually observe (inspect) storm water discharges at all discharge locations within two business days (48 hours) after each qualifying rain event.
 - b. Risk Level 3 dischargers shall visually observe (inspect) the discharge of stored or contained storm water that is derived from and discharged subsequent to a qualifying rain event producing precipitation of ½ inch or more at the time of discharge. Stored or contained storm water that will likely discharge after operating hours due to anticipated precipitation shall be observed prior to the discharge during operating hours.
 - c. Risk Level 3 dischargers shall conduct visual observations (inspections) during business hours only.
 - d. Risk Level 3 dischargers shall record the time, date and rain gauge reading of all qualifying rain events.
 - e. Within 2 business days (48 hours) prior to each qualifying rain event, Risk Level 3 dischargers shall visually observe (inspect):
 - i. all storm water drainage areas to identify any spills, leaks, or uncontrolled pollutant sources. If needed, the discharger shall implement appropriate corrective actions.

- ii. all BMPs to identify whether they have been properly implemented in accordance with the SWPPP/REAP. If needed, the discharger shall implement appropriate corrective actions.
 - iii. any storm water storage and containment areas to detect leaks and ensure maintenance of adequate freeboard.
- f. For the visual observations (inspections) described in c.i. and c.iii above, Risk Level 3 dischargers shall observe the presence or absence of floating and suspended materials, a sheen on the surface, discolorations, turbidity, odors, and source(s) of any observed pollutants.
 - g. Within two business days (48 hours) after each qualifying rain event, Risk Level 3 dischargers shall conduct post rain event visual observations (inspections) to (1) identify whether BMPs were adequately designed, implemented, and effective, and (2) identify additional BMPs and revise the SWPPP accordingly.
 - h. Risk Level 3 dischargers shall maintain on-site records of all visual observations (inspections), personnel performing the observations, observation dates, weather conditions, locations observed, and corrective actions taken in response to the observations.

4. Risk Level 3 – Water Quality Sampling and Analysis

- a. Risk Level 3 dischargers shall collect storm water grab samples from sampling locations, as defined in Section I.5. The storm water grab sample(s) obtained shall be representative of the flow and characteristics of the discharge.
- b. At minimum, Risk Level 3 dischargers shall collect 3 samples per day of the qualifying event.
- c. Risk Level 3 dischargers shall ensure that the grab samples collected of stored or contained storm water are from discharges subsequent to a qualifying rain event (producing precipitation of ½ inch or more at the time of discharge).

Storm Water Effluent Monitoring Requirements

- d. Risk Level 3 dischargers shall analyze their effluent samples for:
 - i. pH and turbidity.

- ii. Any additional parameters for which monitoring is required by the Regional Water Board.
- e. Risk 3 dischargers shall electronically submit all storm event sampling results to the State Water Board no later than 5 days after the conclusion of the storm event.
- f. Risk Level 3 discharger sites that have violated the turbidity daily average NEL shall analyze subsequent effluent samples for all the parameters specified in Section I.4.e, above, and Suspended Sediment Concentration (SSC).

Receiving Water Monitoring Requirements

- g. In the event that a Risk Level 3 discharger violates an NEL contained in this General Permit and has a direct discharge into receiving waters, the Risk Level 3 discharger shall subsequently sample receiving waters (RWs) for all parameter(s) required in Section I.4.e above for the duration of coverage under this General Permit.
- h. Risk Level 3 dischargers disturbing 30 acres or more of the landscape and with direct discharges into receiving waters shall conduct or participate in benthic macroinvertebrate bioassessment of RWs prior to commencement of construction activity (See Appendix 3).
- i. Risk Level 3 dischargers shall obtain RW samples in accordance with the Receiving Water sampling location section (Section I.5), below.

5. Risk Level 3 – Storm Water Discharge Water Quality Sampling Locations

Effluent Sampling Locations

- a. Risk Level 3 dischargers shall perform sampling and analysis of storm water discharges to characterize discharges associated with construction activity from the entire project disturbed area.
- b. Risk Level 3 dischargers shall collect effluent samples at all discharge points where storm water is discharged off-site.

- c. Risk Level 3 dischargers shall ensure that storm water discharge collected and observed represent⁵ the effluent in each drainage area based on visual observation of the water and upstream conditions.
- d. Risk Level 3 dischargers shall monitor and report site run-on from surrounding areas if there is reason to believe run-on may contribute to an exceedance of NALs or NELs.
- e. Risk Level 3 dischargers who deploy an ATS on their site, or a portion on their site, shall collect ATS effluent samples and measurements from the discharge pipe or another location representative of the nature of the discharge.
- f. Risk Level 3 dischargers shall select analytical test methods from the list provided in Table 3 below.
- g. All storm water sample collection preservation and handling shall be conducted in accordance with Section 1.7 "Storm Water Sample Collection and Handling Instructions" below.

Receiving Water Sampling Locations

- h. **Upstream/up-gradient RW samples:** Risk Level 3 dischargers shall obtain any required upstream/up-gradient receiving water samples from a representative and accessible location as close as possible and upstream from the effluent discharge point.
- i. **Downstream/down-gradient RW samples:** Risk Level 3 dischargers shall obtain any required downstream/down-gradient receiving water samples from a representative and accessible location as close as possible and downstream from the effluent discharge point.
- j. If two or more discharge locations discharge to the same receiving water, Risk Level 3 dischargers may sample the receiving water at a single upstream and downstream location.

⁵ For example, if there has been concrete work recently in an area, or drywall scrap is exposed to the rain, a pH sample shall be taken of drainage from the relevant work area. Similarly, if sediment-laden water is flowing through some parts of a silt fence, samples shall be taken of the sediment laden water even if most water flowing through the fence is clear.

6. Risk Level 3 – Visual Observation and Sample Collection Exemptions

- a. Risk Level 3 dischargers shall be prepared to collect samples and conduct visual observation (inspections) until the minimum requirements of Sections I.3 and I.4 above are completed. Risk Level 3 dischargers are not required to physically collect samples or conduct visual observation (inspections) under the following conditions:
 - i. During dangerous weather conditions such as flooding and electrical storms.
 - ii. Outside of scheduled site business hours.
- b. If no required samples or visual observation (inspections) are collected due to these exceptions, Risk Level 3 dischargers shall include an explanation in their SWPPP and in the Annual Report documenting why the sampling or visual observation (inspections) were not conducted.

7. Risk Level 3 – Storm Water Sample Collection and Handling Instructions

- a. Risk Level 3 dischargers shall refer to Table 3 below for test methods, detection limits, and reporting units.
- b. Risk Level 3 dischargers shall ensure that testing laboratories will receive samples within 48 hours of the physical sampling (unless otherwise required by the laboratory), and shall use only the sample containers provided by the laboratory to collect and store samples.
- c. Risk Level 3 dischargers shall designate and train personnel to collect, maintain, and ship samples in accordance with the Surface Water Ambient Monitoring Program's (SWAMP) 2008 Quality Assurance Program Plan (QAPrP).⁶

⁶ Additional information regarding SWAMP's QAPrP and QAMP can be found at http://www.waterboards.ca.gov/water_issues/programs/swamp/.
QAPrP: http://www.waterboards.ca.gov/water_issues/programs/swamp/docs/qapp/swamp_qapp_master090108a.pdf
QAMP: http://www.waterboards.ca.gov/water_issues/programs/swamp/qamp.shtml

8. Risk Level 3 – Monitoring Methods

- a. Risk Level 3 dischargers shall include a description of the following items in the CSMP:
 - i. Visual observation locations, visual observation procedures, and visual observation follow-up and tracking procedures.
 - ii. Sampling locations, and sample collection and handling procedures. This shall include detailed procedures for sample collection, storage, preservation, and shipping to the testing lab to assure that consistent quality control and quality assurance is maintained. Dischargers shall attach to the monitoring program an example Chain of Custody form used when handling and shipping samples.
 - iii. Identification of the analytical methods and related method detection limits (if applicable) for each parameter required in Section I.4 above.
- b. Risk Level 3 dischargers shall ensure that all sampling and sample preservation are in accordance with the current edition of "Standard Methods for the Examination of Water and Wastewater" (American Public Health Association). All monitoring instruments and equipment (including a discharger's own field instruments for measuring pH and turbidity) should be calibrated and maintained in accordance with manufacturers' specifications to ensure accurate measurements. Risk Level 3 dischargers shall ensure that all laboratory analyses are conducted according to test procedures under 40 CFR Part 136, unless other test procedures have been specified in this General Permit or by the Regional Water Board. With the exception of field analysis conducted by the discharger for turbidity and pH, all analyses should be sent to and conducted at a laboratory certified for such analyses by the State Department of Health Services (SSC exception). Risk Level 3 dischargers shall conduct their own field analysis of pH and may conduct their own field analysis of turbidity if the discharger has sufficient capability (qualified and trained employees, properly calibrated and maintained field instruments, etc.) to adequately perform the field analysis.

9. Risk Level 3 – Analytical Methods

- a. Risk Level 3 dischargers shall refer to Table 3 below for test methods, detection limits, and reporting units.

- b. **pH:** Risk Level 3 dischargers shall perform pH analysis on-site with a calibrated pH meter or a pH test kit. Risk Level 3 dischargers shall record pH monitoring results on paper and retain these records in accordance with Section I.14, below.
- c. **Turbidity:** Risk Level 3 dischargers shall perform turbidity analysis using a calibrated turbidity meter (turbidimeter), either on-site or at an accredited lab. Acceptable test methods include Standard Method 2130 or USEPA Method 180.1. The results will be recorded in the site log book in Nephelometric Turbidity Units (NTU).
- d. **Suspended sediment concentration (SSC):** Risk Level 3 dischargers shall perform SSC analysis using ASTM Method D3977-97.
- e. **Bioassessment:** Risk Level 3 dischargers shall perform bioassessment sampling and analysis according to Appendix 3 of this General Permit.

10. Risk Level 3 - Non-Storm Water Discharge Monitoring Requirements

- a. Visual Monitoring Requirements:
 - i. Risk Level 3 dischargers shall visually observe (inspect) each drainage area for the presence of (or indications of prior) unauthorized and authorized non-storm water discharges and their sources.
 - ii. Risk Level 3 dischargers shall conduct one visual observation (inspection) quarterly in each of the following periods: January-March, April-June, July-September, and October-December. Visual observation (inspections) are only required during daylight hours (sunrise to sunset).
 - iii. Risk Level 3 dischargers shall ensure that visual observations (inspections) document the presence or evidence of any non-storm water discharge (authorized or unauthorized), pollutant characteristics (floating and suspended material, sheen, discoloration, turbidity, odor, etc.), and source. Risk Level 3 dischargers shall maintain on-site records indicating the personnel performing the visual observation (inspections), the dates and approximate time each drainage area and non-storm water discharge was observed, and the response taken to eliminate unauthorized non-storm water discharges and to

reduce or prevent pollutants from contacting non-storm water discharges.

- b. Effluent Sampling Locations:
 - i. Risk Level 3 dischargers shall sample effluent at all discharge points where non-storm water and/or authorized non-storm water is discharged off-site.
 - ii. Risk Level 3 dischargers shall send all non-storm water sample analyses to a laboratory certified for such analyses by the State Department of Health Services.
 - iii. Risk Level 3 dischargers shall monitor and report run-on from surrounding areas if there is reason to believe run-on may contribute to an exceedance of NALs or NELs.

11. Risk Level 3 – Non-Visible Pollutant Monitoring Requirements

- a. Risk Level 3 dischargers shall collect one or more samples during any breach, malfunction, leakage, or spill observed during a visual inspection which could result in the discharge of pollutants to surface waters that would not be visually detectable in storm water.
- b. Risk Level 3 dischargers shall ensure that water samples are large enough to characterize the site conditions.
- c. Risk Level 3 dischargers shall collect samples at all discharge locations that can be safely accessed.
- d. Risk Level 3 dischargers shall collect samples during the first two hours of discharge from rain events that occur during business hours and which generate runoff.
- e. Risk Level 3 dischargers shall analyze samples for all non-visible pollutant parameters (if applicable) - parameters indicating the presence of pollutants identified in the pollutant source assessment required (Risk Level 3 dischargers shall modify their CSMPs to address these additional parameters in accordance with any updated SWPPP pollutant source assessment).
- f. Risk Level 3 dischargers shall collect a sample of storm water that has not come in contact with the disturbed soil or the materials stored or used on-site (uncontaminated sample) for comparison with the discharge sample.

- g. Risk Level 3 dischargers shall compare the uncontaminated sample to the samples of discharge using field analysis or through laboratory analysis.⁷
- h. Risk Level 3 dischargers shall keep all field /or analytical data in the SWPPP document.

12. Risk Level 3 – Watershed Monitoring Option

Risk Level 3 dischargers who are part of a qualified regional watershed-based monitoring program may be eligible for relief from the requirements in Sections I.5. The Regional Water Board may approve proposals to substitute an acceptable watershed-based monitoring program by determining if the watershed-based monitoring program will provide substantially similar monitoring information in evaluating discharger compliance with the requirements of this General Permit.

13. Risk Level 3 – Particle Size Analysis for Project Risk Justification

Risk Level 3 dischargers justifying an alternative project risk shall report a soil particle size analysis used to determine the RUSLE K-Factor. ASTM D-422 (Standard Test Method for Particle-Size Analysis of Soils), as revised, shall be used to determine the percentages of sand, very fine sand, silt, and clay on the site.

14. Risk Level 3 – Records

Risk Level 3 dischargers shall retain records of all storm water monitoring information and copies of all reports (including Annual Reports) for a period of at least three years. Risk Level 3 dischargers shall retain all records on-site while construction is ongoing. These records include:

- a. The date, place, time of facility inspections, sampling, visual observation (inspections), and/or measurements, including precipitation.
- b. The individual(s) who performed the facility inspections, sampling, visual observation (inspections), and or measurements.
- c. The date and approximate time of analyses.

⁷ For laboratory analysis, all sampling, sample preservation, and analyses must be conducted according to test procedures under 40 CFR Part 136. Field discharge samples shall be collected and analyzed according to the specifications of the manufacturer of the sampling devices employed.

- d. The individual(s) who performed the analyses.
- e. A summary of all analytical results from the last three years, the method detection limits and reporting units, the analytical techniques or methods used, and the chain of custody forms.
- f. Rain gauge readings from site inspections.
- g. Quality assurance/quality control records and results.
- h. Non-storm water discharge inspections and visual observation (inspections) and storm water discharge visual observation records (see Sections I.3 and I.10 above).
- i. Visual observation and sample collection exception records (see Section I.6 above).
- j. The records of any corrective actions and follow-up activities that resulted from analytical results, visual observation (inspections), or inspections.

15. Risk Level 3 – NAL Exceedance Report

- a. In the event that any effluent sample exceeds an applicable NAL, Risk Level 3 dischargers shall electronically submit all storm event sampling results to the State Water Board no later than 10 days after the conclusion of the storm event. The Regional Boards have the authority to require the submittal of an NAL Exceedance Report.
- b. Risk Level 3 dischargers shall certify each NAL Exceedance Report in accordance with the Special Provisions for Construction Activity In this General Permit.
- c. Risk Level 3 dischargers shall retain an electronic or paper copy of each NAL Exceedance Report for a minimum of three years after the date the annual report is filed.
- d. Risk Level 3 dischargers shall include in the NAL Exceedance Report:
 - i. The analytical method(s), method reporting unit(s), and method detection limit(s) of each analytical parameter (analytical results that are less than the method detection limit shall be reported as “less than the method detection limit”).

- ii. The date, place, time of sampling, visual observation (inspections), and/or measurements, including precipitation.
- iii. A description of the current BMPs associated with the effluent sample that exceeded the NAL and the proposed corrective actions taken.

16. Risk Level 3 – NEL Violation Report

- a. Risk Level 3 dischargers shall electronically submit all storm event sampling results to the State Water Board no later than 5 days after the conclusion of the storm event.
- b. In the event that a discharger has violated an applicable NEL, Risk Level 3 dischargers shall submit an NEL Violation Report to the State Water Board within 24 hours after the NEL exceedance has been identified.
- c. Risk Level 3 dischargers shall certify each NEL Violation Report in accordance with the Special Provisions for Construction Activity in this General Permit.
- d. Risk Level 3 dischargers shall retain an electronic or paper copy of each NEL Violation Report for a minimum of three years after the date the annual report is filed.
- e. Risk Level 3 dischargers shall include in the NEL Violation Report:
 - i. The analytical method(s), method reporting unit(s), and method detection limit(s) of each analytical parameter (analytical results that are less than the method detection limit shall be reported as “less than the method detection limit”);
 - ii. The date, place, time of sampling, visual observation (inspections), and/or measurements, including precipitation; and
 - iii. A Description of the current onsite BMPs, and the proposed corrective actions taken to manage the NEL exceedance.
- f. Compliance Storm Exemption - In the event that an applicable NEL has been exceeded during a storm event equal to or larger than the Compliance Storm Event, Risk level 3 discharger shall report the on-site rain gauge reading and nearby governmental rain gauge readings for verification.

17. Risk Level 3 – Bioassessment

- a. Risk Level 3 dischargers with a total project-related ground disturbance exceeding 30 acres shall:
 - i. Conduct bioassessment monitoring, as described in Appendix 3.
 - ii. Include the collection and reporting of specified in stream biological data and physical habitat.
 - iii. Use the bioassessment sample collection and Quality Assurance & Quality Control (QA/QC) protocols developed by the State of California's Surface Water Ambient Monitoring Program (SWAMP).⁸
- b. Risk Level 3 dischargers qualifying for bioassessment, where construction commences out of an index period for the site location shall:
 - i. Receive Regional Board approval for the sampling exception.
 - ii. Conduct bioassessment monitoring, as described in Appendix 3.
 - iii. Include the collection and reporting of specified instream biological data and physical habitat.
 - iv. Use the bioassessment sample collection and Quality Assurance & Quality Control (QA/QC) protocols developed by the State of California's Surface Water Ambient Monitoring Program (SWAMP).

OR

- v. Make a check payable to: Cal State Chico Foundation (SWAMP Bank Account) or San Jose State Foundation (SWAMP Bank Account) and include the WDID# on the check for the amount calculated for the exempted project.
- vi. Send a copy of the check to the Regional Water Board office for the site's region.
- vii. Invest **\$7,500.00 X The number of samples required** into the SWAMP program as compensation (upon regional board approval).

⁸ http://www.waterboards.ca.gov/water_issues/programs/swamp/.

Table 3 – Risk Level 3 Test Methods, Detection Limits, Reporting Units and Applicable NALs/NELs

Parameter	Test Method / Protocol	Discharge Type	Min. Detection Limit	Reporting Units	Numeric Action Level	Numeric Effluent Limitation
pH	Field test with calibrated portable instrument	Risk Level 3 Discharges	0.2 pH	units	lower NAL = 6.5 upper NAL = 8.5	lower NEL = 6.0 upper NEL = 9.0
Turbidity EPA	0180.1 and/or field test with calibrated portable instrument	Risk Level 3 Discharges other than ATS	1	NTU	250 NTU	500 NTU
		For ATS discharges	1 NTU		N/A	10 NTU for Daily Weighted Average & 20 NTU for Any Single Sample
SSC ASTM	Method D 3977-97 ⁹	Risk Level 3 (if NEL exceeded)	5 mg/L		N/A	N/A
Bioassessment	(STE) Level I of (SAFIT), ¹⁰ fixed-count of 600 org/sample	Risk Level 3 projects > 30 acres	N/A N/A		N/A	N/A

⁹ ASTM, 1999, Standard Test Method for Determining Sediment Concentration in Water Samples: American Society of Testing and Materials, D 3977-97, Vol. 11.02, pp. 389-394.

¹⁰ The current SAFIT STEs (28 November 2006) list requirements for both the Level I and Level II taxonomic effort, and are located at: http://www.swrcb.ca.gov/swamp/docs/safit/ste_list.pdf. When new editions are published by SAFIT, they will supersede all previous editions. All editions will be posted at the State Water Board's SWAMP website.

ATTACHMENT F: Active Treatment System (ATS) Requirements

Table 1 – Numeric Effluent Limitations, Numeric Action Levels, Test Methods, Detection Limits, and Reporting Units

Parameter	Test Method	Discharge Type	Min. Detection Limit	Units	Numeric Action Level	Numeric Effluent Limitation
Turbidity	EPA 0180.1 and/or field test with a calibrated portable instrument	For ATS discharges	1 NTU		N/A	10 NTU for Daily Flow-Weighted Average & 20 NTU for Any Single Sample

A. Dischargers choosing to implement an Active Treatment System (ATS) on their site shall comply with all of the requirements in this Attachment.

B. The discharger shall maintain a paper copy of each ATS specification onsite in compliance with the record retention requirements in the Special Provisions of this General Permit.

C. ATS Design, Operation and Submittals

1. The ATS shall be designed and approved by a Certified Professional in Erosion and Sediment Control (CPESC), a Certified Professional in Storm Water Quality (CPSWQ); a California registered civil engineer; or any other California registered engineer.
2. The discharger shall ensure that the ATS is designed in a manner to preclude the accidental discharge of settled floc¹ during floc pumping or related operations.
3. The discharger shall design outlets to dissipate energy from concentrated flows.
4. The discharger shall install and operate an ATS by assigning a lead person (or project manager) who has either a minimum of five years construction storm

¹ Floc is defined as a clump of solids formed by the chemical action in ATS systems.

water experience or who is a licensed contractors specifically holding a California Class A Contractors license.²

5. The discharger shall prepare an ATS Plan that combines the site-specific data and treatment system information required to safely and efficiently operate an ATS. The ATS Plan shall be electronically submitted to the State Water Board at least 14 days prior to the planned operation of the ATS and a paper copy shall be available onsite during ATS operation. At a minimum, the ATS Plan shall include:
 - a. ATS Operation and Maintenance Manual for All Equipment.
 - b. ATS Monitoring, Sampling & Reporting Plan, including Quality Assurance/Quality Control (QA/QC).
 - c. ATS Health and Safety Plan.
 - d. ATS Spill Prevention Plan.
6. The ATS shall be designed to capture and treat (within a 72-hour period) a volume equivalent to the runoff from a 10-year, 24-hour storm event using a watershed runoff coefficient of 1.0.

D. Treatment – Chemical Coagulation/Flocculation

1. Jar tests shall be conducted using water samples selected to represent typical site conditions and in accordance with ASTM D2035-08 (2003).
2. The discharger shall conduct, at minimum, six site-specific jar tests (per polymer with one test serving as a control) for each project to determine the proper polymer and dosage levels for their ATS.
3. Single field jar tests may also be conducted during a project if conditions warrant, for example if construction activities disturb changing types of soils, which consequently cause change in storm water and runoff characteristics.

E. Residual Chemical and Toxicity Requirements

1. The discharger shall utilize a residual chemical test method that has a method detection limit (MDL) of 10% or less than the maximum allowable threshold

² Business and Professions Code Division 3, Chapter 9, Article 4, Class A Contractor: A general engineering contractor is a contractor whose principal contracting business is in connection with fixed works requiring specialized engineering knowledge and skill. [<http://www.cslb.ca.gov/General-Information/library/licensing-classifications.asp>].

concentration³ (MATC) for the specific coagulant in use and for the most sensitive species of the chemical used.

2. The discharger shall utilize a residual chemical test method that produces a result within one hour of sampling.
3. The discharger shall have a California State certified laboratory validate the selected residual chemical test. Specifically the lab will review the test protocol, test parameters, and the detection limit of the coagulant. The discharger shall electronically submit this documentation as part of the ATS Plan.
4. If the discharger cannot utilize a residual chemical test method that meets the requirements above, the discharger shall operate the ATS in Batch Treatment⁴ mode.
5. A discharger planning to operate in Batch Treatment mode shall perform toxicity testing in accordance with the following:
 - a. The discharger shall initiate acute toxicity testing on effluent samples representing effluent from each batch prior to discharge⁵. All bioassays shall be sent to a laboratory certified by the Department of Health Services (DHS) Environmental Laboratory Accreditation Program (ELAP). The required field of testing number for Whole Effluent Toxicity (WET) testing is E113.⁶
 - b. Acute toxicity tests shall be conducted with the following species and protocols. The methods to be used in the acute toxicity testing shall be those outlined for a 96-hour acute test in "Methods for Measuring the Acute Toxicity of Effluents and Receiving Water to Freshwater and Marine Organisms, USEPA-841-R-02-012" for Fathead minnow, *Pimephales promelas* (fathead minnow). Acute toxicity for *Oncorhynchus mykiss* (Rainbow Trout) may be used as a substitute for testing fathead minnows.
 - c. All toxicity tests shall meet quality assurance criteria and test acceptability criteria in the most recent versions of the EPA test method for WET testing.
 - d. The discharger shall electronically report all acute toxicity testing.

³ The Maximum Allowable Threshold Concentration (MATC) is the allowable concentration of residual, or dissolved, coagulant/flocculant in effluent. The MATC shall be coagulant/flocculant-specific, and based on toxicity testing conducted by an independent, third-party laboratory. A typical MATC would be:

The MATC is equal to the geometric mean of the NOEC (No Observed Effect Concentration) and LOEC (Lowest Observed Effect Concentration) Acute and Chronic toxicity results for most sensitive species determined for the specific coagulant. The most sensitive species test shall be used to determine the MATC.

⁴ Batch Treatment mode is defined as holding or recirculating the treated water in a holding basin or tank(s) until treatment is complete or the basin or storage tank(s) is full.

⁵ This requirement only requires that the test be initiated prior to discharge.

⁶ http://www.dhs.ca.gov/ps/ls/elap/pdf/FOT_Desc.pdf.

F. Filtration

1. The ATS shall include a filtration step between the coagulant treatment train and the effluent discharge. This is commonly provided by sand, bag, or cartridge filters, which are sized to capture suspended material that might pass through the clarifier tanks.
2. Differential pressure measurements shall be taken to monitor filter loading and confirm that the final filter stage is functioning properly.

G. Residuals Management

1. Sediment shall be removed from the storage or treatment cells as necessary to ensure that the cells maintain their required water storage (i.e., volume) capability.
2. Handling and disposal of all solids generated during ATS operations shall be done in accordance with all local, state, and federal laws and regulations.

H. ATS Instrumentation

1. The ATS shall be equipped with instrumentation that automatically measures and records effluent water quality data and flow rate.
2. The minimum data recorded shall be consistent with the Monitoring and Reporting requirements below, and shall include:
 - a. Influent Turbidity
 - b. Effluent Turbidity
 - c. Influent pH
 - d. Effluent pH
 - e. Residual Chemical
 - f. Effluent Flow rate
 - g. Effluent Flow volume
3. Systems shall be equipped with a data recording system, such as data loggers or webserver-based systems, which records each measurement on a frequency no longer than once every 15 minutes.

4. Cumulative flow volume shall be recorded daily. The data recording system shall have the capacity to record a minimum of seven days continuous data.
5. Instrumentation systems shall be interfaced with system control to provide auto shutoff or recirculation in the event that effluent measurements exceed turbidity or pH.
6. The system shall also assure that upon system upset, power failure, or other catastrophic event, the ATS will default to a recirculation mode or safe shut down.
7. Instrumentation (flow meters, probes, valves, streaming current detectors, controlling computers, etc.) shall be installed and maintained per manufacturer's recommendations, which shall be included in the QA/QC plan.
8. The QA/QC plan shall also specify calibration procedures and frequencies, instrument method detection limit or sensitivity verification, laboratory duplicate procedures, and other pertinent procedures.
9. The instrumentation system shall include a method for controlling coagulant dose, to prevent potential overdosing. Available technologies include flow/turbidity proportional metering, periodic jar testing and metering pump adjustment, and ionic charge measurement controlling the metering pump.

I. ATS Effluent Discharge

1. ATS effluent shall comply with all provisions and prohibitions in this General Permit, specifically the NELs.
2. NELs for discharges from an ATS:
 - a. Turbidity of all ATS discharges shall be less than 10 NTU for daily flow-weighted average of all samples and 20 NTU for any single sample.
 - b. Residual Chemical shall be < 10% of MATC⁷ for the most sensitive species of the chemical used.
3. If an analytical effluent sampling result is outside the range of pH NELs (i.e., is below the lower NEL for pH or exceeds the upper NEL for pH) or exceeds the turbidity NEL (as listed in Table 1), the discharger is in violation of this General

⁷ The Maximum Allowable Threshold Concentration (MATC) is the allowable concentration of residual, or dissolved, coagulant/flocculant in effluent. The MATC shall be coagulant/flocculant-specific, and based on toxicity testing conducted by an independent, third-party laboratory. The MATC is equal to the geometric mean of the NOEC (No Observed Effect Concentration) and LOEC (Lowest Observed Effect Concentration) Acute and Chronic toxicity results for most sensitive species determined for the specific coagulant. The most sensitive species test shall be used to determine the MATC.

Permit and shall electronically file the results in violation within 24-hours of obtaining the results.

4. If ATS effluent is authorized to discharge into a sanitary sewer system, the discharger shall comply with any pre-treatment requirements applicable for that system. The discharger shall include any specific criteria required by the municipality in the ATS Plan.

5. Compliance Storm Event:

Discharges of storm water from ATS shall comply with applicable NELs (above) unless the storm event causing the discharges is determined after the fact to be equal to or larger than the Compliance Storm Event (expressed in inches of rainfall). The Compliance Storm Event for ATS discharges is the 10 year, 24 hour storm, as determined using these maps:

<http://www.wrcc.dri.edu/pcpnfreq/nca10y24.gif>
<http://www.wrcc.dri.edu/pcpnfreq/sca10y24.gif>

This exemption is dependent on the submission of rain gauge data verifying the storm event is equal to or larger than the Compliance Storm.

J. Operation and Maintenance Plan

1. Each Project shall have a site-specific Operation and Maintenance (O&M) Manual covering the procedures required to install, operate and maintain the ATS.⁸
2. The O&M Manual shall only be used in conjunction with appropriate project-specific design specifications that describe the system configuration and operating parameters.
3. The O&M Manual shall have operating manuals for specific pumps, generators, control systems, and other equipment.

K. Sampling and Reporting Quality Assurance/ Quality Check (QA/QC) Plan

4. A project-specific QA/QC Plan shall be developed for each project. The QA/QC Plan shall include at a minimum:
 - a. Calibration – Calibration methods and frequencies for all system and field instruments shall be specified.
 - b. Method Detection Limits (MDLs) – The methods for determining MDLs shall be specified for each residual coagulant measurement method. Acceptable

⁸ The manual is typically in a modular format covering generalized procedures for each component that is utilized in a particular system.

minimum MDLs for each method, specific to individual coagulants, shall be specified.

- c. Laboratory Duplicates – Requirements for monthly laboratory duplicates for residual coagulant analysis shall be specified.

L. Personnel Training

1. Operators shall have training specific to using an ATS and liquid coagulants for storm water discharges in California.
2. The training shall be in the form of a formal class with a certificate and requirements for testing and certificate renewal.
3. Training shall include a minimum of eight hours classroom and 32 hours field training. The course shall cover the following topics:
 - a. Coagulation Basics –Chemistry and physical processes
 - b. ATS System Design and Operating Principles
 - c. ATS Control Systems
 - d. Coagulant Selection – Jar testing, dose determination, etc.
 - e. Aquatic Safety/Toxicity of Coagulants, proper handling and safety
 - f. Monitoring, Sampling, and Analysis
 - g. Reporting and Recordkeeping
 - h. Emergency Response

M. Active Treatment System (ATS) Monitoring Requirements

Any discharger who deploys an ATS on their site shall conduct the following:

1. Visual Monitoring
 - a. A designated responsible person shall be on site daily at all times during treatment operations.
 - b. Daily on-site visual monitoring of the system for proper performance shall be conducted and recorded in the project data log.

- i. The log shall include the name and phone number of the person responsible for system operation and monitoring.
 - ii. The log shall include documentation of the responsible person's training.
2. Operational and Compliance Monitoring
- a. Flow shall be continuously monitored and recorded at not greater than 15-minute intervals for total volume treated and discharged.
 - b. Influent and effluent pH must be continuously monitored and recorded at not greater than 15-minute intervals.
 - c. Influent and effluent turbidity (expressed in NTU) must be continuously monitored and recorded at not greater than 15-minute intervals.
 - d. The type and amount of chemical used for pH adjustment, if any, shall be monitored and recorded.
 - e. Dose rate of chemical used in the ATS system (expressed in mg/L) shall be monitored and reported 15-minutes after startup and every 8 hours of operation.
 - f. Laboratory duplicates – monthly laboratory duplicates for residual coagulant analysis must be performed and records shall be maintained onsite.
 - g. Effluent shall be monitored and recorded for residual chemical/additive levels.
 - h. If a residual chemical/additive test does not exist and the ATS is operating in a batch treatment mode of operation refer to the toxicity monitoring requirements below.
3. Toxicity Monitoring

A discharger operating in batch treatment mode shall perform toxicity testing in accordance with the following:

- a. The discharger shall initiate acute toxicity testing on effluent samples representing effluent from each batch prior to discharge.⁹ All bioassays shall be sent to a laboratory certified by the Department of Health Services (DHS) Environmental Laboratory Accreditation Program (ELAP). The required field of testing number for Whole Effluent Toxicity (WET) testing is E113.¹⁰

⁹ This requirement only requires that the test be initiated prior to discharge.

¹⁰ http://www.dhs.ca.gov/ps/ls/elap/pdf/FOT_Desc.pdf.

- b. Acute toxicity tests shall be conducted with the following species and protocols. The methods to be used in the acute toxicity testing shall be those outlined for a 96-hour acute test in “Methods for Measuring the Acute Toxicity of Effluents and Receiving Water to Freshwater and Marine Organisms, USEPA-841-R-02-012” for Fathead minnow, *Pimephales promelas* or Rainbow trout *Oncorhynchus mykiss* may be used as a substitute for fathead minnow.
- c. All toxicity tests shall meet quality assurance criteria and test acceptability criteria in the most recent versions of the EPA test method for WET testing.¹¹

4. Reporting and Recordkeeping

At a minimum, every 30 days a LRP representing the discharger shall access the State Water Boards Storm Water Multi-Application and Report Tracking system (SMARTS) and electronically upload field data from the ATS. Records must be kept for three years after the project is completed .

5. Non-compliance Reporting

- a. Any indications of toxicity or other violations of water quality objectives shall be reported to the appropriate regulatory agency as required by this General Permit.
- b. Upon any measurements that exceed water quality standards, the system operator shall immediately notify his supervisor or other responsible parties, who shall notify the Regional Water Board.
- c. If any monitoring data exceeds any applicable NEL in this General Permit, the discharger shall electronically submit a NEL Violation Report to the State Water Board within 24 hours after the NEL exceedance has been identified.
 - i. ATS dischargers shall certify each NEL Violation Report in accordance with the Special Provisions for Construction Activity in this General Permit.
 - ii. ATS dischargers shall retain an electronic or paper copy of each NEL Violation Report for a minimum of three years after the date the annual report is filed.
 - iii. ATS dischargers shall include in the NEL Violation Report:
 - (1) The analytical method(s), method reporting unit(s), and method detection limit(s) of each analytical parameter (analytical results that are less than the method detection limit shall be reported as “less than the method detection limit”);

¹¹ <http://www.epa.gov/waterscience/methods/wet/>.

- (2) The date, place, time of sampling, visual observation (inspections), and/or measurements, including precipitation; and
 - (3) A description of the current onsite BMPs, and the proposed corrective actions taken to manage the NEL exceedance.
- iv. Compliance Storm Exemption - In the event that an applicable NEL has been exceeded during a storm event equal to or larger than the Compliance Storm Event, ATS dischargers shall report the on-site rain gauge reading and nearby governmental rain gauge readings for verification.

Risk Determination Worksheet

Step

- 1** Determine Sediment Risk via one of the options listed:
- [1. GIS Map Method - EPA Rainfall Erosivity Calculator & GIS map](#)
 - [2. Individual Method - EPA Rainfall Erosivity Calculator & Individual Data](#)

- Step**
2 Determine Receiving Water Risk via one of the options listed:

- [1. GIS map of Sediment Sensitive Watersheds provided \(in development\)](#)
- [2. List of Sediment Sensitive Watersheds provided](#)

Step

- 3** [Determine Combined Risk Level](#)

Sediment Risk Factor Worksheet		Entry
A) R Factor		
<p>Analyses of data indicated that when factors other than rainfall are held constant, soil loss is directly proportional to a rainfall factor composed of total storm kinetic energy (E) times the maximum 30-min intensity (I30) (Wischmeier and Smith, 1958). The numerical value of R is the average annual sum of EI30 for storm events during a rainfall record of at least 22 years. "Isoerodent" maps were developed based on R values calculated for more than 1000 locations in the Western U.S. Refer to the link below to determine the R factor for the project site.</p> <p>http://cfpub.epa.gov/npdes/stormwater/LEW/lewCalculator.cfm</p>		
R Factor Value		0
B) K Factor (weighted average, by area, for all site soils)		
<p>The soil-erodibility factor K represents: (1) susceptibility of soil or surface material to erosion, (2) transportability of the sediment, and (3) the amount and rate of runoff given a particular rainfall input, as measured under a standard condition. Fine-textured soils that are high in clay have low K values (about 0.05 to 0.15) because the particles are resistant to detachment. Coarse-textured soils, such as sandy soils, also have low K values (about 0.05 to 0.2) because of high infiltration resulting in low runoff even though these particles are easily detached. Medium-textured soils, such as a silt loam, have moderate K values (about 0.25 to 0.45) because they are moderately susceptible to particle detachment and they produce runoff at moderate rates. Soils having a high silt content are especially susceptible to erosion and have high K values, which can exceed 0.45 and can be as large as 0.65. Silt-size particles are easily detached and tend to crust, producing high rates and large volumes of runoff. Use Site-specific data must be submitted.</p> <p>Site-specific K factor guidance</p>		
K Factor Value		0
C) LS Factor (weighted average, by area, for all slopes)		
<p>The effect of topography on erosion is accounted for by the LS factor, which combines the effects of a hillslope-length factor, L, and a hillslope-gradient factor, S. Generally speaking, as hillslope length and/or hillslope gradient increase, soil loss increases. As hillslope length increases, total soil loss and soil loss per unit area increase due to the progressive accumulation of runoff in the downslope direction. As the hillslope gradient increases, the velocity and erosivity of runoff increases. Use the LS table located in separate tab of this spreadsheet to determine LS factors. Estimate the weighted LS for the site prior to construction.</p> <p>LS Table</p>		
LS Factor Value		0
Watershed Erosion Estimate (=RxKxLS) in tons/acre		0
Site Sediment Risk Factor Low Sediment Risk: < 15 tons/acre Medium Sediment Risk: >=15 and <75 tons/acre High Sediment Risk: >= 75 tons/acre		Low

For the GIS Map Method, the R factor for the project is calculated using the online calculator at (see cell to right). The product of K and LS are shown on the figure below. To determine soil loss in tons per acre, multiply the R factor times the value for K times LS from the map.

<http://cfpub.epa.gov/npdes/stormwater/LEW/lewCalculator.cfm>

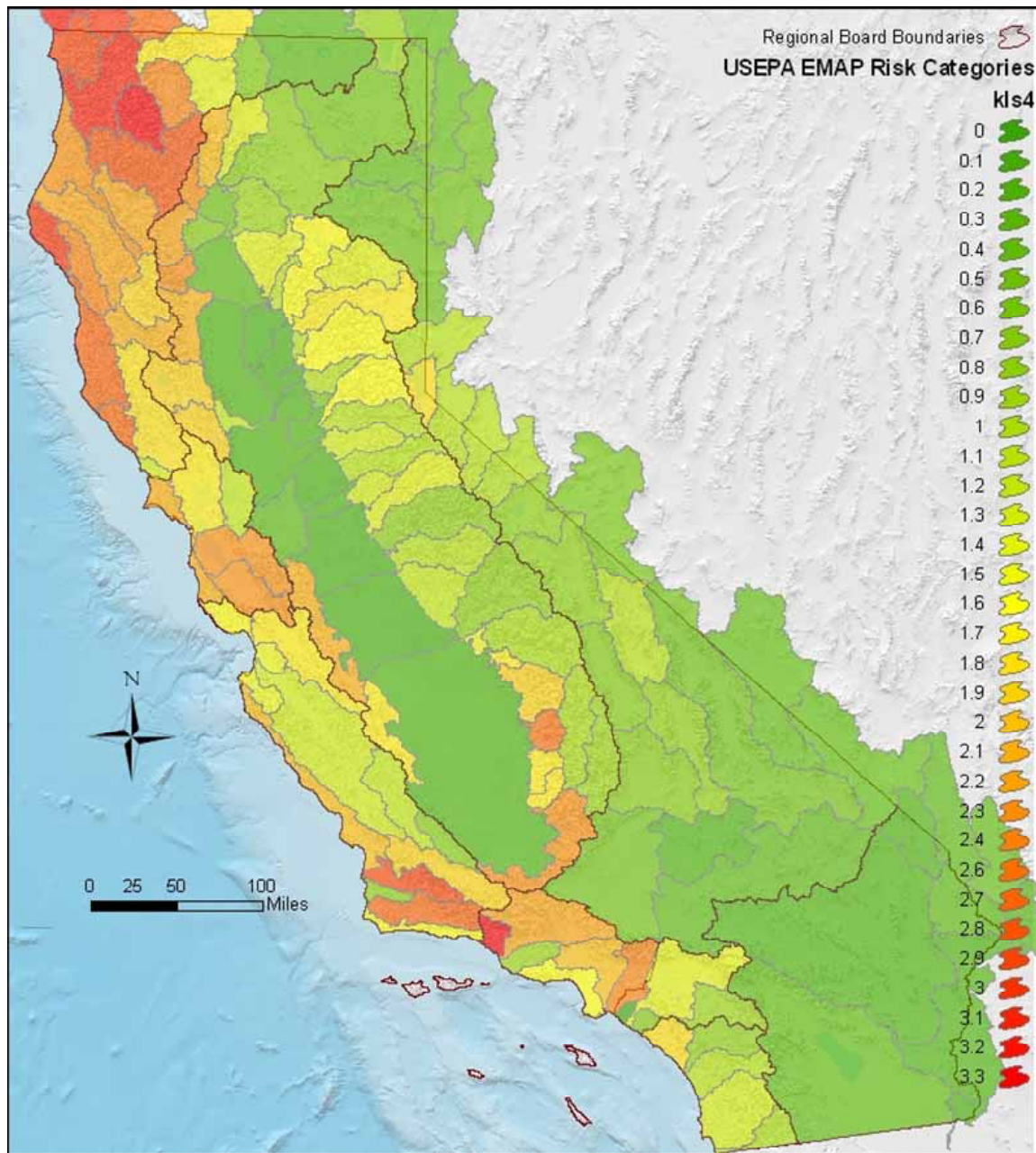

State Water Resources Control Board, January 15, 2008

Receiving Water (RW) Risk Factor Worksheet	Entry	Score
A. Watershed Characteristics	yes/no	
A.1. Does the disturbed area discharge (either directly or indirectly) to a 303(d)-listed waterbody impaired by sediment ? (For help with impaired waterbodies please check the attached worksheet or visit the link below) or has a USEPA approved TMDL implementation plan for sediment ?:	Yes	High
2006 Approved Sediment-impaired WBs Worksheet		
http://www.waterboards.ca.gov/water_issues/programs/tmdl/303d_lists2006_epa.shtml		
OR		
A.2. Does the disturbed area discharge to a waterbody with designated beneficial uses of SPAWN & COLD & MIGRATORY?		
http://www.ice.ucdavis.edu/geowbs/asp/wbquse.asp		

		Combined Risk Level Matrix		
		<u>Sediment Risk</u>		
<u>Receiving Water Risk</u>		Low	Medium	High
	Low	Level 1	Level 2	
High	Level 2		Level 3	

Project Sediment Risk: **Low**

Project RW Risk: **High**

Project Combined Risk: **Level 2**

Soil Erodibility Factor (K)

The K factor can be determined by using the nomograph method, which requires that a particle size analysis (ASTM D-422) be done to determine the percentages of sand, very fine sand, silt and clay. Use the figure below to determine appropriate K value.

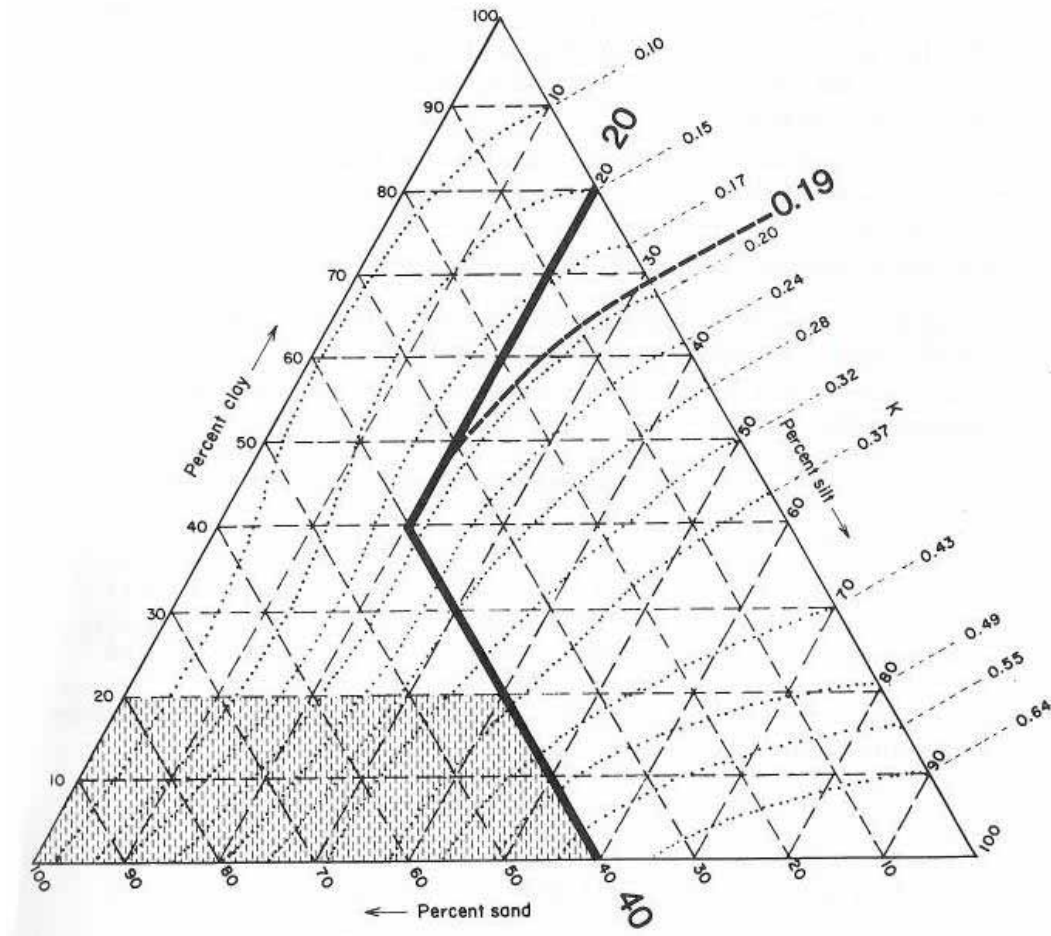

Erickson triangular nomograph used to estimate soil erodibility (K) factor. The figure above is the USDA nomograph used to determine the K factor for a soil, based on its texture (% silt plus very fine sand, % sand, % organic matter, soil structure, and permeability).
Nomograph from Erickson 1977 as referenced in Goldman et. al., 1986.

Sheet Flow Length (ft)	Average Watershed Slope (%)													
	0.2	0.5	1.0	2.0	3.0	4.0	5.0	6.0	8.0	10.0	12.0	14.0	16.0	20.0
<3	0.05	0.07	0.09	0.13	0.17	0.20	0.23	0.26	0.32	0.35	0.36	0.38	0.39	0.41
6	0.05	0.07	0.09	0.13	0.17	0.20	0.23	0.26	0.32	0.37	0.41	0.45	0.49	0.56
9	0.05	0.07	0.09	0.13	0.17	0.20	0.23	0.26	0.32	0.38	0.45	0.51	0.56	0.67
12	0.05	0.07	0.09	0.13	0.17	0.20	0.23	0.26	0.32	0.39	0.47	0.55	0.62	0.76
15	0.05	0.07	0.09	0.13	0.17	0.20	0.23	0.26	0.32	0.40	0.49	0.58	0.67	0.84
25	0.05	0.07	0.10	0.16	0.21	0.26	0.31	0.36	0.45	0.57	0.71	0.85	0.98	1.24
50	0.05	0.08	0.13	0.21	0.30	0.38	0.46	0.54	0.70	0.91	1.15	1.40	1.64	2.10
75	0.05	0.08	0.14	0.25	0.36	0.47	0.58	0.69	0.91	1.20	1.54	1.87	2.21	2.86
100	0.05	0.09	0.15	0.28	0.41	0.55	0.68	0.82	1.10	1.46	1.88	2.31	2.73	3.57
150	0.05	0.09	0.17	0.33	0.50	0.68	0.86	1.05	1.43	1.92	2.51	3.09	3.68	4.85
200	0.06	0.10	0.18	0.37	0.57	0.79	1.02	1.25	1.72	2.34	3.07	3.81	4.56	6.04
250	0.06	0.10	0.19	0.40	0.64	0.89	1.16	1.43	1.99	2.72	3.60	4.48	5.37	7.16
300	0.06	0.10	0.20	0.43	0.69	0.98	1.28	1.60	2.24	3.09	4.09	5.11	6.15	8.23
400	0.06	0.11	0.22	0.48	0.80	1.14	1.51	1.90	2.70	3.75	5.01	6.30	7.60	10.24
600	0.06	0.12	0.24	0.56	0.96	1.42	1.91	2.43	3.52	4.95	6.67	8.45	10.26	13.94
800	0.06	0.12	0.26	0.63	1.10	1.65	2.25	2.89	4.24	6.03	8.17	10.40	12.69	17.35
1000	0.06	0.13	0.27	0.69	1.23	1.86	2.55	3.30	4.91	7.02	9.57	12.23	14.96	20.57

LS Factors for Construction Sites. *Table from Renard et. al., 1997.*

WBID	REGION NUMBER	REGION NAME	WATER BODY TYPE ABBR	WATER BODY TYPE	WATER BODY NAME	CALWATER WATERSHED	ESTIMATED SIZE AFFECTED	UNIT ABBR	UNIT	POLLUTANT CODE	POLLUTANT	SOURCE CODE	POTENTIAL SOURCES	PROPOSED TMDL COMPLETION	COMMENTS
CAR11000 1	North Coast	R	Rivers/Streams	Eureka Plain HU, Freshwater Creek	11000000	84 M	Miles	1100	Sedimentation/Siltation	7600	Removal of Riparian Vegetation	2019	The Eureka Plain HU, Freshwater Creek, includes the following Calwater Planning Watersheds (PWS): 110.00011, 110.00012, 110.00014, 110.00040, and 110.00050. Sedimentation, threat of sedimentation, impaired irrigation water quality, impaired domestic supply water quality, impaired spawning habitat, increased rate and depth of flooding due to sediment, property damage. NCRWQCB and California Department of forestry staff are involved in ongoing efforts to attain adherence to Forest Practice Rules.		
CAR11000 1	North Coast	R	Rivers/Streams	Eureka Plain HU, Freshwater Creek	11000000	84 M	Miles	1100	Sedimentation/Siltation	7700	Streambank Modification/Destabilization	2019	The Eureka Plain HU, Freshwater Creek, includes the following Calwater Planning Watersheds (PWS): 110.00011, 110.00012, 110.00014, 110.00040, and 110.00050. Sedimentation, threat of sedimentation, impaired irrigation water quality, impaired domestic supply water quality, impaired spawning habitat, increased rate and depth of flooding due to sediment, property damage. NCRWQCB and California Department of forestry staff are involved in ongoing efforts to attain adherence to Forest Practice Rules.		
CAR11000 1	North Coast	R	Rivers/Streams	Eureka Plain HU, Freshwater Creek	11000000	84 M	Miles	1100	Sedimentation/Siltation	7820	Erosion/Siltation	2019	The Eureka Plain HU, Freshwater Creek, includes the following Calwater Planning Watersheds (PWS): 110.00011, 110.00012, 110.00014, 110.00040, and 110.00050. Sedimentation, threat of sedimentation, impaired irrigation water quality, impaired domestic supply water quality, impaired spawning habitat, increased rate and depth of flooding due to sediment, property damage. NCRWQCB and California Department of forestry staff are involved in ongoing efforts to attain adherence to Forest Practice Rules.		
CAR11000 1	North Coast	R	Rivers/Streams	Eureka Plain HU, Freshwater Creek	11000000	84 M	Miles	1100	Sedimentation/Siltation	8600	Natural Sources	2019	The Eureka Plain HU, Freshwater Creek, includes the following Calwater Planning Watersheds (PWS): 110.00011, 110.00012, 110.00014, 110.00040, and 110.00050. Sedimentation, threat of sedimentation, impaired irrigation water quality, impaired domestic supply water quality, impaired spawning habitat, increased rate and depth of flooding due to sediment, property damage. NCRWQCB and California Department of forestry staff are involved in ongoing efforts to attain adherence to Forest Practice Rules.		
CAR11000 1	North Coast	R	Rivers/Streams	Eureka Plain HU, Freshwater Creek	11000000	84 M	Miles	1100	Sedimentation/Siltation	9100	Nonpoint Source	2019	The Eureka Plain HU, Freshwater Creek, includes the following Calwater Planning Watersheds (PWS): 110.00011, 110.00012, 110.00014, 110.00040, and 110.00050. Sedimentation, threat of sedimentation, impaired irrigation water quality, impaired domestic supply water quality, impaired spawning habitat, increased rate and depth of flooding due to sediment, property damage. NCRWQCB and California Department of forestry staff are involved in ongoing efforts to attain adherence to Forest Practice Rules.		
CAR10511 1	North Coast	R	Rivers/Streams	Klamath River HU, Lower HA, Klamath Glen HSA	10511000	609 M	Miles	1100	Sedimentation/Siltation	9000	Source Unknown	2019	If this listing is determined to be on tribal lands, USEPA should place this water body and pollutant on the section 303d list for the tribal lands. It is not the State Water Board's intent this listing affect other actions related to decommissioning and removal of dams on the Klamath River		
CAR10910 1	North Coast	R	Rivers/Streams	Mad River HU, Mad River	10900000	654 M	Miles	1100	Sedimentation/Siltation	2000	Silviculture	2019	USEPA will develop TMDL for the Mad River. Sediment TMDLS will be developed for the area tributary to and including: (1) the Mad River (North Fork), (2) the mad River (Upper), (3) the Mad River (Middle).		
CAR10910 1	North Coast	R	Rivers/Streams	Mad River HU, Mad River	10900000	654 M	Miles	1100	Sedimentation/Siltation	5000	Resource Extraction	2019	USEPA will develop TMDL for the Mad River. Sediment TMDLS will be developed for the area tributary to and including: (1) the Mad River (North Fork), (2) the mad River (Upper), (3) the Mad River (Middle).		
CAR10910 1	North Coast	R	Rivers/Streams	Mad River HU, Mad River	10900000	654 M	Miles	1100	Sedimentation/Siltation	9100	Nonpoint Source	2019	USEPA will develop TMDL for the Mad River. Sediment TMDLS will be developed for the area tributary to and including: (1) the Mad River (North Fork), (2) the mad River (Upper), (3) the Mad River (Middle).		
CAR11412 1	North Coast	R	Rivers/Streams	Russian River HU, Lower Russian River HA, Austin Creek HSA	11412000	81 M	Miles	1100	Sedimentation/Siltation	2000	Silviculture	2019	Sediment impacts in Russian River tributaries prompted listing entire Russian River watershed for sediment.		
CAR11412 1	North Coast	R	Rivers/Streams	Russian River HU, Lower Russian River HA, Austin Creek HSA	11412000	81 M	Miles	1100	Sedimentation/Siltation	3000	Construction/Land Development	2019	Sediment impacts in Russian River tributaries prompted listing entire Russian River watershed for sediment.		
CAR11412 1	North Coast	R	Rivers/Streams	Russian River HU, Lower Russian River HA, Austin Creek HSA	11412000	81 M	Miles	1100	Sedimentation/Siltation	3215	Disturbed Sites (Land Develop.)	2019	Sediment impacts in Russian River tributaries prompted listing entire Russian River watershed for sediment.		
CAR11412 1	North Coast	R	Rivers/Streams	Russian River HU, Lower Russian River HA, Austin Creek HSA	11412000	81 M	Miles	1100	Sedimentation/Siltation	7300	Dam Construction	2019	Sediment impacts in Russian River tributaries prompted listing entire Russian River watershed for sediment.		
CAR11412 1	North Coast	R	Rivers/Streams	Russian River HU, Lower Russian River HA, Austin Creek HSA	11412000	81 M	Miles	1100	Sedimentation/Siltation	7400	Flow Regulation/Modification	2019	Sediment impacts in Russian River tributaries prompted listing entire Russian River watershed for sediment.		
CAR11412 1	North Coast	R	Rivers/Streams	Russian River HU, Lower Russian River HA, Austin Creek HSA	11412000	81 M	Miles	1100	Sedimentation/Siltation	7820	Erosion/Siltation	2019	Sediment impacts in Russian River tributaries prompted listing entire Russian River watershed for sediment.		
CAR11411 1	North Coast	R	Rivers/Streams	Russian River HU, Lower Russian River HA, Guerneville HSA	11411000	195 M	Miles	1100	Sedimentation/Siltation	1000	Agriculture	2019	Sediment impacts in Russian River tributaries prompted listing entire Russian River watershed for sediment.		
CAR11411 1	North Coast	R	Rivers/Streams	Russian River HU, Lower Russian River HA, Guerneville HSA	11411000	195 M	Miles	1100	Sedimentation/Siltation	1200	Irrigated Crop Production	2019	Sediment impacts in Russian River tributaries prompted listing entire Russian River watershed for sediment.		
CAR11411 1	North Coast	R	Rivers/Streams	Russian River HU, Lower Russian River HA, Guerneville HSA	11411000	195 M	Miles	1100	Sedimentation/Siltation	1300	Specialty Crop Production	2019	Sediment impacts in Russian River tributaries prompted listing entire Russian River watershed for sediment.		
CAR11411 1	North Coast	R	Rivers/Streams	Russian River HU, Lower Russian River HA, Guerneville HSA	11411000	195 M	Miles	1100	Sedimentation/Siltation	1915	Agriculture-storm runoff	2019	Sediment impacts in Russian River tributaries prompted listing entire Russian River watershed for sediment.		
CAR11411 1	North Coast	R	Rivers/Streams	Russian River HU, Lower Russian River HA, Guerneville HSA	11411000	195 M	Miles	1100	Sedimentation/Siltation	1935	Agriculture-grazing	2019	Sediment impacts in Russian River tributaries prompted listing entire Russian River watershed for sediment.		
CAR11411 1	North Coast	R	Rivers/Streams	Russian River HU, Lower Russian River HA, Guerneville HSA	11411000	195 M	Miles	1100	Sedimentation/Siltation	2000	Silviculture	2019	Sediment impacts in Russian River tributaries prompted listing entire Russian River watershed for sediment.		
CAR11411 1	North Coast	R	Rivers/Streams	Russian River HU, Lower Russian River HA, Guerneville HSA	11411000	195 M	Miles	1100	Sedimentation/Siltation	3000	Construction/Land Development	2019	Sediment impacts in Russian River tributaries prompted listing entire Russian River watershed for sediment.		
CAR11411 1	North Coast	R	Rivers/Streams	Russian River HU, Lower Russian River HA, Guerneville HSA	11411000	195 M	Miles	1100	Sedimentation/Siltation	3100	Highway/Road/Bridge Construction	2019	Sediment impacts in Russian River tributaries prompted listing entire Russian River watershed for sediment.		
CAR11411 1	North Coast	R	Rivers/Streams	Russian River HU, Lower Russian River HA, Guerneville HSA	11411000	195 M	Miles	1100	Sedimentation/Siltation	3200	Land Development	2019	Sediment impacts in Russian River tributaries prompted listing entire Russian River watershed for sediment.		
CAR11411 1	North Coast	R	Rivers/Streams	Russian River HU, Lower Russian River HA, Guerneville HSA	11411000	195 M	Miles	1100	Sedimentation/Siltation	7000	Hydromodification	2019	Sediment impacts in Russian River tributaries prompted listing entire Russian River watershed for sediment.		
CAR11411 1	North Coast	R	Rivers/Streams	Russian River HU, Lower Russian River HA, Guerneville HSA	11411000	195 M	Miles	1100	Sedimentation/Siltation	7100	Channelization	2019	Sediment impacts in Russian River tributaries prompted listing entire Russian River watershed for sediment.		
CAR11411 1	North Coast	R	Rivers/Streams	Russian River HU, Lower Russian River HA, Guerneville HSA	11411000	195 M	Miles	1100	Sedimentation/Siltation	7300	Dam Construction	2019	Sediment impacts in Russian River tributaries prompted listing entire Russian River watershed for sediment.		
CAR11411 1	North Coast	R	Rivers/Streams	Russian River HU, Lower Russian River HA, Guerneville HSA	11411000	195 M	Miles	1100	Sedimentation/Siltation	7350	Upstream Impoundment	2019	Sediment impacts in Russian River tributaries prompted listing entire Russian River watershed for sediment.		
CAR11411 1	North Coast	R	Rivers/Streams	Russian River HU, Lower Russian River HA, Guerneville HSA	11411000	195 M	Miles	1100	Sedimentation/Siltation	7400	Flow Regulation/Modification	2019	Sediment impacts in Russian River tributaries prompted listing entire Russian River watershed for sediment.		
CAR11411 1	North Coast	R	Rivers/Streams	Russian River HU, Lower Russian River HA, Guerneville HSA	11411000	195 M	Miles	1100	Sedimentation/Siltation	7550	Habitat Modification	2019	Sediment impacts in Russian River tributaries prompted listing entire Russian River watershed for sediment.		
CAR11411 1	North Coast	R	Rivers/Streams	Russian River HU, Lower Russian River HA, Guerneville HSA	11411000	195 M	Miles	1100	Sedimentation/Siltation	7600	Removal of Riparian Vegetation	2019	Sediment impacts in Russian River tributaries prompted listing entire Russian River watershed for sediment.		
CAR11411 1	North Coast	R	Rivers/Streams	Russian River HU, Lower Russian River HA, Guerneville HSA	11411000	195 M	Miles	1100	Sedimentation/Siltation	7700	Streambank Modification/Destabilization	2019	Sediment impacts in Russian River tributaries prompted listing entire Russian River watershed for sediment.		
CAR11411 1	North Coast	R	Rivers/Streams	Russian River HU, Lower Russian River HA, Guerneville HSA	11411000	195 M	Miles	1100	Sedimentation/Siltation	7800	Drainage/Filling Of Wetlands	2019	Sediment impacts in Russian River tributaries prompted listing entire Russian River watershed for sediment.		
CAR11411 1	North Coast	R	Rivers/Streams	Russian River HU, Lower Russian River HA, Guerneville HSA	11411000	195 M	Miles	1100	Sedimentation/Siltation	7810	Channel Erosion	2019	Sediment impacts in Russian River tributaries prompted listing entire Russian River watershed for sediment.		
CAR11411 1	North Coast	R	Rivers/Streams	Russian River HU, Lower Russian River HA, Guerneville HSA	11411000	195 M	Miles	1100	Sedimentation/Siltation	7820	Erosion/Siltation	2019	Sediment impacts in Russian River tributaries prompted listing entire Russian River watershed for sediment.		
CAR11426 1	North Coast	R	Rivers/Streams	Sulphur Creek HSA	11426000	85 M	Miles	1100	Sedimentation/Siltation	3210	Geothermal Development	2019	Sediment impacts in Russian River tributaries prompted listing entire Russian River watershed for sediment.		
CAR11426 1	North Coast	R	Rivers/Streams	Russian River HU, Middle Russian River HA, Big Sulphur Creek HSA	11426000	85 M	Miles	1100	Sedimentation/Siltation	7820	Erosion/Siltation	2019	Sediment impacts in Russian River tributaries prompted listing entire Russian River watershed for sediment.		
CAR11426 1	North Coast	R	Rivers/Streams	Russian River HU, Middle Russian River HA, Big Sulphur Creek HSA	11426000	85 M	Miles	1100	Sedimentation/Siltation	9100	Nonpoint Source	2019	Sediment impacts in Russian River tributaries prompted listing entire Russian River watershed for sediment.		

WBID	REGION NUMBER	REGION NAME	WATER BODY TYPE ABBR	WATER BODY TYPE	WATER BODY NAME	CALWATER WATERSHED	ESTIMATED SIZE AFFECTED	UNIT ABBR	UNIT	POLLUTANT CODE	POLLUTANT	SOURCE CODE	POTENTIAL SOURCES	PROPOSED TMDL COMPLETION	COMMENTS
CAR11423 1	North Coast	R	Rivers/Streams	Russian River HU, Middle Russian River HA, Mark West Creek HSA	11423000	99 M	Miles	1100	Sedimentation/Siltation	7600	Removal of Riparian Vegetation	2019	Russian River Watershed tributary sediment impairments led to listing of entire watershed for sediment .		
CAR11423 1	North Coast	R	Rivers/Streams	Russian River HU, Middle Russian River HA, Mark West Creek HSA	11423000	99 M	Miles	1100	Sedimentation/Siltation	7700	Streambank Modification/Destabilization	2019	Russian River Watershed tributary sediment impairments led to listing of entire watershed for sediment .		
CAR11423 1	North Coast	R	Rivers/Streams	Russian River HU, Middle Russian River HA, Mark West Creek HSA	11423000	99 M	Miles	1100	Sedimentation/Siltation	7800	Drainage/Filling Of Wetlands	2019	Russian River Watershed tributary sediment impairments led to listing of entire watershed for sediment .		
CAR11423 1	North Coast	R	Rivers/Streams	Russian River HU, Middle Russian River HA, Mark West Creek HSA	11423000	99 M	Miles	1100	Sedimentation/Siltation	7810	Channel Erosion	2019	Russian River Watershed tributary sediment impairments led to listing of entire watershed for sediment .		
CAR11421 1	North Coast	R	Rivers/Streams	Russian River HU, Middle Russian River HA, Laguna de Santa Rosa	11421000	96 M	Miles	1100	Sedimentation/Siltation	4300	Other Urban Runoff	2019	Entire Russian River watershed (including Laguna de Santa Rosa) is listed for sedimentation.		
CAR11421 1	North Coast	R	Rivers/Streams	Russian River HU, Middle Russian River HA, Laguna de Santa Rosa	11421000	96 M	Miles	1100	Sedimentation/Siltation	4500	Highway/Road/Bridge Runoff	2019	Entire Russian River watershed (including Laguna de Santa Rosa) is listed for sedimentation.		
CAR11421 1	North Coast	R	Rivers/Streams	Russian River HU, Middle Russian River HA, Laguna de Santa Rosa	11421000	96 M	Miles	1100	Sedimentation/Siltation	7000	Hydromodification	2019	Entire Russian River watershed (including Laguna de Santa Rosa) is listed for sedimentation.		
CAR11421 1	North Coast	R	Rivers/Streams	Russian River HU, Middle Russian River HA, Laguna de Santa Rosa	11421000	96 M	Miles	1100	Sedimentation/Siltation	7100	Channelization	2019	Entire Russian River watershed (including Laguna de Santa Rosa) is listed for sedimentation.		
CAR11421 1	North Coast	R	Rivers/Streams	Russian River HU, Middle Russian River HA, Laguna de Santa Rosa	11421000	96 M	Miles	1100	Sedimentation/Siltation	7600	Removal of Riparian Vegetation	2019	Entire Russian River watershed (including Laguna de Santa Rosa) is listed for sedimentation.		
CAR11421 1	North Coast	R	Rivers/Streams	Russian River HU, Middle Russian River HA, Laguna de Santa Rosa	11421000	96 M	Miles	1100	Sedimentation/Siltation	7700	Streambank Modification/Destabilization	2019	Entire Russian River watershed (including Laguna de Santa Rosa) is listed for sedimentation.		
CAR11421 1	North Coast	R	Rivers/Streams	Russian River HU, Middle Russian River HA, Laguna de Santa Rosa	11421000	96 M	Miles	1100	Sedimentation/Siltation	7800	Drainage/Filling Of Wetlands	2019	Entire Russian River watershed (including Laguna de Santa Rosa) is listed for sedimentation.		
CAR11421 1	North Coast	R	Rivers/Streams	Russian River HU, Middle Russian River HA, Laguna de Santa Rosa	11421000	96 M	Miles	1100	Sedimentation/Siltation	7810	Channel Erosion	2019	Entire Russian River watershed (including Laguna de Santa Rosa) is listed for sedimentation.		
CAR11421 1	North Coast	R	Rivers/Streams	Russian River HU, Middle Russian River HA, Laguna de Santa Rosa	11421000	96 M	Miles	1100	Sedimentation/Siltation	7820	Erosion/Siltation	2019	Entire Russian River watershed (including Laguna de Santa Rosa) is listed for sedimentation.		
CAR11421 1	North Coast	R	Rivers/Streams	Russian River HU, Middle Russian River HA, Laguna de Santa Rosa	11421000	96 M	Miles	1100	Sedimentation/Siltation	8050	Erosion From Derelict Land	2019	Entire Russian River watershed (including Laguna de Santa Rosa) is listed for sedimentation.		
CAR11421 1	North Coast	R	Rivers/Streams	Russian River HU, Middle Russian River HA, Laguna de Santa Rosa	11421000	96 M	Miles	1100	Sedimentation/Siltation	8300	Highway Maintenance and Runoff	2019	Entire Russian River watershed (including Laguna de Santa Rosa) is listed for sedimentation.		
CAR11421 1	North Coast	R	Rivers/Streams	Russian River HU, Middle Russian River HA, Laguna de Santa Rosa	11421000	96 M	Miles	1100	Sedimentation/Siltation	9100	Nonpoint Source	2019	Entire Russian River watershed (including Laguna de Santa Rosa) is listed for sedimentation.		
CAR30411 3	Central Coast	R	Rivers/Streams	San Vicente Creek	30411023	9.11953 M	Miles	1100	Sedimentation/Siltation	2000	Silviculture	2019	Entire Russian River watershed (including Laguna de Santa Rosa) is listed for sedimentation.		
CAR31410 3	Central Coast	R	Rivers/Streams	Santa Ynez River (below city of Lompoc to Ocean)	31410040	3.8 M	Miles	1100	Sedimentation/Siltation	1000	Agriculture	2019			
CAR31410 3	Central Coast	R	Rivers/Streams	Santa Ynez River (below city of Lompoc to Ocean)	31410040	3.8 M	Miles	1100	Sedimentation/Siltation	4000	Urban Runoff/Storm Sewers	2019			
CAR31410 3	Central Coast	R	Rivers/Streams	Santa Ynez River (Cachuma Lake to below city o Lompoc)	31410040	3.8 M	Miles	1100	Sedimentation/Siltation	5000	Resource Extraction	2019			
CAR31410 3	Central Coast	R	Rivers/Streams	Santa Ynez River (Cachuma Lake to below city o Lompoc)	31440050	43 M	Miles	1100	Sedimentation/Siltation	1000	Agriculture	2019			
CAR31410 3	Central Coast	R	Rivers/Streams	Santa Ynez River (Cachuma Lake to below city o Lompoc)	31440050	43 M	Miles	1100	Sedimentation/Siltation	4000	Urban Runoff/Storm Sewers	2019			
CAR31410 3	Central Coast	R	Rivers/Streams	Santa Ynez River (Cachuma Lake to below city o Lompoc)	31440050	43 M	Miles	1100	Sedimentation/Siltation	5000	Resource Extraction	2019			
CAR31300 3	Central Coast	R	Rivers/Streams	Shuman Canyon Creek	31300041	8.5496 M	Miles	1100	Sedimentation/Siltation	9000	Source Unknown	2019			
CAR30413 3	Central Coast	R	Rivers/Streams	Valencia Creek	30413023	6.19 M	Miles	1100	Sedimentation/Siltation	1000	Agriculture	2008			
CAR30413 3	Central Coast	R	Rivers/Streams	Valencia Creek	30413023	6.19 M	Miles	1100	Sedimentation/Siltation	3000	Construction/Land Development	2008			
CAR30412 3	Central Coast	R	Rivers/Streams	Zayante Creek	30412040	9.20875 M	Miles	1100	Sedimentation/Siltation	1000	Agriculture	2019			
CAR30412 3	Central Coast	R	Rivers/Streams	Zayante Creek	30412040	9.20875 M	Miles	1100	Sedimentation/Siltation	2000	Silviculture	2019			
CAR30412 3	Central Coast	R	Rivers/Streams	Zayante Creek	30412040	9.20875 M	Miles	1100	Sedimentation/Siltation	3110	Road Construction	2019			
CAR30412 3	Central Coast	R	Rivers/Streams	Zayante Creek	30412040	9.20875 M	Miles	1100	Sedimentation/Siltation	3215	Disturbed Sites (Land Develop.)	2019			
CAR30412 3	Central Coast	R	Rivers/Streams	Zayante Creek	30412040	9.20875 M	Miles	1100	Sedimentation/Siltation	7820	Erosion/Siltation	2019			
CAR30412 3	Central Coast	R	Rivers/Streams	Zayante Creek	30412040	9.20875 M	Miles	1100	Sedimentation/Siltation	9100	Nonpoint Source	2019			
CAR11423 1	North Coast	R	Rivers/Streams	Russian River HU, Middle Russian River HA, Mark West Creek HSA	11423000	99 M	Miles	1100	Sedimentation/Siltation	7820	Erosion/Siltation	2019	Russian River Watershed tributary sediment impairments led to listing of entire watershed for sediment .		
CAR11422 1	North Coast	R	Rivers/Streams	Russian River HU, Middle Russian River HA, Santa Rosa Creek	11422000	87 M	Miles	1100	Sedimentation/Siltation	1000	Agriculture	2019	Entire Russian River watershed (including Santa Rosa Creek) is listed for sedimentation.		
CAR11422 1	North Coast	R	Rivers/Streams	Russian River HU, Middle Russian River HA, Santa Rosa Creek	11422000	87 M	Miles	1100	Sedimentation/Siltation	1100	Nonirrigated Crop Production	2019	Entire Russian River watershed (including Santa Rosa Creek) is listed for sedimentation.		
CAR11422 1	North Coast	R	Rivers/Streams	Russian River HU, Middle Russian River HA, Santa Rosa Creek	11422000	87 M	Miles	1100	Sedimentation/Siltation	1200	Irrigated Crop Production	2019	Entire Russian River watershed (including Santa Rosa Creek) is listed for sedimentation.		
CAR11422 1	North Coast	R	Rivers/Streams	Russian River HU, Middle Russian River HA, Santa Rosa Creek	11422000	87 M	Miles	1100	Sedimentation/Siltation	1300	Specialty Crop Production	2019	Entire Russian River watershed (including Santa Rosa Creek) is listed for sedimentation.		
CAR11422 1	North Coast	R	Rivers/Streams	Russian River HU, Middle Russian River HA, Santa Rosa Creek	11422000	87 M	Miles	1100	Sedimentation/Siltation	1400	Pasture Grazing-Riparian and/or Upland	2019	Entire Russian River watershed (including Santa Rosa Creek) is listed for sedimentation.		
CAR11422 1	North Coast	R	Rivers/Streams	Russian River HU, Middle Russian River HA, Santa Rosa Creek	11422000	87 M	Miles	1100	Sedimentation/Siltation	1510	Range Grazing-Riparian	2019	Entire Russian River watershed (including Santa Rosa Creek) is listed for sedimentation.		
CAR11422 1	North Coast	R	Rivers/Streams	Russian River HU, Middle Russian River HA, Santa Rosa Creek	11422000	87 M	Miles	1100	Sedimentation/Siltation	1520	Range Grazing-Upland	2019	Entire Russian River watershed (including Santa Rosa Creek) is listed for sedimentation.		
CAR11422 1	North Coast	R	Rivers/Streams	Russian River HU, Middle Russian River HA, Santa Rosa Creek	11422000	87 M	Miles	1100	Sedimentation/Siltation	1940	Dairies	2019	Entire Russian River watershed (including Santa Rosa Creek) is listed for sedimentation.		
CAR11422 1	North Coast	R	Rivers/Streams	Russian River HU, Middle Russian River HA, Santa Rosa Creek	11422000	87 M	Miles	1100	Sedimentation/Siltation	3000	Construction/Land Development	2019	Entire Russian River watershed (including Santa Rosa Creek) is listed for sedimentation.		
CAR11422 1	North Coast	R	Rivers/Streams	Russian River HU, Middle Russian River HA, Santa Rosa Creek	11422000	87 M	Miles	1100	Sedimentation/Siltation	3100	Highway/Road/Bridge Construction	2019	Entire Russian River watershed (including Santa Rosa Creek) is listed for sedimentation.		
CAR11422 1	North Coast	R	Rivers/Streams	Russian River HU, Middle Russian River HA, Santa Rosa Creek	11422000	87 M	Miles	1100	Sedimentation/Siltation	3200	Land Development	2019	Entire Russian River watershed (including Santa Rosa Creek) is listed for sedimentation.		
CAR11422 1	North Coast	R	Rivers/Streams	Russian River HU, Middle Russian River HA, Santa Rosa Creek	11422000	87 M	Miles	1100	Sedimentation/Siltation	4000	Urban Runoff/Storm Sewers	2019	Entire Russian River watershed (including Santa Rosa Creek) is listed for sedimentation.		
CAR11422 1	North Coast	R	Rivers/Streams	Russian River HU, Middle Russian River HA, Santa Rosa Creek	11422000	87 M	Miles	1100	Sedimentation/Siltation	4100	Urban Runoff-Non-Industrial Permitted	2019	Entire Russian River watershed (including Santa Rosa Creek) is listed for sedimentation.		
CAR11422 1	North Coast	R	Rivers/Streams	Russian River HU, Middle Russian River HA, Santa Rosa Creek	11422000	87 M	Miles	1100	Sedimentation/Siltation	4300	Other Urban Runoff	2019	Entire Russian River watershed (including Santa Rosa Creek) is listed for sedimentation.		
CAR11422 1	North Coast	R	Rivers/Streams	Russian River HU, Middle Russian River HA, Santa Rosa Creek	11422000	87 M	Miles	1100	Sedimentation/Siltation	4501	Surface Runoff	2019	Entire Russian River watershed (including Santa Rosa Creek) is listed for sedimentation.		

WBID	REGION NUMBER	REGION NAME	WATER BODY TYPE ABBR	WATER BODY TYPE	WATER BODY NAME	CALWATER WATERSHED	ESTIMATED SIZE AFFECTED	UNIT ABBR	UNIT	POLLUTANT CODE	POLLUTANT	SOURCE CODE	POTENTIAL SOURCES	PROPOSED TMDL COMPLETION	COMMENTS
CAR11432 1	North Coast	R	Rivers/Streams	Russian River HU, Upper Russian River HA, Coyote Valley HSA	11432000	171 M	Miles	1100	Sedimentation/Siltation	7820	Erosion/Siltation	2019	Russian River Watershed tributary sediment impairments led to listing of entire watershed for sediment .		
CAR11433 1	North Coast	R	Rivers/Streams	Russian River HU, Upper Russian River HA, Forsythe Creek HSA	11433000	122 M	Miles	1100	Sedimentation/Siltation	7820	Erosion/Siltation	2019	Russian River Watershed tributary sediment impairments led to listing of entire watershed for sediment .		
CAR11433 1	North Coast	R	Rivers/Streams	Russian River HU, Upper Russian River HA, Forsythe Creek HSA	11433000	122 M	Miles	1100	Sedimentation/Siltation	9100	Nonpoint Source	2019	Russian River Watershed tributary sediment impairments led to listing of entire watershed for sediment .		
CAR11431 1	North Coast	R	Rivers/Streams	Russian River HU, Upper Russian River HA, Ukiah HSA	11431000	460 M	Miles	1100	Sedimentation/Siltation	1000	Agriculture	2019	Russian River Watershed tributary sediment impairments led to listing of entire watershed for sediment .		
CAR11431 1	North Coast	R	Rivers/Streams	Russian River HU, Upper Russian River HA, Ukiah HSA	11431000	460 M	Miles	1100	Sedimentation/Siltation	2000	Silviculture	2019	Russian River Watershed tributary sediment impairments led to listing of entire watershed for sediment .		
CAR11431 1	North Coast	R	Rivers/Streams	Russian River HU, Upper Russian River HA, Ukiah HSA	11431000	460 M	Miles	1100	Sedimentation/Siltation	3000	Construction/Land Development	2019	Russian River Watershed tributary sediment impairments led to listing of entire watershed for sediment .		
CAR11431 1	North Coast	R	Rivers/Streams	Russian River HU, Upper Russian River HA, Ukiah HSA	11431000	460 M	Miles	1100	Sedimentation/Siltation	5000	Resource Extraction	2019	Russian River Watershed tributary sediment impairments led to listing of entire watershed for sediment .		
CAR11431 1	North Coast	R	Rivers/Streams	Russian River HU, Upper Russian River HA, Ukiah HSA	11431000	460 M	Miles	1100	Sedimentation/Siltation	7550	Habitat Modification	2019	Russian River Watershed tributary sediment impairments led to listing of entire watershed for sediment .		
CAR11431 1	North Coast	R	Rivers/Streams	Russian River HU, Upper Russian River HA, Ukiah HSA	11431000	460 M	Miles	1100	Sedimentation/Siltation	7600	Removal of Riparian Vegetation	2019	Russian River Watershed tributary sediment impairments led to listing of entire watershed for sediment .		
CAR11431 1	North Coast	R	Rivers/Streams	Russian River HU, Upper Russian River HA, Ukiah HSA	11431000	460 M	Miles	1100	Sedimentation/Siltation	7700	Streambank Modification/Destabilization	2019	Russian River Watershed tributary sediment impairments led to listing of entire watershed for sediment .		
CAR11431 1	North Coast	R	Rivers/Streams	Russian River HU, Upper Russian River HA, Ukiah HSA	11431000	460 M	Miles	1100	Sedimentation/Siltation	7800	Drainage/Filling Of Wetlands	2019	Russian River Watershed tributary sediment impairments led to listing of entire watershed for sediment .		
CAR11431 1	North Coast	R	Rivers/Streams	Russian River HU, Upper Russian River HA, Ukiah HSA	11431000	460 M	Miles	1100	Sedimentation/Siltation	7810	Channel Erosion	2019	Russian River Watershed tributary sediment impairments led to listing of entire watershed for sediment .		
CAR11431 1	North Coast	R	Rivers/Streams	Russian River HU, Upper Russian River HA, Ukiah HSA	11431000	460 M	Miles	1100	Sedimentation/Siltation	7820	Erosion/Siltation	2019	Russian River Watershed tributary sediment impairments led to listing of entire watershed for sediment .		
CAR11431 1	North Coast	R	Rivers/Streams	Russian River HU, Upper Russian River HA, Ukiah HSA	11431000	460 M	Miles	1100	Sedimentation/Siltation	8300	Highway Maintenance and Runoff	2019	Russian River Watershed tributary sediment impairments led to listing of entire watershed for sediment .		
CAR11431 1	North Coast	R	Rivers/Streams	Russian River HU, Upper Russian River HA, Ukiah HSA	11431000	460 M	Miles	1100	Sedimentation/Siltation	8600	Natural Sources	2019	Russian River Watershed tributary sediment impairments led to listing of entire watershed for sediment .		
CAB20114 2	San Francisco Bay	B	Bays and Harbors	Tomales Bay	20114033	8545.46 A	Acres	1100	Sedimentation/Siltation	1000	Agriculture	2008	TMDL will be developed as part of ongoing watershed management effort. Tributary streams, Lagunitas Creek and Walker Creek, must be managed first. Additional monitoring and assessment needed.		
CAB20114 2	San Francisco Bay	B	Bays and Harbors	Tomales Bay	20114033	8545.46 A	Acres	1100	Sedimentation/Siltation	7350	Upstream Impoundment	2008	TMDL will be developed as part of ongoing watershed management effort. Tributary streams, Lagunitas Creek and Walker Creek, must be managed first. Additional monitoring and assessment needed.		
CAR20240 2	San Francisco Bay	R	Rivers/Streams	Butano Creek	20240031	3,627.74 M	Miles	1100	Sedimentation/Siltation	9100	Nonpoint Source	2019	Impairment to steelhead habita		
CAR20113 2	San Francisco Bay	R	Rivers/Streams	Lagunitas Creek	20113020	13,757.3 M	Miles	1100	Sedimentation/Siltation	4000	Agriculture	2009	Tributary to Tomales Bay. TMDLs will be developed as part of evolving watershed management effort. Additional monitoring and assessment nee		
CAR20113 2	San Francisco Bay	R	Rivers/Streams	Lagunitas Creek	20113020	16.75 M	Miles	1100	Sedimentation/Siltation	4000	Urban Runoff/Storm Sewers	2009	Tributary to Tomales Bay. TMDLs will be developed as part of evolving watershed management effort. Additional monitoring and assessment nee		
CAR20650 2	San Francisco Bay	R	Rivers/Streams	Napa River	20650010	65.33 M	Miles	1100	Sedimentation/Siltation	1000	Agriculture	2006	TMDL will be developed as part of ongoing watershed management effort. Additional monitoring and assessment nee		
CAR20650 2	San Francisco Bay	R	Rivers/Streams	Napa River	20650010	65.33 M	Miles	1100	Sedimentation/Siltation	3000	Construction/Land Development	2006	TMDL will be developed as part of ongoing watershed management effort. Additional monitoring and assessment nee		
CAR20650 2	San Francisco Bay	R	Rivers/Streams	Napa River	20650010	65.33 M	Miles	1100	Sedimentation/Siltation	3200	Land Development	2006	TMDL will be developed as part of ongoing watershed management effort. Additional monitoring and assessment nee		
CAR20650 2	San Francisco Bay	R	Rivers/Streams	Napa River	20650010	65.33 M	Miles	1100	Sedimentation/Siltation	4000	Urban Runoff/Storm Sewers	2006	TMDL will be developed as part of ongoing watershed management effort. Additional monitoring and assessment nee		
CAR20240 2	San Francisco Bay	R	Rivers/Streams	Pescadero Creek	20240013	26.03 M	Miles	1100	Sedimentation/Siltation	9100	Nonpoint Source	2019	If California Department of Fish and Game and the National Marine Fisheries Service find that for this water body fish populations are not impacted, the State Water Board supp removing this water body and pollutant from the list.		
CAR20630 2	San Francisco Bay	R	Rivers/Streams	Petaluma River	20630020	21,566 M	Miles	1100	Sedimentation/Siltation	1000	Agriculture	2019			
CAR20630 2	San Francisco Bay	R	Rivers/Streams	Petaluma River	20630020	21,566 M	Miles	1100	Sedimentation/Siltation	3000	Construction/Land Development	2019			
CAR20630 2	San Francisco Bay	R	Rivers/Streams	Petaluma River	20630020	21,566 M	Miles	1100	Sedimentation/Siltation	4000	Urban Runoff/Storm Sewers	2019			
CAR20550 2	San Francisco Bay	R	Rivers/Streams	San Francisco Bay	20550040	12.05 M	Miles	1100	Sedimentation/Siltation	9100	Nonpoint Source	2008	Impairment to steelhead habita		
CAR20230 2	San Francisco Bay	R	Rivers/Streams	San Gregorio Creek	20230014	11.14 M	Miles	1100	Sedimentation/Siltation	9100	Nonpoint Source	2019	Impairment to steelhead habita		
CAR20640 2	San Francisco Bay	R	Rivers/Streams	Sonoma Creek	20640050	30.23 M	Miles	1100	Sedimentation/Siltation	1000	Agriculture	2008	TMDL will be developed as part of ongoing watershed management effort. Additional monitoring and assessment nee		
CAR20640 2	San Francisco Bay	R	Rivers/Streams	Sonoma Creek	20640050	30.23 M	Miles	1100	Sedimentation/Siltation	3000	Construction/Land Development	2008	TMDL will be developed as part of ongoing watershed management effort. Additional monitoring and assessment nee		
CAR20640 2	San Francisco Bay	R	Rivers/Streams	Sonoma Creek	20640050	30.23 M	Miles	1100	Sedimentation/Siltation	3200	Land Development	2008	TMDL will be developed as part of ongoing watershed management effort. Additional monitoring and assessment nee		
CAR20640 2	San Francisco Bay	R	Rivers/Streams	Sonoma Creek	20640050	30.23 M	Miles	1100	Sedimentation/Siltation	4000	Urban Runoff/Storm Sewers	2008	TMDL will be developed as part of ongoing watershed management effort. Additional monitoring and assessment nee		
CAR20112 2	San Francisco Bay	R	Rivers/Streams	Walker Creek	20112013	15,835.2 M	Miles	1100	Sedimentation/Siltation	1000	Agriculture	2009	Tributary to Tomales Bay. TMDLs will be developed as part of evolving watershed management effort. Additional monitoring and assessment nee		
CAB30600 3	Central Coast	B	Bays and Harbors	Moss Landing Harbor	30600014	79,272.6 A	Acres	1100	Sedimentation/Siltation	1000	Agriculture	2019			
CAB30600 3	Central Coast	B	Bays and Harbors	Moss Landing Harbor	30600014	79,272.6 A	Acres	1100	Sedimentation/Siltation	1200	Irrigated Crop Production	2019			
CAB30600 3	Central Coast	B	Bays and Harbors	Moss Landing Harbor	30600014	79,272.6 A	Acres	1100	Sedimentation/Siltation	1915	Agriculture-storm runoff	2019			
CAB30600 3	Central Coast	B	Bays and Harbors	Moss Landing Harbor	30600014	79,272.6 A	Acres	1100	Sedimentation/Siltation	7000	Hydromodification	2019			
CAB30600 3	Central Coast	B	Bays and Harbors	Moss Landing Harbor	30600014	79,272.6 A	Acres	1100	Sedimentation/Siltation	7200	Dredging	2019			
CAB30600 3	Central Coast	B	Bays and Harbors	Moss Landing Harbor	30600014	79,272.6 A	Acres	1100	Sedimentation/Siltation	7810	Channel Erosion	2019			
CAB30600 3	Central Coast	B	Bays and Harbors	Moss Landing Harbor	30600014	79,272.6 A	Acres	1100	Sedimentation/Siltation	7820	Erosion/Siltation	2019			
CAB30600 3	Central Coast	B	Bays and Harbors	Moss Landing Harbor	30600014	79,272.6 A	Acres	1100	Sedimentation/Siltation	9100	Nonpoint Source	2019			
CAE30600 3	Central Coast	E	Estuaries	Elkhorn Slough	30600014	2033.73 A	Acres	1100	Sedimentation/Siltation	1000	Agriculture	2015			
CAE30600 3	Central Coast	E	Estuaries	Elkhorn Slough	30600014	2033.73 A	Acres	1100	Sedimentation/Siltation	1200	Irrigated Crop Production	2015			
CAE30600 3	Central Coast	E	Estuaries	Elkhorn Slough	30600014	2033.73 A	Acres	1100	Sedimentation/Siltation	1915	Agriculture-storm runoff	2015			
CAE30600 3	Central Coast	E	Estuaries	Elkhorn Slough	30600014	2033.73 A	Acres	1100	Sedimentation/Siltation	7810	Channel Erosion	2015			
CAE30600 3	Central Coast	E	Estuaries	Elkhorn Slough	30600014	2033.73 A	Acres	1100	Sedimentation/Siltation	9100	Nonpoint Source	2015			
CAE30600 3	Central Coast	E	Estuaries	Moro Cojo Slough	30913011	62,494.9 A	Acres	1100	Sedimentation/Siltation	1000	Agriculture	2019			
CAE30600 3	Central Coast	E	Estuaries	Moro Cojo Slough	30913011	62,494.9 A	Acres	1100	Sedimentation/Siltation	1200	Irrigated Crop Production	2019			
CAE30600 3	Central Coast	E	Estuaries	Moro Cojo Slough	30913011	62,494.9 A	Acres	1100	Sedimentation/Siltation	1915	Agriculture-storm runoff	2019			
CAE30600 3	Central Coast	E	Estuaries	Moro Cojo Slough	30913011	62,494.9 A	Acres	1100	Sedimentation/Siltation	3000	Construction/Land Development	2019			
CAE30600 3	Central Coast	E	Estuaries	Moro Cojo Slough	30913011	62,494.9 A	Acres	1100	Sedimentation/Siltation	9100	Nonpoint Source	2019			
CAR30413 3	Central Coast	R	Rivers/Streams	Souquel Lagoon	30413014	1,158.73 A	Acres	1100	Sedimentation/Siltation	3000	Construction/Land Development	2011			
CAR30413 3	Central Coast	R	Rivers/Streams	Aptos Creek	30413023	8,405.89 M	Miles	1100	Sedimentation/Siltation	3215	Disturbed Sites (Land Develop.)	2008			
CAR30413 3	Central Coast	R	Rivers/Streams	Aptos Creek	30413023	8,405.89 M	Miles	1100	Sedimentation/Siltation	7810	Channel Erosion	2008			
CAR30412 3	Central Coast	R	Rivers/Streams	Bean Creek	30412041	8,907.07 M	Miles	1100	Sedimentation/Siltation	3110	Road Construction	2019			
CAR30412 3	Central Coast	R	Rivers/Streams	Bean Creek	30412041	8,907.07 M	Miles	1100	Sedimentation/Siltation	3215	Disturbed Sites (Land Develop.)	2019			
CAR30412 3	Central Coast	R	Rivers/Streams	Bean Creek	30412041	8,907.07 M	Miles	1100	Sedimentation/Siltation	5000	Resource Extraction	2019			
CAR30412 3	Central Coast	R	Rivers/Streams	Bean Creek	30412041	8,907.07 M	Miles	1100	Sedimentation/Siltation	7820	Erosion/Siltation	2019			
CAR30412 3	Central Coast	R	Rivers/Streams	Bean Creek	30412041	8,907.07 M	Miles	1100	Sedimentation/Siltation	9100	Nonpoint Source	2019			
CAR30412 3	Central Coast	R	Rivers/Streams	Bear Creek(Santa Cruz County)	30412030	6,315.31 M	Miles	1100	Sedimentation/Siltation	2000	Silviculture	2019			
CAR30412 3	Central Coast	R	Rivers/Streams	Bear Creek(Santa Cruz County)	30412030	6,315.31 M	Miles	1100	Sedimentation/Siltation	3110	Road Construction	2019			
CAR30412 3	Central Coast	R	Rivers/Streams	Bear Creek(Santa Cruz County)	30412030	6,315.31 M	Miles	1100	Sedimentation/Siltation	3215	Disturbed Sites (Land Develop.)	2019			
CAR30412 3	Central Coast	R	Rivers/Streams	Bear Creek(Santa Cruz County)	30412030	6,315.31 M	Miles	1100	Sedimentation/Siltation	7820	Erosion/Siltation	2019			
CAR30412 3	Central Coast	R	Rivers/Streams	Bear Creek(Santa Cruz County)	30412030	6,315.31 M	Miles	1100	Sedimentation/Siltation	9100	Nonpoint Source	2019			
CAR30412 3	Central Coast	R	Rivers/Streams	Boulder Creek	30412020	7,559.58 M	Miles	1100	Sedimentation/Siltation	1300	Specialty Crop Production	2019			
CAR30412 3	Central Coast	R	Rivers/Streams	Boulder Creek	30412020	7,559.58 M	Miles	1100	Sedimentation/Siltation	2000	Silviculture	2019			

WBID	REGION NUMBER	REGION NAME	WATER BODY TYPE ABBR	WATER BODY TYPE	WATER BODY NAME	CALWATER WATERSHED	ESTIMATED SIZE AFFECTED	UNIT ABBR	UNIT	POLLUTANT CODE	POLLUTANT	SOURCE CODE	POTENTIAL SOURCES	PROPOSED TMDL COMPLETION	COMMENTS
CAR30412 3	Central Coast	R	Rivers/Streams	Boulder Creek	30412020	7.55958 M	Miles	1100	Sedimentation/Siltation	3110	Road Construction	2019			
CAR30412 3	Central Coast	R	Rivers/Streams	Boulder Creek	30412020	7.55958 M	Miles	1100	Sedimentation/Siltation	3215	Disturbed Sites (Land Develop.)	2019			
CAR30412 3	Central Coast	R	Rivers/Streams	Boulder Creek	30412020	7.55958 M	Miles	1100	Sedimentation/Siltation	7820	Erosion/Siltation	2019			
CAR30412 3	Central Coast	R	Rivers/Streams	Boulder Creek	30412020	7.55958 M	Miles	1100	Sedimentation/Siltation	9100	Nonpoint Source	2019			
CAR30412 3	Central Coast	R	Rivers/Streams	Branciforte Creek	30412051	5.78 M	Miles	1100	Sedimentation/Siltation	2000	Silviculture	2019			
CAR30412 3	Central Coast	R	Rivers/Streams	Branciforte Creek	30412051	5.78 M	Miles	1100	Sedimentation/Siltation	3110	Road Construction	2019			
CAR30412 3	Central Coast	R	Rivers/Streams	Branciforte Creek	30412051	5.78 M	Miles	1100	Sedimentation/Siltation	9100	Nonpoint Source	2019			
CAR31300 3	Central Coast	R	Rivers/Streams	Casmalia Canyon Creek	31300040	4.96262 M	Miles	1100	Sedimentation/Siltation	9000	Source Unknown	2019			
CAR30412 3	Central Coast	R	Rivers/Streams	Fall Creek	30412022	5.07242 M	Miles	1100	Sedimentation/Siltation	3110	Road Construction	2019			
CAR30412 3	Central Coast	R	Rivers/Streams	Fall Creek	30412022	5.07242 M	Miles	1100	Sedimentation/Siltation	7550	Habitat Modification	2019			
CAR30412 3	Central Coast	R	Rivers/Streams	Fall Creek	30412022	5.07242 M	Miles	1100	Sedimentation/Siltation	7820	Erosion/Siltation	2019			
CAR30412 3	Central Coast	R	Rivers/Streams	Fall Creek	30412022	5.07242 M	Miles	1100	Sedimentation/Siltation	9100	Nonpoint Source	2019			
CAR30412 3	Central Coast	R	Rivers/Streams	Kings Creek	30412011	4.36837 M	Miles	1100	Sedimentation/Siltation	2000	Silviculture	2019			
CAR30412 3	Central Coast	R	Rivers/Streams	Kings Creek	30412011	4.36837 M	Miles	1100	Sedimentation/Siltation	3110	Road Construction	2019			
CAR30412 3	Central Coast	R	Rivers/Streams	Kings Creek	30412011	4.36837 M	Miles	1100	Sedimentation/Siltation	3215	Disturbed Sites (Land Develop.)	2019			
CAR30412 3	Central Coast	R	Rivers/Streams	Kings Creek	30412011	4.36837 M	Miles	1100	Sedimentation/Siltation	7820	Erosion/Siltation	2019			
CAR30412 3	Central Coast	R	Rivers/Streams	Kings Creek	30412011	4.36837 M	Miles	1100	Sedimentation/Siltation	9100	Nonpoint Source	2019			
CAR30412 3	Central Coast	R	Rivers/Streams	Love Creek	30412021	3.78816 M	Miles	1100	Sedimentation/Siltation	1000	Agriculture	2019			
CAR30412 3	Central Coast	R	Rivers/Streams	Love Creek	30412021	3.78816 M	Miles	1100	Sedimentation/Siltation	2000	Silviculture	2019			
CAR30412 3	Central Coast	R	Rivers/Streams	Love Creek	30412021	3.78816 M	Miles	1100	Sedimentation/Siltation	3110	Road Construction	2019			
CAR30412 3	Central Coast	R	Rivers/Streams	Love Creek	30412021	3.78816 M	Miles	1100	Sedimentation/Siltation	3215	Disturbed Sites (Land Develop.)	2019			
CAR30412 3	Central Coast	R	Rivers/Streams	Love Creek	30412021	3.78816 M	Miles	1100	Sedimentation/Siltation	7820	Erosion/Siltation	2019			
CAR30412 3	Central Coast	R	Rivers/Streams	Love Creek	30412021	3.78816 M	Miles	1100	Sedimentation/Siltation	9100	Nonpoint Source	2019			
CAR30412 3	Central Coast	R	Rivers/Streams	Mountain Charlie Gulch	30412040	3.92844 M	Miles	1100	Sedimentation/Siltation	2000	Silviculture	2019			
CAR30412 3	Central Coast	R	Rivers/Streams	Mountain Charlie Gulch	30412040	3.92844 M	Miles	1100	Sedimentation/Siltation	3110	Road Construction	2019			
CAR30412 3	Central Coast	R	Rivers/Streams	Mountain Charlie Gulch	30412040	3.92844 M	Miles	1100	Sedimentation/Siltation	7820	Erosion/Siltation	2019			
CAR30412 3	Central Coast	R	Rivers/Streams	Mountain Charlie Gulch	30412040	3.92844 M	Miles	1100	Sedimentation/Siltation	9100	Nonpoint Source	2019			
CAR30412 3	Central Coast	R	Rivers/Streams	Newell Creek (Upper)	30412031	3.50199 M	Miles	1100	Sedimentation/Siltation	1000	Agriculture	2019			
CAR30412 3	Central Coast	R	Rivers/Streams	Newell Creek (Upper)	30412031	3.50199 M	Miles	1100	Sedimentation/Siltation	2000	Silviculture	2019			
CAR30412 3	Central Coast	R	Rivers/Streams	Newell Creek (Upper)	30412031	3.50199 M	Miles	1100	Sedimentation/Siltation	3110	Road Construction	2019			
CAR30412 3	Central Coast	R	Rivers/Streams	Newell Creek (Upper)	30412031	3.50199 M	Miles	1100	Sedimentation/Siltation	3215	Disturbed Sites (Land Develop.)	2019			
CAR30412 3	Central Coast	R	Rivers/Streams	Newell Creek (Upper)	30412031	3.50199 M	Miles	1100	Sedimentation/Siltation	7810	Channel Erosion	2019			
CAR30412 3	Central Coast	R	Rivers/Streams	Newell Creek (Upper)	30412031	3.50199 M	Miles	1100	Sedimentation/Siltation	7820	Erosion/Siltation	2019			
CAR30412 3	Central Coast	R	Rivers/Streams	Newell Creek (Upper)	30412031	3.50199 M	Miles	1100	Sedimentation/Siltation	9100	Nonpoint Source	2019			
CAR40422 4	Los Angeles	R	Rivers/Streams	Las Virgenes Creek	40422010	11.62 M	Miles	1100	Sedimentation/Siltation	9000	Source Unknown	2019			
CAR40421 4	Los Angeles	R	Rivers/Streams	Malibu Creek	40421000	10.85 M	Miles	1100	Sedimentation/Siltation	9000	Source Unknown	2019			
CAR40424 4	Los Angeles	R	Rivers/Streams	Medea Creek Reach 1 (Lake to Confl. with Lindero)	40424000	2.57 M	Miles	1100	Sedimentation/Siltation	9000	Source Unknown	2019			
CAR40312 4	Los Angeles	R	Rivers/Streams	Calleguas Creek Reach 2 (estuary to Potrero Rd was Calleguas Creek Reaches 1 and 2 on 1998 303d list)	40312000	4.31213 M	Miles	1100	Sedimentation/Siltation	1000	Agriculture	2005	For 2006, sedimentation/siltation was moved by USEPA from the being addressed list back to the 303(d) list pending completion and USEPA approval of a TMDL.		
CAR40312 4	Los Angeles	R	Rivers/Streams	Calleguas Creek Reach 2 (estuary to Potrero Rd was Calleguas Creek Reaches 1 and 2 on 1998 303d list)	40312000	4.31213 M	Miles	1100	Sedimentation/Siltation	8600	Natural Sources	2005	For 2006, sedimentation/siltation was moved by USEPA from the being addressed list back to the 303(d) list pending completion and USEPA approval of a TMDL.		
CAR40312 4	Los Angeles	R	Rivers/Streams	Calleguas Creek Reach 3 (Potrero Road upstream to confluence with Conejo Creek on 1998 303d list)	40312000	3.46697 M	Miles	1100	Sedimentation/Siltation	1000	Agriculture	2005	For 2006, sedimentation/siltation was moved by USEPA from the being addressed list back to the 303(d) list pending completion and USEPA approval of a TMDL.		
CAR40312 4	Los Angeles	R	Rivers/Streams	Calleguas Creek Reach 3 (Potrero Road upstream to confluence with Conejo Creek on 1998 303d list)	40312000	3.46697 M	Miles	1100	Sedimentation/Siltation	8600	Natural Sources	2005	For 2006, sedimentation/siltation was moved by USEPA from the being addressed list back to the 303(d) list pending completion and USEPA approval of a TMDL.		
CAR40311 4	Los Angeles	R	Rivers/Streams	Calleguas Creek Reach 4 (was Revolon Slough Main Branch: Mugu Lagoon to Central Avenue on 1998 303d list)	40311000	7.18751 M	Miles	1100	Sedimentation/Siltation	1000	Agriculture	2005	For 2006, sedimentation/siltation was moved by USEPA from the being addressed list back to the 303(d) list pending completion and USEPA approval of a TMDL.		
CAR40311 4	Los Angeles	R	Rivers/Streams	Calleguas Creek Reach 4 (was Revolon Slough Main Branch: Mugu Lagoon to Central Avenue on 1998 303d list)	40311000	7.18751 M	Miles	1100	Sedimentation/Siltation	8600	Natural Sources	2005	For 2006, sedimentation/siltation was moved by USEPA from the being addressed list back to the 303(d) list pending completion and USEPA approval of a TMDL.		
CAR40361 4	Los Angeles	R	Rivers/Streams	Calleguas Creek Reach 5 (was Beardsley Channel on 1998 303d list)	40311000	4.34088 M	Miles	1100	Sedimentation/Siltation	1000	Agriculture	2005	For 2006, sedimentation/siltation was moved by USEPA from the being addressed list back to the 303(d) list pending completion and USEPA approval of a TMDL.		
CAR40361 4	Los Angeles	R	Rivers/Streams	Calleguas Creek Reach 5 (was Beardsley Channel on 1998 303d list)	40311000	4.34088 M	Miles	1100	Sedimentation/Siltation	8600	Natural Sources	2005	For 2006, sedimentation/siltation was moved by USEPA from the being addressed list back to the 303(d) list pending completion and USEPA approval of a TMDL.		
CAR40362 4	Los Angeles	R	Rivers/Streams	Calleguas Creek Reach 6 (was Arroyo Las Posas Reaches 1 and 2 on 1998 303d list)	40362000	15.2966 M	Miles	1100	Sedimentation/Siltation	1000	Agriculture	2005	For 2006, sedimentation/siltation was moved by USEPA from the being addressed list back to the 303(d) list pending completion and USEPA approval of a TMDL.		
CAR40362 4	Los Angeles	R	Rivers/Streams	Calleguas Creek Reach 6 (was Arroyo Las Posas Reaches 1 and 2 on 1998 303d list)	40362000	15.2966 M	Miles	1100	Sedimentation/Siltation	8600	Natural Sources	2005	For 2006, sedimentation/siltation was moved by USEPA from the being addressed list back to the 303(d) list pending completion and USEPA approval of a TMDL.		
CAR40362 4	Los Angeles	R	Rivers/Streams	Calleguas Creek Reach 7 (was Arroyo Simi Reaches 1 and 2 on 1998 303d list)	40367000	13.9129 M	Miles	1100	Sedimentation/Siltation	1000	Agriculture	2005	For 2006, sedimentation/siltation was moved by USEPA from the being addressed list back to the 303(d) list pending completion and USEPA approval of a TMDL.		
CAR40362 4	Los Angeles	R	Rivers/Streams	Calleguas Creek Reach 7 (was Arroyo Simi Reaches 1 and 2 on 1998 303d list)	40367000	13.9129 M	Miles	1100	Sedimentation/Siltation	8600	Natural Sources	2005	For 2006, sedimentation/siltation was moved by USEPA from the being addressed list back to the 303(d) list pending completion and USEPA approval of a TMDL.		
CAR40367 4	Los Angeles	R	Rivers/Streams	Calleguas Creek Reach 8 (was Tapo Canyon Reach 1)	40366000	7.18869 M	Miles	1100	Sedimentation/Siltation	9100	Nonpoint Source	2005	For 2006, sedimentation/siltation was moved by USEPA from the being addressed list back to the 303(d) list pending completion and USEPA approval of a TMDL.		
CAR40364 4	Los Angeles	R	Rivers/Streams	Calleguas Creek Reach 11 (Arroyo Santa Rosa was part of Conejo Creek Reach 3 on 1998 303d list)	40365000	8.68888 M	Miles	1100	Sedimentation/Siltation	1000	Agriculture	2005	For 2006, sedimentation/siltation was moved by USEPA from the being addressed list back to the 303(d) list pending completion and USEPA approval of a TMDL.		
CAR40364 4	Los Angeles	R	Rivers/Streams	Calleguas Creek Reach 11 (Arroyo Santa Rosa was part of Conejo Creek Reach 3 on 1998 303d list)	40365000	8.68888 M	Miles	1100	Sedimentation/Siltation	8600	Natural Sources	2005	For 2006, sedimentation/siltation was moved by USEPA from the being addressed list back to the 303(d) list pending completion and USEPA approval of a TMDL.		
CAR40423 4	Los Angeles	R	Rivers/Streams	Medea Creek Reach 2 (Abv Confl. with Lindero)	40423000	5.41 M	Miles	1100	Sedimentation/Siltation	9000	Source Unknown	2019			
CAR40424 4	Los Angeles	R	Rivers/Streams	Triunfo Canyon Creek Reach 1	40424000	2.51 M	Miles	1100	Sedimentation/Siltation	9000	Source Unknown	2019			
CAR40424 4	Los Angeles	R	Rivers/Streams	Triunfo Canyon Creek Reach 2	40424000	3.32 M	Miles	1100	Sedimentation/Siltation	9000	Source Unknown	2019			
CAR52641 5	Central Valley	R	Rivers/Streams	Fall River (Pit)	52641031	8.61219 M	Miles	1100	Sedimentation/Siltation	2105	Historical Land Management Activities	2016			
CAR51732 5	Central Valley	R	Rivers/Streams	Humbug Creek	51732030	2.20272 M	Miles	1100	Sedimentation/Siltation	5000	Resource Extraction	2012			The sedimentation is accumulated sand size sediment in the upper Fall River. The historic land management activities include logging, grazing, channelization, roads, and railroads. All resource extraction sources are abandoned mine
CAR55911 5	Central Valley	R	Rivers/Streams	Panoche Creek (Silver Creek to Belmont Avenue)	55112000	17.6357 M	Miles	1100	Sedimentation/Siltation	1000	Agriculture	2007			
CAR55911 5	Central Valley	R	Rivers/Streams	Panoche Creek (Silver Creek to Belmont Avenue)	55112000	17.6357 M	Miles	1100	Sedimentation/Siltation	1935	Agriculture-grazing	2007			

WBID	REGION NUMBER	REGION NAME	WATER BODY TYPE ABBR	WATER BODY TYPE	WATER BODY NAME	CALWATER WATERSHED	ESTIMATED SIZE AFFECTED	UNIT ABBR	UNIT	POLLUTANT CODE	POLLUTANT	SOURCE CODE	POTENTIAL SOURCES	PROPOSED TMDL COMPLETION	COMMENTS
CAR559115		Central Valley	R	Rivers/Streams	Panache Creek (Silver Creek to Belmont Avenue)	55112000	17.6357 M	Miles	1100		Sedimentation/Siltation	3100	Highway/Road/Bridge Construction	2007	
CAL630306		Lahontan	L	Lakes/Reservoirs	Bridgeport Reservoir	63030050	2614.34 A	Acres	1100		Sedimentation/Siltation	1350	Grazing-Related Sources	2006	
CAL630306		Lahontan	L	Lakes/Reservoirs	Bridgeport Reservoir	63030050	2614.34 A	Acres	1100		Sedimentation/Siltation	7700	Streambank Modification/Destabilization	2006	
CAL630306		Lahontan	L	Lakes/Reservoirs	Bridgeport Reservoir	63030050	2614.34 A	Acres	1100		Sedimentation/Siltation	7820	Erosion/Siltation	2006	
CAL630306		Lahontan	L	Lakes/Reservoirs	Bridgeport Reservoir	63030050	2614.34 A	Acres	1100		Sedimentation/Siltation	8540	Sediment Resuspension	2006	
CAL634306		Lahontan	L	Lakes/Reservoirs	Tahoe, Lake	63430010	85364.1 A	Acres	1100		Sedimentation/Siltation	1050	Grazing-Related Sources	2007	
CAL634306		Lahontan	L	Lakes/Reservoirs	Tahoe, Lake	63430010	85364.1 A	Acres	1100		Sedimentation/Siltation	2000	Silviculture	2007	
CAL634306		Lahontan	L	Lakes/Reservoirs	Tahoe, Lake	63430010	85364.1 A	Acres	1100		Sedimentation/Siltation	3100	Highway/Road/Bridge Construction	2007	
CAL634306		Lahontan	L	Lakes/Reservoirs	Tahoe, Lake	63430010	85364.1 A	Acres	1100		Sedimentation/Siltation	3200	Land Development	2007	
CAL634306		Lahontan	L	Lakes/Reservoirs	Tahoe, Lake	63430010	85364.1 A	Acres	1100		Sedimentation/Siltation	4000	Urban Runoff/Storm Sewers	2007	
CAL634306		Lahontan	L	Lakes/Reservoirs	Tahoe, Lake	63430010	85364.1 A	Acres	1100		Sedimentation/Siltation	4300	Other Urban Runoff	2007	
CAL634306		Lahontan	L	Lakes/Reservoirs	Tahoe, Lake	63430010	85364.1 A	Acres	1100		Sedimentation/Siltation	4500	Highway/Road/Bridge Runoff	2007	
CAL634306		Lahontan	L	Lakes/Reservoirs	Tahoe, Lake	63430010	85364.1 A	Acres	1100		Sedimentation/Siltation	4600	Urban Runoff-Erosion and Sedimentation	2007	
CAL634306		Lahontan	L	Lakes/Reservoirs	Tahoe, Lake	63430010	85364.1 A	Acres	1100		Sedimentation/Siltation	7000	Hydromodification	2007	
CAL634306		Lahontan	L	Lakes/Reservoirs	Tahoe, Lake	63430010	85364.1 A	Acres	1100		Sedimentation/Siltation	7100	Channelization	2007	
CAL634306		Lahontan	L	Lakes/Reservoirs	Tahoe, Lake	63430010	85364.1 A	Acres	1100		Sedimentation/Siltation	7600	Removal of Riparian Vegetation	2007	
CAL634306		Lahontan	L	Lakes/Reservoirs	Tahoe, Lake	63430010	85364.1 A	Acres	1100		Sedimentation/Siltation	7700	Streambank Modification/Destabilization	2007	
CAL634306		Lahontan	L	Lakes/Reservoirs	Tahoe, Lake	63430010	85364.1 A	Acres	1100		Sedimentation/Siltation	7810	Channel Erosion	2007	
CAL634306		Lahontan	L	Lakes/Reservoirs	Tahoe, Lake	63430010	85364.1 A	Acres	1100		Sedimentation/Siltation	7820	Erosion/Siltation	2007	
CAL634306		Lahontan	L	Lakes/Reservoirs	Tahoe, Lake	63430010	85364.1 A	Acres	1100		Sedimentation/Siltation	8540	Atmospheric Deposition	2007	
CAL634306		Lahontan	L	Lakes/Reservoirs	Tahoe, Lake	63430010	85364.1 A	Acres	1100		Sedimentation/Siltation	8600	Sediment Resuspension	2007	
CAL634306		Lahontan	L	Lakes/Reservoirs	Tahoe, Lake	63430010	85364.1 A	Acres	1100		Sedimentation/Siltation	8600	Natural Sources	2007	
CAL634306		Lahontan	L	Lakes/Reservoirs	Tahoe, Lake	63430010	85364.1 A	Acres	1100		Sedimentation/Siltation	8700	Recreational and Tourism Activities (non-boating)	2007	
CAL634306		Lahontan	L	Lakes/Reservoirs	Tahoe, Lake	63430010	85364.1 A	Acres	1100		Sedimentation/Siltation	9100	Nonpoint Source	2007	
CAR634206		Lahontan	R	Rivers/Streams	Blackwood Creek	63420021	5.87001 M	Miles	1100		Sedimentation/Siltation	1500	Range Grazing-Riparian and/or Upland	2008	Creek affected by past gravel quarry operations and other watershed disturbance including grazing and timber harv
CAR634206		Lahontan	R	Rivers/Streams	Blackwood Creek	63420021	5.87001 M	Miles	1100		Sedimentation/Siltation	2000	Silviculture	2008	
CAR634206		Lahontan	R	Rivers/Streams	Blackwood Creek	63420021	5.87001 M	Miles	1100		Sedimentation/Siltation	3000	Construction/Land Development	2008	Creek affected by past gravel quarry operations and other watershed disturbance including grazing and timber harv
CAR634206		Lahontan	R	Rivers/Streams	Blackwood Creek	63420021	5.87001 M	Miles	1100		Sedimentation/Siltation	4501	Surface Runoff	2008	
CAR634206		Lahontan	R	Rivers/Streams	Blackwood Creek	63420021	5.87001 M	Miles	1100		Sedimentation/Siltation	5000	Resource Extraction	2008	Creek affected by past gravel quarry operations and other watershed disturbance including grazing and timber harv
CAR634206		Lahontan	R	Rivers/Streams	Blackwood Creek	63420021	5.87001 M	Miles	1100		Sedimentation/Siltation	7000	Hydromodification	2008	Creek affected by past gravel quarry operations and other watershed disturbance including grazing and timber harv
CAR634206		Lahontan	R	Rivers/Streams	Blackwood Creek	63420021	5.87001 M	Miles	1100		Sedimentation/Siltation	7700	Streambank Modification/Destabilization	2008	Creek affected by past gravel quarry operations and other watershed disturbance including grazing and timber harv
CAR634206		Lahontan	R	Rivers/Streams	Blackwood Creek	63420021	5.87001 M	Miles	1100		Sedimentation/Siltation	7820	Erosion/Siltation	2008	Creek affected by past gravel quarry operations and other watershed disturbance including grazing and timber harv
CAR634206		Lahontan	R	Rivers/Streams	Blackwood Creek	63420021	5.87001 M	Miles	1100		Sedimentation/Siltation	8100	Atmospheric Deposition	2008	Creek affected by past gravel quarry operations and other watershed disturbance including grazing and timber harv
CAR634206		Lahontan	R	Rivers/Streams	Blackwood Creek	63420021	5.87001 M	Miles	1100		Sedimentation/Siltation	8600	Natural Sources	2008	Creek affected by past gravel quarry operations and other watershed disturbance including grazing and timber harv
CAR634206		Lahontan	R	Rivers/Streams	Blackwood Creek	63420021	5.87001 M	Miles	1100		Sedimentation/Siltation	8700	Recreational and Tourism Activities (non-boating)	2008	Creek affected by past gravel quarry operations and other watershed disturbance including grazing and timber harv
CAR634206		Lahontan	R	Rivers/Streams	Blackwood Creek	63420021	5.87001 M	Miles	1100		Sedimentation/Siltation	9100	Nonpoint Source	2008	Creek affected by past gravel quarry operations and other watershed disturbance including grazing and timber harv
CAR635206		Lahontan	R	Rivers/Streams	Bronco Creek	63520053	1.34403 M	Miles	1100		Sedimentation/Siltation	2000	Silviculture	2006	Watershed disturbance in naturally highly erosive watershe
CAR635206		Lahontan	R	Rivers/Streams	Bronco Creek	63520053	1.34403 M	Miles	1100		Sedimentation/Siltation	8600	Natural Sources	2006	Watershed disturbance in naturally highly erosive watershe
CAR635206		Lahontan	R	Rivers/Streams	Bronco Creek	63520053	1.34403 M	Miles	1100		Sedimentation/Siltation	9100	Nonpoint Source	2006	Watershed disturbance in naturally highly erosive watershe
CAR630406		Lahontan	R	Rivers/Streams	Clearwater Creek	63040051	12.4874 M	Miles	1100		Sedimentation/Siltation	1500	Range Grazing-Riparian and/or Upland	2006	Listed on basis of limited information; additional monitoring may support delisti
CAR630406		Lahontan	R	Rivers/Streams	Clearwater Creek	63040051	12.4874 M	Miles	1100		Sedimentation/Siltation	3000	Construction/Land Development	2006	Listed on basis of limited information; additional monitoring may support delisti
CAR630406		Lahontan	R	Rivers/Streams	Clearwater Creek	63040051	12.4874 M	Miles	1100		Sedimentation/Siltation	4501	Highway Maintenance and Runoff	2006	Listed on basis of limited information; additional monitoring may support delisti
CAR630106		Lahontan	R	Rivers/Streams	East Walker River, below Bridgeport Reservo	63030050	8.00973 M	Miles	1100		Sedimentation/Siltation	1350	Grazing-Related Sources	2019	
CAR630106		Lahontan	R	Rivers/Streams	East Walker River, below Bridgeport Reservo	63030050	8.00973 M	Miles	1100		Sedimentation/Siltation	4500	Highway/Road/Bridge Runoff	2019	
CAR630106		Lahontan	R	Rivers/Streams	East Walker River, below Bridgeport Reservo	63030050	8.00973 M	Miles	1100		Sedimentation/Siltation	4600	Urban Runoff-Erosion and Sedimentation	2019	
CAR630106		Lahontan	R	Rivers/Streams	East Walker River, below Bridgeport Reservo	63030050	8.00973 M	Miles	1100		Sedimentation/Siltation	7350	Upstream Impoundment	2019	
CAR630106		Lahontan	R	Rivers/Streams	East Walker River, below Bridgeport Reservo	63030050	8.00973 M	Miles	1100		Sedimentation/Siltation	7820	Erosion/Siltation	2019	
CAR635206		Lahontan	R	Rivers/Streams	Gray Creek (Nevada County)	63520052	2.8033 M	Miles	1100		Sedimentation/Siltation	2000	Silviculture	2006	Sediment from disturbance of naturally highly erosive watershe
CAR635206		Lahontan	R	Rivers/Streams	Gray Creek (Nevada County)	63520052	2.8033 M	Miles	1100		Sedimentation/Siltation	8600	Natural Sources	2006	Sediment from disturbance of naturally highly erosive watershe
CAR635206		Lahontan	R	Rivers/Streams	Gray Creek (Nevada County)	63520052	2.8033 M	Miles	1100		Sedimentation/Siltation	9100	Nonpoint Source	2006	Sediment from disturbance of naturally highly erosive watershe
CAR634106		Lahontan	R	Rivers/Streams	Heavenly Valley Creek (USFS boundary to Trout Creek)	63410031	1.44732 M	Miles	1100		Sedimentation/Siltation	3000	Construction/Land Development	2019	
CAR634106		Lahontan	R	Rivers/Streams	Heavenly Valley Creek (USFS boundary to Trout Creek)	63410031	1.44732 M	Miles	1100		Sedimentation/Siltation	3200	Land Development	2019	
CAR634106		Lahontan	R	Rivers/Streams	Heavenly Valley Creek (USFS boundary to Trout Creek)	63410031	1.44732 M	Miles	1100		Sedimentation/Siltation	7000	Hydromodification	2019	
CAR634106		Lahontan	R	Rivers/Streams	Heavenly Valley Creek (USFS boundary to Trout Creek)	63410031	1.44732 M	Miles	1100		Sedimentation/Siltation	7550	Habitat Modification	2019	
CAR634106		Lahontan	R	Rivers/Streams	Heavenly Valley Creek (USFS boundary to Trout Creek)	63410031	1.44732 M	Miles	1100		Sedimentation/Siltation	8700	Recreational and Tourism Activities (non-boating)	2019	
CAR634106		Lahontan	R	Rivers/Streams	Heavenly Valley Creek (USFS boundary to Trout Creek)	63410031	1.44732 M	Miles	1100		Sedimentation/Siltation	9100	Nonpoint Source	2019	
CAR630306		Lahontan	R	Rivers/Streams	Hot Springs Canyon Creek	63030042	2.8612 M	Miles	1100		Sedimentation/Siltation	1500	Range Grazing-Riparian and/or Upland	2008	Listed on basis of limited data; further monitoring may support delistr
CAR635206		Lahontan	R	Rivers/Streams	Squaw Creek	63520011	5.8 M	Miles	1100		Sedimentation/Siltation	3000	Construction/Land Development	2006	
CAR635206		Lahontan	R	Rivers/Streams	Squaw Creek	63520011	5.8 M	Miles	1100		Sedimentation/Siltation	4300	Other Urban Runoff	2006	
CAR635206		Lahontan	R	Rivers/Streams	Squaw Creek	63520011	5.8 M	Miles	1100		Sedimentation/Siltation	7000	Hydromodification	2006	
CAR635206		Lahontan	R	Rivers/Streams	Squaw Creek	63520011	5.8 M	Miles	1100		Sedimentation/Siltation	7800	Drainage/Filling Of Wetlands	2006	
CAR635206		Lahontan	R	Rivers/Streams	Squaw Creek	63520011	5.8 M	Miles	1100		Sedimentation/Siltation	8300	Highway Maintenance and Runoff	2006	
CAR635206		Lahontan	R	Rivers/Streams	Squaw Creek	63520011	5.8 M	Miles	1100		Sedimentation/Siltation	8600	Natural Sources	2006	
CAR635206		Lahontan	R	Rivers/Streams	Squaw Creek	63520011	5.8 M	Miles	1100		Sedimentation/Siltation	8700	Recreational and Tourism Activities (non-boating)	2006	
CAR635206		Lahontan	R	Rivers/Streams	Squaw Creek	63520011	5.8 M	Miles	1100		Sedimentation/Siltation	9100	Nonpoint Source	2006	
CAR635106		Lahontan	R	Rivers/Streams	Truckee River	63510010	39.1307 M	Miles	1100		Sedimentation/Siltation	1500	Range Grazing-Riparian and/or Upland	2006	Watershed disturbance including ski resorts, silvicultural activities, urban development, reservoir construction and management; highly erosive subwatersh
CAR635106		Lahontan	R	Rivers/Streams	Truckee River	63510010	39.1307 M	Miles	1100		Sedimentation/Siltation	2000	Silviculture	2006	Watershed disturbance including ski resorts, silvicultural activities, urban development, reservoir construction and management; highly erosive subwatersh
CAR635106		Lahontan	R	Rivers/Streams	Truckee River	63510010	39.1307 M	Miles	1100		Sedimentation/Siltation	3000	Construction/Land Development	2006	Watershed disturbance including ski resorts, silvicultural activities, urban development, reservoir construction and management; highly erosive subwatersh
CAR635106		Lahontan	R	Rivers/Streams	Truckee River	63510010	39.1307 M	Miles	1100		Sedimentation/Siltation	3100	Highway/Road/Bridge Construction	2006	Watershed disturbance including ski resorts, silvicultural activities, urban development, reservoir construction and management; highly erosive subwatersh
CAR635106		Lahontan	R	Rivers/Streams	Truckee River	63510010	39.1307 M	Miles	1100		Sedimentation/Siltation	7700	Streambank Modification/Destabilization	2006	Watershed disturbance including ski resorts, silvicultural activities, urban development, reservoir construction and management; highly erosive subwatersh
CAR635106		Lahontan	R	Rivers/Streams	Truckee River	63510010	39.1307 M	Miles	1100		Sedimentation/Siltation	7810	Channel Erosion	2006	Watershed disturbance including ski resorts, silvicultural activities, urban development, reservoir construction and management; highly erosive subwatersh
CAR635106		Lahontan	R	Rivers/Streams	Truckee River	63510010	39.1307 M	Miles	1100		Sedimentation/Siltation	7920	Nonpoint Source	2006	Watershed disturbance including ski resorts, silvicultural activities, urban development, reservoir construction and management; highly erosive subwatersh
CAR635106		Lahontan	R	Rivers/Streams	Truckee River	63510010	39.1307 M	Miles	1100		Sedimentation/Siltation	8600	Natural Sources	2006	Watershed disturbance including ski resorts, silvicultural activities, urban development, reservoir construction and management; highly erosive subwatersh
CAR635106		Lahontan	R	Rivers/Streams	Truckee River	63510010	39.1307 M	Miles	1100		Sedimentation/Siltation	8700	Recreational and Tourism Activities (non-boating)		

WBID	REGION NUMBER	REGION NAME	WATER BODY TYPE ABBR	WATER BODY TYPE	WATER BODY NAME	CALWATER WATERSHED	ESTIMATED SIZE AFFECTED	UNIT ABBR	UNIT	POLLUTANT CODE	POLLUTANT	SOURCE CODE	POTENTIAL SOURCES	PROPOSED TMDL COMPLETION	COMMENTS
CAR63420 6	Lahontan	R	Rivers/Streams	Ward Creek	63420020	5.675 M	Miles	1100	Sedimentation/Siltation	4500	Highway/Road/Bridge Runoff	2008			
CAR63420 6	Lahontan	R	Rivers/Streams	Ward Creek	63420020	5.675 M	Miles	1100	Sedimentation/Siltation	7810	Channel Erosion	2008			
CAR63420 6	Lahontan	R	Rivers/Streams	Ward Creek	63420020	5.675 M	Miles	1100	Sedimentation/Siltation	9100	Nonpoint Source	2008			
CAR63210 6	Lahontan	R	Rivers/Streams	Wolf Creek (Alpine County)	63210031	11.8207 M	Miles	1100	Sedimentation/Siltation	1500	Range Grazing-Riparian and/or Upland	2019			
CAR63210 6	Lahontan	R	Rivers/Streams	Wolf Creek (Alpine County)	63210031	11.8207 M	Miles	1100	Sedimentation/Siltation	2000	Silviculture	2019			
CAR63210 6	Lahontan	R	Rivers/Streams	Wolf Creek (Alpine County)	63210031	11.8207 M	Miles	1100	Sedimentation/Siltation	9100	Nonpoint Source	2019			
CAL8017118	Santa Ana	L	Lakes/Reservoirs	Big Bear Lake	80171000	2865.01 A	Acres	1100	Sedimentation/Siltation	3000	Construction/Land Development	2006			
CAL8017118	Santa Ana	L	Lakes/Reservoirs	Big Bear Lake	80171000	2865.01 A	Acres	1100	Sedimentation/Siltation	8710	Snow skiing activities	2006			
CAL8017118	Santa Ana	L	Lakes/Reservoirs	Big Bear Lake	80171000	2865.01 A	Acres	1100	Sedimentation/Siltation	9105	Unknown Nonpoint Source	2006			
CAR80171 8	Santa Ana	R	Rivers/Streams	Rathbone (Rathbun) Creek	80171000	4.68 M	Miles	1100	Sedimentation/Siltation	8710	Snow skiing activities	2006			
CAR80171 8	Santa Ana	R	Rivers/Streams	Rathbone (Rathbun) Creek	80171000	4.68 M	Miles	1100	Sedimentation/Siltation	9105	Unknown Nonpoint Source	2006			
CAE9043119	San Diego	E	Estuaries	Agua Hedionda Lagoon	90431000	6.83187 A	Acres	1100	Sedimentation/Siltation	9201	Nonpoint/Point Source	2019			
CAE9042119	San Diego	E	Estuaries	Buena Vista Lagoon	90421000	202.298 A	Acres	1100	Sedimentation/Siltation	9201	Nonpoint/Point Source	2019			
CAE9061019	San Diego	E	Estuaries	Los Peñasquitos Lagoon	90610000	468.918 A	Acres	1100	Sedimentation/Siltation	9201	Nonpoint/Point Source	2019			
CAE9046119	San Diego	E	Estuaries	San Elijo Lagoon	90461000	565.804 A	Acres	1100	Sedimentation/Siltation	9201	Nonpoint/Point Source	2019	Estimated size of impairment is 150 acres		

Post-Construction Water Balance Calculator

1	Post-Construction Water Balance Calculator									
2										
3	User may make changes from any cell that is orange or brown in color (similar to the cells to the immediate right). Cells in green are calculated for you.		(Step 1a) If you know the 85th percentile storm event for your location enter it in the box below		(Step 1b) If you can not answer 1a then select the county where the project is located (click on the cell to the right for drop-down): This will determine the average 85th percentile 24 hr. storm event for your site, which will appear under precipitation to left.		SACRAMENTO			
4					(Step 1c) If you would like a more precise value select the location closest to your site. If you do not recognize any of these locations, leave this drop-down menu at location. The average value for the County will be used.		SACRAMENTO FAA ARPT			
5	Project Information				Runoff Calculations					
6	Project Name:		Optional		(Step 2) Indicate the Soil Type (dropdown menu to right):		Group C Soils		Low infiltration. Sandy clay loam. Infiltration rate 0.05 to 0.15 inch/hr when wet.	
7	Waste Discharge Identification (WDID):		Optional		(Step 3) Indicate the existing dominant non-built land Use Type (dropdown menu to right):		Wood & Grass: <50% ground cover			
8	Date:		Optional		(Step 4) Indicate the proposed dominant non-built land Use Type (dropdown menu to right):		Lawn, Grass, or Pasture covering more than 75% of the open space			
9	Sub Drainage Area Name (from map):		Optional				Complete Either			
10	Runoff Curve Numbers						Sq Ft		Acres	
11	Existing Pervious Runoff Curve Number		82		(Step 5) Total Project Site Area:		5.00		5.00	
12	Proposed Development Pervious Runoff Curve Number		74		(Step 6) Sub-watershed Area:		5.00		5.00	
13	Design Storm				Percent of total project :		100%			
14	Based on the County you indicated above, we have included the 85 percentile average 24 hr event - P85 (in) ⁶ for your area.		0.62		in					
15	The Amount of rainfall needed for runoff to occur (Existing runoff curve number -P from existing RCN (in) ⁶)		0.44		In		(Step 7) Sub-watershed Conditions		Complete Either	
16	P used for calculations (in) (the greater of the above two criteria)		0.62		In		Sub-watershed Area (acres)		Calculated Acres	
17	^Available at www.cabmphandbooks.com				Existing Rooftop Impervious Coverage		0		0.00	
18					Existing Non-Rooftop Impervious Coverage		0		0.00	
19					Proposed Rooftop Impervious Coverage		0		0.00	
20					Proposed Non-Rooftop Impervious Coverage		0		0.00	
21					Credits		Acres		Square Feet	
22					Porous Pavement		0.00		0	
23					Tree Planting		0.00		0	
24					Downspout Disconnection		0.00		0	
25	Pre-Project Runoff Volume (cu ft)		247		Cu.Ft.					
26	Project-Related Runoff Volume Increase w/o credits (cu ft)		0		Cu.Ft.					
27					Impervious Area Disconnection		0.00		0	
28					Green Roof		0.00		0	
29					Stream Buffer		0.00		0	
30	Project-Related Volume Increase with Credits (cu ft)		0		Cu.Ft.		Vegetated Swales		0.00	
31					Subtotal		0.00		0	
32					Subtotal Runoff Volume Reduction Credit		0 Cu. Ft.			
33	You have achieved your minimum requirements				(Step 9) Impervious Volume Reduction Credits		Volume (cubic feet)			
34					Rain Barrels/Cisterns		0		Cu. Ft.	
35					Soil Quality		0		Cu. Ft.	
36					Subtotal Runoff Volume Reduction		0 Cu. Ft.			
37					Total Runoff Volume Reduction Credit		0		Cu. Ft.	
38										
39										

Porous Pavement Credit Worksheet

Please fill out a porous pavement credit worksheet for each project sub-watershed.

For the PROPOSED Development:

Proposed Porous Pavement	Runoff Reduction*	Fill in either Acres or SqFt		Equivalent Acres
		In SqFt.	In Acres	
Area of Brick without Grout on <u>less than 12 inches</u> of base with at least 20% void space over soil	0.45			0.00
Area of Brick without Grout on <u>more than 12 inches</u> of base with at least 20% void space over soil	0.90			0.00
Area of Cobbles <u>less than 12 inches</u> deep and over soil	0.30			0.00
Area of Cobbles <u>less than 12 inches</u> deep and over soil	0.60			0.00
Area of Reinforced Grass Pavement on <u>less than 12 inches</u> of base with at least 20% void space over soil	0.45			0.00
Area of Reinforced Grass Pavement on <u>at least 12 inches</u> of base with at least 20% void space over soil	0.90			0.00
Area of Porous Gravel Pavement on <u>less than 12 inches</u> of base with at least 20% void space over soil	0.38			0.00
Area of Porous Gravel Pavement on <u>at least 12 inches</u> of base with at least 20% void space over soil	0.75			0.00
Area of Poured Porous Concrete or Asphalt Pavement with <u>less than 4 inches</u> of gravel base (washed stone)	0.40			0.00
Area of Poured Porous Concrete or Asphalt Pavement with <u>4 to 8 inches</u> of gravel base (washed stone)	0.60			0.00
Area of Poured Porous Concrete or Asphalt Pavement with <u>8 to 12 inches</u> of gravel base (washed stone)	0.80			0.00
Area of Poured Porous Concrete or Asphalt Pavement with <u>12 or more</u> inches of gravel base (washed stone)	1.00			0.00

*=1-Rv**

[Return to Calculator](#)

**Using Site Design Techniques to meet Development Standards for Stormwater Quality (BASMAA 2003)

**NCDENR Stormwater BMP Manual (2007)

Tree Planting Credit Worksheet

Please fill out a tree canopy credit worksheet for each project sub-watershed.

Tree Canopy Credit Criteria	Number of Trees Planted	Credit (acres)
Number of proposed evergreen trees to be planted (credit = number of trees x 0.005)*	0	0.00
Number of proposed deciduous trees to be planted (credit = number of trees x 0.0025)*		0.00
	Square feet Under Canopy	
Square feet under an existing tree canopy, that will remain on the property, with an average diameter at 4.5 ft above grade (i.e., diameter at breast height or DBH) is LESS than 12 in diameter.		0.00
Square feet under an existing tree canopy that will remain on the property, with an average diameter at 4.5 ft above grade (i.e., diameter at breast height or DBH) is 12 in diameter or GREATER.		0.00
Please describe below how the project will ensure that these trees will be maintained.		

0

[Return to Calculator](#)

* credit amount based on credits from Stormwater Quality Design Manual for the Sacramento and South Placer Regions

Downspout Disconnection Credit Worksheet

Please fill out a downspout disconnection credit worksheet for each project subwatershed. If you answer yes to all questions, all rooftop area draining to each downspout will be subtracted from your proposed rooftop impervious coverage.

Downspout Disconnection Credit Criteria					
Do downspouts and any extensions extend at least six feet from a basement and two feet from a crawl space or concrete slab?				<input type="radio"/> Yes	<input checked="" type="radio"/> No
Is the area of rooftop connecting to each disconnected downspout 600 square feet or less?				<input type="radio"/> Yes	<input checked="" type="radio"/> No
Is the roof runoff from the design storm event fully contained in a raised bed or planter box or does it drain as sheet flow to a landscaped area large enough to contain the roof runoff from the design storm event?				<input type="radio"/> Yes	<input checked="" type="radio"/> No
The Stream Buffer and/or Vegetated Swale credits will not be taken in this sub-watershed area?				<input type="radio"/> Yes	<input checked="" type="radio"/> No
Percentage of existing	0.00	Acres	of rooftop surface has disconnected downspouts		
Percentage of the proposed	0.00	Acres	of rooftop surface has disconnected downspouts		
				50	
				Return to Calculator	

Impervious Area Disconnection Credit Worksheet

Please fill out an impervious area disconnection credit worksheet for each project sub-watershed. If you answer yes to all questions, all non-rooftop impervious surface area will be subtracted from your proposed non-rooftop impervious coverage.

Non-Rooftop Disconnection Credit Criteria	Response
Is the maximum contributing impervious flow path length less than 75 feet or, if equal or greater than 75 feet, is a storage device (e.g. French drain, bioretention area, gravel trench) implemented to achieve the required disconnection length?	<input checked="" type="radio"/> Yes <input type="radio"/> No
Is the impervious area to any one discharge location less than 5,000 square feet?	<input checked="" type="radio"/> Yes <input type="radio"/> No
The Stream Buffer credit will not be taken in this sub-watershed area?	<input checked="" type="radio"/> Yes <input type="radio"/> No

Percentage of existing	0.00 Acres non-rooftop surface area disconnected	
Percentage of the proposed	0.00 Acres non-rooftop surface area disconnected	70

[Return to Calculator](#)

Green Roof Credit Worksheet

Please fill out a greenroof credit worksheet for each project sub-watershed. If you answer yes to all questions, 70% of the greenroof area will be subtracted from your proposed rooftop impervious coverage.

Green Roof Credit Criteria		Response
Is the roof slope less than 15% or does it have a grid to hold the substrate in place until it forms a thick vegetation mat?		<input checked="" type="radio"/> Yes <input type="radio"/> No
Has a professional engineer assessed the necessary load reserves and designed a roof structure to meet state and local codes?		<input checked="" type="radio"/> Yes <input type="radio"/> No
Is the irrigation needed for plant establishment and/or to sustain the green roof during extended dry periods, is the source from stored, recycled, reclaimed, or reused water?		<input checked="" type="radio"/> Yes <input type="radio"/> No
Percentage of existing	0.0 0 Acres rooftop surface area in greenroof	
Percentage of the proposed	0.0 0 Acres rooftop surface area in greenroof	
		Return to Calculator

Stream Buffer Credit Worksheet

Please fill out a stream buffer credit worksheet for each project sub-watershed. If you answer yes to all questions, you may subtract all impervious surface draining to each stream buffer that has not been addressed using the Downspout and/or Impervious Area Disconnection credits.

Stream Buffer Credit Criteria				Response
Does runoff enter the floodprone width* or within 500 feet (whichever is larger) of a stream channel as sheet flow**?				<input type="radio"/> Yes <input checked="" type="radio"/> No
Is the contributing overland slope 5% or less, or if greater than 5%, is a level spreader used?				<input type="radio"/> Yes <input checked="" type="radio"/> No
Is the buffer area protected from vehicle or other traffic barriers to reduce compaction?				<input type="radio"/> Yes <input checked="" type="radio"/> No
Will the stream buffer be maintained in an ungraded and uncompacted condition and will the vegetation be maintained in a natural condition?				<input type="radio"/> Yes <input checked="" type="radio"/> No
Percentage of existing	0.00	Acres	impervious surface area draining into a stream buffer:	
Percentage of the proposed	0.00	Acres	impervious surface area that will drain into a stream buffer:	
Please describe below how the project will ensure that the buffer areas will remain in ungraded and uncompacted condition and that the vegetation will be maintained in a natural condition.				

[Return to Calculator](#)

* floodprone width is the width at twice the bankfull depth.

** the maximum contributing length shall be 75 feet for impervious area

Vegetated Swale Credit Worksheet

Please fill out a vegetated swale worksheet for each project subwatershed. If you answer yes to all questions, you may subtract all impervious surface draining to each stream buffer that has not been addressed using the Downspout Disconnection credit.

Vegetated Swale Credit Criteria

Have all vegetated swales been designed in accordance with Treatment Control BMP 30 (TC-30 - Vegetated Swale) from the California Stormwater BMP Handbook, New Development and Redevelopment (available at www.cabmphandbooks.com)?

<input type="radio"/> Yes	<input checked="" type="radio"/> No
---------------------------	-------------------------------------

Is the maximum flow velocity for runoff from the design storm event less than or equal to 1.0 foot per second?

<input type="radio"/> Yes	<input checked="" type="radio"/> No
---------------------------	-------------------------------------

Percentage of existing	0.00	Acres of impervious area draining to a vegetated swale	
Percentage of the proposed	0.00	Acres of impervious area draining to a vegetated swale	

[Return to Calculator](#)

Rain Barrel/Cistern Credit Worksheet

Please fill out a rain barrel/cistern worksheet for each project sub-watershed.

Rain Barrel/Cistern Credit Criteria	Response
Total number of rain barrel(s)/cisterns	
Average capacity of rain barrel(s)/cistern(s) (in gallons)	
Total capacity rain barrel(s)/cistern(s) (in cu ft) ¹	0

¹ accounts for 10% loss

[Return to Calculator](#)

Please fill out a soil quality worksheet for each project sub-watershed.

	Response
Will the landscaped area be lined with an impervious membrane?	
Will the soils used for landscaping meet the ideal bulk densities listed in Table 1 below? ¹	<input type="radio"/> Yes <input checked="" type="radio"/> No
If you answered yes to the question above, and you know the area-weighted bulk density within the top 12 inches for soils used for landscaping (in g/cm ³)*, fill in the cell to the right and skip to cell G11. If not select from the drop-down menu in G10.	1.3
If you answered yes to the question above, but you do not know the exact bulk density, which of the soil types in the drop down menu to the right best describes the top 12 inches for soils used for landscaping (in g/cm ³).	Sandy loams, loams
What is the average depth of your landscaped soil media meeting the above criteria (inches)?	12
What is the total area of the landscaped areas meeting the above criteria (in acres)?	2.97

[Return to Calculator](#)

Table 1

Sands, loamy sands	<1.6
Sandy loams, loams	<1.4
Sandy clay loams, loams, clay loams	<1.4
Silts, silt loams	<1.3
Silt loams, silty clay loams	<1.1
Sandy clays, silty clays, some clay loams (35-45% clay)	<1.1
Clays (>45% clay)	<1.1

Porosity (%) 50.94%

Mineral grains in many soils are mainly quartz and feldspar, so 2.65 a good average for particle density. To determine percent porosity, use the formula: Porosity (%) = (1-Bulk Density/2.65) X 100

¹ USDA NRCS. "Soil Quality Urban Technical Note No.2-Urban Soil Compaction". March 2000.

http://soils.usda.gov/sqi/management/files/sq_utn_2.pdf

* To determine how to calculate density see:

<http://www.globe.gov/tctg/bulkden.pdf?sectionID=94>

APPENDIX 2: Post-Construction Water Balance Performance Standard Spreadsheet

The discharger shall submit with their Notice of Intent (NOI) the following information to demonstrate compliance with the New and Re-Development Water Balance Performance Standard.

Map Instructions

The discharger must submit a small-scale topographic map of the site to show the existing contour elevations, pre- and post-construction drainage divides, and the total length of stream in each watershed area. Recommended scales include 1 in. = 20 ft., 1 in. = 30 ft., 1 in. = 40 ft., or 1 in. = 50 ft. The suggested contour interval is usually 1 to 5 feet, depending upon the slope of the terrain. The contour interval may be increased on steep slopes. Other contour intervals and scales may be appropriate given the magnitude of land disturbance.

Spreadsheet Instructions

The intent of the spreadsheet is to help dischargers calculate the project-related increase in runoff volume and select impervious area and runoff reduction credits to reduce the project-related increase in runoff volume to pre-project levels.

The discharger has the option of using the spreadsheet (**Appendix 2.1**) or a more sophisticated, watershed process-based model (e.g. Storm Water Management Model, Hydrological Simulation Program Fortran) to determine the project-related increase in runoff volume.

In Appendix 4.1, you must complete the worksheet for each land use/soil type combination for each project sub-watershed.

Steps 1 through 9 pertain specifically to the Runoff Volume Calculator:

Step 1: Enter the county where the project is located in cell H3.

Step 2: Enter the soil type in cell H6.

Step 3: Enter the existing pervious (dominant) land use type in cell H7.

Step 4: Enter the proposed pervious (dominant) land use type in cell H8.

Step 5: Enter the total project site area in cell H11 or J11.

Step 6: Enter the sub-watershed area in cell H12 or J12.

- Step 7: Enter the existing rooftop area in cell H17 or J17, the existing non-rooftop impervious area in cell H18 or J18, the proposed rooftop area in cell H19 or J19, and the proposed non-rooftop impervious area in cell H20 or J20
- Step 8: Work through each of the impervious area reduction credits and claim credits where applicable. Volume that cannot be addressed using non-structural practices must be captured in structural practices and approved by the Regional Water Board.
- Step 9: Work through each of the impervious volume reduction credits and claim credits where applicable. Volume that cannot be addressed using non-structural practices must be captured in structural practices and approved by the Regional Water Board.

Non-structural Practices Available for Crediting

- ***Porous Pavement***
- ***Tree Planting***
- ***Downspout Disconnection***
- ***Impervious Area Disconnection***
- ***Green Roof***
- ***Stream Buffer***
- ***Vegetated Swales***
- ***Rain Barrels and Cisterns***
- ***Landscaping Soil Quality***

APPENDIX 3

Bioassessment Monitoring Guidelines

Bioassessment monitoring is required for projects that meet all of the following criteria:

1. The project is rated Risk Level 3 or LUP Type 3
2. The project directly discharges runoff to a freshwater wadeable stream (or streams) that is either: (a) listed by the State Water Board or USEPA as impaired due to sediment, and/or (b) tributary to any downstream water body that is listed for sediment; and/or have the beneficial use SPAWN & COLD & MIGRATORY
3. Total project-related ground disturbance exceeds 30 acres.

For all such projects, the discharger shall conduct bioassessment monitoring, as described in this section, to assess the effect of the project on the biological integrity of receiving waters.

Bioassessment shall include:

1. The collection and reporting of specified instream biological data
2. The collection and reporting of specified instream physical habitat data

Bioassessment Exception

If a site qualifies for bioassessment, but construction commences out of an index period for the site location, the discharger shall:

1. Receive Regional Water Board approval for the sampling exception
2. Make a check payable to: Cal State Chico Foundation (SWAMP Bank Account) or San Jose State Foundation (SWAMP Bank Account) and include the WDID# on the check for the amount calculated for the exempted project.
3. Send a copy of the check to the Regional Water Board office for the site's region
4. Invest **7,500.00 X The number of samples required** into the SWAMP program as compensation (upon Regional Water Board approval).
5. Conduct bioassessment monitoring, as described in Appendix 4
6. Include the collection and reporting of specified instream biological data and physical habitat
7. Use the bioassessment sample collection and Quality Assurance & Quality Control (QA/QC) protocols developed by the State of California's Surface Water Ambient Monitoring Program (SWAMP)

Site Locations and Frequency

Macroinvertebrate samples shall be collected both before ground disturbance is initiated and after the project is completed. The "after" sample(s) shall be collected after at least one winter season resulting in surface runoff has transpired after project-related ground disturbance has ceased. "Before" and "after" samples shall be collected both upstream and downstream of the project's

discharge. Upstream samples should be taken immediately before the sites outfall and downstream samples should be taken immediately after the outfall (when safe to collect the samples). Samples should be collected for each freshwater wadeable stream that is listed as impaired due to sediment, or tributary to a water body that is listed for sediment. Habitat assessment data shall be collected concurrently with all required macroinvertebrate samples.

Index Period (Timing of Sample Collection)

Macroinvertebrate sampling shall be conducted during the time of year (i.e., the “index period”) most appropriate for bioassessment sampling, depending on ecoregion. This map is posted on the State Water Board’s Website: http://www.waterboards.ca.gov/water_issues/programs/stormwater/construction.shtml

Field Methods for Macroinvertebrate Collections

In collecting macroinvertebrate samples, the discharger shall use the “Reachwide Benthos (Multi-habitat) Procedure” specified in *Standard Operating Procedures for Collecting Benthic Macroinvertebrate Samples and Associated Physical and Chemical Data for Ambient Bioassessments in California* (Ode 2007).¹

Physical - Habitat Assessment Methods

The discharger shall conduct, concurrently with all required macroinvertebrate collections, the “Full” suite of physical habitat characterization measurements as specified in *Standard Operating Procedures for Collecting Benthic Macroinvertebrate Samples and Associated Physical and Chemical Data for Ambient Bioassessments in California* (Ode 2007), and as summarized in the Surface Water Ambient Monitoring Program’s *Stream Habitat Characterization Form — Full Version*.

Laboratory Methods

Macroinvertebrates shall be identified and classified according to the Standard Taxonomic Effort (STE) Level I of the Southwestern Association of Freshwater Invertebrate Taxonomists (SAFIT),² and using a fixed-count of 600 organisms per sample.

Quality Assurance

The discharger or its consultant(s) shall have and follow a quality assurance (QA) plan that covers the required bioassessment monitoring. The QA plan shall include, or be supplemented to include, a specific requirement for external QA checks (i.e., verification of taxonomic identifications and correction of data where errors are identified). External QA checks shall be performed on one of the

¹ This document is available on the Internet at: http://www.swrcb.ca.gov/swamp/docs/phab_sopr6.pdf.

² The current SAFIT STEs (28 November 2006) list requirements for both the Level I and Level II taxonomic effort, and are located at: http://www.swrcb.ca.gov/swamp/docs/safit/ste_list.pdf. When new editions are published by SAFIT, they will supersede all previous editions. All editions will be posted at the State Water Board’s SWAMP website.

discharger's macroinvertebrate samples collected per calendar year, or ten percent of the samples per year (whichever is greater). QA samples shall be randomly selected. The external QA checks shall be paid for by the discharger, and performed by the California Department of Fish and Game's Aquatic Bioassessment Laboratory. An alternate laboratory with equivalent or better expertise and performance may be used if approved in writing by State Water Board staff.

Sample Preservation and Archiving

The original sample material shall be stored in 70 percent ethanol and retained by the discharger until: 1) all QA analyses specified herein and in the relevant QA plan are completed; and 2) any data corrections and/or re-analyses recommended by the external QA laboratory have been implemented. The remaining subsampled material shall be stored in 70 percent ethanol and retained until completeness checks have been performed according to the relevant QA plan. The identified organisms shall be stored in 70 percent ethanol, in separate glass vials for each final ID taxon. (For example, a sample with 45 identified taxa would be archived in a minimum of 45 vials, each containing all individuals of the identified taxon.) Each of the vials containing identified organisms shall be labeled with taxonomic information (i.e., taxon name, organism count) and collection information (i.e., site name/site code, waterbody name, date collected, method of collection). The identified organisms shall be archived (i.e., retained) by the discharger for a period of not less than three years from the date that all QA steps are completed, and shall be checked at least once per year and "topped off" with ethanol to prevent desiccation. The identified organisms shall be relinquished to the State Water Board upon request by any State Water Board staff.

Data Submittal

The macroinvertebrate results (i.e., taxonomic identifications consistent with the specified SAFIT STEs, and number of organisms within each taxa) shall be submitted to the State Water Board in electronic format. The State Water Board's Surface Water Ambient Monitoring Program (SWAMP) is currently developing standardized formats for reporting bioassessment data. All bioassessment data collected after those formats become available shall be submitted using the SWAMP formats. Until those formats are available, the biological data shall be submitted in MS-Excel (or equivalent) format.³

The physical/habitat data shall be reported using the standard format titled *SWAMP Stream Habitat Characterization Form — Full Version*.⁴

³ Any version of Excel, 2000 or later, may be used.

⁴ Available at:

http://www.waterboards.ca.gov/water_issues/programs/swamp/docs/reports/fieldforms_fullversion052908.pdf

Invasive Species Prevention

In conducting the required bioassessment monitoring, the discharger and its consultants shall take precautions to prevent the introduction or spread of aquatic invasive species. At minimum, the discharger and its consultants shall follow the recommendations of the California Department of Fish and Game to minimize the introduction or spread of the New Zealand mudsnail.⁵

⁵ Instructions for controlling the spread of NZ mudsnails, including decontamination methods, can be found at: <http://www.dfg.ca.gov/invasives/mudsnail/>
More information on AIS More information on AIS
http://www.waterboards.ca.gov/water_issues/programs/swamp/ais/

Appendix 4 Sediment TMDLs

Implemented Sediment TMDLs in California. Construction was listed as a source in all fo these TMDLs in relation to road construction. Although construction was mentioned as a source, it was not given a specific allocation amount. The closest allocation amount would be for the road activity management WLA. **Implementation Phase** – Adoption process by the Regional Board, the State Water Resources Control Board, the Office of Administrative Law, and the US Environmental Protection Agency completed and TMDL being implemented.

A. Region	Type	Name	Pollutant Stressor	Potential Sources	TMDL Completion Date	Watershed Acres	WLA tons mi² yr
1 R1.epa.albionfinalt mdl	R	Albion River	Sedimentation	Road Construction	2001	43 acres	See A (table 6)

B Region	Type	Name	Pollutant Stressor	Potential Sources	TMDL Completion Date	Watershed Acres	WLA tons mi² yr
1 R1.epa.EelR- middle.mainSed.te mp	R	Middle Main Eel River and Tributaries (from Dos Rios to the South Fork)	Sedimentation Road	Construction	2005-2006 521	mi ²	100

C Region	Type	Name	Pollutant Stressor	Potential Sources	TMDL Completion Date	Watershed Acres	WLA tons mi² yr
1 R1.epa.EelRsouth. sed.temp	R	South Fork Eel River	Sedimentation	Road Construction	12 1999	See chart	473

D Region	Type	Name	Pollutant Stressor	Potential Sources	TMDL Completion Date	Watershed Acres	WLA tons mi² yr
1 R1.epa.bigfinaltmd l	R Big	River	Sedimentation	Road Construction	12 2001	181 mi ² watershed drainage	TMDL = loading capacity = nonpoint sources + background =

							393 t mi ² yr
--	--	--	--	--	--	--	--------------------------

E Region	Type	Name	Pollutant Stressor	Potential Sources	TMDL Completion Date	Watershed Acres	WLA tons mi² yr
1 R1.epa.EelR-lower.Sed.temp-121807-signed	R	Lower Eel River	Sedimentation	Road Construction	12 2007	300 square-mile watershed	898

F Region	Type	Name	Pollutant Stressor	Potential Sources	TMDL Completion Date	Watershed Acres	WLA tons mi² yr
1 R1.epa.EelR-middle.Sed.temp-	R	Middle Fork Eel River	Sedimentation	Road Construction	12 2003	753 mi ² (approx. 482,000 acres)	82

G Region	Type	Name	Pollutant Stressor	Potential Sources	TMDL Completion Date	Watershed Acres Mi²	WLA tons mi² yr
1 R1.epa.EelRnorth-Sed.temp.final-121807-signed	R	North Fork Eel River	Sedimentation	Road Construction	12 30 2002	289 (180,020 acres)	20

H Region	Type	Name	Pollutant Stressor	Potential Sources	TMDL Completion Date	Watershed Acres Mi²	WLA tons mi² yr
1 R1.epa.EelR-upper.mainSed.temp-	R	Upper Main Eel River and Tributaries (including Tomki Creek, Outlet Creek and Lake Pillsbury)	Sedimentation	Road Construction	12 29 2004	688 (approx. 440,384 acres)	14

I Region	Type	Name	Pollutant Stressor	Potential Sources	TMDL Completion Date	Watershed Acres	WLA tons mi ² yr
1 R1.epa.gualalafina ltmdl	R	Gualala River	Sedimentation	Road Construction	Not sure	300 (191,145 acres)	7

J Region	Type	Name	Pollutant Stressor	Potential Sources	TMDL Completion Date	Watershed Acres mi ²	WLA tons mi ² yr
1 R1.epa.Mad- sed.turbidity	R	Mad River	Sedimentation	Road Construction	12 21 2007	480	174

K Region	Type	Name	Pollutant Stressor	Potential Sources	TMDL Completion Date	Watershed Acres mi ²	WLA tons mi ² yr
1 R1.epa.mattole.se diment	R	Mattole River	Sedimentation	Road Construction	12 30 2003	296	27 or 520+27 = 547

L Region	Type	Name	Pollutant Stressor	Potential Sources	TMDL Completion Date	Watershed Acres mi ²	WLA tons mi ² yr
1 R1.epa.navarro.se d.temp	R	Navarro River	Sedimentation	Road Construction	Not sure	315 (201,600 acres).	50

M Region	Type	Name	Pollutant Stressor	Potential Sources	TMDL Completion Date	Watershed Acres mi ²	WLA tons mi ² yr
1 R1.epa.noyo.sedi ment	R	Noyo River	Sedimentation	Road Construction	12 16 1999	113 (72,323 acres)	68 (three areas measured) Table 16 in the TMDL

N Region	Type	Name	Pollutant Stressor	Potential Sources	TMDL Completion Date	Watershed Acres mi²	WLA tons mi² yr
1 R1.epa.RedwoodCk.sed	Cr	Redwood Creek	Sedimentation	Road Construction	12 30 1998	278	1900 Total allocation

O Region	Type	Name	Pollutant Stressor	Potential Sources	TMDL Completion Date	Watershed Acres mi²	WLA – Roads tons mi² yr
1 R1.epa.tenmile.sed	R	Ten Mile River	Sedimentation	Road Construction	2000	120	9

P Region	Type	Name	Pollutant Stressor	Potential Sources	TMDL Completion Date	Watershed Acres mi²	WLA management tons mi² yr
1 R1.epa.trinity.sed	R	Trinity River	Sedimentation	Road Construction	12 20 2001	2000 of 3000 covered in this TMDL	See rows below
1	Cr	Horse Linto Creek	Sedimentation	Road Construction	12 20 2001	64	528
1	Cr	Mill creek and Tish Tang	Sedimentation	Road Construction	12 20 2001	39	210
1	Cr	Willow Creek	Sedimentation	Road Construction	12 20 2001	43	94
1	Cr	Campbell Creek and Supply Creek	Sedimentation	Road Construction	12 20 2001	11	1961
1	Cr	Lower Mainstem and Coon Creek	Sedimentation	Road Construction	12 20 2001	32	63
1 R		Reference Subwatershed ¹	Sedimentation	Road Construction	12 20 2001	434	24
1	Cr	Canyon Creek	Sedimentation	Road	12 20 2001	64	326

				Construction			
1 R		Upper Tributaries ²	Sedimentation	Road Construction	12 20 2001	72	67
1 R		Middle Tributaries ³	Sedimentation	Road Construction	12 20 2001	54	53
1 R		Lower Tributaries ⁴	Sedimentation	Road Construction	12 20 2001	96	55
1	Cr	Weaver and Rush Creeks	Sedimentation	Road Construction	12 20 2001	72	169
1 Cr		Deadwood Creek Hoadley Gulch Poker Bar	Sedimentation	Road Construction	12 20 2001	47	68
1	L	Lewiston Lake	Sedimentation	Road Construction	12 20 2001	25	49
1 Cr		Grassvalley Creek	Sedimentation	Road Construction	12 20 2001	37	44
1	Cr	Indian Creek	Sedimentation	Road Construction	12 20 2001	34	81
1	Cr	Reading and Browns Creek	Sedimentation	Road Construction	12 20 2001	104	66
1 Cr		Reference Subwatersheds ⁵	Sedimentation	Road Construction	12 20 2001	235	281
1	L, Cr	Westside tributaries ⁶	Sedimentation	Road Construction	12 20 2001	93	105
1 R,	Cr, G	Upper trinity ⁷	Sedimentation	Road Construction	12 20 2001	161	690
1 R,	Cr, G	East Fork Tributaries ⁸	Sedimentation	Road Construction	12 20 2001	115	65
1	R, L	Eastside Tributaries ⁹	Sedimentation	Road Construction	12 20 2001	89	60

1 New River, Big French, Manzanita, North Fork, East Fork, North Fork

2 Dutch, Soldier, Oregon gulch, Conner Creek

3 Big Bar, Prairie Creek, Little French Creek

4 Swede, Italian, Canadian, Cedar Flat, Mill, McDonald, Hennessy, Quimby, Hawkins, Sharber

5 Stuarts Fork, Swift Creek, Coffee Creek

6 Stuart Arm, Stoney Creek, Mule Creek, East Fork, Stuart Fork, West Side Trinity Lake, Hatchet Creek, Buckeye Creek,

7 Upper Trinity River, Tangle Blue, Sunflower, Graves, Bear Upper Trinity Mainstream, Ramshorn Creek, Ripple Creek, Minnehaha Creek, Snowslide Gulch, Scorpion Creek

8 East Fork Trinity, Cedar Creek, Squirrel Gulch

9 East Side Tributaries, Trinity Lake

Q Region	Type	Name	Pollutant Stressor	Potential Sources	TMDL Completion Date	Watershed Acres mi ²	WLA tons mi ² yr
1 R1.epa.trinity.so.sed	R, Cr	South Fork Trinity River and Hayfork Creek	Sedimentation	Road Construction	12 1998	Not given, 19 miles long	33 (road total)

R Region	Type	Name	Pollutant Stressor	Potential Sources	TMDL Completion Date	Watershed Acres mi ²	WLA tons mi ² yr
1 R1.epa.vanduzen.sed	R, Cr	Van Duzen River and Yager Creek	Sedimentation	Various	12 16 1999	429	1353 total allocation
1		Upper Basin	Sedimentation	Road Construction			7
1		Middle Basin	Sedimentation	Road Construction			22
1		Lower Basin	Sedimentation	Road Construction			20

S Region	Type	Name	Pollutant Stressor	Potential Sources	TMDL Completion Date	Watershed Acres mi ²	WLA tons mi ² yr
6 R6.blackwood.sed Cr		Blackwood Creek (Placer County)	Bedded Sediment	Various	9 2007	11	17272 total

T Region	Type	Name	Pollutant Stressor	Potential Sources	TMDL Completion Date	Watershed Acres mi ²	WLA tons mi ² yr
6 R6.SquawCk.sed R		Squaw Creek (Placer County)	Sedimentation /controllable sources	Various – basin plan amendment	4 13 2006	8.2	10,900

Adopted TMDLs for Construction Sediment Sources

Region	Type	Name	Pollutant Stressor	Potential Sources	TMDL Completion Date	Watershed Area mi ²	Waste load Allocation tons mi ² yr
8 R		Newport Bay San Diego Creek Watershed	Sedimentation	Construction Land Development	1999 2.24	(1432 acres)	125,000 tons per Year (no more than 13,000 tons per year from construction sites)

Appendix 4 Non Sediment TMDLs

Region 1 Lost River-DIN and CBOD

Region 1 Source: Cal Trans Construction TMDL Completion Date: 12 30 2008 TMDL Type: River, Lake Watershed Area= 2996 mi ²	Pollutant Stressors/WLA	
	Dissolved inorganic nitrogen (DIN) (metric tons/yr)	Carbonaceous biochemical oxygen demand (CBOD) (metric tons/yr)
Lost River from the Oregon border to Tule Lake	.1 .2	
Tule Lake Refuge	.1	.2
Lower Klamath Refuge	.1	.2

Region 2 San Francisco Bay-Mercury

Region 2 Source:Non-Urban Stormwater Runoff TMDL Type: Bay	Name	Pollutant Stressor/WLA	TMDL Completion Date
	San Francisco Bay	Mercury 25 kg/year	08 09 2006

Region 4 Machado Lake Nutrients - Resolution No. 2008-006
(Effective Date - March 11, 2009)

General Construction Stormwater Permit WLAs	Years After Effective Date	Total Phosphorus (mg/L)	Total Nitrogen (TKN + NO3-N + NO2-N) (mg/L)
Interim WLAs ¹	At Effective Date	1.25	3.50
Interim WLAs ² 5	years	1.25	2.45
Final WLAs ²	9.5 years	0.10	1.00

¹ The compliance points for effective date interim WLAs are measured in the lake.

² No compliance points are specified for general construction stormwater permits for the year 5 interim WLAs and final WLAs

Region 4 Ballona Creek-Metals and Selenium – Resolution No. 2007-015
(Effective Date October 29, 2008)

Wet Weather WLAs

Region 4 Source: NPDES General Construction TMDL Completion Date: 10 29 2008 TMDL Type: Creek								
	Copper (Cu)		Lead (Pb)		Selenium (Se)		Zinc (Zn)	
	g/day	g/day/acre	g/day	g/day/acre	g/day	g/day/acre	g/day	g/day/acre
Ballona Creek	4.94E-07 x Daily storm volume (L)	2.20E-10 x Daily storm volume (L)	1.62E-06 x Daily storm volume (L)	7.20E-10 x Daily storm volume (L)	1.37E-07 x Daily storm volume (L)	6.10E-11 x Daily storm volume (L)	3.27E-06 x Daily storm volume (L)	1.45E-09 x Daily storm volume (L)

Wet-weather WLA Implementation

- Within seven years of the effective date of the TMDL, the construction industry will submit the results of BMP effectiveness studies to determine BMPs that will achieve compliance with the final waste load allocations assigned to construction storm water permittees.
- Regional Board staff will bring the recommended BMPs before the Regional Board for consideration within eight years of the effective date of the TMDL.
- General construction storm water permittees will be considered in compliance with final waste load allocations if they implement these Regional Board approved BMPs. All permittees must implement the approved BMPs within nine years of the effective date of the TMDL. If no effectiveness studies are conducted and no BMPs are approved by the Regional Board within eight years of the effective date of the TMDL, each general construction storm water permit holder will be subject to site-specific BMPs and monitoring requirements to demonstrate compliance with final waste load allocations.

Dry-weather WLAs

A waste load allocation of zero is assigned to all general construction storm water permits during dry weather.

Dry-weather WLA Implementation

Non-storm water flows authorized by the General Permit for Storm Water Discharges Associated with Construction Activity (Water Quality Order No. 99-08 DWQ), or any successor order, are exempt from the dry-weather waste load allocation equal to zero as long as they comply with the provisions of sections C.3 and A.9 of the Order No. 99-08 DWQ, which state that these authorized non-storm discharges shall be:

- (1) infeasible to eliminate
- (2) comply with BMPs as described in the Storm Water Pollution Prevention Plan prepared by the permittee, and
- (3) not cause or contribute to a violation of water quality standards, or comparable provisions in any successor order.

Unauthorized non-storm water flows are already prohibited by Order No. 99-08 DWQ.

Region 4 Los Angeles River and Tributaries-Metals- Resolution No. 2007-014
(Effective Date October 29, 2008)

Wet Weather WLAs

	Cadmium (Cd)		Copper (Cu)		Lead (Pb)		Zinc (Zn)								
	kg/day	g/day/acre	kg/day	g/day/acre	kg/day	g/day/acre	kg/day	g/day/acre							
5.9x10 ⁻¹¹	x	7.6x10 ⁻¹²	x	3.2x10 ⁻¹⁰	x	4.2x10 ⁻¹¹	x	1.2x10 ⁻⁹	x	1.5x10 ⁻¹⁰	x	3.01x10 ⁻⁹	x	3.9x10 ⁻¹⁰	x
	Daily storm volume (L)	Daily storm volume (L)	Daily storm volume (L)	Daily storm volume (L)	Daily storm volume (L)	Daily storm volume (L)	Daily storm volume (L)	Daily storm volume (L)	Daily storm volume (L)	Daily storm volume (L)	Daily storm volume (L)	Daily storm volume (L)	Daily storm volume (L)	Daily storm volume (L)	Daily storm volume (L)

Wet-weather WLA Implementation

- Within seven years of the effective date of the TMDL, the construction industry will submit the results of BMP effectiveness studies to determine BMPs that will achieve compliance with the final waste load allocations assigned to construction storm water permittees.
- Regional Board staff will bring the recommended BMPs before the Regional Board for consideration within eight years of the effective date of the TMDL.
- General construction storm water permittees will be considered in compliance with final waste load allocations if they implement these Regional Board approved BMPs. All permittees must implement the approved BMPs within nine years of the effective date of the TMDL. If no effectiveness studies are conducted and no BMPs are approved by the Regional Board within eight years of the effective date of the TMDL, each general construction storm water permit holder will be subject to site-specific BMPs and monitoring requirements to demonstrate compliance with final waste load allocations.

Dry-weather WLAs

A waste load allocation of zero is assigned to all general construction storm water permits during dry weather.

Dry-weather WLA Implementation

Non-storm water flows authorized by the General Permit for Storm Water Discharges Associated with Construction Activity (Water Quality Order No. 99-08 DWQ), or any successor order, are exempt from the dry-weather waste load allocation equal to zero as

long as they comply with the provisions of sections C.3 and A.9 of the Order No. 99-08 DWQ, which state that these authorized non-storm discharges shall be:

- (1) infeasible to eliminate
 - (2) comply with BMPs as described in the Storm Water Pollution Prevention Plan prepared by the permittee, and
 - (3) not cause or contribute to a violation of water quality standards, or comparable provisions in any successor order.
- Unauthorized non-storm water flows are already prohibited by Order No. 99-08 DWQ.

Region 4 Calleguas Creek Metals TMDL – Resolution No. 2006-012
(Effective Date - March 26, 2007)

Interim Limits and Final WLAs for Total Recoverable Copper, Nickel, and Selenium

Interim limits and waste load allocations are applied to receiving water.

A. Interim Limits

Constituents	Calleguas and Conejo Creek			Revolon Slough		
	Dry CMC (ug/L)	Dry CCC (ug/L)	Wet CMC (ug/L)	Dry CMC (ug/L)	Dry CCC (ug/L)	Wet CMC (ug/L)
Copper*	23	19	204	23	19	204
Nickel	15	13	(a)	15	13	(a)
Selenium	(b)	(b)	(b)	14	13	(a)

- (a) The current loads do not exceed the TMDL under wet conditions; interim limits are not required.
- (b) Selenium allocations have not been developed for this reach as it is not on the 303(d) list.
- (c) Attainment of interim limits will be evaluated in consideration of background loading data, if available.

B. Final WLAs for Total Recoverable Copper, Nickel, and Selenium

Dry-Weather WLAs in Water Column

Flow Range	Calleguas and Conejo Creek			Revolon Slough		
	Low Flow	Average Flow	Elevated Flow	Low Flow	Average Flow	Elevated Flow
Copper¹ (lbs/day)	0.04*WER 0.02	0.12*WER 0.02	0.18*WER 0.03	0.03*WER - 0.01	0.06*WER - 0.03	0.13*WER 0.02
Nickel (lbs/day)	0.100	0.120	0.440	0.050	0.069	0.116
Selenium (lbs/day)	(a)	(a)	(a)	0.004	0.003	0.004

¹ If site-specific WERs are approved by the Regional Board, TMDL waste load allocations shall be implemented in accordance with the approved WERs using the equations set forth above. Regardless of the final WERs, total copper loading shall not exceed current loading.

(a) Selenium allocations have not been developed for this reach as it is not on the 303(d) list.

Wet-Weather WLAs in Water Column

Constituent	Calleguas Creek	Revolon Slough
Copper¹ (lbs/day)	$(0.00054*Q^2*0.032*Q - 0.17)*WER - 0.06$	$(0.0002*Q^2+0.0005*Q)*WER$
Nickel² (lbs/day)	$0.014*Q^2+0.82*Q$	$0.027*Q^2+0.47*Q$
Selenium² (lbs/day)	(a)	$0.027*Q^2+0.47*Q$

¹ If site-specific WERs are approved by the Regional Board, TMDL waste load allocations shall be implemented in accordance with the approved WERs using the equations set forth above. Regardless of the final WERs, total copper loading shall not exceed current loading.

² Current loads do not exceed loading capacity during wet weather. Sum of all loads cannot exceed loads presented in the table

(a) Selenium allocations have not been developed for this reach as it is not on the 303(d) list.

Q: Daily storm volume.

Interim Limits and Final WLAs for Mercury in Suspended Sediment

Flow Range	Calleguas Creek		Revolon Slough	
	Interim (lbs/yr)	Final (lbs/yr)	Interim (lbs/yr)	Final (lbs/yr)
0-15,000 MGY	3.3	0.4	1.7	0.1
15,000-25,000 MGY	10.5	1.6	4	0.7
Above 25,000 MGY	64.6	9.3	10.2	1.8

MGY: million gallons per year.

In accordance with current practice, a group concentration-based WLA has been developed for all permitted stormwater discharges, including municipal separate storm sewer systems (MS4s), Caltrans, general industrial and construction stormwater permits, and Naval Air Weapons Station Point Mugu. Dischargers will have a required 25%, 50% and 100% reduction in the difference between the current loadings and the load allocations at 5, 10 and 15 years after the effective date, respectively. Achievement of required reductions will be evaluated based on progress towards BMP implementation as outlined in the urban water quality management plans (UWQMPs). If the interim reductions are not met, the dischargers will submit a report to the Executive Officer detailing why the reductions were not met and the steps that will be taken to meet the required reductions.

Region 4 Calleguas Creek-OC Pesticides, PCBs, and Siltation (Resolution 2005-010)
Effective Date - March 24, 2006

Interim Requirements

Region 4 Calleguas Creek Source: Minor NPDES point sources/WDRs TMDL Completion Date: 3 24 2006 TMDL Type:Creek	Pollutant Stressor	WLA Daily Max (µg/L)	WLA Monthly Ave (µg/L)
	Chlordane 1.2		0.59
	4,4-DDD 1.7		0.84
	4,4-DDE 1.2		0.59
	4,4-DDT 1.2		0.59
	Dieldrin 0.28		0.14
	PCB's 0.34		0.17
	Toxaphene 0.33		0.16

Region 4 Calleguas Creek-Calleguas Creek Toxicity (Resolution 2005-009)
Effective Date - March 24, 2006

Minor sources include NPDES permittees other than POTWs and MS4s, discharging to the Calleguas Creek Watershed. A wasteload of 1.0 TUC is allocated to the minor point sources discharging to the Calleguas Creek Watershed. Additionally, the following wasteloads for chlorpyrifos and diazinon are established. Final WLAs apply as of March 24, 2006.

Chlorpyrifos WLAs, ug/L

Final WLA
 (4 day)
 0.014

Diazinon WLAs, ug/L

Final WLA
 Acute and Chronic
 0.10

Region 4 Calleguas Creek-Salts (Resolution 2007-016)
Effective Date – December 2, 2008

Final Dry Weather Pollutant WLA (mg/L)					
Region 4 Calleguas Creek Source Permitted Stormwater Dischargers TMDL Completion Date: 12 2 2008 TMDL Type:Creek	Critical Condition Flow Rate (mgd)	Chloride (lb/day)	TDS (lb/day)	Sulfate (lb/day)	Boron (lb/day)
Simi	1.39	1738 9849 2897	12		
Las Posas	0.13	157 887 261	N/A		
Conejo	1.26	1576 8931 2627	N/A		
Camarillo	0.06	72	406 119	N/A	
Pleasant Valley (Calleguas)	0.12	150 850 250	N/A		
Pleasant Valley (Revolon)	0.25	314	1778	523	2
Dry Weather Interim Pollutant WLA (mg/L)					
		Chloride (mg/L)	TDS (mg/L)	Sulfate (mg/L)	Boron (mg/L)

Simi 230.0		1720.0	1289.0	1.3
Las Posas	230	1720	1289	1.3
Conejo 230		1720	1289	1.3
Camarillo 230		1720	1289	1.3
Pleasant Valley (Calleguas)	230	1720	1289	1.3
Pleasant Valley (Revolon)	230	1720	1289	1.3

- Dry- weather waste load allocations apply in the receiving water at the base of each subwatershed. Dry weather allocations apply when instream flow rates are below the 86th percentile flow and there has been no measurable precipitation in the previous 24 hours.
- Because wet weather flows transport a large mass of salts at low concentrations, these dischargers meet water quality objectives during wet weather. No wet weather allocations are assigned.

Ballona Creek Toxic Pollutants (Resolution No. 2005-008)
Effective Date - January 11, 2006

Each storm water permittee enrolled under the general construction or industrial storm water permits will receive an individual waste load allocation on a per acre basis, based on the acreage of their facility.

Metals per Acre WLAs for Individual General

Construction or Industrial Storm Water Permittees (g/yr/ac)

Cadmium	Copper	Lead	Silver	Zinc
0.1	3 4 0.1			13

Organics per Acre WLAs for Individual General

Construction or Industrial Storm Water Permittees (mg/yr/ac)

Chlordane	DDTs	Total PCBs	Total PAHs
0.04	0.14	2	350

Waste load allocations will be incorporated into the State Board general permit upon renewal or into a watershed specific general construction storm water permit developed by the Regional Board.

Within seven years of the effective date of the TMDL, the construction industry will submit the results of BMP effectiveness studies to determine BMPs that will achieve compliance with the waste load allocations assigned to construction storm water permittees. Regional Board staff will bring the recommended BMPs before the Regional Board for consideration within eight years of the

effective date of the TMDL. General construction storm water permittees will be considered in compliance with waste load allocations if they implement these Regional Board approved BMPs.

All general construction permittees must implement the approved BMPs within nine years of the effective date of the TMDL. If no effectiveness studies are conducted and no BMPs are approved by the Regional Board within eight years of the effective date of the TMDL, each general construction storm water permit holder will be subject to site-specific BMPs and monitoring requirements to demonstrate compliance with waste load allocations.

Region 4 Marina Del Rey Harbor Toxic Pollutants TMDL (Resolution No. 2005-012)
Effective Date March 22, 2006

Each storm water permittee enrolled under the general construction or industrial storm water permits will receive an individual waste load allocation on a per acre basis, based on the acreage of their facility.

Metals per Acre WLAs for Individual General Construction or Industrial Storm Water Permittees (g/yr/ac)

Copper	Lead	Zinc
2.3	3.1	10

Organics per acre WLAs for Individual General Construction or Industrial Storm Water Permittees (mg/yr/ac)

Chlordane	Total PCBs
0.03	1.5

Waste load allocations will be incorporated into the State Board general permit upon renewal or into a watershed specific general construction storm water permit developed by the Regional Board.

Within seven years of the effective date of the TMDL, the construction industry will submit the results of BMP effectiveness studies to determine BMPs that will achieve compliance with the waste load allocations assigned to construction storm water permittees. Regional Board staff will bring the recommended BMPs before the Regional Board for consideration within eight years of the effective date of the TMDL. General construction storm water permittees will be considered in compliance with waste load allocations if they implement these Regional Board approved BMPs.

All general construction permittees must implement the approved BMPs within nine years of the effective date of the TMDL. If no effectiveness studies are conducted and no BMPs are approved by the Regional Board within eight years of the effective date of

the TMDL, each general construction storm water permit holder will be subject to site-specific BMPs and monitoring requirements to demonstrate compliance with waste load allocations.

Region 4 San Gabriel River and Tributaries-Metals and Selenium (EPA-established TMDL – Effective date: 3/26/07)

Wet-weather allocations

Waterbody	Copper	Lead	Zinc
San Gabriel River Reach 2*		0.8 kg/d	
Coyote Creek**	0.513 kg/d	2.07 kg/d	3.0 kg/d

*Mass-based allocations are based on a flow of 260 cfs (daily storm volume = 6.4×10^8 liters)

**Mass-based allocations are based on a flow of 156 cfs (daily storm volume = 3.8×10^8 liters)

Dry-weather allocations

The dry-weather copper waste load allocation for general construction storm water permittees that discharge to San Gabriel Reach 1, Coyote Creek, and the Estuary is zero.

The dry-weather selenium allocation for general construction storm water permittees that discharge to San Jose Creek Reach 1 and Reach 2 is 5 µg/L (total recoverable metals).

Region 4 Upper Santa Clara River Chloride TMDL Adopted by Resolution No 2006-016
Effective Date June 12, 2008

“Other NPDES dischargers” have a chloride WLA equal to 100 mg/L.

This TMDL was revised by Resolution No 2008-012, which, when it becomes effective, includes the following conditional WLAs for “Other minor NPDES discharges”:

Reach	Concentration-based Conditional WLA for Chloride (mg/L)*
6	150 (12-month Average), 230 (Daily Maximum)
5	150 (12-month Average), 230 (Daily Maximum)
4B	117 (3-month Average), 230 (Daily Maximum)

*The conditional WLAs for chloride for all point sources shall apply only when chloride load reductions and/or chloride export projects are in operation by the Santa Clarita Valley Sanitation District according to the implementation plan for the TMDL. If these conditions are not met, WLAs shall be based on existing water quality objectives for chloride of 100 mg/L.

Region 4 The Harbor Beaches of Ventura County-Bacteria (Adopted by Resolution No. 2007-017)
Effective Date – December 18, 2008

Current and future enrollees in the Statewide Construction Activity Storm Water General Permit in the Channel Islands Harbor subwatershed are assigned WLAs of zero (0) days of allowable exceedances of the single sample limits and the rolling 30-day geometric mean limits.

Single Sample Limits are:

- a. Total coliform density shall not exceed 10,000/100 ml.
- b. Fecal coliform density shall not exceed 400/100 ml.
- c. Enterococcus density shall not exceed 104/100 ml.
- d. Total coliform density shall not exceed 1,000/100 ml, if the ratio of fecal-to-total coliform exceeds 0.1.

Rolling 30-day Geometric Mean Limits are:

- a. Total coliform density shall not exceed 1,000/100 ml.
- b. Fecal coliform density shall not exceed 200/100 ml.
- c. Enterococcus density shall not exceed 35/100 ml.

Los Angeles Harbor Bacteria TMDL (Adopted by Resolution No. 2004-001)
Effective Date – March 10, 2005

Current and future enrollees in the Statewide Construction Activity Storm Water General Permit in the watershed are assigned WLAs of zero (0) days of allowable exceedances of the single sample limits and the rolling 30-day geometric mean.

Single Sample Limits are:

- a. Total coliform density shall not exceed 10,000/100 ml.
- b. Fecal coliform density shall not exceed 400/100 ml.
- c. Enterococcus density shall not exceed 104/100 ml.
- d. Total coliform density shall not exceed 1,000/100 ml, if the ratio of fecal-to-total coliform exceeds 0.1.

Rolling 30-day Geometric Mean Limits are:

- a. Total coliform density shall not exceed 1,000/100 ml.
- b. Fecal coliform density shall not exceed 200/100 ml.
- c. Enterococcus density shall not exceed 35/100 ml.

Ballona Creek Bacteria TMDL (Adopted by Resolution No. 2006-011)
Effective Date – April 27, 2007

Current and future enrollees in the Statewide Construction Activity Storm Water General Permit in the watershed are assigned WLAs of zero (0) days of allowable exceedances of the single sample limits and the rolling 30-day geometric mean.

Single Sample Limits are:

- a. Total coliform density shall not exceed 10,000/100 ml.
- b. Fecal coliform density shall not exceed 400/100 ml.
- c. Enterococcus density shall not exceed 104/100 ml.
- d. Total coliform density shall not exceed 1,000/100 ml, if the ratio of fecal-to-total coliform exceeds 0.1.

Rolling 30-day Geometric Mean Limits are:

- a. Total coliform density shall not exceed 1,000/100 ml.
- b. Fecal coliform density shall not exceed 200/100 ml.
- c. Enterococcus density shall not exceed 35/100 ml.

Region 4 Resolution No. 03-009 Los Angeles River and Tributaries-Nutrients

Minor Point Sources

Waste loads are allocated to minor point sources enrolled under NPDES or WDR permits including but not limited to Tapia WRP, Whittier Narrows WRP, Los Angeles Zoo WRP, industrial and construction stormwater, and municipal storm water and urban runoff from municipal separate storm sewer systems (MS4s)

Region 4 Minor Point Sources for NPDES/WDR Permits TMDL Effective Date: 3 23 2004 TMDL Type: River	Pollutant Stressor/WLA				
	Total Ammonia (NH ₃)		Nitrate-nitrogen (NO ₃ -N)	Nitrite-nitrogen (NO ₂ -N)	NO ₃ -N + NO ₃ -N
	1 Hr Ave mg/l	30 Day Ave mg/l	30 Day Ave mg/l		30 Day Ave mg/l
LA River Above Los Angeles-Glendale WRP (LAG)	4.7 1.6 8.0			1.0	8.0
LA River Below LAG	8.7	2.4	8.0	1.0	8.0
Los Angeles Tributaries 10.1		2.3	8.0	1.0	8.0

Malibu Creek Attachment A to Resolution No. 2004-019R-Bacteria

Effective date: 1 24 2006. The WLAs for permittees under the NPDES General Stormwater Construction Permit are zero (0) days of allowable exceedances for the single sample limits and the rolling 30-day geometric mean.

Single Sample Limits are:

- a. Total coliform density shall not exceed 10,000/100 ml.
- b. Fecal coliform density shall not exceed 400/100 ml.
- c. Enterococcus density shall not exceed 104/100 ml.
- d. Total coliform density shall not exceed 1,000/100 ml, if the ratio of fecal-to-total coliform exceeds 0.1.

Rolling 30-day Geometric Mean Limits are:

- a. Total coliform density shall not exceed 1,000/100 ml.
- b. Fecal coliform density shall not exceed 200/100 ml.
- c. Enterococcus density shall not exceed 35/100 ml.

Region 4 Marina del Rey Harbor, Mothers' Beach and Back Basins
Attachment A to Resolution No. 2003-012-Bacteria

Effective date: 3 18 2004. Discharges from general construction storm water permits are not expected to be a significant source of bacteria. Therefore, the WLAs for these discharges are zero (0) days of allowable exceedances for the single sample limits and the rolling 30-day geometric mean. Any future enrollees under a general NPDES permit, general industrial storm water permit or general construction storm water permit within the MdR Watershed will also be subject to a WLA of zero days of allowable exceedances.

Single Sample Limits are:

- a. Total coliform density shall not exceed 10,000/100 ml.
- b. Fecal coliform density shall not exceed 400/100 ml.
- c. Enterococcus density shall not exceed 104/100 ml.
- d. Total coliform density shall not exceed 1,000/100 ml, if the ratio of fecal-to-total coliform exceeds 0.1.

Rolling 30-day Geometric Mean Limits are:

- a. Total coliform density shall not exceed 1,000/100 ml.
- b. Fecal coliform density shall not exceed 200/100 ml.
- c. Enterococcus density shall not exceed 35/100 ml.

Santa Clara River Nutrients TMDL (Adopted by Resolution No. 2003-011
Effective Date - March 23, 2004

Concentration-based wasteloads are allocated to municipal, industrial and construction stormwater sources regulated under NPDES permits. For stormwater permittees discharging into Reach 7, the thirty-day WLA for ammonia as nitrogen is 1.75 mg/L and the one-hour WLA for ammonia as nitrogen is 5.2 mg/L; the thirty-day average WLA for nitrate plus nitrite as nitrogen is 6.8 mg/L. For stormwater permittees discharging into Reach 3, the thirty-day WLA for ammonia as nitrogen is 2.0 mg/L and the one-hour WLA for ammonia as nitrogen is 4.2 mg/L; the thirty-day average WLA for nitrate plus nitrite nitrogen is 8.1 mg/L.

Region 8 RESOLUTION NO. R8-2007- 0024

Total Maximum Daily Loads (TMDLs) for San Diego Creek,
Upper and Lower Newport Bay, Orange County, California

Region 8 NPDES Construction Permit TMDL Completion Date: 1 24 1995 TMDL Type: River. Cr, Bay	Organochlorine Compounds							
	Total DDT		Chlordane		Total PCBs		Toxaphene	
	g/day	g/yr	g/day	g/yr	g/day	g/yr	g/day	g/yr
San Diego Creek	.27	99.8	.18*	64.3*	.09*	31.5*	.004	1.5
Upper Newport Bay	.11	40.3	.06	23.4	.06	23.2	X	X
Lower Newport Bay	.04	14.9	.02	8.6	.17	60.7	X	X

*Red= Informational WLA only, not for enforcement purposes

Organochlorine Compounds TMDLs Implementation Tasks and Schedule

Regional Board staff shall develop a SWPPP Improvement Program that identifies the Regional Board’s expectations with respect to the content of SWPPPs, including documentation regarding the selection and implementation of BMPs, and a sampling and analysis plan. The Improvement Program shall include specific guidance regarding the development and implementation of monitoring plans, including the constituents to be monitored, sampling frequency and analytical protocols. The SWPPP Improvement Program shall be completed by *(the date of OAL approval of this BPA)*. **No later than two months** from completion of the Improvement Program, Board staff shall assure that the requirements of the Program are communicated to interested parties, including dischargers with existing authorizations under the General Construction Permit. Existing, authorized dischargers shall revise their project SWPPPs as needed to address the Program requirements as soon as possible but **no later than (three months of completion of the SWPPP Improvement Program)**. Applicable SWPPPs that do not adequately address the Program requirements shall be considered inadequate and enforcement by the Regional Board shall proceed accordingly. The Caltrans and Orange County MS4 permits shall be revised as needed to assure that the permittees communicate the Regional Board’s SWPPP expectations, based on the SWPPP Improvement Program, with the Standard Conditions of Approval.

APPENDIX 5: Glossary

Active Areas of Construction

All areas subject to land surface disturbance activities related to the project including, but not limited to, project staging areas, immediate access areas and storage areas. All previously active areas are still considered active areas until final stabilization is complete. [The construction activity Phases used in this General Permit are the Preliminary Phase, Grading and Land Development Phase, Streets and Utilities Phase, and the Vertical Construction Phase.]

Active Treatment System (ATS)

A treatment system that employs chemical coagulation, chemical flocculation, or electrocoagulation to aid in the reduction of turbidity caused by fine suspended sediment.

Acute Toxicity Test

A chemical stimulus severe enough to rapidly induce a negative effect; in aquatic toxicity tests, an effect observed within 96 hours or less is considered acute.

Air Deposition

Airborne particulates from construction activities. .

Approved Signatory

A person who has legal authority to sign, certify, and electronically submit Permit Registration Documents and Notices of Termination on behalf of the Legally Responsible Person.

Beneficial Uses

As defined in the California Water Code, beneficial uses of the waters of the state that may be protected against quality degradation include, but are not limited to, domestic, municipal, agricultural and industrial supply; power generation; recreation; aesthetic enjoyment; navigation; and preservation and enhancement of fish, wildlife, and other aquatic resources or preserves.

Best Available Technology Economically Achievable (BAT)

As defined by USEPA, BAT is a technology-based standard established by the Clean Water Act (CWA) as the most appropriate means available on a national basis for controlling the direct discharge of toxic and nonconventional pollutants to navigable waters. The BAT effluent limitations guidelines, in general, represent the best existing performance of treatment technologies that are economically achievable within an industrial point source category or subcategory.

Best Conventional Pollutant Control Technology (BCT)

As defined by USEPA, BCT is a technology-based standard for the discharge from existing industrial point sources of conventional pollutants including biochemical oxygen demand (BOD), total suspended sediment (TSS), fecal coliform, pH, oil and grease.

Best Professional Judgment (BPJ)

The method used by permit writers to develop technology-based NPDES permit conditions on a case-by-case basis using all reasonably available and relevant data.

Best Management Practices (BMPs)

BMPs are scheduling of activities, prohibitions of practices, maintenance procedures, and other management practices to prevent or reduce the discharge of pollutants. BMPs also include treatment requirements, operating procedures, and practices to control site runoff, spillage or leaks, sludge or waste disposal, or drainage from raw material storage.

Chain of Custody (COC)

Form used to track sample handling as samples progress from sample collection to the analytical laboratory. The COC is then used to track the resulting analytical data from the laboratory to the client. COC forms can be obtained from an analytical laboratory upon request.

Coagulation

The clumping of particles in a discharge to settle out impurities, often induced by chemicals such as lime, alum, and iron salts.

Common Plan of Development

Generally a contiguous area where multiple, distinct construction activities may be taking place at different times under one plan. A plan is generally defined as any piece of documentation or physical demarcation that indicates that construction activities may occur on a common plot. Such documentation could consist of a tract map, parcel map, demolition plans, grading plans or contract documents. Any of these documents could delineate the boundaries of a common plan area. However, broad planning documents, such as land use master plans, conceptual master plans, or broad-based CEQA or NEPA documents that identify potential projects for an agency or facility are not considered common plans of development.

Daily Average Discharge

The discharge of a pollutant measured during any 24-hour period that reasonably represents a calendar day for purposes of sampling. For pollutants with limitations expressed in units of mass, the daily discharge is calculated as the total mass of the pollutant discharged during the day. For pollutants with limitations expressed in other units of measurement (e.g., concentration) the daily discharge is calculated as the average measurement of the pollutant

throughout the day (40 CFR 122.2). In the case of pH, the pH must first be converted from a log scale.

Debris

Litter, rubble, discarded refuse, and remains of destroyed inorganic anthropogenic waste.

Direct Discharge

A discharge that is routed directly to waters of the United States by means of a pipe, channel, or ditch (including a municipal storm sewer system), or through surface runoff.

Discharger

The Legally Responsible Person (see definition) or entity subject to this General Permit.

Dose Rate (for ATS)

In exposure assessment, dose (e.g. of a chemical) per time unit (e.g. mg/day), sometimes also called dosage.

Drainage Area

The area of land that drains water, sediment, pollutants, and dissolved materials to a common outlet.

Effluent

Any discharge of water by a discharger either to the receiving water or beyond the property boundary controlled by the discharger.

Effluent Limitation

Any numeric or narrative restriction imposed on quantities, discharge rates, and concentrations of pollutants which are discharged from point sources into waters of the United States, the waters of the contiguous zone, or the ocean.

Erosion

The process, by which soil particles are detached and transported by the actions of wind, water, or gravity.

Erosion Control BMPs

Vegetation, such as grasses and wildflowers, and other materials, such as straw, fiber, stabilizing emulsion, protective blankets, etc., placed to stabilize areas of disturbed soils, reduce loss of soil due to the action of water or wind, and prevent water pollution.

Field Measurements

Testing procedures performed in the field with portable field-testing kits or meters.

Final Stabilization

All soil disturbing activities at each individual parcel within the site have been completed in a manner consistent with the requirements in this General Permit.

First Order Stream

Stream with no tributaries.

Flocculants

Substances that interact with suspended particles and bind them together to form flocs.

Good Housekeeping BMPs

BMPs designed to reduce or eliminate the addition of pollutants to construction site runoff through analysis of pollutant sources, implementation of proper handling/disposal practices, employee education, and other actions.

Grading Phase (part of the Grading and Land Development Phase)

Includes reconfiguring the topography and slope including; alluvium removals; canyon cleanouts; rock undercuts; keyway excavations; land form grading; and stockpiling of select material for capping operations.

Hydromodification

Hydromodification is the alteration of the hydrologic characteristics of coastal and non-coastal waters, which in turn could cause degradation of water resources. Hydromodification can cause excessive erosion and/or sedimentation rates, causing excessive turbidity, channel aggradation and/or degradation.

Identified Organisms

Organisms within a sub-sample that is specifically identified and counted.

Inactive Areas of Construction

Areas of construction activity that are not active and those that have been active and are not scheduled to be re-disturbed for at least 14 days.

Index Period

The period of time during which bioassessment samples must be collected to produce results suitable for assessing the biological integrity of streams and rivers. Instream communities naturally vary over the course of a year, and sampling during the index period ensures that samples are collected during a time frame when communities are stable so that year-to-year consistency is obtained. The index period approach provides a cost-effective alternative to year-round sampling. Furthermore, sampling within the appropriate index period will yield results that are comparable to the assessment thresholds or criteria for a given region, which are established for the same index period. Because index

periods differ for different parts of the state, it is essential to know the index period for your area.

K Factor

The soil erodibility factor used in the Revised Universal Soil Loss Equation (RUSLE). It represents the combination of detachability of the soil, runoff potential of the soil, and the transportability of the sediment eroded from the soil.

Legally Responsible Person

The person who possesses the title of the land or the leasehold interest of a mineral estate upon which the construction activities will occur for the regulated site. For linear underground/overhead projects, it is in the person in charge of the utility company, municipality, or other public or private company or agency that owns or operates the LUP.

Likely Precipitation Event

Any weather pattern that is forecasted to have a 50% or greater chance of producing precipitation in the project area. The discharger shall obtain likely precipitation forecast information from the National Weather Service Forecast Office (e.g., by entering the zip code of the project's location at <http://www.srh.noaa.gov/forecast>).

Maximum Allowable Threshold Concentration (MATC)

The allowable concentration of residual, or dissolved, coagulant/flocculant in effluent. The MATC shall be coagulant/flocculant-specific, and based on toxicity testing conducted by an independent, third-party laboratory. A typical MATC would be:

The MATC is equal to the geometric mean of the NOEC (No Observed Effect Concentration) and LOEC (Lowest Observed Effect Concentration) Acute and Chronic toxicity results for most sensitive species determined for the specific coagulant. The most sensitive species test shall be used to determine the MATC.

Natural Channel Evolution

The physical trend in channel adjustments following a disturbance that causes the river to have more energy and degrade or aggrade more sediment. Channels have been observed to pass through 5 to 9 evolution types. Once they pass through the suite of evolution stages, they will rest in a new state of equilibrium.

Non-Storm Water Discharges

Discharges are discharges that do not originate from precipitation events. They can include, but are not limited to, discharges of process water, air conditioner condensate, non-contact cooling water, vehicle wash water, sanitary wastes, concrete washout water, paint wash water, irrigation water, or pipe testing water.

Non-Visible Pollutants

Pollutants associated with a specific site or activity that can have a negative impact on water quality, but cannot be seen through observation (ex: chlorine). Such pollutants being discharged are not authorized.

Numeric Action Level (NAL)

Level is used as a warning to evaluate if best management practices are effective and take necessary corrective actions. Not an effluent limit.

Original Sample Material

The material (i.e., macroinvertebrates, organic material, gravel, etc.) remaining after the subsample has been removed for identification.

pH

Unit universally used to express the intensity of the acid or alkaline condition of a water sample. The pH of natural waters tends to range between 6 and 9, with neutral being 7. Extremes of pH can have deleterious effects on aquatic systems.

Post-Construction BMPs

Structural and non-structural controls which detain, retain, or filter the release of pollutants to receiving waters after final stabilization is attained.

Preliminary Phase (Pre-Construction Phase - Part of the Grading and Land Development Phase)

Construction stage including rough grading and/or disking, clearing and grubbing operations, or any soil disturbance prior to mass grading.

Project**Qualified SWPPP Developer**

Individual who is authorized to develop and revise SWPPPs.

Qualified SWPPP Practitioner

Individual assigned responsibility for non-storm water and storm water visual observations, sampling and analysis, and responsibility to ensure full compliance with the permit and implementation of all elements of the SWPPP, including the preparation of the annual compliance evaluation and the elimination of all unauthorized discharges.

Qualifying Rain Event

Any event that produces 0.5 inches or more precipitation with a 48 hour or greater period between rain events.

R Factor

Erosivity factor used in the Revised Universal Soil Loss Equation (RUSLE). The R factor represents the erosivity of the climate at a particular location. An

average annual value of R is determined from historical weather records using erosivity values determined for individual storms. The erosivity of an individual storm is computed as the product of the storm's total energy, which is closely related to storm amount, and the storm's maximum 30-minute intensity.

Rain Event Action Plan (REAP)

Written document, specific for each rain event, that when implemented is designed to protect all exposed portions of the site within 48 hours of any likely precipitation event.

Remaining Sub sampled Material

The material (e.g., organic material, gravel, etc.) that remains after the organisms to be identified have been removed from the subsample for identification. (Generally, no macroinvertebrates are present in the remaining subsampled material, but the sample needs to be checked and verified using a complete Quality Assurance (QA) plan)

Routine Maintenance

Activities intended to maintain the original line and grade, hydraulic capacity, or original purpose of a facility.

Runoff Control BMPs

Measures used to divert runoff from offsite and runoff within the site.

Run-on

Discharges that originate offsite and flow onto the property of a separate project site.

Revised Universal Soil Loss Equation (RUSLE)

Empirical model that calculates average annual soil loss as a function of rainfall and runoff erosivity, soil erodibility, topography, erosion controls, and sediment controls.

Sampling and Analysis Plan

Document that describes how the samples will be collected, under what conditions, where and when the samples will be collected, what the sample will be tested for, what test methods and detection limits will be used, and what methods/procedures will be maintained to ensure the integrity of the sample during collection, storage, shipping and testing (i.e., quality assurance/quality control protocols).

Sediment

Solid particulate matter, both mineral and organic, that is in suspension, is being transported, or has been moved from its site of origin by air, water, gravity, or ice and has come to rest on the earth's surface either above or below sea level.

Sedimentation

Process of deposition of suspended matter carried by water, wastewater, or other liquids, by gravity. It is usually accomplished by reducing the velocity of the liquid below the point at which it can transport the suspended material.

Sediment Control BMPs

Practices that trap soil particles after they have been eroded by rain, flowing water, or wind. They include those practices that intercept and slow or detain the flow of storm water to allow sediment to settle and be trapped (e.g., silt fence, sediment basin, fiber rolls, etc.).

Settleable Solids (SS)

Solid material that can be settled within a water column during a specified time frame. It is typically tested by placing a water sample into an Imhoff settling cone and then allowing the solids to settle by gravity for a given length of time.

Results are reported either as a volume (mL/L) or a mass (mg/L) concentration.

Sheet Flow

Flow of water that occurs overland in areas where there are no defined channels where the water spreads out over a large area at a uniform depth.

Site**Soil Amendment**

Any material that is added to the soil to change its chemical properties, engineering properties, or erosion resistance that could become mobilized by storm water.

Streets and Utilities Phase

Construction stage including excavation and street paving, lot grading, curbs, gutters and sidewalks, public utilities, public water facilities including fire hydrants, public sanitary sewer systems, storm sewer system and/or other drainage improvements.

Structural Controls

Any structural facility designed and constructed to mitigate the adverse impacts of storm water and urban runoff pollution

Suspended Sediment Concentration (SSC)

The measure of the concentration of suspended solid material in a water sample by measuring the dry weight of all of the solid material from a known volume of a collected water sample. Results are reported in mg/L.

Total Suspended Solids (TSS)

The measure of the suspended solids in a water sample includes inorganic substances, such as soil particles and organic substances, such as algae,

aquatic plant/animal waste, particles related to industrial/sewage waste, etc. The TSS test measures the concentration of suspended solids in water by measuring the dry weight of a solid material contained in a known volume of a sub-sample of a collected water sample. Results are reported in mg/L.

Toxicity

The adverse response(s) of organisms to chemicals or physical agents ranging from mortality to physiological responses such as impaired reproduction or growth anomalies.

Turbidity

The cloudiness of water quantified by the degree to which light traveling through a water column is scattered by the suspended organic and inorganic particles it contains. The turbidity test is reported in Nephelometric Turbidity Units (NTU) or Jackson Turbidity Units (JTU).

Vertical Construction Phase

The Build out of structures from foundations to roofing, including rough landscaping.

Waters of the United States

Generally refers to surface waters, as defined by the federal Environmental Protection Agency in 40 C.F.R. § 122.2.¹

Water Quality Objectives (WQO)

Water quality objectives are defined in the California Water Code as limits or levels of water quality constituents or characteristics, which are established for the reasonable protection of beneficial uses of water or the prevention of nuisance within a specific area.

¹ The application of the definition of “waters of the United States” may be difficult to determine; there are currently several judicial decisions that create some confusion. If a landowner is unsure whether the discharge must be covered by this General Permit, the landowner may wish to seek legal advice.

APPENDIX 6: Acronym List

ASBS	Areas of Special Biological Significance
ASTM	American Society of Testing and Materials; Standard Test Method for Particle-Size Analysis of Soils
ATS	Active Treatment System
BASMAA	Bay Area Storm water Management Agencies Association
BAT	Best Available Technology Economically Achievable
BCT	Best Conventional Pollutant Control Technology
BMP	Best Management Practices
BOD	Biochemical Oxygen Demand
BPJ	Best Professional Judgment
CAFO	Confined Animal Feeding Operation
CCR	California Code of Regulations
CEQA	California Environmental Quality Act
CFR	Code of Federal Regulations
CGP	NPDES General Permit for Storm Water Discharges Associated with Construction Activities
CIWQS	California Integrated Water Quality System
CKD	Cement Kiln Dust
COC	Chain of Custody
CPESC	Certified Professional in Erosion and Sediment Control
CPSWQ	Certified Professional in Storm Water Quality
CSMP	Construction Site Monitoring Program
CTB	Cement Treated Base
CTR	California Toxics Rule
CWA	Clean Water Act
CWC	California Water Code
CWP	Center for Watershed Protection
DADMAC	Diallyldimethyl-ammonium chloride
DDNR	Delaware Department of Natural Resources
DFG	Department of Fish and Game
DHS	Department of Health Services
DWQ	Division of Water Quality
EC	Electrical Conductivity
ELAP	Environmental Laboratory Accreditation Program
EPA	Environmental Protection Agency
ESA	Environmentally Sensitive Area
ESC	Erosion and Sediment Control
HSPF	Hydrologic Simulation Program Fortran
JTU	Jackson Turbidity Units
LID	Low Impact Development
LOEC	Lowest Observed Effect Concentration
LRP	Legally Responsible Person
LUP	Linear Underground/Overhead Projects

MATC	Maximum	Allowable Threshold Concentration
MDL	Method	Detection Limits
MRR		Monitoring and Reporting Requirements
MS4		Municipal Separate Storm Sewer System
MUSLE		Modified Universal Soil Loss Equation
NAL		Numeric Action Level
NEL		Numeric Effluent Limitation
NICET		National Institute for Certification in Engineering Technologies
NOAA		National Oceanic and Atmospheric Administration
NOEC		No Observed Effect Concentration
NOI		Notice of Intent
NOT		Notice of Termination
NPDES		National Pollutant Discharge Elimination System
NRCS		Natural Resources Conservation Service
NTR		National Toxics Rule
NTU		Nephelometric Turbidity Units
O&M	Operation	and Maintenance
PAC	Polya	luminum chloride
PAM	Polyacryla	mide
PASS	Polya	luminum chloride Silica/sulfate
POC	Pollutants	of Concern
PoP	Probability	of Precipitation
POTW		Publicly Owned Treatment Works
PRDs		Permit Registration Documents
PWS	Planning	Watershed
QAMP		Quality Assurance Management Plan
QA/QC		Quality Assurance/Quality Control
REAP		Rain Event Action Plan
Regional Board		Regional Water Quality Control Board
ROWD		Report of Waste Discharge
RUSLE		Revised Universal Soil Loss Equation
RW	Receiv	ing Water
SMARTS System		Storm water Multi Application Reporting and Tracking
SS	Settleable	Solids
SSC		Suspended Sediment Concentration
SUSMP		Standard Urban Storm Water Mitigation Plan
SW	Storm	Water
SWARM		Storm Water Annual Report Module
SWAMP		Surface Water Ambient Monitoring Program
SWMM		Storm Water Management Model
SWMP		Storm Water Management Program
SWPPP		Storm Water Pollution Prevention Plan
TC	Treatment	Control
TDS	Total	Dissolved Solids

TMDL	Total Maximum Daily Load
TSS Total	Suspended Solids
USACOE	U.S. Army Corps of Engineers
USC United	States Code
USEPA	United States Environmental Protection Agency
USGS	United States Geological Survey
WDID Waste	Discharge Identification Number
WDR Waste	Discharge Requirements
WLA Waste	Load Allocation
WET Whole	Effluent Toxicity
WRCC	Western Regional Climate Center
WQBEL	Water Quality Based Effluent Limitation
WQO Water	Quality Objective
WQS Water	Quality Standard

APPENDIX 7: State and Regional Water Resources Control Board Contacts

NORTH COAST REGION (1)
5550 Skylane Blvd, Ste. A
Santa Rose, CA 95403
(707) 576-2220 FAX: (707)523-0135

SAN FRANCISCO BAY REGION (2)
1515 Clay Street, Ste. 1400
Oakland, CA 94612
(510) 622-2300 FAX: (510) 622-2640

CENTRAL COAST REGION (3)
895 Aerovista Place, Ste 101
San Luis Obispo, CA 93401
(805) 549-3147 FAX: (805) 543-0397

LOS ANGELES REGION (4)
320 W. 4th Street, Ste. 200
Los Angeles, CA 90013
(213) 576-6600 FAX: (213) 576-6640

LAHONTAN REGION (6 SLT)
2501 Lake Tahoe Blvd.
South Lake Tahoe, CA 96150
(530) 542-5400 FAX: (530) 544-2271

VICTORVILLE OFFICE (6V)
14440 Civic Drive, Ste. 200
Victorville, CA 92392-2383
(760) 241-6583 FAX: (760) 241-7308

CENTRAL VALLEY REGION (5S)
11020 Sun Center Dr., #200
Rancho Cordova, CA 95670-6114
(916) 464-3291 FAX: (916) 464-4645

FRESNO BRANCH OFFICE (5F)
1685 E St.
Fresno, CA 93706
(559) 445-5116 FAX: (559) 445-5910

REDDING BRANCH OFFICE (5R)
415 Knollcrest Drive, Ste. 100
Redding, CA 96002
(530) 224-4845 FAX: (530) 224-4857

COLORADO RIVER BASIN REGION (7)
73-720 Fred Waring Dr., Ste. 100
Palm Desert, CA 92260
(760) 346-7491 FAX: (760) 341-6820

SANTA ANA REGION (8)
3737 Main Street, Ste. 500
Riverside, CA 92501-3339
Phone (951) 782-4130 FAX: (951) 781-6288

SAN DIEGO REGION (9)
9174 Sky Park Court, Ste. 100
San Diego, CA 92123-4340
(858) 467-2952 FAX: (858) 571-6972

STATE WATER BOARD
PO Box 1977
Sacramento, CA 95812-1977
stormwater@waterboards.ca.gov

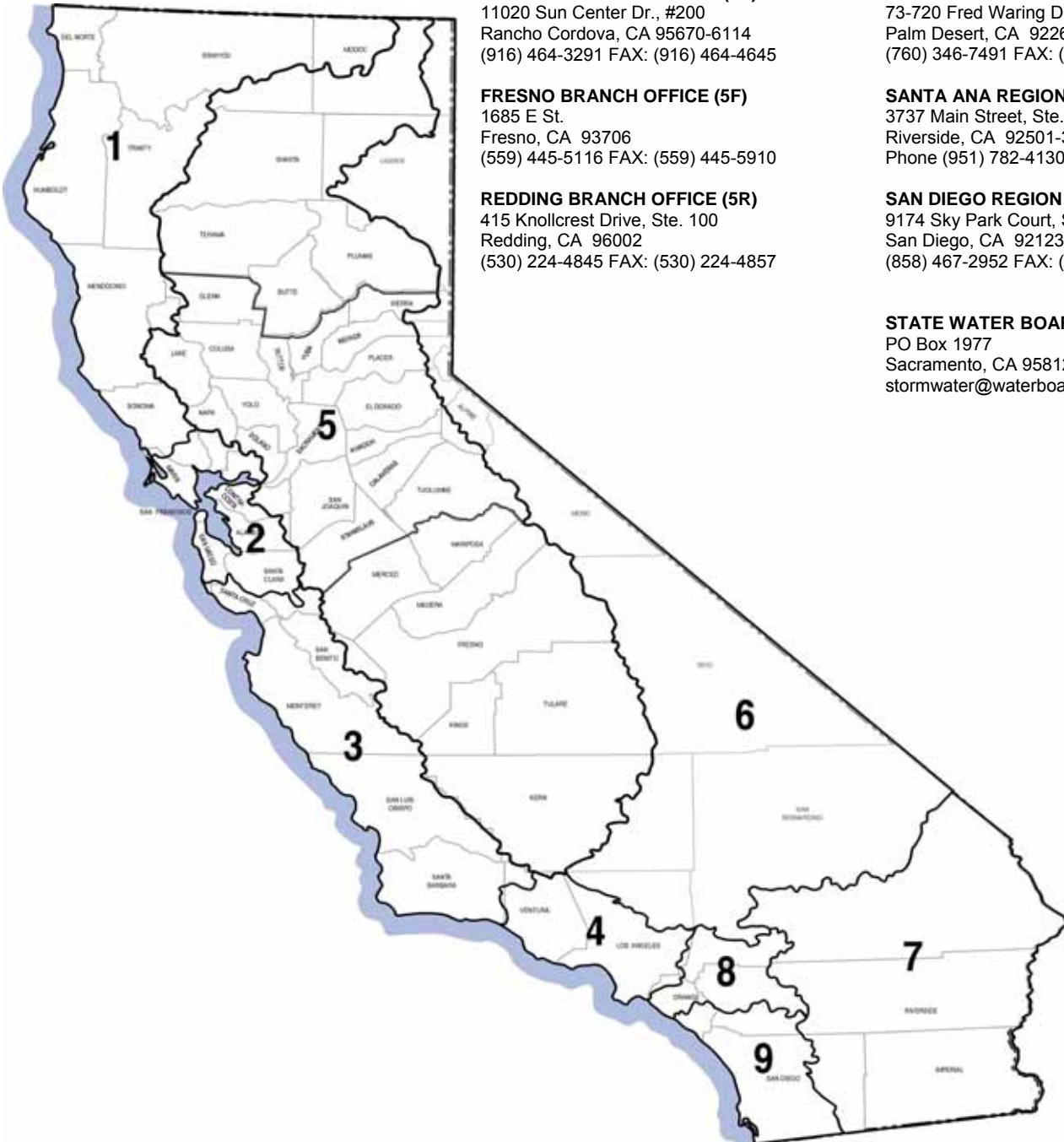

Appendix III

Site Map

VICINITY MAP

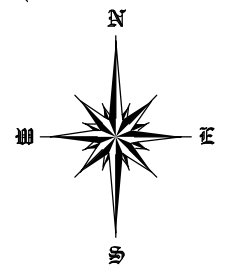
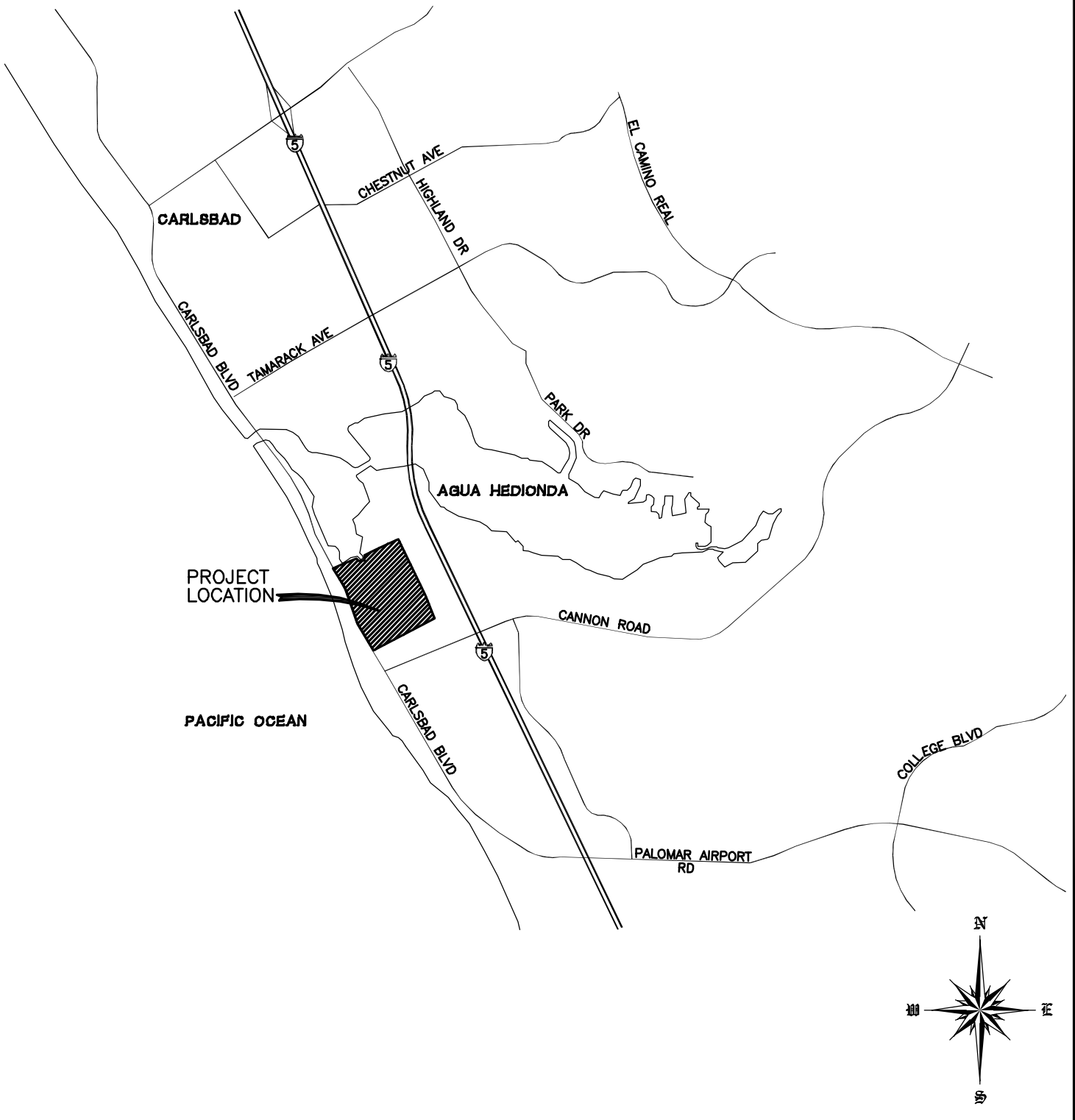

Bureau Veritas North America, Inc.

11590 West Bernardo Court Suite 100
San Diego, CA 92127-1624
Tel: (858) 451-6100 Fax: (858) 451-2846
www.us.bureauveritas.com

**ENCINA SUBSTATION
CARLSBAD, CA**

SCALE: NTS

DRAWN BY: TB

DATE: 3/25/10

SHEET 1 OF 1

Retain in this Appendix the current
and all historic Site Maps

NOTE:

NOT ALL ITEMS INDICATED IN LEGENDS AND NOTES APPLY TO EACH SHEET.

EROSION CONTROL PLAN LEGEND:

DESCRIPTION	SEE CON. NOTE #	CALTRANS/SDG&E WATER QUALITY CONSTRUCTION BMP MANUAL STD. DWG.	SYMBOL
FIBER ROLLS	①	SC-5/BMP 1-03	FR
RUN-OFF COLLECTION POINT PROTECTION	②	SC-10/BMP 1-06	[Grid Symbol]
ENERGY DISSIPATOR	③	SS-10	[Stippled Symbol]
STABILIZED CONSTRUCTION ENTRANCE	④	TC-1/BMP-1-07	[Hatched Symbol]
GRAVEL BAG BERM	⑤	SC-6/BMP 1-04	—GBB—
PAVING AND GRINDING OPERATIONS	⑥	NS-3/BMP 3-02 & 3-05	[Hatched Symbol]
GRAVEL CHECK DAM	⑦	SC-4/BMP 1-04	[Hatched Symbol]
STRUCTURE DEMOLITION/REMOVAL OVER OR ADJACENT TO WATERS	⑧	NS-15	[Hatched Symbol]
OVER-WATER PROTECTION	⑨	BMP 3-08	[Hatched Symbol]
BORING LOCATION	⑩		⊙
ENVIRONMENTALLY SENSITIVE AREA	⑪	(SEE CONSTRUCTION NOTE)	
STORM DRAIN INLET PROTECTION	⑫	SC-10/BMP 1-06	[Grid Symbol]
RUN ON/RUN OFF SAMPLING LOCATION			▲/★

CONSTRUCTION NOTES:

- INSTALL FIBER ROLLS. SEE BMP SHEETS SC-5/BMP 1-03 FOR INSTALLATION, MAINTENANCE, AND INSPECTION INSTRUCTIONS AND PROCEDURES.
- INSTALL RUN-OFF COLLECTION POINT PROTECTION. SEE BMP SHEETS SC-10/BMP 1-06 FOR INSTALLATION, MAINTENANCE, AND INSPECTION INSTRUCTIONS AND PROCEDURES.
- INSTALL ENERGY DISSIPATION DEVICES. SEE BMP SHEET SS-10 FOR APPLICATION, MAINTENANCE, AND INSPECTION INSTRUCTIONS AND PROCEDURES.
- INSTALL STABILIZED CONSTRUCTION ENTRANCE/TRACKING CONTROLS WITH RUMBLE RACK. SEE BMP SHEETS TC-1/BMP-1-07 INSTALLATION, INSPECTION, AND MAINTENANCE INSTRUCTIONS AND PROCEDURES.
- INSTALL GRAVEL BAG BERM, TWO BAGS HIGH. SEE BMP SHEETS SC-6/BMP 1-04 FOR INSTALLATION, MAINTENANCE, AND INSPECTION INSTRUCTIONS AND PROCEDURES.
- PERFORM PAVING AND GRINDING OPERATIONS. SEE BMP SHEETS NS-3/BMP 3-02 AND BMP 3-05 FOR APPLICATION, MAINTENANCE, AND INSPECTION INSTRUCTIONS AND PROCEDURES.
- INSTALL GRAVEL BAG CHECK DAM. SEE BMP SHEETS SC-4/BMP 1-04 FOR INSTALLATION, MAINTENANCE, AND INSPECTION INSTRUCTIONS AND PROCEDURES.
- PERFORM STRUCTURE DEMOLITION/REMOVAL OVER OR ADJACENT TO WATERS. SEE BMP SHEET NS-15 FOR APPLICATION, MAINTENANCE, AND INSPECTION INSTRUCTIONS AND PROCEDURES.
- INSTALL OVER-WATER PROTECTION. SEE BMP SHEET BMP 3-08 FOR APPLICATION, MAINTENANCE, AND INSPECTION INSTRUCTIONS AND PROCEDURES.
- A 10' RADIUS CIRCLE OF FIBER ROLLS SHALL BE PLACED NEAR THE BORING SITE PRIOR TO THE START OF GEOTECHNICAL INVESTIGATION. SPOILS SHALL BE PLACED WITHIN THE CIRCLE AND RECOMPACTED TO MATCH NATIVE SOIL AFTER COMPLETION OF THE BORING.
- CONSTRUCTION ACTIVITIES SHALL AVOID IMPACTS TO ENVIRONMENTALLY SENSITIVE AND/OR JURISDICTIONAL DELINEATED AREAS TO THE MAXIMUM EXTENT PRACTICAL. ENVIRONMENTAL RESOURCE MANAGER TO DELINEATE WITH TEMPORARY ORANGE FENCING.
- INSTALL STORM DRAIN INLET PROTECTION. SEE BMP SHEETS SC-10/BMP 1-08 FOR INSTALLATION, MAINTENANCE, INSPECTION INSTRUCTIONS AND PROCEDURES.
- MATERIAL DELIVERY AND STORAGE LOCATION. SEE BMP SHEETS WM-1/BMP 2-01 FOR SPECIFICATIONS, MAINTENANCE, AND INSPECTION INSTRUCTIONS AND PROCEDURES.

EROSION AND SEDIMENT CONTROL NOTES:

- FOR BMP SHEETS REFER TO CALTRANS (MARCH 2003) AND SDG&E WATER QUALITY CONSTRUCTION BEST MANAGEMENT PRACTICES MANUAL (DECEMBER 2002) AND PROJECTS FINAL APPROVED SWPPP.
- CONTRACTOR TO IMPLEMENT STREET SWEEPING AND VACUUMING (PER BMP SHEET SC-7/BMP 1-07) ALONG ALL AREAS OF THE OFFSITE EXISTING PAVED ROADWAY WHERE SEDIMENT IS OBSERVED.
- IF DISCHARGES FROM IRRIGATION LINES, POTABLE WATER LINES, OR HYDRANT FLUSHING OCCUR ONSITE, CONTRACTOR MUST IMPLEMENT POTABLE WATER/IRRIGATION PER BMP SHEET NS-7, AS NECESSARY.
- CONTRACTOR ALSO TO IMPLEMENT THE FOLLOWING CONSTRUCTION BMPs, AS NECESSARY:
 - SCHEDULING, PER BMP SHEETS EC-1/BMP 1-01
 - WIND EROSION CONTROL, PER BMP SHEETS WE-1/BMP 4-08
 - WATER CONSERVATION PRACTICES, PER BMP SHEET NS-1
 - ILLICIT CONNECTION/DISCHARGE, PER BMP SHEETS NS-6/BMP 2-06
- NO WORK HAVING THE POTENTIAL TO CAUSE WATER POLLUTION, AS DETERMINED BY THE ENGINEER, SHALL BE PERFORMED UNTIL THE SWPPP HAS BEEN SUBMITTED TO THE ENGINEER BY THE CONTRACTOR, AND APPROVED.
- THE CONTRACTOR SHALL CONSIDER OTHER CONTROL MEASURES, AS NECESSARY, TO SUPPLEMENT THE CRITICAL TEMPORARY CONTROL MEASURES SHOWN ON THESE PLANS, IN ORDER TO MEET THE POLLUTION CONTROL OBJECTIVES OF THE SWPPP.
- VEHICLE AND EQUIPMENT CLEANING, FUELING, AND/OR MAINTENANCE (PER BMP SHEETS NS-6/BMP 3-03, NS-9/BMP 3-04, AND NS-10 RESPECTIVELY) SHALL NOT BE PERFORMED ON SITE.

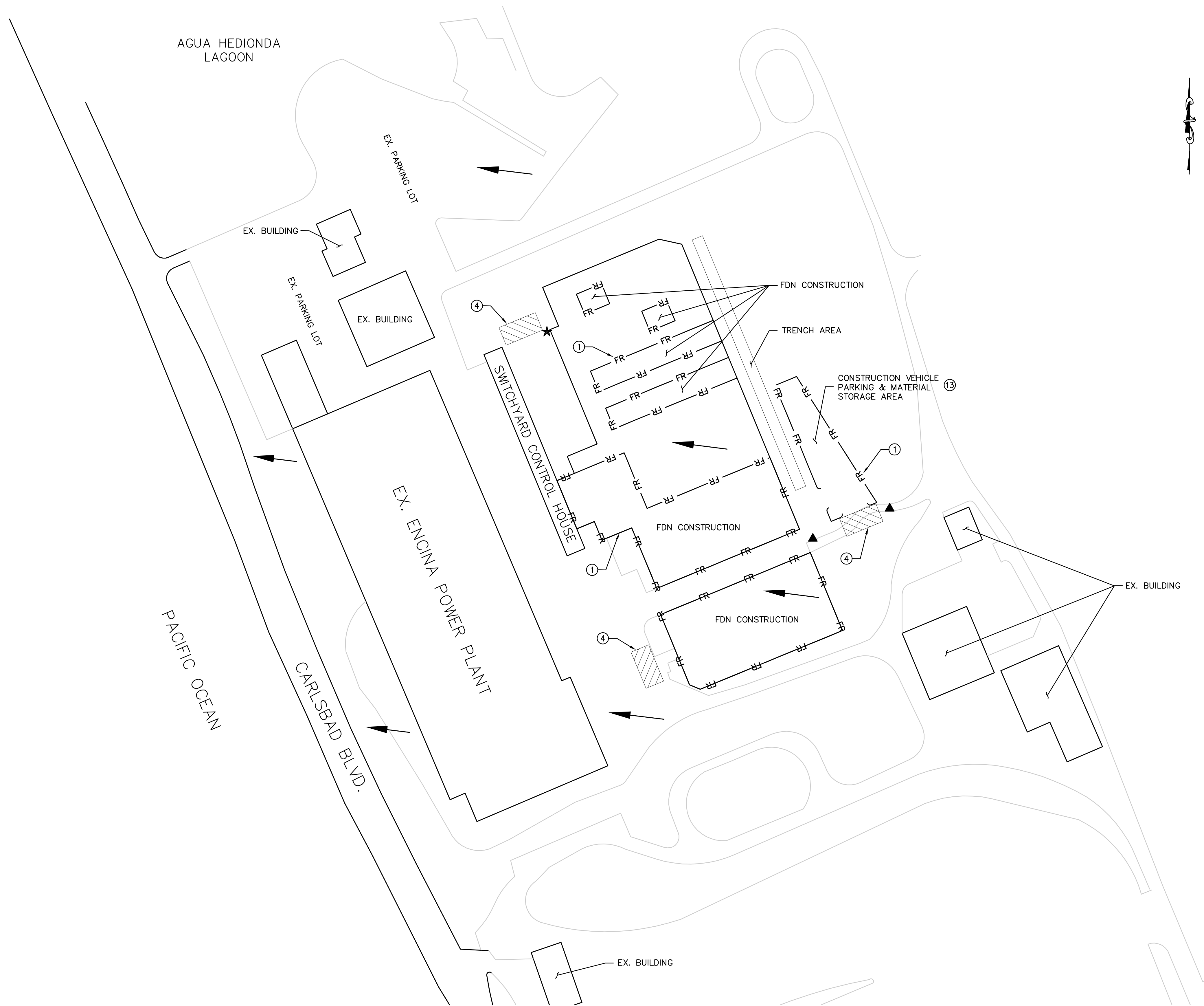

ENCINA SUBSTATION PLAN
SCALE: 1" = 100'

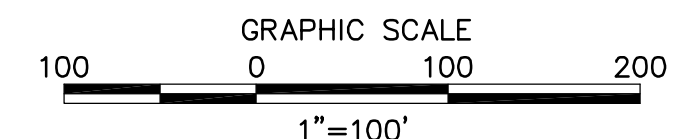

REVISIONS

NO.	WORK DONE	DATE	BY:	APP'D:	NO.	WORK DONE	DATE	BY:	APP'D:	NO.	WORK DONE	DATE	BY:	APP'D:	NO.

Bureau Veritas North America
11590 West Bernardo Court Suite 100
San Diego, CA 92127-1624
Tel: (858) 451-6100 Fax: (858) 451-2846
www.us.bureauveritas.com

SAN DIEGO GAS & ELECTRIC COMPANY
SAN DIEGO, CALIFORNIA

EROSION CONTROL PLANS FOR
ENCINA SUBSTATION
230kV & 138kV ULTIMATE GENERAL ARRANGMENT

DRAWN BY: 00 DATE: SCALE: 1" = 30' W.O. REV. 0
CHECKED BY: DATE:
APPROVED BY: DATE:
CAD NO.: PLOT SCALE: 1" = 1"

06-ENCINA-01-EC

P:\16920 SDGE SWPPPs\CADD\EROSION CONTROL\6-Encina\Plan\Encina_Substation.dwg\Jul-22-2010 12:25

Appendix IV

Calculations / Analysis



U.S. ENVIRONMENTAL PROTECTION AGENCY

National Pollutant Discharge Elimination System (NPDES)

[Recent Additions](#) | [Contact Us](#) | [Print Version](#) Search NPDES:

[EPA Home](#) > [OW Home](#) > [OWM Home](#) > [NPDES Home](#) >

Basic Information

NPDES Topics

Alphabetical Index

Glossary

About NPDES

eNOI

Municipal MS4s

Construction Activities

Industrial Activities

Road-Related MS4s

Menu of BMPs

Green Infrastructure

Urban BMP Tool

Stormwater Home

Rainfall Erosivity Factor Calculator for Small Construction Sites

Facility Information

Facility Name: Encina Substation
 Start Date: 10/15/2010
 End Date: 03/01/2012
 Latitude: 33.1383
 Longitude: -117.3338

Erosivity Index Calculator Results

AN EROSIVITY INDEX VALUE OF **65.34** HAS BEEN DETERMINED FOR THE CONSTRUCTION PERIOD OF **10/15/2010 - 03/01/2012**.

A rainfall erosivity factor of 5.0 or greater has been calculated for your site and period of construction. **You do not qualify for a waiver from NPDES permitting requirements.**



Stormwater Information
Recent Additions
FAQs
Publications
Regulations
Training & Meetings
Links
Contacts



The documents on this site are best viewed with Acrobat 8.0

[Office of Water](#) | [Office of Wastewater Management](#) | [Disclaimer](#) | [Search EPA](#)

[EPA Home](#) | [Privacy and Security Notice](#) | [Contact Us](#)

Last updated on August 07, 2009 3:37 PM

URL: http://cfpub.epa.gov/npdes/stormwater/lew/erosivity_index_result.cfm

	A	B	C
1	Sediment Risk Factor Worksheet		Entry
2	A) R Factor		
3	Analyses of data indicated that when factors other than rainfall are held constant, soil loss is directly proportional to a rainfall factor composed of total storm kinetic energy (E) times the maximum 30-min intensity (I30) (Wischmeier and Smith, 1958). The numerical value of R is the average annual sum of EI30 for storm events during a rainfall record of at least 22 years. "Isoerodent" maps were developed based on R values calculated for more than 1000 locations in the Western U.S. Refer to the link below to determine the R factor for the project site.		
4	http://cfpub.epa.gov/npdes/stormwater/LEW/lewCalculator.cfm		
5	R Factor Value		65.34
6	B) K Factor (weighted average, by area, for all site soils)		
7	The soil-erodibility factor K represents: (1) susceptibility of soil or surface material to erosion, (2) transportability of the sediment, and (3) the amount and rate of runoff given a particular rainfall input, as measured under a standard condition. Fine-textured soils that are high in clay have low K values (about 0.05 to 0.15) because the particles are resistant to detachment. Coarse-textured soils, such as sandy soils, also have low K values (about 0.05 to 0.2) because of high infiltration resulting in low runoff even though these particles are easily detached. Medium-textured soils, such as a silt loam, have moderate K values (about 0.25 to 0.45) because they are moderately susceptible to particle detachment and they produce runoff at moderate rates. Soils having a high silt content are especially susceptible to erosion and have high K values, which can exceed 0.45 and can be as large as 0.65. Silt-size particles are easily detached and tend to crust, producing high rates and large volumes of runoff. Use Site-specific data must be submitted.		
8	Site-specific K factor guidance		
9	K Factor Value		0.2
10	C) LS Factor (weighted average, by area, for all slopes)		
11	The effect of topography on erosion is accounted for by the LS factor, which combines the effects of a hillslope-length factor, L, and a hillslope-gradient factor, S. Generally speaking, as hillslope length and/or hillslope gradient increase, soil loss increases. As hillslope length increases, total soil loss and soil loss per unit area increase due to the progressive accumulation of runoff in the downslope direction. As the hillslope gradient increases, the velocity and erosivity of runoff increases. Use the LS table located in separate tab of this spreadsheet to determine LS factors. Estimate the weighted LS for the site prior to construction.		
12	LS Table		
13	LS Factor Value		0.43
14			
15	Watershed Erosion Estimate (=RxKxLS) in tons/acre		5.61924
16	Site Sediment Risk Factor		Low
17	Low Sediment Risk: < 15 tons/acre		
18	Medium Sediment Risk: >=15 and <75 tons/acre		
19	High Sediment Risk: >= 75 tons/acre		
20			

Receiving Water (RW) Risk Factor Worksheet	Entry	Score
A. Watershed Characteristics	yes/no	
A.1. Does the disturbed area discharge (either directly or indirectly) to a 303(d)-listed waterbody impaired by sediment (For help with impaired waterbodies please visit the link below) or has a USEPA approved TMDL implementation plan for sediment ?:	no	Low
http://www.waterboards.ca.gov/water_issues/programs/tmdl/integrated2010.shtml		
OR		
A.2. Does the disturbed area discharge to a waterbody with designated beneficial uses of SPAWN & COLD & MIGRATORY? (For help please review the appropriate Regional Board Basin Plan)		
http://www.waterboards.ca.gov/waterboards_map.shtml		
Region 1 Basin Plan Region 2 Basin Plan Region 3 Basin Plan Region 4 Basin Plan Region 5 Basin Plan Region 6 Basin Plan Region 7 Basin Plan Region 8 Basin Plan Region 9 Basin Plan		

Combined Risk Level Matrix

		<u>Sediment Risk</u>		
		Low	Medium	High
<u>Receiving Water Risk</u>	Low	Level 1	Level 2	
	High	Level 2		Level 3

Project Sediment Risk: **Low**

Project RW Risk: **Low**

Project Combined Risk: **Level 1**

Computation Sheet for Determining Runoff Coefficients

$$\text{Total Site Area} = \underline{\quad 3.3 \quad} \quad (\text{A})$$

Existing Site Conditions

$$\text{Impervious Site Area}^1 = \underline{\quad 2.81 \quad} \quad (\text{B})$$

$$\text{Impervious Site Area Runoff Coefficient}^{2,4} = \underline{\quad 0.95 \quad} \quad (\text{C})$$

$$\text{Pervious Site Area}^3 = \underline{\quad 0.5 \quad} \quad (\text{D})$$

$$\text{Pervious Site Area Runoff Coefficient}^4 = \underline{\quad 0.30 \quad} \quad (\text{E})$$

$$\text{Existing Site Area Runoff Coefficient} \quad \frac{(\text{B} \times \text{C}) + (\text{D} \times \text{E})}{(\text{A})} = \underline{\quad 0.85 \quad} \quad (\text{F})$$

Proposed Site Conditions (after construction)

$$\text{Impervious Site Area}^1 = \underline{\quad 3.14 \quad} \quad (\text{G})$$

$$\text{Impervious Site Area Runoff Coefficient}^{2,4} = \underline{\quad 0.95 \quad} \quad (\text{H})$$

$$\text{Pervious Site Area}^3 = \underline{\quad 0.17 \quad} \quad (\text{I})$$

$$\text{Pervious Site Area Runoff Coefficient}^4 = \underline{\quad 0.40 \quad} \quad (\text{J})$$

$$\text{Proposed Site Area Runoff Coefficient} \quad \frac{(\text{G} \times \text{H}) + (\text{I} \times \text{J})}{(\text{A})} = \underline{\quad 0.92 \quad} \quad (\text{K})$$

1. Includes paved areas, areas covered by buildings, and other impervious surfaces.
2. Use 0.95 unless lower or higher runoff coefficient can be verified.
3. Includes areas of vegetation, most unpaved or uncovered soil surfaces, and other pervious areas.
4. See the table on the following page for typical C values.

Table 819.2B
Runoff Coefficients for
Developed Areas

Type of Drainage Area	Runoff Coefficient
Business:	
Downtown areas	0.70 - 0.95
Neighborhood areas	0.50 - 0.70
Residential:	
Single-family areas	0.30 - 0.50
Multi-units, detached	0.40 - 0.60
Multi-units, attached	0.60 - 0.75
Suburban	0.25 - 0.40
Apartment dwelling areas	0.50 - 0.70
Industrial:	
Light areas	0.50 - 0.80
Heavy areas	0.60 - 0.90
Parks, cemeteries:	0.10 - 0.25
Playgrounds:	0.20 - 0.40
Railroad yard areas:	0.20 - 0.40
Unimproved areas:	0.10 - 0.30
Lawns:	
Sandy soil, flat, 2%	0.05 - 0.10
Sandy soil, average, 2-7%	0.10 - 0.15
Sandy soil, steep, 7%	0.15 - 0.20
Heavy soil, flat, 2%	0.13 - 0.17
Heavy soil, average, 2-7%	0.18 - 0.25
Heavy soil, steep, 7%	0.25 - 0.35
Streets:	
Asphaltic	0.70 - 0.95
Concrete	0.80 - 0.95
Brick	0.70 - 0.85
Drives and walks	0.75 - 0.85
Roofs:	0.75 - 0.95

Particle Size Analysis Results

Not Applicable

Alternative Risk Analysis

Not Applicable

Sediment Basin Sizing

Not Applicable

project clean water

clean water through local commitment and action

Carlsbad Watershed

Plan

Projects

Stewards



Home

Overview

Planning Efforts

Watersheds

San Juan

Santa Margarita

San Luis Rey

Carlsbad

San Dieguito

Penasquitos

San Diego

Pueblo

Sweetwater

Otay

Tijuana

For Kids

Report Dumping

Search



Hydrologic Unit 904.10 - 904.63

Hydrologic Areas:	Loma Alta 904.1 Buena Vista Creek 904.2 Agua Hedionda 904.3 Encinas 904.4 San Marcos 904.5 Escondido Creek 904.6
Major Water Bodies:	Loma Alta Creek, Buena Vista Creek, Buena Vista Lagoon, Agua Hedionda Creek, Agua Hedionda Lagoon, San Marcos Creek, Batiquitos Lagoon, Escondido Creek, San Elijo Lagoon, and Lake Wolhford
CWA 303(d) List:	Agua Hedionda Creek: manganese, selenium, sulfates, TDS; Agua Hedionda Lagoon: indicator bacteria, sedimentation/siltation; Buena Creek: DDT, nitrate and nitrite, phosphate; Buena Vista Creek: sediment toxicity; Buena Vista Lagoon: indicator bacteria, nutrients, sedimentation/siltation; Cottonwood Creek (San Marcos Creek Watershed): DDT, phosphorous, sediment toxicity; Escondido Creek: DDT, manganese, phosphate, selenium, sulfates, TDS; Loma Alta Slough: eutrophic, indicator bacteria; Pacific Ocean Shoreline (Buena Vista Creek HA, Escondido

	Creek HA, Loma Alta HA, San Marcos HA): indicator bacteria; Reidy Canyon Creek: phosphorous; San Elijo Lagoon: eutrophic, indicator bacteria, sedimentation/siltation; San Marcos Creek: DDE, phosphorous, sediment toxicity; San Marcos Lake: ammonia as nitrogen, nutrients, phosphorous
Major Impacts:	Surface water quality degradation, beach closures, sedimentation, habitat degradation and loss, invasive species, eutrophication
Constituents of Concern:	Indicator bacteria, nutrients, and sediment
Sources / Activities:	Urban runoff, agricultural runoff, sewage spills, livestock, and domestic animals

The Carlsbad Hydrologic Unit (HU) is approximately 210 square miles in area extending from the headwaters above Lake Wolhford in the east to the Pacific Ocean in the west, and from Vista and Oceanside in the north to Solana Beach, Escondido, and the community of Rancho Santa Fe to the south. The cities of Carlsbad, San Marcos, and Encinitas are entirely within this HU. There are numerous important surface hydrologic features within the Carlsbad HU including four unique coastal lagoons, three major creeks, and two large water storage reservoirs. The HU contains four major, roughly parallel hydrologic areas (HAs). From north to south they are the Buena Vista (901.2), the Agua Hedionda (904.3), the Batiquitos (904.5), and the San Elijo (904.6) HAs. Two smaller HAs, the Loma Alta (904.1) and the Canyon de las Encinas (904.4) are also within the Carlsbad HU.

The largest jurisdictions in terms of land area in the Carlsbad HU are the unincorporated San Diego County areas (66 sq. miles), the cities of Carlsbad (39 sq. miles) and San Marcos (24 sq. miles), and an approximately 27 square mile portion of the City of Escondido. The cities of Carlsbad, San Marcos, and Encinitas are located entirely within the HU. Approximately 48% of the Carlsbad HU is urbanized. The dominant land uses are residential (29%), commercial/industrial (6%), freeways and roads (12%), agriculture (12%), and vacant/undeveloped (32%).

The Agua Hedionda, Buena Vista, and San Elijo lagoons are experiencing impairments to beneficial uses due to excessive coliform bacteria and sediment loading from upstream sources. These coastal lagoons represent critical regional resources that provide freshwater and estuarine habitats for numerous plant and animal species. Other water bodies in the Carlsbad HU have been identified as impaired on the California 303(d) list for elevated coliform bacteria including several locations in the Pacific Ocean near creek and lagoon outlets.

The population of the Carlsbad HU is approximately 500,000 residents making it the third most densely populated in San Diego County behind the Pueblo San Diego and the Penasquitos HUs. A high percentage of the undeveloped land is in private ownership and the population of the Carlsbad HU is projected to increase to over 700,000 residents by 2015. Effective planning measures will be needed to

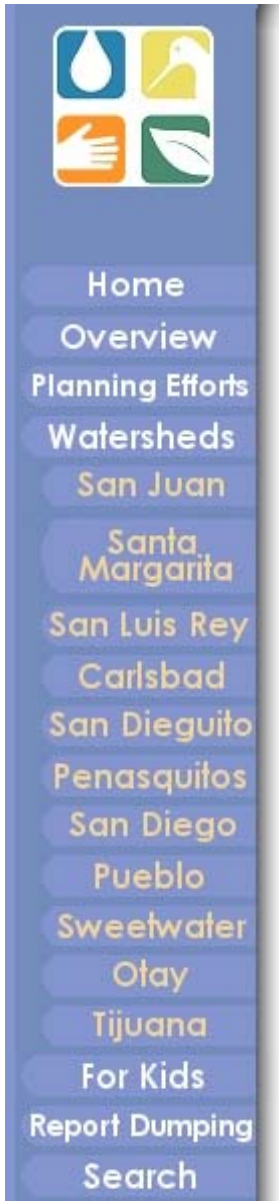

prevent this rapid development from further degrading water quality in this region of San Diego County.

There are many [beneficial water uses within the Carlsbad Watershed](#) as designated in the State Water Resources Control Board's [San Diego Region Basin Plan](#).



project clean water

Leadership, cooperation, and education are the most important tools we have for compelling change.

[PCW Webmaster](#)

2006 CWA SECTION 303(d) LIST OF WATER QUALITY LIMITED SEGMENTS

(Those requiring TMDLS (A), being addressed by USEPA approved TMDLS (B), and being addressed by actions other than TMDLs (C))*

USEPA APPROVAL DATE: JUNE 28, 2007

REGION	TYPE	NAME	CALWATER WATERSHED	POLLUTANT/STRESSOR	POTENTIAL SOURCES	TMDL REQUIREMENT STATUS*	ESTIMATED SIZE AFFECTED	PROPOSED OR USEPA APPROVED TMDL COMPLETION
				PCBs (Polychlorinated biphenyls)		A	0.53 Miles	2019
				Source Unknown				
8	R	Silverado Creek	80112000	Pathogens		A	11 Miles	2019
				Unknown Nonpoint Source				
				Salinity/TDS/Chlorides		A	11 Miles	2019
				Unknown Nonpoint Source				
8	R	Summit Creek	80171000	Nutrients		A	1.5 Miles	2008
				Construction/Land Development				
9	R	Agua Hedionda Creek	90431000	Manganese		A	7 Miles	2019
				Source Unknown				
				Selenium		A	7 Miles	2019
				Source Unknown				
				Sulfates		A	7 Miles	2019
				Source Unknown				
				Total Dissolved Solids		A	7 Miles	2019
				Unknown Nonpoint Source Unknown point source Urban Runoff/Storm Sewers				
9	E	Agua Hedionda Lagoon	90431000	Indicator bacteria		A	6.8 Acres	2006
				Nonpoint/Point Source				
				Sedimentation/Siltation		A	6.8 Acres	2019
				Nonpoint/Point Source				

2006 CWA SECTION 303(d) LIST OF WATER QUALITY LIMITED SEGMENTS

(Those requiring TMDLS (A), being addressed by USEPA approved TMDLS (B), and being addressed by actions other than TMDLs (C))*

USEPA APPROVAL DATE: JUNE 28, 2007

REGION	TYPE	NAME	CALWATER WATERSHED	POLLUTANT/STRESSOR	POTENTIAL SOURCES	TMDL REQUIREMENT STATUS*	ESTIMATED SIZE AFFECTED	PROPOSED OR USEPA APPROVED TMDL COMPLETION
9	R	Aliso Creek	90113000	Indicator bacteria		A	19 Miles	2005
				<i>This listing for indicator bacteria applies to the Aliso Creek mainstem and all the major tributaries of Aliso Creek which are Sulphur Creek, Wood Canyon, Aliso Hills Canyon, Dairy Fork, and English Canyon.</i>				
				Nonpoint/Point Source				
				Unknown point source				
				Urban Runoff/Storm Sewers				
				Phosphorus		A	19 Miles	2019
				<i>This listing for phosphorus applies to the Aliso Creek mainstem and all the major tributaries of Aliso Creek which are Sulphur Creek, Wood Canyon, Aliso Hills Canyon, Dairy Fork, and English Canyon.</i>				
				Unknown Nonpoint Source				
				Unknown point source				
				Urban Runoff/Storm Sewers				
				Toxicity		A	19 Miles	2019
				<i>This listing for toxicity applies to the Aliso Creek mainstem and all the major tributaries of Aliso Creek which are Sulphur Creek, Wood Canyon, Aliso Hills Canyon, Dairy Fork, and English Canyon.</i>				
				Unknown Nonpoint Source				
				Unknown point source				
				Urban Runoff/Storm Sewers				
9	E	Aliso Creek (mouth)	90113000	Indicator bacteria		A	0.29 Acres	2005
				Nonpoint/Point Source				
9	L	Barrett Lake	91130000	Color		A	125 Acres	2019
				Source Unknown				
				Manganese		A	125 Acres	2019
				Source Unknown				
				pH		A	125 Acres	2019
				Source Unknown				

2006 CWA SECTION 303(d) LIST OF WATER QUALITY LIMITED SEGMENTS

(Those requiring TMDLS (A), being addressed by USEPA approved TMDLS (B), and being addressed by actions other than TMDLs (C))*

USEPA APPROVAL DATE: JUNE 28, 2007

REGION	TYPE	NAME	CALWATER WATERSHED	POLLUTANT/STRESSOR	POTENTIAL SOURCES	TMDL REQUIREMENT STATUS*	ESTIMATED SIZE AFFECTED	PROPOSED OR USEPA APPROVED TMDL COMPLETION
				Phosphorus		A	12 Miles	2019
					Unknown Nonpoint Source Unknown point source Urban Runoff/Storm Sewers			
9	R	Oso Creek (at Mission Viejo Golf Course)	90120000	Chloride		A	1 Miles	2019
					Source Unknown			
				Sulfates		A	1 Miles	2019
					Source Unknown			
				Total Dissolved Solids		A	1 Miles	2019
					Source Unknown			
9	L	Otay Reservoir, Lower	91031000	Color		A	1050 Acres	2019
					Source Unknown			
				Iron		A	1050 Acres	2019
					Source Unknown			
				Manganese		A	1050 Acres	2019
					Source Unknown			
				Nitrogen, ammonia (Total Ammonia)		A	1050 Acres	2019
					Source Unknown			
				pH (high)		A	1050 Acres	2019
					Source Unknown			
9	C	Pacific Ocean Shoreline, Aliso HSA	90113000	Indicator bacteria		A	0.65 Miles	2005
					<i>Impairment located at Laguna Beach at Lagunita Place / Blue Lagoon Place, Aliso Beach.</i>			
					Nonpoint/Point Source			

2006 CWA SECTION 303(d) LIST OF WATER QUALITY LIMITED SEGMENTS

(Those requiring TMDLS (A), being addressed by USEPA approved TMDLS (B), and being addressed by actions other than TMDLs (C))*

USEPA APPROVAL DATE: JUNE 28, 2007

REGION	TYPE	NAME	CALWATER WATERSHED	POLLUTANT/STRESSOR	POTENTIAL SOURCES	TMDL REQUIREMENT STATUS*	ESTIMATED SIZE AFFECTED	PROPOSED OR USEPA APPROVED TMDL COMPLETION
9	C	Pacific Ocean Shoreline, Buena Vista Creek HA	90421000	Indicator bacteria		A	1.2 Miles	2008
				<i>Impairment located at Buena Vista Creek, Carlsbad City Beach at Carlsbad Village Drive, Carlsbad State Beach at Pine Avenue.</i>				
				Nonpoint/Point Source				
9	C	Pacific Ocean Shoreline, Dana Point HSA	90114000	Indicator bacteria		A	2 Miles	2005
				<i>Impairment located at Aliso Beach at West Street, Aliso Beach at Table Rock Drive, 1000 Steps Beach at Pacific Coast Hwy (Hospital, 9th Ave), Salt Creek (large outlet), Salt Creek Beach at Salt Creek service road, Salt Creek Beach at Dana Strand Road, and Monarch Beach.</i>				
				Nonpoint/Point Source				
9	C	Pacific Ocean Shoreline, Escondido Creek HA	90461000	Indicator bacteria		A	0.44 Miles	2008
				<i>Impairment located at San Elijo Lagoon outlet.</i>				
				Nonpoint/Point Source				
9	C	Pacific Ocean Shoreline, Imperial Beach Pier	91010000	PCBs (Polychlorinated biphenyls)		A	0.42 Miles	2019
				Source Unknown				
9	C	Pacific Ocean Shoreline, Laguna Beach HSA	90112000	Indicator bacteria		A	1.8 Miles	2005
				<i>Impairment located at Main Laguna Beach, Laguna Beach at Ocean Avenue, Laguna Beach at Laguna Avenue, Laguna Beach at Cleo Street, Arch Cove at Bluebird Canyon Road, Laguna Beach at Dumond Drive.</i>				
				Nonpoint/Point Source				
9	C	Pacific Ocean Shoreline, Loma Alta HA	90410000	Indicator bacteria		A	1.1 Miles	2008
				<i>Impairment located at Loma Alta Creek Mouth.</i>				
				Nonpoint/Point Source				

2006 CWA SECTION 303(d) LIST OF WATER QUALITY LIMITED SEGMENTS

(Those requiring TMDLS (A), being addressed by USEPA approved TMDLS (B), and being addressed by actions other than TMDLs (C))*

USEPA APPROVAL DATE: JUNE 28, 2007

REGION	TYPE	NAME	CALWATER WATERSHED	POLLUTANT/STRESSOR	POTENTIAL SOURCES	TMDL REQUIREMENT STATUS*	ESTIMATED SIZE AFFECTED	PROPOSED OR USEPA APPROVED TMDL COMPLETION
9	C	Pacific Ocean Shoreline, Lower San Juan HSA	90120000	Indicator bacteria		A	1.2 Miles	2008
				<i>Impairment located at North Beach Creek, San Juan Creek (large outlet), Capistrano Beach, South Capistrano Beach at Beach Road.</i>				
				Nonpoint/Point Source				
9	C	Pacific Ocean Shoreline, San Clemente HA	90130000	Indicator bacteria		A	3.7 Miles	2005
				<i>Impairment located at Poche Beach (large outlet), Ole Hanson Beach Club Beach at Pico Drain, San Clemente City Beach at El Portal St. Stairs, San Clemente City Beach at Mariposa St., San Clemente City Beach at Linda Lane, San Clemente City Beach at South Linda Lane, San Clemente City Beach at Lifeguard Headquarters, Under San Clemente Municipal Pier, San Clemente City Beach at Trafalgar Canyon (Trafalgar Ln.), San Clemente State Beach at Riviera Beach, San Clemente State Beach at Cypress Shores.</i>				
				Nonpoint/Point Source				
9	C	Pacific Ocean Shoreline, San Diego HU	90711000	Indicator bacteria		A	0.37 Miles	2005
				<i>Impairment located at San Diego River Mouth (aka Dog Beach).</i>				
				Nonpoint/Point Source				
9	C	Pacific Ocean Shoreline, San Dieguito HU	90511000	Indicator bacteria		A	0.86 Miles	2005
				<i>Impairment located at San Dieguito Lagoon Mouth, Solana Beach.</i>				
				Nonpoint/Point Source				
9	C	Pacific Ocean Shoreline, San Joaquin Hills HSA	90111000	Indicator bacteria		A	0.63 Miles	2005
				<i>Impairment located at Cameo Cove at Irvine Cove Dr./Riviera Way, Heisler Park-North</i>				
				Unknown Nonpoint Source				
				Unknown point source				
				Urban Runoff/Storm Sewers				
9	C	Pacific Ocean Shoreline, San Luis Rey HU	90311000	Indicator bacteria		A	0.49 Miles	2005
				<i>Impairment located at San Luis Rey River Mouth.</i>				
				Nonpoint/Point Source				

2006 CWA SECTION 303(d) LIST OF WATER QUALITY LIMITED SEGMENTS

(Those requiring TMDLS (A), being addressed by USEPA approved TMDLS (B), and being addressed by actions other than TMDLs (C))*

USEPA APPROVAL DATE: JUNE 28, 2007

REGION	TYPE	NAME	CALWATER WATERSHED	POLLUTANT/STRESSOR	POTENTIAL SOURCES	TMDL REQUIREMENT STATUS*	ESTIMATED SIZE AFFECTED	PROPOSED OR USEPA APPROVED TMDL COMPLETION
9	C	Pacific Ocean Shoreline, San Marcos HA	90451000	Indicator bacteria <i>Impairment located at Moonlight State Beach.</i>		A	0.5 Miles	2005
					Nonpoint/Point Source			
9	C	Pacific Ocean Shoreline, Scripps HA	90630000	Indicator bacteria <i>This listing for indicator bacteria only applies to the Childrens Pool Beach area of this ocean shoreline segment.</i>		A	3.9 Miles	2019
					Nonpoint/Point Source			
9	C	Pacific Ocean Shoreline, Tijuana HU	91111000	Indicator bacteria <i>Impairment located from the border, extending north along the shore.</i>		A	3 Miles	2010
					Nonpoint/Point Source			
9	R	Pine Valley Creek (Upper)	91141000	Enterococcus		A	2.9 Miles	2010
					Concentrated Animal Feeding Operations (permitted, point source) Grazing-Related Sources Transient encampments			
				Phosphorus		A	2.9 Miles	2019
					Source Unknown			
				Turbidity		A	2.9 Miles	2019
					Source Unknown			
9	R	Pogi Canyon Creek	91020000	DDT		A	7.8 Miles	2019
					Source Unknown			
9	R	Prima Deshecha Creek	90130000	Phosphorus		A	1.2 Miles	2019
					Unknown Nonpoint Source Unknown point source Urban Runoff/Storm Sewers			

Post-Construction Water Balance Calculator

Not Applicable

Appendix V
Construction Materials

Appendix V List of Potential Pollutant Sources

Activity	Typical Materials
Asphalt Work	Asphalt (conventional and rubberized) Cold mix Asphalt emulsion Asphalt releases – Monocyclic Terpet Liquid asphalt Aluminate Aluminum sulfate Chip seal, seal coat, tack coat, slurry seal or fog seal
Concrete Work	Concrete curing compound – resin based “Monkey blood” (a retardant compound used for concrete curing) Arbitolor Arabitol (1,2,3,4,5-pentane pentol) pH from concrete sawing or freshly placed or washed off Portland cement products Cement Diesel fuel (sprayed on wooden forms as a non-sticking compound between concrete and wood) Concrete mix Concrete slurry
Cleaning	Various citrus based cleaners Solvents Thinners De-greasers Acids Bases Detergents Trisodium phosphate Sodium Hypochlorite
Vehicle and Equipment	Oil, Grease, Fuel Grease Coolant/antifreeze Diesel Gasoline Lubricants Hydraulic and/or brake fluid Adhesives (glues, caulk, sealants)
Pipe Work	Pipe joint compound ABS and PVC primers Chlorine – water line flushing disinfection

Appendix V List of Potential Pollutant Sources

Activity	Typical Materials
Painting	Paints Thinners Mineral spirits Latex paint (propylene glycol) Epoxy Silicone
Electrical Work (Materials and Equipment)	Wooden electrical utility poles Electrical transformers and other electrical equipment Pole anchors Guy wires Conductor cable Stub supports Electrical distribution wire
Gas Work (Material and Equipment)	Poly pipe Steel pipe Pipe wrap primer Pipe wrap Pipe pillows Pipe skids or blocks Welding rods Miscellaneous steel fittings Metal and plastic pipelines Valves, pressure regulators Cable and conduit
Landscaping	Herbicides Pesticides Fertilizers Mulch Compost
Brick Work	Etching compounds Acid wash of brick work

Appendix V List of Potential Pollutant Sources

Activity	Typical Materials
Soil Stabilization	Wood fiber mulch Compost Wood and bark chips Straw mulch Emulsified asphalt Lime Plant gums Bonded fiber matrix Coconut fiber Paper mulch Grass Various proprietary products
Dust Palliatives	EnviroKleen Soil Sement PX-300
Woodwork	Lumber treatment/ preservative Water sealants Stains Sawdust
Structural finishing	Plaster Fire retardants Epoxies Paints (see painting) Tar Urethane

Appendix VI

Construction BMP Manual

MANUAL



WATER QUALITY CONSTRUCTION BEST MANAGEMENT PRACTICES MANUAL

Prepared for:

Sempra Energy Utilities
101 Ash Street
San Diego, CA 92101-3017

URS Project No. 27644947.03B00

December 2002

This page intentionally left blank.

Table of Contents

BMP Program Overview.....	1
BMP Selection and Implementation.....	3
BMP Details.....	9
Sediment Controls.....	11
Waste Management and Material Controls.....	29
Non-Storm Water Discharge Controls.....	39
Erosion Control and Soil Stabilization.....	51

Tables

Table 1	Best Management Practice Selection and Sequencing Guide.....	5
Table 2	Best Management Practice Selection Worksheet for Utility Activities.....	6

Appendices

Appendix A	Definitions and Acronyms
------------	--------------------------

This page intentionally left blank.

BMP PROGRAM OVERVIEW

Water Quality Construction BMP Manual

The purpose of this Manual is to provide standardized best management practices (BMPs) to reduce or eliminate pollutants in runoff from Sempra Energy Utilities¹ (SEU) construction projects for water quality protection. This Manual applies to projects conducted by San Diego Gas and Electric Company (SDG&E), Southern California Gas Company (SCG) (hereon known as Utilities or Utility), and their contractors. The utilities service area encompasses 23,000 square miles of diverse terrain throughout most of Central and Southern California, from Visalia to the Mexican border. Utility projects within the service area are conducted in more than 530 communities and in over 200 municipal jurisdictions. Many of these projects throughout the service area are subject to a variety of National Pollutant Discharge Elimination System (NPDES) permits.

Because of the breadth of jurisdictions and applicable permits that apply to utility projects, this Manual has been developed to provide a consistent approach to water quality management to be applied by the utilities and their contractors throughout their service areas. Most construction projects performed by the utilities and their contractors are linear pipeline or electric installations, which are usually short term, fast moving, and are low impact on narrow corridor sections of land. Many of the BMPs presented in this Manual have used the best and most practical pollution prevention features from several sources such as State of California and Caltrans BMPs that integrate well into our unique utility construction activities.

This Manual is organized into three main sections: BMP Program Overview; BMP Selection and Implementation; and BMP Details. The BMP Details section is divided into four functional BMP categories, 1-Sediment Controls, 2-Waste and Materials Management Controls, 3-Non-Storm Water Discharge Controls and 4-Erosion Control and Soil Stabilization. Within each of these categories, specific information, including “When” and “How” to implement the BMP, plus Maintenance and Inspection information are provided for each BMP. Pictures and diagrams are also provided on several BMPs for easy reference.²

The Manual is a tool designed to assist with the identification of BMPs appropriate for use on a specific site or project. The Manual provides guidance to SEU in their support for water quality goals and meeting regulatory requirements. The BMP selection process provides users with guidance for typical BMPs that may apply to standard SEU construction projects. During BMP selection, the users of this Manual should take into account the benefits and limitations of each of the BMPs considered in the context of the site conditions. Finally, BMP success is contingent not only on appropriate design and implementation, but on the coordination and communication between the designers, engineers, and the field construction teams.

Utility Type Projects

Most Utility projects are very different from commercial or residential developments, building sites, and Caltrans projects. Utility projects are smaller, short term, long and thin, impacting narrow corridors of land. Utility projects are constantly moving or progressing along the route

¹ Sempra Energy Utilities is composed of San Diego Gas & Electric Company and Southern California Gas Company.

² Photographs provided in this Manual have been obtained from URS Corp., Great Circle Int'l, LLC, and Caltrans.

BMP PROGRAM OVERVIEW

and thus have minimal exposure of soil or transportable materials to storm water at any one time. Often, utility projects are in the Right-of-Ways of streets or along utility corridors that must be maintained to ensure safe access to electric and gas lines. BMPs usually are only in place for a few days or even hours. Therefore, BMPs will typically be implemented just prior to a forecasted storm event.

BMP Field Guide

The BMP Field Guide is a separate document developed from the Water Quality BMP Manual that contains the condensed BMPs and supporting information. The Field Guide was designed to be a “pocket sized” reference to the BMP Manual. The primary audience for the Field Guide is the SEU Construction and Maintenance crews who perform operations and activities within the utility service territory.

Training Program

The importance of training and of integrating the elements of employee and contractor training for pollution prevention controls into a comprehensive training program is part of the Utilities overall Water Quality Pollution Prevention Program. All applicable company employees and contractors hired by the company have the responsibility to comply with environmental laws, rules, and regulations. Training for the prevention of environmental related incidents is conducted for applicable employees who perform any operation or activity that has the potential to cause a pollutant to be released into the environment. Records are maintained as to when employees have received this training and instruction. Verification of contractor training should also be obtained.

Applicable employees should know and contact their local Environmental Representatives for support and guidance on any aspects of the Training Program.

BMP SELECTION AND IMPLEMENTATION

General Protocol

To select BMPs that are appropriate for a given project, the following steps should be followed:

Step 1 – Identify Activities, Pollutants and Issues of Concern

Step 2 – Evaluate Site Conditions and Select BMPs

Step 3 – Implement, Monitor, and Maintain the BMPs

Step 1 – Identify Activities, Pollutants, and Issues of Concern

The first step in BMP selection is to identify the project activities, the potential pollutants of concern and the local issues of concern. Project activities may include saw cutting, trenching, excavation, stockpiling of soil, grading and grubbing, access road maintenance, paving, or other activities with the potential to impact storm water and non-storm water discharges. Pollutants of concern may include sediment; petroleum products such as fuel, oil, and grease from vehicle and equipment operation; paving materials such as concrete and asphalt components; other materials used or stored on site, such as pesticides, herbicides, fertilizer, detergents, paint, adhesives, and solvents; and project wastes such as litter, debris, hazardous wastes, and liquid wastes. The local issues of concern may include:

- Proximity to sensitive receiving waters (environmentally sensitive areas or Clean Water Act Section 303(d) listed water bodies, examples: Santa Monica Bay, San Diego Bay).
- Local regulatory requirements influencing BMP selection, or timing of BMP implementation.

Step 2 – Evaluate Site Conditions and Select BMPs

To assist in BMP selection, this Water Quality Construction BMP Manual presents BMPs that are anticipated to be most applicable to utility construction projects. Utility projects are unique in that they are typically very short-term and fast moving, have minimal exposure of soil or transportable materials at any one time to storm water. The selector should consider any project-specific requirements or factors such as BMP effectiveness, cost, availability, feasibility, and suitability for the site. For example, important site conditions to consider include the amount of soil disturbance, anticipated weather conditions, soil type and erodibility, flow path length, and slope of exposed soil. Selected BMPs can and should be modified to suit the scope of the project and site conditions. Table 1 presents guidelines for BMP selection and implementation at a construction site. Table 2 presents a BMP selection worksheet for utility activities. These implementation guidelines and selection worksheet can be used to select BMPs for a specific project. Finally, a selector may discover a better BMP for their situation not listed in Tables 1 or 2. Environmental Services encourages creative and practical pollution prevention techniques. These new techniques can be shared with others to support the water quality goals of the region.

Step 3 – Implement, Monitor, and Maintain the BMP System

It is important that selected BMPs be implemented in a sequence that maximizes protection of water quality, be monitored regularly for effectiveness and be maintained as necessary throughout the project. Most BMPs will only be implemented when needed, and/or when a storm

BMP SELECTION AND IMPLEMENTATION

event is forecasted or occurs. Table 1 presents a suggested schedule for BMP implementation and sequencing. Steps in this schedule should be reviewed for each project as applicable. All BMPs should be monitored and inspected regularly and particularly before, and after rain events. BMPs should be maintained during a project in accordance with the procedures outlined in the BMP Details Section.

BMP Installation Contractors

This Water Quality Construction BMP Manual identifies some utility activities and operations that may require outside contractors to install the applicable BMPs. However, the utility crews will implement most BMPs. Most types of BMP materials are readily available from local suppliers.

BMP SELECTION AND IMPLEMENTATION

Table 1
BMP SELECTION AND SEQUENCING GUIDE

Step No.	Description	What to Do	BMP Options
1.	Before Construction	Before construction, evaluate, mark, and protect important trees and associated rooting zones, unique areas (e.g., wetlands), and other areas to be preserved, especially in perimeter areas.	4-01, other user-defined BMPs
2.	Site Access Areas (construction entrances, roadways equipment parking areas)	Stabilize site entrances and access roads if applicable prior to earthwork.	1-07, other user-defined BMPs
3.	Storm Drain Inlet Protection	Install inlet protection at down-gradient inlets that project runoff/tracking might impact.	1-06, other user-defined BMPs
4.	Perimeter Sediment Control	Install perimeter sediment controls (silt fence, fiber rolls, etc.) as applicable prior to land disturbing activities. Install additional runoff control measures during construction as needed.	1-02, 1-03, 1-04, 1-05, other user-defined BMPs
5.	Material and Waste Storage Areas	Prepare staging areas, material storage and disposal areas as applicable. Grade to reduce run-on and runoff, install perimeter controls, obtain clean-up materials, plastic covers for stockpiles, etc. prior to storing materials on site.	2-01 through 2-08, 1-08, other user-defined BMPs
6.	Earthwork (trenching, excavation, grading, surface roughening, grubbing)	Begin excavation, trenching, or grading after installing applicable sediment and runoff control measures. Install additional control measures as work progresses as needed.	through 1-09, other user-defined BMPs
7.	Surface Stabilization (temporary and permanent seeding, mulching)	Apply temporary or permanent soil stabilization measures as applicable on all disturbed areas where work is delayed or completed.	4-01 through 4-08, other user-defined BMPs
8.	Construction and Paving (install utilities, buildings, paving)	Implement applicable control practices as work takes place.	3-01 through 3-10, other user-defined BMPs
9.	Final Stabilization and Landscaping	Stabilize open areas as applicable. Remove temporary control measures and install final stabilization controls appropriately (topsoil, trees and shrubs, permanent seeding, mulching, sodding, riprap)	3-07, 4-03, 4-04, other user-defined BMPs

BMP SELECTION AND IMPLEMENTATION

**Table 2
BMP SELECTION WORKSHEET FOR UTILITY ACTIVITIES**

Sempra Energy Utility BMP No.	BMP Options	Construction				Maint. And Repair			
		Potholing	Overhead Electric	Underground Electric	Underground Gas	Gen. Maint. and Repair	Inspect and Repair	Tree Trimming	Veg. Control
Section 1 Sediment Controls									
Choose from one or more of the following BMP options when applicable:									
BMP-1-01	Scheduling								
BMP-1-02	Silt Fence								
BMP-1-03	Fiber Rolls								
BMP-1-04	Gravel Bag Berm								
BMP-1-05	Sand bag Barrier								
BMP-1-06	Storm Drain Inlet Protection								
BMP-1-07	Tracking Controls								
BMP-1-08	Stockpile Management								
Other-User Defined	BMP Description:								
Section 2 Waste Management and Material Controls									
Choose from one or more of the following BMP options when applicable:									
BMP-2-01	Material Delivery and Storage								
BMP-2-02	Material Use								
BMP-2-03	Spill Control								
BMP-2-04	Solid Waste Management								
BMP-2-05	Hazardous Materials/Waste Management								
BMP-2-06	Contaminated Soil Management								
BMP-2-07	Sanitary/Septic Waste Management								
BMP-2-08	Liquid Waste Management								
Other-User Defined	BMP Description:								
Section 3 Non-Storm Water Discharge Controls									
Choose from one or more of the following BMP options when applicable:									
BMP-3-01	Dewatering Operations								
BMP-3-02	Paving Operations								

BMP SELECTION AND IMPLEMENTATION

**Table 2 (continued)
BMP SELECTION WORKSHEET FOR UTILITY ACTIVITIES**

Sempra Energy Utility BMP No.	BMP Options	Construction				Maint. And Repair			
		Potholing	Overhead Electric	Underground Electric	Underground Gas	Gen. Maint. and Repair	Inspect and Repair	Tree Trimming	Veg. Control
Section 3 Non-Storm Water Discharge Controls (Continued)									
BMP-3-03	Vehicle and Equipment Washing								
BMP-3-04	Vehicle and Equipment Fueling								
BMP-3-05	Concrete/Coring/Sawcutting and Drilling Waste Management								
BMP-3-06	Dewatering Utility Substructures and Vaults								
BMP-3-07	Vegetation Management including Mechanical and Chemical Weed Control								
BMP-3-08	Over-Water Protection								
BMP-3-09	Removal of Utility Location/Mark-Out Paint								
Other-User Defined	BMP Description:								
Section 4 Erosion Control and Soil Stabilization									
Choose from one or more of the following BMP options when applicable:									
BMP-4-01	Preservation of Existing Vegetation								
BMP-4-02	Temporary Soil Stabilization								
BMP-4-03	Hydraulic Mulch								
BMP-4-04	Hydroseeding								
BMP-4-05	Soil Binders								
BMP-4-06	Straw Mulch								
BMP-4-07	Geotextiles, Plastic Covers and Erosion Control Blankets/Mats								
BMP-4-08	Dust (Wind Erosion) Control								
Other-User Defined	BMP Description:								

BMP SELECTION AND IMPLEMENTATION

This page intentionally left blank.

BMP DETAILS

This Section provides details for the selection and implementation of BMPs for the most common utility construction activities. Once the BMP objectives are defined, it is necessary to identify the category or categories of BMPs that are best suited to meet each objective. A category is a grouping of BMPs related in how they prevent pollution. The four categories are:

- Section 1 – Sediment Controls
- Section 2 – Waste Management and Material Controls
- Section 3 – Non-Storm Water Discharge Controls
- Section 4 – Erosion Control and Soil Stabilization

BMP DETAILS

This page intentionally left blank.

BMP DETAILS



Section 1 – Sediment Controls

Sediment particles (soil/dust) from utility activities can be transported to a different location by wind or water flow. Once these particles have become detached, they are considered a pollutant. Sediment Controls include any method that traps the soil particles after they have been detached and moved by wind or water. Sediment Controls are usually passive systems that rely on filtering or settling the particles out of the water or wind that is transporting them. The sediment that has accumulated by the BMPs can be disposed of as excess soil on the construction site. Sediment Controls presented in this Manual include the following:

- BMP 1-01 Scheduling
- BMP 1-02 Silt Fence
- BMP 1 03 Fiber Rolls
- BMP 1-04 Gravel Bag Berm
- BMP 1-05 Sand bag Barrier
- BMP 1-06 Storm Drain Inlet Protection
- BMP 1-07 Tracking Controls
- BMP 1-08 Stockpile Management

BMP DETAILS

This page intentionally left blank.

When Scheduling must be considered for applicable projects year-round.

How Use the following measures as applicable:

- Consider scheduling major soil disturbing activities or activities near environmentally sensitive areas (e.g., adjacent to water bodies) during the non-rainy season.
- Monitor the weather forecast for seasonable and unseasonable rain events. Weather information is available from the following sources:
 - San Diego: www.wrh.noaa.gov/sandiego/index.shtml or (619) 289-1212
 - Los Angeles/Oxnard: www.nwsla.noaa.gov or (805) 988-6610
 - AccuWeather: www.accuweather.com
- Always be prepared to deploy erosion and sediment control and soil stabilization BMPs. Off site sediment discharges can occur during the non-rainy season because of unseasonable rainfall, wind, non-storm water discharges, and vehicle tracking and must be prevented.

PLUS, DURING THE RAINY SEASON (October 1–May 1, Desert regions differ August 1- May 30)

- Sequence work to minimize soil-disturbing activities during forecasted rain events.
- Limit disturbed soil area to the amount of acreage that can be protected prior to a forecasted rain event.
- Stabilize disturbed soil areas as soon as practical, and, at a minimum, prior to a forecasted rain event.
- Protect environmentally sensitive areas, such as drainage channels, streams, and natural watercourses.
- When rainfall is forecast, adjust the construction schedule to implement soil stabilization and sediment controls on all disturbed areas prior to the onset of rain.

Maintenance and Inspection

- Review applicable scheduling and sequencing of construction activities throughout the project to minimize the amount or time that soil is exposed and the total area of exposed soil.
- Inspect erosion and sediment controls prior and after each storm event, and routinely throughout the rainy season (to be consistent with all the other BMPs).

Pictures



When Silt fences are temporary linear sediment barriers made of permeable fabric designed to intercept and slow the flow of sediment-laden sheet flow runoff. Silt fences allow sediment to settle from runoff before water leaves the construction site.

Silt fences are placed:

- Below the toe of exposed and erodible slopes.
- Down-slope of exposed soil areas.
- Around temporary stockpiles.
- Along streams and channels.
- Along the perimeter of a project.

- How**
- Construct silt fences with a setback of at least 3 feet from the toe of a slope in areas suitable for temporary ponding or deposition of sediment. Where a 3-foot setback is not practicable, construct as far from the toe of the slope as practicable.
 - Generally, silt fences shall be used in conjunction with soil stabilization source controls up slope to provide effective control, particularly for slopes adjacent to water bodies or Environmentally Sensitive Areas.
 - Construct the length of each reach (length of fence) so that the change in base elevation along the reach does not exceed 1/3 the height of the barrier; each reach should not exceed 500 feet. The last 6 feet of the reach should be turned upslope.
 - The maximum length of slope draining to the silt fence should be 200 ft or less.
 - Excavate a trench to place the bottom of the silt fence into that is not wider or deeper than necessary.
 - Key-in, or bury the bottom of silt fence fabric in trench and tamp into place. If it is not feasible to trench along the slope contour, use sand bags or backfilling to key in the bottom of the fabric.
 - Install fence post at least 12 inches below grade on down slope side of trench.
 - **Silt fences should not be considered for installation below slopes steeper than 1:1 (vertical : horizontal) or that contain a high number of rocks or loose dirt clods.**

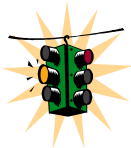

Maintenance and Inspection

- Repair or replace split, torn, slumping, undercut or weathered fabric.
- Inspect silt fences prior and after each storm event, and routinely throughout the rainy season.
- Remove accumulated sediment when it reaches one third (1/3) of the barrier height. Removed sediment shall be incorporated in the project at appropriate locations or disposed of at an SCG/SDG&E-approved site
- Silt fences that are damaged and become unsuitable for the intended purpose shall be removed and disposed of and replaced with new silt fence barriers.
- Remove silt fence when no longer needed. Fill and compact post-holes and anchorage trench, remove sediment accumulation, and grade fence alignment to blend with adjacent ground.

Pictures



Silt fence installed at the toe of an erodible slope. Note use is combined with fiber rolls and serves as perimeter control.



When A fiber roll consists of straw, flax or other similar materials that are rolled and bound into a tight roll that is generally placed on the face of slopes at regular intervals to intercept runoff, reduce flow velocity, release the runoff as sheet flow and provide the removal of sediment.

- May be used along the top, face and at grade breaks of exposed and erodible slopes to shorten slope length and spread runoff as sheet flow.
- Fiber rolls may be used as check dams.
- Fiber Rolls can also be used where flows are moderately concentrated, such as ditches, swales, and storm drain inlets (Storm Drain Inlet Protection to divert and/or detain flows.).
- Fiber rolls are appropriate for perimeter site control or along streams, channels, storm drain inlets, or around stockpiles to intercept sediment laden storm water and non-storm water runoff.

How Installation

- Locate fiber rolls on level contours spaced 8 to 20 feet apart along the face of the slope.
- Its best to stake fiber rolls into a 2 to 4 inch deep trench.
- Drive stakes into fiber rolls at a minimum of 4-foot intervals
- If more then one fiber roll is placed in a row, fiber rolls should be butted together and not overlapped.

Removal

- If used on slopes, fiber rolls are typically left in place.
- If used as Storm Drain Inlet Protection, stockpile control, or other temporary control measures, the fiber rolls should be removed at the completion of the construction project.
- If fiber rolls are removed, collect and dispose of fiber roll and sediment accumulation as appropriate. Fill and compact holes, trenches, depressions, or any other ground disturbance to blend with adjacent ground.

Maintenance and Inspection

- Repair or replace spilt, torn, unraveling, or slumping fiber rolls.
- Inspect fiber rolls if rain is forecasted, perform maintenance as needed.
- Inspect fiber rolls prior and after each storm event, and routinely throughout the rainy season.

Pictures

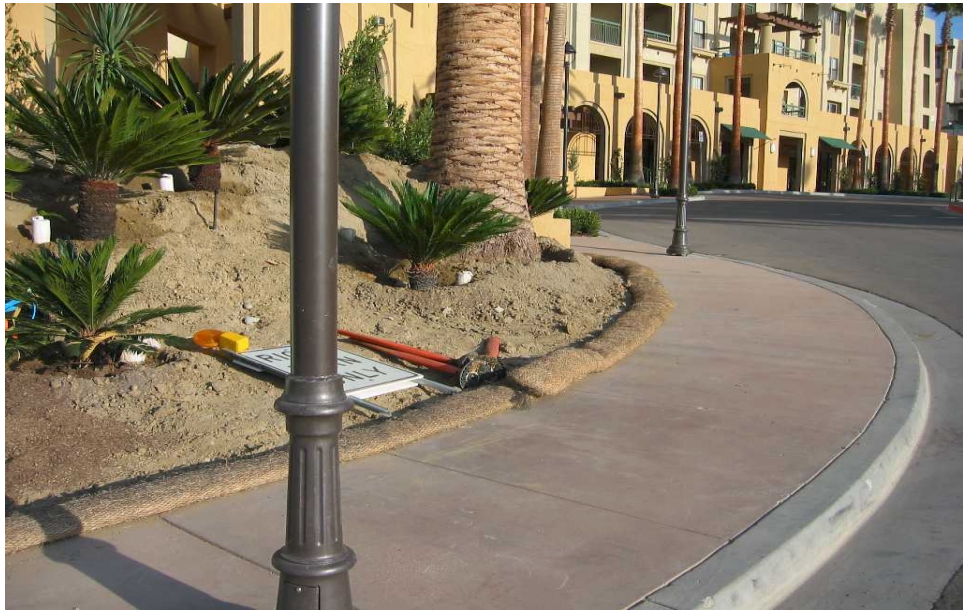

Fiber rolls as perimeter control



Fiber roll installation on the face of a slope.



- When** A gravel bag berm consists of a single row of gravel bags that are installed end-to-end to form a barrier across a slope to intercept runoff, reduce its flow velocity, release the runoff as sheet flow and provide some sediment removal. Gravel bags can also be used where flows are moderately concentrated, such as ditches, swales, and storm drain inlets (Storm Drain Inlet Protection to divert and/or detain flows). Gravel bag berms are appropriate for perimeter site control or along streams, channels, storm drain inlets, or around stockpiles to intercept sediment laden storm water and non-storm water runoff. Use gravel bag berms:
- Where it is desirable to filter sediment in runoff. Note that gravel bag berms are generally more permeable than sand bags. Sand bag barriers should be used in cases where it is desirable to block and pond flows (e.g., for containment of non-storm water flows).
 - Along the face and at grade breaks of exposed and erodible slopes to shorten slope length and spread runoff as sheet flow.
 - On a project-by-project basis to maximize effectiveness.
 - Gravel bags may be implemented with other BMPs to maximize sediment containment.
- How**
- When used as a linear control for sediment removal:
 - Install along a level contour.
 - Turn ends of gravel bag row up slope to prevent flow around the ends.
 - Generally, gravel bag barriers are used in conjunction with temporary soil stabilization controls up slope to provide effective control.
 - When used for concentrated flows:
 - Stack gravel bags to required height. When the height requires 3 rows or more, use a pyramid approach.
 - Upper rows of gravel bags shall overlap joints in lower rows.
 - Construct gravel bag barriers with a setback of at least 3 feet from the toe of a slope. Where a 3-foot setback is not practicable, construct as far from the toe of the slope as practicable.
- Maintenance and Inspection**
- Inspect gravel bag berms prior and after each storm event, and routinely throughout the rainy season.
 - Reshape or replace gravel bags as needed.
 - Repair washouts or other damages as needed.
 - Inspect gravel bag berms for sediment accumulations and remove sediments when accumulation reaches one-third of the berm height. Removed sediment shall be incorporated in the project at appropriate locations or disposed of at an SCG/SDG&E-approved site.
 - Remove gravel bag berms when no longer needed. Remove sediment accumulation, and clean, re-grade, and stabilize the area. Removed sediment shall be incorporated in the project at appropriate locations or disposed of at an SCG/SDG&E-approved site.

SEDIMENT CONTROLS

Gravel Bag Berm



Pictures



Gravel bags and fiber rolls used as a perimeter sediment control system.



Gravel bags used as perimeter control.



When A sand bag barrier is a temporary linear sediment barrier consisting of stacked sand bags, designed to intercept and slow sediment-laden storm water and non-storm water runoff. Sand bag barriers allow sediment to settle from runoff before water leaves the construction site.

- Sand bags can be used where flows are moderately concentrated, such as ditches, swales, and storm drain inlets to divert and/or detain flows. See BMP on Storm Drain Inlet Protection.
- To divert or direct flow away from disturbed slopes or create a temporary sediment basin.
- During construction activities in streambeds when the contributing drainage area is 1 to 5 acres.
- To capture and detain non-storm water flows until proper cleaning operations occur.
- When site conditions or construction sequencing require adjustments or relocation of the barrier to meet changing field conditions and needs during construction.
- To temporarily close or continue broken, damaged or incomplete curbs.

Sand bag barriers are used:

- Where it is desirable to block and pond flow (e.g., for containment of non-storm water flows). Use caution when using sand bag barriers in traffic areas or other areas where potential flooding is not desirable.
- Along the perimeter of a site, vehicle and equipment fueling and maintenance areas, chemical storage areas, or stockpiles.
- Below the toe or down slope of exposed and erodible slopes.
- Parallel to streams, channels, and roadways.
- Across channels to serve as a barrier for utility trenches or provide a temporary channel crossing for construction equipment, or to reduce stream impacts.

- How**
- When used as a linear control for sediment removal:
 - Install along a level contour.
 - Turn ends of sand bag row up slope to prevent flow around the ends.
 - Generally, sand bag barriers shall be used in conjunction with temporary soil stabilization controls up slope to provide effective control.
 - When used for concentrated flows:
 - Stack sand bags to required height. When the required height is three rows or more, use a pyramid approach. Upper rows of sand bags shall overlap joints in lower rows.
 - Construct sand bag barriers with a setback of at least 3 feet from the toe of a slope. Where a 3-foot setback is not practicable, construct as far from the toe of the slope as practicable.

SEDIMENT CONTROLS

Sand Bag Barrier



Maintenance and Inspection

- Inspect sand bag barriers prior and after each storm event, and routinely throughout the rainy season.
- Repair washouts or other damages as needed, or as directed by the projects Environmental Representative.
- Inspect sand bag barriers for sediment accumulations and remove sediments when accumulation reaches one-third the barrier height.
- Remove sand bags when no longer needed. Remove sediment accumulation, and clean, re-grade, and stabilized the area. Incorporate removed sediment at appropriate project locations or dispose of at an SCG/SDG&E-approved site.

Pictures



Sand bags used as perimeter control.

SEDIMENT CONTROLS

Storm Drain Inlet Protection



- When** A device used at storm drain inlets to protect against the discharge of sediment-laden storm water and non-storm water runoff from construction activities. The device develops a pond behind it giving the sediment time to settle out before discharge to the storm drain. Do not construct such that runoff will result in:
- Ponding into road traffic or onto erodible surfaces or slopes, or
 - Overflowing onto the sidewalk
- This BMP is required on all construction projects where sediment laden surface runoff may enter a storm drain inlet and watercourses.
- How**
- Identify downstream storm drain inlets that have the potential to runoff from construction activities.
 - Where a storm drain inlet is on or at the bottom of a slope, a series of small check dams (i.e., gravel bags) constructed at intervals along the slope may be required to slow the runoff.
 - Select appropriate protection and construct inlet protection based on the configuration of inlets at the site.
- Maintenance and Inspection**
- Inspect inlet protection devices prior and after storm event, and routinely throughout the rainy season.
 - Remove inlet protection devices at the end of the construction period, or when the inlet can no longer be impacted by the project.
 - During inspections:
 - Inspect bags, silt fence, or filter fabric for holes, gashes, and snags.
 - Check gravel bags for proper arrangement and displacement; and
 - Remove the sediment behind the barrier when it reaches one-third the height of the barrier. Removed sediment should be incorporated in the project or disposed of at an approved Utility disposal site.

Pictures

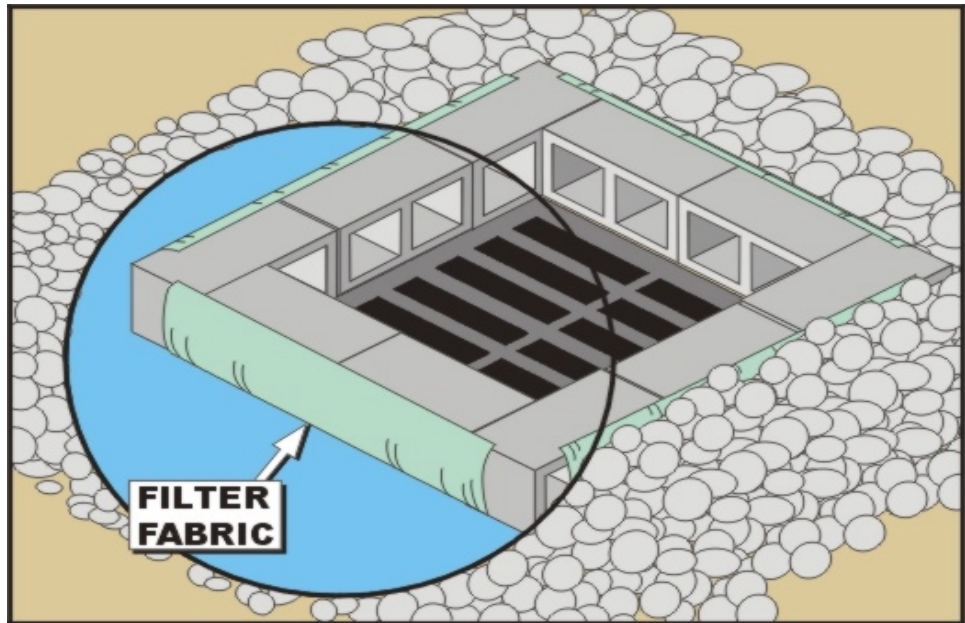

Block and gravel-type inlet protection.



Inlet protection that blocks flow is good for preventing non-storm water discharges from entering the drain.

SEDIMENT CONTROLS

Storm Drain Inlet Protection

BMP 1-06 

Pictures
(continued)



Gravel bag inlet protection.



Inlet protection using fiber rolls and filter fabric.



When Tracking controls reduce offsite tracking of sediment and other pollutants by providing a stabilized entrance at defined construction site entrances and exits and/or providing methods to clean-up sediment or other materials to prevent them from entering a storm drain by sweeping or vacuuming.

- Stabilize entrances should be implemented on a project-by-project basis in addition to other BMPs.
- Sweeping or vacuuming should be implemented when sediment is tracked from the project site onto public or private paved roads, typically at points of site exit.
- Use stabilized entrances and/or sweeping at construction sites:
 - where dirt or mud is tracked onto public roads
 - adjacent to water bodies
 - where poor soils are encountered, such as soils containing clay.
 - where dust is a problem during dry weather conditions.

How Stabilized Construction Entrances

- Limit the points of entrance/exit to the construction site by designating combination or single purpose entrances and exits. Require all employees, subcontractors and others to use them. Limit speed of vehicles to control dust.
- Grade each construction entrance/exit to prevent runoff from leaving the construction site.
- Route runoff from stabilized entrances/exits through a sediment-trapping device before discharge.
- Design stabilized entrance/exit to support heaviest vehicles and equipment that will use it.
- Select construction access stabilization (aggregate, asphaltic concrete, concrete) based on longevity, required performance, and site conditions.
- Use of constructed or constructed/manufactured steel plates with ribs for entrance/exit access is allowed.
- If aggregate is selected, place crushed aggregate over geotextile fabric to at least 12 inches deep, or place aggregate to a depth recommended by a geotechnical engineer. A crushed aggregate greater than 3 inches but smaller than 6 inches shall be used.

Street Sweeping and Vacuuming

- Inspect potential sediment tracking locations routinely.
- Visible sediment tracking should be swept or vacuumed as needed. Manual sweeping is appropriate for small jobs.
- Manual sweeping is appropriate for small projects. For larger projects, it is preferred to use sweeping methods that collect removed sediment and material.

If not mixed with debris or trash, incorporate the removed sediment back into the project or dispose of it at an approved disposal site.

SEDIMENT CONTROLS

Tracking Controls



Maintenance and Inspection

Stabilized Construction Entrance

- Inspect routinely for damage and assess effectiveness. Repair if access is clogged with sediment.
- Where tracking has occurred on roadways sweeping should be conducted the same day. Preferably water should not be used to wash sediment off the streets. If water is used, it should be captured preventing sediment-laden water from running off the site.
- Keep all temporary roadway ditches clear.

Street Sweeping and Vacuuming

Inspect inlet and outlet access points routinely and sweep tracked sediment as needed.

Be careful not to sweep up any unknown substance or any object that may be potentially hazardous.

- After sweeping is finished, properly dispose of sweeper wastes.

Pictures



Manufactured metal plates knock dirt off vehicles before exiting a site.

SEDIMENT CONTROLS

Stockpile Management



When Use this BMP when projects require stockpiled soil and paving materials. The stockpile management practices used differ based on forecasted weather or terrain.

- Protection of stockpiles must be implemented whenever there is a potential for transport of materials by a water source (forecast precipitation or any non-storm water runoff).

How

- One or more of the following options may be used to manage stockpiles and prevent stockpile erosion and sediment discharges for stormwater and non-storm water runoff/run-on.

- Stockpile may be returned to the excavation if precipitation is forecast.
- Protect stockpiles from stormwater run-on using a temporary perimeter sediment barrier such as berms, silt fences, fiber rolls, covers, sand/gravel bags, or straw bale barriers, as appropriate.
- Stockpiles may be hauled off or temporarily stored in a protected location off site.
- Keep stockpiles organized and surrounding areas clean.
- Protect storm drain inlets, watercourses, and waterbodies from stockpiles, as appropriate.
- Implement dust control practices as appropriate on all stockpiled material.
- **Stockpiles should be covered, stabilized, or protected with a perimeter sediment barrier prior to the onset of precipitation.**

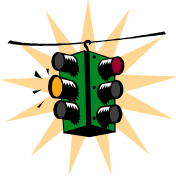

Maintenance and Inspection

Repair and/or replace covers, and perimeter containment structures as needed.

Pictures



Stockpile covered with plastic and secured with large rocks.



Silt fence used for stockpile perimeter control.

BMP DETAILS

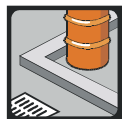

Section 2 – Waste Management and Material Controls

Federal, state and local laws, regulations, ordinances and permits prohibit the discharge of contaminated stormwater to storm drains and surface waters. Transport of sediment, and other pollutants, such as litter, paint, solvents, fuel, lubricants and demolition wastes, can be carried away from a construction site in stormwater. Therefore, BMPs are to be used for those construction activities that could cause pollution to ensure that pollutants are properly managed and are not discharged to storm drains and surface waters.

Waste Management and Materials Controls are source control BMPs that reduce or prevent contact between wastes and/or materials and storm water. Waste Management and Materials Controls presented in this Manual include the following:

- BMP 2-01 Material Delivery and Storage
- BMP 2-02 Material Use
- BMP 2-03 Spill Control
- BMP 2-04 Solid Waste Management
- BMP 2-05 Hazardous Materials/Waste Management
- BMP 2-06 Contaminated Soil Management
- BMP 2-07 Sanitary/Septic Waste Management
- BMP 2-08 Liquid Waste Management

BMP DETAILS

This page intentionally left blank.

WASTE MANAGEMENT AND MATERIAL CONTROLS

Material Delivery and Storage

BMP 2-01

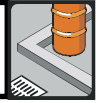

When If it is necessary to store materials at a construction site. This BMP does not apply to materials and supplies stored on trucks that are driven on site and off site daily.

How Use the following measures as appropriate:

- Only store the minimum amount of material that is needed for the job.
- Locate storage areas away from storm drain inlets, drainage systems, and watercourses to prevent storm water run-on from reaching the materials.
- If practical, store materials in enclosed storage containers such as cargo containers.
- Store materials on impervious surfaces or use plastic groundcovers to prevent any spills or leakage from contaminating the ground.
- For known hazardous materials, keep materials covered using plastic or other waterproof materials.
- If necessary provide secondary containment systems around material storage areas to prevent contaminated run-off/run-on from leaving storage area(s).
- Keep adequate supply of spill kit materials nearby.
- Ensure that qualified personnel are available when hazardous materials are delivered to ensure proper delivery and storage in designated area.
- When storage area is no longer needed, return it to original condition.
- Bagged materials such as cold patch, concrete mix, and other materials with the potential to pollute runoff should be placed on pallets and under cover.

Maintenance and Inspection

Repair or replace covers, containment structures, or perimeter controls as needed to ensure proper functioning. Perform routine inspections of designated delivery and storage areas.

Pictures



Materials are covered and neatly stored with a curbed area.



- When** Apply this BMP when the following materials are used or prepared on site:
- Pesticides and herbicides.
 - Fertilizers and soil amendments.
 - Detergents.
 - Petroleum products such as fuel, oil, and grease.
 - Asphalt and other concrete components.
 - Hazardous chemicals such as acids, lime, glues, adhesives, paints, solvents, and curing compounds.
 - Mastic, pipe wrap, primers, and paint.
 - Concrete compounds.
 - Welding material.
 - Other materials that may be detrimental if released to the environment.
- How**
- Reduce or eliminate use of hazardous materials on site when practical. Contact your Environmental Representative for additional information.
 - Empty latex paint and paint cans, used brushes, paint rags, absorbent materials, and drop cloths. When these items are thoroughly dry and are no longer hazardous, may be disposed of with other construction debris.
 - Do not remove the original product label; it contains important safety and disposal information. Use the entire product before disposing of the container.
 - When possible, mix paint indoors, otherwise use secondary containment structures. Do not clean paintbrushes or rinse paint containers into a street, gutter, storm drain, sanitary sewer or watercourse.
 - Dispose of any paint thinners, residue and sludge(s), that cannot be recycled, as hazardous waste. For water-based paint, clean brushes to the extent practical, and rinse into a concrete washout pit or temporary sediment trap. For oil-based paints, clean brushes to the extent practical and filter and reuse thinners and solvents.
 - If possible, recycle residual paints, solvents, non-treated lumber, and other materials.
 - **Do not over-apply fertilizers, pesticides, and soil amendments. Prepare only the amount needed. Strictly follow the recommended usage instructions.**
 - Keep an ample supply of spill clean up material near use areas. Instruct employees in spill clean up procedures.
 - Avoid exposing applied materials to rainfall unless sufficient time has been allowed for them to dry or cure.
 - Hazardous materials use shall also be managed in accordance with the BMP on “Hazardous Materials/Waste Management.”
- Maintenance and Inspection**
- Spot-check employees and contractors regularly throughout the job’s duration to ensure appropriate practices are being employed.

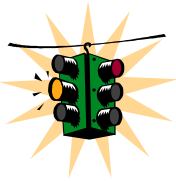



When This best management practice (BMP) applies to all construction sites at all times. Spill control procedures are implemented anytime chemicals and/or hazardous substances are stored. Substances may include, but are not limited to fuels, lubricants, solvents, fertilizers, pesticides, herbicides, soil binders, coolants, paints, and sewage.

To the extent that work can be accomplished safely, spills of materials or chemicals shall be contained and cleaned up immediately.

How Stop the spillage of material if it can be done safely. Clean the contaminated area, and properly dispose of contaminated materials. For all spills notify the project foreman and/or the Environmental Representative. Use the following spill prevention and controls when applicable.

- To the extent that it doesn't compromise clean up activities, spills shall be covered and protected from storm water run-on during rainfall.
- Spills shall not be buried or diluted with wash water.
- Used clean up materials, contaminated materials, and recovered spill material shall be stored and disposed of in accordance with federal, state and local regulations Refer to BMP on "Hazardous Materials/Waste Management").
- Use absorbent materials on spills rather than using water to hose down the spill.
- When water is used for cleaning and decontamination of a spill, the water shall not be allowed to enter storm drain inlets or watercourses, and shall be collected and disposed of properly. Coordinate disposal of these wastes with the Environmental Representative.
- Keep spill cleanup kits in areas where any materials are used and stored.

Maintenance and Inspection

- Perform routine inspections to verify that spill control clean up materials are near material storage, unloading, and use areas.

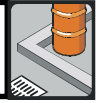

When These BMPs should be used on all construction projects that generate solid waste. Solid wastes may include, but are not limited to concrete, cement, asphalt rubble, masonry brick/block, vegetation debris, steel and scrap metals, pipe and electrical cuttings, non-hazardous equipment parts, Styrofoam, general trash and other materials used to transport and package construction materials.

- How**
- Practice good housekeeping and keep site clean.
 - Use “dry” methods for site clean up such as sweeping, vacuuming and hand pick-up.
 - Designate a waste storage area on site. If a designated waste storage area is not feasible, remove wastes from the site regularly.
 - Prohibit littering by employees, contractors and visitors.
 - Trash receptacles should be available on site and/or on construction vehicles.
 - Protect wastes from being washed away by rainfall, storm water run-on, or other waters (irrigation, water line breaks, etc.).
 - To prevent storm water run-on from contacting stored solid waste (stockpiled materials) use berms, secondary containment, covered dumpsters/roll-offs or other temporary diversion structure or measures.
 - For materials with the potential for spills or leaks, stockpile on impervious surfaces or use plastic groundcovers to prevent spills or leaks from infiltrating the ground.
 - Do not hose out or clean out dumpsters or containers at the construction site.
 - Prevent solid waste and trash from entering and clogging storm drain inlets.
 - As practical, incorporate any removed clean sediment and soil back into the project.
 - Reference BMP on Stockpile Management.

Maintenance and Inspection

- Collect site trash regularly, especially before rainy or windy conditions.
- Perform routine inspections of site, including storage areas, dumpsters, stockpiles and other areas where trash and debris are collected.
- Close trashcan lids and dumpster covers before rainy or windy conditions.

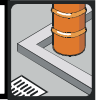

- When** Use this BMP when projects involve the storage and use of hazardous materials, and the generation of waste byproducts, from the following:
- Petroleum products such as oils, fuels, greases, cold mix, and tars
 - Glues, adhesives, and solvents
 - Herbicides, pesticides, and fertilizers
 - Paints, stains, and curing compounds
 - Other hazardous or toxic substances
- How** Hazardous materials and wastes shall be managed in accordance with the following procedures:
- Minimize the amount of hazardous materials stored at the construction site and the production and generation of hazardous waste at the construction site.
 - Cover or containerize and protect from vandalism any hazardous materials and wastes.
 - Clearly mark all hazardous materials and wastes. Place hazardous waste containers in secondary containment systems if stored at the construction site.
 - Stockpiled cold mix should be placed on and covered with plastic.
 - Do not mix waste materials, because this complicates or inhibits disposal and recycling options and can result in dangerous chemical reactions.
 - Storm water that collects within secondary containment structures must be inspected prior to being discharged to ensure no pollutants are present. Contaminated storm water must be managed per Utility Environmental Practices (EPs)
 - Spills cannot be discharged from a secondary containment system. See BMP on Spill Control.
 - Hazardous waste must be segregated from other solid waste and disposed of properly.
 - In addition to following this BMP, employees or contractors are responsible for compliance with federal, state, and local laws regarding storage, handling, transportation, and disposal of hazardous waste.
- Maintenance and Inspection**
- Routinely inspect the covers on hazardous material storage areas for tears or flaws and repair as necessary.
 - All secondary containment systems must be able to hold the volume of the largest container in the storage area, plus provide sufficient additional capacity for storm events.
 - Perform routine inspections to ensure that no hazardous materials or waste are improperly left exposed to storm water.

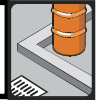

When This contaminated soil management BMP should be used whenever soil contamination is suspect or contaminated soil is encountered. Construction crews should be extra vigilant on projects located in highly urbanized or industrial areas where soil contamination may have occurred because of spills, illicit discharges, and leaks from underground storage tanks.

Contaminated soils may also be encountered during digging and trenching activities on highways and roadways.

How Contaminated soil wastes should be managed in accordance with the following procedures:

- Identify contaminated soil; look for the following:
 - Soil that is discolored, black, gray, white; or
 - Soil that has an unusual odor, such as, petroleum, acid, alkaline, sewage, solvent, or any other chemical smell.
- If any potentially contaminated soil is detected, discontinue the activity and contact the projects Environmental Representative.
- Contaminated soils must be managed properly per Utility Environmental Practices (EPs).

Maintenance and Inspection

- Perform routine inspections of digging and trenching operations looking for contaminated soils.
- All contaminated soils must be managed as hazardous substances, if applicable, in accordance with applicable federal, state, and local laws.



When Use this BMP on all construction sites that use temporary or portable sanitary/septic waste systems.

How Sanitary/septic wastes shall be managed in accordance with the following procedures:

- Incorporate into regular safety meetings, education of employees, contractors, and suppliers on:
 - potential dangers to humans and the environment from sanitary/septic wastes
 - approved sanitary/septic waste storage and disposal procedures.
- Temporary sanitary facilities should be located away from drainage facilities, watercourses, and from traffic circulation. When subjected to high winds or risk of high winds, temporary sanitary facilities shall be secured to prevent overturning.
- Sanitary wastewater should not be buried or discharged, except to a properly permitted sanitary sewer discharge facility. A permit may be required from the local Sanitation District.
- Use only reputable, licensed sanitary/septic waste haulers.
- Temporary sanitary facility's holding tanks shall be emptied prior to transport.

Maintenance and Inspection

- Onsite sanitary/septic waste storage and disposal should be routinely inspected.
- Ensure that sanitary/septic facilities are maintained in good working order routinely serviced by a licensed service.

Pictures

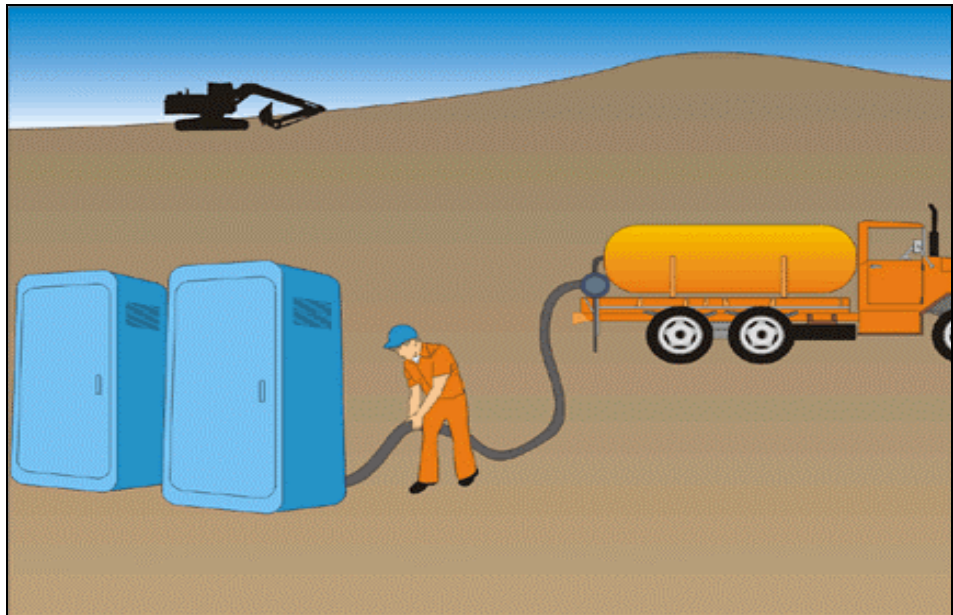

Good septic waste management.

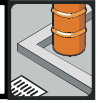

- When**
- Liquid waste management is applicable to construction projects that generate any of the following non-hazardous byproducts, residuals, or wastes, such as:
 - Drilling slurries and drilling fluids
 - Grease-free and oil-free wastewater and rinse water
 - Dredging spoils
 - Other non-storm water liquid discharges not permitted by separate permits.
 - Separate BMPs should also be referenced for the following onsite liquid wastes:
 - Dewatering operations
 - Liquid hazardous wastes, or
 - Concrete slurry residue

- How**
- Vehicle and equipment cleaning using water is discouraged on site.
 - Drilling residue and drilling fluids should be disposed of in accordance with Sempra Energy Utilities procedures at an approved disposal site. Coordinate the disposal of these wastes with your Environmental Representative.
 - Wastes generated as part of an operational procedure, such as waterladen dredged material and drilling mud, should be contained and not allowed to flow into drainage channels or receiving waters.
 - Contain non-hazardous liquid wastes in a controlled area, such as a lined holding pit, lined sediment basin, roll-off bin, or portable tank.
 - Containment devices must be of sufficient quantity or volume to completely contain the liquid wastes generated and any addition volume based on anticipated rainfall.
 - **Do not locate containment areas or devices where accidental release of the contained liquid can threaten health or safety, or discharge to watercourses, storm drain system, or to a receiving water.**
 - Capture all liquid wastes running off a surface that has the potential to affect the storm drainage system. Examples are: wash water and rinse water from cleaning walls or pavement.
 - If the liquid waste is sediment laden, use a sediment trap or capture in a containment device and allow sediment to settle.
 - Disposal of liquid wastes are subject to specific laws and regulations, or to requirements of other permits secured for the construction project. Contact your Environmental Representative for further information.

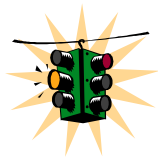

Maintenance and Inspection

- Remove deposited solids from containment areas and containment systems as needed, and at the completion of the project.
- Inspect containment areas and containment systems routinely for damage, and repair as needed.

BMP DETAILS



Section 3 – Non-Storm Water Discharge Controls

Non-Storm Water Discharge Controls include general site and operations BMP measures that minimize pollution of water. Non-Storm Water Discharge Controls presented in this Manual include the following:

- BMP 3-01 Dewatering Operations
- BMP 3-02 Paving Operations
- BMP 3-03 Vehicle and Equipment Washing
- BMP 3-04 Vehicle and Equipment Fueling
- BMP 3-05 Concrete/Coring/Sawcutting and Drilling Waste Management
- BMP 3-06 Dewatering Utility Substructures and Vaults
- BMP 3-07 Vegetation Management including Mechanical and Chemical Weed Control
- BMP 3-08 Over-Water Protection
- BMP 3-09 Removal of Underground Utility Location/Mark-Out Paint

BMP DETAILS

This page intentionally left blank.

NON-STORM WATER DISCHARGE CONTROLS

Dewatering Operations

BMP 3-01



When

- This BMP is applicable to trench or excavation dewatering.
- Discharges of non-storm water from a trench or excavation that contain sediments or other pollutants to the sanitary sewer, storm drain systems, creek bed (even if dry), or receiving waters is prohibited. Water from dewatering activities is generally allowed to be discharged if the water does not contain any sediment or other pollutants. Verify with your local jurisdiction.
- Generally, non-contaminated discharges of non-storm water to lands (such as infiltration) are allowed. Some areas may require a permit or other regulatory approval. Verify with your local jurisdiction.
- **This BMP is not applicable to utility vault or sub-structure dewatering. For these applications, refer to the BMP on Dewatering Utility Substructures and Vaults.**
- **This BMP is not applicable if the water is known, or suspected to be, contaminated. Under these conditions, contact your Environmental Representative.**

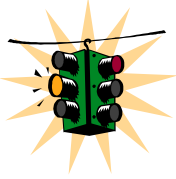

How

Water generated by dewatering activities may be managed in accordance with the following procedures:

- Use water where possible for construction activities such as compaction and dust control. If used for these applications, ensure that the water will infiltrate and not run-off from the land to storm drain systems, to creek beds (even if dry) or to receiving waters.
- If allowed, infiltrate to an appropriate landscaped, vegetated or soil area. Note: Infiltration may be prohibited in accordance with local requirements. See “When” above.
- If water is to be discharged to land for infiltration:
 - The water may contain sediments, but must not be contaminated with other pollutants.
 - The water must not run-off from the land to storm drain systems, to creek beds (even if dry) or other surface waters.
 - Permission may be needed from the property owner on which the infiltration will occur.
- Water from dewatering, that contains only sediment, may be discharged if the sediment is allowed to settle out or the sediment is filtered out first. Alternatively, a vacuum truck may be used to remove the water and haul it to an authorized discharge location.
- If a permit is required, provide temporary onsite storage (Baker tanks, etc.) of water removed from trenches, excavations, etc., until a permit to discharge is obtained.
- If a permit is obtained for discharge to a storm water or sanitary sewer system, conduct all dewatering discharge activities in accordance with permit requirements.

Maintenance and Inspection

- Inspect pumps, hoses and all equipment before use. Monitor dewatering operations to ensure it does not cause offsite discharge or erosion.
- Inspect routinely, when applicable activities are under way.



When Use this BMP for projects that involve pavement surfacing, resurfacing, removal, or patching applications of the following:

- Cold mix
- Asphalt
- Chip seal, seal coat, tack coat, slurry seal, or fog seal
- Portland cement concrete

For pavement grinding, sawcutting, coring or drilling, refer to BMP Concrete/Coring/Sawcutting and Drilling Waste Management.

How Use the following methods as applicable:

- Protect storm drain inlets near work and downgradient of the area to be paved.
- If onsite mixing is planned then an area must be designed for conducting the mixing. This area should be paved or made impervious (e.g., plastic or wood sheeting) and be located away from storm drain inlets or watercourses.
- Minimize overspray of tackifying emulsions or placement of other paving materials beyond the limits of the area to be paved.
- Use dry methods to clean equipment and conduct cleaning in accordance with the BMP on Vehicle and Equipment Washing.
- Material use and stockpiles to be managed in accordance with BMPs on material Use and Stockpile Management.
- Collect and remove all broken asphalt and concrete, recycle when feasible and dispose of materials in accordance with local, state, and federal requirements.
- **Do not apply asphalt, concrete paving, seal coat, tack coat, slurry seal or fog seal if rain is expected during the application or curing period.**
- **Avoid if possible, transferring, loading, or unloading paving materials near storm drain inlets or watercourses. If not possible, use BMP on Storm Drain Inlet Protection.**

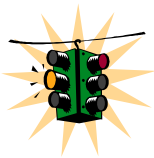

Maintenance and Inspection

- Inspect and maintain equipment and machinery routinely to minimize leaks and drips.
- Inspect inlet protection measures routinely.

NON-STORM WATER DISCHARGE CONTROLS

Vehicle and Equipment Washing

BMP 3-03



When Use these procedures on all construction sites where vehicle and equipment cleaning is performed. Note that onsite vehicle and equipment washing is not typically performed on utility type construction projects and requires specific approval of a Utility Environmental Representative.

How Use the following methods as applicable:

- Use “dry” cleaning methods such as wiping down, rather than water washing vehicles or equipment.
- Whenever possible washing should not be conducted at the construction site
- If onsite vehicle washing is authorized by the Environmental Representative, use the following general methods:
 - Vehicle and equipment washing must be located away from storm drain inlets, drainage systems, or watercourses.
 - Place sand bags or another type of berm around storm drain inlets and drainage systems to prevent wash water from entering a storm inlet, drainage system or watercourse.
 - Never discharge wash water to the storm drain system.
 - Use as little water as possible. High-pressure sprayers may use less water than a hose.
 - Use a positive shutoff valve to minimize water usage.

Maintenance and Inspection

Monitor employees and contractors through the duration of the construction project to ensure appropriate practices are being implemented.

NON-STORM WATER DISCHARGE CONTROLS

Vehicle and Equipment Fueling

BMP 3-04



When Use this BMP for projects where onsite fueling of vehicles and equipment, including handheld equipment, is planned.

Vehicle and equipment fueling, except for handheld equipment, is typically not done on the construction site. Onsite fueling of vehicles and equipment may be planned if it is impractical to send vehicles and equipment off site for fueling.

Handheld equipment is treated separately from other equipment. Handheld equipment includes those smaller, manually operated pieces of equipment such as trenchers, mowers, chainsaws, generators, and other equipment that need fueling during regular daily operation.

How Use the following measures as applicable:

Fueling Vehicles and Handheld Equipment

- If practical, fuel vehicles and equipment off site.
- Mobile fueling equipment is the preferred equipment used for onsite fueling.
- Fuel storage and fueling areas should be located away from storm drain inlets, drainage systems, and watercourses.
- All fueling will be conducted with the fueling operator in attendance at all times regardless if fuel nozzles are equipped with automatic shutoff features.
- Fuel tanks should not be “topped off.”
- All fueling operators should have readily available spill containment and cleanup equipment and materials.
- Clean up any spills immediately and properly dispose of contaminated materials.
- Properly store and dispose of rags and absorbent material used to clean up any spilled fuel.
- Mobile fueling trucks and operators must have all necessary permits, licenses and training.

Maintenance and Inspection

- Check to ensure adequate supply of spill cleanup materials are available.
- Perform routine inspections of designated fueling areas.
- Report all spills immediately to the project Supervisor or the Environmental Representative

NON-STORM WATER DISCHARGE CONTROLS

Concrete/Coring/Sawcutting and Drilling Waste Management

BMP 3-05



When Projects where concrete and asphalt are used or where slurry or pavement/concrete wastes are generated by construction activities, including:

- Sawcutting
- Coring/drilling
- Grinding, re-paving or patching
- Encasing conduit in concrete
- Tower footings

For managing any concrete curing compounds, use the BMP on Hazardous Materials/Hazardous Waste Management. For managing paving operations, use BMP Paving Operations.

How

- Install storm drain protection at any down-gradient inlets that may be impacted by the activity. See the BMP on Storm Drain Inlet Protection.

- Minimize the amount of water used during coring/drilling or sawcutting. During wet coring or sawcutting, use shovel or wet vacuum to lift the slurry from the pavement. Additionally, if wet vacuuming is not adequate to capture wastewater from the activity, sand bag barriers or other containment should be used.

- If concrete residue remains after drying, the area should be swept up and residue removed to avoid contact with storm water or entering a storm drain or waterbody via the wind.

- **Do not wash residue or particulate matter into a storm drain inlet or watercourse.**

- The following options should be used for concrete truck chute and/or pump and hose washout:

- If available, arrange to use an existing concrete washout station. Upon entering site, concrete truck drivers should be instructed about practices being used on site.
- **Concrete Washouts:** Washout stations can be a plastic lined temporary pit or bermed areas designed with sufficient volume to completely contain all liquid and waste concrete materials plus enough capacity for rainwater. The designated area must be located away from storm drain inlets, or watercourses.
- **Washout in Trench:** Manually rinsing the concrete truck chute into the trench itself.
- **Bucket Washout:** Manually rinsing the chute into a wheelbarrow, plastic bucket or pail, and then empty the bucket into the concrete truck barrel or on top of the placed concrete.

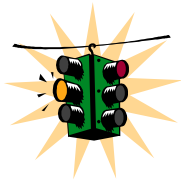

Maintenance and Inspection

- Responsible personnel should ensure that all concrete truck drivers are instructed about project practices when the trucks arrive onsite.
- Clean out designated washout areas as needed or at a minimum when the washout is 75 percent full to maintain sufficient capacity throughout the project duration.
- Any designated onsite washout areas must be cleaned out and all debris removed upon project completion. Dispose of concrete waste according to the BMP on Solid Waste Management.
- Inspect routinely, when applicable activities are underway to ensure that concrete washout does not overflow.

NON-STORM WATER DISCHARGE CONTROLS

Dewatering Utility Substructures and Vaults

BMP 3-06



When This BMP is applicable to utility substructure (vault) dewatering. This BMP does not apply to trench, excavation or other general dewatering associated with construction activities.

How The discharge of water from dewatering of vaults and substructures to the storm drain is allowed under an existing NPDES permit (General Permit CAG990002, Order No. 2001-11-DWQ). General requirements for discharge under this permit are listed below:

- All dewatering discharges conducted by utility crews, including contractors, shall follow the latest versions of SCG/SDG&E Environmental Practice (EP) on Vault and Substructure Dewatering.
- Discharges to land require prior approval from the landowner.
- If the water to be discharged conforms to the practices within the EP, the discharge is allowed.
- **During discharge, do not allow pollutants (e.g., sediment) to come in contact with the discharge. For example, if there is pre-existing soil in the path of the discharge (i.e., gutter), it must be swept up or avoided before discharging the substructure water.**

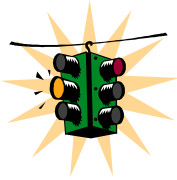

Maintenance and Inspection

- Implement applicable provisions of the Environmental Practice.
- Inspect pumps, hoses and equipment before use and routinely when applicable activities are underway.
- Observe dewatering activities to ensure they do not cause erosion or discharge of potential pollutants.

NON-STORM WATER DISCHARGE CONTROLS

Vegetation Management Including Mechanical and Chemical Weed Control

BMP 3-07

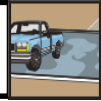

When Use this BMP whenever vegetation control is used. Vegetation control may consist of manual or mechanical removal of vegetation and/or chemical treatment.

How General Vegetation Management Procedures:

- Do not allow vegetation debris to enter storm drain inlets and watercourses.
- Identify drain inlets and watercourses, both upstream and downstream of the work site(s).
- Pre-plan the work to protect stormwater drainage systems and watercourses from discharge of potential pollutants, maintain equipment in good operating condition.
- Set up the work area to minimize the tracking of material by vehicles and equipment in or out of the work area.

Practice Good Housekeeping at the Work Site(s):

- Litter and debris should be collected and disposed of properly.
- Containers of liquids should be secured with lids until needed.
- Transport collected non-hazardous materials for proper disposal. If the material is a hazardous waste, follow the BMP on Hazardous Materials & Hazardous Waste Management. Contact your Environmental Representative.
- If a leak or spill occurs, protect drainage systems and watercourses from spilled material; follow the BMP on Storm Drain Inlet Protection.

Mechanical Weed Control Procedures

Mechanical weed control is the physical removal of weeds or unwanted vegetation growing around electric utility poles and electric distribution or transmission structures for fire control.

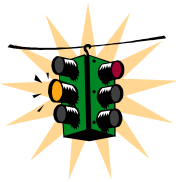

- **Do not stack or leave removed weeds or vegetation or other debris on or near drain inlets or in the storm water drainage system or watercourses.**
- **Do not fuel equipment next to drain inlets or place fuel or oil cans near or in watercourses, the storm drainage system or next to a drain inlet.**
- **Because of fire control requirements, do not leave cut vegetation around structures.**

Chemical Weed Control Procedures

This method of weed and vegetation control uses herbicides to eliminate and prevent weed growth. The purpose is to control vegetation growth year-round as needed for effective fire control.

To achieve effective vegetation control through chemical means and protect the environment, application personnel should:

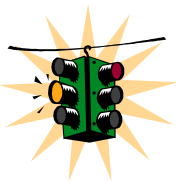

- Use the correct herbicide for the application.
- Consider the seasonal timing of the application as applicable.
- **Do not use chemical vegetation control prior to a forecasted rain event.**

The applicators shall follow the following procedures:

- Only use those herbicides approved by SDG&E/SCG.
- Application of herbicides must conform to the SDG&E/SCG herbicide application protocol in addition to any Contractor owned protocols and label instructions. Contact your Environmental Representative for additional information.

NON-STORM WATER DISCHARGE CONTROLS

Vegetation Management Including Mechanical and Chemical Weed Control



How (continued)

- Apply pesticides only as specified on the “Pesticide Use Recommendation” on the label. The pesticide label is considered the law, and use of an herbicide inconsistent with the label is considered a violation. Follow safety and application methods as specified in the Annual Pesticide Safety Training.
- Follow the herbicide/pesticide application protocol when near storm water drainage system or watercourses.
- Calibrate the spray rig as needed, to ensure accurate application of herbicides.
- Record the use of all herbicides.
- Avoid using overhead irrigation for as long as recommended by the chemical manufacturer after applying pesticides or post-emergents.
- Avoid applying post-emergents prior to a predicted rain event.

Maintenance and Inspection

- Ensure that spraying equipment is maintained to prevent malfunctions.
- Inspect to confirm that mechanical and chemical weed control procedures have not created an erosion problem.

NON-STORM WATER DISCHARGE CONTROLS

Over-Water Protection

BMP 3-08



- When** Prior to conducting over water activities, confirm the need for permits with appropriate local and state agencies.
- This BMP applies to projects where:
- Construction, maintenance or repair activities will be conducted above surface waters. These activities include, but are not limited to, chipping, grinding, scraping, welding/burning, painting, wrapping and coating of pipes and conduits.
 - Surface waters (dry or running) include creeks, streams, rivers, lakes and wetlands, bays, estuaries and oceans.
- How** Use the following measures as applicable:
- Containment systems must be properly designed and installed prior to the beginning of any operation that may impact a water body to prevent discharge of pollutants to surface waters.
 - The work area should be kept clean of all trash and potential pollutants.
 - Containment booms should be placed around the area of work as necessary to contain the discharge of potential contaminants such as oil and hydraulic fluid.
 - Special attention should be given to existing and forecasted wind and weather conditions to prevent pollutant discharges to surface waters.
 - Shrouds should be used to prevent paint overspray, welding slag, and other pollutants from entering surface waters and being dispersed into the air. Shrouding may not be effective during periods of high wind.
 - Shrouds should be large enough to adequately enclose or segregate the working area from surface waters. This may include a plywood barrier, visqueen, and scaffolding to help prevent fugitive material from entering surface waters.
 - Support structures such as scaffolding shall be used in conjunction with shrouding to withstand potential wind stress.
 - Contaminated shrouding material and equipment shall be thoroughly cleaned or disposed of properly.
- Maintenance and Inspection**
- Inspect the containment systems and shrouds routinely during work activities to ensure their integrity.

NON-STORM WATER DISCHARGE CONTROLS

Removal of Underground Utility Location/Mark-Out Paint

BMP 3-09



When Use this BMP when utility projects involve mark-out by painting surfaces where underground utilities are located and where paint is required to be removed by local jurisdictions or another authority.

How Use the following methods and options to remove Utility Mark-Out Paint:

- Use non-toxic, light degradable mark-out paint when possible
- Hydro Pressure wash
- Dry abrasive blast/grinding
- Wet abrasive blast/grinding
- Wet/Dry Vacuum
- Dry Sweep
- Install storm drain inlet protection at adjacent down gradient inlets during wet hydro pressure washing and wet abrasive blasting and grinding.
- Minimize the amount of water used during hydro washing.
- Use shovel or wet vacuum to lift the paint slurry from the pavement or surface.
- If wet vacuuming is not adequate to capture all wastewater from these activities, use additional containment (sand bags, booms, or other containment devices) methods near the work area to prevent the discharge to a storm drain inlet or watercourse.
- If paint residue remains after drying, the area should be swept up and residue removed to avoid contact with storm water.
- If paint residue remains after sweeping, the area can be water washed, as long as the water containing the paint residue is not allowed to enter storm drain inlets or watercourses.
- All waste should be disposed of using the BMPs for Liquid Waste Disposal.

Maintenance and Inspection

- Inspect all containment systems to ensure proper placement prior to starting utility paint removal operations
- Inspect and adjust equipment frequently; and maximize efficiency of the paint removal operations.

BMP DETAILS



Section 4 – Erosion Control and Soil Stabilization

Erosion is the detachment of soil by water or wind. Erosion is a natural process that can be accelerated by construction activities such as grading and trenching. For example, when a site is cleared and grubbed, protective vegetation is removed and the disturbed soil is directly exposed to wind and water. Erosion Controls protect the soil surface and prevent the soil particles from being detached by rainfall or wind. Preservation of Existing Vegetation is an example of an Erosion Control BMP.

Soil Stabilization is a form of erosion control. It protects the exposed soil surface from rain and wind thereby preventing erosion. Hydroseeding is an example of a Soil Stabilization BMP. Erosion Control and Soil Stabilization BMPs in this Manual include:

- BMP 4-01 Preservation of Existing Vegetation
- BMP 4-02 Temporary Soil Stabilization (General)
- BMP 4-03 Hydraulic Mulch
- BMP 4-04 Hydroseeding
- BMP 4-05 Soil Binders
- BMP 4-06 Straw Mulch
- BMP 4-07 Geotextiles, Plastic Covers and Erosion Control Blankets/Mats
- BMP 4-08 Dust (Wind Erosion) Control

BMP DETAILS

This page intentionally left blank.

EROSION CONTROL AND SOIL STABILIZATION

Preservation of Existing Vegetation

BMP 4-01



When This BMP is applicable to projects when:

- There are areas on site where no construction activity is planned or will occur later.
- Identify areas to be preserved in the immediate vicinity of the construction site, and mark as appropriate before clearing and grubbing or other soil disturbance activities begin.
- Areas with vegetation that can be preserved to protect against soil erosion, such as on steep slopes, watercourses, and building sites in wooded areas.
- Areas designated as Environmentally Sensitive Areas (ESAs), or where federal, state, or local government regulations require preservation, such as wetlands, vernal pools, marshes, etc. These areas are typically flagged by a qualified biologist.

How Use the following measures as applicable:

- Preserve existing vegetation whenever possible.
- If necessary, contact the project Environmental Representative for any clarification regarding areas to be preserved.
- Whenever possible minimize disturbed areas by locating temporary roadways to avoid stands of trees and shrubs and follow existing contours to reduce cutting and filling.
- Construction materials, equipment storage and parking areas should be located outside the drip line of any tree to be retained.
- Consider the impact of grade changes to existing vegetation and the root zone.
- Remove any markings, barriers, or fencing after project is completed.

Maintenance and Inspection

- Maintain the clearly marked limits of disturbance during construction as appropriate to preserve vegetation.
- Inspect barriers regularly during construction.

Pictures

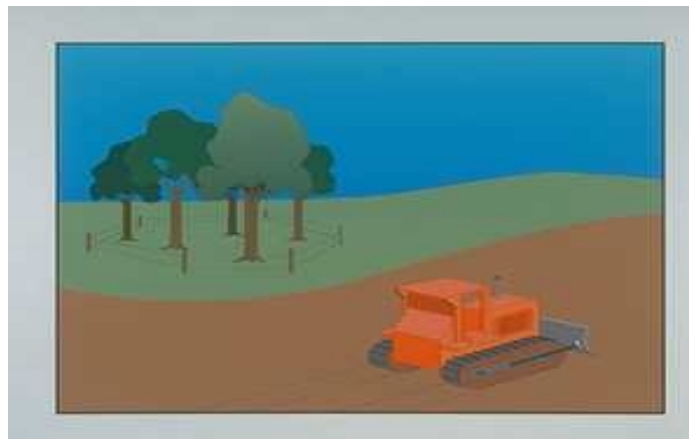

Vegetation to be preserved is marked and outside the work area.

EROSION CONTROL AND SOIL STABILIZATION

Temporary Soil Stabilization (General)

BMP 4-02



- When** This BMP is applicable to major projects when steep slopes are disturbed.
- For surface protection methods to prepare or protect the soil surface from the combined erosive effects of wind, rain, and storm water runoff.
 - On slopes where the soil has been exposed because of construction activities, one or more Soil Stabilization BMPs may be required to be implemented.
- How**
- Use one or more of the below temporary soil stabilization practices when applicable as described above:
 - Hydraulic Mulch.
 - Hydro seeding.
 - Soil Binders.
 - Straw Mulch.
 - Geotextiles, Plastic Covers and Erosion Control Blankets/Mats.
 - Implement prior to the onset of precipitation.
 - Implement BMPs such as fiber rolls or gravel bag berms to break up the slope lengths as follows:
 - On steep slopes, BMPs should be placed on slopes 100 feet and greater at intervals no greater than 50 feet.
 - On very steep slopes, BMPs should be placed on slopes 50 feet and greater at intervals no greater than 25 feet.
 - Permanent erosion control shall be applied to areas deemed substantially complete during the project's defined seeding window.
 - Refer to individual Soil Stabilization BMPs for specific instructions for use.
- Maintenance and Inspection**
- Refer to individual temporary soil stabilization BMPs for maintenance and inspection requirements.

Pictures



Applying a tackifier using a trailer mounted pump and hose.



Applying soil stabilization manually in harder to reach areas.



- When**
- Hydraulic mulch is typically applied to disturbed areas requiring temporary protection until permanent vegetation is established or disturbed areas that must be re-disturbed following an extended period of inactivity.
 - Avoid use in areas where the mulch would be incompatible with immediate earthwork activities and would have to be removed.
- How**
- Prior to application, roughen embankment and fill areas by rolling with a crimping or punching type roller or by track walking. Track walking shall only be used where other methods are impractical.
 - Avoid mulch over-spray onto the traveled way, sidewalks, lined drainage channels, and existing vegetation.
 - Hydraulic Mulches:
 - Apply as a liquid slurry using a hydraulic application machine (i.e., hydroseeder) at rates of mulch and stabilizing emulsion recommended by the manufacturer. Wood fiber hydraulic mulches are generally short-lived (only last a part of a growing season) and must be applied 24 hrs before rainfall to dry and become effective.
 - Hydraulic Matrices:
 - Apply a combination of wood fiber and/or paper fiber mixed with acrylic polymers as binders. Apply as a liquid slurry using a hydraulic application machine (i.e., hydroseeder) at rates recommended by the manufacturer. Hydraulic matrices must be applied 24 hours before rainfall to dry and become effective.
 - Bonded Fiber Matrix (BFM)
 - Apply BFM using a hydraulic application machine (mulch and tackifier are pre-mixed in a single bag) in accordance with manufacturers instructions. Do not apply immediately before, during, or after a rainfall.
- Maintenance and Inspection**
- Maintain an unbroken, temporary mulched ground cover throughout the period of construction when the soils are not being reworked. Inspect before expected rainstorms and repair any damaged ground cover and re-mulch exposed areas of bare soil.
 - After any rainfall event, maintain all slopes to prevent erosion.

Pictures



Applying hydraulic mulch.



Close-up of bonded fiber matrix



- When** Hydroseeding typically consists of applying a mixture of fiber, seed, fertilizer, and stabilizing emulsion with hydro-mulch equipment, which temporarily protects disturbed soil areas from erosion. It is applied on:
- Disturbed Soil Areas (DSAs) requiring temporary protection until permanent vegetation is established, or
 - DSAs that must be redisturbed following an extended period of inactivity.
- How**
- Avoid use of hydroseeding in areas where the best management practice (BMP) would be incompatible with future earthwork activities and would have to be removed such as:
 - Steep slopes are difficult to protect with temporary seeding.
 - Temporary seeding may not be appropriate in dry periods without supplemental irrigation.
 - Temporary vegetation may have to be removed before permanent vegetation is applied.
 - Temporary vegetation is not appropriate for short-term inactivity.
 - Hydroseeding can be accomplished using a multiple-step (with straw mulch) or a one-step process (mixed with hydraulic mulch, hydraulic matrix, or bonded fiber matrix). When the one-step process is used to apply the mixture of fiber, seed, etc., the seed rate shall be increased to compensate for all seed not having direct contact with the soil.
 - Prior to application, roughen the slope, fill area, or area to be seeded with the furrows trending along the contours.
 - Apply a straw mulch as necessary to keep seeds in place and to moderate soil moisture and temperature until the seeds germinate and grow.
 - Follow-up applications shall be made as needed to cover weak spots, and to maintain adequate soil protection.
 - Avoid over-spray onto the travel way, sidewalks, drainage channels and existing vegetation.
- Maintenance and Inspection**
- All seeded areas shall be inspected for failures and re-seeded, fertilized, and mulched within the planting season, using not less than half the original application rates. Any temporary revegetation efforts that do not provide adequate cover must be revegetated.
 - After any rainfall event, maintain all slopes to prevent erosion.

Pictures



Applying hydroseed.



When Soil binders are typically applied to disturbed soil areas requiring short-term temporary protection. Because soil binders can often be incorporated into the work, they may be a good choice for areas where grading activities will soon resume.

- How**
- Selection of soil binders should be approved by the projects Environmental Representative after an evaluation of site-specific factors. Binders have the following limitations:
 - Soil binders generally experience spot failures during heavy rainfall and may need reapplication after a storm and do not hold up to pedestrian or vehicular traffic.
 - Soil binders may not penetrate soil surfaces made up primarily of silt and clay, particularly when compacted.
 - Some soil binders may not perform well with low relative humidity. Under rainy conditions, some agents may become slippery or leach out of the soil.
 - May not cure if low temperatures occur within 24 hours of application.
 - Follow manufacturer’s recommendations for application procedures and cleaning of equipment after use. Any onsite cleaning must use appropriate BMPs for pollution prevention plans.
 - Prior to application, roughen embankment and fill areas. Track walking shall only be used where rolling is impractical.
 - Soil binders should not be applied during or immediately before rainfall, as they require a minimum curing time of 24 hours before they are fully effective.
 - Avoid over-spray onto the traveled way, sidewalks, lined drainage channels, sound walls, and existing vegetation.
 - **Do not apply soil binders to frozen soil, areas with standing water, under freezing conditions, or when the temperature is below 4°C (40°F) during the curing period.**
 - More than one treatment is often necessary, although the second treatment may be diluted or have a lower application rate.
 - For liquid agents:
 - Crown or slope ground to avoid ponding.
 - Uniformly pre-wet ground according to manufacturer’s recommendations.
 - Apply solution under pressure. Overlap solution 150 to 300 mm (6 to 12 in).
 - Allow treated area to cure for the time recommended by the manufacturer; typically, at least 24 hours.
 - Apply second treatment before first treatment becomes ineffective, using 50 percent application rate.
 - In low humidities, reactivate chemicals by re-wetting according to manufacturer’s recommendations.

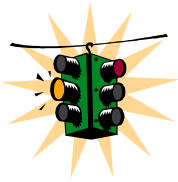

Maintenance and Inspection

- Reapplying the selected soil binder may be needed for proper maintenance. Traffic areas should be inspected routinely.
- After any rainfall event, maintain all slopes to prevent erosion.



- When** Straw mulch is used when:
- Temporary soil stabilization surface cover is needed on disturbed areas until soils can be prepared for re-vegetation and permanent vegetation is established.
 - In combination with temporary and/or permanent seeding strategies to enhance plant establishment.
 - Note, there is a potential for introduction of weed-seed and unwanted plant material with straw.
- How**
- A tackifier is the preferred method for anchoring straw mulch to the soil on slopes. Tackifiers act to glue the straw fibers together and to the soil surface, and the tackifier shall be selected based on longevity and ability to hold the fibers in place. Soil binders (tackifier) will generally experience spot failures during heavy rainfall events.
 - A tackifier is typically applied at a rate of 125 pounds per acre. In windy conditions, the rates are typically 150 pounds per acre.
 - Crimping, punch roller-type rollers, or track-walking may also be used to incorporate straw mulch into the soil on slopes. Track walking shall only be used where other methods are impractical.
 - Avoid placing straw onto the traveled way, sidewalks, lined drainage channels, sound walls, and existing vegetation.
 - Straw mulch with tackifier shall not be applied during or immediately before rainfall.
 - Apply loose straw at a minimum rate of 4,000 pounds per acre, either by machine using a straw blower or by hand distribution.
 - The straw mulch must be evenly distributed on the soil surface.
 - Anchor the mulch in place by using a tackifier or by “punching” it into the soil mechanically. “Punching” of straw does not work in sandy soils.
 - Methods for holding the straw mulch in place depend on the slope steepness, accessibility, soil conditions and longevity. If the selected method is incorporation of straw mulch into the soil, then do as follows:
 - On small areas, a spade or shovel can be used.
 - On slopes with soils, which are stable enough, and of sufficient gradient to safely support construction equipment without contributing to compaction and instability problems, straw can be “punched” into the ground using a knife-blade roller or a straight bladed coulter, known commercially as a “crimper.”
 - On small areas and/or steep slopes, straw can also be held in place using plastic netting or jute. The netting shall be held in place using 11 gauge wire staples, geotextile pins or wooden stakes (as described in BMP on “Geotextiles, Plastic Covers and Erosion Control Blankets/Mats”).
 - Remove straw as necessary prior to permanent seeding or soil stabilization.
- Maintenance and Inspection**
- The key consideration in maintenance and inspection is that the straw needs to last long enough to achieve erosion control objectives.
 - Reapplication of straw mulch and tackifier may be required to maintain effective soil stabilization over disturbed areas and slopes.
 - After any rainfall event, maintain all slopes to prevent erosion.

Pictures



Straw mulch.



- When**
- The following methods are used when disturbed soils may be particularly difficult to stabilize or access, including the following situations:
 - Steep slopes, generally steeper than 1:3 (V:H).
 - Slopes where the erosion hazard is high.
 - Slopes and disturbed soils where mulch must be anchored.
 - Disturbed areas where plants are slow to develop adequate protective cover.
 - Channels with high flows.
 - Channels intended to be vegetated.
 - Slopes adjacent to water bodies of Environmentally Sensitive Areas (ESAs).
 - Blankets and mats are generally not suitable for excessively rocky sites, or areas where the final vegetation will be mowed (because staples and netting can catch in mowers).
 - Plastic results in 100 percent runoff, therefore, their use is limited to:
 - Covering stockpiles.
 - Covering small graded areas for short periods, such as through an imminent storm event, until alternative measures may be installed.
- How**
- Proper site preparation is essential to ensure complete contact of the blanket or matting with the soil.
 - Grade and shape the area of installation.
 - Remove all rocks, clods, vegetation or other obstructions so that the installed blankets or mats will have complete, direct contact with the soil.
 - Prepare seedbed by loosening of topsoil.
 - Seed the area before blanket installation for erosion control and revegetation. Seeding after mat installation is often specified for turf reinforcement application. When seeding prior to blanket installation, all check slots and other areas disturbed during installation must be re-seeded. Where soil filling is specified, seed the matting and the entire disturbed area after installation and prior to filling the mat with soil.
 - U-shaped wire staples, metal geotextile stake pins or triangular wooden stakes can be used to anchor mats and blankets to the ground surface.
 - Wire staples and metal stakes should be driven flush to the soil surface.
 - All anchors should be 6 in to 18 in long and have sufficient ground penetration to resist pullout. Longer anchors may be required for loose soils.
 - Installation on slopes – Consult the manufacturer’s recommendations for installation. In general, these will be as follows:
 - Begin at the top of the slope and anchor the blanket in a 6 in deep by 6 in wide trench. Backfill trench and tamp earth firmly.
 - Unroll blanket downslope in the direction of water flow.
 - Overlap the edges of adjacent parallel rolls 2 in to 3 in and staple every 3 ft.
 - When blankets must be spliced, place blankets end over end (shingle style) with 6 in overlap. Staple through overlapped area, approximately 12 in apart.
 - Lay blankets loosely and maintain direct contact with the soil. Do not stretch.
 - Staple blankets sufficiently to anchor blanket and maintain contact with the soil. Staples shall be placed down the center and staggered with the staples placed along the edges.
 - Blankets and mats must be removed and disposed of prior to application of permanent soil stabilization measures.



Maintenance and Inspection

- Areas treated with temporary soil stabilization should be inspected routinely and before and after significant forecasted storm events. Any failures should be repaired immediately. Areas treated with temporary soil stabilization should be maintained to provide adequate erosion control. Temporary soil stabilization should be reapplied or replaced on exposed soils when greater than 10 percent of the previously treated area becomes exposed or exhibits visible erosion.
- If washout or breakage occurs, re-install the material after repairing the damage to the slope or channel.

Pictures



Several types of Erosion Control Blankets.

EROSION CONTROL AND SOIL STABILIZATION

Dust (Wind Erosion) Control

BMP 4-08



When This practice is implemented on exposed soils or materials subject to wind erosion.

How Use the following measures as applicable:

- Water applied for dust control should be applied evenly and in a manner that does not generate runoff.
- Appropriate methods of applying dust control (covers or water and the means to apply it) should be available for projects with the potential to create dust.
- Dust control must be implemented in accordance with local air quality requirements.
- Dust control methods should be approved by an Environmental Representative.
- Obtain prior approval to use any chemical dust suppressant from the projects Environmental Representative.
- Non-potable water should not be conveyed in tanks or drainpipes that will be used to convey potable water and there should be no connection between potable and nonpotable supplies. Non-potable tanks, pipes and other conveyances should be marked “NON-POTABLE WATER – DO NOT DRINK.”
- If reclaimed wastewater is used for dust control, the sources and discharge must meet California Department of Health Services water reclamation criteria and the Regional Water Quality Control Board (RWQCB) requirements. Approval for use of reclaimed wastewater must be obtained from the projects Environmental Representative.

(dry or running)

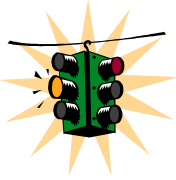

Maintenance and Inspection

- Check areas protected to ensure coverage.
- Reapply water or maintain covers, as necessary to maintain their effectiveness.

Pictures



Water being applied for dust control.

EROSION CONTROL AND SOIL STABILIZATION

Dust (Wind Erosion) Control



This page intentionally left blank.

BMP	Best Management Practice
BASE	Construction and Operations Center (The Gas Company)
C&O Center	Construction and Operations Center (SDG&E)
Caltrans	California Department of Transportation
Discharger	Any person who discharges waste that could affect the quality of California waters.
DSA	Disturbed Soil Area
EP	Environmental Practice
FCD	Formal Communication Document
Non-rainy Season	May 1 to October 1, except for Southern California Desert Area where the non-rainy season ends August 1.
Rainy Season	October 1 through May 1, except for Southern California Desert Area where the rainy season starts on August 1.
RWQCB	Regional Water Quality Control Boards (RWQCB) – nine Water Boards located throughout California that are responsible for enforcing water quality standards within their boundaries.
Runoff	Rainfall or snow melt that is not absorbed by soil, evaporated, or transpired by plants, but finds its way into streams as surface flow.
ROW	Right of Way
SCG	Southern California Gas Company (The Gas Company)
SDG&E	San Diego Gas and Electric Company
SWRCB	State Water Resources Control Board (SWRCB) – The State Board responsible for protecting and preserving water quality and water rights in California.
SEU	Sempra Energy Utilities
SWPPP	Storm Water Pollution Prevention Plan
Watershed	The total land area that contributes water to a river, stream, lake, or other body of water. Synonymous with drainage area, drainage basin.

This page intentionally left blank.

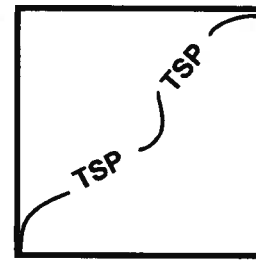
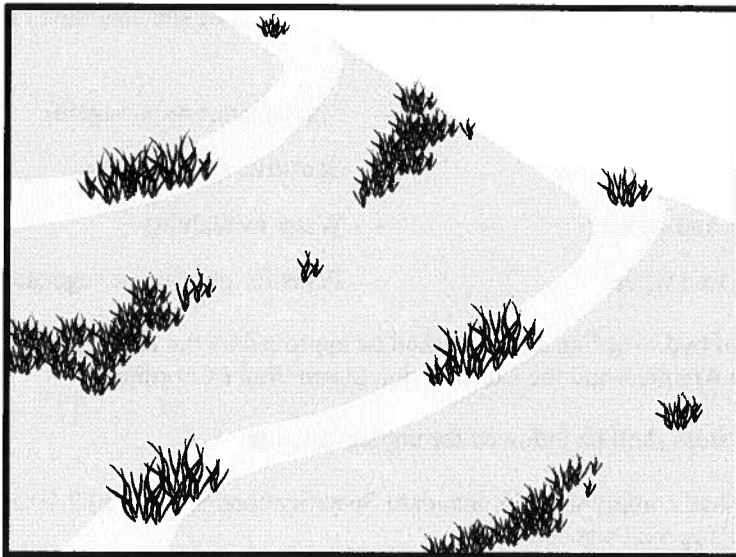

Standard Symbol

BMP Objectives

- Soil Stabilization
- Sediment Control
- Tracking Control
- Wind Erosion Control
- Non-Storm Water Management
- Materials and Waste Management

Definition and Purpose Hydroseeding typically consists of applying a mixture of wood fiber, seed, fertilizer, and stabilizing emulsion with hydro-mulch equipment, which temporarily protects exposed soils from erosion by water and wind. This is one of five temporary soil stabilization alternatives to consider.

Appropriate Applications ■ Hydroseeding is applied on disturbed soil areas requiring temporary protection until permanent vegetation is established or disturbed soil areas that must be re-disturbed following an extended period of inactivity.

- Limitations** ■ Hydroseeding may be used alone only when there is sufficient time in the season to ensure adequate vegetation establishment and erosion control. Otherwise, hydroseeding must be used in conjunction with a soil binder or mulching (i.e., straw mulch), refer to BMP SS-5, Table 1 for options.
- Steep slopes are difficult to protect with temporary seeding.
 - Temporary seeding may not be appropriate in dry periods without supplemental irrigation.
 - Temporary vegetation may have to be removed before permanent vegetation is applied.
 - Temporary vegetation is not appropriate for short-term inactivity.

Standards and Specifications To select appropriate hydroseeding mixtures, an evaluation of site conditions shall be performed with respect to:

- Soil conditions
 - Site topography
 - Season and climate
 - Vegetation types
 - Maintenance requirements
 - Sensitive adjacent areas
 - Water availability
 - Plans for permanent vegetation
- Selection of hydroseeding mixtures shall be approved by the District Landscape Architect and the Construction Storm Water Coordinator.

The following steps shall be followed for implementation:

- Seed mix shall comply with the Standard Specifications Section 20-2.10, and the project's special provisions.
- Hydroseeding can be accomplished using a multiple-step or one-step process; refer to the special provisions for specified process. The multiple-step process ensures maximum direct contact of the seeds to soil. When the one-step process is used to apply the mixture of fiber, seed, etc., the seed rate shall be increased to compensate for all seeds not having direct contact with the soil.
- Prior to application, roughen the slope, fill area, or area to be seeded with the furrows trending along the contours. Rolling with a crimping or punching type roller or track walking is required on all slopes prior to hydroseeding. Track walking shall only be used where other methods are impractical.
- Apply a straw mulch to keep seeds in place and to moderate soil moisture and temperature until the seeds germinate and grow, refer to Standard Specifications Sections 20-2.06 and 20-3.03.
- All seeds shall be in conformance with the California State Seed Law of the Department of Agriculture. Each seed bag shall be delivered to the site sealed and clearly marked as to species, purity, percent germination, dealer's guarantee, and dates of test; provide the Resident Engineer (RE) with such documentation. The container shall be labeled to clearly reflect the amount of Pure Live Seed (PLS) contained. All legume seed shall be pellet-inoculated. Inoculant sources shall be species-specific and shall be applied at a rate of 2 kg of inoculant per 100 kg of seed (2-lb inoculant per 100-lb seed), refer to Standard Specifications Section 20-2.10.
- Commercial fertilizer shall conform to the requirements of the California Food and Agricultural Code. Fertilizer shall be pelleted or granular form.

- Follow-up applications shall be made as needed to cover weak spots, and to maintain adequate soil protection.
 - Avoid over-spray onto the traveled way, sidewalks, lined drainage channels, and existing vegetation.
- Maintenance and Inspection
- All seeded areas shall be inspected for failures and re-seeded, fertilized, and mulched within the planting season, using not less than half the original application rates. Any temporary revegetation efforts that do not provide adequate cover must be reapplied at a scheduled recommended by the Caltrans Landscape Architect or RE.
 - After any rainfall event, the Contractor is responsible for maintaining all slopes to prevent erosion.

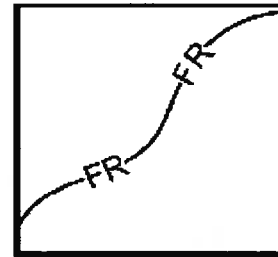

Standard Symbol

BMP Objectives

- Soil Stabilization
- Sediment Control
- Tracking Control
- Wind Erosion Control
- Non-Storm Water Management
- Materials and Waste Management

Definition and Purpose

A fiber roll consists of wood excelsior, rice or wheat straw, or coconut fibers that is rolled or bound into a tight tubular roll and placed on the toe and face of slopes to intercept runoff, reduce its flow velocity, release the runoff as sheet flow and provide removal of sediment from the runoff. Fiber rolls may also be used for inlet protection and as check dams under certain situations.

Appropriate Applications

- This BMP may be implemented on a project-by-project basis with other BMPs when determined necessary and feasible by the RE.
- Along the toe, top, face, and at grade breaks of exposed and erodible slopes to shorten slope length and spread runoff as sheet flow.
- Below the toe of exposed and erodible slopes.
- Fiber rolls may be used as check dams in unlined ditches if approved by the Resident Engineer (RE) or the District Construction Storm Water Coordinator (refer to SC-4 “Check Dams”).
- Fiber rolls may be used for drain inlet protection if approved by the RE or the District Construction Storm Water Coordinator (refer to SC-10 “Storm Drain Inlet Protection”).
- Down-slope of exposed soil areas.
- Around temporary stockpiles.
- Along the perimeter of a project.

- Limitations
- Runoff and erosion may occur if fiber roll is not adequately trenched in.
 - Fiber rolls at the toe of slopes greater than 1:5 may require the use of 500 mm (20" diameter) or installations achieving the same protection (i.e., stacked smaller diameter fiber rolls, etc.).
 - Fiber rolls may be used for drainage inlet protection if they can be properly anchored.
 - Difficult to move once saturated.
 - Fiber rolls could be transported by high flows if not properly staked and trenched in.
 - Fiber rolls have limited sediment capture zone.
 - Do not use fiber rolls on slopes subject to creep, slumping, or landslide.

Standards and Specifications

Fiber Roll Materials

- Fiber rolls shall be either:
 - (1) Prefabricated rolls.
 - (2) Rolled tubes of erosion control blanket.

Assembly of Field Rolled Fiber Roll

- Roll length of erosion control blanket into a tube of minimum 200 mm (8 in) diameter.
- Bind roll at each end and every 1.2 m (4 ft) along length of roll with jute-type twine.

Installation

- Slope inclination of 1:4 or flatter: fiber rolls shall be placed on slopes 6.0 m apart.
- Slope inclination of 1:4 to 1:2: fiber rolls shall be placed on slopes 4.5 m apart.
- Slope inclination 1:2 or greater: fiber rolls shall be placed on slopes 3.0 m apart.
- Stake fiber rolls into a 50 to 100 mm (2 to 4 in) trench.

- Drive stakes at the end of each fiber roll and spaced 600 mm (2 ft) apart if Type 2 installation is used (refer to Page 4). Otherwise, space stakes 1.2 m (4 ft) maximum on center if installed as shown on Pages 5 and 6.
- Use wood stakes with a nominal classification of 19 by 19 mm (3/4 by 3/4 in), and minimum length of 600 mm (24 in).
- If more than one fiber roll is placed in a row, the rolls shall be overlapped; not abutted.

Removal

- Fiber rolls are typically left in place.
- If fiber rolls are removed, collect and dispose of sediment accumulation, and fill and compact holes, trenches, depressions or any other ground disturbance to blend with adjacent ground.

Maintenance and Inspection

- Repair or replace split, torn, unraveling, or slumping fiber rolls.
- Inspect fiber rolls when rain is forecast. Perform maintenance as needed or as required by the RE.
- Inspect fiber rolls following rainfall events and a least daily during prolonged rainfall. Perform maintenance as needed or as required by the RE.
- Maintain fiber rolls to provide an adequate sediment holding capacity. Sediment shall be removed when the sediment accumulation reaches three quarters (3/4) of the barrier height. Removed sediment shall be incorporated in the project at locations designated by the RE or disposed of outside the highway right-of-way in conformance with the Standard Specifications.

Fiber Rolls

SC-5

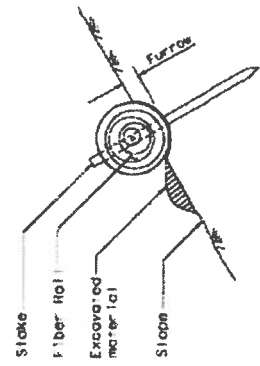

SECTION
TEMPORARY FIBER ROLL
(TYPE 1)

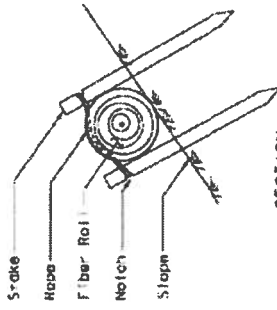

SECTION

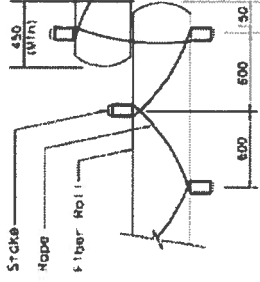

PLAN
TEMPORARY FIBER ROLL
(TYPE 2)

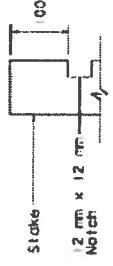

ELEVATION
NOTCH DETAIL

NOTE
1. Temporary fiber roll spacing varies depending upon abutts inclination.

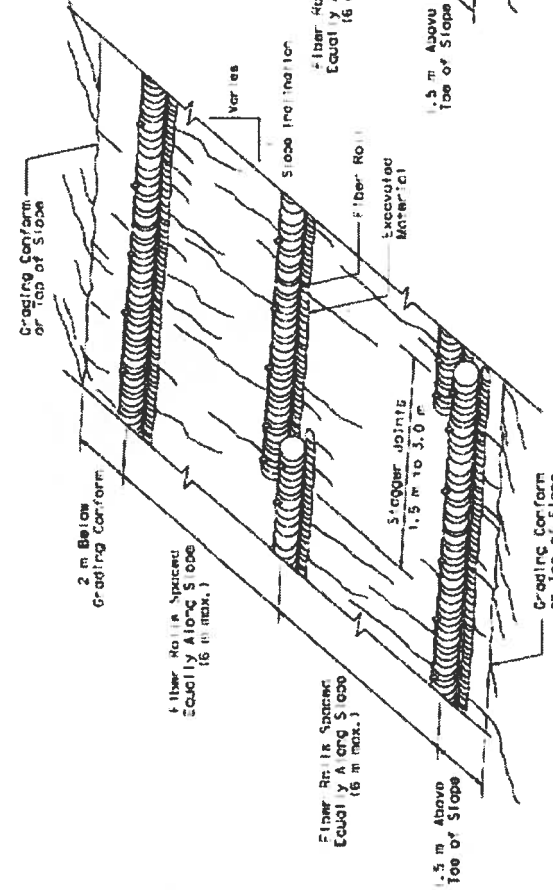

PERSPECTIVE

TEMPORARY FIBER ROLL (TYPE 1)

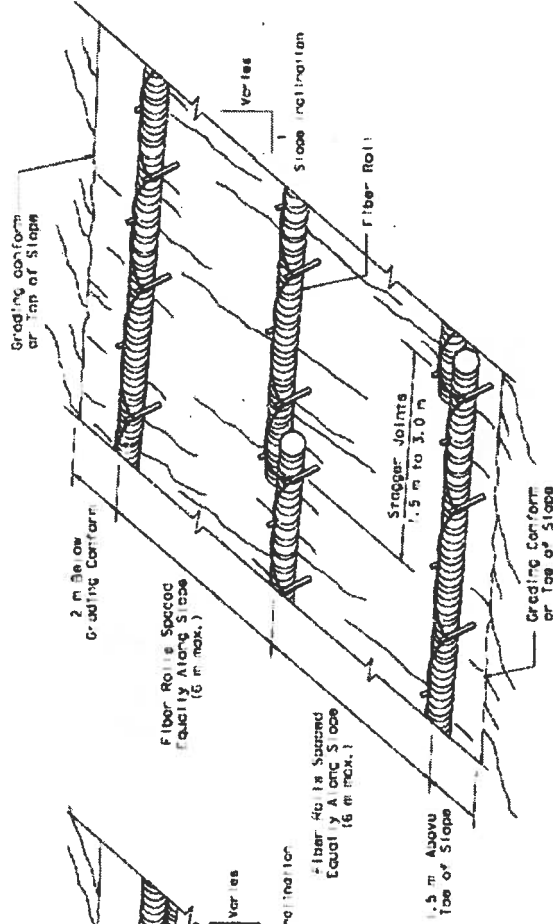

PERSPECTIVE

TEMPORARY FIBER ROLL (TYPE 2)



Fiber Rolls

SC-5

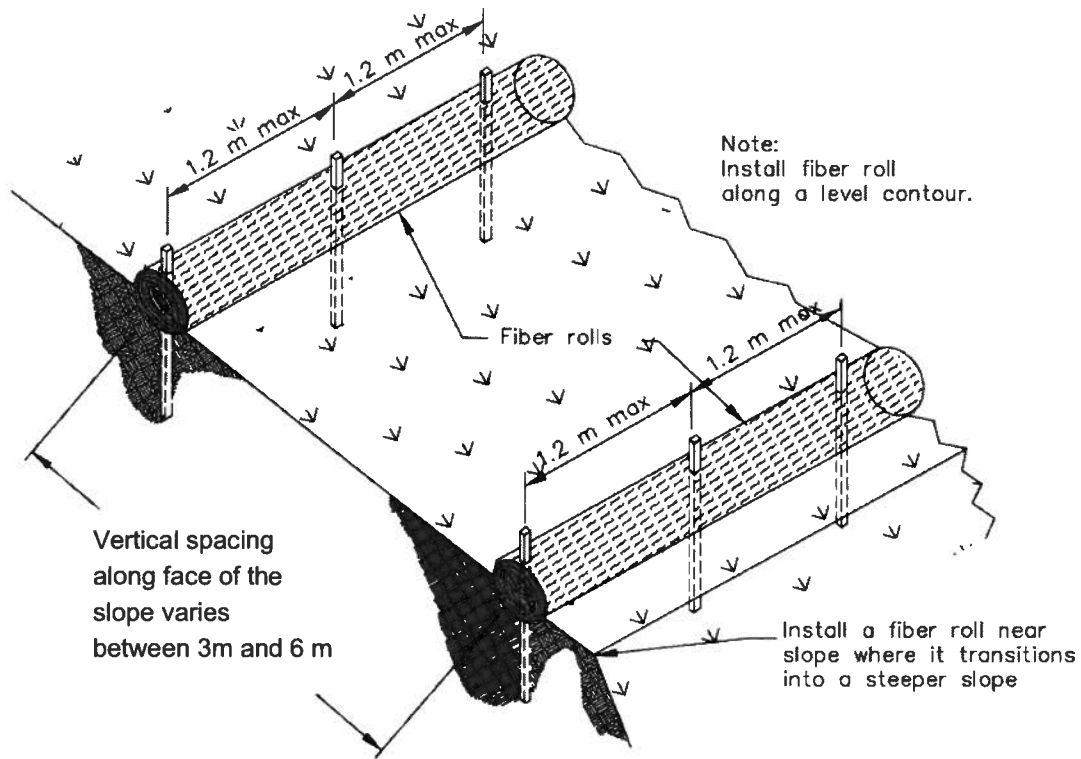

TYPICAL FIBER ROLL INSTALLATION

N.T.S.

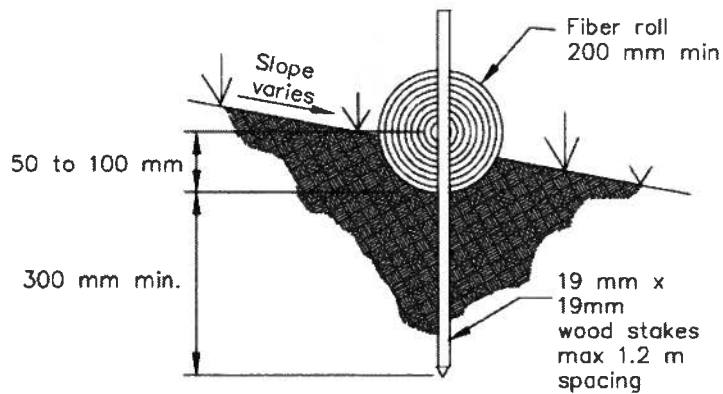

ENTRENCHMENT DETAIL

N.T.S.

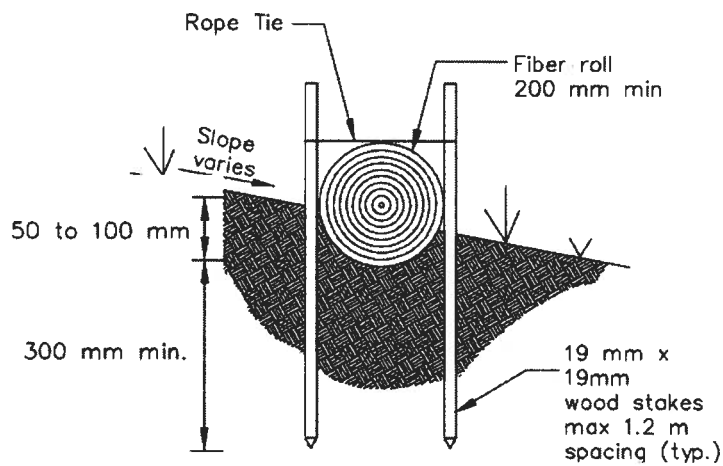
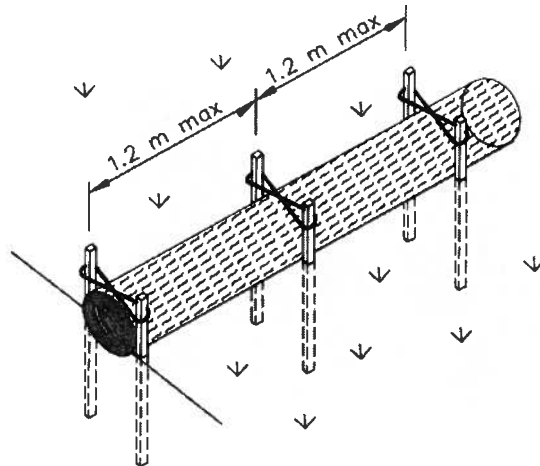

OPTIONAL ENTRENCHMENT DETAIL

N.T.S.

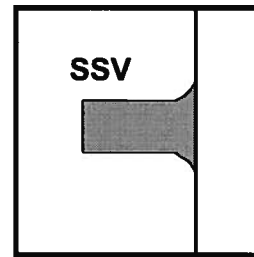
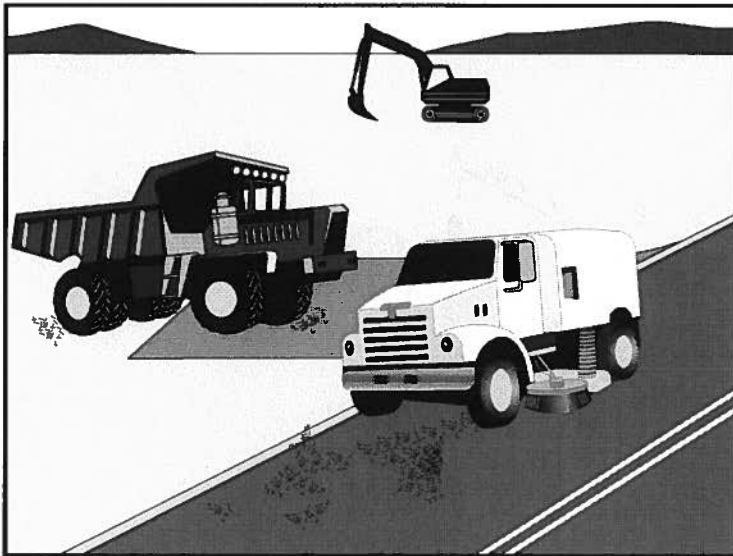

Standard Symbol

BMP Objectives

- Soil Stabilization
- Sediment Control
- Tracking Control
- Wind Erosion Control
- Non-Storm Water Management
- Materials and Waste Management

Definition and Purpose Practices to remove tracked sediment to prevent the sediment from entering a storm drain or watercourse.

Appropriate Applications These practices are implemented anywhere sediment is tracked from the project site onto public or private paved roads, typically at points of ingress/egress.

Limitations Sweeping and vacuuming may not be effective when soil is wet or muddy.

Standards and Specifications

- Kick brooms or sweeper attachments shall not be used.
- Inspect potential sediment tracking locations daily.
- Visible sediment tracking shall be swept and/or vacuumed daily.
- If not mixed with debris or trash, consider incorporating the removed sediment back into the project.

Maintenance and Inspection

- Inspect ingress/egress access points daily and sweep tracked sediment as needed, or as required by the Resident Engineer (RE).
- Be careful not to sweep up any unknown substance or any object that may be potentially hazardous.
- Adjust brooms frequently; maximize efficiency of sweeping operations.
- After sweeping is finished, properly dispose of sweeper wastes at an approved dumpsite in conformance with the provisions in Standard Specifications Section 7-1.13 .

Storm Drain Inlet Protection

SC-10

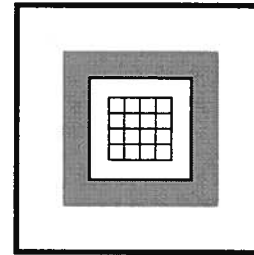
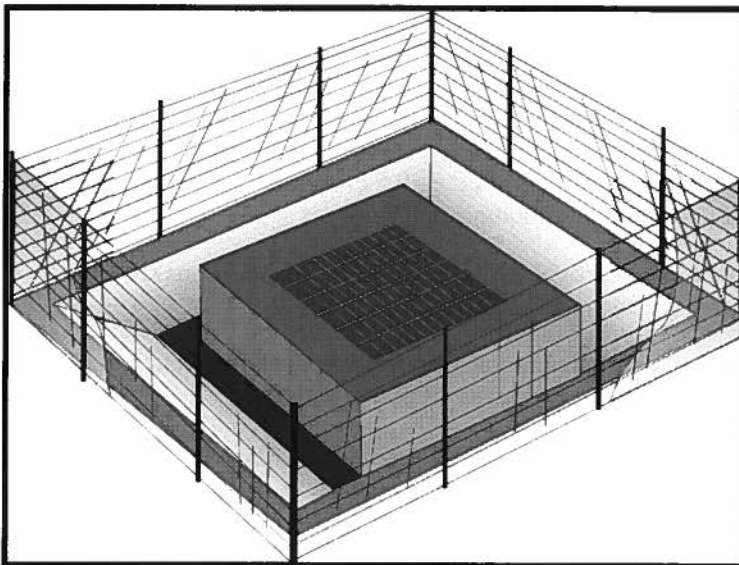

Standard Symbol

BMP Objectives

- Soil Stabilization
- Sediment Control
- Tracking Control
- Wind Erosion Control
- Non-Storm Water Management
- Materials and Waste Management

Definition and Purpose Devices used at storm drain inlets that are subject to runoff from construction activities to detain and/or to filter sediment-laden runoff to allow sediment to settle and/or to filter sediment prior to discharge into storm drainage systems or watercourses.

- Appropriate Applications**
- Where ponding will not encroach into highway traffic.
 - Where sediment laden surface runoff may enter an inlet.
 - Where disturbed drainage areas have not yet been permanently stabilized.
 - Where the drainage area is 0.4 ha (1 ac) or less.
 - Appropriate during wet and snow-melt seasons.

- Limitations**
- Requires an adequate area for water to pond without encroaching upon traveled way and should not present itself to be an obstacle to oncoming traffic.
 - May require other methods of temporary protection to prevent sediment-laden storm water and non-storm water discharges from entering the storm drain system.
 - Sediment removal may be difficult in high flow conditions or if runoff is heavily sediment laden. If high flow conditions are expected, use other on-site sediment trapping techniques (e.g. check dams) in conjunction with inlet protection.
 - Frequent maintenance is required.
 - For drainage areas larger than 0.4 ha (1 ac), runoff shall be routed to a sediment trapping device designed for larger flows. See BMPs SC-2, "Sediment/Desilting Basin," and SC-3 "Sediment Trap."



- Filter fabric fence inlet protection is appropriate in open areas that are subject to sheet flow and for flows not exceeding 0.014 m³/s (0.5 cfs).
- Gravel bag barriers for inlet protection are applicable when sheet flows or concentrated flows exceed 0.014 m³/s (0.5 cfs), and it is necessary to allow for overtopping to prevent flooding.
- Fiber rolls and foam barriers are not appropriate for locations where they cannot be properly anchored to the surface.
- Excavated drop inlet sediment traps are appropriate where relatively heavy flows are expected and overflow capability is needed.

Standards and Specifications

Identify existing and/or planned storm drain inlets that have the potential to receive sediment-laden surface runoff. Determine if storm drain inlet protection is needed, and which method to use.

Methods and Installation

- **DI Protection Type 1 - Filter Fabric Fence** - The filter fabric fence (Type 1) protection is illustrated on Page 5. Similar to constructing a silt fence. See BMP SC-1, "Silt Fence." Do not place filter fabric underneath the inlet grate since the collected sediment may fall into the drain inlet when the fabric is removed or replaced.
- **DI Protection Type 2 - Excavated Drop Inlet Sediment Trap** - The excavated drop inlet sediment trap (Type 2) is illustrated in Page 6. Similar to constructing a temporary silt fence, See BMP SC-1, "Silt Fence." Size excavated trap to provide a minimum storage capacity calculated at the rate of 130 m³/ha (67 yd³/ac) of drainage area.
- **DI Protection Type 3 - Gravel bag** - The gravel bag barrier (Type 3) is illustrated in Page 7. Flow from a severe storm shall not overtop the curb. In areas of high clay and silts, use filter fabric and gravel as additional filter media. Construct gravel bags in accordance with BMP SC-6, "Gravel Bag Berm." Gravel bags shall be used due to their high permeability.
- **DI Protection Type 4 - Foam Barriers and Fiber Rolls** - Foam barrier or fiber roll (Type 4) is placed around the inlet and keyed and anchored to the surface. Foam barriers and fiber rolls are intended for use as inlet protection where the area around the inlet is unpaved and the foam barrier or fiber roll can be secured to the surface. RE or Construction Storm Water Coordinator approval is required.

Maintenance and Inspection

General

- Inspect all inlet protection devices before and after every rainfall event, and weekly during the rest of the rainy season. During extended rainfall events, inspect inlet protection devices at least once every 24 hours.

- Inspect the storm drain inlet after severe storms in the rainy season to check for bypassed material.
- Remove all inlet protection devices within thirty days after the site is stabilized, or when the inlet protection is no longer needed.
 - Bring the disturbed area to final grade and smooth and compact it. Appropriately stabilize all bare areas around the inlet.
 - Clean and re-grade area around the inlet and clean the inside of the storm drain inlet as it must be free of sediment and debris at the time of final inspection.

Requirements by Method

■ **Type 1 - Filter Fabric Fence**

- This method shall be used for drain inlets requiring protection in areas where finished grade is established and erosion control seeding has been applied or is pending.
- Make sure the stakes are securely driven in the ground and are structurally sound (i.e., not bent, cracked, or splintered, and are reasonably perpendicular to the ground). Replace damaged stakes.
- Replace or clean the fabric when the fabric becomes clogged with sediment. Make sure the fabric does not have any holes or tears. Repair or replace fabric as needed or as directed by the RE.
- At a minimum, remove the sediment behind the fabric fence when accumulation reaches one-third the height of the fence or barrier height. Removed sediment shall be incorporated in the project at locations designated by the RE or disposed of outside the highway right-of-way in conformance with the Standard Specifications Section 7-1.13.

■ **Type 2 – Excavated Drop Inlet Sediment Trap**

- This method may be used for drain inlets requiring protection in areas that have been cleared and grubbed, and where exposed soil areas are subject to grading.
- Remove sediment from basin when the volume of the basin has been reduced by one-half.

■ **Type 3 - Gravel Bag Barrier**

- This method may be used for drain inlets surrounded by AC or paved surfaces.
- Inspect bags for holes, gashes, and snags.

- Check gravel bags for proper arrangement and displacement. Remove the sediment behind the barrier when it reaches one-third the height of the barrier. Removed sediment shall be incorporated in the project at locations designated by the RE or disposed of outside the highway right-of-way in conformance with the Standard Specifications Section 7-1.13.

■ ***Type 4 Foam Barriers and Fiber Rolls***

- This method may be used for drain inlets requiring protection in areas that have been cleared and grubbed, and where exposed soil areas subject to grading. RE or Construction Storm Coordinator approval is required.
- Check foam barrier or fiber roll for proper arrangement and displacement. Remove the sediment behind the barrier when it reaches one-third the height of the barrier. Removed sediment shall be incorporated in the project at locations designated by the RE or disposed of outside the highway right-of-way in conformance with the Standard Specifications.

Storm Drain Inlet Protection

SC-10

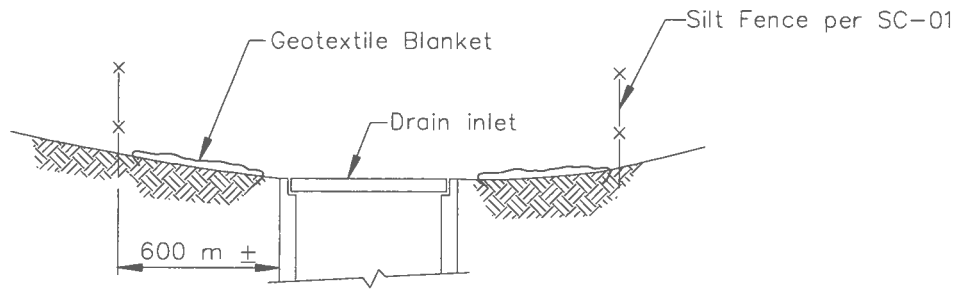

SECTION A-A

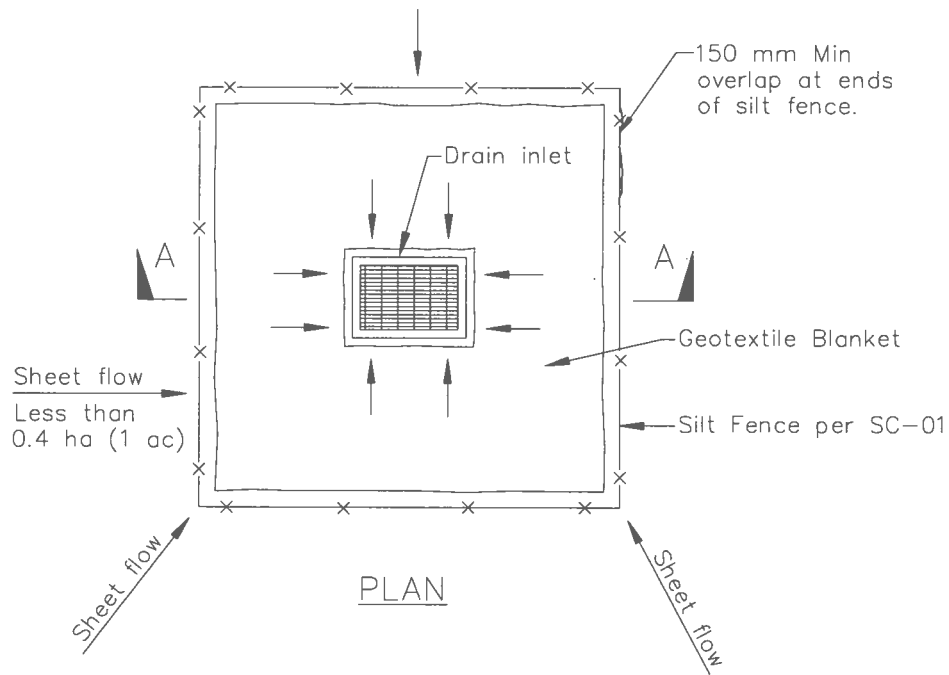

PLAN

DI PROTECTION TYPE 1
NOT TO SCALE

NOTES:

1. For use in areas where grading has been completed and final soil stabilization and seeding are pending.
2. Not applicable in paved areas.
3. Not applicable with concentrated flows.

Storm Drain Inlet Protection

SC-10

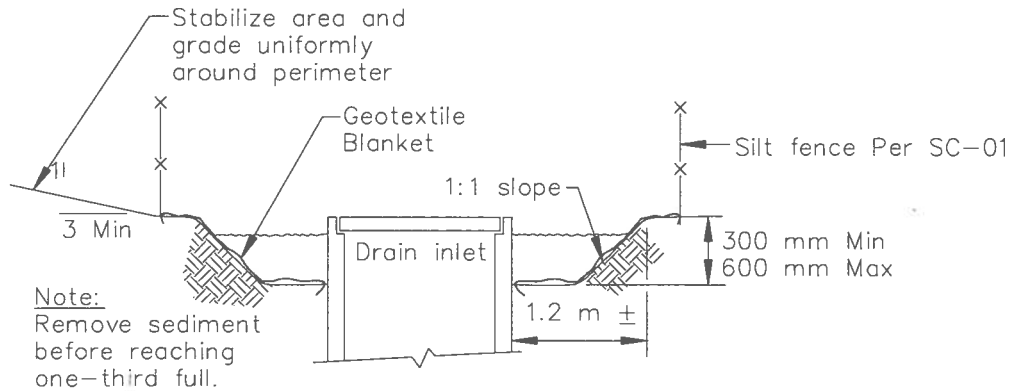

Section A-A

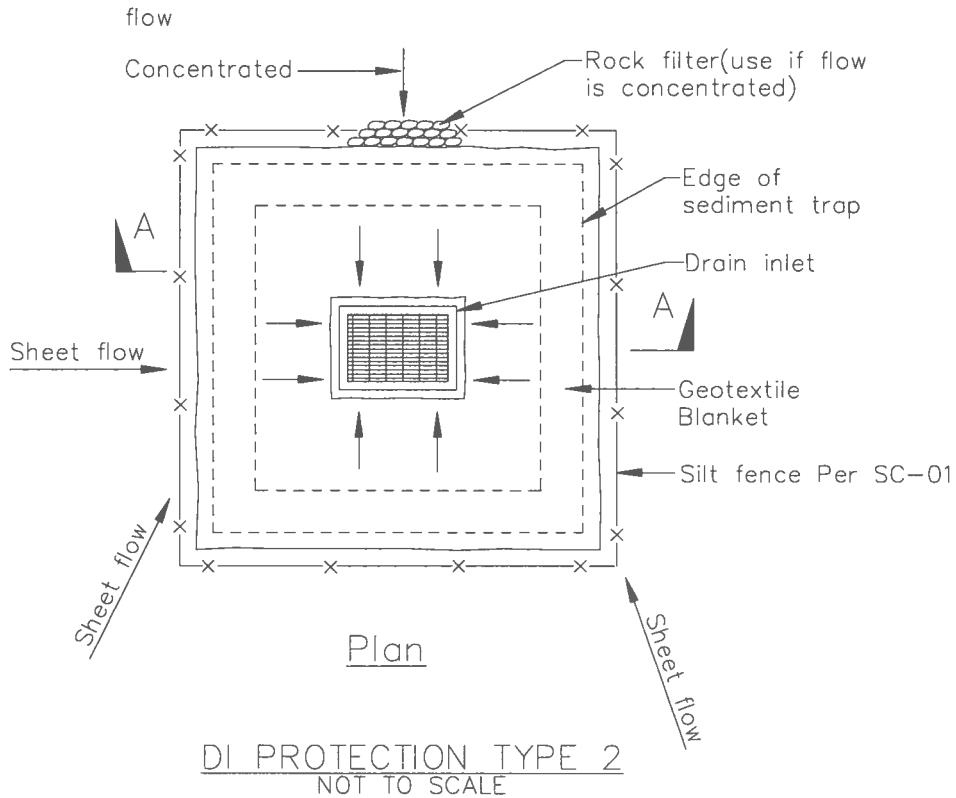

Notes

1. For use in cleared and grubbed and in graded areas.
2. Shape basin so that longest inflow area faces longest length of trap.
3. For concentrated flows, shape basin in 2:1 ratio with length oriented towards direction of flow.



Storm Drain Inlet Protection

SC-10

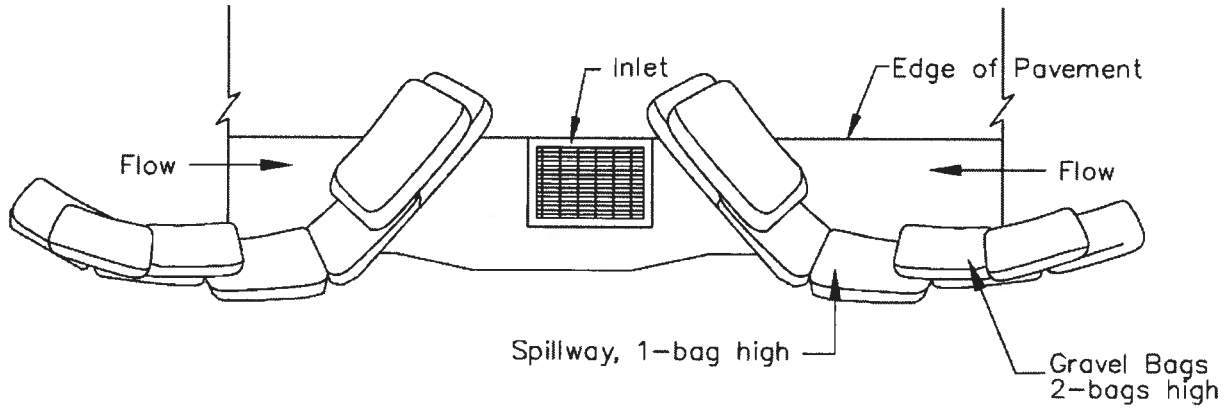

TYPICAL PROTECTION FOR INLET WITH OPPOSING FLOW DIRECTIONS

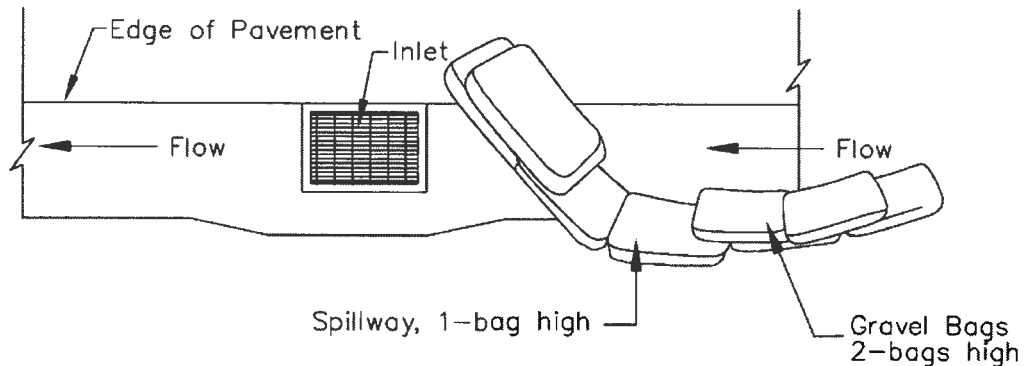

TYPICAL PROTECTION FOR INLET WITH SINGLE FLOW DIRECTION

NOTES:

1. Intended for short-term use.
2. Use to inhibit non-storm water flow.
3. Allow for proper maintenance and cleanup.
4. Bags must be removed after adjacent operation is completed
5. Not applicable in areas with high silts and clays without filter fabric.



Stabilized Construction Entrance/Exit **TC-1**

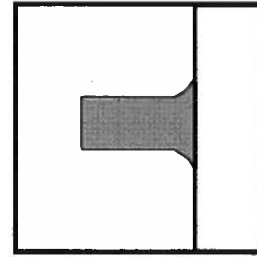
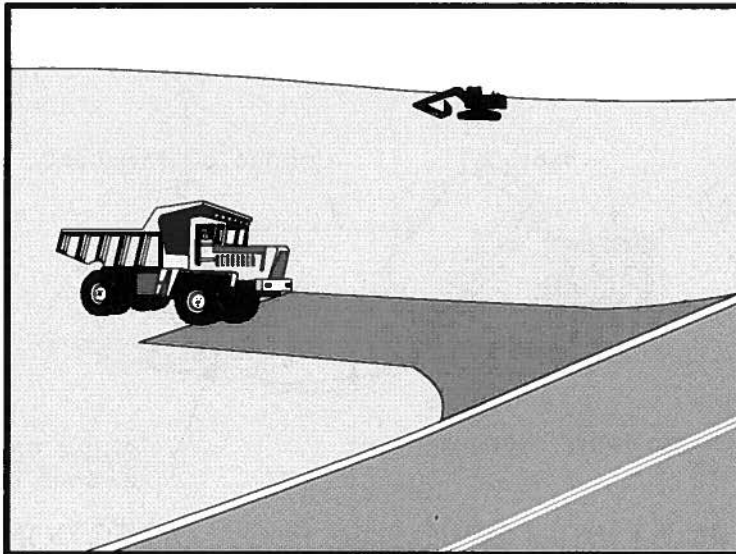

Standard Symbol

BMP Objectives

- Soil Stabilization
- Sediment Control
- Tracking Control
- Wind Erosion Control
- Non-Storm Water Management
- Materials and Waste Management

Definition and Purpose A stabilized construction access is defined by a point of entrance/exit to a construction site that is stabilized to reduce the tracking of mud and dirt onto public roads by construction vehicles.

Appropriate Applications

- Use at construction sites:
 - Where dirt or mud can be tracked onto public roads.
 - Adjacent to water bodies.
 - Where poor soils are encountered.
 - Where dust is a problem during dry weather conditions.
- This BMP may be implemented on a project-by-project basis in addition to other BMPs when determined necessary and feasible by the Resident Engineer (RE).

Limitations

- Site conditions will dictate design and need.

Standards and Specifications

- Limit the points of entrance/exit to the construction site.
- Limit speed of vehicles to control dust.
- Properly grade each construction entrance/exit to prevent runoff from leaving the construction site.
- Route runoff from stabilized entrances/exits through a sediment-trapping device before discharge.
- Design stabilized entrance/exit to support the heaviest vehicles and equipment that will use it.

- Select construction access stabilization (aggregate, asphaltic concrete, concrete) based on longevity, required performance, and site conditions. The use of asphalt concrete (AC) grindings for stabilized construction access/roadway is not allowed.
 - Use of constructed/manufactured steel plates with ribs for entrance/exit access is allowed with written approval from the RE.
 - If aggregate is selected, place crushed aggregate over geotextile fabric to at least 300 mm (12 in) depth, or place aggregate to a depth recommended by the RE. Crushed aggregate greater than 75 mm (3 inches) and smaller than 150 mm (6 inches) shall be used.
 - Designate combination or single purpose entrances and exits to the construction site.
 - Implement BMP SC-7, "Street Sweeping and Vacuuming" as needed and as required.
 - Require all employees, subcontractors, and suppliers to utilize the stabilized construction access.
 - All exit locations intended to be used continuously and for a period of time shall have stabilized construction entrance/exit BMPs (TC-1 "Stabilized Construction Entrance/Exit" or TC-3 "Entrance/Outlet Tire Wash").
- Maintenance and Inspection**
- Inspect routinely for damage and assess effectiveness of the BMP. Remove aggregate, separate and dispose of sediment if construction entrance/exit is clogged with sediment or as directed by the RE.
 - Keep all temporary roadway ditches clear.
 - Inspect for damage and repair as needed.

Stabilized Construction Entrance/Exit TC-1

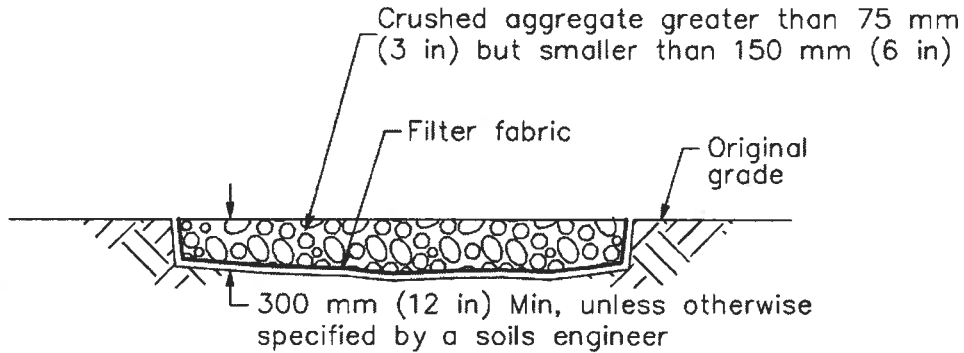

SECTION B-B
NTS

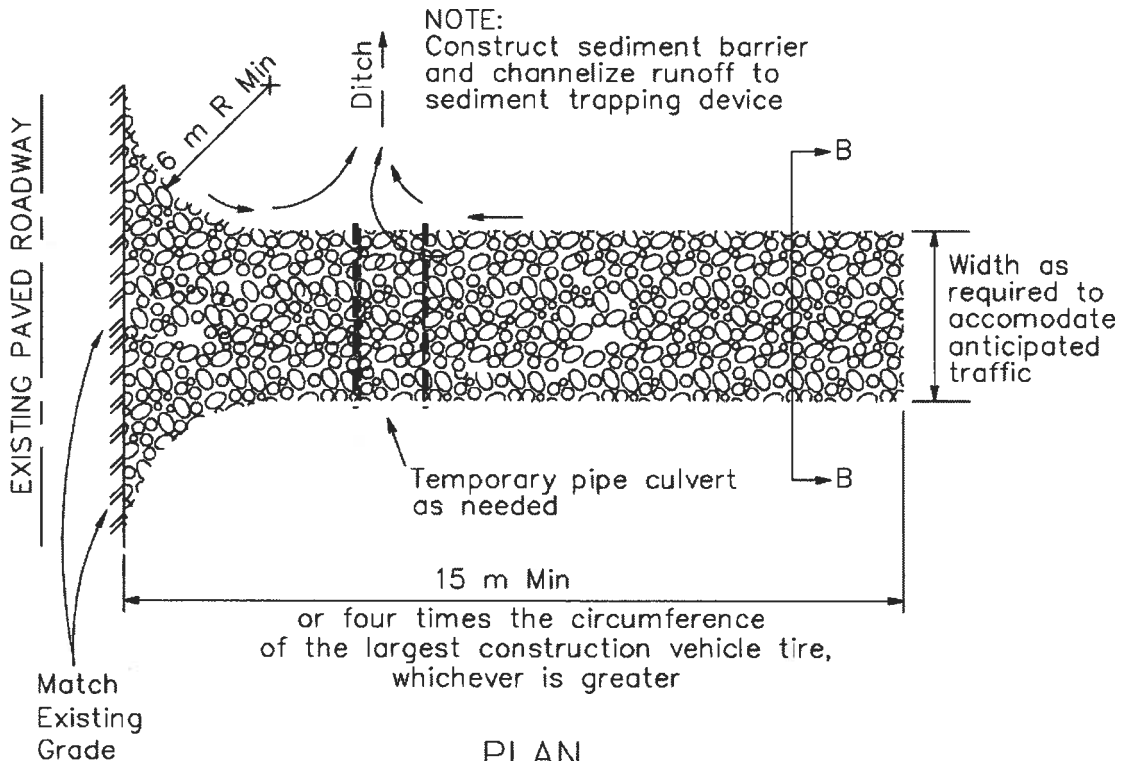

PLAN
NTS

Stabilized Construction Entrance/Exit (Type 1)

Stabilized Construction Entrance/Exit

TC-1

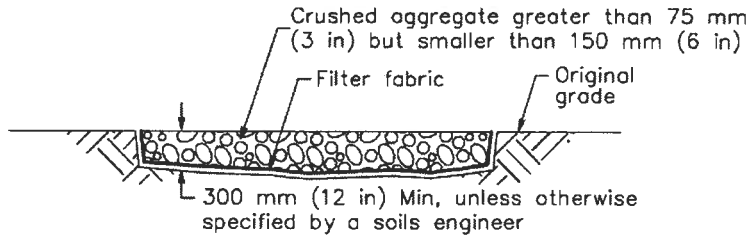

SECTION B-B
NTS

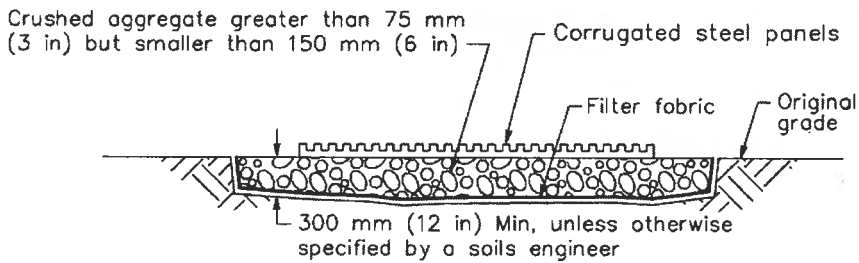

SECTION A-A
NOT TO SCALE

NOTE:
Construct sediment barrier and channelize runoff to sediment trapping device

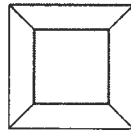

Sediment trapping device

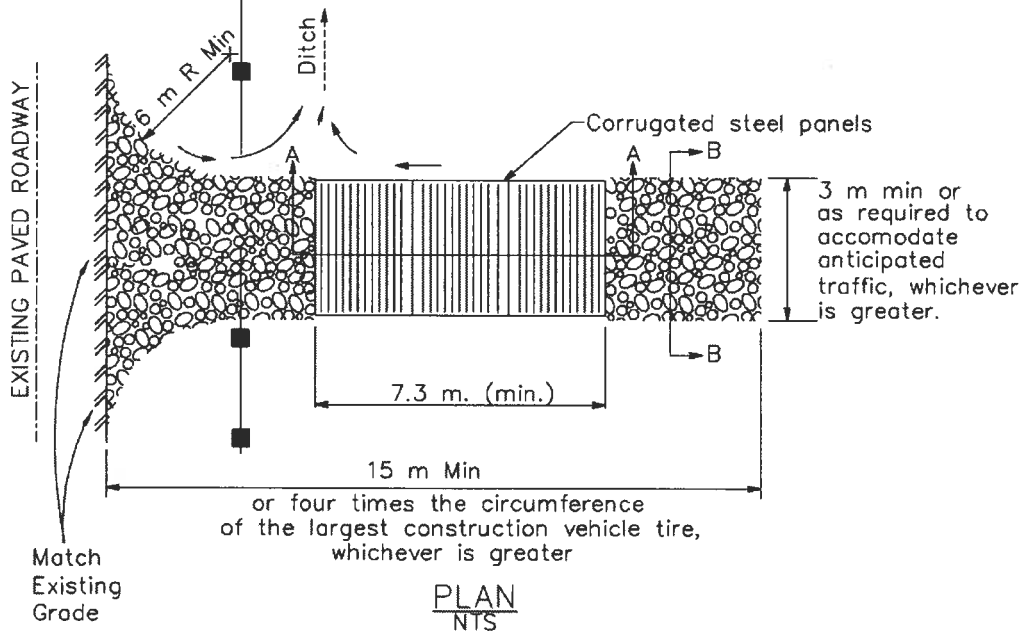

Stabilized Construction Entrance/Exit (Type 2)



Vehicle and Equipment Fueling

NS-9

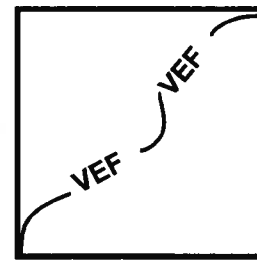
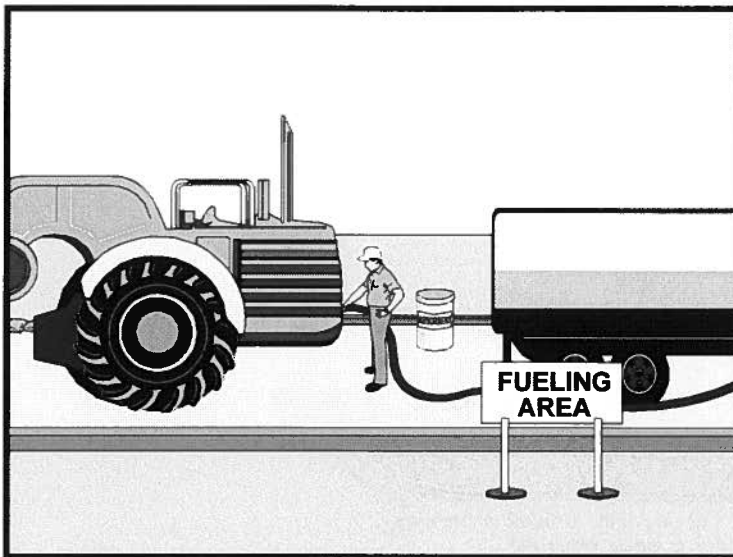

Standard Symbol

BMP Objectives

- Soil Stabilization
- Sediment Control
- Tracking Control
- Wind Erosion Control
- Non-Storm Water Management
- Materials and Waste Management

Definition and Purpose Vehicle and equipment fueling procedures and practices are designed to minimize or eliminate the discharge of fuel spills and leaks into storm drain systems or to watercourses.

Appropriate Applications These procedures are applied on all construction sites where vehicle and equipment fueling takes place.

Limitations

- Onsite vehicle and equipment fueling shall only be used where it's impractical to send vehicles and equipment off-site for fueling.

Standards and Specifications

- When fueling must occur onsite, the contractor shall select and designate an area to be used, subject to approval of the Resident Engineer (RE).
- Absorbent spill clean-up materials and spill kits shall be available in fueling areas and on fueling trucks and shall be disposed of properly after use.
- Drip pans or absorbent pads shall be used during vehicle and equipment fueling, unless the fueling is performed over an impermeable surface in a dedicated fueling area.
- Dedicated fueling areas shall be protected from storm water run-on and runoff, and shall be located at least 15 m (50 ft) from downstream drainage facilities and watercourses. Fueling must be performed on level-grade areas.
- Nozzles used in vehicle and equipment fueling shall be equipped with an automatic shut-off to control drips. Fueling operations shall not be left unattended.
- Protect fueling areas with berms and/or dikes to prevent run-on, runoff, and to contain spills.

Vehicle and Equipment Fueling

NS-9

- Use vapor recovery nozzles to help control drips as well as air pollution where required by Air Quality Management Districts (AQMD). Ensure the nozzle is secured upright when not in use.
 - Fuel tanks shall not be "topped-off."
 - Vehicles and equipment shall be inspected on each day of use for leaks. Leaks shall be repaired immediately or problem vehicles or equipment shall be removed from the project site.
 - Absorbent spill clean-up materials shall be available in fueling and maintenance areas and used on small spills instead of hosing down or burying techniques. The spent absorbent material shall be removed promptly and disposed of properly.
 - Federal, state, and local requirements shall be observed for any stationary above ground storage tanks. Refer to WM-1, "Material Delivery and Storage."
 - Mobile fueling of construction equipment throughout the site shall be minimized. Whenever practical, equipment shall be transported to the designated fueling area.
- Maintenance and Inspection
- Fueling areas and storage tanks shall be inspected regularly.
 - Keep an ample supply of spill cleanup material on the site.
 - Immediately cleanup spills and properly dispose of contaminated soil and cleanup materials.



Material Delivery and Storage

WM-1

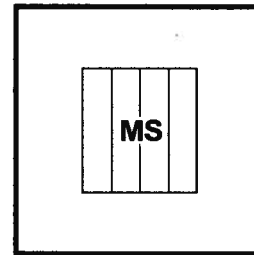
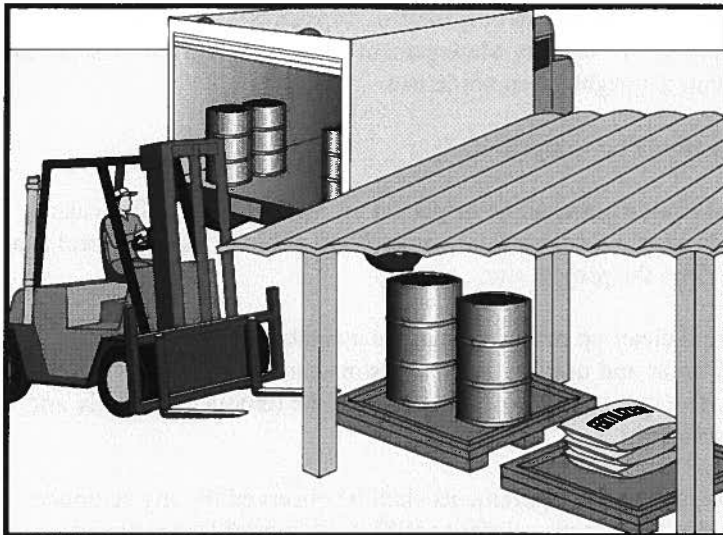

Standard Symbol

BMP Objectives

- Soil Stabilization
- Sediment Control
- Tracking Control
- Wind Erosion Control
- Non-Storm Water Management
- Materials and Waste Management

Definition and Purpose Procedures and practices for the proper handling and storage of materials in a manner that minimizes or eliminates the discharge of these materials to the storm drain system or to watercourses.

Appropriate Applications These procedures are implemented at all construction sites with delivery and storage of the following:

- Hazardous chemicals such as:
 - Acids,
 - lime,
 - glues,
 - adhesives,
 - paints,
 - solvents, and
 - curing compounds.
- Soil stabilizers and binders.
- Fertilizers.
- Detergents.
- Plaster.
- Petroleum products such as fuel, oil, and grease.
- Asphalt and concrete components.
- Pesticides and herbicides.

- Other materials that may be detrimental if released to the environment.

Limitations

- Space limitation may preclude indoor storage.
- Storage sheds must meet building & fire code requirements.

Standards and Specifications

General

- Train employees and subcontractors on the proper material delivery and storage practices.
- Temporary storage area shall be located away from vehicular traffic.
- Material Safety Data Sheets (MSDS) shall be supplied to the Resident Engineer (RE) for all materials stored.

Material Storage Areas and Practices

- Liquids, petroleum products, and substances listed in 40 CFR Parts 110, 117, or 302 shall be stored in approved containers and drums and shall be placed in temporary containment facilities for storage.
- Throughout the rainy season, each temporary containment facility shall have a permanent cover and side wind protection or be covered during non-working days and prior to and during rain events.
- A temporary containment facility shall provide for a spill containment volume able to contain precipitation from a 24-hour, 25-year storm event, plus the greater of 10% of the aggregate volume of all containers or 100% of the capacity of the largest container within its boundary, whichever is greater.
- A temporary containment facility shall be impervious to the materials stored therein for a minimum contact time of 72 hours.
- A temporary containment facility shall be maintained free of accumulated rainwater and spills. In the event of spills or leaks, accumulated rainwater and spills shall be collected and placed into drums. These liquids shall be handled as a hazardous waste unless testing determines them to be non-hazardous. All collected liquids or non-hazardous liquids shall be sent to an approved disposal site.
- Sufficient separation shall be provided between stored containers to allow for spill cleanup and emergency response access.
- Incompatible materials, such as chlorine and ammonia, shall not be stored in the same temporary containment facility.
- Materials shall be stored in their original containers and the original product labels shall be maintained in place in a legible condition. Damaged or otherwise illegible labels shall be replaced immediately.

-
- Bagged and boxed materials shall be stored on pallets and shall not be allowed to accumulate on the ground. To provide protection from wind and rain, throughout the rainy season, bagged and boxed materials shall be covered during non-working days and prior to rain events.
- Stockpiles shall be protected in accordance with BMP WM-3, "Stockpile Management."
- Minimize the material inventory stored on-site (e.g., only a few days supply).
- Have proper storage instructions posted at all times in an open and conspicuous location.
- Do not store hazardous chemicals, drums, or bagged materials directly on the ground. Place these items on a pallet and when possible, under cover in secondary containment.
- Keep hazardous chemicals well labeled and in their original containers.
- Keep ample supply of appropriate spill clean up material near storage areas.
- Also see BMP WM-6, "Hazardous Waste Management", for storing of hazardous materials.

Material Delivery Practices

- Keep an accurate, up-to-date inventory of material delivered and stored on-site.
- Employees trained in emergency spill clean-up procedures shall be present when dangerous materials or liquid chemicals are unloaded.

Spill Clean-up

- Contain and clean up any spill immediately.
- If significant residual materials remain on the ground after construction is complete, properly remove and dispose any hazardous materials or contaminated soil.
- See BMP WM-4, "Spill Prevention and Control", for spills of chemicals and/or hazardous materials.

Material Delivery and Storage

WM-1

Maintenance and Inspection

- Storage areas shall be kept clean, well organized, and equipped with ample clean-up supplies as appropriate for the materials being stored.
- Perimeter controls, containment structures, covers, and liners shall be repaired or replaced as needed to maintain proper function.
- Inspect storage areas before and after rainfall events, and at least weekly during other times. Collect and place into drums any spills or accumulated rainwater.



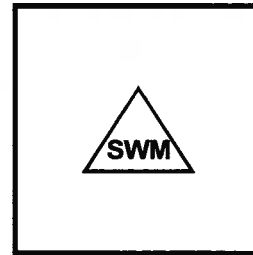
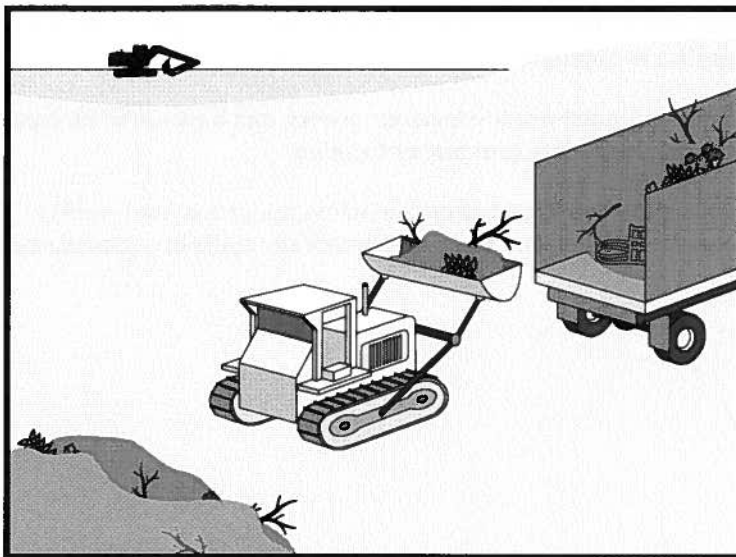

Standard Symbol

BMP Objectives

- Soil Stabilization
- Sediment Control
- Tracking Control
- Wind Erosion Control
- Non-Storm Water Management
- Materials and Waste Management

Definition and Purpose Solid waste management procedures and practices are designed to minimize or eliminate the discharge of pollutants to the drainage system or to watercourses as a result of the creation, stockpiling, or removal of construction site wastes.

Appropriate Applications Solid waste management procedures and practices are implemented on all construction projects that generate solid wastes.

Solid wastes include but are not limited to:

- Construction wastes including brick, mortar, timber, steel and metal scraps, sawdust, pipe and electrical cuttings, non-hazardous equipment parts, styrofoam and other materials used to transport and package construction materials.
- Highway planting wastes, including vegetative material, plant containers, and packaging materials.
- Litter, including food containers, beverage cans, coffee cups, paper bags, plastic wrappers, and smoking materials, including litter generated by the public.

Limitations ■ Temporary stockpiling of certain construction wastes may not necessitate stringent drainage related controls during the non-rainy season or in desert areas with low rainfall.

Standards and Specifications **Education**

- The Contractor's Water Pollution Control Manager (WPCM) shall oversee and enforce proper solid waste procedures and practices.
- Instruct employees and subcontractors on identification of solid waste and hazardous waste.
- Educate employees and subcontractors on solid waste storage and disposal procedures.
- Hold regular meetings to discuss and reinforce disposal procedures (incorporate into regular safety meetings).
- Require that employees and subcontractors follow solid waste handling and storage procedures.
- Prohibit littering by employees, subcontractors, and visitors.
- Wherever possible, minimize production of solid waste materials.

Collection, Storage, and Disposal

- Dumpsters of sufficient size and number shall be provided to contain the solid waste generated by the project and properly serviced.
- Littering on the project site shall be prohibited.
- To prevent clogging of the storm drainage system litter and debris removal from drainage grates, trash racks, and ditch lines shall be a priority.
- Trash receptacles shall be provided in the Contractor's yard, field trailer areas, and at locations where workers congregate for lunch and break periods.
- Construction debris and litter from work areas within the construction limits of the project site shall be collected and placed in watertight dumpsters at least weekly regardless of whether the litter was generated by the Contractor, the public, or others. Collected litter and debris shall not be placed in or next to drain inlets, storm water drainage systems or watercourses.
- Full dumpsters shall be removed from the project site and the contents shall be disposed of outside the highway right-of-way in conformance with the provisions in the Standard Specifications Section 7-1.13.
- Litter stored in collection areas and containers shall be handled and disposed of by trash hauling contractors.
- Construction debris and waste shall be removed from the site every two weeks or as directed by the RE.

- Construction material visible to the public shall be stored or stacked in an orderly manner to the satisfaction of the RE.
- Storm water run-on shall be prevented from contacting stored solid waste through the use of berms, dikes, or other temporary diversion structures or through the use of measures to elevate waste from site surfaces.
- Solid waste storage areas shall be located at least 15 m (50 ft) from drainage facilities and watercourses and shall not be located in areas prone to flooding or ponding.
- Except during fair weather, construction and highway planting waste not stored in watertight dumpsters shall be securely covered from wind and rain by covering the waste with tarps or plastic sheeting or protected in conformance with the applicable Disturbed Soil Area protection section.
- Dumpster washout on the project site is not allowed.
- Notify trash hauling contractors that only watertight dumpsters are acceptable for use on-site.
- Plan for additional containers during the demolition phase of construction.
- Plan for more frequent pickup during the demolition phase of construction.
- Construction waste shall be stored in a designated area approved by the RE.
- Segregate potentially hazardous waste from non-hazardous construction site waste.
- Keep the site clean of litter debris.
- Make sure that toxic liquid wastes (e.g., used oils, solvents, and paints) and chemicals (e.g., acids, pesticides, additives, curing compounds) are not disposed of in dumpsters designated for construction debris.
- Dispose of non-hazardous waste in accordance with Standard Specification 7-1.13, Disposal of Material Outside the Highway Right of Way.
- For disposal of hazardous waste, see BMP WM-6, "Hazardous Waste Management." Have hazardous waste hauled to an appropriate disposal and/or recycling facility.
- Salvage or recycle useful vegetation debris, packaging and/or surplus building materials when practical. For example, trees and shrubs from land clearing can be converted into wood chips, then used as mulch on graded areas. Wood pallets, cardboard boxes, and construction scraps can also be recycled.

- Maintenance and Inspection
- The WPCM shall monitor onsite solid waste storage and disposal procedures.
 - Police site for litter and debris.

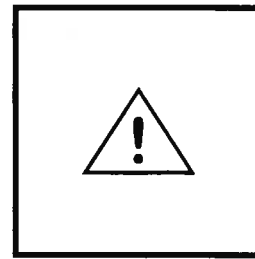
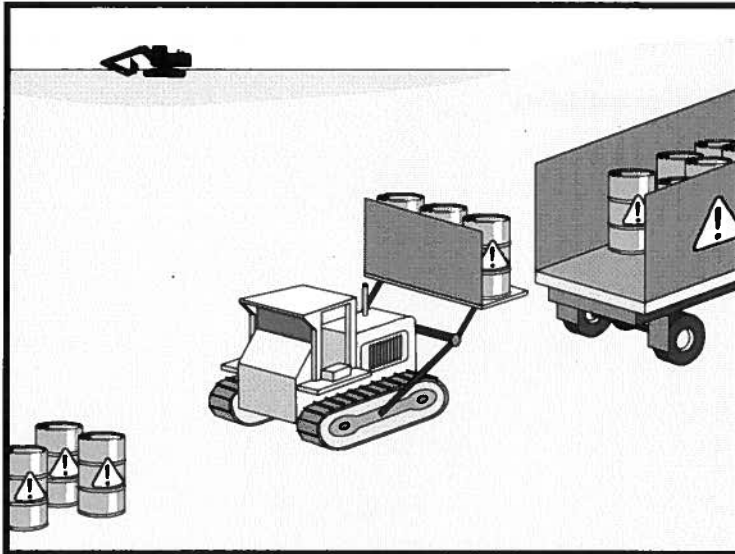

Standard Symbol

BMP Objectives

- Soil Stabilization
- Sediment Control
- Tracking Control
- Wind Erosion Control
- Non-Storm Water Management
- Materials and Waste Management

Definition and Purpose These are procedures and practices to minimize or eliminate the discharge of pollutants from construction site hazardous waste to the storm drain systems or to watercourses.

Appropriate Applications

- This best management practice (BMP) applies to all construction projects.
- Hazardous waste management practices are implemented on construction projects that generate waste from the use of:
 - Petroleum Products,
 - Asphalt Products,
 - Concrete Curing Compounds,
 - Pesticides,
 - Acids,
 - Paints,
 - Stains,
 - Solvents,
 - Wood Preservatives,
 - Roofing Tar, or
 - Any materials deemed a hazardous waste in California, Title 22 Division 4.5, or listed in 40 CFR Parts 110, 117, 261, or 302.

- Limitations**
- Nothing in this BMP relieves the Contractor from responsibility for compliance with federal, state, and local laws regarding storage, handling, transportation, and disposal of hazardous wastes.
 - This BMP does not cover aerially deposited lead (ADL) soils. For ADL soils refer to BMP WM-7, "Contaminated Soil Management," and the project special provisions.

Standards and Specifications

Education

- Educate employees and subcontractors on hazardous waste storage and disposal procedures.
- Educate employees and subcontractors on potential dangers to humans and the environment from hazardous wastes.
- Instruct employees and subcontractors on safety procedures for common construction site hazardous wastes.
- Instruct employees and subcontractors in identification of hazardous and solid waste.
- Hold regular meetings to discuss and reinforce hazardous waste management procedures (incorporate into regular safety meetings).
- The Contractor's Water Pollution Control Manager (WPCM) shall oversee and enforce proper hazardous waste management procedures and practices.
- Make sure that hazardous waste is collected, removed, and disposed of only at authorized disposal areas.

Storage Procedures

- Wastes shall be stored in sealed containers constructed of a suitable material and shall be labeled as required by Title 22 CCR, Division 4.5 and 49 CFR Parts 172,173, 178, and 179.
- All hazardous waste shall be stored, transported, and disposed as required in Title 22 CCR, Division 4.5 and 49 CFR 261-263.
- Waste containers shall be stored in temporary containment facilities that shall comply with the following requirements:
 - Temporary containment facility shall provide for a spill containment volume able to contain precipitation from a 24-hour, 25 year storm event, plus the greater of 10% of the aggregate volume of all containers or 100% of the capacity of the largest tank within its boundary, whichever is greater.

- Temporary containment facility shall be impervious to the materials stored there for a minimum contact time of 72 hours.
 - Temporary containment facilities shall be maintained free of accumulated rainwater and spills. In the event of spills or leaks accumulated rainwater and spills shall be placed into drums after each rainfall. These liquids shall be handled as a hazardous waste unless testing determines them to be non-hazardous. Non-hazardous liquids shall be sent to an approved disposal site.
 - Sufficient separation shall be provided between stored containers to allow for spill cleanup and emergency response access.
 - Incompatible materials, such as chlorine and ammonia, shall not be stored in the same temporary containment facility.
 - Throughout the rainy season, temporary containment facilities shall be covered during non-working days, and prior to rain events. Covered facilities may include use of plastic tarps for small facilities or constructed roofs with overhangs. A storage facility having a solid cover and sides is preferred to a temporary tarp. Storage facilities shall be equipped with adequate ventilation.
- Drums shall not be overfilled and wastes shall not be mixed.
 - Unless watertight, containers of dry waste shall be stored on pallets.
 - Paint brushes and equipment for water and oil based paints shall be cleaned within a contained area and shall not be allowed to contaminate site soils, watercourses or drainage systems. Waste paints, thinners, solvents, residues, and sludges that cannot be recycled or reused shall be disposed of as hazardous waste. When thoroughly dry, latex paint and paint cans, used brushes, rags, absorbent materials, and drop cloths shall be disposed of as solid waste.
 - Ensure that adequate hazardous waste storage volume is available.
 - Ensure that hazardous waste collection containers are conveniently located.
 - Designate hazardous waste storage areas on site away from storm drains or watercourses and away from moving vehicles and equipment to prevent accidental spills.
 - Minimize production or generation of hazardous materials and hazardous waste on the job site.
 - Use containment berms in fueling and maintenance areas and where the potential for spills is high.

- Segregate potentially hazardous waste from non-hazardous construction site debris.
- Keep liquid or semi-liquid hazardous waste in appropriate containers (closed drums or similar) and under cover.
- Clearly label all hazardous waste containers with the waste being stored and the date of accumulation.
- Place hazardous waste containers in secondary containment.
- Do not allow potentially hazardous waste materials to accumulate on the ground.
- Do not mix wastes.

Disposal Procedures

- Waste shall be disposed of outside the highway right-of-way within 90 days of being generated, or as directed by the Resident Engineer (RE). In no case shall hazardous waste storage exceed requirements in Title 22 CCR, Section 66262.34.
- Waste shall be disposed of by a licensed hazardous waste transporter at an authorized and licensed disposal facility or recycling facility utilizing properly completed Uniform Hazardous Waste Manifest forms.
- A Department of Health Services (DHS) certified laboratory shall sample waste and classify it to determine the appropriate disposal facility.
- Make sure that toxic liquid wastes (e.g., used oils, solvents, and paints) and chemicals (e.g., acids, pesticides, additives, curing compounds) are not disposed of in dumpsters designated for solid waste construction debris.
- Properly dispose of rainwater in secondary containment that may have mixed with hazardous waste.
- Recycle any useful material such as used oil or water-based paint when practical.
- Attention is directed to "Hazardous Material", "Contaminated Material", and "Aerially Deposited Lead" of the contract documents regarding the handling and disposal of hazardous materials.

Maintenance and Inspection

- A foreman and/or construction supervisor shall monitor on-site hazardous waste storage and disposal procedures.
- Waste storage areas shall be kept clean, well organized, and equipped with ample clean-up supplies as appropriate for the materials being stored.
- Storage areas shall be inspected in conformance with the provisions in the contract documents.
- Perimeter controls, containment structures, covers, and liners shall be repaired or replaced as needed to maintain proper function.
- Hazardous spills shall be cleaned up and reported in conformance with the applicable Material Safety Data Sheet (MSDS) and the instructions posted at the project site.
- The National Response Center, at (800) 424-8802, shall be notified of spills of Federal reportable quantities in conformance with the requirements in 40 CFR parts 110, 117, and 302.
- Copy of the hazardous waste manifests shall be provided to the RE.

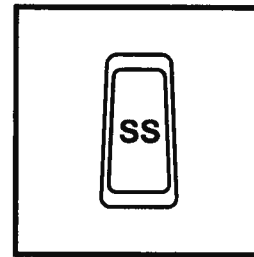
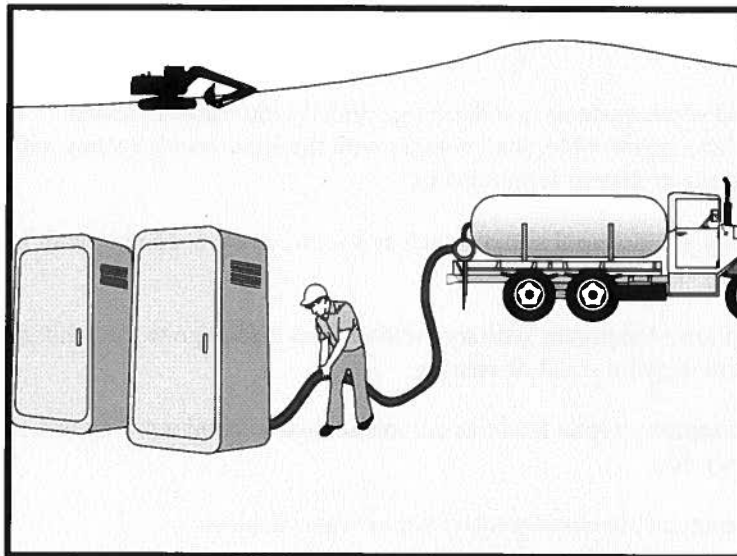

Standard Symbol

BMP Objectives

- Soil Stabilization
- Sediment Control
- Tracking Control
- Wind Erosion Control
- Non-Storm Water Management
- Materials and Waste Management

- Definition and Purpose** Procedures and practices to minimize or eliminate the discharge of construction site sanitary/septic waste materials to the storm drain system or to watercourses.
- Appropriate Applications** Sanitary/septic waste management practices are implemented on all construction sites that use temporary or portable sanitary/septic waste systems.
- Limitations** ■ None identified.
- Standards and Specifications**
- Education**
- Educate employees, subcontractors, and suppliers on sanitary/septic waste storage and disposal procedures.
 - Educate employees, subcontractors, and suppliers of potential dangers to humans and the environment from sanitary/septic wastes.
 - Instruct employees, subcontractors, and suppliers in identification of sanitary/septic waste.
 - Hold regular meetings to discuss and reinforce disposal procedures (incorporate into regular safety meetings).
 - Establish a continuing education program to indoctrinate new employees.
- Storage and Disposal Procedures**
- Temporary sanitary facilities shall be located away from drainage facilities, watercourses, and from traffic circulation. When subjected to high winds or risk.

Sanitary/Septic Waste Management

WM-9

- Wastewater shall not be discharged or buried within the highway right-of-way.
 - Sanitary and septic systems that discharge directly into sanitary sewer systems, where permissible, shall comply with the local health agency, city, county, and sewer district requirements.
 - If using an on site disposal system, such as a septic system, comply with local health agency requirements.
 - Properly connect temporary sanitary facilities that discharge to the sanitary sewer system to avoid illicit discharges.
 - Ensure that sanitary/septic facilities are maintained in good working order by a licensed service.
 - Use only reputable, licensed sanitary/septic waste haulers.
- Maintenance and Inspection**
- The Contractor's Water Pollution Control Manager (WPCM) shall monitor onsite sanitary/septic waste storage and disposal procedures at least weekly.



BioSorb



Oil Absorbing Polymers

Our Bio-Sorb oil absorbing polymers are uniquely formulated to clean up...

- Spills
- Chemical Spills
- Fuel Oil Spills
- Diesel Oil Spills

Control and absorb oil and hydrocarbons on any surface - including water

- Control oil spills and slicks in harbor and dock areas
- Control oil contamination in municipal run-off
- Remove oil contamination from plant process water
- Clean-up fuel spills on highways
- Absorb hydrocarbon vapors and fumes

	TIME (seconds)	% Uptake	C
0	0.00	0.0000	
1	30.0	104.00	
2	60.0	107.00	
3	120	128.00	
4	180	155.00	
5	240	164.00	
6	300	188.00	

How Are Bio-Sorb Oil Absorbing Polymers Unique?

Bio-Sorb oil absorbing polymers function by first attracting hydrocarbons to the surface of the polymer to adsorb the liquid, followed immediately by internally absorbing the media into its structure. Bio-Sorb oil absorbing polymers will not absorb water, which lends the material a unique usefulness for separating and collecting hydrocarbons from water mixtures. Most notably, the polymer can commonly absorb from 20% to 200% or more of its own weight of chemical or petroleum derived liquids. Furthermore, because of the unique absorption characteristic of the material, Bio-Sorb becomes dry to the touch shortly after sorption.

BioSorb Oil Absorbing Polymers are Useful for the Following Applications:

Potential applications for Bio-Sorb hydrocarbon absorbing materials are numerous as a result of their unique nature. One can imagine the numerous applications for commercial, industrial, defense and ecological markets.

- Stormwater Filters
- Concentrate Carrier Material for Liquid Additives
- Removing Oil or Chemicals from Contaminated Water Streams or Water/Soil Slurries
- Industrial Work Area Collection Mats
- Spill Containment and Collection
- Odor Barrier/Collector for Flavor Oils and Fragrances
- Collection of Volatile Organic Compounds (VOC's)
- Many Others

Hydrocarbon Uptake Study

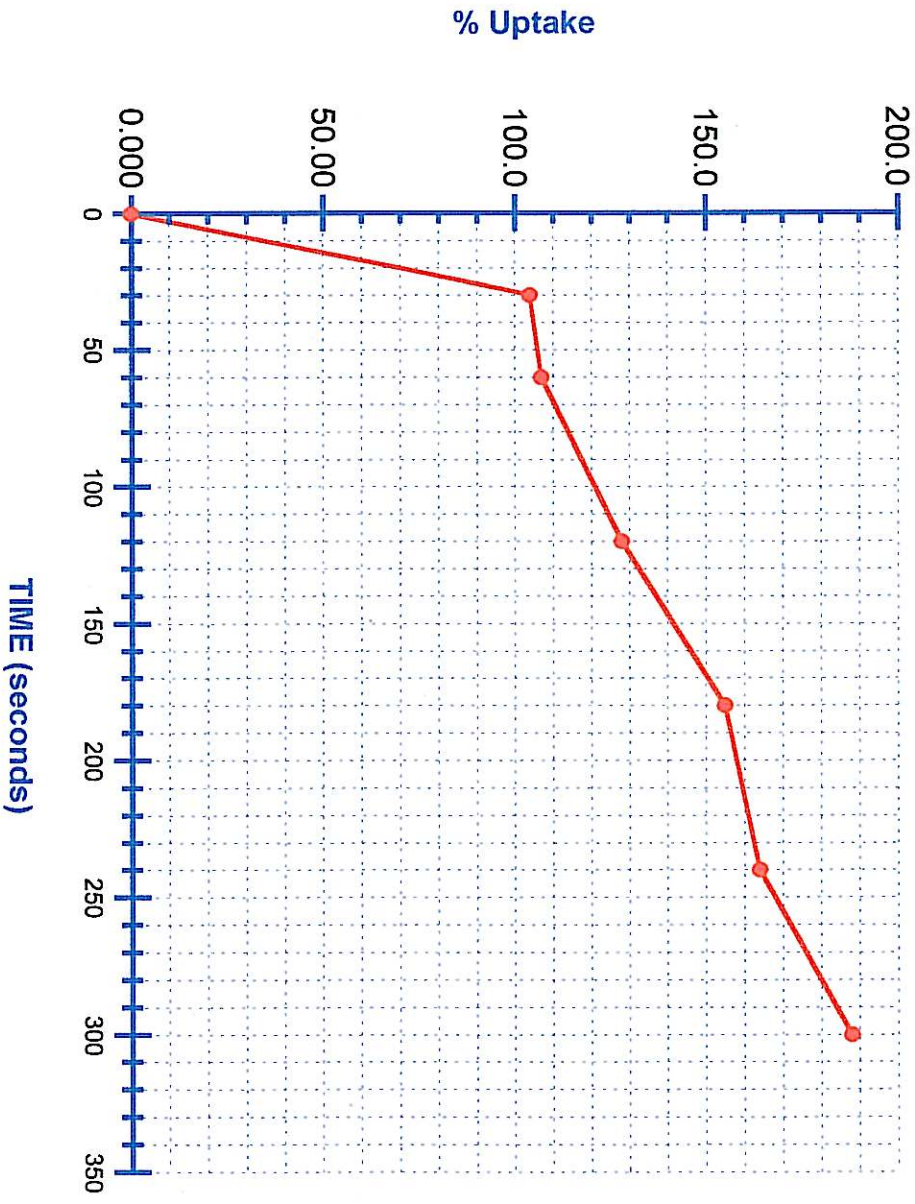

	TIME (seconds)	% Uptake	C
0	0.00	0.0000	
1	30.0	104.00	
2	60.0	107.00	
3	120	128.00	
4	180	155.00	
5	240	164.00	
6	300	188.00	

SPECIFICATIONS

BioSorb Hydrocarbon Booms

I. Specifications

Coverage: When properly installed BioSorb Hydrocarbon Booms provide sufficient contact time, at rated flows, of passing contaminate water. The BioSorb material will capture and retain all hydrocarbons that are absorbed into its physical structure. The BioSorb material is made of a proprietary polymer based beads. The material is usually contained within booms or pouches. The booms and pouches are made of 100% polyester netted fabric with sieve openings of 1mm, open area ratio is approximately 67%. These booms and pouches can be used in an array of different treatment devices, including but not limited to flume filters, trench drain filters, downspout filters, catch basin inserts, water polishing units, and hydrodynamic separators.

Non-Corrosive Materials: Both the BioSorb material and the boom and pouch netting are non-corrosive materials.

Durability: The BioSorb and netting material have been chosen for their proven durability, with an expected life of 5 plus years. The BioSorb and netting are of sufficient strength to support water, sediment, and debris loads when the media is at maximum absorption capacity; with no slippage, breaking, or tearing. The BioSorb has been tested through rigorous flow and loading conditions.

Oil Absorbent Media: The BioSorb has been proven to absorb up to 180% of its weight within 300 second contact time. At this absorption percent the physical increase in the size of the BioSorb granules is not more than 50%. This minimal increase in physical size in relation to the high absorption capacity is due to the BioSorb material being highly porous with large amounts of void areas within its structure. The flow through the media boom, assuming 50% blockage is to be greater than the physical flow through the filter device. This information can be obtained from a Bio Clean representative, if the BioSorb Boom is used within a Bio Clean Filter System.

Pollutant Removal Efficiency: The BioSorb is designed to capture high levels of Hydrocarbons including but not limited to oils & grease, gasoline, diesel, and PAHs. The granule nature of the material, with approximately 2000mm sized granules also has the physical ability to block and filter trash and litter, grass and foliage, and sediments.

Replacement: Removal and replacement of the booms containing the absorbent media is simple. Remove boom from filtration system. Replace with new boom of equal size.

II. Installation

Installation: The BioSorb Boom will be securely installed in the filter device, with contact surfaces sufficiently joined together so that no filter bypass can occur at low flow.

Installation Notes:

1. Bio Clean Environmental Services, Inc. BioSorb Boom shall be installed pursuant to the manufacturer's recommendations and the details on this sheet.
2. BioSorb Boom shall provide coverage of the incoming stormwater at the specified flow rate, based upon application and the device in which the boom is used in.
3. The BioSorb Boom is installed by removing the old boom and replacing it with a new boom.

III. Maintenance

Maintenance: The BioSorb boom is made to be used for a period that is determined by the amount of hydrocarbon loading present in each installation. The Boom is easily removable from most filter devices. At each cleaning, new hydrocarbon booms should be installed by placing in the filter if deemed necessary by service crews.

Maintenance Notes:

1. Bio Clean Environmental Services Inc. recommends cleaning and debris removal maintenance a minimum of four times per year, and replacement of BioSorb Booms a minimum of twice per year.
2. Following maintenance and/or inspection, the maintenance operator shall prepare a maintenance/inspection record. The record shall include any maintenance activities performed, amount and description of debris collected, and condition of filter.
3. The owner shall retain the maintenance/inspection record for a minimum of five years from the date of maintenance. These records shall be made available to the governing municipality for inspection upon request at any time.
4. For maintenance and cleaning remove old boom and replace with new boom. Where possible the maintenance should be performed from the ground surface. Note: entry into an underground stormwater vault such as an inlet vault requires certification in confined space training.
5. Remove all trash, debris, organics, and sediments collected by the filter prior to removal and replacement of the BioSorb Boom.
6. Evaluation of the BioSorb Boom shall be performed at each cleaning. If the boom is filled with hydrocarbons and oils it should be replaced. The color of the boom material is the best indication of the amount of hydrocarbons present in the BioSorb material. The darker the color the more impacted the BioSorb material.
7. Transport all debris, trash, organics and sediments to approved facility for disposal in accordance with local and state requirements.
8. The BioSorb boom may be classified as hazardous material and will have to be picked up and disposed of as hazardous waste. Hazardous material can only be handled by a certified hazardous waste trained person (minimum 24-hour hazwoper).

Appendix VII

BMP Information

Final Landscaping and Site Stabilization BMPs

This section is not applicable to Encina Substation Upgrade because there is no landscaping or site stabilization.

Post-Construction Long-Term Maintenance Plan

Encina Substation Upgrade

- The site will not have any permanent BMPs to maintain after construction.

Appendix VIII

REAPS

Rain Event Action Plan

Not Applicable

The Encina Substation Upgrade project is a Risk Level 1, therefore a REAP is not required.

Appendix IX

Site Inspection

Appendix X

Construction Site Monitoring Program (CSMP)

APPENDIX X CONSTRUCTION SITE MONITORING PROGRAM (CSMP)

1 OVERVIEW

A site specific CSMP is required under the CGP. The purpose of the CSMP is to include all monitoring procedures and instructions, location maps, forms, and checklists. It is the responsibility of the QSP to implement the CSMP. The QSD shall revise the CSMP as necessary to reflect project revisions and whenever there is a change of ownership for all or any portion of the construction site prior to completion or final stabilization.

2 VISUAL MONITORING (INSPECTION) REQUIREMENTS

The visual observations (inspections) described in this Construction Site Monitoring Plan (CSMP) are specific to sampling events and are not equivalent to the Site Inspections described in Section 4.7 of this SWPPP.

A. Visual Monitoring (Inspection) for Qualifying Rain Events (QREs).

A QRE is defined as any precipitation of ½ inch or more at the time of discharge. A blank Visual Observation (inspection) for a Qualifying Rain Event form is provided in Appendix I. The QSP must complete these forms during the visual observation and insert a completed copy in Appendix XI.B of this SWPPP. See Section 6.0 for record-keeping requirements.

Requirements for Risk Level 1:

- Visually observe (inspect) the discharge of stored or contained storm water that is derived from and discharged subsequent to a QRE. Stored or contained storm water that will likely discharge after operating hours due to anticipated precipitation shall be observed prior to the discharge during operating hours.
- Observations shall be done only during business hours. Business hours are anytime work is being conducted on the site.
- Record the time, date and rain gauge reading of all QREs.
- **Before a QRE (i.e., within 2 business days (48 hours)):**
 - **Storm Water:**
 - Observe all storm water drainage areas for:
 - Spills, leaks or uncontrolled pollutant sources and implement any needed corrective actions;

- The presence or absence of:
 - Floating and suspended materials;
 - A sheen on the surface;
 - Discolorations;
 - Turbidity;
 - Odors; and
 - Sources of any observed pollutants.
- **BMPs:**
 - Observe all BMPs for proper implementation in accordance with the SWPPP and implement appropriate corrective actions;
 - Observe any storm water storage and containment areas:
 - For leaks and to ensure maintenance of adequate freeboard;
 - The presence or absence of:
 - Floating and suspended materials;
 - A sheen on the surface;
 - Discolorations;
 - Turbidity;
 - Odors; and
 - Sources of any observed pollutants.
- **After** a QRE (Within 2 business days):
 - **BMPs:**
 - Observe whether BMPs were adequately designed, implemented, and effective; and
 - Identify additional BMPs and revise the SWPPP accordingly.

B. Visual Monitoring (Inspection) for Non-Storm Water Discharges

A blank form is provided in Appendix XI.A. The QSP must complete these forms during the visual observation and insert a completed copy in Appendix XI.B.

Requirements for Risk Level 1:

Visually observe (inspect) each drainage area for:

- The presence of (or indications of prior) unauthorized and authorized non-storm water discharges; and
- Their sources.

Shall conduct one visual observation (inspection) quarterly in each of the following periods:

- January- March;
- April-June;
- July-September; and
- October-December.

Visual observation (inspections) are only required during daylight hours (sunrise to sunset).

Shall ensure that visual observations (inspections) document the:

- Presence or evidence of any non-stormwater discharge (authorized or unauthorized);
- Pollutant characteristics (floating and suspended material, sheen, discoloration, turbidity, odor, etc.); and
- Source of the pollutants.

Shall maintain on-site records indicating the response taken to:

- Eliminate unauthorized non-storm water discharges; and
- Reduce or prevent pollutants from contacting non-storm water discharges.

- See Section 6.0 for additional record-keeping requirements.

2.1 Exemptions for Visual Observation and Sample Collection

Visual observations (inspections) and sample collection are not required under the following conditions:

- During dangerous weather conditions such as flooding and electrical storms.
- Outside of scheduled site business hours.

If one of these conditions occurs, document why the sampling or observations did not occur in the SWPPP and include the information in the Annual Report. A blank Form has been provided in Appendix I Attachment I.A. Keep a copy of the completed form in Attachment XI.B.

3 NON-VISIBLE POLLUTANT MONITORING REQUIREMENTS

Requirements for Risk Level 1:

- Collect one or more samples during any breach, malfunction, leakage, or spill observed during a visual inspection which could result in the discharge of pollutants to surface waters that would not be visually detectable in storm water.
- Ensure that water samples are large enough to characterize the site conditions.
- Collect samples at all discharge locations that can be safely accessed.

-
- Collect samples during the first two hours of discharge from rain events that occur during business hours and which generate runoff.
 - Analyze samples for all non-visible pollutant parameters – parameters indicating the presence of pollutants identified in the pollutant source assessment located in Section 3.1 below.
 - Collect a sample of storm water that has not come in contact with the disturbed soil or the materials stored or used on-site (uncontaminated sample) for comparison with the discharge sample.
 - Compare the uncontaminated sample to the samples of discharge using field analysis or through laboratory analysis.
 - Shall keep all field /or analytical data in the SWPPP document. Sampling Event Worksheet (Blank Form in Appendix XI.A / Completed Form in Appendix XI.D)

1. Pollutant Source Assessment

a. Historical Pollutants

Prior to commencement of construction at this project, the site was an existing substation.

No existing pollutants were found to be on site. Therefore, no known pollutants will be sampled for.

b. Potential pollutant sources

A list of potential pollutants is located in Appendix V. The list of potential pollutants generated includes all non-visible pollutants that are known or should be known to occur on the construction site.

Based on the sources of pollutants identified above, the following indicator parameters will be analyzed to determine if pollutants are anticipated to be conveyed from the site by storm water:

- Sediment
- Oil and Grease

4 STORM WATER DISCHARGE WATER QUALITY SAMPLING LOCATIONS

Sample only during any breach, malfunction, leakage, or spill observed during a visual inspection which could result in the discharge of pollutants to surface waters that would not be visually detectable in storm water.

Samples shall be collected at all discharge locations that can be safely accessed.

A. Effluent Sampling Locations:

To determine the effluent sampling locations, the following procedures must be conducted:

- Review a Drainage Map or any other exhibit that provide drainage patterns.
- Conduct a visual observation to determine and evaluate the following with respect to discharge locations:
 - Drainage areas
 - Run-on (control) from surrounding areas and if there is reason to believe run-on may contribute to an exceedance of NALs or NELs.
 - Location of non-storm water and/or authorized non-storm water discharges

This section identifies storm water sampling locations for effluent discharges. The purpose of sampling storm water discharges is to characterize discharges associated with construction activity from the entire project disturbed area.

Sampling locations for effluent samples at all discharge points where storm water is discharged off-site include the following:

There are 3 sampling locations for site runoff from the Encina Substation. There is 2 samples to be monitored as the control sample location. The sampling locations are described below.

The monitoring locations are shown on the Site Map in Appendix III. The sample locations have been identified for the site based on the drainage map for final build out conditions for the site. During the interim condition, the QSP will be responsible to identify the locations where storm water runoff exits the site, and identify the locations on the exhibit as site runoff monitoring locations.

5 STORM WATER SAMPLE COLLECTION AND HANDLING INSTRUCTIONS

Should there be a breach, leak or spillage that requires sampling, as discussed in Section 3, ensure that water samples are large enough to characterize the site conditions. A sample kit should be available on site in case of a need to sample. The sample kit should include:

- Ice chest
- Blue ice
- Rubber Gloves -3 to 4 pair
- Sample Bottles (provided by laboratory)
- Sharpie
- Chain of Custody Form
- Scoop

Sample bottles should be:

- Filled to top
- Do not pour between containers
- Label all bottles before collecting sample – use sharpie
- Store chilled (cooler or refrigerator)
- Secure cap
- Keep upright

Field Analysis

Analyses for pH and turbidity may be performed in the field using field meters. Field meters will be calibrated, maintained, and operated by trained staff according to the manufacturer's specifications, and calibration records will be stored in Appendix XI.D.

Laboratory Analysis

An analytical laboratory(ies) for sample analyses is identified in Appendix XI.D of this CSMP.

The laboratory will provide properly cleaned and preserved (if applicable) sampling containers (bottles) for the samples, and labels on the sample bottles. The sample bottle labels will identify the analysis to be performed and any preservative contained in the bottles, and provide room for recording the sample location and time and date of collection. The laboratory will also provide chain-of-custody forms. Example Chain of Custody form is located in Appendix XI.E.

Ensure that the testing laboratories will receive samples the same day or within 48 hours of the physical sampling (unless otherwise required by the laboratory), and shall use only the sample containers provided by the laboratory to collect and store samples.

The LRP shall designate and train personnel to collect, maintain, and ship samples in accordance with the Surface Water Ambient Monitoring Program's (SWAMP) 2008 Quality Assurance Program Plan (QAPrP). See footnote 6 on page 15 of Attachment E of the CGP for additional information regarding SWAMP and QAPrP.

The following table provides information for constituents to be monitored for non-visible parameters.

Analyte	EPA Analytical Method Number	Minimum Sample Volume ³	Sampling Container	Preservative ⁴	Holding Time
Nitrate as Nitrogen	EPA 352.1 or 300.0 or SM 4110 B or SM4500-NO ⁵	25 mL	Polypropylene or glass	None	48 hours
Oil and Grease	EPA 1664 A	1 L	Amber glass	HCl or H ₂ SO ₄ to pH < 2	28 days

³Minimum sample volume recommended. Specific volume requirements will vary by laboratory and must be verified with the laboratory when bottles are ordered.

⁴Do not pre-rinse or overfill sample containers that contain preservative.

⁵All samples must be kept chilled to 4°C (keep samples on ice for delivery to analytical laboratory)

6 ANALYTICAL AND MONITORING METHODS

If the any upgrades of BMPs occur, the SWPPP will be revised accordingly by the QSD and a record of the upgrade will be kept in Appendix XI.B.

A. Effluent Sampling Methods:

Refer to the table in Section 5 above for test methods, detection limits, and reporting units.

This project is a Risk Level 1 project, therefore effluent monitoring is not applicable.

B. Non-Visible Pollutants

The Encina Substation Upgrade project is located in the Carlsbad Hydrologic Subarea of Hydrologic Unit basin number 904.00. The Water Quality Control Plan for the 9 Region ("Basin Plan") provides water quality objectives for some of the analytes that will be monitored. While these do not constitute a discharge standard or limit, these water quality objectives will be used as decision making benchmark standards. Where such standards are not available through the Basin Plan, benchmark standards set forth by other agencies will be used for decision making purposes.

The table below lists the benchmarks that will be used.

Benchmark Criteria for Decision Making					
Analyte		Benchmark Concentration		Reference	
Nitrate		0.68 mg/L		USEPA	
Oil and Grease		15 mg/L		USEPA*	

*United States Environmental Protection Agency Multi-Sector Industrial Permit

- **Bioassessment**

At the time this SWPPP was developed, the project was not greater than 30 acres is not a Risk Level 3 project and does not directly discharge into the receiving waters.

Since the project is not a Risk Level 3 project, no bioassessment monitoring is required.

7 RECORDS

Risk Level 1 dischargers shall retain records of all storm water monitoring information and copies of all reports (including Annual Reports) for a period of at least three years. Risk Level 1 dischargers shall retain all records on-site while construction is ongoing.

Appendix XI

CSMP Attachments



A Sempra Energy utility

CHAIN OF CUSTODY/SAMPLE SUBMITTAL FORM

ENVIRONMENTAL ANALYSIS LABORATORY

6555 NANCY RIDGE DRIVE, SUITE 300, SAN DIEGO, CA 92121-3221
(858) 503-5371 FAX: (858) 503-5398

LAB NO.

WORK ID.	CLIENT NAME	CLIENT CODE
SAMPLED BY (Print & Signature)	CLIENT'S PHONE	PROJECT CODE
CLIENT'S ADDRESS	NUMBER OF CONTAINERS	DATE DUE

SAMPLE ID	DATE	TIME	SAMPLE TYPE	SAMPLE CONTAINER	PRESERVATION	ANALYSIS NEEDED	TEST CODE(S)

COMMENTS

RELEASING	DATE	TIME	ACCEPTING	DATE	TIME
RELEASING	DATE	TIME	ACCEPTING	DATE	TIME

Appendix XII

Permit Registration Documents



State Water Resources Control Board
NOTICE OF INTENT
GENERAL PERMIT TO DISCHARGE STORM WATER
ASSOCIATED WITH CONSTRUCTION ACTIVITY
(WQ ORDER No. 2009-0009-DWQ)



WDID: 9 37C357876

Risk Level: Level1

Property Owner Information

Type: Private Business

Name: San Diego Gas & Electric

Contact Name: Amethyst Cruspero

Address: 8315 Century Park Ct CP21G

Title: Compliance Specialist

Address 2:

Phone #: 619-778-6029

City/State/Zip: San Diego CA 92123

Email: ACruspero@SempraUtilities.com

Contractor/Developer Information

Name: San Diego Gas & Electric

Contact Name: Amethyst Cruspero

Address: 8315 Century Park Ct CP21G

Title: Compliance Specialist

Address 2:

Phone #: 619-778-6029

City/State/Zip: San Diego CA 92123

Email: ACruspero@SempraUtilities.com

Construction Site Information

Site Name: Sunrise Powerlink Encina Substation

Contact Name: Amethyst Cruspero

Address: 4600 Carlsbad Blvd

Title: Compliance Specialist

City/State/Zip: Carlsbad CA 92008

Site Phone #: 619-778-6029

County: San Diego

Email: ACruspero@SempraUtilities.com

Latitude: 33.138333

Longitude: -117.333888

Total Size of Construction Area: 3.3

Construction Start: June 01, 2010

Total Area to be Disturbed: 3.3

Complete Grading:

Final Stabilization: March 01, 2012

Type of Construction: *Utility: Upgrade to existing substation

Receiving Water: Agua Hedionda lagoon Pacific Ocean

Qualified SWPPP Developer:

Certification #:

RWQCB Jurisdiction: Region 9 - San Diego

Phone: 858-467-2952

Email: r9_stormwater@waterboards.ca.gov

Certification

Name: Robert Jackson

Date: June 22, 2010

Title: General Manager



Patrick Lee
Vice President
Sunrise Powerlink Project

San Diego Gas & Electric
8330 Century Park Court, CP33A
San Diego, CA 92123-1530

Tel: 858.650.6101
Fax: 858.650.6106
Patrick.lee@semprautilities.com

TO: Distribution

DATE: June 24, 2010

FROM: Patrick Lee

A handwritten signature in cursive script that reads 'Patrick Lee'.

**SUBJECT: State Water Resources Control Board
Construction Storm Water General Permit (Order 2009-0009)
Authorized Signatories for
San Diego Gas & Electric's Sunrise Power Link Project**

I am a Legally Responsible Person pursuant to State Water Resources Control Board Order No. 2009-0009-DWQ (NPDES General Permit No. CAS000002 – General Permit for Storm Water Discharges Associated with Construction and Land Disturbance Activities or “General Permit”). This letter is to acknowledge the persons listed below are authorized as Approved Signatories under this permit:

- ◆ Robert Jackson
- ◆ Jonathan Woldemariam

A copy of this authorization shall be retained with each Storm Water Pollution Prevention Plan prepared pursuant to this authorization.

Distribution: Robert Jackson; Jonathan Woldemariam, Alan Colton, Don Haines, Linda Collins, Amethyst Cruspero, Fred Jacobsen



Linda S. Adams
 Secretary for
 Environmental Protection

State Water Resources Control Board

Division of Water Quality

1001 I Street Sacramento, California 95814 (866) 563 3107
 Mailing Address: P.O. Box 1977 Sacramento, California 95812-1977
 FAX (916) 341-5543 Internet Address: <http://www.waterboards.ca.gov>
 Email Address: stormwater@waterboards.ca.gov



Arnold Schwarzenegger
 Governor

Approved Date: 04/13/2010

Linda Collins
 San Diego Gas & Electric
 8315 Century Park Ct CP21G
 San Diego CA 92123

RECEIPT OF YOUR NOTICE OF INTENT (NOI)

The State Water Resources Control Board (State Water Board) has received and processed your NOI to comply with the terms of the General Permit to Discharge Storm Water Associated with Construction Activity. Accordingly, you are required to comply with the permit requirements.

The Waste Discharger Identification (WDID) number is: **9 37C357876**. Please use this number in any future communication regarding this permit.

OWNER:	SITE DESCRIPTION
DEVELOPER:	San Diego Gas & Electric
SITE INFORMATION:	San Diego Gas & Electric
	Sunrise Powerlink Encina Substation
	4600 Carlsbad Blvd
	Carlsbad
TOTAL DISTURBED ACRES:	3.3
START DATE:	06/01/2010
COMPLETION DATE:	03/01/2012
COUNTY:	San Diego

When the Owner changes , a new NOI, site map, and fee must be submitted by the new Owner. As the previous owner, you are required to submit a Notice of Termination (NOT) to the local Regional Water Board stating you no longer own or operate the Site and coverage under the General Permit is not required. Unless notified, you will continue and are responsible to pay the annual fee invoiced each April.

If you have any questions regarding permit requirements, please contact your Regional Water Board at 858-467-2952 . Please visit the storm water web site at http://www.waterboards.ca.gov/water_issues/programs/stormwater/ to obtain an NOT and other storm water related information and forms.

Sincerely,

Storm Water Section
 Division of Water Quality



U.S. ENVIRONMENTAL PROTECTION AGENCY

National Pollutant Discharge Elimination System (NPDES)

[Recent Additions](#) | [Contact Us](#) | [Print Version](#) Search NPDES:

[EPA Home](#) > [OW Home](#) > [OWM Home](#) > [NPDES Home](#) >

Basic Information

NPDES Topics

Alphabetical Index

Glossary

About NPDES

eNOI

Municipal MS4s

Construction Activities

Industrial Activities

Road-Related MS4s

Menu of BMPs

Green Infrastructure

Urban BMP Tool

Stormwater Home

Rainfall Erosivity Factor Calculator for Small Construction Sites

Facility Information

Facility Name: Encina Substation
 Start Date: 10/15/2010
 End Date: 03/01/2012
 Latitude: 33.1383
 Longitude: -117.3338

Erosivity Index Calculator Results

AN EROSIVITY INDEX VALUE OF **65.34** HAS BEEN DETERMINED FOR THE CONSTRUCTION PERIOD OF **10/15/2010 - 03/01/2012**.

A rainfall erosivity factor of 5.0 or greater has been calculated for your site and period of construction. **You do not qualify for a waiver from NPDES permitting requirements.**



Stormwater Information
Recent Additions
FAQs
Publications
Regulations
Training & Meetings
Links
Contacts



The documents on this site are best viewed with Acrobat 8.0

[Office of Water](#) | [Office of Wastewater Management](#) | [Disclaimer](#) | [Search EPA](#)

[EPA Home](#) | [Privacy and Security Notice](#) | [Contact Us](#)

Last updated on August 07, 2009 3:37 PM

URL: http://cfpub.epa.gov/npdes/stormwater/lew/erosivity_index_result.cfm

	A	B	C
1	Sediment Risk Factor Worksheet		Entry
2	A) R Factor		
3	Analyses of data indicated that when factors other than rainfall are held constant, soil loss is directly proportional to a rainfall factor composed of total storm kinetic energy (E) times the maximum 30-min intensity (I30) (Wischmeier and Smith, 1958). The numerical value of R is the average annual sum of EI30 for storm events during a rainfall record of at least 22 years. "Isoerodent" maps were developed based on R values calculated for more than 1000 locations in the Western U.S. Refer to the link below to determine the R factor for the project site.		
4	http://cfpub.epa.gov/npdes/stormwater/LEW/lewCalculator.cfm		
5	R Factor Value		65.34
6	B) K Factor (weighted average, by area, for all site soils)		
7	The soil-erodibility factor K represents: (1) susceptibility of soil or surface material to erosion, (2) transportability of the sediment, and (3) the amount and rate of runoff given a particular rainfall input, as measured under a standard condition. Fine-textured soils that are high in clay have low K values (about 0.05 to 0.15) because the particles are resistant to detachment. Coarse-textured soils, such as sandy soils, also have low K values (about 0.05 to 0.2) because of high infiltration resulting in low runoff even though these particles are easily detached. Medium-textured soils, such as a silt loam, have moderate K values (about 0.25 to 0.45) because they are moderately susceptible to particle detachment and they produce runoff at moderate rates. Soils having a high silt content are especially susceptible to erosion and have high K values, which can exceed 0.45 and can be as large as 0.65. Silt-size particles are easily detached and tend to crust, producing high rates and large volumes of runoff. Use Site-specific data must be submitted.		
8	Site-specific K factor guidance		
9	K Factor Value		0.2
10	C) LS Factor (weighted average, by area, for all slopes)		
11	The effect of topography on erosion is accounted for by the LS factor, which combines the effects of a hillslope-length factor, L, and a hillslope-gradient factor, S. Generally speaking, as hillslope length and/or hillslope gradient increase, soil loss increases. As hillslope length increases, total soil loss and soil loss per unit area increase due to the progressive accumulation of runoff in the downslope direction. As the hillslope gradient increases, the velocity and erosivity of runoff increases. Use the LS table located in separate tab of this spreadsheet to determine LS factors. Estimate the weighted LS for the site prior to construction.		
12	LS Table		
13	LS Factor Value		0.43
14			
15	Watershed Erosion Estimate (=RxKxLS) in tons/acre		5.61924
16	Site Sediment Risk Factor		Low
17	Low Sediment Risk: < 15 tons/acre		
18	Medium Sediment Risk: >=15 and <75 tons/acre		
19	High Sediment Risk: >= 75 tons/acre		
20			

Receiving Water (RW) Risk Factor Worksheet	Entry	Score
A. Watershed Characteristics	yes/no	
A.1. Does the disturbed area discharge (either directly or indirectly) to a 303(d)-listed waterbody impaired by sediment (For help with impaired waterbodies please visit the link below) or has a USEPA approved TMDL implementation plan for sediment ?:	no	Low
http://www.waterboards.ca.gov/water_issues/programs/tmdl/integrated2010.shtml		
OR		
A.2. Does the disturbed area discharge to a waterbody with designated beneficial uses of SPAWN & COLD & MIGRATORY? (For help please review the appropriate Regional Board Basin Plan)		
http://www.waterboards.ca.gov/waterboards_map.shtml		
Region 1 Basin Plan Region 2 Basin Plan Region 3 Basin Plan Region 4 Basin Plan Region 5 Basin Plan Region 6 Basin Plan Region 7 Basin Plan Region 8 Basin Plan Region 9 Basin Plan		

Combined Risk Level Matrix

		<u>Sediment Risk</u>		
		Low	Medium	High
<u>Receiving Water Risk</u>	Low	Level 1	Level 2	
	High	Level 2		Level 3

Project Sediment Risk: **Low**

Project RW Risk: **Low**

Project Combined Risk: **Level 1**

ORIGINAL - MAKE COPIES

**CERTIFICATION FORM
(Store Completed Forms in Appendix XII)**

Project Name Encina Substation
WDID Number 9 37C357876

This certification is for (check appropriate box):

The QSD will complete this box and, once signed by the approved signatory, insert the signed certification form in the appropriate Appendix.

- Amendment to SWPPP (Appendix XVI)
- PRDs (Appendix XII)
- NOT (Appendix XII)
- Other _____

Any person signing documents under Section IV.1 of the CGP shall make the following certification:

"I certify under penalty of law that this document and all attachments were prepared under my direction or supervision in accordance with a system designed to assure that qualified personnel properly gather and evaluate the information submitted. Based on my inquiry of the person or persons who manage the system or those persons directly responsible for gathering the information, to the best of my knowledge and belief, the information submitted is, true, accurate, and complete. I am aware that there are significant penalties for submitting false information, including the possibility of fine and imprisonment for knowing violations."

Robert C. Jackson
Name of LRP *

Gen Mgr + Dir. Constrn Engrg
Title

San Diego Gas + Electric
Company

(858) 654-6451
Telephone Number

Signature

6-16-2010
Date

*or approved signatory.

Appendix XIII

Responsible Parties

Appendix XIII List of Responsible Parties

PROJECT: Encina Substation Upgrades | **WDID NUMBER:** 9 37C357876

<input type="checkbox"/> LEGALLY RESPONSIBLE PARTIES (LRP)				<input checked="" type="checkbox"/> THE LRP's APPROVED SIGNATORY			
AREA OF RESPONSIBILITY:		Construction and Engineering Sunrise Powerlink Project					
NAME	Robert C. Jackson				TITLE:	General Manager & Director	
COMPANY NAME:		SDG&E					
ADDRESS		8315 Century Park Court					
CITY	San Diego			STATE	CA	ZIP	92123
TELEPHONE		858-654-6451					
EMERGENCY TELEPHONE		619-778-6029					
FAX	858-637-3731						
E-MAIL	RCJackson@semprautilities.com						

QUALIFIED SWPPP DEVELOPER (QSD)-RESPONSIBLE FOR PREPARING THE SWPPP:							
NAME	Sharon Humphreys, PE				TITLE:	Senior Project Manager	
COMPANY NAME:		Bureau Veritas					
ADDRESS		11590 West Bernardo Drive, Suite 100					
CITY	San Diego			STATE	CA	ZIP	92127
TELEPHONE		858-207-5091					
EMERGENCY TELEPHONE		858-776-9402					
FAX	858-451-2846						
E-MAIL	Sharon.humphreys@us.bureauveritas.com						

ADDITIONAL QSD:							
AREA OF RESPONSIBILITY:		Preparation of the SWPPP					
NAME	Tracy Beach, PE				TITLE:	Civil Engineer	
COMPANY NAME:		Bureau Veritas					
ADDRESS		11590 West Bernardo Drive, Suite 100					
CITY	San Diego			STATE	CA	ZIP	92127
TELEPHONE		858-207-5091					
EMERGENCY TELEPHONE		858-663-1887					
FAX	858-451-2846						
E-MAIL	Tracy.beach@us.bureauveritas.com						
START DATE				END DATE			

QUALIFIED SWPPP PRACTITIONER (QSP):			
AREA OF RESPONSIBILITY:			
NAME	Alex Greene	TITLE:	Senior Engineering Geologist
COMPANY NAME:	Geosyntec Consultants		
ADDRESS	10875 Rancho Bernardo Road, Suite 200		
CITY	San Diego	STATE	CA ZIP 92127
TELEPHONE	858-716-2911		
EMERGENCY TELEPHONE	619-997-6095		
FAX	858-674-6586		
E-MAIL	AGreene@Geosyntec.com		
START DATE	9/7/2010	END DATE	6/15/2013

ADDITIONAL QSP:			
AREA OF RESPONSIBILITY: Daily Inspections			
NAME	Nick Jordan	TITLE:	SWPPP Coordinator
COMPANY NAME:	Par Electric		
ADDRESS	1010 Tavern Road		
CITY	Alpine	STATE	CA ZIP 91901
TELEPHONE	816-949-1000		
EMERGENCY TELEPHONE	619-772-0508		
FAX	619-445-4009		
E-MAIL	njordan@parelectric.com		
START DATE	7/25/2011	END DATE	6/15/2013

SPILL RESPONSE PERSONNEL			
NAME		TITLE:	
ADDRESS			
CITY		STATE	ZIP
TELEPHONE			
EMERGENCY TELEPHONE			
FAX			
E-MAIL			
START DATE		END DATE	

SPILL RESPONSE PERSONNEL			
NAME		TITLE:	
ADDRESS			
CITY		STATE	ZIP
TELEPHONE			
EMERGENCY TELEPHONE			
FAX			
E-MAIL			
START DATE		END DATE	

SPILL RESPONSE PERSONNEL			
NAME		TITLE:	
ADDRESS			
CITY		STATE	ZIP
TELEPHONE			
EMERGENCY TELEPHONE			
FAX			
E-MAIL			
START DATE		END DATE	

SPILL RESPONSE PERSONNEL			
NAME		TITLE:	
ADDRESS			
CITY		STATE	ZIP
TELEPHONE			
EMERGENCY TELEPHONE			
FAX			
E-MAIL			
START DATE		END DATE	

STORM WATER SAMPLING AGENT:			
CONTACT PERSON		TITLE:	
ADDRESS			
CITY		STATE	ZIP
TELEPHONE			
EMERGENCY TELEPHONE			
FAX			
E-MAIL			
START DATE		END DATE	

STORM WATER SAMPLING AGENT:			
CONTACT PERSON		TITLE:	
ADDRESS			
CITY		STATE	ZIP
TELEPHONE			
EMERGENCY TELEPHONE			
FAX			
E-MAIL			
START DATE		END DATE	

STORM WATER SAMPLING AGENT:			
CONTACT PERSON		TITLE:	
ADDRESS			
CITY		STATE	ZIP
TELEPHONE			
EMERGENCY TELEPHONE			
FAX			
E-MAIL			
START DATE		END DATE	

STORM WATER SAMPLING AGENT:			
CONTACT PERSON		TITLE:	
ADDRESS			
CITY		STATE	ZIP
TELEPHONE			
EMERGENCY TELEPHONE			
FAX			
E-MAIL			
START DATE		END DATE	

REGIONAL BOARD CONTACT INFORMATION		RQWQB NAME:	
CONTACT PERSON		TITLE:	
ADDRESS			
CITY		STATE	ZIP
TELEPHONE			
EMERGENCY TELEPHONE			
FAX			
E-MAIL			

LOCAL STORM WATER MANAGEMENT AGENCY		AGENCY NAME:	
CONTACT PERSON		TITLE:	
ADDRESS			
CITY		STATE	ZIP
TELEPHONE			
EMERGENCY TELEPHONE			
FAX			
E-MAIL			

<input type="checkbox"/> CONTRACTOR <input type="checkbox"/> SUBCONTRACTOR <input type="checkbox"/> INDIVIDUAL DIRECTED BY QSP <input type="checkbox"/> OTHER			
PLEASE CHECK APPROPRIATE BOX ABOVE. IF "OTHER", PLEASE INDICATE:			
COMPANY NAME			
CONTACT PERSON		TITLE:	
ADDRESS			
CITY	STATE	ZIP	
TELEPHONE			
EMERGENCY TELEPHONE			
FAX			
E-MAIL			
START DATE	END DATE		

<input type="checkbox"/> CONTRACTOR <input type="checkbox"/> SUBCONTRACTOR <input type="checkbox"/> INDIVIDUAL DIRECTED BY QSP <input type="checkbox"/> OTHER			
PLEASE CHECK APPROPRIATE BOX ABOVE. IF "OTHER", PLEASE INDICATE:			
NAME	TITLE:		
ADDRESS			
CITY	STATE	ZIP	
TELEPHONE			
EMERGENCY TELEPHONE			
FAX			
E-MAIL			
START DATE	END DATE		

<input type="checkbox"/> CONTRACTOR <input type="checkbox"/> SUBCONTRACTOR <input type="checkbox"/> INDIVIDUAL DIRECTED BY QSP <input type="checkbox"/> OTHER			
PLEASE CHECK APPROPRIATE BOX ABOVE. IF "OTHER", PLEASE INDICATE:			
NAME	TITLE:		
ADDRESS			
CITY	STATE	ZIP	
TELEPHONE			
EMERGENCY TELEPHONE			
FAX			
E-MAIL			
START DATE	END DATE		

<input type="checkbox"/> CONTRACTOR <input type="checkbox"/> SUBCONTRACTOR <input type="checkbox"/> INDIVIDUAL DIRECTED BY QSP <input type="checkbox"/> OTHER				
PLEASE CHECK APPROPRIATE BOX ABOVE. IF "OTHER", PLEASE INDICATE:				
NAME			TITLE:	
ADDRESS				
CITY	STATE	ZIP		
TELEPHONE				
EMERGENCY TELEPHONE				
FAX				
E-MAIL				
START DATE	END DATE			

<input type="checkbox"/> CONTRACTOR <input type="checkbox"/> SUBCONTRACTOR <input type="checkbox"/> INDIVIDUAL DIRECTED BY QSP <input type="checkbox"/> OTHER				
PLEASE CHECK APPROPRIATE BOX ABOVE. IF "OTHER", PLEASE INDICATE:				
NAME			TITLE:	
ADDRESS				
CITY	STATE	ZIP		
TELEPHONE				
EMERGENCY TELEPHONE				
FAX				
E-MAIL				
START DATE	END DATE			

<input type="checkbox"/> CONTRACTOR <input type="checkbox"/> SUBCONTRACTOR <input type="checkbox"/> INDIVIDUAL DIRECTED BY QSP <input type="checkbox"/> OTHER				
PLEASE CHECK APPROPRIATE BOX ABOVE. IF "OTHER", PLEASE INDICATE:				
NAME			TITLE:	
ADDRESS				
CITY	STATE	ZIP		
TELEPHONE				
EMERGENCY TELEPHONE				
FAX				
E-MAIL				
START DATE	END DATE			

<input type="checkbox"/> CONTRACTOR <input type="checkbox"/> SUBCONTRACTOR <input type="checkbox"/> INDIVIDUAL DIRECTED BY QSP <input type="checkbox"/> OTHER				
PLEASE CHECK APPROPRIATE BOX ABOVE. IF "OTHER", PLEASE INDICATE:				
NAME			TITLE:	
ADDRESS				
CITY	STATE	ZIP		
TELEPHONE				
EMERGENCY TELEPHONE				
FAX				
E-MAIL				
START DATE	END DATE			

<input type="checkbox"/> CONTRACTOR <input type="checkbox"/> SUBCONTRACTOR <input type="checkbox"/> INDIVIDUAL DIRECTED BY QSP <input type="checkbox"/> OTHER				
PLEASE CHECK APPROPRIATE BOX ABOVE. IF "OTHER", PLEASE INDICATE:				
NAME			TITLE:	
ADDRESS				
CITY	STATE	ZIP		
TELEPHONE				
EMERGENCY TELEPHONE				
FAX				
E-MAIL				
START DATE	END DATE			

<input type="checkbox"/> CONTRACTOR <input type="checkbox"/> SUBCONTRACTOR <input type="checkbox"/> INDIVIDUAL DIRECTED BY QSP <input type="checkbox"/> OTHER				
PLEASE CHECK APPROPRIATE BOX ABOVE. IF "OTHER", PLEASE INDICATE:				
NAME			TITLE:	
ADDRESS				
CITY	STATE	ZIP		
TELEPHONE				
EMERGENCY TELEPHONE				
FAX				
E-MAIL				
START DATE	END DATE			

Appendix XIV

Inspection Checklists

Appendix XV

Training Documentation

SWPPP Preparer's Training Log

Name of Person Attending Training Workshop	Date of Training Workshop	Title of Training Workshop	Location of Training Workshop
Tracy Beach	July 14-15, 2011	Low Impact Development Applications for Water Resource Management by Rod Frederick and Aaron Poresky with ASCE	San Diego, CA
Tracy Beach	February 15 – 17, 2011	QSD/QSP Training by Michael Alberson	San Diego, CA
Tracy Beach	April 8, 2010	Statewide Construction General Permit Overview Workshop by the SWRCB	Carlsbad, CA
Tracy Beach	March 3, 2010	San Diego County Model Standard Urban Stormwater Mitigation Plan (SUSMP) Seminar	San Diego, CA
Tracy Beach	February 25, 2010	Understanding the New State Water Board General Construction Permit Presented by Gerald R. Montgomery, Senior Manager, Interwest	San Diego, CA
Tracy Beach	April 22, 2008	Watershed-Friendly “Low Impact Development” Site Design & Permeable Pavements for Stormwater Management	Newport Beach, CA
Tracy Beach	March 25, 2008	Low Impact Development (LID) Seminar by Filterra Speaker Larry Coffman	Bonita, CA
Tracy Beach	February 28, 2008	National City SUSMP Workshop	National City, CA
Tracy Beach	November 19, 2007	San Diego Regional Stormwater Copermittees-Interim Hydromodification Plan/SUSMP Workshop for County of San Diego	San Diego, CA
Tracy Beach	November 6, 8 & 13, 2007	Construction Storm Water Compliance and Storm Water Pollution Prevention Plan Training Seminar by	San Diego, CA

SWPPP Preparer's Training Log

		the San Diego Building Industry Association (BIA)	
--	--	---	--

CERTIFICATE OF TRAINING

CALIFORNIA CONSTRUCTION GENERAL PERMIT

QUALIFIED SWPPP DEVELOPER (QSD) AND QUALIFIED SWPPP PRACTITIONER (QSP)

Tracy Beach

Aug 30, 2011 - Aug 30, 2013

Certificate # 20216



California Stormwater Quality Association and
California Construction General Permit Training Team

Appendix XVI

Amendment Log

Appendix XVII

Reports

Appendix XVIII

Secondary Containment and Spill Kit Inventory

Appendix XIX

Other SWPPP Exhibits





4460 Carlsbad Blvd, Carlsbad, CA, United States
Address is approximate

« P







Appendix XX

Active Treatment Systems

Active Treatment System (ATS)

Not Applicable

Appendix XXI

Bioassessment

Bioassessment

Not Applicable

Appendix XXII

Glossary / Acronyms

**Glossary and Acronym List are taken from the SWRCB Order
No.2009-0009-DWQ NPDES General Permit**

APPENDIX 5: Glossary

Active Areas of Construction

All areas subject to land surface disturbance activities related to the project including, but not limited to, project staging areas, immediate access areas and storage areas. All previously active areas are still considered active areas until final stabilization is complete. [The construction activity Phases used in this General Permit are the Preliminary Phase, Grading and Land Development Phase, Streets and Utilities Phase, and the Vertical Construction Phase.]

Active Treatment System (ATS)

A treatment system that employs chemical coagulation, chemical flocculation, or electrocoagulation to aid in the reduction of turbidity caused by fine suspended sediment.

Acute Toxicity Test

A chemical stimulus severe enough to rapidly induce a negative effect; in aquatic toxicity tests, an effect observed within 96 hours or less is considered acute.

Air Deposition

Airborne particulates from construction activities. .

Approved Signatory

A person who has legal authority to sign, certify, and electronically submit Permit Registration Documents and Notices of Termination on behalf of the Legally Responsible Person.

Beneficial Uses

As defined in the California Water Code, beneficial uses of the waters of the state that may be protected against quality degradation include, but are not limited to, domestic, municipal, agricultural and industrial supply; power generation; recreation; aesthetic enjoyment; navigation; and preservation and enhancement of fish, wildlife, and other aquatic resources or preserves.

Best Available Technology Economically Achievable (BAT)

As defined by USEPA, BAT is a technology-based standard established by the Clean Water Act (CWA) as the most appropriate means available on a national basis for controlling the direct discharge of toxic and nonconventional pollutants to navigable waters. The BAT effluent limitations guidelines, in general, represent the best existing performance of treatment technologies that are economically achievable within an industrial point source category or subcategory.

Best Conventional Pollutant Control Technology (BCT)

As defined by USEPA, BCT is a technology-based standard for the discharge from existing industrial point sources of conventional pollutants including biochemical oxygen demand (BOD), total suspended sediment (TSS), fecal coliform, pH, oil and grease.

Best Professional Judgment (BPJ)

The method used by permit writers to develop technology-based NPDES permit conditions on a case-by-case basis using all reasonably available and relevant data.

Best Management Practices (BMPs)

BMPs are scheduling of activities, prohibitions of practices, maintenance procedures, and other management practices to prevent or reduce the discharge of pollutants. BMPs also include treatment requirements, operating procedures, and practices to control site runoff, spillage or leaks, sludge or waste disposal, or drainage from raw material storage.

Chain of Custody (COC)

Form used to track sample handling as samples progress from sample collection to the analytical laboratory. The COC is then used to track the resulting analytical data from the laboratory to the client. COC forms can be obtained from an analytical laboratory upon request.

Coagulation

The clumping of particles in a discharge to settle out impurities, often induced by chemicals such as lime, alum, and iron salts.

Common Plan of Development

Generally a contiguous area where multiple, distinct construction activities may be taking place at different times under one plan. A plan is generally defined as any piece of documentation or physical demarcation that indicates that construction activities may occur on a common plot. Such documentation could consist of a tract map, parcel map, demolition plans, grading plans or contract documents. Any of these documents could delineate the boundaries of a common plan area. However, broad planning documents, such as land use master plans, conceptual master plans, or broad-based CEQA or NEPA documents that identify potential projects for an agency or facility are not considered common plans of development.

Daily Average Discharge

The discharge of a pollutant measured during any 24-hour period that reasonably represents a calendar day for purposes of sampling. For pollutants with limitations expressed in units of mass, the daily discharge is calculated as the total mass of the pollutant discharged during the day. For pollutants with limitations expressed in other units of measurement (e.g., concentration) the daily discharge is calculated as the average measurement of the pollutant

throughout the day (40 CFR 122.2). In the case of pH, the pH must first be converted from a log scale.

Debris

Litter, rubble, discarded refuse, and remains of destroyed inorganic anthropogenic waste.

Direct Discharge

A discharge that is routed directly to waters of the United States by means of a pipe, channel, or ditch (including a municipal storm sewer system), or through surface runoff.

Discharger

The Legally Responsible Person (see definition) or entity subject to this General Permit.

Dose Rate (for ATS)

In exposure assessment, dose (e.g. of a chemical) per time unit (e.g. mg/day), sometimes also called dosage.

Drainage Area

The area of land that drains water, sediment, pollutants, and dissolved materials to a common outlet.

Effluent

Any discharge of water by a discharger either to the receiving water or beyond the property boundary controlled by the discharger.

Effluent Limitation

Any numeric or narrative restriction imposed on quantities, discharge rates, and concentrations of pollutants which are discharged from point sources into waters of the United States, the waters of the contiguous zone, or the ocean.

Erosion

The process, by which soil particles are detached and transported by the actions of wind, water, or gravity.

Erosion Control BMPs

Vegetation, such as grasses and wildflowers, and other materials, such as straw, fiber, stabilizing emulsion, protective blankets, etc., placed to stabilize areas of disturbed soils, reduce loss of soil due to the action of water or wind, and prevent water pollution.

Field Measurements

Testing procedures performed in the field with portable field-testing kits or meters.

Final Stabilization

All soil disturbing activities at each individual parcel within the site have been completed in a manner consistent with the requirements in this General Permit.

First Order Stream

Stream with no tributaries.

Flocculants

Substances that interact with suspended particles and bind them together to form flocs.

Good Housekeeping BMPs

BMPs designed to reduce or eliminate the addition of pollutants to construction site runoff through analysis of pollutant sources, implementation of proper handling/disposal practices, employee education, and other actions.

Grading Phase (part of the Grading and Land Development Phase)

Includes reconfiguring the topography and slope including; alluvium removals; canyon cleanouts; rock undercuts; keyway excavations; land form grading; and stockpiling of select material for capping operations.

Hydromodification

Hydromodification is the alteration of the hydrologic characteristics of coastal and non-coastal waters, which in turn could cause degradation of water resources. Hydromodification can cause excessive erosion and/or sedimentation rates, causing excessive turbidity, channel aggradation and/or degradation.

Identified Organisms

Organisms within a sub-sample that is specifically identified and counted.

Inactive Areas of Construction

Areas of construction activity that are not active and those that have been active and are not scheduled to be re-disturbed for at least 14 days.

Index Period

The period of time during which bioassessment samples must be collected to produce results suitable for assessing the biological integrity of streams and rivers. Instream communities naturally vary over the course of a year, and sampling during the index period ensures that samples are collected during a time frame when communities are stable so that year-to-year consistency is obtained. The index period approach provides a cost-effective alternative to year-round sampling. Furthermore, sampling within the appropriate index period will yield results that are comparable to the assessment thresholds or criteria for a given region, which are established for the same index period. Because index

periods differ for different parts of the state, it is essential to know the index period for your area.

K Factor

The soil erodibility factor used in the Revised Universal Soil Loss Equation (RUSLE). It represents the combination of detachability of the soil, runoff potential of the soil, and the transportability of the sediment eroded from the soil.

Legally Responsible Person

The person who possesses the title of the land or the leasehold interest of a mineral estate upon which the construction activities will occur for the regulated site. For linear underground/overhead projects, it is in the person in charge of the utility company, municipality, or other public or private company or agency that owns or operates the LUP.

Likely Precipitation Event

Any weather pattern that is forecasted to have a 50% or greater chance of producing precipitation in the project area. The discharger shall obtain likely precipitation forecast information from the National Weather Service Forecast Office (e.g., by entering the zip code of the project's location at <http://www.srh.noaa.gov/forecast>).

Maximum Allowable Threshold Concentration (MATC)

The allowable concentration of residual, or dissolved, coagulant/flocculant in effluent. The MATC shall be coagulant/flocculant-specific, and based on toxicity testing conducted by an independent, third-party laboratory. A typical MATC would be:

The MATC is equal to the geometric mean of the NOEC (No Observed Effect Concentration) and LOEC (Lowest Observed Effect Concentration) Acute and Chronic toxicity results for most sensitive species determined for the specific coagulant. The most sensitive species test shall be used to determine the MATC.

Natural Channel Evolution

The physical trend in channel adjustments following a disturbance that causes the river to have more energy and degrade or aggrade more sediment. Channels have been observed to pass through 5 to 9 evolution types. Once they pass through the suite of evolution stages, they will rest in a new state of equilibrium.

Non-Storm Water Discharges

Discharges are discharges that do not originate from precipitation events. They can include, but are not limited to, discharges of process water, air conditioner condensate, non-contact cooling water, vehicle wash water, sanitary wastes, concrete washout water, paint wash water, irrigation water, or pipe testing water.

Non-Visible Pollutants

Pollutants associated with a specific site or activity that can have a negative impact on water quality, but cannot be seen through observation (ex: chlorine). Such pollutants being discharged are not authorized.

Numeric Action Level (NAL)

Level is used as a warning to evaluate if best management practices are effective and take necessary corrective actions. Not an effluent limit.

Original Sample Material

The material (i.e., macroinvertebrates, organic material, gravel, etc.) remaining after the subsample has been removed for identification.

pH

Unit universally used to express the intensity of the acid or alkaline condition of a water sample. The pH of natural waters tends to range between 6 and 9, with neutral being 7. Extremes of pH can have deleterious effects on aquatic systems.

Post-Construction BMPs

Structural and non-structural controls which detain, retain, or filter the release of pollutants to receiving waters after final stabilization is attained.

Preliminary Phase (Pre-Construction Phase - Part of the Grading and Land Development Phase)

Construction stage including rough grading and/or disking, clearing and grubbing operations, or any soil disturbance prior to mass grading.

Project**Qualified SWPPP Developer**

Individual who is authorized to develop and revise SWPPPs.

Qualified SWPPP Practitioner

Individual assigned responsibility for non-storm water and storm water visual observations, sampling and analysis, and responsibility to ensure full compliance with the permit and implementation of all elements of the SWPPP, including the preparation of the annual compliance evaluation and the elimination of all unauthorized discharges.

Qualifying Rain Event

Any event that produces 0.5 inches or more precipitation with a 48 hour or greater period between rain events.

R Factor

Erosivity factor used in the Revised Universal Soil Loss Equation (RUSLE). The R factor represents the erosivity of the climate at a particular location. An

average annual value of R is determined from historical weather records using erosivity values determined for individual storms. The erosivity of an individual storm is computed as the product of the storm's total energy, which is closely related to storm amount, and the storm's maximum 30-minute intensity.

Rain Event Action Plan (REAP)

Written document, specific for each rain event, that when implemented is designed to protect all exposed portions of the site within 48 hours of any likely precipitation event.

Remaining Sub sampled Material

The material (e.g., organic material, gravel, etc.) that remains after the organisms to be identified have been removed from the subsample for identification. (Generally, no macroinvertebrates are present in the remaining subsampled material, but the sample needs to be checked and verified using a complete Quality Assurance (QA) plan)

Routine Maintenance

Activities intended to maintain the original line and grade, hydraulic capacity, or original purpose of a facility.

Runoff Control BMPs

Measures used to divert runoff from offsite and runoff within the site.

Run-on

Discharges that originate offsite and flow onto the property of a separate project site.

Revised Universal Soil Loss Equation (RUSLE)

Empirical model that calculates average annual soil loss as a function of rainfall and runoff erosivity, soil erodibility, topography, erosion controls, and sediment controls.

Sampling and Analysis Plan

Document that describes how the samples will be collected, under what conditions, where and when the samples will be collected, what the sample will be tested for, what test methods and detection limits will be used, and what methods/procedures will be maintained to ensure the integrity of the sample during collection, storage, shipping and testing (i.e., quality assurance/quality control protocols).

Sediment

Solid particulate matter, both mineral and organic, that is in suspension, is being transported, or has been moved from its site of origin by air, water, gravity, or ice and has come to rest on the earth's surface either above or below sea level.

Sedimentation

Process of deposition of suspended matter carried by water, wastewater, or other liquids, by gravity. It is usually accomplished by reducing the velocity of the liquid below the point at which it can transport the suspended material.

Sediment Control BMPs

Practices that trap soil particles after they have been eroded by rain, flowing water, or wind. They include those practices that intercept and slow or detain the flow of storm water to allow sediment to settle and be trapped (e.g., silt fence, sediment basin, fiber rolls, etc.).

Settleable Solids (SS)

Solid material that can be settled within a water column during a specified time frame. It is typically tested by placing a water sample into an Imhoff settling cone and then allowing the solids to settle by gravity for a given length of time.

Results are reported either as a volume (mL/L) or a mass (mg/L) concentration.

Sheet Flow

Flow of water that occurs overland in areas where there are no defined channels where the water spreads out over a large area at a uniform depth.

Site**Soil Amendment**

Any material that is added to the soil to change its chemical properties, engineering properties, or erosion resistance that could become mobilized by storm water.

Streets and Utilities Phase

Construction stage including excavation and street paving, lot grading, curbs, gutters and sidewalks, public utilities, public water facilities including fire hydrants, public sanitary sewer systems, storm sewer system and/or other drainage improvements.

Structural Controls

Any structural facility designed and constructed to mitigate the adverse impacts of storm water and urban runoff pollution

Suspended Sediment Concentration (SSC)

The measure of the concentration of suspended solid material in a water sample by measuring the dry weight of all of the solid material from a known volume of a collected water sample. Results are reported in mg/L.

Total Suspended Solids (TSS)

The measure of the suspended solids in a water sample includes inorganic substances, such as soil particles and organic substances, such as algae,

aquatic plant/animal waste, particles related to industrial/sewage waste, etc. The TSS test measures the concentration of suspended solids in water by measuring the dry weight of a solid material contained in a known volume of a sub-sample of a collected water sample. Results are reported in mg/L.

Toxicity

The adverse response(s) of organisms to chemicals or physical agents ranging from mortality to physiological responses such as impaired reproduction or growth anomalies.

Turbidity

The cloudiness of water quantified by the degree to which light traveling through a water column is scattered by the suspended organic and inorganic particles it contains. The turbidity test is reported in Nephelometric Turbidity Units (NTU) or Jackson Turbidity Units (JTU).

Vertical Construction Phase

The Build out of structures from foundations to roofing, including rough landscaping.

Waters of the United States

Generally refers to surface waters, as defined by the federal Environmental Protection Agency in 40 C.F.R. § 122.2.¹

Water Quality Objectives (WQO)

Water quality objectives are defined in the California Water Code as limits or levels of water quality constituents or characteristics, which are established for the reasonable protection of beneficial uses of water or the prevention of nuisance within a specific area.

¹ The application of the definition of “waters of the United States” may be difficult to determine; there are currently several judicial decisions that create some confusion. If a landowner is unsure whether the discharge must be covered by this General Permit, the landowner may wish to seek legal advice.

APPENDIX 6: Acronym List

ASBS	Areas of Special Biological Significance
ASTM	American Society of Testing and Materials; Standard Test Method for Particle-Size Analysis of Soils
ATS	Active Treatment System
BASMAA	Bay Area Storm water Management Agencies Association
BAT	Best Available Technology Economically Achievable
BCT	Best Conventional Pollutant Control Technology
BMP	Best Management Practices
BOD	Biochemical Oxygen Demand
BPJ	Best Professional Judgment
CAFO	Confined Animal Feeding Operation
CCR	California Code of Regulations
CEQA	California Environmental Quality Act
CFR	Code of Federal Regulations
CGP	NPDES General Permit for Storm Water Discharges Associated with Construction Activities
CIWQS	California Integrated Water Quality System
CKD	Cement Kiln Dust
COC	Chain of Custody
CPESC	Certified Professional in Erosion and Sediment Control
CPSWQ	Certified Professional in Storm Water Quality
CSMP	Construction Site Monitoring Program
CTB	Cement Treated Base
CTR	California Toxics Rule
CWA	Clean Water Act
CWC	California Water Code
CWP	Center for Watershed Protection
DADMAC	Diallyldimethyl-ammonium chloride
DDNR	Delaware Department of Natural Resources
DFG	Department of Fish and Game
DHS	Department of Health Services
DWQ	Division of Water Quality
EC	Electrical Conductivity
ELAP	Environmental Laboratory Accreditation Program
EPA	Environmental Protection Agency
ESA	Environmentally Sensitive Area
ESC	Erosion and Sediment Control
HSPF	Hydrologic Simulation Program Fortran
JTU	Jackson Turbidity Units
LID	Low Impact Development
LOEC	Lowest Observed Effect Concentration
LRP	Legally Responsible Person
LUP	Linear Underground/Overhead Projects

MATC	Maximum Allowable Threshold Concentration
MDL	Method Detection Limits
MRR	Monitoring and Reporting Requirements
MS4	Municipal Separate Storm Sewer System
MUSLE	Modified Universal Soil Loss Equation
NAL	Numeric Action Level
NEL	Numeric Effluent Limitation
NICET	National Institute for Certification in Engineering Technologies
NOAA	National Oceanic and Atmospheric Administration
NOEC	No Observed Effect Concentration
NOI	Notice of Intent
NOT	Notice of Termination
NPDES	National Pollutant Discharge Elimination System
NRCS	Natural Resources Conservation Service
NTR	National Toxics Rule
NTU	Nephelometric Turbidity Units
O&M	Operation and Maintenance
PAC	Polyaluminum chloride
PAM	Polyacrylamide
PASS	Polyaluminum chloride Silica/sulfate
POC	Pollutants of Concern
PoP	Probability of Precipitation
POTW	Publicly Owned Treatment Works
PRDs	Permit Registration Documents
PWS	Planning Watershed
QAMP	Quality Assurance Management Plan
QA/QC	Quality Assurance/Quality Control
REAP	Rain Event Action Plan
Regional Board	Regional Water Quality Control Board
ROWD	Report of Waste Discharge
RUSLE	Revised Universal Soil Loss Equation
RW	Receiving Water
SMARTS System	Storm water Multi Application Reporting and Tracking System
SS	Settleable Solids
SSC	Suspended Sediment Concentration
SUSMP	Standard Urban Storm Water Mitigation Plan
SW	Storm Water
SWARM	Storm Water Annual Report Module
SWAMP	Surface Water Ambient Monitoring Program
SWMM	Storm Water Management Model
SWMP	Storm Water Management Program
SWPPP	Storm Water Pollution Prevention Plan
TC	Treatment Control
TDS	Total Dissolved Solids

TMDL	Total Maximum Daily Load
TSS	Total Suspended Solids
USACOE	U.S. Army Corps of Engineers
USC	United States Code
USEPA	United States Environmental Protection Agency
USGS	United States Geological Survey
WDID	Waste Discharge Identification Number
WDR	Waste Discharge Requirements
WLA	Waste Load Allocation
WET	Whole Effluent Toxicity
WRCC	Western Regional Climate Center
WQBEL	Water Quality Based Effluent Limitation
WQO	Water Quality Objective
WQS	Water Quality Standard