**SAN DIEGO GAS & ELECTRIC COMPANY
CLEVELAND NATIONAL FOREST
POWER LINE REPLACEMENT PROJECTS
EROSION CONTROL PLAN**

MARCH 2017

PREPARED BY:



PREPARED FOR:



TABLE OF CONTENTS

1 – INTRODUCTION..... 1

2 – OBJECTIVES 1

3 – MITIGATION MEASURE..... 2

4 – SOIL EROSION CONTROL PRACTICES AND PROCEDURES 2

 4.0 Erosion Control Methods3

 4.1 SWPPP Implementation and Erosion Control Inspection During Construction10

 4.2 Post-Construction Long-Term Stabilization.....12

 4.3 Post-Construction Operation and Maintenance Procedures13

5 – REFERENCES..... 14

LIST OF TABLES

Table 1: Erosion Control Methods..... 4

Table 2: Maximum Waterbar Spacing 6

Table 3: Discharge Rate, Apron Length and Rock Diameter 8

Table 4: Fiber Roll Spacing for Slope Application 8

Table 5: CGP Inspection Requirements for Linear Underground/Overhead Projects..... 11

LIST OF ATTACHMENTS

- Attachment A: USFS Soil and Water Conservation Handbook Erosion Control BMPs
- Attachment B: USFS National Core BMP Technical Guide
- Attachment C: SDG&E Soil Erosion Control BMP Details
- Attachment D: SWPPP BMP Site Maps

1 – INTRODUCTION

This Erosion Control Plan (ECP) describes the measures that will be taken by San Diego Gas & Electric Company (SDG&E) and its contractors to ensure that soil erosion resulting from the Cleveland National Forest Power Line Replacement Projects (Project) is minimized to the greatest extent feasible. The Project includes a variety of activities in support of the following construction components:

- replacement of approximately 1,400 existing wood poles with fire-resistant, weathered steel poles;
- undergrounding of approximately 26 miles of existing 12 kilovolt (kV) distribution lines;
- removal of approximately 30 miles of existing 12 kV and 19 miles of existing 69 kV overhead facilities; and
- closure of approximately 24 miles of access roads.

This ECP was prepared in accordance with Mitigation Measure (MM) HYD-1, as described in the Project's Final Environmental Impact Report/Environmental Impact Statement's Mitigation Monitoring, Compliance, and Reporting Program (MMCRP) and the United States (U.S.) Forest Service (USFS) Record of Decision (ROD).

2 – OBJECTIVES

This ECP provides Project-specific erosion control methods and procedures that will be implemented in conjunction with the site-specific Storm Water Pollution Prevention Plans (SWPPPs) and Habitat Restoration Plan (HRP) for the Project to prevent and control soil erosion during construction, operation, and maintenance activities.¹ Erosion control practices and measures in this ECP are specifically intended to accomplish the following objectives:

- Prevent and control soil erosion during construction, operation, and maintenance activities.
- Incorporate the USFS's National Best Management Practices (BMPs) for Water Quality Management on National Forest System Lands into the Project-specific soil erosion control practices and procedures, as described in Section 4 – Soil Erosion Control Practices and Procedures.
- Provide consistency between the ECP and SDG&E's Subregional Natural Communities Conservation Plan (NCCP) Operational Protocols.

¹ The site-specific SWPPPs and HRP are separate deliverables that will be prepared and submitted to the California Public Utilities Commission (CPUC) and USFS prior to the Notice to Proceed (NTP) issuance for each segment of the Project.

3 – MITIGATION MEASURE

MM HYD-1, included in the Project’s MMCRP and ROD, requires preparation and implementation of this ECP. MM HYD-1 and the methods described in this ECP are applicable during construction, operation, and maintenance activities associated with the Project.

MM HYD-1 states:

“SDG&E shall develop and implement an Erosion Control Plan (ECP) for construction, operations, and maintenance activities in order to prevent and control soil erosion and gullyng. The ECP shall include Forest Service best management practices specific to re-vegetation requirements (scarifying the soil, and fertilizing, seeding and/or mulching, as required to achieve proper post-construction site stabilization) and incorporate Construction General Permit SWPPP requirements for each construction segment as the SWPPP(s) for that segment are completed. Additionally, the ECP shall complement restoration goals and objectives identified in the Habitat Restoration Plan, as required under MM BIO-4. The ECP shall be updated for each construction segment and provided to the CPUC and the federal agencies for review and approval prior to each agency’s Notice to Proceed issuance for that construction segment.

As required by the Construction General Permit, SDG&E shall develop a Storm Water Pollution Prevention Plan (SWPPP) for the Project or for individual construction segments, as required, to prevent and control reduce the amount of sediment and other pollutants in storm water discharges associated with land disturbing activities during construction. The SWPPP(s) and verification of submittal to the RWQCB shall be submitted to the CPUC and Forest Service prior to Notice to Proceed issuance for the respective construction segment. SDG&E shall provide the CPUC and Forest Service with subsequent amendments to the SWPPP as part of SDG&E’s weekly compliance reports. In weekly construction compliance reports, SDG&E shall note when Storm Water Construction Site Inspection Report Forms have been posted to the Storm Water Multiple Application and Report Tracking System (SMARTS) following storm events.”

4 – SOIL EROSION CONTROL PRACTICES AND PROCEDURES

Specific erosion control methods that will be implemented on the Project to mitigate soil erosion and gullyng during construction are described in the following subsections. The erosion control methods described herein are consistent with the operational protocols contained within Section 7 Operational Protocols of SDG&E’s Subregional NCCP. Specifically, Section 7.1.4 Maintenance, Repair and Construction of Facilities of the Subregional NCCP contains operational protocols that pertain to this ECP, and includes the following:

- “Maintenance, repair and construction activities shall be designed and implemented to minimize new disturbance, erosion on manufactured and other slopes, and off-site degradation from accelerated sedimentation, and to reduce maintenance and repair cost.”

- “Erosion will be minimized on access roads and other locations primarily with water bars. The water bars are mounds of soil shaped to direct flow and prevent erosion.”
- “Hydrologic impact will be minimized through the use of state-of-the-art technical design and construction techniques to minimize ponding, eliminate flood hazards, and avoid erosion and siltation into any creeks, streams, rivers, or bodies of water by use of Best Management Practices.”

4.0 EROSION CONTROL METHODS

The erosion control methods described in the following subsections are consistent with the USFS’s Soil and Water Conservation Handbook (R5 FSH 2509.22) for the Southwest Region (Region 5) (USFS Handbook) and the National Core BMP Technical Guide (Volume 1, FS-990a) (USFS National Core BMPs). BMPs from the USFS Handbook that are relevant to this ECP are included in Attachment A: USFS Soil and Water Conservation Handbook Erosion Control BMPs.² The USFS Soil and Water Conservation Handbook provides guidance to effectively limit and mitigate erosion during road maintenance and operations, as well as during and immediately following vegetation manipulation associated with Project activities. Additionally, Attachment B: USFS National Core BMP Technical Guide contains National Core BMPs that will be implemented as necessary during Project construction, operation, and maintenance activities to minimize and control erosion.

The structural and non-structural erosion control methods proposed for implementation on the Project are summarized in Table 1: Erosion Control Methods, and are discussed in more detail in the following subsections. Table 1: Erosion Control Methods lists the SDG&E soil erosion control BMP, the applicable USFS Handbook BMP, and the corresponding USFS National Core BMPs³ for each erosion control method. Attachment C: SDG&E Soil Erosion Control BMP Details provides a thorough description of the erosion control methods proposed for the Project, as well as installation and maintenance procedures and representative photographs.

The soil erosion control BMP details in Attachment C: SDG&E Soil Erosion Control BMP Details are sourced from the SDG&E BMP Manual for Water Quality Construction (BMP Manual). The SDG&E BMP Manual integrates the best and most practical pollution prevention features that are applicable to utility construction activities from several sources (e.g., the State Water Resources Control Board [SWRCB], the California Stormwater Quality Association, local municipalities, and the California Department of Transportation BMP manuals), which are also compliant with applicable regulations and ordinances. Additionally, the implementation of the erosion control methods described within this document will satisfy the Construction General Permit’s (CGP’s) (Order No: 2009-0009-DWQ as amended by 2010-0014-DWQ) SWPPP requirements.

² USFS Handbook BMPs are programmatic and are intended to lead to on-the-ground, site-specific BMP prescriptions, but are not intended to be such prescriptions themselves. The USFS programmatic BMPs include practices and standards, rather than specific erosion control structures or methods.

³ National Core General Planning BMPs (i.e., Plan-1, Plan-2, and Plan-3) are applicable to all structural and non-structural BMPs proposed for implementation on the Project.

Table 1: Erosion Control Methods

Erosion Control Method	Corresponding SDG&E BMP(s)	Applicable USFS Handbook BMP(s)	Applicable USFS National Core BMP
Preservation of Existing Vegetation	BMP 4-01 – Preservation of Existing Vegetation	BMP 2.4 – Road Maintenance and Operations	<ul style="list-style-type: none"> • AqEco-2 – Operations in Aquatic Ecosystems • Fac-9 – Pipelines, Transmission Facilities, and Rights-of-Way • Veg-1 – Vegetation Management Planning • Veg-2 – Erosion Prevention and Control • Veg-4 – Ground-Based Skidding and Yarding Operations • Veg-8 – Mechanical Site Treatment • Road-9 – Parking and Staging Areas
Waterbars	BMP 4-09 – Diversion Berms and Drainage Swales	BMP 2.4 – Road Maintenance and Operations	<ul style="list-style-type: none"> • Fac-9 – Pipelines, Transmission Facilities, and Rights-of-Way • Road-4 – Road Operations and Maintenance
Velocity Dissipation Devices	BMP 4-10 – Velocity Dissipation Devices	BMP 2.4 – Road Maintenance and Operations	<ul style="list-style-type: none"> • AqEco-4 – Stream Channels and Shorelines • Fac-9 – Pipelines, Transmission Facilities, and Rights-of-Way • Road-4 – Road Operations and Maintenance • Road-11 – Road Storm-Damage Surveys
Decompaction	BMP 4-13 – Soil Preparation	BMP 5.1 – Soil-disturbing Treatments on the Contour	<ul style="list-style-type: none"> • Fac-9 – Pipelines, Transmission Facilities, and Rights-of-Way • Road-6 – Road Storage and Decommissioning
Fiber Rolls	BMP 4-02 – Temporary Soil Stabilization	BMP 5.1 – Soil-disturbing Treatments on the Contour	<ul style="list-style-type: none"> • Fac-9 – Pipelines, Transmission Facilities, and Rights-of-Way • Road-4 – Road Operations and Maintenance
Erosion Control Matting	BMP 4-07 – Geotextiles, Plastic Covers, and Erosion Control Blankets/Mats	BMP 5.4 – Revegetation of Surface-disturbed Areas	<ul style="list-style-type: none"> • AqEco-4 – Stream Channels and Shorelines • Fac-9 – Pipelines, Transmission Facilities, and Rights-of-Way • Road-4 – Road Operations and Maintenance
Hydraulic Mulch and Hydroseeding	BMP 4-03 – Hydraulic Mulch BMP 4-04 – Hydroseeding BMP 4-05 – Soil Binders	BMP 5.4 – Revegetation of Surface-disturbed Areas	<ul style="list-style-type: none"> • Fac-9 – Pipelines, Transmission Facilities, and Rights-of-Way

Erosion Control Method	Corresponding SDG&E BMP(s)	Applicable USFS Handbook BMP(s)	Applicable USFS National Core BMP
Wind Erosion Control	BMP 4-08 – Dust (Wind Erosion) Control	BMP 2.4 – Road Maintenance and Operations	<ul style="list-style-type: none"> • Fac-9 – Pipelines, Transmission Facilities, and Rights-of-Way

4.0.0 Preservation of Existing Vegetation

Preservation of existing vegetation is a procedural erosion control method that maximizes the preservation of existing trees, shrubs, bushes, and grasses during construction activities. Implementation of this erosion control method will ensure that limits of disturbance and areas to be preserved are clearly demarcated prior to clearing and grubbing or other soil disturbance activities. SDG&E’s designated Qualified SWPPP Practitioner (QSP) or Environmental Inspectors (EIs) will oversee the initial stakeout of Project limits, clearly define work areas with signage and fencing, and will make certain that vegetation is preserved to the maximum extent feasible.

Barriers or fencing that demarcate the limits of disturbance for active work areas will be inspected daily by the designated QSP or EIs to ensure adjacent vegetation is preserved for the duration of construction activities. Where feasible, SDG&E will preserve vegetation within the defined work areas and leave root systems intact during construction activities associated with each Project component.

4.0.1 Waterbars

Waterbars (i.e., slope breakers, diversion berms, rolling dips, and earthen dikes) are intended to reduce the slope length and divert run-on and runoff from Project work areas (e.g., access roads, staging yards, etc.) to adjacent stable areas. If installed properly, waterbars are one of the most effective ways to reduce erosion during construction. Table 2: Maximum Waterbar Spacing provides guidelines for waterbar spacing; however, actual spacing will depend on suitable outlets that are available. The location of waterbars and diversion swales will be identified by SDG&E’s designated QSP, who will stake the uphill and downhill ends of the diversion feature prior to installation so that the outslope can be verified. Waterbar gradients will range between two and eight percent to ensure a favorable outflow is achieved.

Table 2: Maximum Waterbar Spacing

Slope Steepness	Diversion Spacing (feet)
< 5%	Not required
5%	125
10%	80
15%	60
> 25%	50

Source: SDG&E 2010

Waterbars will serve to mitigate erosion along access roads during construction and maintenance procedures where rilling and downstream sedimentation is observed. Suitable outlets for waterbars include vegetated areas that are not susceptible to erosion, and velocity dissipation devices may be required to protect adjacent properties and prevent downstream sedimentation. Velocity dissipation devices are further discussed in Section 4.0.2 Velocity Dissipation Devices.

When required for access to work areas, swale or drainage crossing sites will be selected at right angles to minimize impacts to the natural water flow and drainage patterns. Additionally, drainage crossings will be avoided during periods of stormflow to avoid downstream sedimentation. All stream or wetland crossings will adhere to the requirements dictated under the applicable resource agency permits, which include, but are not limited to, the following:

- the California Department of Fish and Wildlife (CDFW) Fish and Game Code Section 1602 Streambed Alteration Agreement,
- the Clean Water Act (CWA) Section 404 Nationwide Permits issued by the U.S. Army Corps of Engineers, and
- the CWA Section 401 Water Quality Certifications issued by the Regional Water Quality Control Board (RWQCB).

Waterbars will serve to mitigate erosion along access roads during construction and maintenance procedures where rilling and downstream sedimentation is observed. Suitable outlets for waterbars include vegetated areas that are not susceptible to erosion, and velocity dissipation devices may be required to protect adjacent properties and prevent downstream sedimentation. Velocity dissipation devices are further discussed in Section 4.0.2 Velocity Dissipation Devices.

When required for access to work areas, swale or drainage crossing sites will be selected at right angles to minimize impacts to the natural water flow and drainage patterns. Additionally, drainage crossings will be avoided during periods of stormflow to avoid downstream sedimentation. All stream or wetland crossings will adhere to the requirements dictated under the applicable resource agency permits, which include, but are not limited to, the following:

- the California Department of Fish and Wildlife (CDFW) Fish and Game Code Section 1602 Streambed Alteration Agreement,
- the Clean Water Act (CWA) Section 404 Nationwide Permits issued by the U.S. Army Corps of Engineers, and
- the CWA Section 401 Water Quality Certifications issued by the Regional Water Quality Control Board (RWQCB).

4.0.2 Velocity Dissipation Devices

Velocity dissipation devices composed of rock or riprap may be required to prevent scour and erosion caused by concentrated, high-velocity flows at existing culverts, channels, or constructed waterbars. Generally, the size to control flow velocity is based on the evaluation of erosion risk, soil types, and site-specific flow patterns and rock apron lengths. The size of rock placed will be determined based on estimated discharge rates. Rock apron lengths for flows conveyed in open channels (e.g., ditches, swales, or along waterbars) are detailed in Table 3: Discharge Rate, Apron Length and Rock Diameter. Filter fabric will be placed underneath the rock or riprap apron to prevent scour.

Inspection of velocity dissipation devices and implementation of corrective actions in accordance with CGP requirements, as described in Section 4.1.0 Erosion Control Inspection and Maintenance Requirements, will ensure that the dissipation devices are functioning as intended and that downstream resources are protected from erosion and sedimentation.

Table 3: Discharge Rate, Apron Length and Rock Diameter

Approximate Discharge Rate (feet/second)	Approximate Apron Length (feet³/second)	Minimum Riprap D₅₀ Diameter (inches)
5	10	4
10	10 to 13	6 to 8
20	16	8 to 12
30	16 to 23	8 to 16
40	26	8 to 16
50	26	16
60	30	8

Source: SDG&E 2010

Armoring of stream channels is not anticipated during construction of the Project. However, if the installation of temporary low-water crossings or hardening of stream crossing bottoms or approaches is required to protect downstream resources, no work will be conducted without a permit or authorization from the applicable resource agency (i.e., the CDFW, USACE, and RWQCB).

4.0.3 Fiber Rolls

A fiber roll (i.e., straw wattle) consists of straw, flax, or other similar materials that are bound into a roll. The fiber roll lets water through, but prevents the majority of sediment from passing through. Additionally, fiber rolls placed perpendicular to slopes reduce erosion by intercepting and slowing the flow of runoff. Only certified weed-free and seed-free rice straw will be used for fiber rolls to avoid the spread of non-native seed. Fiber roll manufacturer information must be acquired by the Qualified SWPPP Developer (QSD) prior to use on the Project. Fiber rolls will be installed on the Project along steep slopes and/or adjacent to jurisdictional waterways. The fiber rolls will generally be spaced between 10 and 20 feet apart, as detailed in Table 4: Fiber Roll Spacing for Slope Application.

Table 4: Fiber Roll Spacing for Slope Application

Slope Grade	Spacing (not-to-exceed sheet flow length)
0 to 25 percent	20 feet
25 to 50 percent	15 feet
> 50 percent	10 feet

Source: SDG&E 2010

Fiber rolls may be required at stringing sites, pole work areas, and where ground disturbance occurs in association with trenching or undergrounding activities. Additionally, they will be installed prior to seeding efforts and hydraulic mulch application, where rilling has been observed; and prior to the installation of temporary erosion control matting on graded or disturbed slopes of 10 feet or greater.

4.0.4 Erosion Control Matting

Erosion control matting or fabric (e.g., rolled erosion control products) is a loosely woven burlap-type material or other biodegradable plant fiber (e.g., coconut fiber). Jute matting and/or other approved erosion control matting prescribed by the QSD/QSP will be used on the Project where rolled erosion control products are deemed necessary to control erosion. Generally, jute matting will be installed on slopes greater than 30 percent, and after the area has been track-walked and after waterbars and straw wattles have been installed. Jute matting applications for erosion control will ultimately be determined in the field by the QSD/QSP based on site conditions. The matting will be properly anchored in all areas and tightly fitted around straw wattles and waterbars to ensure ground contact. Jute matting will serve to protect exposed soil from wind and rain, and will reduce the speed at which water moves across the soil surface, primarily along moderate to steep slopes where access and stabilization are difficult. Applications of jute matting on the Project may also include installation on disturbed slopes associated with access routes, staging areas, stringing sites, pole work areas, or trenching activities. Jute matting will be utilized to stabilize disturbed channel bottoms or erosional features adjacent to waterways. Jute matting within channel bottoms will serve to retain seed and prevent erosion during periods of storm flow. Matting must be anchored with soil staples or geotextile pins, and the upstream extent of the matting must be keyed into the stream bed and banks to ensure the matting remains intact during periods of storm flow.

Following seed application along slopes greater than 30 percent or within temporarily disturbed drainages, jute matting will be installed as deemed necessary by the Project QSD/QSP or Habitat Restoration Specialist (HRS), based on site conditions and the potential for concentrated runoff.⁴

4.0.5 Hydraulic Mulch and Seeding

Hydraulic mulch can be used to reduce soil erosion during precipitation events by intercepting the impact of raindrops on areas with disturbed soils. Prior to vegetation establishment, hydraulic mulching serves to reduce soil erosion, regulate soil temperatures, and protect seed from wildlife and wind. Hydraulic mulch application may be used in conjunction with acrylic polymers or soil amendments to ensure soil stabilization. Hydraulic mulch application rates will be site-specific, based on the manufacturer's recommendations, and verified by the Project QSD/QSP prior to application.

Hydraulic mulch in conjunction with hydroseed application will be applied to disturbance areas that are larger than 0.10 acre to achieve post-construction stabilization. As a temporary erosion control measure, hydraulic mulch will be applied to disturbed slopes associated with trenching activities and stringing sites, as well as soil stockpiles, prior to anticipated storm events to satisfy CGP requirements during construction. In support of long-term stabilization efforts, hydraulic mulch will be applied in conjunction with hydroseed application, or after seed has been applied and achieved soil contact.

Hydraulic mulch and seeding applications may include disturbance areas less than 0.10 acre that are within or in close proximity to Riparian Conservation Areas (RCAs) or watercourses. As discussed in Section 4.1 SWPPP Implementation and Erosion Control Inspection During

⁴ Habitat enhancement activities will occur under the direction of an HRS, as further described in the Project HRP.

Construction, BMP site maps contained within the SWPPPs for the Project depict the location of watercourses and sensitive habitats, including RCAs. Disturbance areas within or adjacent to these resources will be evaluated by the QSD, and BMP site maps will reflect all disturbance areas that require hydraulic mulch and seeding.

4.0.6 Wind Erosion Control

Wind erosion control consists of applying water to prevent or alleviate fugitive dust generated by ground disturbance or construction-related traffic. USFS Handbook BMPs for road management specifically require road surface treatment to stabilize road beds, reduce dust, and control soil erosion. Soil covers, plastic sheeting, and erosion control matting may also satisfy dust control and local air quality requirements with regard to soil stockpiles and pole work areas on the Project. SDG&E will limit the use of plastic materials when more sustainable, environmentally friendly alternatives exist, in accordance with the CGP. Water applied for dust control will be applied evenly and in a manner that does not generate runoff. Wind erosion controls will be implemented during construction of all Project components to prevent fugitive dust.

4.1 SWPPP IMPLEMENTATION AND EROSION CONTROL INSPECTION DURING CONSTRUCTION

Erosion control methods included in this ECP support Project compliance with the CGP. As required by the CGP, SDG&E will develop a SWPPP for the Project to address construction storm water pollutants, and will incorporate the erosion control methods included in this ECP. Due to the phased construction schedule of the Project and the geographical distance between Project components, multiple site-specific SWPPPs will be developed where two or more individual construction segments are grouped.

Prior to construction, CGP coverage for the Project will be obtained through submittal of Permit Registration Documents to the SWRCB's SMARTS. CGP coverage will be effective once a Waste Discharge Identification number is issued by SMARTS.

BMPs will be implemented in accordance with the SWPPP to prevent erosion and minimize sedimentation prior to construction, and will be maintained in accordance with the SWPPP and relevant USFS and SDG&E guidance. Construction BMP site maps depicting the locations of erosion controls to be implemented for each Project segment will be incorporated into the SWPPP and are included in Attachment D: SWPPP BMP Site Maps. As construction on the Project progresses, this ECP will be updated to include a construction BMP site map for each segment proposed for construction and CGP coverage. The updated ECP will be provided to the CPUC and USFS for review and approval prior to each agency's NTP issuance for each construction segment.

Construction BMP site maps depict the following elements as they relate to this ECP:

- construction site boundaries;
- the location of all soil-disturbing activities;
- the location of drainage areas, watercourses, drainage structures, and sensitive habitats;
- storm water discharge locations;
- sampling locations, as applicable; and

- the location and type of proposed erosion controls to be installed.

The implementation of erosion control devices during construction will be dictated by the designated QSD or QSP for the Project.

4.1.0 Erosion Control Inspection and Maintenance Requirements

All erosion controls will be inspected and maintained during construction in accordance with Attachment A: Linear Underground/Overhead Requirements of the CGP.⁵ Each site-specific SWPPP will include a proposed schedule for erosion control implementation and maintenance, inspection requirements, and a Monitoring and Reporting Program. Implementation of the Monitoring and Reporting Program for each Project segment will be determined by CGP risk type.⁶ Visual inspections and sampling collection will be conducted in accordance with the CGP, as noted in Table 5: CGP Inspection Requirements for Linear Underground/Overhead Projects. Visual inspections will serve to identify and record erosion control BMPs that require maintenance to operate effectively or that have failed, or identify corrective actions necessary for the erosion control devices to operate as intended. The designated QSD/QSP or trained EI will complete inspection checklists to document site conditions before, during, and after rain events, and as required by Attachment A: Linear Underground/Overhead Requirements of the CGP. Site inspection and visual observation forms will be maintained by the QSD within each site-specific SWPPP for the Project.

Table 5: CGP Inspection Requirements for Linear Underground/Overhead Projects

LUP Type	Visual Inspections				Sample Collection		
	Daily Site BMP	Pre-Storm	Daily Storm	Post-Storm	Storm Water Discharge	Receiving Water	Non-Visible (when applicable)
1	X						X
2	X	X	X	X	X		X
3	X	X	X	X	X	X	X

⁵ Attachment A: Linear Underground/Overhead Requirements of the CGP regulates all construction activities from linear underground/overhead projects (LUPs). LUPs include, but are not limited to, any conveyance, pipe, or pipeline for the transportation of any gaseous, liquid (including water and wastewater for domestic municipal services), liquescent, or slurry substance; any cable line or wire for the transmission of electrical energy; any cable line or wire for communications (e.g., telephone, telegraph, radio or television messages); and associated ancillary facilities.

⁶ Attachment A: Linear Underground/Overhead Requirements of the CGP establishes three types (i.e., Types 1, 2, and 3) of complexity for areas within an LUP or project section based on the threat to water quality. The project area or project types are determined through Attachment A.1 of the CGP.

4.2 POST-CONSTRUCTION LONG-TERM STABILIZATION

Post-construction long-term stabilization of Project work areas will be achieved through implementation of the ECP and the HRP, and will satisfy post-construction stabilization requirements, as described by the CGP and the applicable resource agency permits.

Following replacement pole installation and line reconductoring, all temporarily disturbed Project areas will be restored to pre-construction conditions, or equivalent to unscathed areas adjacent to the work area if erosional features were observed prior to Project activities. As discussed in Section 4.0 Erosion Control Methods, structural erosion controls and non-structural erosion controls will support long-term stabilization efforts. Post-construction erosion controls and revegetation will assist in satisfying final stabilization requirements under the CGP for each Project segment. CGP coverage for the Project will be terminated once a Notice of Termination is filed and approved by the San Diego RWQCB.

A primary goal of long-term stabilization and restoration is to prevent off-site sedimentation by controlling erosion. However, until disturbed Project areas become stabilized through revegetation, sediment controls may be necessary to prevent sediment transport off Project work areas. In general, sediment control (e.g., silt fence and fiber rolls) will be installed where there is the potential for sediment to be deposited in waterbodies or sensitive resource areas. The location of sediment barriers along each Project segment will be determined by SDG&E's designated QSP for the Project and in accordance with each respective SWPPP.

4.2.0 Decompaction

Soil compaction can increase surface runoff, reduce the water-holding capacity, and increase the potential for wind erosion and seed loss. Prior to initiating final grading, the construction contractor and the HRS will coordinate to determine if soil decompaction is necessary by comparing the work area to adjacent, non-disturbed areas. The use of a penetrometer, per the manufacturer's specifications, will be required to assess soil compaction. If necessary, decompaction will be performed with a deep-tillage instrument, the teeth of a backhoe bucket, a bulldozer ripper, or a similar method prior to re-spreading topsoil. The preferred decompaction method will be determined by the HRS based on penetrometer readings and the confines of the work area. In some cases where compaction is only on the surface, scarifying during seedbed preparation will be sufficient.⁷

4.2.1 Revegetation

Revegetation of Project work areas will be conducted in accordance with the Project's HRP. The HRP promotes long-term stabilization of Project work areas and specifically describes the measures that will be taken by SDG&E and its contractors to ensure that areas affected by ground disturbance during Project construction are restored to near pre-construction conditions, or equivalent to unscathed areas adjacent to the affected area if erosional features were observed prior to Project activities.

⁷ Scarification is the process of loosening the surface layer. The process improves soil-to-seed contact and permeability, and facilitates seed cover when the soil is back-dragged after the seed is applied.

Revegetation efforts will be implemented once construction activities have been completed at any given Project work area or when an entire segment has been completed. In some cases, when completion of a Project component occurs outside of the recommended planting season, it may be necessary to implement temporary soil stabilization (e.g., application of a soil tackifier, hydromulch, an erosion control seed mix, etc.) until the planting season begins. Appropriate seed mixes approved for use on USFS-administered lands and application techniques are identified within the Project's HRP, and application will be conducted under the supervision of the designated HRS.

Several factors affect the end of the site preparation period and the commencement of seeding, including forecasted rainfall throughout the year, the site's response to weed control strategies, and observations of vegetation growth. Seeding will generally occur in mid-November through mid-January to maximize natural rainfall patterns that occur within the Project area. Additionally, interim seeding may be deemed advantageous by the Project's QSD/QSP to prevent erosion and satisfy CGP requirements.

4.2.2 Revegetation Maintenance and Monitoring

After initial revegetation has been completed, the HRS will monitor the restoration effort as it relates to post-construction stabilization and restoration of temporary work areas. In accordance with the HRP,⁸ the HRS will collect pertinent information through direct observation during annual site visits, including data on germination success, plant density, survivorship, and diversity. Post-construction monitoring of all restored temporary work areas will ensure that restoration efforts meet the success criteria described in the HRP.

Site maintenance visits will occur on a semi-annual basis for up to four consecutive years and as deemed necessary by the HRS. Maintenance visits will occur once in the fall and spring of each monitoring year. Additional maintenance visits may be conducted throughout the year by SDG&E's maintenance contractor, if needed. As recommended by the HRS, maintenance activities will include weed treatment, maintenance of post-construction erosion controls, remedial seeding, or other requirements needed to facilitate post-construction stabilization and meet success standards contained within the HRP. Per the HRP, it is anticipated that maintenance visits will occur for five years following the implementation of revegetation efforts.

4.3 POST-CONSTRUCTION OPERATION AND MAINTENANCE PROCEDURES

Following Project construction, SDG&E will conduct operation and maintenance activities consistent with SDG&E's existing protocols and procedures, including SDG&E's Subregional NCCP. SDG&E will continue to regularly inspect, maintain, and repair the transmission lines once Project construction is complete. Schedule details specific to the inspection and maintenance of roads and drainage control features (e.g., waterbars and velocity dissipation devices) on USFS lands will be described in the SDG&E Operations and Maintenance Plan (O&M Plan) on National Forest Service Lands⁹ and will be managed under the Master Special

⁸ Revegetation maintenance and monitoring protocols included in this ECP are subject to final approval of the HRP.

⁹ An O&M Plan is currently in development.

Use Permit. The O&M Plan will also discuss corrective actions that may be required when BMPs fail and will include a timeline for completing identified corrective actions.

SDG&E maintains a working space that is at least 10 feet in diameter around all steel poles, and these areas are kept clear of shrubs and other obstructions for inspection and maintenance purposes. In addition, vegetation that has a mature height of at least 15 feet is not allowed to grow within 10 horizontal feet of any conductor for safety and reliability reasons. Clearing operations associated with operation and maintenance procedures will not affect long-term stabilization of the Project work areas.

Road maintenance and operations on National Forest System lands will be consistent with USFS BMP 2.4 – Road Maintenance and Operations, contained within the USFS Handbook and applicable USFS National Core BMPs. SDG&E Transmission Construction and Maintenance crews grade road surfaces on a routine basis (bi-annually) to ensure adequate access to electric transmission structures. Continual maintenance of access roads will be conducted in accordance with all federal and state water quality laws and regulations.

5 – REFERENCES

- Dudek. 2015. Environmental Impact Report/Environmental Impact Statement and Master Special Use Permit and Permit to Construct Power Line Replacement Projects. Online. <http://www.cpuc.ca.gov/environment/info/dudek/CNF/Final-EIR-EIS.htm>. Site visited October 2015.
- Insignia Environmental. 2015. Habitat Restoration Plan for the San Diego Gas & Electric Company Master Special Use Permit and Permit to Construct Power Line Replacement Projects.
- SDG&E. 1995. Subregional Natural Community Conservation Plan.
- SDG&E. 2010. Best Management Practices and Drainage Control Guidance Manual for Maintenance Roads.
- SDG&E. 2011. Best Management Practices Manual for Water Quality Construction.
- USFS. 2000. Water Quality Management for Forest System Lands in California Best Management Practices.
- USFS. 2011. Forest Service Hand Book Southwest Region (Region 5) Vallejo, CA. R5 FSH 2509.22 – Soil and Water Conservation Handbook Chapter 10-Water Quality Management Handbook, Amendment Number 2509.22-2011-1.
- USFS. 2012. National Best Management Practices for Water Quality Management on National Forest System Lands. Volume 1: National Core BMP Technical Guide.
- USFS. 2014. Restoration of Forests, Grasslands, and Wetlands Damaged by Off-Highway Vehicles.

USFS. 2015. Cleveland National Forest. Online.
<http://www.fs.usda.gov/detail/cleveland/landmanagement/planning>. Site visited October 2015.

**ATTACHMENT A: USFS SOIL AND WATER CONSERVATION HANDBOOK EROSION
CONTROL BMPS**



**FOREST SERVICE HANDBOOK
SOUTHWEST REGION (REGION 5)
VALLEJO, CA**

R5 FSH 2509.22 - SOIL AND WATER CONSERVATION HANDBOOK

CHAPTER 10 - WATER QUALITY MANAGEMENT HANDBOOK

Amendment No.: 2509.22-2011-1

Effective Date: December 5, 2011

Duration: This amendment expires 5 years from the effective date unless superseded or remove earlier.

Approved: RANDY MOORE
Regional Forester

Date Approved: 12/5/2011

Posting Instructions: Amendments are numbered consecutively by Handbook number and calendar year. Post by document; remove the entire document and replace it with this amendment. Retain this transmittal as the first page(s) of this document. The last amendment to this Handbook was 2509.22-2 (7/16/1990) to chapter 50.

New Document 2509.22_10 237 Pages

**Superseded Document(s)
by Issuance Number and
Effective Date** None

Digest:

New issuance.

**R5 FSH 2509.22 - SOIL AND WATER CONSERVATION HANDBOOK
CHAPTER 10 - WATER QUALITY MANAGEMENT HANDBOOK**

12.21 Exhibit 04

BMP 2.4 - Road Maintenance and Operations

Objective: To ensure water-quality protection by providing adequate and appropriate maintenance and by controlling road use and operations.

Explanation: Appropriate maintenance and control of road use and operations can protect water quality, aquatic and riparian resources, and capital investments. Maintenance needs and operational controls are informed by periodic inventory and assessment that determine road condition and the potential impacts the road has on water quality.

Properly designed and maintained road surfaces and drainage systems can reduce adverse effects to water resources by facilitating natural hydrologic function. Roads and drainage systems normally deteriorate because of traffic, weather, and effects of maintenance. In addition, roads occasionally become saturated by new groundwater springs and seeps after a wildfire or unusually wet periods. Many such conditions can be corrected by timely maintenance. However, while routine maintenance may be needed to ensure the road performs as designed, it can also be a source of soil disturbance and therefore, sediment production. In particular, the grading of inside ditches and road surfaces can significantly increase sediment production rates. Less aggressive maintenance may be desired to minimize disturbance of stable sites.

Road management objectives include the level and type of maintenance that a road is expected to receive. Assigned road maintenance levels vary from 1 to 5, and are directly linked to the operational objectives for the road. Maintenance Level 1 is assigned to roads closed to all motorized vehicles for a year or more; they should be left in a stable condition, and by definition, require less maintenance. Maintenance Levels 4 and 5 are assigned to roads that are typically double-lane, aggregate-surfaced or paved, and passenger vehicle traffic is "encouraged." They are well maintained to provide a moderate to high degree of user comfort and convenience.

Operational objectives and activities are also defined by the road management objectives, and depend upon the amount of maintenance a road is expected to receive. Road operations also include permit, contract, and agreement administration, control of seasonal use, sustaining roads in closed status and revising maintenance levels and seasonal closures, as needed. Road closures and restrictions are necessary because many forest roads are designed for dry-season use. Most local roads are not surfaced, while others have some surfacing or spot stabilization. Roads without stabilized surfaces or adequate base can be damaged by use during wet periods or by loads heavier than the road was designed to convey.

Road maintenance plans are implemented through contract, cooperators, force account, and active timber sale or other authorized activities. Contract, timber sale, and other authorized or permitted operations are bound by specifications and drawings. BMPs are incorporated as specifications, contract or sale clauses, operating plan requirements, permit clauses, and are often

**R5 FSH 2509.22 - SOIL AND WATER CONSERVATION HANDBOOK
CHAPTER 10 - WATER QUALITY MANAGEMENT HANDBOOK**

12.21 Exhibit 04 -- Continued
BMP 2.4 - Road Maintenance and Operations

shown in the drawings. The contracting officer's representative is responsible for assuring compliance by contractors; engineering representative, TSA, or FSR assures compliance by cooperators, purchaser or permitted operator. Project manager and crew supervisor assures compliance for force account work. Optimally, the forest hydrologist works with the forest quality assurance personnel to determine if approved maintenance tasks are completed with minimal resource impacts. Adjustments to future maintenance plans and methods are considered when previous methods do not provide the needed protection to water quality.

Risk from road maintenance activities can be managed by using the appropriate techniques from the following list adapted as needed to local site conditions.

Implementation

Inspection:

1. Periodically inspect system travel routes to assess condition and linkage to water quality. This information assists in setting maintenance and improvement priorities.
 - a. Provide training to the engineering personnel performing condition surveys to successfully identify and assess linkage to water quality.
 - b. Conduct condition surveys jointly with engineering and hydrology personnel, to more accurately assess potential of road to impact water quality.
 - c. Prioritize inspections to roads at high risk of failure, followed by road segments that are hydrologically connected to the stream network, to reduce risk of diversions and cascading failures.
 - d. Identify diversion potential on roads, and prioritize for treatment.
2. Inspect drainage structures and runoff patterns after major storm events and snowmelt, and perform any necessary maintenance. Major storm events include all storm events for which the National Weather Service issues a local flood watch, advisory, or warning.
 - a. Determine the extent of hydrologic connectivity during and/or just after major storm events, including the connectivity of disturbed areas directly adjacent to the road network. Use this information to prioritize and plan improvements to road drainage.
 - b. Immediately clean out, repair or reconstruct waterbars, inside ditches, culverts, and other features that are not functioning in order to hydrologically disconnect roads

**R5 FSH 2509.22 - SOIL AND WATER CONSERVATION HANDBOOK
CHAPTER 10 - WATER QUALITY MANAGEMENT HANDBOOK**

12.21 Exhibit 04 -- Continued
BMP 2.4 - Road Maintenance and Operations

- from surface waters and prevent discharges of sediment and other pollutants to water bodies.
3. Regularly inspect roads during all operations.
 4. Keep roads closed to public use, but open for administrative use, in hydrologically functional condition. If waterbars are breached, forest personnel will promptly repair them.
 5. Encourage field personnel of all disciplines to observe road deterioration or damage commensurate with travel to field activities, and report to engineering, for immediate action, if necessary.
 - a. Restrict operations if impact or imminent threat of impact to water quality is occurring.
 - b. Consider restricting operations if road damage such as surface displacement or active rutting is occurring.

Maintenance Planning:

1. Incorporate the forest's Wet Weather Operations Standards and notification protocols in maintenance and operations.
2. Develop and implement an erosion control plan commensurate with the complexity and scale, and duration of the activity. See BMP 2.13.
3. Develop and implement annual maintenance plans that prioritize road maintenance work for the forest or district.
 - a. Include roads identified as needing maintenance from field condition surveys, and roads identified through roads analysis and travel analysis that negatively impact water quality.
 - b. Determine method of accomplishment (contract, force account, permit, and cooperative) and define responsibilities and maintenance timing in the plan.
4. Planning for emergency interim/temporary erosion controls to protect water quality is considered for roads that may require immediate maintenance, but are beyond capability of annual maintenance plan.

**R5 FSH 2509.22 - SOIL AND WATER CONSERVATION HANDBOOK
CHAPTER 10 - WATER QUALITY MANAGEMENT HANDBOOK**

12.21 Exhibit 04 -- Continued
BMP 2.4 - Road Maintenance and Operations

5. Identify roads with potential to improve water quality by modifying road prism and drainage patterns through maintenance operations.
 - a. Analyze roads in an interdisciplinary manner to identify other impacts that may occur due to changes in road prism or drainage patterns. Consider local conditions and site characteristics.
 - b. Implement diversion potential method per Forest Service Publication 9777.1814P-SDTDC Diversion Potential at Road-Stream Crossings.
 - c. Consider user safety and protection of other forest resources.
 - d. Provide training and reference materials for forest road managers, road maintenance operators, and road maintenance contract preparation personnel to work with hydrologists in identifying appropriate roads for revised maintenance procedures.
6. Evaluate road management objectives when an inspection indicates road design is not meeting current transportation and/or resource needs. Road management objectives support forest LRMP prescriptions.

Maintenance Activities:

1. Maintain road surfaces to dissipate intercepted water in a uniform manner along the road by outsloping with rolling dips, insloping with drains, or crowning with drains. Where feasible and consistent with protecting public safety, utilize outsloping and rolling the grade (rolling dips) as the primary drainage technique.
2. Adjust surface drainage structures to minimize hydrologic connectivity by:
 - a. Discharging road runoff to areas of high infiltration and high surface roughness.
 - b. Armoring drainage facility outlet as energy dissipater and to prevent gully initiation.
 - c. Increasing the number drainage facilities with SMZs.
3. Clean ditches and drainage structure inlets only as often as needed to keep them functioning. Prevent unnecessary or excessive vegetation disturbance and removal on features such as swales, ditches, shoulders, and cut and fill slopes.
4. Minimize diversion potential by installing diversion prevention dips that can accommodate overtopping runoff.

**R5 FSH 2509.22 - SOIL AND WATER CONSERVATION HANDBOOK
CHAPTER 10 - WATER QUALITY MANAGEMENT HANDBOOK**

12.21 Exhibit 04 -- Continued
BMP 2.4 - Road Maintenance and Operations

- a. Place diversion prevention dips downslope of crossing, rather than directly over the crossing fill, and in a location that minimizes fill loss in the event of overtopping.
 - b. Armor diversion prevention dips when the expected volume of fill loss is significant.
5. Address risk and consequence of future failure at the site when repairing road failures. Use vegetation, rock, and other native materials to help stabilize failure zones.
 6. Maintain road surface drainage by removing berms, unless specifically designated otherwise.
 7. Install and preserve markers to identify and protect drainage structures that can be damaged during maintenance activities (that is, culverts, subdrains, and so forth)
 8. When grading roads or cleaning drainage structure inlets and ditches, avoid undercutting the toe of the cut slope.
 9. Grade road surfaces in accordance with road management objectives and assigned maintenance level. Grade only as needed to maintain a stable running surface and adequate surface drainage.
 10. Accompany grading of hydrologically connected road surfaces and inside ditches with erosion and sediment control installation.
 11. Identify additional road maintenance measures to protect and maintain water; aquatic, and riparian resources including: surfacing and resurfacing, outsloping, dips and cross drains, armoring of ditches, spot rocking, replacing culverts, and installing new drainage features.
 12. Effectively maintain roads in storage to eliminate all motorized vehicle use. Maintain physical closure devices, if present, to be safe and effective. For roads where physical closure methods are not feasible, install signing to inform of road closure.
 13. Enforce pre-haul maintenance, maintenance during haul, and post haul maintenance (putting the road back in storage) specifications when maintenance level 1 roads are opened for use on commercial resource management projects. Require the commercial operator to leave roads in a satisfactory condition when project is completed.
 14. Opened for use on commercial resource management projects. Require the commercial operator to leave roads in a satisfactory condition when project is completed.

**R5 FSH 2509.22 - SOIL AND WATER CONSERVATION HANDBOOK
CHAPTER 10 - WATER QUALITY MANAGEMENT HANDBOOK**

12.21 Exhibit 04 -- Continued
BMP 2.4 - Road Maintenance and Operations

Operations:

1. Restrict or prohibit road use during periods when such use would likely damage the roadway surface or road drainage features are identified through Travel Analysis and Travel Management, and implement through enforcement of motor vehicle use map. Changes in road management are supported by appropriate analysis. Follow the forest's WWOS. See BMP 2.13.
2. Require users to obtain permit(s) when proposed operations involve use of roads by vehicles larger than the design vehicle, or beyond typical operation period or season of use (that is, timber purchasers, mining operations, oversize vehicle movement, and so forth. Conditions of the permitted use may require:
 - a. Strengthening the road surface by adding rock, dust palliatives, pavement, or armor, particularly in areas where surfaces are vulnerable to movement such as corners and steep sections.
 - b. Considering short-term road surface stabilization by dust abatement methods, such as watering.
 - c. Upgrading drainage structures.
 - d. Restricting use to low-ground-pressure vehicles or frozen ground conditions.
 - e. Strengthening the road base if roads are tending to rut.
 - f. Using a base course of rock and/or geotextile fabric to provide subsurface stability.
 - g. Intensifying maintenance to handle the traffic without creating excessive erosion and damage to the road surface.
 - h. Repairing damage to road and forest resources associated with use by permittee.
 - i. Restoring the road to original standard of features, such as restoring waterbars.
3. To the extent possible, ensure drainage features are fully capable of preventing pollutant discharges to surface waters before the start of the local winter season (such as November 16 to March 31) or before the start of runoff-inducing precipitation events.

**R5 FSH 2509.22 - SOIL AND WATER CONSERVATION HANDBOOK
CHAPTER 10 - WATER QUALITY MANAGEMENT HANDBOOK**

4. Permits to oversize or overweight loads require that damage by such loads be repaired by the permit holder. Damage includes impacts to water quality.
5. Cooperative maintenance agreements follow Forest Service direction for use, maintenance, repairs, and responsibilities.
6. Roads under easement are subject to terms of conditions for operation and maintenance.

**R5 FSH 2509.22 - SOIL AND WATER CONSERVATION HANDBOOK
CHAPTER 10 - WATER QUALITY MANAGEMENT HANDBOOK**

12.21 Exhibit 13
BMP 2.13 - Erosion Control Plan

Objective: Effectively limit and mitigate erosion and sedimentation from any ground-disturbing activities, through planning prior to commencement of project activity, and through project management and administration during project implementation.

1. Provide seamless transition between planning-level (NEPA) mitigation descriptions and on-the-ground implementation of erosion-control measures tailored to site conditions.
2. Ensure that all disturbance-related mitigation requirements and provisions for field revisions or modifications are accurately captured in one comprehensive document for each project or activity.
3. Activities include, but are not limited to: timber sale harvest; facility site, road, bridge, trail and appurtenance construction, reconstruction, and maintenance; watershed improvement; road and trail decommissioning; legacy site restoration, administratively permitted activities; and vegetation and fuels management activities.
4. Comply with overarching area plans, such as Northwest Forest Plan and Sierra Nevada Framework Plan Amendment.

Explanation: Ground-disturbing activities can result in erosion and sedimentation. By effectively planning for erosion control, sedimentation can be controlled or prevented. Engineering and hydrology personnel jointly develop mitigation recommendations and preliminary BMPs using an interdisciplinary team during the project planning process and environmental analysis phase. Erosion control plans are not to be confused with design features whose primary objective is to provide or improve water quality, such as a bridge; reinforced earth retaining wall; or landscaping. The long-term mitigation objectives are typically described in the NEPA document for the project, and then refined in project drawings and specifications as design features. Short-term mitigation measures to prevent erosion and sedimentation are described in detail in the project's erosion control plan.

Project mitigations are conceptually described in NEPA analyses but are typically generic. Detailed mitigation measures are based on site-specific surveys, conditions, and characteristics, and are developed in the project design phase. They are ultimately displayed in the project document's design documents (specifications and drawings) based on site-specific surveys, conditions, and characteristics. Furthermore, field personnel have the responsibility to make refinements or additional recommendations to adjust to actual current and predicted future conditions.

**R5 FSH 2509.22 - SOIL AND WATER CONSERVATION HANDBOOK
CHAPTER 10 - WATER QUALITY MANAGEMENT HANDBOOK**

12.21 Exhibit 13 -- Continued
BMP 2.13 - Erosion Control Plan

This flexibility is a necessary and desirable component of project implementation, but must ultimately result in implementation of requirements to protect soil and water quality. To ensure that all required and relevant mitigation measures are documented and implemented, an environmental control plan will be prepared to complement design (design addresses required mitigations specified in NEPA documents), site-specific prescriptions, and amended to include changes made in the field. Detailed and accurate environmental control plan will allow Forest Service and Water Board staff to conduct efficient, meaningful inspections of ground-disturbing projects, and will provide a needed check to ensure that mitigation measures for addressing impacts from the activities are accurately communicated to field staff.

Implementation: Ground-disturbing activities will be exempt from the requirement to prepare an erosion control plan under any of the four exemption categories below:

1. Area-based - less than 50 square feet in riparian area; less than 10,000 square feet in a non-riparian area;
2. Activity-based - activities conducted under a categorical exclusion with no wheeled or tracked equipment, or included under North Coast Regional or State waiver Category A;
3. Site-condition criteria - project locations that are: outside of riparian areas and on soils with high infiltration rates (more than 2 inches per hour) and on slopes less than 15 percent.
4. Flexibility criteria - any activity approved by the forest hydrologist with documentation explaining the rationale for the exemption.

BMP checklists will be prepared for all projects (see section 16) even if an erosion control plan is not necessary.

Erosion control plans for any ground-disturbing activity not meeting the exemption categories above will be reviewed and recommended by the forest hydrologist, and approved and signed by the District Ranger. The hydrologist's recommendation and signature indicates that all mitigation measures prescribed in environmental documents and project plans, or resource specialist's recommendations are included on the environmental control plan. The Forest Supervisor will approve and sign the environmental control plan for forestwide ground-disturbing activities, such as annual road maintenance.

All forests shall develop wet weather operations standards (WWOS). The purpose of the WWOS is to provide guidance with the end result of preventing significant adverse impacts to water quality from wet weather operations on NFTS roads and trails. Such operations may include

**R5 FSH 2509.22 - SOIL AND WATER CONSERVATION HANDBOOK
CHAPTER 10 - WATER QUALITY MANAGEMENT HANDBOOK**

12.21 Exhibit 13 -- Continued
BMP 2.13 - Erosion Control Plan

winter hauling, fuelwood gathering, public access for hunting or Christmas tree cutting, administrative access on closed roads for springtime burning of slash piles, reforestation activities, snow plowing, or other ground disturbance outside normal operating season. WWOS must include notification protocols for informing resource specialists (hydrologists, biologists, soil scientists) as well as line officers prior to initiation or continuation of a project or activity into wet weather season.

Project field operations cannot begin until the District Ranger approves and signs the plan. The erosion control plan will be kept on site during project activity and made available for review upon request of a representative of the Water Board or any local storm water management agency which receives the storm water discharge. The erosion control plan shall be amended if there is a change in control practices, site conditions, or BMPs that may result in less water-quality protection than specified in the project's environmental document, project plan, accepted erosion control plan, or permit/waiver. The amendment must include: name of person requesting the change; a description of the change, including revised BMPs or control practices to mitigate the effects of the change; and why the change is needed.

Even the best erosion and sediment control plan cannot cover the specifics of each situation that will arise on a site during the life of a project. All parties involved in the project have a role and responsibility to ensure the activity complies with the goals or intent of the erosion control plan at all times. All temporary erosion and sediment control practices must be maintained and repaired as needed to assure continued performance of their intended function.

Erosion Control Plan Contents

1. Erosion and Sediment Control shall include:
 - a. List of anticipated ground-disturbing actions associated with the project (for example, stream diversion; exposed cut slopes; stripped and stockpiled topsoil; water source development or use)
 - b. Checklist which includes mitigation measures required by project NEPA, and in some cases CEQA documents, requirements to meet BMPs, project plans, specifications, and permits, if any. The selection of erosion and sedimentation control measures shall be based on assessments of site conditions and how storm events may contribute to erosion. Control measures will be selected from the references provided in the On-Line Library at the end of section 12, or will be of equivalent effectiveness as the measures described in those references.

**R5 FSH 2509.22 - SOIL AND WATER CONSERVATION HANDBOOK
CHAPTER 10 - WATER QUALITY MANAGEMENT HANDBOOK**

12.21 Exhibit 13 -- Continued
BMP 2.13 - Erosion Control Plan

- c. Illustrations of control practices designed to prevent erosion and sedimentation. Illustrations must show construction and installation details for control practices, and must be included in the erosion control plan. (for example, California Stormwater Quality Association BMP standard specifications CASQA at <http://www.cabmphandbooks.com>, or Caltrans Stormwater and Water Pollution Control guides at <http://www.dot.ca.gov/hq/construc/stormwater/stormwater1.htm>)
- d. Map/drawing(s) showing soil or water buffer zones, RCAs, RCHAs, SMZs or other soil or water protection areas to be protected from project activities. Project boundary extends beyond disturbance limits.
- e. A description of the color and/or pattern of flagging or marking for soil or water buffer zones, RCAs, RCHAs, SMZs or other soil or water protection areas for each unit.
- f. Relevant sections from the forest's WWOS that apply to activity/activities. The WWOS will provide guidance to prevent significant adverse impacts to water quality from wet weather operations on NFTS roads and trails.
- i. Forest motor vehicle use map will be used to determine seasonal closures for all NFTS routes that are not under permit or for administrative use only.
- (1) A storm preparedness plan that describes additional control practices to be implemented when the National Weather Service predicts a 50 percent or greater chance of precipitation.
- (2) A winterization plan that describes additional control practices to be implemented to stabilize the site during periods of seasonal inactivity. The dates vary by locality, and may be determined by the individual RWQCB (for example, October 15 through May 1). "Winterized" means that the site is stabilized to prevent soil movement permanently if project activities are complete, or temporarily in a manner which will remain effective until end of the stabilization period.
- (3) If winter activity, including over-snow operation is proposed, specifications for snow/ice depth or soil operability conditions must be described.
- g. Control practices to reduce the tracking of sediment onto paved roads. These roads will be inspected and cleaned as necessary.

**R5 FSH 2509.22 - SOIL AND WATER CONSERVATION HANDBOOK
CHAPTER 10 - WATER QUALITY MANAGEMENT HANDBOOK**

12.21 Exhibit 13 -- Continued
BMP 2.13 - Erosion Control Plan

- h. Control practices to reduce wind erosion and control dust.
 - i. A proposed sequential schedule to implement erosion and sediment control measures, in addition to the general construction schedule.
 - j. Location information, including directions to access the project area. Include a scaled map, with road names/numbers.
 - k. Contact information of project personnel, including name and cell phone number (that is, sale administrator, contracting officer's representative, project manager, project supervisor, contractor, site superintendent, hydrologist, permit administrator and so forth)
2. Maps requirements: Maps must be clear, legible, and of a scale such that depicted features are readily discernable. For example, sale area maps may be used to satisfy the mapping requirements outlined in b.ii, below, if they meet this intent.
- a. As a means of determining BMPs and erosion control measures, a topographic map should be in the project file. The map should extend beyond the boundaries of the project site, showing the project site boundaries, and surface and subsurface water bodies (ephemeral and intermittent waters, springs, wells, and wetlands) that could be at risk of water-quality impacts from project activities.
 - b. For timber harvest activities, unit-specific map(s) shall be scaled no smaller than 1 inch equals 1,000 feet (1:12,000). For all other activities, maps shall be scaled to provide legible interpretation of requirements shown above. All maps shall include:
 - (1) Specific locations of storm water structures and controls used during project activities.
 - (2) Erosion hazard ratings for each unit, specified down to 20 acres if different EHRs exist within each unit.
 - (3) Locations of existing and proposed haul roads, watercourse crossings, skid trails, and landings.
 - (4) Locations of post-project storm water structures and controls.
 - (5) Equipment access, storage, and service areas.

**R5 FSH 2509.22 - SOIL AND WATER CONSERVATION HANDBOOK
CHAPTER 10 - WATER QUALITY MANAGEMENT HANDBOOK**

12.21 Exhibit 13 -- Continued
BMP 2.13 - Erosion Control Plan

3. **Diversion of Live Streams:** If the project involves stream diversions for crossing construction, the erosion control plan must include detailed plans for these activities, including storm contingencies. See BMP 2.8 - Stream Crossings.
4. **Non-Storm Water Management:** The erosion control plan shall include provisions which eliminate or reduce the discharge of materials other than storm water to the storm sewer system and/or receiving waters. Such provisions shall ensure that discharged materials shall not have an adverse effect on receiving waters. Materials other than storm water that are discharged shall be listed, along with the estimated quantity of the discharged material.
5. **Waste Management and Disposal:** The erosion control plan shall describe waste management and disposal practices to be used at the project site. All wastes (including equipment and maintenance waste) removed from the site for disposal shall be disposed of in a manner that is in compliance with Federal, State, and local laws, regulations, and ordinances. Include plan for project-specific activities that produce waste products, such as concrete truck/chute/pump washout, equipment servicing, equipment washing, and so forth.
6. **Maintenance, Inspection, and Repair:** The erosion control plan shall include inspection, maintenance and repair procedures to ensure that all pollution-control devices identified in the erosion control plan are maintained in good and effective condition and are promptly repaired or restored. A qualified person shall be assigned the responsibility to conduct inspections. The name and telephone number of that person shall be listed in the erosion control plan. A tracking and follow-up procedure shall be described to ensure that all inspections are done by trained personnel and that adequate response and corrective actions have been taken in response to the inspection. This procedure may be in the form of a written checklist, with inspections signed and dated. Photo documentation is encouraged.
7. **Other Plans:** This erosion control plan may incorporate, by reference, the appropriate elements of other plans required by local, State, or Federal agencies. A copy of any requirements incorporated by reference shall be kept in the project file.
8. **Post-Project Storm Water Management:** The erosion control plan shall describe the storm water control structures and management practices that will be implemented to minimize pollutants in storm water discharges after project activity phases have been completed at the site. It shall also specify controls to be removed from the activity site(s) and methods for their removal. The discharger must consider site-specific factors and

**R5 FSH 2509.22 - SOIL AND WATER CONSERVATION HANDBOOK
CHAPTER 10 - WATER QUALITY MANAGEMENT HANDBOOK**

12.21 Exhibit 13 -- Continued
BMP 2.13 - Erosion Control Plan

seasonal conditions when designing the control practices that will function after the project is complete.

9. Preparer: The erosion control plan shall include the title and signature of the person responsible for preparation of the erosion control plan, the date of initial preparation, and the person and date responsible for any amendments to the erosion control plan.

10. Template: The Forest Service will develop sample templates for erosion control plans based on activity type. Complexity of the template will be commensurate with the degree of risk to impact water quality by the activity.

**R5 FSH 2509.22 - SOIL AND WATER CONSERVATION HANDBOOK
CHAPTER 10 - WATER QUALITY MANAGEMENT HANDBOOK**

12.5 - Vegetation Manipulation

Vegetation manipulation on NFS lands is conducted in the course of reforestation, brushland treatment for hazard reduction, brushland conversion to forest, fire or fuels treatment, forest health and range land improvement, and wildlife habitat improvement. The most common means of treatment are chemical, mechanical, burning, and biological (such as grazing). Program environmental impact statements covering these activities are the “Vegetation Management for Reforestation” and “Brushland Management” documents. Individual projects are, however, evaluated by an interdisciplinary team through the environmental analysis process.

The environmental analysis process is the mechanism whereby applicable Federal, State, and local water-quality laws are considered, as well as national, Regional, Forest, and District goals, objectives, management requirements, and management direction. The document specifies where, when, and in most cases, how management practices will be applied to meet project, administrative, and environmental objectives.

12.51 - Vegetation manipulation BMPs

- 5.1 Soil-disturbing Treatments on the Contour
- 5.2 Slope Limitations Mechanical Equipment Operation
- 5.3 Tractor Operation Limitation in Wetlands and Meadows
- 5.4 Revegetation of Surface-disturbed Areas
- 5.5 Disposal of Organic Debris
- 5.6 Soil Moisture Limitations for Tractor Operations
- 5.7 Pesticide Use Planning Process
- 5.8 Pesticide Application According to Label Directions and Applicable Legal Requirements
- 5.9 Pesticide Application Monitoring and Evaluation
- 5.10 Pesticide Spill Contingency Planning
- 5.11 Cleaning and Disposal of Pesticide Containers and Equipment
- 5.12 Streamside Wet Area Protection During Pesticide Spraying
- 5.13 Controlling Pesticide Drift During Spray Application

The following BMPs are for the control of nonpoint source pollution associated with vegetation manipulation activities. Each BMP was formulated based on the administrative directives that guide and direct the Forest Service to plan and implement vegetation management activities on NFS land.

The line officer on each administrative unit is responsible for fully implementing the Forest Service Manual, Handbooks, and directives that require water-quality protection and improvement during vegetation-manipulation activities. The directives provide details on methods to incorporate water-quality controls into each phase of the vegetation-manipulation program.

**R5 FSH 2509.22 - SOIL AND WATER CONSERVATION HANDBOOK
CHAPTER 10 - WATER QUALITY MANAGEMENT HANDBOOK**

Trained and qualified personnel will be available to assist the vegetation-manipulation work force to identify beneficial uses and the most recent state-of-the-art water-quality control methods and techniques, and to help evaluate results of BMP application.

Vegetation manipulation can involve activities such as road construction and use of heavy equipment. The BMPs for those types of activities are described in other sections of this text and are not repeated here. The appropriate BMPs for those activities must be implemented along with the following vegetation-manipulation BMPs.

**R5 FSH 2509.22 - SOIL AND WATER CONSERVATION HANDBOOK
CHAPTER 10 - WATER QUALITY MANAGEMENT HANDBOOK**

12.51 Exhibit 01

BMP 5.1 - Soil-disturbing Treatments on the Contour

Objective: To decrease sediment production and stream turbidity, while mechanically treating slopes.

Explanation: This is a preventive measure that limits surface-disturbance activities, such as, but not limited to, disking, seed drilling, and windrowing, to preclude water from concentrating by providing means of adequate infiltration and by decreasing the velocity of surface runoff so infiltration is enhanced. Due to mechanical limitation of the equipment, slopes greater than 30 percent are usually not considered for this type of treatment.

Factors evaluated are slope, infiltration rate, permeability, and water-holding capacity of the soil. Trained and qualified personnel make field evaluations of these factors as input to project planning. Implementation: Following NEPA procedures and using interdisciplinary team input, project planners will be responsible for formulating the appropriate contract provisions and/or mitigation measures for the contract, or project plans.

The project leader will be responsible for enforcing management requirements and mitigation measures that deal with soil-disturbing treatments through force account projects.

The contracting officer's representative will be responsible for enforcing provisions of the contract.

**R5 FSH 2509.22 - SOIL AND WATER CONSERVATION HANDBOOK
CHAPTER 10 - WATER QUALITY MANAGEMENT HANDBOOK**

12.51 Exhibit 02

BMP 5.2 - Slope Limitations for Mechanical Equipment Operation

Objective: To reduce gully and sheet erosion and associated sediment production by limiting tractor use.

Explanation: This is a preventive measure that limits excessive surface disturbance and keeps surface water from concentrating. This measure facilitates making allowances for proper drainage of disturbed areas by limiting tractor operation to slopes where corrective measures such as water bars can be effectively installed.

Criteria used to determine slope restrictions are onsite evaluations of soil stability, mass stability and geology, climate conditions, and soil water-holding capacity. These field determinations will be made as part of the environmental documentation process during project planning.

Implementation: Project planners will be responsible for ensuring that appropriate tractor operation provisions are included in the decision and activity-controlling documents. This practice will be implemented on vegetation-manipulation projects where determined to be appropriate by the interdisciplinary team.

The project leader will be responsible for applying management requirements and mitigation measures on site-specific areas, with the assistance of selected interdisciplinary team members.

The contracting officer's representative will be responsible for ensuring implementation of the contract provisions that pertain to tractor operation on steep slopes.

**R5 FSH 2509.22 - SOIL AND WATER CONSERVATION HANDBOOK
CHAPTER 10 - WATER QUALITY MANAGEMENT HANDBOOK**

12.51 Exhibit 03

BMP 5.3 - Tractor Operation Limitation in Wetlands and Meadows

Objective: To limit turbidity and sediment production resulting from compaction, rutting, runoff concentration, and subsequent erosion by excluding the use of mechanical equipment in wetland and meadows except for the purpose of restoring wetland and meadow function.

Explanation: This is a preventative practice designed to preclude the concentration of surface runoff and soil compaction, which can lead to rill and gully erosion with associated turbidity and sedimentation. This measure precludes, or reduces the need to take corrective measures to dissipate concentrated surface water runoff.

Target areas will be protected from mechanical operations except when trained and qualified interdisciplinary team personnel identify the areas for treatment. Specific protection measures will be established for each area that could incur adverse water-quality impacts (see also BMP 1.18).

Implementation: The application of this BMP will be mandatory on all vegetation-manipulation projects as prescribed in the environmental documentation.

Project planners will be responsible for including appropriate contract specifications and identifying management requirements and mitigation measures in the project decision and implementation documents.

The project leader will be responsible for identifying wet area and meadows not previously identified by the project planner during the implementation of Forest Service force account projects. The project leader will also be responsible for following project management requirements pertaining to wet areas and meadows.

On contracted projects, the contracting officer's representative will be responsible for identifying additional wet areas and meadows not previously identified by the project planners.

**R5 FSH 2509.22 - SOIL AND WATER CONSERVATION HANDBOOK
CHAPTER 10 - WATER QUALITY MANAGEMENT HANDBOOK**

12.51 Exhibit 04

BMP 5.4 - Revegetation of Surface-disturbed Areas

Objective: To protect water quality by minimizing soil erosion through the stabilizing influence of vegetation foliage and root network.

Explanation: This is a corrective practice to stabilize an otherwise unstable soil surface during vegetation-manipulation projects. The plant species selected will be a mix best suited for site conditions and attainment of multiple management objectives for the area. Native plant species will be used to the fullest extent feasible. Soil amendments and irrigation, along with application of mulch with tackifier, jute netting, or other supplement treatments may be necessary to ensure revegetation.

Grass or browse species will be seeded between previously planted trees where deemed appropriate for control of overland runoff, and to meet wildlife needs. The onsite factors evaluated include soil productivity, topography, EHR, soil water-holding capacity, target species, environmentally associated species, and climatic variables. Evaluation includes the collection of onsite data, and office interpretation by the interdisciplinary team (see also BMP 1.15).

Implementation: During the environmental documentation process, trained and qualified employees will assess the need for treatment, and prescribe the vegetative species mix for each project.

The project leader will implement the BMP on the project, under supervision of the responsible line officer.

**R5 FSH 2509.22 - SOIL AND WATER CONSERVATION HANDBOOK
CHAPTER 10 - WATER QUALITY MANAGEMENT HANDBOOK**

12.51 Exhibit 05

BMP 5.5 - Disposal of Organic Debris

Objective: To prevent gully and surface erosion with associated reduction in sediment production and turbidity during and after treatment.

Explanation: This is a preventive practice to reduce excessive volumes and velocities of overland flow, promote infiltration, and prevent wildfires from consuming excessive amounts of surface and soil organic matter and creating hydrophobic soil conditions.

The interdisciplinary team will identify project controls and mitigation measures after evaluating such onsite factors as soil water-holding capacity, EHR, slope and topographic limitations, the quantity of debris: density and ratio of rearranged debris, residual ground cover density objectives, climatic variables, and the probability of creating water-repellant soils.

Implementation: The District Ranger will be responsible for debris treatment following timber sales and other projects such as chaparral manipulation.

Project planners will be responsible for determining the method(s) of debris disposal and/or placement of debris after treatment. Methods of disposal include, but are not limited to: prescribed burning, chipping and mulching, lop and scatter, and mechanical harvesting and collection.

The contracting officer's representative will be responsible for enforcing the contract clauses that provide for debris disposal in contracted projects.

The project leader will implement the water-quality protection measures either through the contract provisions, or by use of force account crews.

**R5 FSH 2509.22 - SOIL AND WATER CONSERVATION HANDBOOK
CHAPTER 10 - WATER QUALITY MANAGEMENT HANDBOOK**

12.51 Exhibit 06

BMP 5.6 - Soil Moisture Limitations for Mechanical Equipment Operations

Objective: To prevent compaction, rutting, and gullyng, with resultant sediment production and turbidity.

Explanation: This is a preventive practice that reduces surface disturbance during wet soil conditions, which would result in compaction, rutting, and gullyng. Soil moisture guidelines will be developed for each site, based on the characteristics of the soil.

The project should then be conducted as guided by soil erodibility, climate factors, soil and water relationships, and mass stability hazards identified by trained and qualified earth scientists (see also BMP 1.5).

Implementation: Soil conditions will be evaluated during the environmental documentation process and the interdisciplinary team will develop operating limitations as the alternatives are formulated. Project planners will also be responsible for including appropriate contract provisions and management requirements in project work plans and environmental documentation.

For force account projects, the project leader will be responsible for determining when the soil surface is unstable and susceptible to damage, and for terminating operations.

The contracting officer's representative will determine when optimum soil conditions exist, and administer the operation to prevent adverse soil effects, in addition to suspending, or terminating operations for contracted projects as soil moisture conditions warrant.

ATTACHMENT B: USFS NATIONAL CORE BMP TECHNICAL GUIDE

USDA

United States
Department of
Agriculture

Forest Service

FS-990a

April 2012



National Best Management Practices for Water Quality Management on National Forest System Lands

Volume 1:
National Core BMP Technical Guide



United States
Department of
Agriculture

Forest Service

FS-990a

April 2012



National Best Management Practices for Water Quality Management on National Forest System Lands

**Volume 1:
National Core BMP Technical Guide**

The U.S. Department of Agriculture (USDA) prohibits discrimination in all its programs and activities on the basis of race, color, national origin, age, disability, and where applicable, sex, marital status, familial status, parental status, religion, sexual orientation, genetic information, political beliefs, reprisal, or because all or part of an individual's income is derived from any public assistance program. (Not all prohibited bases apply to all programs.) Persons with disabilities who require alternative means for communication of program information (Braille, large print, audiotape, etc.) should contact USDA's TARGET Center at (202) 720-2600 (voice and TDD). To file a complaint of discrimination, write USDA, Director, Office of Civil Rights, 1400 Independence Avenue, S.W., Washington, D.C. 20250-9410, or call (800) 795-3272 (voice) or (202) 720-6382 (TDD). USDA is an equal opportunity provider and employer.

Front cover photo: *Taylor Fork Creek, Gallatin National Forest, near Big Sky, MT, by David Scovell, engineer, Rogue River-Siskiyou National Forest. Photo taken in August 2005 in the Madison Range, just west of Yellowstone National Park.*

Acknowledgments

This document is the culmination of an effort that has spanned many years. Countless numbers of Forest Service, U.S. Department of Agriculture, resource personnel at all levels of the agency, including National Forest System, State and Private Forestry, and Research and Development, have participated to make the vision of a National Best Management Practices (BMP) Program a reality. Thank you to all those who provided guidance as part of the steering committee, those who participated in the teams that drafted the initial version of the BMPs, those who developed the BMP monitoring protocols, and the many people across the agency who reviewed drafts of this

document and provided comments. Particular thanks goes to Joan Carlson of the Rocky Mountain Regional Office for her dedication to the development and completion of this document.

Thank you also to our partners—the Association of Clean Water Administrators (formerly the Association of State and Inter-State Water Pollution Control Administrators), the Intertribal Timber Council, the National Association of State Foresters, the National Congress of American Indians, and the U.S. Environmental Protection Agency—who reviewed the document and provided helpful comments.

Preface

This technical guide is the first volume of guidance for the Forest Service, U.S. Department of Agriculture, National Best Management Practices (BMP) Program. The National BMP Program was developed to improve agency performance and accountability in managing water quality consistent with the Federal Clean Water Act (CWA) and State water quality programs. Current Forest Service policy directs compliance with required CWA permits and State regulations and requires the use of BMPs to control nonpoint source pollution to meet applicable water quality standards and other CWA requirements.

The Forest Service has a long history of working with States and other partners to carry out BMP programs, including agreements with the U.S. Environmental Protection Agency (EPA) and many States to use and monitor BMPs. Each Forest Service region has a BMP guidance document consistent with its respective State BMP programs. Most national forests and grasslands monitor and report on BMPs. The regional or forest BMP programs, however, are not standardized to allow efficient cross-regional application, evaluation, or reporting. The National BMP Program, which includes the National Core BMPs detailed in this guide, will enable the agency to readily document compliance with the nonpoint source management strategy at national or regional scales. The National BMP Program is modeled after a successful 20-year-old regional BMP program in the Forest Service Pacific Southwest Region (Region 5).

A standardized National BMP Program is needed as an effective tool for the agency to accomplish the following:

- **Improve water quality to restore impaired waters**—National Forest System (NFS) lands in the United States contain 3,126 CWA 303(d) listed waterbodies; nearly every Forest Service administrative unit (96 percent) has at least one impaired waterbody within its boundaries. BMPs identified in Total Maximum Daily Load restoration plans will improve water quality conditions in impaired waters.
- **Improve relationships with EPA, States, and the public**—Improved Forest Service BMP program performance and accountability will better demonstrate compliance with CWA permit requirements and State nonpoint source programs and build trust between the agency and our partners and stakeholders.
- **Improve the agency's ability to demonstrate results in watershed management**—The Forest Service has made a commitment to implement several accountability tools, including

a National BMP Program, to document improvements in watershed condition as a result of management and restoration actions.

- **Improve the agency's ability to use adaptive management in land management plan implementation**—The National BMP Program will provide a consistent, credible, and affordable agencywide BMP monitoring program with coordinated data collection; monitoring information that can be aggregated at any scale; a database accessible to all Forest Service users; and reports that will be shared with EPA, States, and other partners. This type of monitoring program provides a continuous feedback loop for a successful adaptive management process.
- **Improve National Environmental Policy Act analyses and compliance with other Federal laws**—Improved accountability for water quality management will lead to improved National Environmental Policy Act analysis and documentation and better demonstration of compliance with other Federal laws, such as Endangered Species Act habitat protections for aquatic threatened and endangered species. The agency's ability to respond successfully to water-quality-related appeals and lawsuits will be improved, and management flexibility in decisionmaking will be maintained.

The National BMP Program will provide consistency among Forest Service administrative units to efficiently administer the program and demonstrate improvements in performance and accountability at multiple scales. The National BMP Program consists of four main components: (1) a set of National Core BMPs, (2) a set of standardized monitoring protocols to evaluate implementation and effectiveness of those BMPs, (3) a data management and reporting structure, and (4) corresponding national direction.

The National Core BMPs integrate individual State and Forest Service regional BMPs under one umbrella to facilitate an agencywide BMP monitoring program. The national core set provides general, nonprescriptive BMPs for the broad range of activities that occur on NFS lands. Nearly every BMP in the national core set already exists in current regulations, guidance, or procedures. Adopting a standard national core set of BMPs may change what some national forests and grasslands refer to as their BMPs, but it will not change the substance of site-specific BMP prescriptions. Those prescriptions will continue to be based on State BMPs, regional Forest Service guidance, land management plan standards and guidelines,

BMP monitoring information, and professional judgment. Standardization will improve consistency, ensure that Forest Service resource professionals use best available science to develop site-specific BMP prescriptions, and, ultimately, improve water quality on and downstream of NFS lands.

The national BMP monitoring protocols will be used to supplement existing national forest or grassland BMP monitoring programs for those units that already have programs and provide a foundation for those units that do not. Each national forest and grassland will complete a small number of national BMP monitoring evaluations each year for each of the national core BMPs implemented on the unit. This information will be aggregated over time to provide national- and regional-scale evaluations of BMP performance. Identified deficiencies in either BMP implementation or effectiveness will be used to adjust land and

resource management activities and the BMPs to improve water quality protection.

In summary, the Forest Service National BMP Program is the agency's nonpoint source pollution control program for achieving and documenting water resource protection. The National BMP Program demonstrates the agency's commitment to land stewardship and protection of water quality consistent with the CWA, State regulations, and other requirements. The National BMP Program is not intended in any way to circumvent or interfere with State and tribal CWA programs, rather it is intended to support and assist the States and tribes in their efforts to ensure compliance on NFS lands. The ultimate goal is to restore and maintain the chemical, physical, and biological integrity of the Nation's waters located within or near the national forests and grasslands.

List of Abbreviations

AMP—Allotment Management Plan	FSH—Forest Service Handbook
AMZ—Aquatic Management Zone	FSM—Forest Service Manual
AOI—Annual Operating Instructions	IDT—interdisciplinary team
BAER—Burned Area Emergency Response	IMT—incident management team
BLM—Bureau of Land Management	MVUM—Motor Vehicle Use Map
BMP—Best Management Practice	NEPA—National Environmental Policy Act
CFR—Code of Federal Regulations	NFS—National Forest System
COE—U.S. Army Corps of Engineers	NPDES—National Pollutant Discharge Elimination System
CWA—Clean Water Act	NRCS—Natural Resources Conservation Service
CWE—cumulative watershed effects	RMOs—Road Management Objectives
DSR—Damage Survey Report	ROS—Recreation Opportunity Spectrum
EPA—U.S. Environmental Protection Agency	SPCC—Spill Prevention Control and Countermeasures
ERFO—emergency relief for federally owned roads	TMDL—total maximum daily load
FERC—Federal Energy Regulatory Commission	USDA—U.S. Department of Agriculture
FY—fiscal year	USGS—U.S. Geological Survey

Contents

Acknowledgments.....	iii	Facilities and Nonrecreation Special Uses Management	
Preface.....	v	Activities	39
List of Abbreviations.....	vii	Fac-1. Facilities and Nonrecreation Special Uses	
Part 1. Introduction	1	Planning	40
National BMP Program Purpose and Objectives	1	Fac-2. Facility Construction and Stormwater Control..	41
Scope of Technical Guide.....	2	Fac-3. Potable Water Supply Systems	43
Part 2. Managing Water Quality on National Forest		Fac-4. Sanitation Systems.....	44
System Lands.....	5	Fac-5. Solid Waste Management	45
Federal Clean Water Act.....	5	Fac-6. Hazardous Materials	45
State Nonpoint Source Management Programs.....	6	Fac-7. Vehicle and Equipment Wash Water	46
Forest Service Policy for Water Quality Management.....	7	Fac-8. Nonrecreation Special Use Authorizations.....	47
Plan to Project: Forest Service BMP Process.....	8	Fac-9. Pipelines, Transmission Facilities, and	
Summary	10	Rights-of-Way.....	48
Part 3. National Core Best Management Practices	11	Fac-10. Facility Site Reclamation.....	49
General Planning Activities.....	13	Resources for Facilities and Nonrecreation	
Plan-1. Forest and Grassland Planning	13	Special Uses Management Activities.....	51
Plan-2. Project Planning and Analysis.....	14	Wildland Fire Management Activities.....	52
Plan-3 Aquatic Management Zone Planning	17	Fire-1. Wildland Fire Management Planning	52
Resources for General Planning Activities	18	Fire-2. Use of Prescribed Fire.....	54
Aquatic Ecosystems Management Activities	19	Fire-3. Wildland Fire Control and Suppression	57
AqEco-1. Aquatic Ecosystem Improvement and		Fire-4. Wildland Fire Suppression Damage	
Restoration Planning.....	19	Rehabilitation.....	58
AqEco-2. Operations in Aquatic Ecosystems	21	Resources for Wildland Fire Management Activities...	59
AqEco-3. Ponds and Wetlands.....	23	Minerals Management Activities.....	61
AqEco-4. Stream Channels and Shorelines.....	26	Min-1. Minerals Planning	62
Resources for Aquatic Ecosystems Management		Min-2. Minerals Exploration	65
Activities.....	28	Min-3. Minerals Production.....	66
Chemical Use Management Activities	30	Min-4. Placer Mining.....	69
Chem-1. Chemical Use Planning.....	30	Min-5. Mineral Materials Resource Sites	70
Chem-2. Follow Label Directions	32	Min-6. Ore Stockpiles, Mine Waste Storage and	
Chem-3. Chemical Use Near Waterbodies	32	Disposal, Reserve Pits, and Settling Ponds.....	72
Chem-4. Chemical Use in Waterbodies	34	Min-7. Produced Water.....	75
Chem-5. Chemical Handling and Disposal.....	35	Min-8. Minerals Site Reclamation.....	76
Chem-6. Chemical Application Monitoring and		Resources for Minerals Management Activities.....	78
Evaluation	36	Rangeland Management Activities.....	81
Resources for Chemical Use Management Activities...	37	Range-1. Rangeland Management Planning.....	81
		Range-2. Rangeland Permit Administration	83
		Range-3. Rangeland Improvements.....	84
		Resources for Rangeland Management Activities	85

Recreation Management Activities	87	Mechanical Vegetation Management Activities	128
Rec-1. Recreation Planning	88	Veg-1. Vegetation Management Planning.....	128
Rec-2. Developed Recreation Sites	89	Veg-2. Erosion Prevention and Control	131
Rec-3. Dispersed Use Recreation	90	Veg-3. Aquatic Management Zones.....	132
Rec-4. Motorized and Nonmotorized Trails	91	Veg-4. Ground-Based Skidding and Yarding	
Rec-5. Motorized Vehicle Use Areas.....	93	Operations.....	134
Rec-6. Pack and Riding Stock Use Areas	94	Veg-5. Cable and Aerial Yarding Operations.....	135
Rec-7. Over-Snow Vehicle Use	96	Veg-6. Landings.....	136
Rec-8. Watercraft Launches.....	97	Veg-7. Winter Logging	137
Rec-9. Recreation Special Use Authorizations.....	98	Veg-8. Mechanical Site Treatment.....	138
Rec-10. Ski Runs and Lifts.....	99	Resources for Mechanical Vegetation Management	
Rec-11. Ski Area Snowmaking.....	100	Activities.....	139
Rec-12. Ski Area Facilities	101	Water Uses Management Activities.....	141
Resources for Recreation Management Activities.....	102	WatUses-1. Water Uses Planning.....	142
Road Management Activities	104	WatUses-2. Water Wells for Production and	
Road-1. Travel Management Planning and Analysis..	105	Monitoring	143
Road-2. Road Location and Design.....	107	WatUses-3. Administrative Water Developments.....	144
Road-3. Road Construction and Reconstruction.....	110	WatUses-4. Water Diversions and Conveyances	147
Road-4. Road Operations and Maintenance	111	WatUses-5. Dams and Impoundments.....	149
Road-5. Temporary Roads	114	WatUses-6. Dam Removal.....	151
Road-6. Road Storage and Decommissioning	115	Resources for Water Uses Management Activities	153
Road-7. Stream Crossings.....	117	Glossary	155
Road-8. Snow Removal and Storage	120	References.....	161
Road-9. Parking and Staging Areas	122	APPENDIX A. Forest Service Regional Best Management	
Road-10. Equipment Refueling and Servicing	123	Practices Guidance Documents.....	163
Road-11. Road Storm-Damage Surveys	124	APPENDIX B. Selected State Forestry BMP Documents...	164
Resources for Road Management Activities.....	126		

Part 1. Introduction

High-quality water is one of the most important natural resources coming from the national forests and grasslands. National Forest System (NFS) lands, which represent about 8 percent of the land area of the contiguous United States, contribute 18 percent of the Nation's water supply (Brown et al. 2008; Sedell et al. 2000). About 124 million people rely on NFS lands as the primary source of their drinking water (USDA Forest Service 2008a). In addition to drinking water and other municipal needs, water on NFS lands is important to sustaining populations of fish and wildlife, providing various recreation opportunities, and providing supplies to meet agricultural and industrial needs across the country.

The national forests and grasslands were established to protect the land, secure favorable conditions of water flows, and provide a sustainable supply of goods and services (the Organic Administration Act of 1897). NFS lands are managed using a multiple-use approach with the goal of sustaining healthy terrestrial and aquatic ecosystems while addressing the need for resources, commodities, and services for the American people (USDA Forest Service 2008a). With a growing population and a finite fresh water resource, providing high-quality fresh water supplies is more critical than ever to the social and economic well-being of the United States.

Aquatic Management Zone (AMZ)

An AMZ is an administratively designated zone adjacent to stream channels and other waterbodies. Special management controls aimed at maintaining and improving water quality or other water- and riparian-dependent values, including groundwater-dependent ecosystems, should be applied in the delineated AMZ. The width of the AMZ is determined based on site-specific factors and local requirements. AMZ delineation may encompass the floodplain and riparian areas when present. AMZ designation can have synergistic benefits to other resources, such as maintaining and improving aquatic and riparian area-dependent resources, visual and aesthetic quality, wildlife habitat, and recreation opportunities.

A variety of names for the AMZ concept are used in the States and Forest Service regions: Water Influence Zone (WIZ), Rocky Mountain Region 2 (R2); Stream Environment Zones, Pacific Southwest Region (R5); Riparian Conservation Areas, R5; Riparian Reserves, R5 and Pacific Northwest Region (R6); Riparian Habitat Conservation Areas, R5 and R6; Streamside Management Unit (SMU), R6; Riparian Corridor, Southern Region (R8); Riparian Management Corridor (RMC), Eastern Region (R9); and Riparian Management Area, Alaska Region (R10). For purposes of the National Core BMPs, these areas will be referred to as AMZs.

Forests and grasslands generally produce high-quality water, especially when the ecosystems are healthy and functioning properly. Water quality is influenced by the pattern, magnitude, intensity, and location of land use and management activities. Some land uses can protect or restore water quality, while others may degrade or pose risks to clean water. Excess sediment (turbidity and bedload), nutrients, temperature, hazardous chemicals, and their resulting effects on water chemistry and aquatic habitats, are the most significant water quality issues resulting from land uses and management activities on NFS lands.

Preventing negative water quality impacts is more efficient and effective than attempting to restore the damage. To ensure water quality is protected, the Forest Service, an agency of the U.S. Department of Agriculture (USDA), has developed procedures, methods, and controls, consistent with Federal and State requirements, to address potential pollutants and pollution at their source. Implementation and monitoring of these Best Management Practices (BMPs) is the fundamental basis of the Forest Service water quality management program to protect, restore, or mitigate water quality impacts from activities on NFS lands.

National BMP Program Purpose and Objectives

The purpose of the National BMP Program is to provide a standard set of core BMPs and a consistent means to track and document the use and effectiveness of BMPs on NFS lands across the country. The objectives of the National BMP Program are as follows:

1. To establish uniform direction for BMP implementation to control nonpoint source pollution on all NFS lands to avoid, minimize, or mitigate adverse effects to soil, water quality, and riparian resources that will meet the intent of the Federal and State water quality laws and regulations, Executive orders, and USDA and Forest Service directives.
2. To establish a consistent process to monitor and evaluate Forest Service efforts to implement BMPs and the effectiveness of those BMPs at protecting water quality at national, regional, and forest scales.
3. To establish a consistent and creditable process to document and report agency BMP implementation and effectiveness.

The National BMP Program has four components: a national core set of BMPs, a procedural guide for monitoring BMP implementation and effectiveness, a data management system,

and corresponding national direction. This technical guide contains the national core set of BMPs to be used in the National BMP Program. The national BMP monitoring protocols will be contained in Volume 2 of this technical guide (FS-990b), which is currently being prepared.

Scope of Technical Guide

This technical guide provides information for implementing the National Core BMP portion of the Forest Service National BMP Program. The National Core BMPs were compiled from Forest Service manuals, handbooks, contract and permit provisions, and policy statements, as well as State or other organizations' BMP documents. The National Core BMPs are not intended to supersede or replace existing regional, State, forest, or grassland BMPs. Rather, the National Core BMPs provide a foundation for water quality protection on NFS lands and facilitate national BMP monitoring.

The National Core BMPs encompass the wide range of activities on NFS lands across the Nation. The primary intent of the National Core BMPs is to carry out one of the Clean Water Act (CWA) purposes to maintain the chemical, physical, and biological integrity of the Nation's waters. To that end, the

National Core BMPs are focused on water pollution control. The National Core BMPs also address soil, aquatic, and riparian resources, but only to the extent that they contribute to maintenance of chemical, physical, and biological water quality.

The National Core BMPs in this technical guide are deliberately general and nonprescriptive. Because this document is national in scope, it cannot address all possible practices or practices specific to local or regional soils, climate, vegetation types, or State-specific requirements. The National Core BMPs require the development of site-specific BMP prescriptions based on local site conditions and requirements to achieve compliance with established State, tribal, or national water quality goals. It is expected that State requirements and BMP programs, Forest Service regional guidance, and the land management plan will provide the criteria for site-specific BMP prescriptions. The National Core BMPs provide direction on "what to do" and the local direction will provide direction on "how to do it."

Table 1 contains two examples comparing the National Core BMP direction with Forest Service regional direction and State BMPs. Forest Service regions may supplement the National Core BMPs with additional practices or practices that are more specific to meet regional needs.

Table 1.—Examples of how Forest Service regional direction and State BMPs fit within the National Core BMP framework

National Core BMP	Region 2 WCP ¹	Region 5 BMP ²	Montana BMP ³	Wisconsin BMP ⁴
<p>BMP Plan-3 Aquatic Management Zone (AMZ) Planning</p> <ul style="list-style-type: none"> Determine width of AMZ for waterbodies in the project area that may be affected by the proposed activities. Evaluate the condition of riparian habitat and estimated response to the activity to determine need for and width of AMZ. Use stream class and type, channel condition, aspect, slope, and soils to determine appropriate AMZ width. 	<p>Water Influence Zone (WIZ)</p> <ul style="list-style-type: none"> The WIZ includes the geomorphic floodplain, riparian ecosystem, and inner gorge. The minimum horizontal width is 100 feet or the mean height of mature dominant late-seral vegetation, whichever is most. 	<p>Practice 1-8 Streamside Management Zone (SMZ) Designation</p> <ul style="list-style-type: none"> Identify the SMZ requirements during environmental documentation process. Each forest's land and resource management plan identifies specific measures to protect these zones. At a minimum, forest requirements must be identified and implemented. 	<p>Width of SMZ-Marking Boundary</p> <ul style="list-style-type: none"> The SMZ width is a 50-foot slope distance on each side of streams, lakes, and other bodies of water measured from the ordinary high water mark. In all cases, except on Class 1 and 2 stream segments and lakes where the slope of the SMZ is greater than 35 percent, the SMZ width is 100 feet. 	<p>Riparian Management Zone (RMZ)</p> <ul style="list-style-type: none"> The RMZ for lakes, designated trout streams, and streams 3 feet wide or wider is a strip of land running along the shoreline of lakes and on each side of a stream. It begins at the ordinary high water mark and extends a minimum of 100 feet landward. The RMZ for streams less than 3 feet wide is a strip of land on each side of a stream, beginning at the ordinary high water mark and extending a minimum of 35 feet.
<p>BMP Veg-4 Ground-Based Skidding and Yarding Operations</p> <ul style="list-style-type: none"> Use ground-based yarding systems only where physical site characteristics are suitable to avoid, minimize, or mitigate adverse effects to soil and water quality. Use local direction or requirements for slope, erosion potential, mass wasting potential, and other soil or site properties to determine areas suitable for ground-based yarding systems. 	<p>WCP Management Measure 9</p> <ul style="list-style-type: none"> Limit roads and other disturbed sites to the minimum feasible number, width, and total length consistent with the purpose of specific operations, local topography, and climate. Avoid new roads or heavy equipment use on unstable or highly erodible soils. Avoid ground skidding on sustained slopes steeper than 40 percent and on moderate to severely burned sustained slopes greater than 30 percent. 	<p>Practice 1-9 Determining Tractor Loggable Ground</p> <ul style="list-style-type: none"> Avoid tractor logging where the predicted post-logging erosion hazard cannot be reduced to either "low" or "moderate." 	<p>Timber Harvesting</p> <ul style="list-style-type: none"> Use the logging system that best fits the topography, soil types, and season while minimizing soil disturbance and economically accomplishing silvicultural objectives. Topography considerations for "cut-to-length harvesting"—limited to terrain less than 40 percent slope. 	<p>Timber Harvesting</p> <ul style="list-style-type: none"> Avoid operating equipment where excessive soil compaction and rutting may cause erosion that affects water quality. The use of low ground pressure equipment may allow logging to continue. Where possible, keep skid trail grades less than 15 percent. Grades greater than 15 percent should not exceed 300 feet in length.

¹ Rocky Mountain Region (Region 2) Watershed Conservation Practices (WCP), Forest Service Handbook 2509.25 (2006).

² Pacific Southwest Region (Region 5) Water Quality Management for National Forest System Lands in California—Best Management Practices (USDA Forest Service 2000).

³ Water Quality Best Management Practices for Montana Forests. (Logan 2001).

⁴ Wisconsin's Forestry Best Management Practices for Water Quality (Holaday and Wagner 2010).



Part 2. Managing Water Quality on National Forest System Lands

Federal Clean Water Act

The Federal Clean Water Act (CWA) (33 U.S.C. § 1251 et seq.) is the foundation for surface water quality protection in the United States. The objective of the CWA, as articulated in section 101, is to restore and maintain the chemical, physical, and biological integrity of the Nation's waters. This law uses a variety of regulatory and nonregulatory tools to control direct pollutant discharges from point sources and manage polluted runoff from nonpoint sources to waters of the United States.

In the CWA, Congress gave States and tribes the option for taking primary responsibility for water pollution control. (States will be used in the rest of this report to signify both States and those tribes that have received approval from the U.S. Environmental Protection Agency (EPA) for treatment as a State under the CWA.) As a result, most States and many tribes have taken on that responsibility and, therefore, water quality standards, procedures, rules, and regulations differ from one State to another. The Forest Service, as an agency of the Federal Government, is required to comply with all Federal, State, and local requirements for water pollution control in the same manner and to the same extent as any nongovernmental entity (CWA section 313).

Water Quality Standards

Water quality standards translate the broad goals of the CWA into specific objectives for an individual waterbody. Each State designates uses to be protected for each jurisdictional waterbody within its boundaries. State water quality standards must provide for the protection and propagation of fish, shellfish, and wildlife and for recreation in and on the water, unless those uses have been shown to be unattainable. States must also adopt water quality criteria to protect such designated uses. In addition, each State must adopt an antidegradation policy. This policy is designed to prevent deterioration of existing levels of water quality, and must, in part, maintain existing uses and the level of water quality necessary to protect such uses. States review their water quality standards periodically and, at a minimum, every 3 years. The EPA reviews and approves State water quality standards to ensure consistency with CWA requirements.

States are required to identify all waters that do not meet water quality standards even after mandatory pollution controls are in place. These waterbodies are considered to be impaired and

are placed on the States' biennial 303(d) list. A Total Maximum Daily Load (TMDL) must be developed by the State for all waterbodies on its approved 303(d) list. The TMDL represents the maximum amount of a pollutant that can enter a waterbody without exceeding the water quality standards. The TMDL amount is distributed among all the pollutant sources (point sources, nonpoint sources, and natural background levels) contributing to that particular waterbody. A margin of safety factor is also considered. A TMDL analysis must clearly identify the links between the waterbody use impairment, the causes of the impairment, and the pollutant load reductions needed to meet the applicable water quality standards. EPA reviews and approves TMDLs and must complete the TMDL if it disapproves the State-developed TMDL. TMDLs are used as planning tools by States to develop specific methods or controls used to meet water quality standards in the impaired waterbody. The point source components of a TMDL are implemented through existing enforceable Federal programs (e.g., National Pollutant Discharge Elimination System [NPDES]). Nonpoint source controls (e.g., Best Management Practices [BMPs]) required by a TMDL can be implemented through a voluntary approach or some State and local regulations or other authorities. A specific TMDL implementation plan is not required by the CWA; however, some States require a TMDL implementation plan or watershed restoration plan.

Point Source Pollution Control

Point source pollution is regulated through a permitting program as outlined in CWA sections 401, 402, and 404. Section 401 provides an opportunity for States to ensure that a permit or license issued by the Federal Government meets applicable State water quality requirements. Federal agencies may not issue permits for activities that "may result in any discharge into navigable waters" until the agency obtains certification from the State that the authorized activity will comply with water quality standards. Each State has its own rules and procedures for 401 Certification. Certification generally applies to point source discharges where a 402 or 404 permit is issued by the EPA or the U.S. Army Corps of Engineers (COE) and for Federal Energy Regulatory Commission licenses. Certification may also be required for some Forest Service special use authorizations and mining plan of operations where there would be a point source discharge. Section 401 is a "condition precedent;" that is, 401 Certification must be obtained and proof provided to the Federal agency before the permit or license can be issued.

The NPDES program is described in CWA section 402. NPDES permits, or the State equivalent, regulate point source discharges. A point source discharge is defined as any addition of a pollutant to waters of the United States from a point source (e.g., a discrete conveyance such as pipes or manmade ditches). Aside from stormwater discharge permits, in general, few types of Forest Service administrative activities would require a NPDES permit. The project proponent is responsible for obtaining permit coverage. Section 402 is “condition subsequent” (i.e., the Forest Service can approve the activity before the 402 permit being obtained).

Stormwater discharges occur when runoff generated by rain or snowmelt events flows over land or impervious surfaces and is discharged to waters of the United States through discrete conveyances such as ditches or channels. Stormwater runoff does not percolate into the ground and may pick up and transport debris, chemicals, sediment, or other pollutants as it flows over the land or impervious surfaces. These pollutants could adversely affect water quality if the runoff is not treated before it is discharged into a surface waterbody. Stormwater discharge permits are required for certain categories of industrial activities and construction activities. The “operator,” defined as the one who has operational control over the construction plans and specifications and has day-to-day operational control over activities at the site, is the party that should obtain stormwater permit coverage. The contractor or permittee and the Forest Service may be required to obtain permit coverage if either or both are considered the operator. Permits for industrial or construction activities or other temporary disturbances generally require BMPs as a primary method of controlling and containing stormwater runoff to protect water quality.

CWA section 404 regulates the discharge of dredge or fill materials into waters of the United States. EPA and the COE jointly administer the 404 program. Unless a State has assumed 404 permitting authority, the COE is responsible for issuing 404 permits. Typical Forest Service activities that could require a 404 permit include stream crossings, stream restoration, habitat improvements, activities in wetlands, and spring developments. Certain silviculture activities are exempt from 404 permits (CWA §404[f][1][A], 33 CFR 323.4[a][1] and 40 CFR 232.3[c][1]). Forest roads, as defined by COE guidance, are exempt from needing 404 permits as long as the BMPs detailed in the regulations are used to ensure that flow and circulation patterns and chemical and biological characteristics of the waters of the United States are not impaired (CWA § 404[f][1][E], 33 CFR 323.4[a][6] and 40 CFR 232.3[c][6][i-xv]). General 404 permits (nationwide or regional) have been established for many categories of activities. If a proposed activity cannot be covered

by a general 404 permit, an individual 404 permit is required. The project proponent or permittee is responsible for obtaining the 404 permit. Like section 402, section 404 is “condition subsequent,” so the activity, either a Forest Service project or a third-party activity proposed on National Forest System (NFS) lands, can be approved by the Forest Service before the 404 permit coverage is obtained. The project cannot be implemented until permit coverage is acquired.

Nonpoint Source Pollution Control

The CWA does not regulate nonpoint source pollution. Instead, sections 208 and 319 require States to develop a process to identify, if appropriate, agricultural, silvicultural, and other categories of nonpoint sources of pollution and to set forth procedures and methods, including land use requirements, to control to the extent practicable such sources. Each State has a Nonpoint Source Management Program and Plan that directs how the State will control nonpoint source pollution. The Nonpoint Source Management Plan describes the process, including intergovernmental coordination and public participation, for identifying BMPs to control identified nonpoint sources and to reduce the level of pollution from such sources. States often use these same sets of BMPs as the best approach to control point source discharges, such as stormwater discharges.

After BMPs have been approved by a State, the BMPs may become the primary mechanism for meeting water quality standards from nonpoint source pollution sources in that State. Proper installation, operation, and maintenance of State approved BMPs are presumed to meet a landowner or manager’s obligation for compliance with applicable water quality standards. If subsequent evaluation indicates that approved and properly installed BMPs are not achieving water quality standards, the State should take steps to revise the BMPs, evaluate and, if appropriate, revise water quality standards (designated uses and water quality criteria), or both. Through the iterative process of monitoring and adjusting BMPs and water quality standards, it is anticipated and expected that BMPs will lead to attainment of water quality standards (EPA 1987).

State Nonpoint Source Management Programs

Each State develops a set of BMPs as part of its Nonpoint Source Management Program. In many States, use of BMPs is voluntary; that is, it is encouraged but not required by regulation. Other States have a regulatory framework for nonpoint sources, either through their water quality laws and regulations or forest practices laws and regulations, where use of BMPs is required.

All national forests and grasslands have adopted BMPs consistent with or approved by State nonpoint source management programs. In some States, the Forest Service uses the State BMPs as written, in addition to land management plan direction. In some Forest Service regions, the Forest Service has established BMPs, and the States have agreed that those practices conform to State requirements. In a few instances, Forest Service BMPs have gone through a formal public review process. Forest Service BMPs have been approved by the State and EPA, and the Governor of the State has designated the Forest Service as the water quality management agency for NFS lands within the State. In many States, the Forest Service has entered into an agreement that outlines how the Forest Service will implement that particular State's Nonpoint Source Management Plan on NFS lands (see table 2).

Table 2.—*Forest Service water quality agreements with States as of November 2011*

MAA	MOA	MOU	LOC
AL (1990)	AK (1992)	AZ (2008)	NV (2009)
CA (1981)	WA (2000)	GA (1991)	OR (2002)
MS (1990)		ID (2008)	SC (1990)
		KY (1990)	SD (2009)
		LA (1993)	TN (1997)
		MI (2011)	TX (1991)
		MT (2008)	UT (2009)
		NC (1992)	WV 2010
		NM (2011)	WY (2011)

LOC – Letter of Certification. MAA – Management Agency Agreement. MOA – Memorandum of Agreement. MOU – Memorandum of Understanding.

Forest Service Policy for Water Quality Management

Forest Service Manual (FSM) Direction

Forest Service policy for watershed management is contained in FSM 2500. Watershed management activities on national forests and grasslands are to be implemented in accordance with the general objectives of multiple use and the specific objectives in the land management plan. All management activities of other resources are to be designed to minimize short-term impacts on the soil and water resources and to maintain or enhance long-term productivity, water quantity, and water quality (FSM 2503).

Forest Service policy for watershed management also includes monitoring to assess the degree to which planning, management operation, and maintenance of renewable resources meet established goals and standards (FSM 2525). Soil and water resource monitoring is to be designed and implemented to evaluate effects of each forest management activity or program

on basic soil and water quality and productivity. The objectives of monitoring are to secure data sufficient to assist line officers and resource managers in evaluating the effects of management activities on the soil and water resources and to support changes in management activities to protect soil and water quality.

FSM 2532 provides policy and direction specific to water quality management on NFS lands. The objective of water quality management on NFS lands is to protect and, where needed, improve the physical, chemical, biological, and aesthetic quality of the water resource consistent with the purposes of the national forests and national water quality goals. BMPs are to be promoted and applied to all management activities as the method for control of nonpoint sources of water pollution to achieve established State or national water quality goals. BMPs applied should be based on site-specific conditions and political, social, economic, and technical feasibility. Application of the National BMP Program should constitute compliance with water quality standards. Monitoring methods that reflect nonpoint source conditions should be used to measure effectiveness of those BMPs.

Forest Service Nonpoint Source Strategy

The Forest Service strategy for control of nonpoint source pollution is to apply appropriate BMPs using adaptive management principles. This strategy involves applying approved BMPs, monitoring the implementation and effectiveness of the BMPs, and using the monitoring results to inform and improve management activities. This process is illustrated in figure 1 and outlined in the following list.

1. Approved BMPs are applied to all management activities to control nonpoint sources of water pollution and are used for compliance with established State or national water quality goals.
 - a. Site-specific BMP prescriptions, consistent with the National Core BMPs, are developed using regional or State BMPs and land management plan direction.
 - b. BMP prescriptions are properly installed and maintained to minimize impacts of current management activities to protect and maintain water quality.
2. BMP implementation and effectiveness are monitored using National Core BMP monitoring protocols and reporting systems.
 - a. Field evaluations are used to monitor BMP implementation to determine whether appropriate site-specific BMP prescriptions were planned and implemented as intended.

- b. Field evaluations of appropriate parameters or surrogates are used to monitor BMP effectiveness to determine if the applied practices met the desired objective(s).
 - c. BMP monitoring data is managed in the established corporate data system and analyzed at national, regional, and forest or grassland levels.
3. BMP monitoring results are used to inform and improve management activities.
- a. The results of BMP monitoring and best available science are used, in collaboration with Federal, State, and local agencies and partners as appropriate, to improve administrative procedures and BMP practices and applications.
 - b. Corrective actions are initiated where implementation monitoring indicates that BMPs have been implemented, but effectiveness monitoring indicates that BMP objectives were not met.

- c. Changes in water quality designated uses and standards are recommended as necessary, in coordination with the appropriate agency.
4. Monitoring results and findings are documented and shared with appropriate Federal, State, and local agencies.

Plan to Project: Forest Service BMP Process

The Forest Service BMP Process consists of the following steps to incorporate BMPs into project planning and on-the-ground implementation to ensure water quality is protected.

BMP Selection and Design

Water quality goals and objectives are established in the land management plan (see BMP Plan-1 Forest and Grassland Planning). These goals are specific to each individual national forest or grassland and are intended to meet or exceed applicable legal requirements including the CWA and State water quality regulations. A land management plan may also specify BMPs as standards and guidelines to be used to meet those goals and objectives.

Figure 1. Forest Service Nonpoint Source Strategy

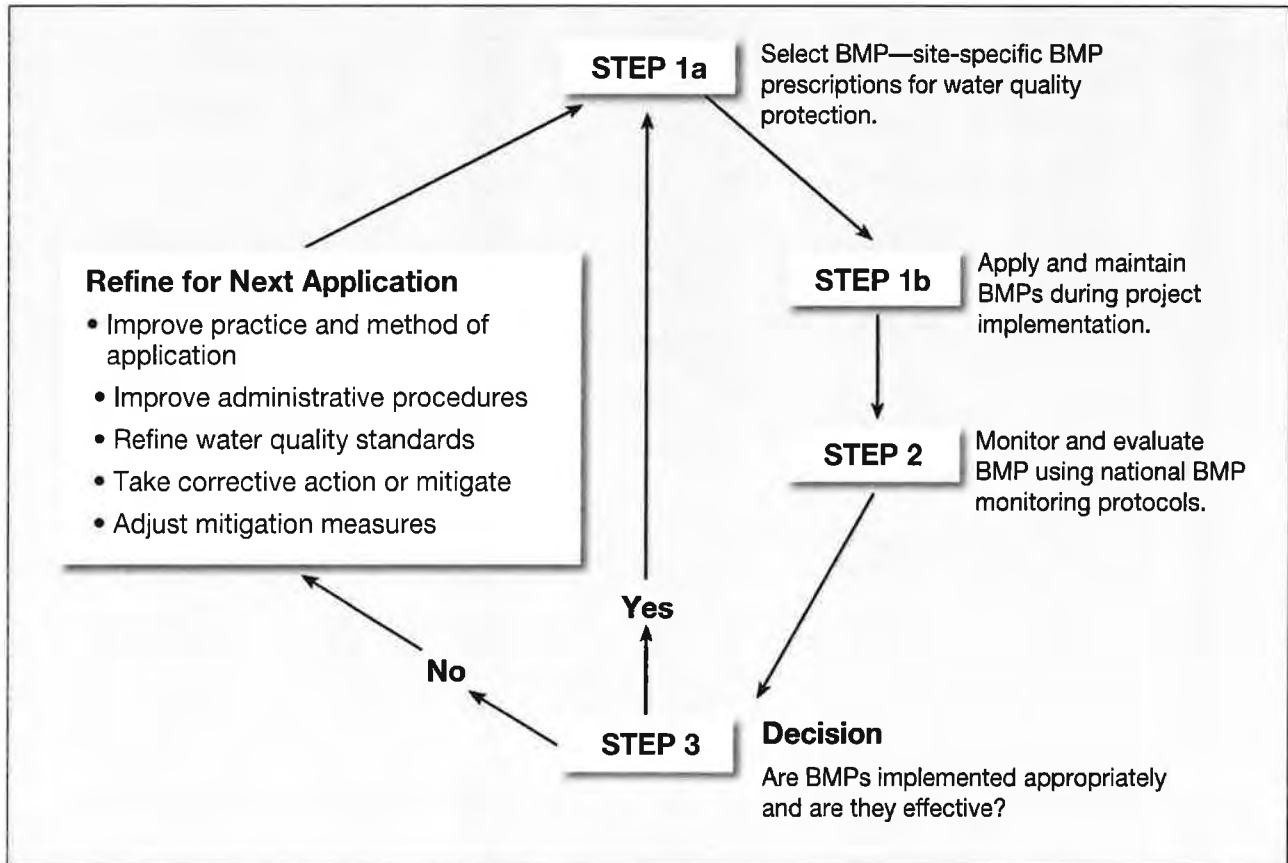

The project planning process starts when a project or resource management activity is proposed. A project may be initiated by the Forest Service to implement some aspect of the land management plan, or may be proposed by an outside party that wants to occupy or use NFS lands for a specific purpose, such as for mining, a commercial recreation development, or a utility facility. When a project is initiated, the responsible official, usually the local district ranger or forest supervisor, appoints an interdisciplinary team (IDT) to complete the appropriate environmental analysis as required by the National Environmental Policy Act (NEPA) to inform the decision on the project or activity.

In the project planning and environmental analysis process, the IDT selects appropriate or required BMPs to be used to achieve land management plan water quality goals and objectives (see BMP Plan-2 Project Planning and Analysis). BMPs are selected to fit local conditions, resource values, and designated uses of water. Site-specific BMP prescriptions are developed based on the proposed activity, water quality objectives, soils, topography, geology, vegetation, climate, and other site-specific factors and are designed to avoid, minimize, or mitigate potential adverse impacts to soil, water quality, and riparian resources. State BMPs, regional Forest Service guidance, land management plan standards and guidelines, monitoring results, and professional judgment are all used to develop site-specific BMP prescriptions. During the planning process, CWA or other State-required permits or certifications are also identified. The site-specific BMP prescriptions and other permit requirements are described and disclosed in the NEPA analysis document or project file. The responsible official considers the information provided by the IDT and makes a decision on which site-specific BMP prescriptions will be applied to the project.

BMP Application

The site-specific BMP prescriptions are translated into contract provisions, special use authorization requirements, project plan specifications, and other similar documents. This ensures that the operator or person responsible for applying the BMPs is required to do so. Implementation of projects or other management activities are supervised by Forest Service personnel to ensure the site-specific BMP prescriptions are implemented according to the contract, permit, or plan. During project or activity implementation, site-specific BMP prescriptions are adjusted as needed to better fit current site conditions. As part of project, contract, or permit administration, project or activity inspections are completed as needed to identify BMP deficiencies or maintenance needs. BMP application is documented in the appropriate project-related documents.

BMP Monitoring and Adjustment

Implementation and effectiveness of applied BMPs are monitored to inform and improve future management activities. BMP implementation monitoring asks the question: “Did we do what we said we were going to do?” BMP effectiveness monitoring evaluates whether the BMPs were effective in meeting management objectives and protecting designated uses.

Programmatic BMP Monitoring in The Pacific Southwest Region Best Management Practices Evaluation Program

The Forest Service Pacific Southwest Region has a Management Agency Agreement with the State of California requiring the Forest Service to incorporate BMPs into land and resource management activities and to monitor their implementation and effectiveness. Since 1992, the region has been monitoring BMPs using its BMP Evaluation Program. The Forest Service evaluates BMP implementation and effectiveness at randomly selected sites using 29 different monitoring protocols. Every year, the region assigns each national forest system unit a certain number of evaluations to complete. From fiscal year (FY) 2003 to FY 2007, the Forest Service completed 2,861 onsite evaluations; an average of 572 per year. The Forest Service rated BMPs as implemented on 86 percent of those evaluations and effective on 89 percent. Overall, 93 percent of the BMPs that were rated as implemented were also judged effective.

This monitoring has shown that BMPs are effective at protecting water quality when they are properly implemented. From this monitoring, the Pacific Southwest Region has concluded that the greatest opportunity for improving water quality is to improve implementation of the BMPs, particularly for recreation activities and mining. The region has planned steps to improve BMP implementation and effectiveness including BMP implementation checklists for projects, reviews of national forest staffing levels, and revision of BMPs that have relatively low effectiveness when implemented properly (USDA Forest Service 2009a).

The Forest Service Nonpoint Source Strategy uses “programmatic monitoring” to evaluate BMP implementation and effectiveness; that is, aside from project administration described above. BMPs are not monitored on every project or activity that occurs on NFS lands. Projects to monitor or specific monitoring sites are selected in a manner that results in objective and representative data on BMP implementation and effectiveness. Often, a random or systematic random selection procedure is used to choose monitoring locations across a forest or grassland where specific activities or BMPs are targeted. In some cases, a national forest or ranger district will choose a small number of projects to review using an IDT process. BMP monitoring results are summarized in land management plan monitoring reports.

Programmatic BMP monitoring is used for a variety of purposes. The adequacy of specific BMPs or management activities at protecting water quality can be evaluated. These results can be used to inform future environmental analysis of similar projects under similar conditions. For example, programmatic BMP monitoring on the Flathead and Kootenai National Forests in Montana has found that, since 1988, BMPs were effective 99.3 percent of the time when properly applied on glacial till soils (USDA Forest Service 2009b).

Programmatic BMP monitoring can assess administrative processes for selecting and applying appropriate BMPs over time or geographic area. After several years of BMP monitoring on silviculture activities, the Black Hills National Forest in South Dakota and Wyoming found that BMPs were generally being implemented and, when implemented, were effective in the timber sale units that were inspected. The BMP monitoring identified some issues with road drainage, however. As a result, the forest engineering and watershed staff together developed recommendations to improve their BMPs for road drainage (USDA Forest Service 2010a). In another example, the North Carolina National Forests compared BMP implementation and effectiveness on timber sales as monitored from 1992 to 2000 to BMP monitoring results in 2009 and 2010 (USDA Forest Service 2010b). Overall BMP implementation improved from 68 percent in the earlier monitoring period to 92 percent in 2009 and 2010. BMP effectiveness also improved from 73 percent in 1992 to 2000 to 93 percent in 2009 and 2010.

Montana's Forestry BMP Audits

The Montana Department of Natural Resources and Conservation, Forestry Division, has evaluated forest practices for BMP implementation and effectiveness every 2 years since 1990 (Ziesak 2010). The Forestry Division has evaluated timber harvest sites on Federal, State, and private lands. Over all ownerships, BMP implementation has improved from 78 percent rated as "meets or exceeds criteria" in 1990 to 97 percent in 2010. Similarly, BMP effectiveness has also improved, from 80 percent rated as providing "adequate protection" in 1990 to 98 percent in 2010. BMP implementation and effectiveness on timber harvest sites on NFS lands has been consistently rated high over the past few audit cycles.

	2010	2008	2006
BMP Implementation	96%	96%	93%
BMP Effectiveness	98%	96%	95%
Streamside Management Zone (SMZ) Implementation	94%	99%	100%
SMZ Effectiveness	95%	99%	100%

In addition to BMP monitoring by the Forest Service, many States monitor BMP implementation and effectiveness on timber sale projects on NFS lands. These State audits are generally completed every 3 to 5 years, or annually in some States. The audit teams are comprised of State employees, Forest Service and other Federal agency employees, representatives from the timber industry, and landowners. Selected timber sale projects on private and State lands are audited along with projects on NFS lands. In general, BMP implementation and effectiveness on NFS lands as rated by these State audit teams compares favorably with, and often exceeds, the BMP performance on private or State lands.

Summary

The Forest Service policy for control of nonpoint sources of pollution is to use BMPs, monitor the implementation and effectiveness of those BMPs, and adjust management practices using monitoring results. An administrative unit IDT identifies the appropriate BMPs for a project during the planning process and develops site-specific BMP prescriptions based on site conditions, State BMPs, and other local guidance or requirements. The responsible official considers the information provided by the IDT and makes a decision on which site-specific BMP prescriptions will be applied to the project. Unit staff monitor BMPs and summarize monitoring data at the forest or grassland level in either project documentation or the land management plan monitoring reports.

The National BMP Program provides core BMPs and BMP monitoring protocols for all activities on NFS lands. In the past, most of the BMP monitoring has focused on timber harvest sites and associated roads. The National BMP Program expands that to include all activities by providing consistent monitoring protocols for recreation, livestock grazing, fire and fuels, and minerals, in addition to vegetation management and roads. The National BMP Program will also have an associated data management system that will facilitate documentation and reporting of BMP monitoring results at national forest or grassland, regional, or national scales.

Part 3. National Core Best Management Practices

This part describes the Forest Service National Core Best Management Practices (BMPs). The National Core BMPs are intended for use on National Forest System (NFS) lands as part of the Forest Service strategy for water quality management. The National Core BMPs are grouped into the following resource categories:

- Plan General Planning Activities
- AqEco Aquatic Ecosystems Management Activities
- Chem Chemical Use Management Activities
- Fac Facilities and Nonrecreation Special Uses Management Activities
- Fire Wildland Fire Management Activities
- Min Minerals Management Activities
- Range Rangeland Management Activities
- Rec Recreation Management Activities
- Road Road Management Activities
- Veg Mechanical Vegetation Management Activities
- WatUses Water Uses Management Activities

With the exception of the General Planning Activities being listed first, the sequence in which these resource categories are presented has no intended significance. Planning is important to managing potential management activity impacts to achieve water quality goals and objectives and, therefore, is listed first.

Each BMP is organized according to the following format:

Title	Includes the sequential number of the BMP within the resource category and title of the BMP.
Reference	Identifies the Forest Service Manual or Handbook direction pertinent to the BMP.
Objective	Describes the desired results or attainment of the BMP as it relates to maintaining chemical, physical, and biological water quality.
Explanation	Provides background information to provide context for the BMP. Describes criteria or standards used when applicable.
Practices	Lists recommended methods to achieve the BMP objectives.

The National Core BMPs are deliberately general and nonprescriptive. Although some impacts may be thought of as characteristic of a management activity, the actual potential for a land use or management activity to impact water quality depends on:

1. The physical, biologic, meteorological, and hydrologic environment where the activity takes place (e.g., topography, physiography, precipitation, stream type, channel density, soil type, and vegetative cover).
2. The type of activity imposed on a given environment (recreation, mineral exploration, and vegetation management) and the proximity of the activity area to surface waters.
3. The magnitude, intensity, duration, and timing of the activity (grazing system used, types of silvicultural practices used, constant use as opposed to seasonal use, recurrent application, or one-time application).

4. The State designated beneficial uses of the water in proximity to the management activity and their relative sensitivity to the potential impacts associated with the activity.

These four factors vary throughout the lands administered by the Forest Service. It follows then, that the extent and kind of potential water quality impacts from activities on NFS lands are variable, as are the most appropriate mitigation and pollution control measures. No solution, prescription, method, or technique is best for all circumstances.

The National Core BMPs cannot include all possible practices or techniques to address the range of conditions and situations on all NFS lands. **Each BMP in this document has a list of recommended practices that should be used, as appropriate or when required, to meet the objective of the BMP. Not all recommended practices will be applicable in all settings, and there may be other practices not listed in the BMP that would work as well, or better, to meet the BMP objective in a given situation.** The specific practices or methods to be applied to a particular project should be determined based on site evaluation, past experience, monitoring results, new techniques based on new research literature, and other requirements. **State BMPs, Forest Service regional guidance, land management plans, BMP monitoring information, and professional judgment should be used to develop site-specific BMP prescriptions.**

For example, BMP Road-4 (Road Operations and Maintenance) dictates that roads should be correctly maintained to drain and disperse water runoff to minimize the erosive effects of concentrated water flow. Some methods for draining a road are to outslope the road prism, install dips, and lead out ditches or inslope the road to a ditch line and install culverts. It is during the onsite evaluation of a specific road project that the appropriate method or combination of methods to drain the road correctly is identified. The practice is, thereby, custom fit to the physical and biological environment of the project area.

After the site-specific BMP prescription is developed, it must then be included in the appropriate National Environmental Policy Act decision document and project contract or operation plan. For example, if roadwork is part of a timber harvest project, the timber sale contract is used to implement the methods for road drainage. For a hard rock mine operation, the roadwork BMP prescriptions would be included in the mining plan of operation. Roadwork BMP prescriptions would be implemented via a ski area's operation and maintenance plan for roads within a ski resort.

The National Core BMPs are grouped by resource category for ease of organization. The applicable BMPs should be used for an activity regardless of which resource grouping the BMP is listed in. For example, BMPs for Mechanical Vegetation Management Activities should be used, as appropriate, for tree removal activities in developed campgrounds. Likewise, Road Management Activity BMPs apply whether the road is for timber harvesting, mining, recreation access, or some other purpose. The specific implementing document and responsible individual will differ by resource area (e.g., recreation development plan and recreation staff officer for a recreation project, and a timber sale contract and timber sale administrator for a timber sale), but the responsibility to maintain and improve water quality is shared by all and not necessarily vested with a given resource functional area.

At the end of each resource category is a listing of additional BMP resources, including publications and Web sites, applicable to the subject resource category. The resources listed are not all inclusive; other technical resources should be consulted as needed and required.

General Planning Activities

Planning is an important Best Management Practice (BMP) for water quality management. In the planning process, potential impacts to water quality, and impacts to other resources like soils or riparian areas that may affect water quality, can be identified. In addition, requirements from laws or regulations, the land management plan, State BMPs, or other documents can be incorporated into the project design. This information can be used to shape the proposed action, develop alternatives to the proposed action, and determine appropriate site-specific BMP prescriptions to avoid, minimize, or mitigate impacts to meet water quality objectives.

Three National Core BMPs are in the General Planning Activities category. These planning BMPs are to be used during Forest Service planning processes for projects and activities on National Forest System (NFS) lands. BMP Plan-1 (Forest and Grassland Planning) contains guidance on what to include in a land management plan to provide direction for management of water quality within a plan area. BMP Plan-2 (Project Planning and Analysis) contains planning practices common to most Forest Service resource management activities. BMP Plan-2 should be used for all Forest Service activities and authorizations that could affect water quality. BMP Plan-3 (Aquatic Management Zone Planning) contains planning practices common to management of Aquatic Management Zones (AMZ).

In addition, each resource category section in this technical guide includes a planning BMP specific to the management activities addressed in that section. The activity-planning BMPs provide additional practices specific to those management activities.

States will be used in the rest of this resource category to signify both States and those tribes that have received approval from the U.S. Environmental Protection Agency (EPA) for treatment as a State under the Clean Water Act (CWA).

General Planning BMPs	
Plan-1	Forest and Grassland Planning
Plan-2	Project Planning and Analysis
Plan-3	Aquatic Management Zone Planning

Plan-1. Forest and Grassland Planning

Manual or Handbook

Reference Forest Service Manual (FSM) 1900, FSM 1920, Forest Service Handbook (FSH) 1909.12, and FSM 2511.

Objective Use the land management planning and decisionmaking processes to incorporate direction for water quality management consistent with laws, regulation, and policy into land management plans.

Explanation The overall goal of managing NFS lands is to sustain the multiple uses of renewable resources in perpetuity while maintaining the long-term productivity of the land. Federal laws, such as the National Forest Management Act and the CWA, provide additional goals to protect or maintain and improve or restore the quality of soil and water on NFS lands. These goals are codified as policy in the Forest Service manuals and handbooks.

Forest Service planning is an integrated process composed of discrete parts—the strategic plan, land management plans, and project and activity plans. The Forest Service Strategic Plan identifies

long-term strategic priorities and is the basis for integrated delivery of the agency’s mission. The land management plan blends national and regional priorities from the strategic plan with local forest or grassland capability and needs. The land management plan establishes desired conditions to be achieved through management of NFS lands in the planning area to best meet the needs of the American people. The land management plan provides desired conditions, objectives, and guidance for site-specific project and activity decisions. Project-level plans describe on-the-ground projects and activities designed to achieve long-term objectives and desired conditions described in the land management plan while reflecting current local needs and issues.

The land management plan provides integrated direction for the management, protection, and use of all resources in the planning area under the principles of multiple use and sustained yield. In the land management plan, issues, concerns, and opportunities related to soil and water resources are resolved; desired conditions, goals, and objectives for soil, water, and riparian resources are established; and standards and guidelines for management of soil, water quality, and riparian resources are provided.

- Practices**
- Establish desired conditions, goals, and objectives for soil, water quality, and riparian resources that contribute to the overall sustainability of social, economic, and ecological systems in the plan area consistent with established State or national water quality goals for the plan area.
 - Consider the water quantity, quality, location, and timing of flows needed to provide water supplies for municipal, agricultural, commercial, and industrial uses; hydropower generation; water recreation, transportation, and spiritual uses; aesthetic appreciation; and tourism to contribute to social and economic sustainability.
 - Consider the water quantity, quality, location, and timing of flows needed to provide the ecological conditions to support diversity of native and desired nonnative plants and animal species in the plan area to contribute to ecological sustainability.
 - Include plan objectives to maintain or, where appropriate, improve or restore watershed conditions to achieve desired conditions of soil, water quality, and riparian resources.
 - Consider watershed characteristics, current and expected environmental conditions (including climate change), and potential effects of land uses when determining suitability of NFS lands within the planning area for various uses.
 - Include standards and guidelines to maintain and, where appropriate, improve over time the quality of soil, water resources, and riparian areas when implementing site-specific projects and activities.
 - Include monitoring questions and associated performance measures to address watershed condition and water quality goals and objectives.

Plan-2. Project Planning and Analysis

Manual or Handbook

Reference FSM 1950, FSH 1909.15, and FSM 2524.

Objective Use the project planning, environmental analysis, and decisionmaking processes to incorporate water quality management BMPs into project design and implementation.

Explanation The project planning, environmental analysis, and decisionmaking process is the framework for incorporating water quality management BMPs into project design and implementation. The process should identify likely direct, indirect, or cumulative impacts from the proposed project or

management activities on soils, water quality, and riparian resources in the project area. Project documents (plans, contracts, permits, etc.) should include site-specific BMP prescriptions to meet water quality objectives as directed by the environmental analysis. Project planning should ensure that activities are consistent with land management plan direction; State BMPs, floodplain, wetland, coastal zone; and other requirements including CWA 401 certification, CWA 402 permits, and CWA 404 permits; wilderness or wild and scenic river designations; and other Federal, State, and local rules and regulations.

- Practices**
- Include watershed specialists (hydrologist, soil scientist, geologist, and fish biologist) and other trained and qualified individuals on the interdisciplinary team for project planning, environmental analysis, and decisionmaking to evaluate onsite watershed characteristics and the potential environmental consequences of the proposed activity(s).
 - Determine water quality management objectives for the project area.
 - Identify water quality management desired conditions and objectives from the land management plan.
 - Identify and evaluate the condition of water features in the project area (e.g., streams, lakes, ponds, reservoirs, wetlands, riparian areas, springs, groundwater-dependent ecosystems, recharge areas, and floodplains).
 - Identify State-designated beneficial uses of waterbodies and the water quality parameters that are critical to those uses.
 - Identify locations of dams and diversions for municipal or irrigation water supplies, fish hatcheries, stockwater, fire protection, or other water uses within the project area.
 - Identify any impaired (e.g., 303[d] listed) waterbodies in the project area and associated Total Maximum Daily Load (TMDL) analyses or other restoration plans that may exist.
 - Identify threatened, endangered, or sensitive species in or near water, wetlands, and riparian areas in the project area and their habitat needs related to water quality.
 - Determine potential or likely direct and indirect impacts to chemical, physical, and biological water quality, and watershed condition from the proposed activity.
 - Always assume hydrological connections exist between groundwater and surface water in each watershed, unless it can reasonably be shown none exist in a local situation.
 - Consider the impacts of current and expected environmental conditions such as atmospheric deposition and climate change in the project area when analyzing effects of the proposed activities.
 - Evaluate sources of waterbody impairment, including water quantity, streamflows, and water quality, and the likelihood that proposed activities would contribute to current or future impairment or restoration to achieve desired watershed conditions.
 - Identify and delineate unstable areas in the project area.
 - Identify soil limitations and productivity impacts of proposed activities.
 - Verify preliminary findings by inspecting the sites in the field.
 - Develop site-specific BMP prescriptions, design criteria, and mitigation measures to achieve water quality management objectives. Consult local, regional, State, or other agencies' required or recommended BMPs that are applicable to the activity.
 - Consider enhanced BMPs identified in a TMDL or other watershed restoration plan to protect impaired waterbodies within the project area.

-
- Use site evaluations, professional experience, monitoring results, and land management plan standards, guidelines, and other requirements.
 - Identify Federal, State, and local permits or requirements needed to implement the project. Examples include water quality standards, CWA 401 certification, CWA 402 permits (including stormwater permits), CWA 404 permits, and Coastal Zone Management Act requirements.
 - Plan to limit surface disturbance to the extent practicable while still achieving project objectives.
 - Designate specific AMZs around water features in the project area (see BMP Plan-3 [AMZ Planning]).
 - Design activities on or near unstable areas and sensitive soils to minimize management-induced impacts.
 - Use local direction and requirements for prevention and control of terrestrial and aquatic invasive species.
 - Use suitable tools to analyze the potential for cumulative watershed effects (CWE) to occur from the additive impacts of the proposed project and past, present, and reasonably foreseeable future activities on NFS and neighboring lands within the project watersheds.
 - Consider the natural sensitivity or tolerance of the watershed based on geology, climate, and other relevant factors.
 - Consider the existing condition of the watershed and water quality as a reflection of past land management activities and natural disturbances.
 - Estimate the potential for adverse effects to soil, water quality, and riparian resources from current and reasonably foreseeable future activities on all lands within the watershed relative to existing watershed conditions.
 - Use land management plan direction; Federal, State, or local water quality standards; and other regulations to determine acceptable limits for CWE.
 - Modify the proposed project or activity as necessary by changing project design, location, and timing to reduce the potential for CWE to occur.
 - Consider including additional mitigation measures to reduce project effects.
 - Identify and implement opportunities for restoration activities to speed recovery of watershed condition before initiating additional anthropogenic disturbance in the watershed.
 - Coordinate and cooperate with other Federal, State, and private landowners in assessing and preventing CWE in multiple ownership watersheds.
 - Integrate restoration and rehabilitation needs into the project plan.
 - Consider water quality improvement actions identified in a TMDL or other watershed restoration plan to restore impaired waterbodies within the project area.
 - Identify project-specific monitoring needs.
 - Document site-specific BMP prescriptions, design criteria, mitigation measures, and restoration, rehabilitation, and monitoring needs in the applicable National Environmental Policy Act (NEPA) documents, design plans, contracts, permits, authorizations, and operation and maintenance plans.
 - Delineate all protected or excluded areas, including, for example, AMZs and waterbodies, 303(d) listed and TMDL waterbodies, and municipal supply watersheds, on the project map.

Plan-3 Aquatic Management Zone Planning

Manual or Handbook

Reference FSM 2526.

Objective To maintain and improve or restore the condition of land around and adjacent to waterbodies in the context of the environment in which they are located, recognizing their unique values and importance to water quality while implementing land and resource management activities.

Explanation The land around and adjacent to waterbodies plays an important ecologic role in maintaining the structure, function, and processes of the aquatic ecosystem. These areas provide shading, soil stabilization, sediment and water filtering, large woody debris recruitment, and habitat for a diversity of plants and animals. The quality and quantity of water resources and aquatic habitats may be adversely affected by ground-disturbing activities that occur on these areas. Because of the importance of these lands, various legal mandates have been established pertaining to management of these areas, including, but not limited to, those associated with floodplains, wetlands, water quality, endangered species, wild and scenic rivers, and cultural resources. Protection and improvement of soil, water, and vegetation are to be emphasized while managing these areas under the principles of multiple use and sustained yield. Riparian-dependent resources are to be given preferential consideration when conflicts among land use activities occur.

Designation of a zone encompassing these areas around and adjacent to a waterbody is a common BMP to facilitate management emphasizing aquatic and riparian-dependent resources. These management zones are known by several common terms such as streamside management area or zone, riparian management area, stream environment zone, and water influence zone. For purposes of the National Core BMPs, these areas will be referred to as AMZs.

AMZs are intended to be large enough to protect a waterbody and its associated beneficial uses and aquatic and riparian ecosystems. AMZs along streams and rivers may be linear swaths extending a prescribed distance from a bank, though widths are usually adjusted to include features such as riparian vegetation and unstable landforms as well as critical floodplain components necessary to sustain waterbody integrity and protect beneficial uses. AMZ areas around wetlands, lakes, and other nonlinear features may be irregular in shape to encompass sensitive riparian areas and other water-dependent features.

Local regulation often stipulates the area and extent of AMZs and may be listed in land management plans; biological opinions, evaluations, or assessments; and other regional or State laws, regulations, and policies. Virtually all States have BMPs that include AMZs, as do most land management plans.

Practices Develop site-specific BMP prescriptions for the following practices, as appropriate or when required, using State BMPs, Forest Service regional guidance, land management plan direction, BMP monitoring information, and professional judgment.

- Proactively manage the AMZ to maintain or improve long-term health and sustainability of the riparian ecosystem and adjacent waterbody consistent with desired conditions, goals, and objectives in the land management plan.
 - Balance short-term impacts and benefits with long-term goals and desired future conditions, considering ecological structure, function, and processes, when evaluating proposed management activities in the AMZ.
- Determine the width of the AMZ for waterbodies in the project area that may be affected by the proposed activities:

- Evaluate the condition of aquatic and riparian habitat and beneficial riparian zone functions and their estimated response to the proposed activity in determining the need for and width of the AMZ.
- Use stream class and type, channel condition, aspect, side slope steepness, precipitation and climate characteristics, soil erodibility, slope stability, groundwater features, and aquatic and riparian conditions and functions to determine appropriate AMZ widths to achieve desired conditions in the AMZ.
- Include riparian vegetation within the designated AMZ and extend the AMZ to include steep slopes, highly erodible soils, or other sensitive or unstable areas.
- Establish wider AMZ areas for waters with high resource value and quality.
- Design and implement project activities within the AMZ to:
 - Avoid or minimize unacceptable impacts to riparian vegetation, groundwater recharge areas, steep slopes, highly erodible soils, or unstable areas.
 - Maintain or provide sufficient ground cover to encourage infiltration, avoid or minimize erosion, and to filter pollutants.
 - Avoid, minimize, or restore detrimental soil compaction.
 - Retain trees necessary for shading, bank stabilization, and as a future source of large woody debris.
 - Retain floodplain function.
 - Restore existing disturbed areas that are eroding and contributing sediment to the waterbody.
- Mark the boundaries of the AMZ and sensitive areas like riparian areas, wetlands, and unstable areas on the ground before land disturbing activities.

Resources for General Planning Activities

NEPA Holcomb, J. 1994. Guide for soil/water/air environmental effects analysis in NEPA documents. Atlanta, GA: U.S. Department of Agriculture, Forest Service, Southern Region. 36 p. Available at http://fsweb.r8.fs.fed.us/nr/bio_phy_res/water/Literature.shtml.

U.S. Environmental Protection Agency, Office of Federal Activities. 1999. Considering ecological processes in environmental impact assessments, July 1999. Washington, DC. 90 p. Available at <http://www.epa.gov/compliance/resources/policies/nepa/index.html>.

Riparian Management Committee on Riparian Zone Functioning and Strategies for Management, Water Science and Technology Board, National Research Council. 2002. Riparian areas: functions and strategies for management. ISBN: 0-309-12784-X. Washington, DC: National Academies Press. 444 p. Available at <http://www.nap.edu/catalog/10327.html>.

Everest, F.H.; Reeves, G.H. 2007. Riparian and aquatic habitats of the Pacific Northwest and southeast Alaska: ecology, management history and potential management strategies. Gen. Tech. Rep. PNW-GTR-692. Portland, OR: U.S. Department of Agriculture, Forest Service, Pacific Northwest Research Station. 130 p. Available at <http://www.treearch.fs.fed.us/pubs/27434>.

Verry, E.S.; Hornbeck, J.W.; Dolloff, C.A., eds. 2000. Riparian management in forests of the continental Eastern United States. ISBN: 9781566705011. Boca Raton, FL: Lewis Publishers CRC Press. 432 p.

Aquatic Ecosystems Management Activities

The purpose of this set of Best Management Practices (BMPs) is to avoid, minimize, or mitigate adverse effects to soil, water quality, and riparian resources that may result from construction and maintenance activities in flowing and nonflowing aquatic ecosystems. Properly functioning streams, lakes, riparian areas, and wetlands are critical in maintaining water quality, water quantity, riparian habitat, aquatic fauna populations and diversity, and downstream beneficial uses. Common management activities in waterbodies include constructing ponds and wetlands, restoring streambanks or channels, and improving or restoring aquatic habitat.

Four National Core BMPs are in the Aquatic Ecosystems Management Activities category. These BMPs are to be used for projects and activities in or near waterbodies on National Forest System (NFS) lands. BMP AqEco-1 (Aquatic Ecosystem Improvement and Restoration Planning) is a planning BMP for improvement or restoration activities in aquatic ecosystems. BMP AqEco-2 (Operations in Aquatic Ecosystems) covers practices for working in or near waterbodies. Applicable practices of this BMP should be used whenever working in or near waterbodies, regardless of the resource activity; for example, when constructing a stream crossing (BMP Road-7 [Stream Crossings]) or mining instream gravel deposits (BMP Min-5 [In-Stream Sand and Gravel Mining]). BMP AqEco-3 (Ponds and Wetlands) is for constructing ponds and wetlands and constructing or maintaining structures in these aquatic ecosystems. BMP AqEco-4 (Stream Channels and Shorelines) is for construction and maintenance activities in stream channels and shorelines. Note BMP Road-7 (Stream Crossings) provides additional direction specific to road-stream crossings.

States will be used in the rest of this resource category to signify both States and those tribes that have received approval from the U.S. Environmental Protection Agency (EPA) for treatment as a State under the Clean Water Act (CWA).

Aquatic Ecosystems BMPs	
AqEco-1	Aquatic Ecosystem Improvement and Restoration Planning
AqEco-2	Operations in Aquatic Ecosystems
AqEco-3	Ponds and Wetlands
AqEco-4	Stream Channels and Shorelines

AqEco-1. Aquatic Ecosystem Improvement and Restoration Planning

Manual or Handbook

Reference Forest Service Manual (FSM) 2020.

Objective Reestablish and retain ecological resilience of aquatic ecosystems and associated resources to achieve sustainability and provide a broad range of ecosystem services.

Explanation Every waterbody has unique characteristics that should be considered when developing a site-specific maintenance, improvement, or restoration strategy. Planning is critical to ensure that the project is conducted in a timely and cost-efficient manner and that the ecological and water quality goals are met. A rigorous approach that uses a combination of best available science and professional experience to inform planning is necessary to enhance the potential for long-term success. When planning aquatic ecosystem projects, it is important to understand all the factors that may affect the watershed currently and in the future. These factors include water quantity, quality, flow,

or storage capacity; habitat suitability for native plants, fish, and wildlife; climate change; the primary uses of the watershed and waterbody by people, domestic animals, and wildlife; and past alterations to the waterbody.

Practices Develop site-specific BMP prescriptions for the following practices, as appropriate or when required, using State BMPs, Forest Service regional guidance, land management plan direction, BMP monitoring information, and professional judgment.

- Use a watershed perspective and available watershed assessments when planning aquatic ecosystem improvement or restoration projects.
 - Consider how existing water quality and habitat conditions at the project site have been affected by past habitat alterations, hydrologic modification, and riparian area changes in the watershed.
 - Consider how past, current, and future land use patterns may affect the proposed project site.
 - Recognize that inhabitants and users at the site (beaver, deer, birds, and people) may change the current ecosystem state to suit their needs.
- Use desired future conditions to set project goals and objectives.
 - Establish desired future conditions that are consistent with the land management plan's goals and direction.
 - Use a reference condition to determine the natural potential water quality and habitat conditions of a waterbody.
 - Consider the potential for future changes in environmental conditions, such as changes in precipitation and runoff type, magnitude and frequency, community composition and species distribution, and growing seasons that may result from climate change.
 - Consider water quality and other habitat needs for sensitive aquatic or aquatic-dependent species in the project area.
- Favor project alternatives that correct the source of the degradation more than alternatives that mitigate, or treat symptoms of, the problem.
 - Consider the risk and consequences of treatment failure, such as the risk that design conditions could be exceeded by natural variability before the treatment measures are established, when analyzing alternatives.
 - Consider as a first priority treatment measures that are self-sustaining or that reduce requirements for future intervention.
- Use natural stabilization processes consistent with stream type and capability where practicable rather than structures when restoring damaged streambanks or shorelines.
- Prioritize sites to implement projects in a sequence within the watershed in such a way that they will be the most effective to achieve improvement or restoration goals.

AqEco-2. Operations in Aquatic Ecosystems

Manual or Handbook

Reference None known.

Objective Avoid, minimize, or mitigate adverse impacts to water quality when working in aquatic ecosystems.

Explanation Common construction or maintenance operations in waterbodies often involve ground disturbance. The close proximity to, and contact with, the waterbody increases the potential for introducing sediment and other pollutants that can affect water quality. This BMP includes practices for minimizing direct and indirect water quality impacts when working in or adjacent to waterbodies.

Practices Develop site-specific BMP prescriptions for the following practices, as appropriate or when required, using State BMPs, Forest Service regional guidance, land management plan direction, BMP monitoring information, and professional judgment.

- Use applicable practices of BMP Plan-2 (Project Planning and Analysis) and BMP Plan-3 (AMZ Planning) when planning operations in aquatic ecosystems.
- Identify the aquatic and aquatic-dependent species that live in the waterbody, Aquatic Management Zone (AMZ), or on the floodplain and their life histories to determine protection strategies, such as timing of construction, sediment management, species relocation, and monitoring during construction.
- Coordinate stream channel, shoreline, lake, pond, and wetland activities with appropriate State and Federal agencies.
 - Incorporate Clean Water Act (CWA) 404 permit requirements and other Federal, State, and local permits or requirements into the project design and plan.
- Use suitable measures to protect the waterbody when preparing the site for construction or maintenance activities.
 - Clearly delineate the work zone.
 - Locate access and staging areas near the project site but outside of work area boundaries, AMZs, wetlands, and sensitive soil areas.
 - Refuel and service equipment only in designated staging areas (see BMP Road-10 [Equipment Refueling and Servicing]).
 - Develop an erosion and sediment control plan to avoid or minimize downstream impacts using measures appropriate to the site and the proposed activity (see BMP Fac-2 [Facility Construction and Stormwater Control]).
 - Prepare for unexpected failures of erosion control measures.
 - Consider needs for solid waste disposal and worksite sanitation.
 - Consider using small, low ground pressure equipment, and hand labor where practicable.
 - Ensure all equipment operated in or adjacent to the waterbody is clean of aquatic invasive species, as well as oil and grease, and is well maintained.
 - Use vegetable oil or other biodegradable hydraulic oil for heavy equipment hydraulics wherever practicable when operating in or near water.
- Schedule construction or maintenance operations in waterbodies to occur in the least critical periods to avoid or minimize adverse effects to sensitive aquatic and aquatic-dependent species that live in or near the waterbody.

-
- Avoid scheduling instream work during the spawning or migration seasons of resident or migratory fish and other important life history phases of sensitive species that could be affected by the project.
 - Avoid scheduling instream work during periods that could be interrupted by high flows.
 - Consider the growing season and dormant season for vegetation when scheduling activities within or near the waterbody to minimize the period of time that the land would remain exposed, thereby reducing erosion risks and length of time when aesthetics are poor.
 - Use suitable measures to protect the waterbody when clearing the site.
 - Clearly delineate the geographic limits of the area to be cleared.
 - Use suitable drainage measures to improve the workability of wet sites.
 - Avoid or minimize unacceptable damage to existing vegetation, especially plants that are stabilizing the bank of the waterbody.
 - Use suitable measures to avoid or minimize impacts to the waterbody when implementing construction and maintenance activities.
 - Minimize heavy equipment entry into or crossing water as is practicable.
 - Conduct operations during dry periods.
 - Stage construction operations as needed to limit the extent of disturbed areas without installed stabilization measures.
 - Promptly install and appropriately maintain erosion control measures.
 - Promptly install and appropriately maintain spill prevention and containment measures.
 - Promptly rehabilitate or stabilize disturbed areas as needed following construction or maintenance activities.
 - Stockpile and protect topsoil for reuse in site revegetation.
 - Minimize bank and riparian area excavation during construction to the extent practicable.
 - Keep excavated materials out of the waterbody.
 - Use only clean, suitable materials that are free of toxins and invasive species for fill.
 - Properly compact fills to avoid or minimize erosion.
 - Balance cuts and fills to minimize disposal needs.
 - Remove all project debris from the waterbody in a manner that will cause the least disturbance.
 - Identify suitable areas offsite or away from waterbodies for disposal sites before beginning operations.
 - Contour site to disperse runoff, minimize erosion, stabilize slopes, and provide a favorable environment for plant growth.
 - Use suitable species and establishment techniques to revegetate the site in compliance with local direction and requirements per FSM 2070 and FSM 2080 for vegetation ecology and prevention and control of invasive species.
 - Use suitable measures to divert or partition channelized flow around the site or to dewater the site as needed to the extent practicable.
 - Remove aquatic organisms from the construction area before dewatering and prevent organisms from returning to the site during construction.

- Return clean flows to channel or waterbody downstream of the activity.
 - Restore flows to their natural stream course as soon as practicable after construction or before seasonal closures.
- Inspect the work site at suitable regular intervals during and after construction or maintenance activities to check on quality of the work and materials and identify need for midproject corrections.
- Consider short- and long-term maintenance needs and unit capabilities when designing the project.
 - Develop a strategy for providing emergency maintenance when needed.
- Include implementation and effectiveness monitoring to evaluate success of the project in meeting design objectives and avoiding or minimizing unacceptable impacts to water quality.
- Consider long-term management of the site and nearby areas to promote project success.
 - Use suitable measures to limit human, vehicle, and livestock access to site as needed to allow for recovery of vegetation.

AqEco-3. Ponds and Wetlands

Manual or Handbook

Reference None known.

Objective Design and implement pond and wetlands projects in a manner that increases the potential for success in meeting project objectives and avoids, minimizes, or mitigates adverse effects to soil, water quality, and riparian resources.

Explanation Ponds and wetlands are developed for a variety of reasons including recreation, water sources, stock ponds, gravel extraction, wetland mitigation, and wildlife improvement. The excavation of material and construction of berms, dikes, dams, channels, wildlife water sources, and waterfowl nesting islands have the potential to introduce sediment and other pollutants into adjacent waterbodies, alter flows, and cause physical damage to the ponds and adjacent stream channels both during and after construction. Constructing the projects to withstand potential overflow and flooding is a primary consideration during project planning and design.

Practices Develop site-specific BMP prescriptions for the following practices, as appropriate or when required, using State BMPs, Forest Service regional guidance, land management plan direction, BMP monitoring information, and professional judgment.

- Use applicable practices of BMP AqEco-2 (Operations in Aquatic Ecosystems) when working in or near waterbodies.
- Obtain and manage water rights.
- Clearly define goals and objectives in the project plan appropriate to the site for desired hydrology, wetland plant community associations, intended purpose, and function of the pond or wetland and expected values.
- Select sites based on an analysis of landscape structure and associated ecological functions and values.
 - Construct ponds and wetlands on sites that have easy construction access where practicable.
 - Construct wetlands in landscape positions and soil types capable of supporting desired wetland functions and values.

-
- Construct ponds outside of active floodplain to minimize overflow of groundwater-fed ponds into adjacent streams and avoid or minimize erosion of pond embankments by floods, unless location in the floodplain is integral to achieving project objectives.
 - Construct ponds with surface water supply off-channel rather than placing a dam across a stream.
 - Construct ponds and wetlands on sites with soils suitable to hold water with minimal seepage loss and that provide a stable foundation for any needed embankments.
 - Construct ponds and wetlands in locations where polluted surface water runoff or groundwater discharge do not reach the pond.
 - Consider the consequences of dam or embankment failure and resulting damage from sudden release of water on potentially affected areas.
 - Ensure that the natural water supply for the pond or wetland is sufficient to meet the needs of the intended use and that it will maintain the desired water levels and water quality.
 - Design the wetland to create hydrologic conditions (including the timing of inflow and outflow, duration, and frequency of water level fluctuations) that provide the desired wetland functions and values.
 - Avoid or minimize drawdown effects in a stream source by limiting timing and rate of water withdrawal to allow sufficient downstream water flow to maintain desired conditions in the source stream (see BMP WatUses-1 [Water Uses Planning]).
 - Design the wetland project to create a biologically and hydrologically functional system.
 - Design for function, not form.
 - Keep the design simple and avoid over engineering.
 - Design the project for minimal maintenance needs.
 - Use natural energies, such as gravity flow, in the design.
 - Avoid use of hard engineering structures or the use of supplemental watering to support system hydrology.
 - Plan to allow wetland system time to develop after construction activities are complete.
 - Design the pond or wetland to be of sufficient size and depth appropriate for the intended use and to optimize hydrologic regimes and wetland plant community development.
 - Size the pond or wetland appropriately for the contributing drainage area such that a desired water level can be maintained during drought conditions and that excess runoff during large storms can be reasonably accommodated without constructing large overflow structures.
 - Size the pond or wetland to an adequate depth to store sufficient amounts of water for the intended use and offset probable evaporation and seepage losses.
 - Integrate design with the natural topography of the site to minimize site disturbance.
 - Design the pond or wetland to have an irregular shape to reduce wind and wave impacts, disperse water flows, maximize retention times, and better mimic natural systems.
 - Create microtopography and macrotopography in wetlands to mimic natural conditions and achieve hydrologic and vegetative diversity.
 - Avoid creating large areas of shallow water to minimize excessive evaporation losses and growth of noxious aquatic plants.

-
- Avoid steep-sloped shorelines in areas with potential substrate instability problems to reduce erosion and sedimentation.
 - Include water control structures to manage water levels as necessary.
 - Design spillway or outlet to maintain desired water level under normal inflows from snowmelt, groundwater flow, and precipitation.
 - Design discharge capacity using a suitable hydrologic analysis of the drainage area to be sufficient to safely pass the flow resulting from the design storm event.
 - Size the spillway to release floodwaters in a volume and velocity that do not erode the spillway, the area beyond the outlet, or the downstream channel.
 - Consider the need for suitable measures to drain the pond or wetland.
 - Return overflow back to the original source to the extent practicable.
 - Use suitable measures to maintain desired downstream temperatures, dissolved oxygen levels, and aquatic habitats when water is released from the pond or impoundment.
 - Use materials appropriate for the purpose of the pond and site.
 - Select materials for a dam or embankment that will provide sufficient strength and, when properly compacted, will be tight enough to avoid or minimize excessive or harmful percolation of water through the dam or embankment.
 - Design the side slopes appropriately for the material being used to ensure stability of the dam or embankment.
 - Use wetland vegetation species and establishment methods suitable to the project site and objectives, consistent with local direction and requirements per FSM 2070 and FSM 2080 for vegetation ecology and prevention and control of invasive species.
 - Consider the timing of planting to achieve maximum survival, proposed benefit of each plant species, methods of planting, proposed use of mulch, potential soil amendment (organic material or fertilizer), and potential supplemental watering to help establish the plant community.
 - Properly maintain dams, embankments, and spillways to avoid or minimize soil erosion and leakage problems.
 - Use suitable measures to avoid or minimize erosion of dams and shores due to wind and wave action.
 - Design sufficient freeboard to avoid or minimize overtopping by wave action or other causes.
 - Stabilize or armor spillways for ponds with continuous flow releases or overflow during heavy rainfall events.
 - Manage uplands and surrounding areas to avoid or minimize unacceptable impacts to water quality in the pond or wetland.

AqEco-4. Stream Channels and Shorelines

Manual or Handbook

Reference None known.

Objective Design and implement stream channel and lake shoreline projects in a manner that increases the potential for success in meeting project objectives and avoids, minimizes, or mitigates adverse effects to soil, water quality, and riparian resources.

Explanation Instream projects are often conducted for a variety of purposes, including improving fish and wild-life habitat, stabilizing streambanks, reconnecting the stream channel to the historic floodplain, and removing or replacing culverts. Lakeshores may be degraded by storm events; constant wave action from boats; onshore uses, including recreation, mining, vegetation management, and development; water diversions; freezing and thawing; floating ice; drought; or a fluctuating water table. A shoreline problem is often isolated and may require only a simple patch repair. Methods to stabilize or restore lakeshores differ from streambank measures because of wave action and littoral transport.

Two basic categories of stabilization and protection measures exist: those that work by reducing the force of water against a streambank or shoreline and those that increase their resistance to erosive forces. Appropriate selection and application of stream channel and shoreline protection measures depend on specific project objectives and site conditions.

Practices Develop site-specific BMP prescriptions for the following practices, as appropriate or when required, using State BMPs, Forest Service regional guidance, land management plan direction, BMP monitoring information, and professional judgment.

All Activities

- Use applicable practices of BMP AqEco-2 (Operations in Aquatic Ecosystems) when working in or near waterbodies.

Stream Channels

- Determine stream type and classification using suitable accepted protocols.
- Determine need to control channel grade to avoid or minimize erosion of channel bed and banks before selecting measures for bank stabilization or protection.
 - Incorporate grade control measures into project design as needed.
- Determine design flows based on the value or safety of area to be protected, repair cost, and the sensitivity and value of the ecological system involved.
 - Obtain peak flow, low flow, channel forming flow, and flow duration estimates.
 - Use these estimates to determine the best time to implement the project, as well as to select design flows.
- Determine design velocities appropriate to the site.
 - Limit maximum velocity to the velocity that is nonscouring on the least resistant streambed and bank material.
 - Consider needs to transport bedload through the reach when determining minimum velocities.
 - Maintain the depth-area-velocity relationship of the upstream channel through the project reach.
 - Consider the effects of design velocities on desired aquatic organism habitat and passage.

-
- Avoid changing channel alignment unless the change is to reconstruct the channel to a stable meander geometry consistent with stream type.
 - Design instream and streambank stabilization and protection measures suitable to channel alignment (straight reach versus curves).
 - Consider the effects of ice and freeze and thaw cycles on streambank erosion processes.
 - Consider the effects that structures may have on downstream structures and stream morphology, including streambanks, in the maintenance of a natural streambed.
 - Design channels with natural stream pattern and geometry and with stable beds and banks; provide habitat complexity where reconstruction of stream channels is necessary.
 - Consider sediment load (bedload and suspended load) and bed material size to determine desired sediment transport rate when designing channels.
 - Avoid relocating natural stream channels.
 - Return flow to natural channels, where practicable.
 - Include suitable measures to protect against erosion around the edges of stabilization structures.
 - Design revetments and similar structures to include sufficient freeboard to avoid or minimize overtopping at curves or other points where high-flow velocity can cause waves.
 - Use suitable measures to avoid or minimize water forces undermining the toe of the structure.
 - Tie structures into stable anchorage points, such as bridge abutments, rock outcrops, or well-vegetated stable sections, to avoid or minimize erosion around the ends.
 - Add or remove rocks, wood, or other material in streams only if such action maintains or improves stream condition, provides for safety and stability at bridges and culverts, is needed to avoid or minimize excessive erosion of streambanks, or reduces flooding hazard.
 - Leave rocks and portions of wood that are embedded in beds or banks to avoid or minimize channel scour and maintain natural habitat complexity.
 - Choose vegetation appropriate to the site to provide streambank stabilization and protection adequate to achieve project objectives.
 - Use vegetation species and establishment methods suitable to the project site and objectives, consistent with local direction and requirements per FSM 2070 and FSM 2080 for vegetation ecology and prevention and control of invasive species.

Shorelines

- Use mean high- and low-water levels to determine the design water surface.
 - Consider the effects of fluctuating water levels, freeze or thaw cycles, and floating ice on erosion processes at the site.
- Design stabilization and protection measures suitable to the site.
 - Determine the shoreline slope configuration above and below the waterline.
 - Consider the effects of offshore depth, dynamic wave height, and wave action on shoreline erosion processes.
 - Determine the nature of the bank soil material to aid in estimating erosion rates.
 - Consider foundation material at the site when selecting structural measures.

- Use vegetation species and establishment methods suitable to the project site and objectives and consistent with local direction and requirements per FSM 2070 and FSM 2080 for vegetation ecology and prevention and control of invasive species.
- Consider the rate, direction, supply, and seasonal changes in littoral transport when choosing the location and design of structural measures.
- Consider the effect structures may have on adjacent shoreline or other nearby structures.
 - Adequately anchor end sections to existing stabilization measures or terminate in stable areas.

Resources for Aquatic Ecosystems Management Activities

General Meitl, J.; Maguire, T., eds. 2003. Compendium of best management practices to control polluted runoff: A source book. Boise, ID: Idaho Department of Environmental Quality. Available at http://www.deq.State.id.us/water/data_reports/surface_water/nps/reports.cfm#bmps.

U.S. Environmental Protection Agency (EPA), Office of Water. 2005. National management measures to protect and restore wetlands and riparian areas for the abatement of nonpoint source pollution. EPA-841-B-05-003. Washington, DC. Available at <http://www.epa.gov/owow/nps/wetmeasures/>.

Bioengineering Eubanks, C.E.; Meadows, D. 2002. A soil bioengineering guide for streambank and lakeshore stabilization. FS-683P. San Dimas, CA: U.S. Department of Agriculture (USDA), Forest Service, Technology and Development Program. 188 p. Available at <http://www.fs.fed.us/publications/soil-bio-guide/>.

Pond Construction Deal, C.; Edwards, J.; Pellman, N.; Tuttle, R. 1997. Ponds—Planning, design and construction. Agriculture Handbook 590. Washington, DC: USDA Natural Resources Conservation Service (NRCS). 85 p. Available at <http://www.in.nrcs.gov/pdf%20files/PONDS.PDF>.

Shoreline Stabilization USDA NRCS. 1996. Chapter 16 streambank and shoreline protection. Engineering Field Handbook Part 650. Washington, DC. Available at <http://directives.sc.egov.usda.gov/>.

Stream Restoration Bernard, J.; Fripp, J.F.; Robinson, K.R., eds. 2007. Part 654 stream restoration design national engineering handbook (210-VI-NEH). Washington DC: USDA NRCS.

Federal Interagency Stream Restoration Working Group (FISRWG). 1998. Stream corridor restoration: Principles, processes, and practices. GPO Item No. 0120-A; SuDocs No. A 57.6/2:EN 3/PT.653. ISBN-0-934213-59-3. Available at <http://www.nrcs.usda.gov/wps/portal/nrcs/detailfull/national/water/quality/?&cid=stelprdb1043448>.

Izaak Walton League of America. 2006. A handbook for stream enhancement and stewardship, 2nd ed. ISBN 0-939923-98-X. Blacksburg, VA: McDonald and Woodward and Gaithersburg, MD: The Izaak Walton League of America. 178 p. Available at <http://www.mwpubco.com/conservation.htm>.

USDA NRCS. National conservation practice standards—322 channel bank vegetation, 584 channel stabilization, 410 grade stabilization structure, 580 streambank and shoreline protection, 395 stream habitat improvement and management. Washington, DC. Available at <http://www.nrcs.usda.gov/technical/standards/nhcp.html>.

USDA NRCS. National design construction and soil management center stream corridor restoration. Available at <http://www.ndcsmc.nrcs.usda.gov/technical/Stream/index.html#Materials>.

Wetlands EPA, Office of Water. Information and other resources on constructed wetlands are available at <http://water.epa.gov/type/wetlands/restore/cwetlands.cfm>.

Interstate Technology and Regulatory Council, Mitigation Wetlands Team. 2005. Characterization, design, construction, and monitoring of mitigation wetlands. WTLND-2. Washington, DC. Available at <http://www.itrcweb.org>.

Olson, R. 1999. Constructing wetlands in the Intermountain West: Guidelines for land resource managers. Laramie, WY: University of Wyoming. 52 p. Available at <http://www.wyomingextension.org/agpubs/B-1078.pdf>.

USDA NRCS. National conservation practice standards—658 wetland creation, 659 wetland enhancement, 657 wetland restoration. Washington, DC. Available at <http://www.nrcs.usda.gov/technical/standards/nhcp.html>.

Chemical Use Management Activities

The purpose of this set of Best Management Practices (BMPs) is to avoid or minimize unacceptable impacts to water quality conditions that may result from application of chemicals used to manage biological and physical resources. Chemical treatments are applied to kill, attract, repel, defoliate, stimulate, or retard biologic growth with the intent to mitigate, control, grow, or kill the intended biota. They may also be applied to ameliorate, neutralize, or stabilize certain physical resources such as soil or water chemistry. Chemical treatments include application of pesticides such as insecticides, herbicides, fungicides, nematocides, rodenticides, and piscicides. Chemical treatments also include fertilizers, fire retardants (see BMP Fire-3 [Wildland Fire Control and Suppression]), dyes, or other materials used in tracer studies, aggregate additives like salt, magnesium chloride, and other substances used for dust abatement, roadbed stabilization, or de-icing of roadways, and other chemical products that can be used to fulfill specific Forest Service management objectives.

Six National Core BMPs are in the Chemical Use Management Activities category. These BMPs are to be used when chemicals are applied on National Forest System (NFS) lands. BMP Chem-1 (Chemical Use Planning) is a planning BMP for chemical applications. BMP Chem-2 (Follow Label Directions) specifies following label directions to meet legal requirements for chemical use. BMP Chem-3 (Chemical Use near Waterbodies) is for chemical applications on or over upland areas where chemicals may drift or runoff into waterbodies. BMP Chem-4 (Chemical Use in Waterbodies) is for chemical applications directly into waterbodies. BMP Chem-5 (Chemical Handling and Disposal) provides practices for proper transportation and storage of chemicals, cleaning equipment, and chemical containers and disposal of containers. BMP Chem-6 (Chemical Application Monitoring and Evaluation) provides guidance on designing and implementing monitoring plans to evaluate chemical applications.

States will be used in the rest of this resource category to signify both States and those tribes that have received approval from the U.S. Environmental Protection Agency (EPA) for treatment as a State under the Clean Water Act (CWA).

Chemical Use BMPs	
Chem-1	Chemical Use Planning
Chem-2	Follow Label Directions
Chem-3	Chemical Use Near Waterbodies
Chem-4	Chemical Use in Waterbodies
Chem-5	Chemical Handling and Disposal
Chem-6	Chemical Application Monitoring and Evaluation

Chem-1. Chemical Use Planning

Manual or Handbook

Reference Forest Service Manual (FSM) 2153; Forest Service Handbook (FSH) 2109.14, chapter 10.

Objective Use the planning process to develop measures to avoid, minimize, or mitigate adverse effects to soil, water quality, and riparian resources from chemical use on NFS lands.

Explanation Pollution risk from chemical use depends on chemical mobility and persistence, application mode and rate, and distance from water. Risk of entry to surface water is highest for broadcast and aerial

treatments and for fine droplets. Risk to groundwater is highest over sandy soils, shallow water tables, and groundwater recharge areas. The planning process is the framework for incorporating measures to avoid or minimize impacts to soil and water resources into project design and management to reduce the risk of contamination from chemical use.

Practices Develop site-specific BMP prescriptions for the following practices, as appropriate or when required, using State BMPs, Forest Service regional guidance, land management plan direction, BMP monitoring information, and professional judgment.

- Use applicable practices of BMP Plan-2 (Project Planning and Analysis) and BMP Plan-3 (Aquatic Management Zone [AMZ] Planning) when planning activities that involve use of chemicals.
- Identify municipal supply watersheds; private domestic water supplies; fish hatcheries; and threatened, endangered, and sensitive aquatic dependent species and fish populations near or downstream of chemical treatment areas.
- Use Integrated Pest Management as the basis for all pesticide-use prescriptions in consultation with the unit Pesticide Use Coordinator.
- Select chemical products suitable for use on the target species or that meet project objectives.
 - Use chemicals that are registered for the intended uses.
- Consult the Materials Safety Data Sheet and product label for information on use, hazards, and safe handling procedures for chemicals products under consideration for use.
- Consider chemical solubility, absorption, breakdown rate properties, and site factors when determining which chemical products to use.
 - Use chemicals with properties such that soil residual activity will persist only as long as needed to achieve treatment objectives.
 - Consider soil type, chemical mobility, distance to surface water, and depth to groundwater to avoid or minimize surface water and groundwater contamination.
- Use a suitable pressure, nozzle size, and nozzle type combination to minimize off-target drift or droplet splatter.
- Use selective treatment methods for target organisms to the extent practicable.
- Specify management direction and appropriate site-specific response measures in project plans and safety plans (FSH 2109.14, chapter 60).
- Ensure that planned chemical use projects conform to all applicable local, State, Federal, and agency laws, regulations, and policies.
 - Obtain necessary permits, including Clean Water Act (CWA) 402 permit coverage.
 - Develop spill contingency plans.
 - Obtain or provide training and licensing as required by the label and State regulations.

Chem-2. Follow Label Directions

Manual or Handbook

Reference FSH 2109.14, chapter 50.

Objective Avoid or minimize the risk of soil and surface water or groundwater contamination by complying with all label instructions and restrictions required for legal use.

Explanation Directions found on the label of each chemical are detailed, specific, and include legal requirements for use. In brief, "...the label is the law..." with respect to chemical use. Not following label directions increases the risk of adverse effects to surface water or groundwater as a result of using chemicals inappropriate to the site, an inappropriate method of application, and an inappropriate application rate (too much or too little) to meet project objectives.

Practices Develop site-specific BMP prescriptions for the following practices, as appropriate or when required, using State BMPs, Forest Service regional guidance, land management plan direction, BMP monitoring information, and professional judgment.

- Incorporate constraints identified on the label and other legal requirements of application into project plans and contracts.
 - Be aware that States may have more restrictive requirements than the label instructions.
- Use fully trained individuals equipped with appropriate personal protective equipment to apply chemical treatments.
- Obtain State or Federal Pesticide Application Certification for staff supervising or applying chemical treatment application if required by law.
- Notify contractor's field supervisor when violations of label or project requirements have occurred.
- Stop operations that pose a safety hazard or when violations of project requirements have not been rectified.
- Report label violations to the appropriate enforcement agency.
- Respond to and report spills and other accidents.

Chem-3. Chemical Use Near Waterbodies

Manual or Handbook

Reference FSH 2109.14 Chapters 10, 50.

Objective Avoid or minimize the risk of chemical delivery to surface water or groundwater when treating areas near waterbodies.

Explanation Some chemicals used in terrestrial applications are toxic to aquatic flora and fauna, may overly enrich aquatic systems, and may pose a human health hazard if drinking water sources are contaminated during or after chemical applications. During application, chemicals may drift into waterbodies or other nontarget areas. After application, chemicals or chemical residues may enter surface water or groundwaters through runoff and leaching. Most State and local water quality standards include a general narrative standard that requires surface waters to be free from substances attributable to human-caused discharges in amounts, concentrations, or combinations that are toxic to humans, animals, plants, or aquatic life. To help protect surface waters and wetlands from contamination, a buffer zone of land and vegetation adjacent to the waterbody may need to be designated. Treatment within this zone may differ from that applied to upland areas or the buffer zone may be left untreated if necessary.

-
- Practices** Develop site-specific BMP prescriptions for the following practices, as appropriate or when required, using State BMPs, Forest Service regional guidance, land management plan direction, BMP monitoring information, and professional judgment.
- Identify during project planning those perennial and intermittent surface waters, wetlands, springs, riparian areas, and groundwater recharge areas that may be impacted by the chemical use.
 - Use field observations to verify the extent of these areas identified from aerial observations, maps, or geographic information system data, as needed.
 - Determine the width of a buffer zone, if needed, based on a review of the project area, characteristics of the chemical to be used, and application method.
 - Consider the designated uses of water, adjacent land uses, expected rainfall, wind speed and direction, terrain, slope, soils, and geology.
 - Consider the persistence, mobility, toxicity profile, and bioaccumulation potential of any chemical formulation proposed for use.
 - Consider the type of equipment, spray pattern, droplet size, application height, and experience in similar projects.
 - Prescribe chemicals and application methods in the buffer zone suitable to achieve project objectives while minimizing risk to water quality.
 - Flag or otherwise mark or identify buffer zones as needed.
 - Clearly communicate to those applying the chemical what areas are to be avoided or where alternative treatments are to be used.
 - Locate operation bases on upland areas, outside of wetlands or areas with channel or ditch connection to surface water and AMZs.
 - Use clean equipment and personnel to collect water needed for mixing.
 - Calibrate application equipment to apply chemicals uniformly and in the correct quantities.
 - Evaluate weather conditions before beginning spray operations and monitor throughout each day to avoid or minimize chemical drift.
 - Apply chemicals only under favorable weather conditions as identified in the label instructions.
 - Avoid applying chemicals before forecasted severe storm events to limit runoff and ensure the chemical reaches intended targets.
 - Suspend operations if project prescription or weather limitations have been exceeded.
 - Apply fertilizers during high nutrient-uptake periods to avoid or minimize leaching and translocation.
 - Base fertilizer type and application rate on soils and foliar analysis.
 - Use slow release fertilizers that deliver fertilizer to plants during extended periods in areas with long growing seasons when appropriate to meet project objectives.
 - Monitor during chemical applications to determine if chemicals are reaching surface waters (see BMP Chem-6 [Chemical Application Monitoring and Evaluation]).
 - Implement the chemical spill contingency plan elements within the project safety plan if a spill occurs (FSH 2109.14, chapter 60).

Chem-4. Chemical Use in Waterbodies

Manual or Handbook

Reference FSH 2109.14.

Objective Avoid, minimize, or mitigate unintended adverse effects to water quality from chemical treatments applied directly to waterbodies.

Explanation Chemicals may be used to improve the growth of aquatic fauna and flora within lakes and streams, control invasive or other undesirable aquatic species, restore native biota, or remediate adverse atmospheric deposition. Chemicals may also be used as tracers for time of travel studies, dispersion studies, discharge measurement, and calculation of stream re-aeration, as well as for determining circulation and stratification within reservoirs, tagging pollutants, or many other applications. Several factors affect the type and degree of impacts on aquatic resources, including chemical type, concentration, application rate, residence time, and decay rate; waterbody chemistry, volume, substrate, turnover, inflow, outflow, hydrograph, geology, geomorphology, designated uses, and other limnologic characteristics; and biologic species composition, habitat requirements, food web, population dynamics, and desired condition. Chemical treatments to surface waters may also affect groundwater through leaching, translocation, or interchange.

Practices Develop site-specific BMP prescriptions for the following practices, as appropriate or when required, using State BMPs, Forest Service regional guidance, land management plan direction, BMP monitoring information, and professional judgment.

- Coordinate project with State water quality and fish and wildlife agencies as necessary.
- Use chemicals registered for application in aquatic systems.
- Use the minimum concentration of chemicals required to be reasonably certain that treatment objectives would be met.
 - ┆ Consider physical attributes of the waterbody, water flow and turbulence, waterbody mixing time, water chemistry, target species, label directions, percentage of active ingredient in the formulation to be used, application method, and project objectives to determine chemical concentration to use.
 - ┆ Follow label directions near critical points such as water intakes or, if label is silent on this issue, consider using lower concentrations or nontreatment buffers.
 - ┆ Consider using pretreatment bioassay tests to determine if the recommended concentration will be effective to meet treatment objectives.
 - ┆ Adjust chemical concentration and application methods to account for the effect of thermal stratification in lakes or reservoirs to achieve treatment objectives.
 - ┆ Adjust chemical concentration and application methods in streams and flowing water to account for the effect that any barriers, diversion structures, beaver dams, seeps, springs, and tributaries may have on chemical dilution and mixing to achieve treatment objectives.
- Avoid applying chemicals in situations where they could enter nontarget waters.
- Determine the need to treat tributaries to standing waterbodies to meet treatment objectives.
 - ┆ Apply chemical treatment to tributaries before treating the standing waterbody.
- Determine the need for neutralization of chemicals applied directly to water.
 - ┆ Evaluate the environmental advantages and disadvantages of natural degradation compared to the use of neutralizing agents.

- Use neutralization agents when the chemical treatment effects would cause unacceptable downstream impacts without intervention.
 - For neutralization of flowing water, determine a neutralization zone (e.g., mixing zone) based on time of travel below the application point where potential flora or fauna mortality can be expected before the chemical is completely neutralized.
- Determine the need for collecting dead flora or fauna.
 - Dispose of dead flora or fauna in an approved manner that does not adversely affect water quality.
- Monitor water quality and sediments pre- and post-chemical treatment at representative locations to evaluate relevant water chemistry and chemical concentrations (see BMP Chem-6 [Chemical Application Monitoring and Evaluation]).
- Implement the pesticide spill contingency plan elements within the project safety plan if a spill occurs (FSH 2109.14, chapter 60).

Chem-5. Chemical Handling and Disposal

Manual or Handbook

Reference FSH 2109.14, chapter 40.

Objective Avoid or minimize water and soil contamination when transporting, storing, preparing and mixing chemicals; cleaning application equipment; and cleaning or disposing chemical containers.

Explanation Handling chemicals, chemical containers, and equipment can lead to contamination of surface water or groundwater if not done carefully. Spills, leaks, or wash water can contaminate soil and leach into groundwater. Residue left on containers or equipment can wash off during precipitation events and enter surface waters. Preparing and mixing chemicals and cleaning and disposing of chemical containers must be done in accordance with Federal, State, and local laws, regulations, and directives. Specific procedures are documented in the Forest Service Pesticide Use Management and Coordination Handbook (FSH 2109.14, chapter 40) as well as in State and local laws.

Practices Develop site-specific BMP prescriptions for the following practices, as appropriate or when required, using State BMPs, Forest Service regional guidance, land management plan direction, BMP monitoring information, and professional judgment.

- Transport and handle chemical containers in a manner that minimizes the potential for leaks and spills.
 - Inspect containers for leaks or loose caps or plugs before loading.
 - Secure containers properly to avoid or minimize shifting in transport.
 - Check containers periodically enroute.
 - Ensure arrangements for proper storage are in place before transporting chemicals.
- Manage and store chemicals in accordance with all applicable Federal, State, or local regulations, including label directions.
 - Store chemicals in their original containers with labels intact.
 - Locate chemical storage facilities at sites that minimize the possibility of impacts to surface water or groundwater in case accidents or fires occur.
 - At a minimum, ensure that containment of a complete spill from the largest container being stored is possible with the spill-kit materials at the storage site.

- Check containers before storage and periodically during storage to ensure that they are properly sealed and not leaking.
- Locate operation bases in appropriate sites where possible spills would not enter surface waterbodies or groundwater aquifers.
- Ensure that mixing equipment, containers, and spill kits are in place and adequate for the project size and chemicals to be used.
- Follow label directions; applicable Federal, State, and local laws; and Forest Service direction for proper preparation and mixing of chemicals and cleaning and disposal of chemical materials and equipment.
 - When a contractor supplies the pesticide, the contractor is responsible for proper chemical preparation and mixing and container cleaning and disposal in accordance with label directions and Federal, State, and local laws.
 - Apply rinse water from empty chemical containers, mixing apparatus, and equipment clean up to the treatment area, not into the ground near streams.
 - Provide water from off site for cleaning equipment and application personnel rather than using onsite surface waters.
- Inspect application equipment to ensure that chemicals will not leak and the application prescription can be achieved.
- Implement the chemical spill contingency plan elements within the project safety plan if a spill occurs (FSH 2109.14, chapter 60).

Chem-6. Chemical Application Monitoring and Evaluation

Manual or Handbook

Reference FSM 2150.1; FSH 2109.14, chapter 50.

- Objectives**
1. Determine whether chemicals have been applied safely, have been restricted to intended targets, and have not resulted in unexpected nontarget effects.
 2. Document and provide early warning of possible hazardous conditions resulting from potential contamination of water or other nontarget resources or areas by chemicals.

Explanation Monitoring of chemical applications is used to evaluate and document chemical application accuracy, amount, and effects on soils and water quality to reduce or eliminate hazards to nontarget biological or physical resources. Monitoring can occur before, during, and after chemical application depending on treatment objectives and monitoring questions. Monitoring methods may include any of the following: visual observations; vegetation surveys; use of spray cards; dye tracing (fluorometry); and sampling of water, soil, sediment, flora, or fauna to measure chemical presence in or near water. Monitoring needs and methods are determined in the project planning process and should consider treatment objectives; resource values at risk; chemical properties; potential for offsite movement; Federal, State, and local requirements; monitoring costs; and available project funding.

Practices Develop site-specific BMP prescriptions for the following practices, as appropriate or when required, using State BMPs, Forest Service regional guidance, land management plan direction, BMP monitoring information, and professional judgment.

- Identify the following elements in all water resource monitoring plans and specify the rationale for each:
 - What are the monitoring questions?

-
- Who will be involved and what are their roles and responsibilities?
 - What parameters will be monitored and analyzed?
 - When and where will monitoring take place?
 - What methods will be used for sampling and analyses?
 - How will Chain of Custody requirements for sample handling be met?
 - What are the criteria for quality assurance and quality control?
 - Consider the following factors when developing monitoring questions:
 - The physical or biological resource of concern, including human health.
 - Applicable Federal, State, and local laws and regulations.
 - Type of chemical.
 - Type of application equipment used and method of application.
 - Site-related difficulties that affect both application and monitoring.
 - Public concerns.
 - Potential benefits of the application.
 - Availability of analytic methods, detection limits, tools, and laboratories.
 - Costs of monitoring and resources available to implement monitoring plan.
 - Choose monitoring methods and sample locations suitable to address the monitoring questions.
 - Consider the need to take random batch or tank samples for future testing in the event of treatment failure or an unexpected adverse effect.
 - Monitor sensitive environments during and after chemical applications to detect and evaluate unanticipated events.
 - Use U.S. Environmental Protection Agency-certified laboratories for chemical sample analysis.
 - Use appropriate containers, preservation, and transportation to meet Standard Methods requirements.
 - Implement proper Chain of Custody procedures for sample handling.
 - Evaluate and interpret the results of monitoring in terms of compliance with, and adequacy of, treatment objectives and specifications.

Resources for Chemical Use Management Activities

Aquatic Pesticides Finlayson, B.J.; Schnick, R.A.; Cailteux, R.L.; DeMong, L.; and others. 2000. Rotenone use in fisheries management. 214 p. Available at http://www.fisheriessociety.org/rotenone/Rotenone_Manual.pdf.

Netherland, M.D. 2009. Chapter 11. Chemical control of aquatic weeds, pp. 65-78. In: Gettys, L.A.; Haller, W.T.; Bellaud, M., eds. Biology and control of aquatic plants: a best management practices handbook. Marietta, GA: Aquatic Ecosystem Restoration Foundation. 210 p. Available at <http://www.aquatics.org/bmp.htm>.

-
- Dye Tracers** Kilpatrick, F.A.; Cobb, E.D. 1985. Measurement of discharge using tracers. TWI 03-A16. Reston, VA: U.S. Department of the Interior, U.S. Geological Survey (USGS). p. 52. Available at http://smig.usgs.gov/SMIG/tracer_methods.html.
- Kilpatrick, F.A.; Wilson, J.F., Jr. 1989. Measurement of time of travel in streams by dye tracers. TWI 03-A9. Reston, VA: U.S. Department of the Interior, USGS. p. 27. Available at http://smig.usgs.gov/SMIG/tracer_methods.html.
- Wilson, J.F. Jr.; Cobb, E.D.; Kilpatrick, F.A. 1986. Fluorometric procedures for dye tracing. TWI 03-A12. Reston, VA: U.S. Department of the Interior, USGS. p. 34. Available at http://smig.usgs.gov/SMIG/tracer_methods.html.
- Monitoring** Alvarez, D.A. 2010. Guidelines for the use of the semipermeable membrane device (SPMD) and the polar organic chemical integrative sampler (POCIS) in environmental monitoring studies. TM 1–D4. Reston, VA: U.S. Department of the Interior, USGS. 28 p. Available at <http://pubs.usgs.gov/tm/tm1d4/>.
- MacDonald, L.H.; Smart, A.W.; Wissmar, R.C. 1991. Monitoring guidelines to evaluate effects of forestry activities on streams in the Pacific Northwest and Alaska. EPA 910/9-91-001. Seattle, WA: U.S. Environmental Protection Agency and University of Washington. 166 p.
- Oregon Plan for Salmon and Watersheds, Water Quality Monitoring Team. 1999. Chapter 13—Pesticides and toxins protocol. P. 13-1 – 13-10. In: Water quality monitoring: technical guidebook version 2.0. Available at http://oregon.gov/OWEB/docs/pubs/wq_mon_guide.pdf.
- Risk Assessments** U.S. Department of Agriculture, Forest Service, Forest Health Protection, Pesticide Management and Coordination. Human health and ecological risk assessments. Washington, DC. Available at <http://www.fs.fed.us/foresthealth/pesticide/risk.shtml>.
- Silvicultural Chemicals** Holaday, S. and Wagner, C. 2010. Chapter 10—Chemicals. In: Wisconsin’s forestry best management practices for water quality: Field manual for loggers, landowners and land managers. Pub. FR-093. Madison, WI: Wisconsin Department of Natural Resources, Division of Forestry. 163 p. Available at <http://dnr.wi.gov/topic/forestmanagement/bmp.html>.
- Michael, J.L. 2004. Best management practices for silvicultural chemicals and the science behind them. Water, Air and Soil Pollution: Focus 4: 95–117. Available at http://ncrs.fs.fed.us/fmg/nfmg/docs/bmp_chemical.pdf.
- Newton, M.; Norgren, J.A. 1977. Silvicultural chemicals and protection of water quality. EPA 910/9-77-036. Seattle, WA: U.S. Environmental Protection Agency. Available at <http://www.epa.gov/nscep/index.html>.
- U.S. Environmental Protection Agency, Office of Water. 2005. Chapter 3I: Forest chemical management. p. 3-99 – 3-106. In: National management measures to control nonpoint source pollution from forestry. EPA 841-B-05-001. Washington, DC. Available at <http://www.epa.gov/owow/nps/forestrygmt/>.

Facilities and Nonrecreation Special Uses Management Activities

The purpose of this set of Best Management Practices (BMPs) is to avoid, minimize, or mitigate adverse effects to soil, water quality, and riparian resources that may result from development, use, maintenance, and reclamation of facilities located on National Forest System (NFS) lands. Facilities include buildings, camps, towers, pipelines, stream gauging stations, water storage and conveyance facilities, or other permanent or semipermanent structures and infrastructure associated with Forest Service-administered facilities. Forest Service facilities normally encountered on NFS lands include fire stations, work centers, permanent field camps, ranger stations, visitor centers, public water systems, and sanitation systems. Other facilities on NFS lands may be operated by the private sector through easements or special use authorizations. Examples of these third-party facilities include work and organizational camps, concession sites, electronic and communication sites, public water and sanitation systems, power transmission lines, pipelines, research equipment and structures, and access routes to private land in-holdings.

Ten National Core BMPs are in the Facilities and Nonrecreation Special Uses Management Activities category. These BMPs are to be used in all facilities and nonrecreation special use authorizations on NFS lands. BMP Fac-1 (Facilities and Nonrecreation Special Uses Planning) is a planning BMP for facilities and nonrecreation special uses projects. BMP Fac-2 (Facility Construction and Stormwater Control) provides direction for erosion control and stormwater management during construction activities. This BMP applies to any ground-disturbing activity, regardless of the resource category; for example, constructing a campground, operating a mine, or reconstructing a road. BMP Fac-3 (Potable Water Supply Systems), BMP Fac-4 (Sanitation Systems), and BMP Fac-5 (Solid Waste Management) provide practices for drinking water, human sanitation, and trash or garbage disposal at facilities. BMP Fac-6 (Hazardous Materials) covers management of hazardous materials and applies to any activity that involves hazardous materials, not just at facilities. BMP Fac-7 (Vehicles and Equipment Wash Water) covers vehicle washing, which usually takes place at a facility. BMP Fac-8 (Nonrecreation Special Use Authorizations) and BMP Fac-9 (Pipelines, Transmission Facilities, and Rights-of-Way) provide practices for third-party uses on NFS lands that are not related to recreation activities. BMP Fac-10 (Facility Site Reclamation) provides direction for reclamation of developed sites that are no longer needed for their developed purposes.

States will be used in the rest of this resource category to signify both States and those tribes that have received approval from the U.S. Environmental Protection Agency (EPA) for treatment as a State under the Clean Water Act (CWA).

Facilities and Nonrecreation Special Uses BMPs	
Fac-1	Facilities and Nonrecreation Special Uses Planning
Fac-2	Facility Construction and Stormwater Control
Fac-3	Potable Water Supply Systems
Fac-4	Sanitation Systems
Fac-5	Solid Waste Management
Fac-6	Hazardous Materials
Fac-7	Vehicle and Equipment Wash Water
Fac-8	Nonrecreation Special Use Authorizations
Fac-9	Pipelines, Transmission Facilities, and Rights-of-Way
Fac-10	Facility Site Reclamation

Fac-1. Facilities and Nonrecreation Special Uses Planning

Manual or Handbook

Reference Forest Service Handbook (FSH) 7309.11, chapter 20; FSH 7409.11, chapter 10; FSH 2709.11, chapter 50.

Objective Use the applicable special use authorization and administrative facilities planning processes to develop measures to avoid, minimize, or mitigate adverse effects to soil, water quality, and riparian resources during construction and operation of facilities and nonrecreation special uses activities.

Explanation Facilities may be developed on NFS lands by the Forest Service for a variety of administrative and recreational purposes. Potential effects of the proposed facility construction and operation on water quality should be considered when new sites are created or existing sites are improved and operated. In the planning process, site-specific BMP prescriptions are developed to avoid, minimize, or mitigate adverse effects to soil, water quality, and riparian resources.

Facilities developed and operated by others on NFS lands are administered through special use authorizations issued by the Forest Service to public or private agencies, a group, or an individual. Special use permits must include terms and conditions to protect the environment and otherwise comply with the requirements of the Federal Land Policy and Management Act of 1976 (43 U.S.C. 1752). These environmental protection requirements include the use of appropriate BMPs to control nonpoint source pollution.

State and local governments regulate many activities associated with facility development and operation, such as public water supplies, sanitation systems, waste disposal, and control of stormwater discharges. State or local requirements applicable to these activities should be incorporated into facility design, construction, and operation plans, and terms and conditions during the planning process.

Practices Develop site-specific BMP prescriptions for the following practices, as appropriate or when required, using State BMPs, Forest Service regional guidance, land management plan direction, BMP monitoring information, and professional judgment.

- Use applicable practices of BMP Plan-2 (Project Planning and Analysis) and BMP Plan-3 (Aquatic Management Zone [AMZ] Planning) when planning facilities or nonrecreation special use projects.
- Consider the following design criteria in facility planning.
 - Locate the facility away from the immediate vicinity of surface waters, AMZs, wetlands, sandy soils, shallow water tables, groundwater recharge areas, floodplains, and other sensitive areas to the extent practicable.
 - Avoid unstable slopes and soils.
 - Minimize the disturbance footprint.
 - Use and maintain proper erosion and sediment control practices during and immediately after construction activities (See BMP Fac-2 [Facility Construction and Stormwater Control]).
 - Incorporate suitable stormwater controls in the project design (See BMP Fac-2 [Facility Construction and Stormwater Control]).
 - Use applicable Road Management BMPs for access roads associated with facility sites.
 - Incorporate requirements from applicable Federal, State, and local permits into facility construction and operation plans.

- Consider the time necessary to complete facility development activities.
 - Develop a contingency plan for implementing appropriate prestorm or winterization BMPs before the grading permit expires.
- Determine the design capacity, if applicable, of the site for public or administrative use, considering needs for protecting soil, water quality, and riparian resources.
 - Ensure that the capacity of the site matches the ability of the site to withstand the use.
- Conform to all applicable Federal, State, and local regulations and permits governing water supply, sanitation, and underground injection systems (see BMP Fac-3 [Potable Water Supply Systems] and BMP Fac-4 [Sanitation Systems]).
- Determine instream flow needs to minimize damage to scenic and aesthetic values; native plant, fish, and wildlife habitat; and to otherwise protect the environment where the operation of the facility would modify existing streamflow regimes (See BMP WatUses-1 [Water Uses Planning]).

Fac-2. Facility Construction and Stormwater Control

Manual or Handbook

Reference None known.

Objective Avoid, minimize, or mitigate adverse effects to soil, water quality, and riparian resources by controlling erosion and managing stormwater discharge originating from ground disturbance during construction of developed sites.

Explanation During construction and operation of facility sites, land may be cleared of existing vegetation and ground cover, exposing mineral soil that may be more easily eroded by water, wind, and gravity. Changes in land use and impervious surfaces can temporarily or permanently alter stormwater runoff that, if left uncontrolled, can affect morphology, stability, and quality of nearby streams and other waterbodies. Erosion and stormwater runoff control measures are implemented to retain soil in place and to control delivery of suspended sediment and other pollutants to nearby surface water. This practice is initiated during the planning phase and applied during project implementation and operation.

This BMP contains practices for managing erosion and stormwater discharge that are generally applicable for any project that involves ground disturbance, including developed recreation, mineral exploration and production sites, pipelines, water developments, etc., and should be used for all such projects.

Practices Develop site-specific BMP prescriptions for the following practices, as appropriate or when required, using State BMPs, Forest Service regional guidance, land management plan direction, BMP monitoring information, and professional judgment.

- Obtain Clean Water Act (CWA) 402 stormwater discharge permit coverage from the appropriate State agency or the U.S. Environmental Protection Agency (EPA) when more than 1 acre of land will be disturbed through construction activities.
- Obtain CWA 404 permit coverage from the U.S. Army Corps of Engineers when dredge or fill material will be discharged to waters of the United States.
- Establish designated areas for equipment staging, stockpiling materials, and parking to minimize the area of ground disturbance (see BMP Road-9 [Parking Sites and Staging Areas] and BMP Road-10 [Equipment Refueling and Servicing]).

-
- Establish and maintain construction area limits to the minimum area necessary for completing the project and confine disturbance to within this area.
 - Develop and implement an erosion control and sediment plan that covers all disturbed areas, including borrow, stockpile, fueling, and staging areas used during construction activities.
 - Calculate the expected runoff generated using a suitable design storm to determine necessary stormwater drainage capacity.
 - Use site conditions and local requirements to determine design storm.
 - Include run-on from any contributing areas.
 - Refer to State or local construction and stormwater BMP manuals, guidebooks, and trade publications for effective techniques to:
 - Apply soil protective cover on disturbed areas where natural revegetation is inadequate to prevent accelerated erosion during construction or before the next growing season.
 - Maintain the natural drainage pattern of the area wherever practicable.
 - Control, collect, detain, treat, and disperse stormwater runoff from the site.
 - Divert surface runoff around bare areas with appropriate energy dissipation and sediment filters.
 - Stabilize steep excavated slopes.
 - Develop and implement a postconstruction site vegetation plan using suitable species and establishment techniques to revegetate the site in compliance with local direction and requirements per Forest Service Manual (FSM) 2070 and FSM 2080 for vegetation ecology and prevention and control of invasive species.
 - Install sediment and stormwater controls before initiating surface-disturbing activities to the extent practicable.
 - Do not use snow or frozen soil material in facility construction.
 - Schedule, to the extent practicable, construction activities to avoid direct soil and water disturbance during periods of the year when heavy precipitation and runoff are likely to occur.
 - Limit the amount of exposed or disturbed soil at any one time to the minimum necessary to complete construction operations.
 - Limit operation of equipment when ground conditions could result in excessive rutting, soil puddling, or runoff of sediments directly into waterbodies.
 - Install suitable stormwater and erosion control measures to stabilize disturbed areas and waterways before seasonal shutdown of project operations or when severe or successive storms are expected.
 - Use low-impact development practices where practicable.
 - Maintain erosion and stormwater controls as necessary to ensure proper and effective functioning.
 - Prepare for unexpected failures of erosion control measures.
 - Implement corrective actions without delay when failures are discovered to prevent pollutant discharge to nearby waterbodies.
 - Routinely inspect construction sites to verify that erosion and stormwater controls are implemented and functioning as designed and are appropriately maintained.
 - Use suitable measures in compliance with local direction to prevent and control invasive species.

Fac-3. Potable Water Supply Systems

Manual or Handbook

Reference Manual or Handbook Reference: FSM 7420 and FSH 7409.11, chapter 40.

Objective Provide potable water supplies of sufficient quality and quantity to support the use at facilities.

Explanation Many facilities provide potable water from a surface water or groundwater source. Water systems should supply an adequate volume of acceptably clean water as needed by the facility. A water system is comprised of collection, treatment, storage, and distribution facilities. Water systems are classified into categories (e.g., public versus nonpublic, community versus noncommunity, and transient versus nontransient) based on ownership, size, and permanence of the population served. Regulations are based on these different categories. Management requirements and controls to protect drinking water quality and provide potable water are incorporated into each facility's operation and maintenance plan (FSM 7410).

Practices Develop site-specific BMP prescriptions for the following practices, as appropriate or when required, using State BMPs, Forest Service regional guidance, land management plan direction, BMP monitoring information, and professional judgment.

- Develop water systems only in places where the water source can be protected.
- Develop groundwater wells and facilities in a manner that reduces the potential of groundwater aquifer contamination in accordance with BMP WatUses-2 (Water Wells for Production and Monitoring).
- Use applicable practices of BMP WatUses-3 (Administrative Water Developments) and BMP WatUses-4 (Water Diversions and Conveyances) to manage surface diversions.
- Operate, monitor, and manage Forest Service-owned (public and nonpublic) drinking water systems in accordance with direction in FSM 7420.
 - Design, construct, operate, and maintain water systems in a manner that provides for physical protection of the water source and system.
 - Treat water as necessary to achieve desired water quality.
 - Conduct sanitary and condition surveys per required schedules.
 - Implement follow-up actions identified in the sanitary and condition surveys.
 - Minimize possible contaminating activities within Wellhead Protection Areas and Source Water Assessment Areas to protect drinking water sources.
 - Conduct required system monitoring and follow-up actions as needed.
- Perform water supply and system disinfection activities in a manner such that disinfectant residuals and byproducts will not affect nearby surface water or groundwater.
- Ensure that permit holder-owned and other authorized drinking water systems on NFS lands are operated and maintained according to direction in FSM 7423.

Fac-4. Sanitation Systems

Manual or Handbook

Reference FSM 2330; FSM 7430; and FSH 7409.11, chapter 50.

Objective Avoid, minimize, or mitigate adverse effects to soil and water quality from bacteria, nutrients, and other pollutants resulting from collection, transmission, treatment, and disposal of sewage and wastewater at facilities.

Explanation Sanitation systems at facilities vary from a portable toilet to a sophisticated treatment plant. Facilities also may have wastewater systems for showers and washbasins. The type of sanitation system at a facility depends on the purpose and capacity of the site, available and needed infrastructure, Forest Service policy, and State or local regulations. Bacteria, nutrients, and other contaminants from sanitation systems can enter surface water or groundwater if the system is not properly designed and operated. Facilities are required to comply with State and local public health and sanitation ordinances. Management requirements and controls to minimize the possibility of water contamination from wastewater collection, treatment, and disposal are incorporated into each facility's operation and maintenance plan (FSM 7410).

Practices Develop site-specific BMP prescriptions for the following practices, as appropriate or when required, using State BMPs, Forest Service regional guidance, land management plan direction, BMP monitoring information, and professional judgment.

- Use qualified personnel to locate, design, inspect, operate, maintain, and manage sanitation systems.
- Coordinate all phases of sanitation system management (planning, design, installation, inspection, operation, and maintenance) with appropriate State and local agencies to ensure compliance with applicable regulations.
- Design and operate waste collection, treatment, and disposal systems appropriate for the type and volume of waste generated at the site consistent with direction in FSH 7409.11, chapter 50.
- Follow applicable regulations and guidelines when locating toilets, wastewater disposal, and leach fields.
 - ┆ Use suitable setback distances from water bodies or other sensitive areas when siting facilities.
 - ┆ Use proper field investigations and soil tests to determine suitable soils for onsite treatment and disposal systems.
- Prepare and maintain an operation and maintenance plan for all waste treatment or disposal facilities (FSM 7410).
 - ┆ Inspect vaults, septic tanks, and other wastewater systems at regular intervals to ensure that capacities are not exceeded and that the system is functioning properly and in compliance with applicable State and local regulations.
 - ┆ Implement follow-up actions identified in the inspections as needed to ensure that the system is working properly.
 - ┆ Include procedures in operation and maintenance plans to contain or avoid releases of pollutants in floods or other emergencies.
- Ensure that permit holder-owned and other authorized sanitation systems on NFS lands are operated and maintained according to applicable regulations and direction.

-
- ↳ Consider changes or improvements to existing sanitary systems that may be causing water quality impacts, such as poorly located pit toilets or drain fields, at opportune times such as facility remodeling or change in facility ownership or control.

Fac-5. Solid Waste Management

Manual or Handbook

Reference FSM 2130; FSM 7460; and FSH 7409.11, chapter 80.

Objective Avoid, minimize, or mitigate adverse effects to water quality from trash, nutrients, bacteria, and chemicals associated with solid waste management at facilities.

Explanation Uncollected garbage and trash at developed facilities can contaminate water by introducing nutrients, bacteria, or chemicals to the water. Trash can be blown about by the wind or carried by runoff into waterbodies. In addition, uncollected garbage can attract wildlife, which are looking for an easy meal, to the facility.

Practices Develop site-specific BMP prescriptions for the following practices, as appropriate or when required, using State BMPs, Forest Service regional guidance, land management plan direction, BMP monitoring information, and professional judgment.

- Develop a Solid Waste System consistent with direction in FSM 7460 and FSH 7409.11, chapter 80 that defines and describes collection, transportation, storage, and final disposal methods for solid waste generated at facilities.
- Use suitable public relations and information tools and enforcement measures to encourage the public to use proper solid waste disposal measures.
 - ↳ Encourage recycling of materials where practicable.
 - ↳ Encourage the public to “pack it in-pack it out” in areas where practicable.
- Provide receptacles for trash at developed facilities.
 - ↳ Place trash and recycling receptacles in areas that are convenient to the facility’s users.
 - ↳ Place trash and recycling receptacles in locations away from waterbodies.
 - ↳ Provide receptacles that discourage wildlife foraging as suitable for the area (e.g., bears, raccoons, birds) and suitably confine materials until collected.
 - ↳ Collect trash on a routine schedule to prevent the receptacles from overflowing.
- Dispose of collected garbage at properly designed and operated municipal-, county-, or State-authorized sanitary landfills or waste recycling sites where groundwater and surface water are adequately protected.
- Obtain necessary State or local permits for solid waste disposal sites.

Fac-6. Hazardous Materials

Manual or Handbook

Reference 40 CFR 112; FSM 2160; and FSH 2109.14, chapter 60.

Objective Avoid or minimize short- and long-term adverse effects to soil and water resources by preventing releases of hazardous materials.

Explanation Constructing and operating facilities often involve the storage and use of hazardous materials. Improper storage and use can contaminate nearby soils and surface water or groundwater resources.

Practices Develop site-specific BMP prescriptions for the following practices, as appropriate or when required, using State BMPs, Forest Service regional guidance, land management plan direction, BMP monitoring information, and professional judgment.

- Ensure that all employees involved in the use, storage, transportation, and disposal of hazardous materials receive proper training.
- Limit the acquisition, storage, and use of hazardous, toxic, and extremely hazardous substances to only those necessary and consistent with mission requirements.
- Manage the use, storage, discharge, or disposal of pollutants and hazardous or toxic substances generated by the facility in compliance with applicable regulations and requirements.
- Monitor underground storage tanks and promptly address leaking tanks in consultation with the proper officials at State and Federal regulatory agencies.
- Construct and install new tanks in accordance with Federal, State, and local regulations.
 - Ensure that existing tanks meet performance standards for new tanks, meet upgrade requirements, or are taken out of service.
- Prepare a certified Spill Prevention Control and Countermeasure (SPCC) Plan for each facility as required by 40 CFR 112.
 - Install or construct the containment features or countermeasures called for in the SPCC Plan to ensure that spilled hazardous materials are contained and do not reach groundwater or surface water.
 - Ensure that cleanup of spills and leaking tanks is completed in compliance with Federal, State, and local regulations and requirements.
- Respond to hazardous materials releases or spills using the established site-specific contingency plan for incidental releases and the Emergency Response Plan for larger releases.
 - Train employees to understand these plans; the materials involved; and their responsibilities for safety, notification, containment, and removal.
 - Provide adequate communication to all downstream water users, such as municipal drinking water providers and fish hatcheries, as necessary.
- Ensure that hazardous spill kits are adequately stocked with necessary supplies and are maintained in accessible locations.

Fac-7. Vehicle and Equipment Wash Water

Manual or Handbook

Reference None known.

Objective Avoid or minimize contamination of surface water and groundwater by vehicle or equipment wash water that may contain oil, grease, phosphates, soaps, road salts, other chemicals, suspended solids, and invasive species.

Explanation Washing vehicles and equipment is a common method used to maintain vehicles and minimize the spread of noxious and invasive species. Wash water and the resulting residue removed from vehicles and equipment may contain oils, chemicals, or sediment harmful to water and aquatic resources if not properly contained and treated. Work centers, ranger stations, fire stations, and other

facilities may have washing equipment and locations designated for cleaning fleet or contracted vehicles and equipment. Temporary wash locations may also be installed during incident management or project work.

- Practices** Develop site-specific BMP prescriptions for the following practices, as appropriate or when required, using State BMPs, Forest Service regional guidance, land management plan direction, BMP monitoring information, and professional judgment.
- Use commercial washing facilities that have proper wastewater treatment systems whenever possible.
 - Maintain a list of appropriate wash stations in the local area and provide the list to local offices, permit holders, and contractors.
 - Install temporary wash sites only in areas where the water and residue can be adequately collected and either filtered on site or conveyed to an appropriate wastewater treatment facility.
 - Consider the use of a portable vehicle washer system, such as that designed by the Missoula Technology and Development System, to contain and filter the wash water.
 - Locate temporary wash sites out of AMZs, wetlands, groundwater recharge areas, floodplains, and other environmentally sensitive areas.
 - Use suitable measures to treat and infiltrate wash water to comply with applicable surface water and groundwater protection regulations.

Fac-8. Nonrecreation Special Use Authorizations

Manual or Handbook

Reference FSM 2720 and FSH 2709.11, chapters 40 and 50.

Objective Avoid, minimize, or mitigate adverse effects to soil, water quality, and riparian resources from physical, chemical, and biological pollutants resulting from activities under nonrecreation special use authorizations.

Explanation This BMP covers all nonrecreation special use activities with the exceptions of pipelines; transmission facilities and other rights-of-ways; and water diversions, storage, and conveyance. BMP Fac-9 (Pipelines, Transmission Facilities, and Rights-of-Way), BMP WatUses-4 (Water Diversions and Conveyances), and BMP WatUses-5 (Dams and Impoundments) are provided for those activities.

The Forest Service role in defining and requiring the use of BMPs occurs during the development of the special use authorization and administration of the use. Discussions between the Forest Service and the permit holder concerning soil, water quality, and riparian resource impacts and appropriate BMPs to use should occur at the time of permit development or renewal. The special use authorization operation and maintenance plan details the conditions that must be met, including management requirements and mitigation measures to protect water quality. The permit holder will be required to conform to all applicable Federal, State, and local regulations and land management plan direction governing water resource protection and sanitation. State or Federal law may require that the permit holder obtain a pollution discharge permit or other authorization from a State, regional, or local government entity. Authorized uses often cover a wide range of activities and may require that BMPs from several management activity categories be included in the authorization.

Practices Develop site-specific BMP prescriptions for the following practices, as appropriate or when required, using State BMPs, Forest Service regional guidance, land management plan direction, BMP monitoring information, and professional judgment.

- Include in the authorization operation and maintenance plan the appropriate BMPs to control nonpoint source pollution from ground-disturbing activities, chemical use, and other activities that may adversely affect the physical, chemical, or biological integrity of surface water or groundwater.
- Update existing special use authorizations and operation and maintenance plans during annual renewal, or the next renewal, to be consistent with current requirements.
- Administer authorizations per the direction in FSM 2720 and FSH 2709.11 to ensure that water quality related terms and conditions are met.

Fac-9. Pipelines, Transmission Facilities, and Rights-of-Way

Manual or Handbook

Reference FSM 2726 and FSH 2709.11, chapter 50.

Objective Avoid, minimize, or mitigate adverse effects to soil, water quality, and riparian resources during the construction and maintenance of pipelines, powerlines, transmission facilities, and other rights-of-way.

Explanation Powerlines and pipelines are constructed on NFS land by both public and private agencies under either an easement or special use authorization. Impacts to soil and water resources during transmission corridor and pipeline construction and maintenance include those originating from directional drilling, pipeline testing, soil disturbance, and erosion associated with vegetation removal and road construction. Other water quality impacts could occur from natural events, inappropriate or unauthorized activities, chemical spills, herbicide use, and other maintenance activities.

Measures to avoid, minimize, or mitigate adverse effects to soil, water quality, and riparian resources should be incorporated in the authorization terms and conditions, project plans for construction and design, and the right-of-way management plans for ongoing maintenance of vegetation along the corridor.

Practices Develop site-specific BMP prescriptions for the following practices, as appropriate or when required, using State BMPs, Forest Service regional guidance, land management plan direction, BMP monitoring information, and professional judgment.

- Consider soil and water impacts from factors such as stream head cutting and channel expansion, stream crossings, slope stability and steepness, and amount of riparian area, floodplain, and wetland acreage to be disturbed when determining corridor location.
 - ┆ Co-locate pipelines and transmission lines with roads or their rights-of-way where practicable.
 - ┆ Limit corridor disturbance, particularly in or near AMZs, surface waters, shallow groundwater, unstable areas, hydric soils, or wetlands.
- Consider service road location and standards, type of construction equipment (wheeled, tracked, and helicopter), size and location of footings and guy anchors, and revegetation requirements during project design.
 - ┆ Use applicable BMPs for Mechanical Vegetation Management Activities when using mechanical treatments to remove vegetation from the project corridor.
 - ┆ Use applicable practices of BMP Road-2 (Road Location and Design) for planning access roads.

-
- Use applicable practices of BMP Fac-2 (Facility Construction and Stormwater Control), BMP Road-3 (Road Construction and Reconstruction), and BMP Road-7 (Stream Crossings) when constructing pipelines, powerlines, and transmission facilities and associated roads.
 - Use design and construction measures that sustain long-term wetland or stream function when a buried transmission line, pipeline, or tower support must be placed in a wetland or cross a stream (see BMP AqEco-2 [Operations in Aquatic Ecosystems]).
 - Use suitable measures for pipeline thickness, corrosion prevention, pipeline casing, cathodic protection and pipeline valves, and shut-off systems to prevent or minimize spills or leaks where pipelines cross waterbodies.
 - Require suitable and regular inspections, testing, and leak detection systems to identify and mitigate pipeline deformities and leaks.
 - Use applicable practices of BMP WatUses-3 (Administrative Water Developments) and BMP Min-7 (Produced Water) when obtaining or disposing of water used for hydraulic testing of pipelines on NFS lands.
 - Ensure that pipelines corridors, transmission lines, facilities, and other rights-of-ways are properly maintained to minimize damage to NFS resources in the event of an accident or natural disturbance.
 - Use applicable practices of BMP Fac-6 (Hazardous Materials), including preparation of an adequate Spill and Emergency Response Plan for pipelines carrying toxic or hazardous materials.
 - Use applicable BMPs for Mechanical Vegetation Management Activities when using mechanical treatments to manage vegetation within the corridor.
 - Use applicable BMPs for Chemical Use Activities when using chemicals for corridor maintenance or pipeline testing.
 - Use applicable practices of BMP Road-4 (Road Maintenance and Operations) for maintenance of access roads.
 - Aggressively address unauthorized uses of the corridor, such as motorized vehicle use, that are exposing soils, increasing erosion, or damaging the facilities.

Fac-10. Facility Site Reclamation

Manual or Handbook

Reference FSM 2020.

Objective Reclaim facilities and surrounding disturbed areas to as near to the predisturbed condition as is reasonably practicable following closure or completion of operations, or as necessary for mitigation purposes, to avoid, minimize, or mitigate long-term adverse effects to soil, water quality, and riparian resources.

Explanation Abandoned structures and wastes, particularly hazardous materials, at facility sites may pose a safety risk to the public. Lack of ongoing maintenance of facility sites can also threaten surface water and groundwater quality via erosion and chemical leaks as they fall into disrepair. Facility sites should be closed and reclaimed after the need for it ends or the recurrent impacts to resources indicate the site cannot be properly managed with available resources. Heavily used recreation sites will cause some areas to become denuded and compacted. These disturbed sites may become unstable and begin to erode at accelerated rates if not stabilized. Reestablishing stable grades, functional

drainages, some level of site infiltration capacity, and effective ground cover on terrestrial sites and stabilizing substrates impacted by water flow or wave action are necessary to rehabilitate disturbed areas to avoid or minimize water quality and riparian resource degradation. Disturbances in and immediately adjacent to surface waters, riparian areas, and wetlands should be the highest priority for reclamation or rehabilitation.

Practices

Develop site-specific BMP prescriptions for the following practices, as appropriate or when required, using State BMPs, Forest Service regional guidance, land management plan direction, BMP monitoring information, and professional judgment.

- Regularly review the need for and use of stockpiles, materials, supplies, and facilities.
- Surplus, repurpose, or recycle unneeded usable materials where practicable.
 - Dispose of unneeded materials through the appropriate solid waste handlers.
 - Consult the forest pollution prevention coordinator for proper disposal of hazardous materials.
- Develop and implement a reclamation plan to rehabilitate and restore, to the extent practicable, the natural ecological components, structures, and processes consistent with land management plan desired conditions, goals, and objectives at sites where structures or facilities have been permanently removed.
 - Remove unneeded structures.
 - Re-establish original slope contours, surface, and subsurface hydrologic pathways where practicable and as opportunities arise.
 - Improve infiltration capacity on compacted areas of the site.
 - Establish effective ground cover on disturbed sites to avoid or minimize accelerated erosion and soil loss.
 - Use suitable species and establishment techniques to revegetate the site in compliance with local direction and requirements per FSM 2070 and FSM 2080 for vegetation ecology and prevention and control of invasive species.
 - Stabilize disturbed streambed and banks (see BMP AqEco-4 [Stream Channels and Shorelines]).
 - Reconstruct or restore stream channels, wetlands, floodplains, and riparian areas to achieve desired conditions for aquatic ecosystem composition, structure, function, and processes (see BMP AqEco-3 [Ponds and Wetlands] and BMP AqEco-4 [Stream Channels and Shorelines]).
- Decommission unneeded roads, trails, and staging areas (see BMP Roads-6 [Road Storage and Decommissioning]).
- Consider long-term management of the site and nearby areas to promote project success.
 - Use suitable measures to limit human, vehicle, and livestock access to site as needed to allow for recovery of vegetation.

Resources for Facilities and Nonrecreation Special Uses Management Activities

- Low Impact Development** U.S. Environmental Protection Agency (EPA), Office of Water. Information and other resources on low impact development are available at <http://water.epa.gov/polwaste/green/index.cfm>.
- Sanitation** Cook, B. 1991. Guidelines for the selection of a toilet facility. 9123-1204. San Dimas, CA: U.S. Department of Agriculture (USDA), Forest Service, Technology and Development Program. 22 p. Available at <http://fsweb.sdtc.wo.fs.fed.us/pubs/pdfimage/91231204.pdf>.
- Otis, R.; Kreissl, J.; Frederick, R.; Goo, R.; Casey, P.; Tonning, B; et al. 2002. Onsite wastewater treatment systems manual. EPA 625-R-00-008. Washington, DC: EPA, Office of Water and Office of Research and Development. 367 p. Available at http://www.epa.gov/owm/septic/pubs/septic_2002_osdm_all.pdf.
- Stormwater** EPA, Office of Water. Website with national menu of stormwater BMPs. Available at <http://cfpub.epa.gov/npdes/stormwater/menuofbmps/index.cfm>.
- EPA, Office of Water. Website with stormwater pollution prevention plans for construction activities. Available at <http://cfpub.epa.gov/npdes/stormwater/swppp.cfm>.
- EPA, Region 10. Web site with State stormwater BMP manuals. Available at <http://yosemite.epa.gov/R10/WATER.NSF/0/17090627a929f2a488256bdc007d8dee?OpenDocument>.
- Water Environment Research Foundation; American Society of Civil Engineers; EPA; U.S. Department of Transportation, Federal Highways Administration; American Public Works Association. International stormwater BMP Database. Available at <http://www.bmpdatabase.org>.
- Waste Management** Sinclair, L. 1995. Animal resistant garbage containers. 9523 1205-SDTDC. San Dimas, CA: USDA Forest Service, Technology and Development Program. 38 p. Available at <http://fsweb.sdtc.wo.fs.fed.us/pubs/pdfimage/95231205.pdf>.
- Sinclair, L. 1999. Comprehensive waste management. 9923 1206-SDTDC. San Dimas, CA: USDA Forest Service, Technology and Development Program. 24 p. Available at <http://fsweb.sdtc.wo.fs.fed.us/pubs/pdf/99231206.pdf>.
- Water Systems** Land, B. 2006. Water system operator's guide. 0623-1802-SDTDC. San Dimas, CA: USDA Forest Service, Technology and Development Program. 100 p. Available at http://www.fs.fed.us/eng/pubs/pdf/waterguide/lo_res/06231802.pdf.
- Snodgrass, K. 2007. Water use in Forest Service recreation areas: Guidelines for water system designers. 0773-2326-MTDC. Missoula, MT: USDA Forest Service, Technology and Development Program. 10 p. Available at <http://fsweb.mtdc.wo.fs.fed.us/pubs/htmlpubs/htm07732326/index.htm>.

Wildland Fire Management Activities

The purpose of this set of Best Management Practices (BMPs) is to avoid, minimize, or mitigate adverse effects to soil, water quality, and riparian resources that may result from wildland fire management activities. Common wildland fire management operations include using prescribed fire, managing wildfire using a wide range of strategies from monitoring to aggressive control and suppression, and rehabilitating fire and suppression damage.

Firefighter and public safety is always the first priority in wildland fire activities. Implementation of BMPs to protect soil, water quality, and riparian resources, though important, must not compromise public or firefighter safety in wildland fire situations.

Four National Core BMPs are in the Wildland Fire Management Activities category. These BMPs are to be used during all wildfire management activities on National Forest System (NFS) lands. BMP Fire-1 (Wildland Fire Management Planning) is a planning BMP for wildland fire management at the land management-plan scale and at the project scale. BMP Fire-2 (Use of Prescribed Fire) provides direction for water quality protection during prescribed fire treatments. BMP Fire-3 (Wildland Fire Control and Suppression) provides guidance for avoiding or minimizing effects to soil, water quality, and riparian resources to the extent practicable during wildland fire suppression activities. BMP Fire-4 (Wildland Fire Suppression Damage Rehabilitation) has practices for rehabilitating fire lines, fire camps, staging areas, and burned areas.

States will be used in the rest of this resource category to signify both States and those tribes that have received approval from the U.S. Environmental Protection Agency (EPA) for treatment as a State under the Clean Water Act (CWA).

Wildland Fire Management BMPs	
Fire-1	Wildland Fire Management Planning
Fire-2	Use of Prescribed Fire
Fire-3	Wildland Fire Control and Suppression
Fire-4	Wildland Fire Suppression Damage Rehabilitation

Fire-1. Wildland Fire Management Planning

Manual or Handbook

Reference Forest Service Manual (FSM) 5120; FSM 5150; and Forest Service Handbook (FSH) 5109.19, chapter 50.

Objective Use the fire management planning process to develop measures to avoid, minimize, or mitigate adverse effects to soil, water quality, and riparian resources during wildland fire management activities.

Explanation Wildland fire is an essential ecological process and natural change agent for many vegetation communities and habitat types on NFS lands. The role of wildland fire is incorporated into the land management planning process through goals and objectives, desired conditions, standards, and guidelines in the land management plan. A forest or grasslands' fire management plan (FMP) describes the objectives and constraints to manage prescribed fires and wildfires within the context of the land management plan. The FMP is used to assist in developing the response to a wildland fire and is supplemented by operational plans.

Prescribed fire may be used to achieve a number of resource management objectives. These fires may occur across variously sized patches, from small slash piles to very large, landscape-scale broadcast burns. Properly planned and executed, these treatments can be very effective at managing natural resources while avoiding or minimizing adverse effects to soil, water quality, and riparian resources. A Prescribed Fire Burn Plan describes why the fire is needed, what the fire will accomplish, when conditions will permit achievement of desired effects, how specific fire application will occur, and how the progress and results will be monitored and evaluated. Soil and water protection objectives and measures should be written into the prescribed fire prescription.

Wildfires caused by natural ignition sources are managed to achieve a full range of land management plan objectives including protection and enhancement of resources. The decision to manage a wildfire for enhancement of resource objectives is made when the fire starts based on the objectives and constraints outlined in the land management plan. These fires cannot be planned beyond land management plan direction that determines areas where protection will be the only objective versus areas where enhancement of other resources may be considered as well. Watershed resource considerations may be incorporated into all wildfires, but objectives to manage the fire for beneficial effects may only be applied where authorized by the land management plan.

Practices Develop site-specific BMP prescriptions for the following practices, as appropriate or when required, using State BMPs, Forest Service regional guidance, land management plan direction, BMP monitoring information, and professional judgment.

Land Management Plans

- Consider the beneficial and adverse effects of wildland fire on water quality and watershed condition when developing desired conditions and goals for the plan area.
 - Identify areas where the adverse effects of unplanned wildland fire to water quality and watershed condition outweigh the benefits.
- Include plan objectives and strategies that allow the use of wildland fire where suitable to restore watershed conditions.
- Include design criteria, standards, and guidelines for fire management activities to avoid or minimize adverse effects to soil, water quality, and riparian resources (see BMP Fire-2 [Use of Prescribed Fire] and BMP Fire-3 [Wildland Fire Control and Suppression]).
- Consider the need to establish a network of permanent water sources in the plan area for fire control and suppression (see BMP WatUses-3 [Administrative Water Developments]).

Prescribed Fire Plan

- Use applicable practices of BMP Plan-2 (Project Planning and Analysis) and BMP Plan-3 (Aquatic Management Zone [AMZ] Planning) when planning prescribed fire treatments.
- Consider prescription elements and ecosystem objectives at the appropriate watershed scale to determine the optimum and maximum burn unit size, total burn area, burn intensity, disturbance thresholds for local downstream water resources, area or length of water resources to be affected, and contingency strategies.
 - Consider the extent, severity, and recovery of fire disturbance a watershed has experienced in the past to evaluate cumulative effects and re-entry intervals.
- Identify environmental conditions favorable for achieving desired condition or treatment objectives of the site while minimizing detrimental mechanical and heat disturbance to soil and water considering the following factors.

-
- Existing and desired conditions for vegetation and fuel type, composition, structure, distribution, and density.
 - Short- and long-term site objectives.
 - Acceptable fire weather parameters.
 - Desirable soil, duff, and fuel moisture levels.
 - Existing duff and humus depths.
 - Site factors such as slope and soil conditions.
 - Expected fire behavior and burn severity based on past burn experience in vegetation types in the project area.
 - Extent and condition of roads, fuel breaks, and other resource activities and values.
 - Develop burn objectives that avoid or minimize creating water-repellent soil conditions to the extent practicable considering fuel load, fuel and soil moisture levels, fire residence times, and burn intensity.
 - Use low-intensity prescribed fire on steep slopes or highly erodible soils when prescribed fire is the only practicable means to achieve project objectives in these areas.
 - Set target levels for desired ground cover remaining after burning based on slope, soil type, and risk of soil and hillslope movement.
 - Plan burn areas to use natural or in-place barriers that reduce or limit fire spread, such as roads, canals, utility rights-of-way, barren or low fuel hazard areas, streams, lakes, or wetland features, where practicable, to minimize the need for fireline construction.
 - Identify the type, width, and location of firebreaks or firelines in the prescribed fire plan.
 - Use fire initiation techniques, control methods, and access locations for ignition and control (holding versus escape conditions) that minimize potential effects to soil, water quality, and riparian resources.
 - Use prescribed fire in the AMZ only when suitable to achieve long-term AMZ-desired conditions and management objectives (see BMP Plan-3 [AMZ Planning]).

Fire-2. Use of Prescribed Fire

Manual or Handbook

Reference FSM 5140.

Objective Avoid, minimize, or mitigate adverse effects of prescribed fire and associated activities on soil, water quality, and riparian resources that may result from excessive soil disturbance as well as inputs of ash, sediment, nutrients, and debris.

Explanation Prescribed fire, while a useful tool to achieve resource management objectives, can affect watershed condition by consuming vegetation, dead woody debris, humus, and duff; removing protective ground cover; contributing to creation of water-repellent soil conditions; damaging physical and biological soil quality from excessive heat; and releasing nutrients and metals to runoff into nearby streams. A prescribed fire may burn at a range of intensities, leaving a mosaic of burn severities within the fire perimeter. Actions to control and contain the prescribed fire, such as fireline construction, can also adversely affect watershed condition by creating a ground disturbance.

A Prescribed Fire Burn Plan guides the management of a prescribed fire. This plan contains the technical specifications for managing the fire and protecting other resources. Fire managers review these plans before fire ignition, briefing field crewmembers on practices and locations prescribed to avoid or minimize adverse effects to soil, water quality, and riparian resources.

- Practices** Develop site-specific BMP prescriptions for the following practices, as appropriate or when required, using State BMPs, Forest Service regional guidance, land management plan direction, BMP monitoring information, and professional judgment.
- Conduct the prescribed fire in such a manner as to achieve the burn objectives outlined in the Prescribed Fire Plan (see BMP Fire-1 [Wildland Fire Management Planning]).
 - Locate access and staging areas near the project site but outside of AMZs, wetlands, and sensitive soil areas.
 - Keep staging areas as small as possible while allowing for safe and efficient operations.
 - Store fuel for ignition devices in areas away from surface water bodies and wetlands.
 - Install suitable measures to minimize and control concentrated water flow and sediment from staging areas.
 - Collect and properly dispose of trash and other solid waste.
 - Restore and stabilize staging areas after use (see BMP Veg-6 [Landings]).
 - Conduct prescribed fires to minimize the residence time on the soil while meeting the burn objectives.
 - Manage fire intensity to maintain target levels of soil temperature and duff and residual vegetative cover within the limits and at locations described in the prescribed fire plan.
 - Construct fireline to the minimum size and standard necessary to contain the prescribed fire and meet overall project objectives.
 - Locate and construct fireline in a manner that minimizes erosion and runoff from directly entering waterbodies by considering site slope and soil conditions, and using and maintaining suitable water and erosion control measures.
 - Consider alternatives to ground-disturbing fireline construction such as using wet lines, rock outcrops, or other suitable features for firelines.
 - Establish permanent fireline with suitable water and erosion control measures in areas where prescribed fire treatments are used on a recurring basis.
 - Maintain firebreaks in a manner that minimizes exposed soil to the extent practicable.
 - Rehabilitate or otherwise stabilize fireline in areas that pose a risk to water quality.
 - Alter prescribed fire prescriptions and control actions in the AMZs as needed to maintain ecosystem structure, function, and processes and onsite and downstream water quality.
 - Pretreat AMZs and drainage ways to reduce excessive fuel loadings.
 - Avoid building firelines in or around riparian areas, wetlands, marshes, bogs, fens, or other sensitive water-dependent sites unless needed to protect life, property, or wetlands.
 - Construct any essential fireline in the AMZ in a manner that minimizes the amount of area and soil disturbed.
 - Keep high-intensity fire out of the AMZ unless suitable measures are used to avoid or minimize adverse effects to water quality.

-
- ┆ Avoid or minimize complete removal of the organic layer when burning in riparian areas or wetlands to maintain soil productivity, infiltration capacity, and nutrient retention.
 - ┆ Rehabilitate fireline in the AMZ after prescribed fire treatment is completed.
 - ┆ Remove debris added to stream channels as a result of the prescribed burning unless debris is prescribed to improve fisheries habitat.
 - Conduct prescribed fire treatments, including pile burning, for slash disposal in a manner that encourages efficient burning to minimize soil impacts while achieving treatment objectives.
 - ┆ Pile and burn only the slash that is necessary to be disposed of to achieve treatment objectives.
 - ┆ Locate slash piles in areas where the potential for soil effects is lessened (meadows, rock outcrops, etc.) and that do not interfere with natural drainage patterns.
 - ┆ Remove wood products such as firewood or fence posts before piling and burning to reduce the amount of slash to be burned.
 - ┆ Minimize the amount of dirt or other noncombustible material in slash piles to promote efficient burning.
 - ┆ Construct piles in such a manner as to promote efficient burning.
 - ┆ Avoid burning large stumps and sections of logs in slash piles to reduce the amount of time that the pile burns.
 - ┆ Avoid burning when conditions will cause the fire to burn too hot and damage soil conditions.
 - ┆ Avoid piling and burning for slash removal in AMZs to the extent practicable.
 - ┆ Minimize effects on soil, water quality, and riparian resources by appropriately planning pile size, fuel piece size limits, spacing, and burn prescriptions in compliance with State or local laws and regulations if no practical alternatives for slash disposal in the AMZ are available.
 - Evaluate the completed burn to identify sites that may need stabilization treatments or monitoring to minimize soil and site productivity loss and deterioration of water quality both on and off the site.
 - ┆ Provide for rapid revegetation of all denuded areas through natural processes supplemented by artificial revegetation where necessary.
 - ┆ Use suitable measures to promote water retention and infiltration or to augment soil cover where necessary.
 - ┆ Use suitable species and establishment techniques to stabilize the site in compliance with local direction and requirements per FSM 2070 and FSM 2080 for vegetation ecology and prevention and control of invasive species.
 - ┆ Clear streams and ditches of debris introduced by fire control equipment during the prescribed fire operation.
 - ┆ Consider long-term management of the site and nearby areas to promote project success.
 - ┆ Use suitable measures to limit human, vehicle, and livestock access to site as needed to allow for recovery of vegetation.

Fire-3. Wildland Fire Control and Suppression

Manual or Handbook

Reference FSM 5130.

Objective Avoid or minimize adverse effects to soil, water quality, and riparian resources during fire control and suppression efforts.

Explanation Wildland fire control and suppression activities are aimed at stopping and extinguishing the fire and often occur without full knowledge of potential effects to soil, water quality, or riparian resources. Suppression activities include constructing fire line and temporary access roads, opening closed or access-limited system roads, clearing and grubbing safety zones, falling hazard trees, retrieving water and applying it to the fire, performing back-fire operations, and applying aerial or ground-based fire retardant. Soil disturbance and loss of ground cover from these activities can lead to accelerated erosion and sediment delivery to waterbodies. Certain fire retardant formulations are toxic to aquatic fauna, including fish. Water quality objectives are included in strategic and tactical fire management plans, but are secondary to firefighter and public safety during suppression activities.

Practices Develop site-specific BMP prescriptions for the following practices, as appropriate or when required, using State BMPs, Forest Service regional guidance, land management plan direction, BMP monitoring information, and professional judgment.

- Assign a watershed resource advisor, or team of watershed resource advisors, to work with incident management teams to minimize damage to soil, water quality, and riparian resources from fire and fire control and suppression activities.
- Locate Incident Command Post, air resource bases, staging areas, and other fire management support areas outside of the AMZ and at a suitable distance from waterbodies to minimize the potential for adverse effects to water quality.
 - ┆ Protect surface and subsurface water resources from nutrients, bacteria, and chemicals associated with solid waste and sewage disposal.
 - ┆ Collect and properly dispose of trash and other solid waste.
 - ┆ Use applicable practices of BMP Road-10 (Equipment Refueling and Servicing) when servicing, refueling, and cleaning vehicles and equipment.
 - ┆ Install suitable measures to minimize and control concentrated water flow and sediment from support areas.
- Use Minimum Impact Suppression Tactics during wildland fire control and suppression activities when and where practicable considering the appropriate management response and land management plan direction.
- Use preexisting features for safety zones as practicable to avoid unnecessary ground disturbance.
- Construct fireline to the minimum size and standard necessary to contain the fire and meet overall resource objectives.
 - ┆ Locate and construct fireline in a manner that minimizes erosion and runoff from directly entering waterbodies by considering site slope and soil conditions, and using and maintaining suitable water and erosion control measures.
 - ┆ Avoid building firelines in or around riparian areas, wetlands, marshes, bogs, fens, or other sensitive water-dependent sites unless needed to protect life or property.

-
- ↳ Use natural or in-place barriers that reduce or limit fire spread, such as roads, canals, utility rights-of-way, barren or low fuel hazard areas, streams, lakes, or wetland features as firelines where practicable, to minimize the need for fireline construction.
 - Use suitable measures to prevent or minimize runoff, erosion, and sediment delivery to waterbodies when using water for fire suppression activities.
 - Use suitable measures, consistent with current Forest Service policy, to minimize adverse effects to water quality when applying fire retardant or foam.
 - ↳ Use fire retardant formulations that are least toxic to aquatic flora and fauna and shift to less lethal formulations as they become available and affordable.
 - ↳ Avoid, to the extent practicable, aerial application of fire retardant or foam within a buffer area around waterbodies of sufficient size to minimize the potential for entry into the waterbody.
 - Conduct water drafting at suitable locations and in a manner that avoids or minimizes adverse effects to water quality (see BMP WatUses-3 [Administrative Water Developments]).
 - Evaluate the need to close or restrict use of surface and shallow groundwater resources following fire control activities that may have adversely affected water quality.

Fire-4. Wildland Fire Suppression Damage Rehabilitation

Manual or Handbook

Reference FSM 2523.4.

Objective Rehabilitate watershed features and functions damaged by wildland fire control and suppression-related activities to avoid, minimize, or mitigate long-term adverse effects to soil, water quality, and riparian resources.

Explanation Fire suppression and related activities can damage watershed features and functions by removing vegetation, exposing soil, and disrupting flow pathways. Corrective treatments are used to stabilize soil, control surface runoff and erosion, reduce flood potential, and stabilize the drainage network in areas directly affected by fire suppression and related activities. Fire incident management teams (IMTs) are responsible for rehabilitation of fireline, spike camps, roads, and other sites created and used to control and suppress the fire, where necessary, to protect resources. Resource advisors may assist the IMT in determining the sites in need of treatment as well as suitable corrective actions. Areas affected by the fire itself may require additional rehabilitation, including emergency treatments, (e.g., Burned Area Emergency Response [BAER] program) to protect watershed resources. These activities may be initiated by the affected management unit immediately following the fire or during a period of years after the fire to achieve desired objectives.

Practices Develop site-specific BMP prescriptions for the following practices, as appropriate or when required, using State BMPs, Forest Service regional guidance, land management plan direction, BMP monitoring information, and professional judgment.

- Conduct emergency stabilization assessments of fire damage that produces hazards to life or property as needed in accordance with BAER policy (FSM 2523 and FSH 2509.13).
- Reclaim and stabilize disturbed areas including safety zones, fireline, and base camps that have increased erosion potential or drainage patterns altered by fire suppression activities.
 - ↳ Reshape the ground surface and install suitable drainage features to promote dispersed runoff from the site.

-
- ↳ Mitigate soil compaction to improve infiltration and revegetation conditions.
 - ↳ Use suitable species and establishment techniques to stabilize the site in compliance with local direction and requirements per FSM 2070 and FSM 2080 for vegetation ecology and prevention and control of invasive species.
 - Repair roads, trails, and other facilities damaged by suppression activities that may adversely affect water quality and riparian resources.
 - ↳ Repair damaged road and trail drainage structures and conveyances to a condition where they can function as designed (See BMP Road-3 [Road Construction and Reconstruction] and BMP Road-4 [Road Operations and Maintenance]).
 - ↳ Reconstruct roads damaged by mechanized equipment to stabilize the road prism and running surface (See BMP Road-3 [Road Construction and Reconstruction]).
 - ↳ Close or decommission roads opened for access in a condition that reduces the risk of adverse effects to hydrologic function and water quality (see BMP Road-6 [Road Storage and Decommissioning]).
 - ↳ Repair and clear debris from water conveyance structures, such as ditches, to reduce the potential for failures and subsequent erosion.
 - Clear suppression-created debris from critical points in streams channels to reduce the potential for flooding or bank erosion.
 - ↳ Remove debris and sediment from existing drainage structures.
 - ↳ Remove debris introduced by fire control equipment during fire suppression activities.
 - ↳ Remove dams used to construct pools for water drafting into engines.
 - Evaluate the burned area to identify sites that may need rehabilitation treatments or monitoring to minimize soil and site productivity loss and deterioration of water quality both on and off the site.
 - ↳ Provide for rapid revegetation of critical denuded areas through natural processes supplemented by artificial soil surface cover or revegetation where necessary.
 - ↳ Prioritize needed treatments to rehabilitate AMZ structure, function, and processes before treating uplands.
 - ↳ Use suitable measures in compliance with local direction to prevent and control invasive species.

Resources for Wildland Fire Management Activities

Fire Retardant U.S. Department of Agriculture (USDA), Forest Service, Fire and Aviation Management. 2011. National aerial application of fire retardant 2011 final environmental impact statement and associated documents. Washington, DC. Available at http://www.fs.fed.us/fire/retardant/eis_info.html.

USDA Forest Service; U.S. Department of the Interior, Bureau of Land Management, National Park Service, and Fish and Wildlife Service. 2000. Guidelines for aerial delivery of retardant or foam near waterways. 2 p. Available at http://www.fs.fed.us/fire/retardant/references/US_Forest_Service_et_al_2000_Guidelines_for_Aerial_Delivery.pdf.

**Minimum Impact
Suppression Tactics**

National Wildfire Coordinating Group. 2010. Incident response pocket guide. PMS 461, NFES 1077. 130 p. Available at <http://www.nwccg.gov/pms/pubs/nfes1077/nfes1077.pdf>.

Wildland Fire Lessons Learned Center. Minimum impact suppression tactics guidelines. Tucson, AZ. 12 p. Available at http://wildfirelessons.net/documents/GB_MIST_Guidelines.pdf.

Prescribed Fire

Arkansas Forestry Commission. 2002. Arkansas forestry best management practices for water quality protection. Little Rock, AR. 60 p. Available at <http://forestry.arkansas.gov/Services/ManageYourForests/Pages/bestManagementPractices.aspx>.

USDA Natural Resources Conservation Service. National conservation practice standards—338 prescribed burning. Available at <http://www.nrcs.usda.gov/technical/standards/nhcp.html>.

U.S. Environmental Protection Agency, Office of Water. 2005. Chapter 3G: Fire management. In: National management measures to control nonpoint source pollution from forestry. EPA 841-B-05-001. Washington, DC. p. 3-89-3-92. Available at <http://www.epa.gov/owow/nps/forestrygmt/>.

Water Sources

Napper, C. 2006. Water-source toolkit. 0625 1806. San Dimas, CA: USDA Forest Service, Technology and Development Program. 74 p. Available at http://www.fs.fed.us/eng/pubs/pdf/WaterToolkit/lo_res.shtml.

Sicking, L.P. 2002. Water ejectors for use in wildland firefighting. 0251 1205P. San Dimas, CA: USDA Forest Service, Technology and Development Program. 52 p. Available at <http://www.fs.fed.us/eng/pubs/pdf/02511205.pdf>.

Minerals Management Activities

The purpose of this set of Best Management Practices (BMPs) is to avoid, minimize, or mitigate adverse effects to soil, water quality, and riparian resources that may result from various mineral exploration, development, operation, and reclamation activities. Minerals on National Forest System (NFS) lands fall into four categories described in table 3.

Table 3.—*Categories of minerals on NFS lands.*

Locatable minerals (Forest Service Manual [FSM] 2810)	Metals and rare earth elements such as uranium. Uncommon varieties of sand, stone, gravel, pumice, pumicite, cinders, and clay.
Leasable minerals (FSM 2820)	Oil and gas, coal, phosphate, potassium, sodium, sulphur, gilsonite, oil shale, and geothermal resources. Hardrock minerals located on acquired lands.
Mineral materials (FSM 2850)	Common varieties of sand, stone, gravel, pumice, pumicite, cinders, and clay.
Mineral reservations and outstanding rights (FSM 2830)	Reserved rights—private mineral rights retained in private owner conveyance. Outstanding rights—private mineral rights in deed restrictions for some tracts of acquired forest land.

In general, the Forest Service’s objective for managing mineral and energy resources on NFS lands is to encourage and facilitate the orderly exploration, development, and production of these resources in an environmentally sound manner integrated with the management of other national forest resources. In addition, NFS lands disturbed by mineral activities are to be reclaimed for other productive uses (FSM 2802). The extent to which the Forest Service has the authority to regulate mineral operations and require measures to avoid, minimize, mitigate, and reclaim surface disturbance varies with the mineral commodity in question and status of the land on which it is located. In all cases where there appears to be a conflict between applicable law, regulation, and suggested BMPs, the law or regulation takes precedence.

Eight National Core BMPs are in the Minerals Management Activities category. These BMPs are to be used during all minerals management activities on NFS lands, to the extent allowed by Federal and State minerals development laws and regulations. BMP Min-1 (Minerals Planning) is a planning BMP for minerals management at the land management plan scale and project scale. Mineral exploration and production activities are similar for many of the minerals managed by the Forest Service. Practices for exploration activities are in BMP Min-2 (Minerals Exploration) and practices for production activities are in BMP Min-3 (Minerals Production). BMP Min-4 (Placer Mining) provides direction for extracting metals from alluvial deposits in or near stream channels. BMP Min-5 (Minerals Materials Resource Sites) provides direction for extracting aggregate materials from waterbodies and upland sites. BMP Min-6 (Ore Stockpiles, Mine Waste Storage and Disposal, Reserve Pits, and Settling Ponds) covers onsite storage and disposal of solid and liquid mine wastes. BMP Min-7 (Produced Water) provides direction for treatment and disposal of water produced at drilling sites. BMP Min-8 (Minerals Site Reclamation) provides direction for reclamation of mines and drilling sites.

States will be used in the rest of this resource category to signify both States and those tribes that have received approval from the U.S. Environmental Protection Agency (EPA) for treatment as a State under the Clean Water Act (CWA).

Minerals Activities BMPs	
Min-1	Minerals Planning
Min-2	Minerals Exploration
Min-3	Minerals Production
Min-4	Placer Mining
Min-5	Mineral Materials Resource Sites
Min-6	Ore Stockpiles, Mine Waste Storage and Disposal, Reserve Pits, and Settling Ponds
Min-7	Produced Water
Min-8	Minerals Site Reclamation

Min-1. Minerals Planning

Manual or Handbook

Reference FSM 2810, FSM 2820, FSM 2830, and FSM 2850.

Objective Use the minerals planning process to develop measures to avoid, minimize, or mitigate adverse effects to soil, water quality, and riparian resources during minerals exploration, production, operations, and reclamation activities.

Explanation When minerals activities are proposed for NFS lands, the Forest Service conducts or participates in an analysis as required by the National Environmental Policy Act (NEPA) and the applicable approval or authorization procedures to comply with laws governing mineral disposal and environmental protection and to ensure consistency with the land management plan. During this analysis and approval process, the Forest Service consults and cooperates with other State and Federal agencies to identify the environmental impacts that will occur; to develop measures to avoid, minimize, or mitigate adverse effects to soil, water quality, and riparian resources; and to determine reclamation needs and formulate appropriate bonding. These measures are implemented through the approved plan, contract, or other authorization.

Through the Bureau of Land Management (BLM), the U.S. Department of the Interior has the primary role in issuing mineral leases and permits and supervising operations for many mineral activities. The Forest Service coordinates with the BLM to ensure that land management plan resource management desired conditions, goals, and objectives are achieved; impacts to land surface resources are minimized or mitigated; and the affected land is promptly rehabilitated. Through the NEPA process the Forest Service and BLM make a determination as to whether an authorization or lease will be issued and identify stipulations needed to avoid, minimize, or mitigate adverse effects to soil, water quality, and riparian resources.

Practices Develop site-specific BMP prescriptions for the following practices, as appropriate or when required, using State BMPs, Forest Service regional guidance, land management plan direction, BMP monitoring information, and professional judgment.

All Activities

- Use applicable practices of BMP Plan-2 (Project Planning and Analysis) and BMP Plan-3 (Aquatic Management Zone [AMZ] Planning) when planning minerals activities.
- Identify potential environmental risks of the proposed minerals activities and include measures in project plans to manage risk by removing or eliminating the source of risk, changing the mining plan, or removing the resource at risk from harm's way.

-
- Inform proponent that a Clean Water Act (CWA) 402 permit may be required if the minerals operation causes a point source or stormwater discharge of any pollutant to waters of the United States.
 - Inform proponent that a CWA 404 permit may be required if the mining operations will result in a discharge of dredge or fill material to waters of the United States.
 - Evaluate plan of operations to ensure that reasonable measures, including appropriate BMPs, are included to avoid and minimize adverse effects to soil, water quality, and riparian resources from the mining activities.
 - ┆ Require suitable geotechnical or stability analyses to ensure that facilities are constructed to acceptable factors of safety using standard engineering practices and considering foundation conditions and material; construction materials and techniques; the seismicity of the area; and the water-related resources at risk.
 - ┆ Require suitable characterization of ore, waste rock, and tailings using accepted protocols to identify materials that have the potential to release acidity or other contaminants when exposed during mining.
 - ┆ Require suitable characterization of mine site hydrology commensurate with the potential for impacts to surface water and groundwater resources, to include physical and chemical characteristics of surface and groundwater systems, as needed, for the range of expected seasonal variation in precipitation and potential stormflow events likely to occur at the site for the duration of the minerals activities.
 - ┆ Stipulate suitable requirements, including water treatment as needed, to avoid or minimize the development and release of acidic or other contaminants.
 - ┆ Use applicable practices from the Minerals Management Activities BMPs.
 - ┆ Evaluate the consumptive use of water in the mining operation and its effect on water-dependent ecosystems.
 - ┆ Evaluate the potential for direct and indirect impacts to morphology, stability, and function of waterbodies, riparian areas, and wetland habitats.
 - ┆ Identify suitable measures to avoid impacts to waterbodies, riparian areas, and wetland habitats through appropriate location, design, operation, and reclamation requirements.
 - ┆ Identify suitable interim and post-project surface water and groundwater monitoring where needed to confirm predictions of impacts, detect adverse changes at the earliest practicable time, and develop appropriate changes in operations or recommend closure where needed.
 - ┆ Request a copy of operator's CWA 401 Certification from designated Federal, State, or local entity before approving a plan of operations that may result in any discharge into waters of the United States.
 - As outlined in the Forest Service Training Guide for Reclamation Bond Estimation and Administration for Minerals Plans of Operation, consider the direct and indirect costs of stabilizing, rehabilitating, and reclaiming the area of mineral operations to the appropriate standards for water quality and watershed condition as determined from the land management plan, State and Federal laws, regulations, plans, or permits when determining the reclamation bond amount. Include costs for:
 - ┆ Operation and maintenance of facilities designed to divert, convey, store, or treat water.
 - ┆ Decontaminating, neutralizing, disposing, treating, or isolating hazardous materials at the site to minimize potential for contamination of soil, surface water, and ground water.
 - ┆ Water treatment needs predicted during planning and discovered during operations to achieve applicable water quality standards.

-
- ↳ Earthwork to reclaim roads; waste rock dumps; tailings; backfilling water features (diversions, ditches, and sediment ponds); and construction of diversion channels and drains, stream channels, and wetlands.
 - ↳ Revegetation to stabilize the site and minimize soil erosion.
 - ↳ Mitigation to restore natural function and value of streams, wetlands, and floodplains.
 - ↳ Long-term operations, monitoring, and maintenance of mineral production-related facilities that must perform as designed to avoid or minimize contamination of surface or groundwater resources, including roads, diversion ditches, dams, and water treatment systems.
 - ↳ Protection of the reclaimed area until long-term stability, erosion control, and revegetation has been established.

Locatable Minerals

- Evaluate Notice of Intent to Operate proposal to determine if it will likely cause significant disturbance to soil, water quality, and riparian resources.
 - ↳ Require a plan of operation from the mineral operator, lessee, or purchaser as required by law and regulation if proposed activities might cause significant disturbance of surface resources including soil, water quality, or riparian resources.

Minerals Leasing

- Include in the land management plan, or other areawide decision document, direction for surface occupancy. Use lease stipulations to avoid riparian areas, wetlands, and areas subject to mass soil movement; to avoid or minimize erosion and sediment production; and to avoid or minimize adverse effects to water quality and municipal supply watersheds, if these issues are not adequately addressed by provisions in regulations at 36 CFR 228.108.
- Use the applicable practices from the Minerals Activities BMPs for recommendations on post-lease approval of operations.
- Require or work with BLM to require appropriate contingency plans to avoid or minimize adverse impacts to surface waters.
- Coordinate with BLM to ensure the reclamation bond required for operations will be sufficient to guarantee reclamation work on NFS lands to the appropriate standards for water quality and watershed condition as determined from the land management plan, State and Federal laws, regulations, plans, or permits.

Mineral Materials

- Include reasonable conditions and applicable practices of BMP Min-3 (Minerals Production) and BMP Min-5 (Mineral Materials Resource Sites) in the operating plan to ensure proper protection of soil, water quality, and riparian resources and timely reclamation of disturbed areas.
- Consider the direct and indirect costs of stabilizing, rehabilitating, and reclaiming the area of mineral materials operations to the appropriate standards for water quality and watershed condition as determined from the land management plan, State and Federal laws, regulations, plans, or permits when determining the reclamation bond amount.

Mineral Reservations and Outstanding Mineral Rights

- Evaluate the Operating Plan for Mineral Reservation Operations to ensure that reasonable measures, including appropriate BMPs, consistent with the terms of the deed, are included to

minimize damage to NFS surface resources that could affect soil, water quality, and riparian resources and that provide for restoration and reclamation of disturbed lands.

- Evaluate the Operating Plan for Outstanding Mineral Rights to ensure that reasonable measures, including appropriate BMPs, are included to control erosion, avoid or minimize water pollution, and reclaim the site consistent with land management plan direction for water quality management.

Min-2. Minerals Exploration

Manual or Handbook

Reference FSM 2810, FSM 2820, and FSM 2850.

Objective Avoid, minimize, or mitigate adverse effects to soil, water quality, and riparian resources caused by physical and chemical pollutants during minerals exploration activities.

Explanation Minerals exploration is the process of determining the location, extent, composition, and quality of deposits of minerals and energy resources that can be commercially developed. Exploration methods may include remote sensing, geochemical analysis of water, rock and soil samples, geophysical analysis, and ground-disturbing activities including drilling, bulldozing, trenching, and excavating shallow pits, exploration shafts, or adits. During construction of drill pads, trenches, pits, or shafts, land may be cleared of existing vegetation and ground cover, exposing mineral soil that may be more easily eroded by water, wind, and gravity. Underground activities may intercept groundwater, exposing these aquifers to potential contaminants.

Practices Develop site-specific BMP prescriptions for the following practices, as appropriate or when required, using State BMPs, Forest Service regional guidance, land management plan direction, BMP monitoring information, and professional judgment.

- Avoid or minimize long-term impacts to soil, water quality, and riparian resources to the extent permitted by the geologic target when selecting locations for exploration activities.
 - Avoid waterbodies, sensitive areas, unstable slopes, and highly erosive soils to the extent practicable.
- Limit clearing, excavation, and other surface-disturbing activities to the minimum necessary for exploration needs.
 - Consider using exploration drilling and support vehicles that do not require road construction.
- Design and construct all new roads and drilling pads to a safe and appropriate standard, no higher than necessary to accommodate their intended use (see BMP Road-2 [Road Location and Design], BMP Road-3 [Road Construction and Maintenance], and BMP Road-4 [Road Operations and Maintenance]).
- Employ suitable design and construction practices to avoid, minimize, or mitigate surface disturbances as well as maintain the reclamation potential of the site.
 - Use directional drilling techniques when practicable to avoid or reduce surface disturbance.
 - Plan and construct, to the extent practicable, exploration roads to be recontoured when operations are complete.
- Limit the extent of open exploratory areas at one time and restore one site before moving on to the next one, to the extent practicable.
- Use applicable practices from BMP Fac-2 (Facility Construction and Stormwater Control) to minimize erosion and stormwater discharge from ground disturbance at exploration sites.

- Use applicable practices from BMP Fac-4 (Sanitation Systems) and BMP Fac-5 (Solid Waste Management) to avoid contaminating surface water or groundwater from sanitation or solid waste facilities.
- Use applicable practices of Chemical Use Management Activities BMPs when chemicals are used in exploration activities.
- Use applicable practices of BMP Fac-6 (Hazardous Materials) and BMP Road-10 (Equipment Refueling and Servicing) to manage petroleum products and other hazardous materials used in exploration activities.
 - Require a transportation spill response plan, where applicable, that describes the petroleum products or other hazardous materials or chemicals that will be used in the operations, including the routes, amount and frequency of shipments, and containers and vehicles used. Describe in this plan the procedures, equipment, and personnel that would be used to respond to a spill.
- Properly manage all exploration-related wastes, including drilling fluids, produced water, and potentially acid-generating rock materials, to minimize the risk of groundwater and surface water contamination and to meet State and Federal requirements.
 - Use applicable practices of BMP Min-6 (Ore Stockpiles, Mine Waste Storage and Disposal, Reserve Pits, and Settling Ponds) and BMP Min-7 (Produced Water).
- Protect groundwater developments and groundwater-dependent ecosystems from the impacts of shock waves when using shot explosions to determine gas reserves or other energy development potential.
- Use applicable practices of BMP Min-8 (Minerals Site Reclamation) to reclaim the project site after exploration activities are completed.

Min-3. Minerals Production

Manual or Handbook

Reference FSM 2810, FSM 2820, and FSM 2850.

Objective Avoid, minimize, or mitigate adverse effects to soil, water quality, and riparian resources caused by physical and chemical pollutants resulting from mineral development, production, and associated activities.

Explanation Minerals production is the process of opening the mineral or oil and gas deposit; extracting the mineral resource (beneficiation); and processing the mineral resource to put it in a marketable condition. Minerals are extracted through surface mining (open pit or strip mining), underground mining (shafts or adits), or wells for fluid materials or solvent extraction. In addition to land clearing for mineral extraction, a minerals production site will also require clearing and ground disturbance for accessory buildings and facilities for minerals processing, storage, and transportation. Exposed soils may be subject to accelerated erosion if proper erosion controls are not used. Hazardous chemicals may be used in the process of extracting and processing minerals. Extraction and beneficiation operations associated with mining activities can generate acid mine drainage when sulfide rock materials are exposed to air and water. These materials may contaminate surface water or groundwater if not handled appropriately.

Practices Develop site-specific BMP prescriptions for the following practices, as appropriate or when required, using State BMPs, Forest Service regional guidance, land management plan direction, BMP monitoring information, and professional judgment.

All Activities

- Avoid or minimize long-term impacts to soil, water quality, and riparian resources to the extent permitted by the geologic target when selecting locations for the mining operation, structures, roads, and ore and waste facilities.
 - Provide adequate buffers and setbacks from waterbodies to avoid or minimize impacts to water quality and aquatic ecosystems.
- Employ suitable design and construction measures to avoid, limit, or mitigate surface disturbances as well as maintain the reclamation potential of the site.
- Use applicable practices from BMP Fac-2 (Facility Construction and Stormwater Control) to minimize erosion and stormwater discharge from ground disturbance at minerals production sites and to keep production sites dry.
- Properly manage mining byproducts and wastes.
 - Minimize production of byproducts and wastes to the extent practicable.
 - Plan space to properly handle, store, and contain byproducts and wastes.
 - Find suitable onsite or offsite uses for mining byproducts.
 - Recycle or properly dispose of wastes (e.g., used petroleum products, site garbage, septic effluent, decommissioned equipment, and used barrels or containers).
 - Minimize handling of byproducts and wastes to the extent practicable.
- Use applicable Road Management Activity BMPs to manage roads and transportation at the project site.
- Use applicable practices from BMP Fac-4 (Sanitation Systems) and BMP Fac-5 (Solid Waste Management) to avoid contaminating surface water or groundwater from sanitation or solid waste facilities.
- Use applicable Chemical Use Management Activities BMPs, BMP Fac-6 (Hazardous Materials), and BMP Road-10 (Equipment Refueling and Servicing) to manage all chemicals, reagents, fuels, and other hazardous or toxic materials used for construction, operations, and beneficiation to avoid or minimize contaminating surface water or groundwater.
- Use applicable practices from BMP Min-8 (Minerals Site Reclamation) to reclaim the project site after minerals production operations are completed.
- Use applicable practices of BMP Min-6 (Ore Stockpiles, Mine Waste Storage and Disposal, Reserve Pits, and Settling Ponds) and BMP Min-7 (Produced Water) to protect soil, water quality, and riparian resources in minerals extraction and processing, geothermal energy, and oil and gas production activities.
- Require a transportation spill response plan, where applicable, that describes the petroleum products or other hazardous materials or chemicals that will be used in the operations, including the routes, amount, and frequency of shipments, and the containers and vehicles that are to be used. Describe in this plan the procedures, equipment, and personnel that would be used to respond to a spill.
- Make adjustments in the plans, authorizations, and bonds if conditions develop that are outside the design criteria and conduct adequate notification, emergency stabilization, or other activities to avoid effects before proceeding with additional mining.

Mining-Related Surface Activities

- Limit clearing, excavation, and other surface-disturbing activities to the minimum necessary for mining needs.
 - Limit amount of exposed or disturbed soil at any one time to the minimum necessary for efficient operations during minerals production activities.
 - Clearly delineate the geographic limits of the area to be cleared.
 - Install suitable drainage measures to improve the workability of wet sites.
 - Avoid or minimize damage to existing vegetation, particularly the vegetation that is stabilizing the bank of a waterbody.
 - Stabilize mined areas and surface disturbance activities as soon as practicable before moving and opening up new areas.
- Reduce surface-disturbing activities to the minimum necessary for efficient minerals production activities during periods of heavy runoff or saturated soil conditions, to the extent practicable, to decrease the potential for soil compaction and erosion.
- Stockpile biologically active topsoil removed during excavation for use in reclamation.
 - Store stockpiled topsoil separately from other vegetative slash or soil and rock materials and protect from wind and water erosion, unnecessary compaction, and contaminants.
- Conduct operations in such a manner as to avoid or minimize the production and transport of fugitive dust from the site.
- Use suitable measures in compliance with local direction to prevent and control invasive species.

Mining-Related Subsurface Activities

- Develop the mine plan to suitably address surface stability and avoid or minimize the unnecessary diversion of runoff or surface waters into the subsurface.
- Use suitable water management and control measures to minimize water inflow, use inflow for mineral operations to the extent practicable, and manage inflow to minimize the accumulation of contaminants including blasting residuals.
- Manage ventilation systems to minimize deposition of airborne contaminants on the ground surface.

Geothermal, Oil, and Gas Activities

- Locate well sites on level locations that will accommodate the intended use to reduce the need for vertical cuts and steep fill slopes.
 - Use directional drilling techniques when practicable to avoid or reduce surface disturbance.
- Use suitable measures to stabilize fill slopes and minimize potential of slope failures.
- Use suitable measures to provide surface drainage and manage runoff from the work areas used for mud tanks, generators, mud storage, and fuel tanks in a manner that avoids or minimizes pollutant contamination of surface waters or groundwater.
- Use nontoxic, nonhazardous drilling fluids whenever practicable.
- Construct suitable impervious containment structures with sufficient volume and freeboard to avoid or minimize spills or leakages of oil, gas, salt water, toxic liquids, or waste materials from reaching surface waters or groundwater.

-
- Avoid mixing of geothermal fluids with surface water or groundwater where the chemical and thermal properties of the geothermal fluids would damage aquatic ecosystems and contaminate drinking water supplies.

Mining-Related Instream Activities

- Use applicable practices of BMP AqEco-2 (Operations in Aquatic Ecosystems) when conducting mining in waterbodies.

Min-4. Placer Mining

Manual or Handbook

Reference FSM 2810.

Objective Avoid, minimize, or mitigate adverse effects to soil, water quality, and riparian resources when conducting placer mining operations in or near stream channels.

Explanation Placer mining involves mining and extracting gold or other heavy metals and minerals primarily from alluvial deposits. These deposits may be in existing streambeds or in ancient, often buried, stream deposits. Suction dredge placer mining is the most common in-channel operation and removes gold and other minerals from streambed substrates. All floating suction dredges are designed to work as a unit to dig, classify, and beneficiate ores and to dispose of waste within the stream channel. Placer mining operations can also occur adjacent to stream channels and other waterbodies. The essential components of placer mining include removing the overburden, mining the placer deposits, and processing the ore to recover the desired mineral. Overburden and placer deposits can be excavated by a variety of means ranging from hand tools to heavy equipment. Excavated placer pay gravels are typically processed using a variety of gravity separation techniques that yield gold or other heavy metal concentrates. Concentration of gold and other precious metals sometimes takes place onsite using mercury amalgamation or other techniques. Waste products from placer mining include tailings and process water. Effects to soil, water quality, and riparian resources from these operations include direct modification of the waterbody, release of contaminated waters, groundwater disruption, and increased levels of turbidity and sediment.

Practices Develop site-specific BMP prescriptions for the following practices, as appropriate or when required, using State BMPs, Forest Service regional guidance, land management plan direction, BMP monitoring information, and professional judgment.

All Activities

- Use applicable practices of BMP AqEco-2 (Operations in Aquatic Ecosystems), BMP AqEco-3 (Ponds and Wetlands), and BMP AqEco-4 (Stream Channels and Shorelines) when working in or near aquatic ecosystems to prevent or minimize adverse impacts to water quality.
- Use applicable practices of BMP Min-3 (Mineral Production) for sanitation, solid waste, and transport and storage of petroleum products or other hazardous materials.

Suction Dredge Mining

- Conduct dredging and excavation operations in such a manner as to avoid creating dams or diversions, including inadvertent damming caused by tailing placement.
- Conduct dredging and excavation operations only within the existing wetted perimeter (waterline) in the active stream channel and avoid mining or otherwise disturbing streambanks.

- Schedule dredging or excavation to avoid periods and locations where fish are spawning or where fish eggs or fry are known to exist at the time dredging occurs.
- Provide adequate passage for fish around and through the mining area.
- Provide space between current and recent dredging and excavation operations to avoid overlapping of water quality and habitat effects from concurrent or successive operations to provide areas of unimpacted substrate for fish and other aquatic organisms.
- Conduct dredging and excavation operations in such a manner as to retain large boulders, logs, or other natural obstructions in place to preserve large habitat-forming elements.
- Conduct dredging and excavation operations in such a manner as to avoid significant increases in downstream turbidity.

Mechanical Placer Mining in Riparian and Floodplain Areas

- Use applicable practices of BMP Min-3 (Minerals Production) in removing overburden to access placer deposits.
- Use applicable practices of BMP Min-6 (Ore Stockpiles, Mine Waste Storage and Disposal, Reserve Pits, and Settling Ponds) and BMP Min-7 (Produced Water) to avoid, minimize, or mitigate adverse effects to soil, water quality, and riparian resources when processing materials.
- Use suitable measures to avoid or minimize the entrainment of fish when obtaining water from a fish-bearing stream for placer mining operations.

Min-5. Mineral Materials Resource Sites

Manual or Handbook

Reference FSM 2850.

Objective Avoid, minimize, or mitigate adverse effects to soil, water quality, and riparian resources when developing and using upland mineral materials resource sites or instream sand and gravel deposits.

Explanation Mineral materials resource sites include upland and instream sites that are mined to obtain mineral materials such as sand, gravels, cobbles, and boulders. Upland aggregate deposits also include finer materials such as sand, silt, clay, and organic debris that can be mobilized during or following desired material extraction operations. The principal pollutant generated at quarries is total suspended solids and, therefore, erosion and sediment control should be the major focus during all phases of the quarry operation. The size and location of the deposit, as well as the amount and duration of need for materials, are commonly the key factors to consider when evaluating and designing an appropriate strategy to remove the materials and stabilize the site following mining operations.

Deposits of sand and gravel, the unconsolidated granular materials resulting from the natural disintegration of rock or stone, are generally found in near-surface alluvial deposits and in subterranean and subaqueous beds. Instream sand and gravel mining operations consist of extracting sand and gravel deposits from the stream channel and processing and stockpiling aggregate materials at a nearby site on land. Instream extraction is accomplished by dredging underwater deposits; mining point bars, lateral bars, and islands that are above the low-water level; mining of temporarily or permanently dewatered channels; or by creating instream harvest pits by placement of rock vortex weirs. Effects to water quality and aquatic ecosystems from these operations can include direct physical modification of the waterbody and hydraulics, reduction in bedload and change in bedload transport, release of contaminated waters, groundwater disruption, and increased levels of turbidity.

Practices Develop site-specific BMP prescriptions for the following practices, as appropriate or when required, using State BMPs, Forest Service regional guidance, land management plan direction, BMP monitoring information, and professional judgment.

All Activities

- Allow upland and instream sand and gravel mining where consistent with land management plan desired conditions, goals, and objectives for soils, aquatic and riparian habitats, and water quality.
- Use applicable practices of BMP Min-3 (Minerals Production) and BMP Fac-2 (Facility Construction and Stormwater Control) for sanitation, solid waste, and transport and storage of petroleum products or other hazardous materials and to control erosion, manage stormwater, keep the site dry, and protect the waterbody when clearing the extraction and processing areas.
- Use applicable practices of BMP Min-6 (Ore Stockpiles, Mine Waste Storage and Disposal, Reserve Pits, and Settling Ponds) and BMP Min-7 (Produced Water) to avoid, minimize, or mitigate adverse effects to soil, water quality, and riparian resources when processing materials.

Upland Gravel Pits

- Plan operations at the site in advance to minimize disturbance area and more effectively and efficiently open and operate the site.
 - ┆ Limit the area of the facility to the minimum necessary for efficient operations while providing sufficient area for materials processing and stockpiling.
 - ┆ Phase development where practicable.
 - ┆ Use suitable measures to avoid, mitigate, or treat metal leaching and formation of acid rock drainage.
- Conduct extraction activities in such a manner as to minimize the potential for slope failures, limit slope steepness and length, limit disturbed areas to those actively used for extraction, retain existing vegetation as long as possible, and allow for progressive reclamation of the site where practicable.

Instream Sand and Gravel Mining

- Use applicable practices of BMP AqEco-2 (Operations in Aquatic Ecosystems), BMP AqEco-3 (Ponds and Wetlands), and BMP AqEco-4 (Stream Channels and Shorelines) when working in or near waterbodies to prevent or minimize adverse impacts to water quality.
- Consider channel type and effects of the proposed operation on channel morphology and function when approving instream sand and gravel mining operations.
- Limit access disturbance to designated areas on one streambank to reduce the effort required for site reclamation.
 - ┆ Use suitable measures to protect the streambank at access points to minimize bank erosion.
- Locate the material processing and stockpile site at a suitable distance from the active channel to leave a buffer zone along the waterbody to reduce risk of flooding.
 - ┆ Consider historic channel migration patterns and site elevation when locating mineral processing and stockpile sites.
 - ┆ Avoid or minimize disturbance to valuable riparian areas; wetlands; and aquatic-dependent threatened, endangered, and sensitive species habitat.
- Include suitable measures to protect channel morphology and function when extracting sand and gravel deposits.

- ┆ Specify the maximum depth of mining.
- ┆ Limit extraction depth to minimize slope changes along the stream, avoid or minimize channel and bank erosion, and retain existing natural channel armoring.
- ┆ Limit extraction amount to minimize upstream and downstream effects due to changes in bedload transport.
- ┆ Avoid modifying point bars to the extent where the resultant channel changes cause unacceptable reduced sinuosity or increased stream gradient, velocity, stream power, and bank instability.
- ┆ Schedule in-channel mining to occur during low-flow periods.
- ┆ Avoid or minimize changes to channel shape and reduce effects of mining on aquatic habitats by establishing a low-flow buffer.
- ┆ Avoid or minimize streambank erosion and instability during and after mining.
- ┆ Avoid or minimize headward erosion of the channel at the upstream end of the instream pit.
- Design and construct diversion channels to handle anticipated flow volumes and to minimize upstream and downstream effects of changes in stream grade, width, depth, bed characteristics, bank instability, and groundwater inflows when temporarily or permanently dewatering stream channels to extract sand and gravel.
 - ┆ Ensure barrier is able to adequately protect the dewatered mining area from flood flows.
- Conduct excavation operations in such a manner as to avoid significant increases in downstream turbidity.

Min-6. Ore Stockpiles, Mine Waste Storage and Disposal, Reserve Pits, and Settling Ponds

Manual or Handbook

Reference FSM 2810, FSM 2820, and FSM 2850.

Objective Avoid, minimize, or mitigate adverse effects to soil, surface water, groundwater, and riparian resources from physical and chemical contaminants originating from ore stockpiles, storage and disposal of mine waste, and construction and use of reserve pits and settling ponds.

Explanation Minerals production and processing generates large amounts of materials including ore stockpiles, waste rock, tailings, drilling muds and cuttings, and process water. These materials may contain minerals, hazardous chemicals, and other potential pollutants that can have severe impacts on water resources.

This practice addresses the management of ore and mine wastes as well as construction and operation of reserve pits, settling ponds, slime ponds, process water ponds, and tailings impoundments. Most operations divert surface water and groundwater around a site, collect waters after passing through or under a site, or employ a combination of both. When water and waste are diverted, implementation focuses on isolating the wastes to contain, settle, control, stabilize, or otherwise minimize contamination, whereas practices for flow-through systems focus on methods to collect, store, and treat contaminated waters.

Practices Develop site-specific BMP prescriptions for the following practices, as appropriate or when required, using State BMPs, Forest Service regional guidance, land management plan direction, BMP monitoring information, and professional judgment.

Ore Stockpiles and Mine Waste Facilities

- Locate ore stockpiles and waste facilities on stable, level sites with adequate drainage, away from surface water, shallow groundwaters, and poorly drained soils where practicable.
 - ↳ Establish adequate buffers and setbacks between the facility footprint and waterbodies to avoid or minimize adverse effects to water quality and aquatic ecosystems.
- Divert, control, collect, detain, and disperse surface runoff before contact with ore stockpiles and mine wastes.
 - ↳ Use suitable measures to ensure that pollutants are removed from runoff that was in contact with ore stockpiles or waste facilities and are not discharged or released into surface waters or groundwater.
- Properly characterize ore and waste rock to identify materials that have the potential to release acidity or other contaminants when exposed by mining.
- Use suitable measures to minimize development and prevent release of acidity or other contaminants.
 - ↳ Segregate and isolate potentially problematic materials from air and water.
 - ↳ Install impermeable caps, liners, and surface water diversions.
 - ↳ Blend acid-consuming materials, such as limestone, with the waste.
 - ↳ Require water treatment as needed.
- Limit slope steepness and length to interrupt surface runoff and reduce soil erosion.
- Install suitable support structures, such as retaining walls, in conjunction with a drainage system to support facility berms while draining excess water.
- Construct waste facilities in successive lifts where practicable to promote long-term stability and post-reclamation land productivity.
- Use suitable measures to stabilize stockpiles not scheduled for immediate processing to avoid or minimize wind and water erosion, oxidation of reactive materials, and runoff of toxic waters.
- Monitor containment dams and water and sediment control features to ensure contaminants are not reaching streams or other sensitive resources.

Reserve Pits

- Locate reserve pits in stable areas on the drill pad to the extent practicable.
- Locate pits away from natural watercourses, riparian areas, wetlands, floodplains, and areas of shallow groundwater wherever practicable.
 - ↳ Use suitable measures to ensure full containment of drilling fluids where the reserve pit must be placed in a sensitive location or in porous material.
- Design the reserve pit to contain all anticipated drilling muds, cuttings, fracture fluids, and precipitation while maintaining a suitable amount of freeboard to avoid or minimize overtopping.
- Use suitable measures to avoid or minimize seepage from the reserve pit contaminating groundwater.
- Remove any visible or measurable layer of oil from the surface of the reserve pit after cessation of drilling and completion of operations, and continue to keep the pit free of oil.
- Use suitable measures to avoid or minimize surface waters and groundwater from entering open pits.

Tailings, Settling, Process Water, and Slime Ponds

- Use the minimum amount of water necessary for efficient materials processing to reduce the volume of water requiring treatment, maximize the capacity of settling ponds, and avoid contaminating nonprocess water.
 - ┆ Recycle treatment water or used closed loop systems where practicable.
- Use suitable measures to treat, store, and dispose of wastewater from mine inflows and leaching and milling operations in a manner that avoids or minimizes adverse effects to soil, water quality, and riparian resources.
- Use suitable measures to ensure that pollutant materials removed from the process water and wastewater streams are retained in storage areas and are not discharged or released into surface waters or groundwater.
 - ┆ Design, construct, operate, and maintain water control devices, such as diversion structures and berms, and all solids retention structures, such as berms, dikes, pond structures, and dams, to function effectively through the life of the project with reduced risk of failure.
 - ┆ Locate storage ponds and storage areas in places where they will not be washed out by reasonably predictable flooding or return of a relocated stream to its original streambed.
 - ┆ Place materials removed from settling ponds in locations where liquids from the materials cannot flow overland into surface waters.
 - ┆ Provide for contingencies to avoid or minimize failure and release of untreated wastes and wastewater into waters of the United States or waters of the State.
- Design tailings facilities, dams, and berms to acceptable factors of safety using standard geotechnical engineering practices and considering foundation conditions and materials; construction materials and practices; the seismicity of the area; and the human and environmental resources at risk.
- Design ponds to contain all sediment-laden process water as well as surface runoff, seepage, and expected precipitation.
 - ┆ Use suitable measures to ensure that water is kept below the crest of the dam or berm.
 - ┆ Size the spillway to release overflows in a volume and velocity that does not erode the spillway, the area beyond the outlet or the downstream channel.
 - ┆ Use suitable measures to ensure water meets applicable Federal, State, and local water quality standards before discharge to waters of the United States or waters of the State.
- Divert surface water around the impoundment area before construction and, where appropriate, construct a drain field below dams and berms to reduce the water levels to maintain structural integrity.
- Install monitoring devices to measure water levels and mass movement within tailings or water retaining structures where human and environmental resources are at risk.
- Use suitable measures to minimize groundwater seepage into impoundments and avoid or minimize leaching of contaminated waters into the groundwater.
- Construct watertight impoundments for containment of mill process water, cyanide solutions, sulfide tailings, or phosphate slimes.
- Use closed-system ponds when water contains potentially hazardous materials such as cyanide or other beneficiation chemicals.
 - ┆ Ensure that solutions containing chemicals used in beneficiation, such as floatation reagents or cyanide, are properly treated or removed from process ponds and disposed of in accordance with applicable State and Federal requirements.

-
- Install and seasonally monitor groundwater quality monitoring wells if a risk of groundwater pollution exists (see BMP WatUses-2 [Water Wells for Production and Monitoring]).
 - Establish a suitable inspection schedule to ensure that water diversion structures, conveyances, and storage facilities are performing as designed and appropriately maintained.

Min-7. Produced Water

Manual or Handbook

Reference FSM 2820.

Objective Avoid, minimize, or mitigate adverse effects to soil, water quality, and riparian resources by appropriately managing water produced during the extraction of minerals, geothermal energy, oil, and gas.

Explanation Produced water is often a byproduct of oil and gas, geothermal energy, and mineral exploration and production due to the dewatering of underground aquifers. Disposal of produced water is a critical environmental impact to consider because of the large quantities produced and the potential low quality of the water. Potential impacts of produced water disposal include groundwater contamination, increased turbidity, addition of nutrients (primarily nitrogen from blasting residuals), sedimentation, erosion, altered hydrology, loss of aquatic habitat, reduced water quality, and loss of soil productivity. The BLM, States, or the U.S. Environmental Protection Agency (EPA) regulate disposal of produced water. Where water treatment and disposal is allowed on NFS lands, the Forest Service regulates all surface-disturbing activities and determines the conditions that are necessary to protect surface resources including soil and water.

Practices Develop site-specific BMP prescriptions for the following practices, as appropriate or when required, using State BMPs, Forest Service regional guidance, land management plan direction, BMP monitoring information, and professional judgment.

- Prepare a water management plan that is consistent with land management plan desired conditions, goals, and objectives for water quality.
- Contain and limit the amount of produced water by recycling water through the mineral beneficiation process.
- Use produced water for a beneficial use, such as for mineral beneficiation or agriculture, where practicable.
- Discharge or otherwise dispose of produced water in compliance with the CWA and Safe Drinking Water Act, with appropriate approvals from the State and EPA.
- Re-inject produced water of suitable quality into acceptable underground reservoirs when authorized and appropriate.
- Avoid, minimize, or mitigate surface discharge effects including headcuts, stream crossing washouts, impoundments, channel stability, and flooding.
- Use applicable practices of BMP AqEco-3 (Ponds and Wetlands) when constructing ponds or impoundments to store produced water on the surface.

Min-8. Minerals Site Reclamation

Manual or Handbook

Reference FSM 2840 and FSM 2522.14.

Objective Reclaim minerals exploration and production sites and surrounding disturbed areas to as near to the predisturbed condition as is reasonably practicable after completion of exploration; production; or operations to avoid, minimize, or mitigate long-term adverse effects to soil, water quality, and riparian resources.

Explanation All lands disturbed by minerals exploration and production are required to be reclaimed to a condition consistent with the land management plan and applicable State soil and water quality requirements after all mining activities are completed. This practice will help ensure a systematic approach to reclaiming mineral, geothermal energy, and oil and gas operations. Although reclamation is usually thought of as the final step in managing mineral operations, reclamation measures must be considered during project planning; included in the approved plan, permit, or other authorization; and implemented during operations, as well as closure, to reduce potential resource impacts and facilitate the final reclamation effort.

Reclamation of abandoned mined lands sites poses additional problems to those associated with active sites. Typically these historical mineral operations were developed with little if any planning or operational controls to reduce environmental impacts. As a result, data about the environmental baseline—as well as the project facilities, equipment, and materials that are left onsite—may be minimal or absent. This information must be developed during analysis of the site so that restoration efforts are cost effective and achieve the desired results.

Practices Develop site-specific BMP prescriptions for the following practices, as appropriate or when required, using State BMPs, Forest Service regional guidance, land management plan direction, BMP monitoring information, and professional judgment.

All Activities

- Develop and implement a reclamation plan to rehabilitate and restore, to the extent practicable, the natural ecological components, structures, and processes consistent with land management plan desired conditions, goals, and objectives at minerals sites.
- Reclaim facilities, activities, and associated surface disturbance as soon as practicable after completion of their intended use.
- Establish the optimal timing and scheduling of reclamation operations.
 - ┆ Reclaim and stabilize facilities, disturbed areas, surface water diversion structures, and transport and storage areas before the end of seasonal shutdown so that they will function as designed to prevent adverse impacts to surface water from erosion and sedimentation.
- Sample and test the site to identify hazardous materials and associated areas that may be contaminated by petroleum products, reactive materials, or other chemicals.
- Use suitable measures to isolate, neutralize, remove, or treat hazardous or contaminated materials, including chemicals, reactive materials, acidic wastes, fuels, pit fluids, sediment, and human waste, consistent with applicable Federal, State, and local regulations to achieve applicable standards.
 - ┆ Remove or stabilize materials in settling ponds in a manner suitable for the volume, type, toxicity, and hazards of the materials.

-
- ┆ Require removal or encapsulation of waste material as necessary to avoid or minimize contaminating nearby waterbodies before operator abandons site or reclamation is accepted as final.
 - Remove facilities, materials, and equipment (including septic system) from NFS lands.
 - Use suitable measures to control or minimize erosion and sedimentation and ensure the stability of project components, including water drainage, diversion, conveyance, and storage facilities, as well as surface erosion and landslide control measures. (see BMP Veg-1 [Vegetation Management Planning], BMP Veg-2 [Erosion Prevention and Control], BMP Veg-3 [Aquatic Management Zones], BMP WatUses-4 [Water Diversions and Conveyances], BMP WatUses-5 [Dams and Impoundments], and BMP WatUses-6 [Dam Removal]).
 - Use suitable measures to divert, convey, and store surface water and groundwater away from mine (open pits or adits) and mine waste (tailings, waste rock, ore, and spent ore) facilities to the extent practicable to ensure stability and prevent formation of contaminated leachate or drainage.
 - ┆ Intercept and collect groundwater flows as needed to minimize potential for groundwater contamination and to maintain stability of reclaimed areas.
 - Install and seasonally monitor groundwater wells in areas where a risk of groundwater pollution exists (see BMP WatUses-2 [Water Wells for Production and Monitoring]).
 - Properly abandon, plug, and cap all drill holes, cores, and wells per applicable State or Federal requirements.
 - Stabilize or restore stream channels, wetlands, floodplains, and riparian areas to achieve desired conditions for aquatic ecosystem composition, structure, function, and processes and to re-establish or rehabilitate aquatic habitats to the extent practicable (see BMP AqEco-3 [Ponds and Wetlands] and BMP AqEco-4 [(Stream Channels and Shorelines])).
 - Construct passive or active water treatment facilities as needed.
 - Use suitable measures to control aquatic or wetland invasive species.
 - Back-fill and recontour disturbed areas, including exploratory trenches, pits, adits, or holes to the original contour, where practicable, or to an acceptable post-mining contour that blends with the surrounding topography to re-establish surface and subsurface hydrologic pathways to the extent practicable.
 - ┆ Stabilize benches around an open pit when backfilling is not practical.
 - Confirm physical stability of project components including design slopes and factors of safety.
 - Reconstruct, maintain, or decommission roads, trails, and staging areas consistent with land management plan desired conditions, goals, and objectives for the area (see Road Management BMPs).
 - Establish effective ground cover on disturbed sites to avoid or minimize accelerated erosion and soil loss.
 - ┆ Use suitable measures to prepare or treat subsoil and overburden to improve infiltration capacity on the site.
 - ┆ Spread topsoil or growth medium and woody material on the disturbed areas.
 - ┆ Test and use suitable measures to ameliorate topsoil or growth medium as necessary to achieve revegetation and ground cover objectives.
 - ┆ Use suitable measures to prepare the seedbed improve infiltration and roughen surface for seed catch.

- ↳ Use suitable species and establishment techniques to revegetate the site in compliance with local direction and requirements per FSM 2070 and FSM 2080 for vegetation ecology and prevention and control of invasive species.
- Perform mitigation required by the Operating Plan to protect water quality and quantity.
- Consider long-term management of the site and nearby areas to promote reclamation success.
 - ↳ Use suitable measures to limit human, vehicle, and livestock access to site as needed to protect reclaimed areas and allow for recovery of vegetation.
 - ↳ Monitor reclaimed areas for a period sufficient to demonstrate that measures to protect surface water and groundwater are functional and effective over the long term.
 - ↳ Implement interim operation, monitoring, and maintenance as required to protect reclaimed areas using suitable measures like fencing, road closure, or invasive species control until long-term stability, erosion control, and revegetation have been successfully established.
- Accept reclamation as complete when all reclamation measures are determined to be functional and effective.
- Implement long-term operation, monitoring, and maintenance activities as necessary for facilities, including roads, diversion ditches, dams, water treatment plants, fencing, gates, and signs, that must perform as designed for an indefinite period to prevent adverse impacts to water resources.

Geothermal Energy, Oil, and Gas Activities

- Reclaim well sites in a timely manner following well completion or plugging to avoid or minimize adverse effects to soil, water quality, and riparian resources.
- Permanently seal abandoned wells using appropriate protective measures in compliance with local and State requirements.
- Reclaim reserve pits to a condition that blends with the rest of the reclaimed pad area and restore the pit area to a safe and stable condition.

Resources for Minerals Management Activities

Aggregate Mining British Columbia Ministry of Energy and Mines. 2002. Aggregate operators best management practices handbook for British Columbia, Volume 1—Introduction and planning and Volume 2—Best management practices. Victoria, BC. Available at <http://142.32.76.167/mining/Aggregate/BMP/Pages/default.aspx>.

Ecology and Environment, Inc. 2006. User’s manual best management practices for gravel pits and the protection of surface water quality of Alaska. Anchorage, AK: Alaska Department of Environmental Conservation, Division of Water. 43 p. Available at http://www.dec.State.ak.us/water/wnpspc/pdfs/gravelpitbmp_guidance_final_063006.pdf.

Highland Engineering, Inc. 2009. Water quality best management practices for the aggregate mining industry. Duluth, GA: Georgia Construction Aggregate Association. 80 p. Available at <http://gcaa.org/gcaaweb/bmpmanual.pdf>.

Abandoned Mine Lands Colorado Department of Natural Resources. Best practices in abandoned mine land reclamation: the remediation of past mining activities. Denver, CO: Colorado Department of Natural Resources, Division of Minerals & Geology. 42 p. Available at <http://mining.state.co.us/pdfFiles/bmp.pdf>.

Ferris, F., and others. 1996. Handbook of western reclamation techniques. Denver, CO: U.S. Department of the Interior, Office of Surface Mining Reclamation and Enforcement. 500 p. Available at <http://www.techtransfer.osmre.gov/NTTMainSite/Library/hbmanual/westrecl.shtm>.

Hutchison, I.; Ellison, R., eds. 1992. Mine Waste Management. ISBN 9780873717465. CA: California Mining Association. 672 p.

International Network for Acid Prevention Web site, particularly the Completed Projects page. <http://www.inap.com.au/>.

O'Kane Consultants, Inc. 2003. Evaluation of long term performance of dry cover systems. OKC Report No. 684-02. Salt Lake City, UT: International Network for Acid Prevention. 190 p. Available at http://www.inap.com.au/completed_research_projects.htm.

Passive In-Situ Remediation of Acid Mine and Industrial Drainage (Piramid) Consortium. 2003. Engineering guidelines for the passive remediation of acidic and metalliferous mine drainage and similar wastewaters. United Kingdom: Piramid Consortium. Available at <http://www.eugris.info/DisplayResource.asp?ResourceID=4269>.

Skousen, J.; Rose, A.; Geidel, G.; Foreman, J.; Evans, R.; Hellier, W. 1998. A handbook of technologies for the avoidance and remediation of acid mine drainage. Morgantown, WV: The National Mineland Reclamation Center, Acid Drainage Technology Initiative. Available at <http://aciddrainage.com/publications.cfm>.

U.S. Department of the Interior, Bureau of Land Management. 2001. Draft solid minerals reclamation handbook. 136 p. Available at <http://www.fs.fed.us/geology/documents/blm.pdf>.

U.S. Environmental Protection Agency (EPA). 2000. Abandoned mine site characterization and cleanup handbook. EPA 910-B-00-001. Denver, CO: EPA Region 8, San Francisco; CA: EPA Region 9; and Seattle, WA: EPA Region 10. 120 p. Available at <http://www.epa.gov/superfund/policy/remedy/pdfs/amscch.pdf>.

Bonding Marks, M.B.; Buchta, T.; Newman, C.; Lentz, R.; and others. 2004. Training guide for reclamation bond estimation and administration for mineral plans of operation. Washington, DC: U.S. Department of Agriculture (USDA), Forest Service, Minerals and Geology. 133 p. Available at http://www.fs.fed.us/geology/mgm_minerals.html.

General Idaho Department of Lands. 1992. Best management practices for mining in Idaho. Boise, ID: Idaho Department of Lands. 150 p. Available at http://www.idl.idaho.gov/Bureau/Minerals/bmp_manual1992/bmp_index.htm.

Hard Rock Mining EPA, Region 10. 1999. EPA and hardrock mining—A sourcebook for industry in the Northwest and Alaska. EPA-910-R-99-016, draft. Seattle, WA.

USDA Natural Resources Conservation Service. National conservation practice standards—457 mine shaft and adit closing. Available at <http://www.nrcs.usda.gov/technical/standards/nhcp.html>.

Instream/Riparian

(Placer) Mining

Greystone. 1998. In-stream aggregate extraction and reclamation guidance document. Denver, CO: Colorado Department of Natural Resources, Division of Minerals and Geology. 99 p. Available at <http://mining.State.co.us/Policies.htm>.

McCulloch, R.B.; Ihie, B.; Ciliberti, V.; Williams, M. M. 1993. Montana Placer Mining BMPs: Guidelines for planning, erosion control, and reclamation. Special Publication 106. Butte, MT: Montana Bureau of Mines and Geology. 32 p. Available at http://www.mbm.mtech.edu/gmr/gmr-mines_exploration.asp or http://www.mbm.mtech.edu/mbmgcat/public/ListCitation.asp?pub_id=11696&.

Yukon Placer Secretariat. 2009. Guidebook of mitigation measures for placer mining in the Yukon. Whitehorse, Yukon: Yukon Placer Secretariat. 130 p. Available at <http://www.yukonplacersecretariat.ca/infocentre.html>.

Oil and Gas U.S. Department of the Interior, Bureau of Land Management; USDA Forest Service. 2007. Gold book—Surface operating standards and guidelines for oil and gas exploration and development. BLM/WO/ST-06/021+3071/REV 07. Denver, CO: U.S. Department of the Interior, Bureau of Land Management. 84 p. Available at http://www.blm.gov/wo/st/en/prog/energy/oil_and_gas/best_management_practices/gold_book.html.

University of Colorado Law School, Natural Resource Law Center. 2009. Intermountain oil and gas BMP project. Available at <http://www.oilandgasbmps.org/>.

Rangeland Management Activities

The purpose of this set of Best Management Practices (BMPs) is to avoid, minimize, or mitigate adverse effects to soil, water quality, and riparian resources that may result from rangeland management activities. Rangeland use includes grazing by cattle, sheep, goats, horses, and saddle stock used to manage the range and recreational stock. A primary purpose of the rangeland management program is to provide forage for commercial livestock operations. Grazing can also be a means of managing vegetation to meet other resource management objectives, such as fuels management, invasive species management, wildlife habitat improvement, and reduction of competing vegetation in plantations.

Three National Core BMPs are for Rangeland Management Activities. These BMPs are to be used when managing livestock grazing on National Forest System (NFS) lands. Each BMP is based on administrative directives that guide and direct the Forest Service planning and permitting of livestock grazing activities on NFS land. BMP Range-1 (Rangeland Management Planning) is a planning BMP for management of grazing allotments. BMP Range-2 (Rangeland Permit Administration) provides practices to be used when administering rangeland permits, including controlling overall livestock numbers, distribution, and season of use. BMP Range-3 (Rangeland Improvements) provides guidance for construction and maintenance of structural and nonstructural improvements and improvement of deteriorated rangeland soil and water resources.

States will be used in the rest of this resource category to signify both States and those tribes that have received approval from the U.S. Environmental Protection Agency (EPA) for treatment as a State under the Clean Water Act (CWA).

Rangeland Management BMPs	
Range-1	Rangeland Management Planning
Range-2	Rangeland Permit Administration
Range-3	Rangeland Improvements

Range-1. Rangeland Management Planning

Manual or Handbook

Reference Forest Service Manual (FSM) 2200 and Forest Service Handbook (FSH) 2209.13, chapter 90.

Objective Use the project-level National Environmental Policy Act (NEPA) planning process to develop measures to include in the Allotment Management Plan (AMP) to avoid, minimize, or mitigate adverse impacts to soil, water quality, and riparian resources from rangeland management activities.

Explanation Analysis of existing rangeland conditions and other resource values is conducted for each allotment as part of the project-level NEPA analysis and decision process for authorizing livestock grazing on NFS lands. The AMP is derived from the NEPA document and decision and is the primary document that guides implementation of land management plan direction for rangeland resources at the allotment (project) level. The AMP is included as part of the grazing permit and provides special management provisions, instructions, and terms and conditions for that permit.

Practices Develop site-specific BMP prescriptions for the following practices, as appropriate or when required, using State BMPs, Forest Service regional guidance, land management plan direction, BMP monitoring information, and professional judgment.

-
- Use applicable practices of BMP Plan-2 (Project Planning and Analysis) and BMP Plan-3 (Aquatic Management Zone [AMZ] Planning) when completing allotment management planning and analysis.
 - Validate land management plan grazing suitability decisions for the allotment.
 - Establish desired conditions for the allotment consistent with land management plan goals and objectives for water quality and AMZs.
 - Consider linkages between rangelands and soils, water quality, and riparian and aquatic systems when determining rangeland desired conditions.
 - Consider the ecological potential of riparian and aquatic systems when determining AMZ desired conditions.
 - Evaluate current rangeland condition and trends using accepted protocols.
 - Review past management within the allotment.
 - Determine management objectives and needs for livestock grazing and water resources affected by livestock grazing from management direction in the land management plan, biological opinions, or other binding direction and comparison of desired conditions with existing conditions.
 - Identify potential management strategies and rangeland and riparian improvement needs to maintain or move resources in the allotment toward achieving desired conditions.
 - Establish management requirements such as the season of use, number, kind, class of livestock, and the grazing systems.
 - Establish annual endpoint indicators of use (e.g., forage utilization, stubble height, streambank alteration, woody browse use) related to the desired conditions and triggers (thresholds) for management actions, such as modifying intensity, frequency, duration, and timing or excluding livestock use.
 - Set the indicator thresholds at levels suitable to maintain or achieve desired conditions for uplands, riparian areas, and aquatic ecosystems.
 - Develop a monitoring strategy and plan for adaptive management of the allotment.
 - Use accepted protocols to evaluate compliance with annual indicators of use and other land management plan standards.
 - Use accepted protocols to evaluate ecological status and trend, including water quality, aquatic habitats, and beneficial uses.
 - Document the following items from the project-level NEPA decision and analysis in the AMP, grazing permit, and Annual Operating Instructions (AOI):
 - Management objectives for livestock grazing and all resources affected by livestock grazing.
 - Management requirements for livestock grazing in the allotment.
 - Monitoring requirements to implement adaptive management in the allotment.
 - Schedules for rehabilitating rangelands that do not meet land management plan objectives, initiating range improvements, and maintaining existing improvements (see BMP Range-3 [Rangeland Improvements]).

Range-2. Rangeland Permit Administration

Manual or Handbook

Reference FSH 2209.13.

Objective Avoid, minimize, or mitigate adverse effects to soil, water quality, and riparian resources when managing rangeland vegetation and livestock grazing through administration and monitoring of grazing permits and AOI.

Explanation Improper grazing can adversely affect the watershed condition in several ways. Loss of effective ground cover in the uplands leads to increases in overland flow and peak runoff. Soil compaction, loss of ground cover, and reduced plant vigor in riparian areas decreases the ability of the riparian area to filter pollutants and function as a floodplain. Streambank trampling increases stream channel width/depth ratio, resulting in a change in stream type and a lowering of the water table. Wider and shallower streams have higher stream temperatures and lower dissolved oxygen content and are often unable to move the sediment load effectively, resulting in increased flooding and bank stress. Introducing sediment, nutrients, and pathogens into waterbodies from grazing can lower water quality. Managing livestock numbers, distribution, timing, and season of use can reduce the potential for these impacts.

A grazing permit is used to authorize livestock grazing on NFS lands. The permit delineates the area to be grazed and defines the number, kind, and class of livestock to be grazed and the season of use. The special terms and conditions in the permit contain required management practices from the project-level NEPA decision to avoid, minimize, or mitigate effects to water quality and other resource values. The permit and AMP also include monitoring requirements to evaluate compliance with standards and determine long-term trends in range condition.

AOI issued to the grazing permittee specify those annual actions needed to implement the management direction set forth in the project-level NEPA-based decision. The AOI identify the obligations of the permittee and the Forest Service and clearly articulate annual grazing management requirements, standards, and monitoring necessary to document compliance. The permittee carries out the terms and conditions of the permit under the immediate direction and supervision of the district ranger.

Practices Develop site-specific BMP prescriptions for the following practices, as appropriate or when required, using State BMPs, Forest Service regional guidance, land management plan direction, BMP monitoring information, and professional judgment.

- Conduct implementation and effectiveness monitoring as specified in the AMP.
- Monitor water quality, habitat, or other designated beneficial uses of water as necessary (e.g., 303(d) listed streams, required terms of Biological Opinions).
- Use monitoring results as an adaptive management feedback loop to revise, if necessary, annual grazing requirements in the AOI to account for current allotment conditions and trends (figure 2).
- Use results of annual compliance monitoring and periodic trend monitoring, as well as forage utilization by wildlife and recreational livestock, to determine allowable annual amount of livestock use to meet rangeland and AMZ desired conditions.
- Adjust livestock numbers, season of use, and distribution when monitoring and periodic assessments indicate consistent noncompliance with permit provisions.
 - Use suitable range management tools to alter livestock distribution.

Figure 2. Adaptive Management Process for management of range allotments.

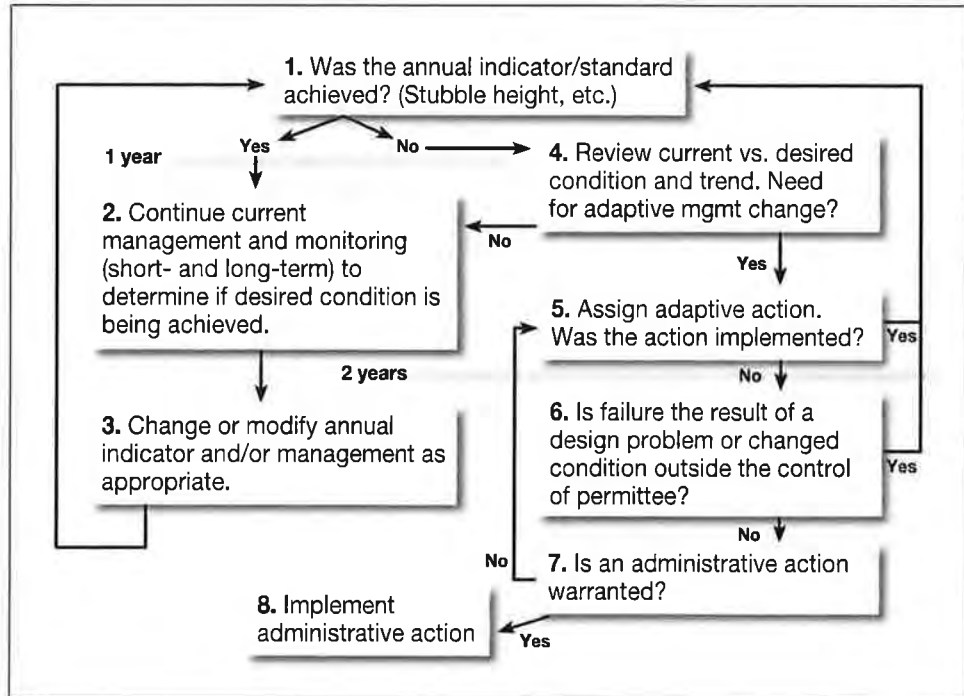

- Consider resting (placing an area in nonuse status for a period of time) a pasture or an allotment to allow for natural recovery of resource conditions.
- Document adaptive management actions such as allowable use, the planned sequence of grazing on the allotment, and any other operational changes in the AOI.
 - Modify the AMP and terms and conditions in the grazing permit for adaptive management actions that become consistent over a period of years or grazing rotations.
- Modify, cancel, or suspend the permit in whole or in part, as needed, to ensure proper use of the rangeland resource and protection of water quality.
 - Use permit authorities to change operations to avoid, minimize, or mitigate adverse effects to soil, water quality, and riparian resources when special circumstances (e.g., drought) occur.

Range-3. Rangeland Improvements

Manual or Handbook

Reference FSM 2240.

Objective Implement range improvements to maintain or improve soil, water quality, and riparian resources.

Explanation Rangeland improvements targeted at soil, water quality, and riparian resources are designed to protect or improve conditions of sensitive areas, streams, riparian areas, and wetlands and move these resources toward desired conditions. Improvements should emphasize protecting the beneficial uses in these areas. Improvements may supplement changes in annual use levels, seasonal use, distribution, and number, or other administrative actions.

Development and maintenance of rangeland improvements can be the responsibility of either the permittee or the Forest Service. The district ranger will ensure that the permittee is involved as a cooperator in rangeland improvements. The permittee may construct or maintain improvements under Forest Service direction, or Forest Service crews or contractors may construct or maintain improvements.

Practices Develop site-specific BMP prescriptions for the following practices, as appropriate or when required, using State BMPs, Forest Service regional guidance, land management plan direction, BMP monitoring information, and professional judgment.

- Identify and evaluate range improvement needs for soil, water quality, and riparian resources during watershed analysis, watershed condition assessment, project-level rangeland NEPA, or other assessment efforts.
- Include and schedule improvement actions and maintenance in the AMP and grazing permit.
- Design, implement, and maintain structural and nonstructural range improvements to achieve or sustain desired conditions for the rangeland, soils, water quality, and riparian resources in the allotment as determined in the project-level NEPA decision.
 - ┆ Use rangeland vegetation species and establishment techniques suitable to the project site and objectives and consistent with local direction and requirements per FSM 2070 and FSM 2080 for vegetation ecology and prevention and control of invasive species.
 - ┆ Use applicable Chemical Use Activities BMPs when using chemicals to treat rangeland vegetation and control invasive species.
 - ┆ Use applicable practices of BMP Veg-8 (Mechanical Site Treatment) when implementing mechanical treatments of rangeland vegetation.
 - ┆ Use applicable practices of BMP Fire-2 (Use of Prescribed Fire) when using prescribed fire to improve rangeland vegetation and conditions.
 - ┆ Use applicable practices of BMP AqEco-3 (Ponds and Wetlands) and BMP AqEco-4 (Stream Channels and Shorelines) for improvement activities that involve waterbodies.
 - ┆ Use applicable practices of BMP WatUses-3 (Administrative Water Developments) when developing water sources for livestock watering.

Resources for Rangeland Management Activities

Best Management

Practices Harmon, W., ed. 1999. Best management practices for grazing. Helena, MT: Montana Department of Natural Resources and Conservation. 28 p.

Meitl, J.; Maguire, T., eds. 2003. Compendium of best management practices to control polluted runoff: A source book. Boise, ID: Idaho Department of Environmental Quality. Available at http://www.deq.State.id.us/water/data_reports/surface_water/nps/reports.cfm#bmps.

U.S. Department of Agriculture (USDA), Natural Resources Conservation Service (NRCS). National conservation practice standards—383 fence. Available at <http://www.nrcs.usda.gov/technical/standards/nhcp.html>.

U.S. Environmental Protection Agency. 2003. National management measures for the control of nonpoint source pollution from agriculture. EPA 841-B-03-004. Washington, DC. Available at http://water.epa.gov/polwaste/nps/agriculture/agmm_index.cfm.

Wyoming Department of Environmental Quality (WDEQ). 1997. Best management practices for grazing. Cheyenne, WY: Wyoming Department of Environmental Quality, Water Quality Division. 17 p. Available at <http://deq.State.wy.us/wqd/watershed/Downloads/NPS%20Program/92602.pdf>.

Ecological Site

Description

USDA NRCS. Ecological site description (ESD) system for rangeland and forestland. Database. Available at <http://esis.sc.egov.usda.gov/Welcome/pgESDWelcome.aspx>

Proper Functioning

Condition

Pritchard, D.; and others. 1998. Guide to assessing proper functioning condition and the supporting science for lotic areas. TR1737-15 Riparian Area Management. Denver, CO: U.S. Department of the Interior, Bureau of Land Management; USDA Forest Service, USDA NRCS. 126 p. Available at <http://www.blm.gov/nstc/library/techref.htm>.

Pritchard, D.; and others. 1999 (Rev. 2003). Guide to assessing proper functioning condition and the supporting science for lentic areas. TR1737-16 Riparian Area Management. Denver, CO: U.S. Department of the Interior, Bureau of Land Management; USDA Forest Service, USDA NRCS. 110 p. Available at <http://www.blm.gov/nstc/library/techref.htm>.

Rangeland Health

Assessment

Pellant, M.; Shaver, P.; Pyke, D.A.; Herrick, J.E. 2005. Interpreting indicators of rangeland health, version 4. Technical Guide 1734-6. Denver, CO: U.S. Department of the Interior, Bureau of Land Management, National Science and Technology Center. Available at <http://www.blm.gov/nstc/library/techref.htm>.

Riparian Area Grazing

Management

Clary, W.P.; Webster, B.F. 1989. Managing grazing of riparian areas in the Intermountain Region. Gen. Tech. Rep. INT-263. Ogden, UT: USDA Forest Service, Intermountain Research Station. 11 p. Available at http://www.fs.fed.us/rm/pubs_int/int_gtr263.pdf.

Wyman, S.; Bailey, D.; Borman, M.; Cote, S.; and others. 2006. Riparian area management: Grazing management processes and strategies for riparian-wetland areas. Technical Reference 1737-20. Denver, CO: U.S. Department of the Interior, Bureau of Land Management, National Science and Technology Center. 105 p. Available at <http://www.blm.gov/nstc/library/techref.htm>.

Riparian Area Monitoring

Burton, T.A.; Smith, S.J.; Cowley, E.R. 2011. Riparian area management: Multiple indicator monitoring (MIM) of stream channels and aquatic vegetation. Technical Reference 1737-23. Denver, CO: U.S. Department of the Interior, Bureau of Land Management. 155 p. Available at <http://www.blm.gov/nstc/library/techref.htm>.

Stubble Height

University of Idaho, Stubble Height Review Team. 2004. Stubble height study report Contribution No. 986. Moscow, ID: University of Idaho, Forest, Wildlife and Range Experiment Station. Available at http://www.cnrhome.uidaho.edu/documents/Stubble_Height_Report.pdf?pid=74895&doc=1.

Recreation Management Activities

The purpose of this set of Best Management Practices (BMPs) is to avoid, minimize, or mitigate adverse effects to soil, water quality, and riparian resources that may result from recreation activities. An objective of the Forest Service recreation program is to provide nonurbanized outdoor recreation opportunities in natural appearing forest and rangeland settings. Recreation activities on National Forest System (NFS) lands take place at developed and undeveloped sites or are dispersed across broad areas.

Twelve National Core BMPs are in the Recreation Management Activities category. These BMPs are to be used when managing recreation use and facilities on NFS lands. BMP Rec-1 (Recreation Planning) is a planning BMP for recreation activities at the land management plan scale and project scale. BMP Rec-2 (Developed Recreation Sites) provides practices for sites that are designed and constructed to provide facilities for users. BMP Rec-3 (Dispersed Use Recreation) covers dispersed recreation, including user-created sites and frequently used areas. BMP Rec-4 (Motorized and Nonmotorized Trails) provides practices for construction, operation, and maintenance of the designated trail system. BMP Rec-5 (Motorized Vehicle Use Areas) covers areas designated for cross-country motor vehicle use. BMP Rec-6 (Pack and Riding Stock Use Areas) has practices for trailheads, corrals, and other areas where pack and riding stock use is concentrated. BMP Rec-7 (Over-Snow Vehicle Use) has direction for snowmobile trails and other over-snow vehicle uses. BMP Rec-8 (Watercraft Launches) is for boat launches on lakes and rivers. BMP Rec-9 (Recreation Special Use Authorizations) provides direction for recreation residences, outfitters and guides, and other recreation activities operated under special use authorizations. BMP Rec-10 (Ski Runs and Lifts), BMP Rec-11 (Ski Area Snowmaking), and BMP Rec-12 (Ski Area Facilities) provide practices for ski areas.

States will be used in the rest of this resource category to signify both States and those tribes that have received approval from the U.S. Environmental Protection Agency (EPA) for treatment as a State under the Clean Water Act (CWA).

Recreation Activities BMPs	
Rec-1	Recreation Planning
Rec-2	Developed Recreation Sites
Rec-3	Dispersed Use Recreation
Rec-4	Motorized and Nonmotorized Trails
Rec-5	Motorized Vehicle Use Areas
Rec-6	Pack and Riding Stock Use Areas
Rec-7	Over-Snow Vehicle Use
Rec-8	Watercraft Launches
Rec-9	Recreation Special Use Authorizations
Rec-10	Ski Runs and Lifts
Rec-11	Ski Area Snowmaking
Rec-12	Ski Area Facilities

Rec-1. Recreation Planning

Manual or Handbook

Reference Forest Service Manual (FSM) 2310; FSM 2332; FSM 2333; FSM 2341; and Forest Service Handbook (FSH) 2309.18, chapter 10.

Objective Use the applicable recreation planning process to develop measures to avoid, minimize, or mitigate adverse effects to soil, water quality, and riparian resources during recreation activities.

Explanation Recreation activities occur in a variety of settings and intensities on NFS lands, including at developed or undeveloped recreation sites or dispersed across broad areas. The objective of recreation planning is to provide for the current and future outdoor recreation demands while integrating recreation use with other resource concerns. The Recreation Opportunity Spectrum (ROS) system provides a framework for stratifying and defining classes of outdoor recreation opportunities along a continuum that combines physical, biological, social, and management conditions for providing a variety of recreational experiences across an array of settings. ROS is management tool that integrates social considerations and biophysical components of a landscape to achieve multiple social and natural resource objectives. ROS classes, and standards and guidelines, are established in the land management plan. ROS class primarily guides management of recreation use.

Recreation facilities on NFS lands are constructed and maintained by the Forest Service or others under a Forest Service authorization. These facilities include developed recreation sites, organization camps, recreation residence tracts, motorized and nonmotorized trails and facilities, dispersed recreation sites, and winter sports centers such as alpine ski areas. Some small facilities are constructed and managed by Forest Service personnel using agency design criteria and management guidelines as incorporated into project plans. Facilities developed by others on NFS lands are administered through special use authorizations issued by the Forest Service to public or private agencies, groups, or individuals. Special use authorizations must include terms and conditions to protect the environment and otherwise comply with the requirements of the Federal Land Policy and Management Act of 1976 (43 U.S.C. 1752).

Practices Develop site-specific BMP prescriptions for the following practices, as appropriate or when required, using State BMPs, Forest Service regional guidance, land management plan direction, BMP monitoring information, and professional judgment.

Land Management Plans

- Consider the beneficial and adverse effects of recreation use on water quality and watershed condition when developing desired conditions, ROS classes, and management direction for the plan area.
 - ┆ Identify areas where the adverse effects of recreational use to water quality and watershed condition outweigh the benefits.
- Include design criteria, standards, and guidelines for recreational use to avoid, minimize, or mitigate adverse effects to soil, water quality, and riparian resources.

Project or Activity Planning

- Use applicable practices of BMP Plan-2 (Project Planning and Analysis) and BMP Plan-3 (Aquatic Management Zone [AMZ] Planning) when planning recreation projects.
- Select site locations for recreation facilities that avoid or minimize the potential for adverse effects to water quality and riparian resources.
- Design the capacity and layout of the recreation site to be consistent with land management plan desired conditions, goals, and objectives for soil, water quality, and riparian resources.

- Consider capacity and patterns of use at a site when determining measures to avoid, minimize, or mitigate adverse effects from recreational use to soil, water quality, and riparian resources.
- Use applicable practices of BMP Fac-2 (Facility Construction and Stormwater Control) to incorporate suitable erosion and stormwater controls in the project design.
- Use applicable practices of BMPs for access roads and water, sanitation, and solid waste systems at recreation sites (see Roads Management Activities BMPs and Facilities and Nonrecreation Special Uses Management Activities BMPs) as needed.
- Use applicable practices of BMP Road-10 (Equipment Refueling and Servicing) for recreation sites where vehicles or other equipment will be stored and maintained.
- Use applicable practices of BMP Fac-6 (Hazardous Materials) for management of hazardous materials at recreation sites.
- Determine instream flow needs to minimize damage to scenic and aesthetic values, fish and wildlife habitat, and to otherwise protect the environment where the operation of the recreation site would modify existing streamflow regimes (see BMP WatUses-1 [Water Uses Planning]).

Rec-2. Developed Recreation Sites

Manual or Handbook

Reference FSM 2332, FSM 2333, and FSM 2334.

Objective Avoid, minimize, or mitigate adverse effects to soil, water quality, and riparian resources at developed recreation sites by maintaining desired levels of ground cover, limiting soil compaction, and minimizing pollutants entering waterbodies.

Explanation Developed recreation sites provide amenities for user comfort and can be located in motorized or nonmotorized settings. Oftentimes these areas concentrate high volumes of use into relatively small areas and may be located on or near waterbodies, thereby increasing the potential for water quality degradation. Potential pollutants generated by use at developed recreation sites include, but are not limited to, human and animal waste; solid wastes (trash); petroleum products; and other hazardous substances. In addition, continuous or recurring use at one site can cause excessive soil compaction; damage to vegetation, wetlands, and riparian areas; and erosion and sediment transport from the site.

Practices Develop site-specific BMP prescriptions for the following practices, as appropriate or when required, using State BMPs, Forest Service regional guidance, land management plan direction, BMP monitoring information, and professional judgment.

- Use applicable practices of BMP Fac-2 (Facility Construction and Stormwater Control) to construct and maintain appropriate erosion control and stormwater management measures to avoid or minimize adverse effects to water quality from pollutant runoff at the site.
- Use applicable practices of Roads Management Activities BMPs for construction and maintenance of access roads.
- Use applicable practices of BMP Roads-9 (Parking and Staging Areas) for trailheads and other parking areas at developed recreation sites.
- Use applicable practices of BMP Fac-3 (Potable Water Supply Systems), BMP Fac-4 (Sanitation Systems), and BMP Fac-5 (Solid Waste Management) for water, sanitation, and solid waste systems at developed recreation sites.

-
- Evaluate and adjust design capacity of the site when recreation use is causing adverse effects to water quality or riparian resources.
 - Provide hardened campsites located sufficiently far from surface waterbodies to provide an adequate vegetative filter strip to avoid or minimize sediment delivery (see BMP Plan-3 [AMZ Planning]).
 - Consider potential impacts to soils, water quality, and riparian resources when establishing recreation site use periods.
 - Use suitable measures to avoid or minimize overuse on sensitive areas.
 - Use suitable public relations, information, and enforcement tools to encourage the public to conduct their activities in a manner that will avoid, minimize, or mitigate adverse effects to soil, water quality, and riparian resources.
 - Provide information on the location of the nearest RV (recreational vehicle) wastewater disposal station.
 - Periodically evaluate the condition of soil, water quality, and riparian resources at and near developed sites to identify signs of insufficient ground cover, detrimental soil compaction, excessive runoff, sedimentation, or chemical or pollutant release by recreationists.
 - Relocate trails, parking areas, campsites, play areas, or water distribution points that are causing offsite resource damage.
 - Redesign and reconstruct, or close and rehabilitate, areas of recreation sites that exhibit signs of overuse.
 - Use suitable measures to restrict access, when necessary, to nearby wetlands and riparian areas that show signs of excessive damage from recreation use to allow for vegetative recovery.
 - Rehabilitate unwanted user-created trails and sites within the developed recreation site and employ suitable measures to discourage their creation and use (see BMP Fac-10 [Facility Site Reclamation]).
 - Use applicable practices of BMP Fac-10 (Facility Site Reclamation) to reclaim the developed recreation site after the need for it ends.

Rec-3. Dispersed Use Recreation

Manual or Handbook

Reference FSM 2330.

Objective Avoid, minimize, or mitigate adverse effects to soil, water quality, and riparian resources by managing dispersed activities and undeveloped sites to maintain ground cover, maintain soil quality, control runoff, and provide needed sanitary facilities to minimize the discharge of nonpoint source pollutants and maintain streambank and riparian area integrity.

Explanation Dispersed recreation use takes many forms, both motorized and nonmotorized, across a range of forest and grassland settings. Many dispersed uses and user-created undeveloped sites are located adjacent to or provide easy access to lakes and rivers and lack the design and amenities offered at developed sites to mitigate effects of use. As a result, the impacts of dispersed recreation use on soils, water quality, and riparian resources can be greater than impacts at developed sites. Nonpoint source pollution from dispersed recreation use includes human and animal wastes, petroleum products, other hazardous substances, streambank disturbance, stream channel alteration, and sediment eroded from the site.

-
- Practices** Develop site-specific BMP prescriptions for the following practices, as appropriate or when required, using State BMPs, Forest Service regional guidance, land management plan direction, BMP monitoring information, and professional judgment.
- Use suitable public relations and information tools and enforcement measures to encourage the public to conduct dispersed recreation activities in a manner that will avoid, minimize, or mitigate adverse effects to soil, water quality, and riparian resources.
 - Designate locations and crossings for allowable motorized vehicle use within the AMZ as part of travel management (see BMP Plan-3 [AMZ Planning] and BMP Road-1 [Travel Management and Analysis]).
 - ┆ Use suitable measures to limit crossings and restrict motorized use within the AMZ to the extent practicable.
 - Manage use to avoid, minimize, or mitigate adverse effects to soil, water quality, and riparian resources.
 - ┆ Develop and designate campsites in appropriate locations.
 - ┆ Limit group size and periods of use (numbers of consecutive days, time of day, etc.).
 - Consider providing primitive sanitation facilities in areas where perpetual concentrated dispersed recreation use is causing adverse effects to soil, water quality, or riparian resources (see BMP Fac-4 [Sanitation Systems]).
 - Close and rehabilitate dispersed or undeveloped sites that are causing unacceptable adverse effects on soil, water quality, and riparian resources (see BMP Fac-10 [Facility Site Reclamation]).
 - ┆ Manage site to mitigate adverse effects of use when closure is not practicable.

Rec-4. Motorized and Nonmotorized Trails

Manual or Handbook

Reference FSM 2353, FSH 2309.18, FSM 7715.5, FSM 7723, and EM (Engineering Management) 7720-104.

Objective Avoid, minimize, or mitigate adverse effects to soil, water quality, and riparian resources by controlling soil erosion, erosion of trail surface materials, and water quality problems originating from construction, maintenance, and use of motorized and nonmotorized trails.

Explanation The Forest Service manages about 133,000 miles of trails that are part of the designated transportation system. Only portions of these trails are open to motorized vehicle use. Almost all NFS trails serve nonmotorized users, including hikers, bicyclists, and equestrians, alone or in some combination with motorized uses.

Trail construction, maintenance, and use by motorized vehicles and human or stock traffic can adversely affect water quality by increased sediment delivery and contamination from vehicle fluids and human and animal wastes to nearby waterbodies. Compaction of the trail surface limits water infiltration, which can lead to concentrated runoff on the trail surface. Concentrated runoff on trails lacking adequate drainage causes erosion of the trail surface and can transport sediment and other pollutants directly into waterbodies if not filtered. Heavy tread, foot, or hoof traffic can loosen some trail surface materials, making them more susceptible to erosion.

Trails open to motorized use are designated during the travel management process and depicted on the Motor Vehicle Use Map (MVUM). Motorized use is designated by allowed vehicle class and, if appropriate, time of year, with the objective of minimizing damage to soil and water resources.

-
- Practices** Develop site-specific BMP prescriptions for the following practices, as appropriate or when required, using State BMPs, Forest Service regional guidance, land management plan direction, BMP monitoring information, and professional judgment.
- Use applicable Road Management Activities BMPs for construction, operation, and maintenance of motorized trails.
 - Locate or relocate trails to conform to the terrain, provide suitable drainage, provide adequate pollutant filtering between the trail and nearby waterbodies, and reduce potential adverse effects to soil, water quality, or riparian resources.
 - Avoid sensitive areas, such as riparian areas, wetlands, stream crossings, inner gorges, and unstable areas to the extent practicable.
 - Use suitable measures to mitigate trail impacts to the extent practicable where sensitive areas are unavoidable.
 - Use suitable measures to hydrologically disconnect trails from waterbodies to the extent practicable.
 - Design, construct, and maintain trail width, grades, curves, and switchbacks suitable to the terrain and designated use.
 - Use applicable practices of BMP Fac-2 (Facility Construction and Stormwater Control) for control of erosion and stormwater when constructing trails.
 - Install and maintain suitable drainage measures to collect and disperse runoff and avoid or minimize erosion of trail surface and adjacent areas.
 - Use and maintain surfacing materials suitable to the trail site and use to withstand traffic and minimize runoff and erosion.
 - Pay particular attention to areas where high wheel slip (curves, acceleration, and braking) during motorized use generates loose soil material.
 - Design stream crossings to use the most cost-efficient structure consistent with resource protection, facility needs, and types of use and safety obligations (see BMP Road-2 [Road Location and Design] and BMP Road-7 [Stream Crossings]).
 - Designate season of use to avoid periods when trail surfaces are particularly prone to unacceptable erosion, rutting, or compaction.
 - Designate class of vehicle and type of nonmotorized uses (e.g., hiking, bicycling, and equestrian uses) suitable for the trail width, location, waterbody crossings, and trail surfaces to avoid or minimize adverse effects to soil, water quality, or riparian resources.
 - Monitor trail condition at regular intervals to identify drainage and trail surface maintenance needs to avoid, minimize, or mitigate adverse effects to soil, water quality, and riparian resources.
 - Manage designated trails to mitigate adverse effects to soil, water quality, and riparian resources from over-use when closure and rehabilitation is not practicable or desired.
 - Change designated vehicle class and season-of-use period as necessary.
 - Close and rehabilitate unauthorized trails that are causing adverse effects on soil, water quality, and riparian resources (see BMP Fac-10 [Facility Site Reclamation]).

Equestrian Trails

- Plan trails so that equestrian users will go slower in sensitive areas to protect trail tread.
- Use a trail design that constricts equestrian users to a designated tread, where practicable, to minimize the tendency of stock to create braided or multiple trail treads.
- Provide reasonable access to stock water at suitable intervals along designated equestrian trails where practicable.

Rec-5. Motorized Vehicle Use Areas

Manual or Handbook

Reference FSM 2353.28, FSH 2309.18 23.22, and FSM 7716.

Objective Avoid, minimize, or mitigate adverse effects to soil, water quality, and riparian resources at motorized vehicle use areas by managing activities to maintain ground cover, maintain soil quality, and control runoff to minimize discharge of nonpoint source pollutants and maintain streambank and riparian area integrity.

Explanation Forest Service policy recognizes that motor vehicles are a legitimate and appropriate way for people to use the national forests and grasslands—in the right places and with proper management. Unrestricted cross-country travel by motor vehicles increases soil erosion and adversely affects water quality. The first vehicle driving across a particular piece of ground may not harm the land. After many more vehicles have crossed the same path, however, the result may be a user-created route and lasting impacts to soil, water quality, and riparian resources. The proliferation of user-created roads and trails is a major challenge on many national forests and grasslands. User-created routes, in general, are not located, designed, or maintained to avoid, minimize, or mitigate adverse effects to soil, water quality, or riparian resources. The Travel Management Rule adopted in 2005 restricts motor vehicle use to designated roads, trails, and areas on NFS lands to better manage motor vehicle use and protect NFS resources.

Limited areas on NFS lands open to cross-country motorized use may be designated during the travel management process and, if designated, are depicted on the MVUM. These areas should have natural resource characteristics that are suitable for motor vehicle use, or should be so altered by past actions that motor vehicle use might be appropriate. Motorized use is designated by allowed vehicle class and, if appropriate, by time of year, with the objective of minimizing damage to soil and watershed resources. Limited cross-country use of motorized vehicles within a specified distance from designated routes may be allowed for purposes of dispersed camping and big game retrieval. After motor vehicle use areas are established on a national forest or grassland, motor vehicle use outside of these designated areas is prohibited.

Practices Develop site-specific BMP prescriptions for the following practices, as appropriate or when required, using State BMPs, Forest Service regional guidance, land management plan direction, BMP monitoring information, and professional judgment.

- Use suitable public relations and information tools and enforcement measures to encourage the public to conduct motorized vehicle use activities within designated areas in a manner that will avoid, minimize, or mitigate adverse effects to soil, water quality, and riparian resources.
- Locate and maintain designated motor vehicle use areas to avoid or minimize adverse effects on soil, water quality, and riparian resources.

-
- ↳ Consider suitability of slopes, access points, vegetation cover and similar features, and soil characteristics such as erodibility and texture, for motor vehicle use.
 - ↳ Favor areas that are naturally barren or have been significantly altered by past motorized vehicle use or land use (e.g., gravel pits, reservoir bathtub rings, or lake bottoms).
 - ↳ Avoid areas of sensitive soils and floodplains.
 - ↳ Manage hillclimb areas to minimize length and steepness.
 - ↳ Avoid concentration of motor vehicle use in bowl-shaped areas above draws that are susceptible to erosion.
 - Designate season-of-use periods to avoid periods when soils are particularly prone to unacceptable erosion, rutting, or compaction.
 - Designate class of vehicle suitable for the soil and terrain of the designated motor vehicle use area to avoid or minimize adverse effects to soil, water quality, or riparian resources.
 - Clearly delineate and mark designated motor vehicle use areas in the field where practicable.
 - Monitor designated motor vehicle use areas at regular intervals to identify drainage and soil cover maintenance needs to avoid, minimize, or mitigate adverse effects to soil, water quality, and riparian resources.
 - Manage designated motor vehicle use areas, particularly hillclimb areas, to mitigate adverse effects to soil, water quality, and riparian resources from over-use when closure and rehabilitation is not practicable or desired.
 - ↳ Change designated vehicle class and season-of-use period as necessary.
 - ↳ Schedule use periods of hillclimbs to allow for rehabilitation.
 - ↳ Rotate hillclimb areas to extend the lifespan of a hillclimb.
 - Close and rehabilitate designated motor vehicle use areas that are causing unacceptable adverse effects to soil, water quality, and riparian resources (see BMP Fac-10 [Facility Site Reclamation]).
 - Place suitable restrictions on motor vehicle use off designated routes for dispersed camping and big game retrieval to avoid, minimize, or mitigate adverse effects on soil, water quality, and riparian resources.
 - ↳ Avoid riparian, wetland, or other identified sensitive resource areas where practicable.
 - ↳ Designate stream-crossing sites to the extent practicable.

Rec-6. Pack and Riding Stock Use Areas

Manual or Handbook

Reference FSH 2309.18 22.43 and 23.12.

Objective Avoid, minimize, or mitigate adverse effects to soil, water quality, and riparian resources at pack and riding stock use areas by managing activities to maintain ground cover, maintain soil quality, control runoff, and provide needed sanitary facilities to minimize discharge of nonpoint source pollutants and maintain streambank and riparian area integrity.

Explanation Pack and riding stock can affect soil, water quality, and riparian resources while on trails and at campsites, watering areas, and loading areas. The level of use at a site can range from single-day use by one or more riders at a remote site to large developed campsites and trails used repeatedly

by outfitter and guide operations, commercial stock operators, and other recreational users. Use may take place in the general forest area or in designated wilderness areas. Access areas, in general, are used for loading and unloading, parking, and turning around vehicles and stock trailers. Potential impacts include loss of ground cover, soil compaction, rutting, or puddling, and increased erosion, streambank trampling, spread of weeds, and water contamination from animal waste.

Practices Develop site-specific BMP prescriptions for the following practices, as appropriate or when required, using State BMPs, Forest Service regional guidance, land management plan direction, BMP monitoring information, and professional judgment.

- Use suitable public relations and information tools and enforcement measures to encourage the public to conduct activities on trails and at stock use areas in a manner that will avoid, minimize, or mitigate adverse effects to soil, water quality, and riparian resources.
 - Provide information on proper stock tethering, watering, and manure handling and disposal techniques.
- Use applicable practices of BMP Rec-2 (Developed Recreation Sites) when designing, constructing, and maintaining developed areas for pack and riding stock use.
- Install simple temporary holding facilities in both wilderness and nonwilderness areas.
 - Evaluate soils and vegetation for vulnerability of damage or disruption from stock use when choosing holding facility sites.
 - Locate corrals and tethering areas at a suitable distance from waterbodies to avoid or minimize adverse effects to soil, water quality, and riparian resources.
- Designate specific watering locations on streams, ponds, and lakes to avoid or minimize general use along streambanks or shorelines.
- Provide designated watering areas at developed stock use areas where practicable.
 - Surface the areas around water hydrants, troughs, and stock tanks using suitable materials to mitigate trampling effects.
 - Locate designated watering areas at a suitable distance from waterbodies to avoid or minimize adverse effects to soil, water quality, and riparian resources.
- Provide manure disposal bins at developed pack and riding stock use areas.
 - Locate manure receptacles on level ground at a suitable distance to provide adequate pollutant filtering between the accumulated manure and nearby waterbodies.
 - Provide positive drainage to prevent puddles from forming within and around the manure receptacle.
 - Provide tools (e.g., wheelbarrows, rakes, and bags) to facilitate manure cleanup.
 - Periodically remove or treat accumulated animal waste to avoid or minimize contaminating waterbodies.
- Monitor pack and riding stock use areas at regular intervals to identify drainage and ground surface maintenance needs to avoid, minimize, or mitigate adverse effects to soil, water quality, and riparian resources.
- Manage pack and riding stock use areas to mitigate adverse effects to soil, water quality, and riparian resources from over-use when closure and rehabilitation is not practicable or desired.
- Close and rehabilitate pack and riding stock use areas that are causing adverse effects on soil, water quality, and riparian resources (see BMP Fac-10 [Facility Site Reclamation]).

Rec-7. Over-Snow Vehicle Use

Manual or Handbook

Reference FSM 7718.

Objective Avoid, minimize, or mitigate adverse effects to soil, water quality, and riparian resources from over-snow vehicle use.

Explanation An over-snow vehicle is a motor vehicle that is designed for use over snow and that runs on a track or tracks and a ski or skis, while in use over snow. Over-snow vehicles include snowmobiles, snow cats, and snow grooming machines. Snowmobiles and snow cats are used for access and for recreational activities. Snow grooming machines are used to prepare snow on trails for downhill or cross-country skiing or snowmobile use.

An over-snow vehicle traveling over snow results in different impacts to soil and water resources than do motor vehicles traveling over the ground. Unlike other motor vehicles traveling cross-country, over-snow vehicles generally do not create a permanent trail or have direct impact on soil and ground vegetation when snow depths are sufficient to protect the ground surface. Emissions from over-snow vehicles, particularly two-stroke engines on snowmobiles, release pollutants like ammonium, sulfate, benzene, polycyclic aromatic hydrocarbons, and other toxic compounds that are stored in the snowpack. During spring snowmelt runoff, these accumulated pollutants are released and may be delivered to surrounding waterbodies. In addition, over-snow vehicles that fall through thin ice can pollute waterbodies.

Use of NFS lands and trails by over-snow vehicles may be allowed, restricted, or prohibited at the discretion of the local line officer.

Practices Develop site-specific BMP prescriptions for the following practices, as appropriate or when required, using State BMPs, Forest Service regional guidance, land management plan direction, BMP monitoring information, and professional judgment.

- Use suitable public relations and information tools and enforcement measures to encourage the public to conduct cross-country over-snow vehicle use on trails in a manner that will avoid, minimize, or mitigate adverse effects to soil, water quality, and riparian resources.
 - ┆ Provide information on the hazards of running over-snow vehicles on thin ice.
 - ┆ Provide information on effects on over-snow vehicle emissions on air quality and water quality.
- Use applicable practices of BMP Rec-4 (Motorized and Nonmotorized Trails) when locating, designing, constructing, and maintaining trails for over-snow vehicle use.
- Allow over-snow vehicle use cross-country or on trails when snow depths are sufficient to protect the underlying vegetative cover and soil or trail surface.
 - ┆ Specify the minimum snow depth for each type or class of over-snow vehicle to protect underlying resources as part of any restrictions or prohibitions on over-snow use.
 - ┆ Specify season of use to be at times when the snowpack is expected to be of suitable depth.
 - ┆ Specify over-snow vehicle class suitable for the expected snowpack and terrain or trail conditions.
- Use and enforce closure orders to mitigate effects when adverse effects to soil, water quality, or riparian resources are occurring.

-
- Use applicable practices of BMP Rec-2 (Developed Recreation Sites) when constructing and operating over-snow vehicle trailheads, parking, and staging areas.
 - ┆ Use suitable measures to trap and treat pollutants from over-snow vehicle emissions in snowmelt runoff or locate the staging area at a sufficient distance from nearby waterbodies to provide adequate pollutant filtering.

Rec-8. Watercraft Launches

Manual or Handbook

Reference FSM 2334.24 and FSM 2335.1.

Objective Avoid, minimize, or mitigate adverse effects to soil, water quality, and riparian resources from facilities at locations used to launch and retrieve watercraft.

Explanation Facilities related to the use and enjoyment of watercraft (nonpowered boats, powerboats, personal watercraft, etc.) can affect water quality. These facilities include boat ramps, roads, and parking facilities, sanitation facilities, marinas, and other infrastructure. The immediate proximity and connection of the facility to the water's edge provides a direct pathway for pollutants to enter the waterbody.

Practices Develop site-specific BMP prescriptions for the following practices, as appropriate or when required, using State BMPs, Forest Service regional guidance, land management plan direction, BMP monitoring information, and professional judgment.

- Use suitable public relations and information tools and enforcement measures to encourage the public to conduct boating and related activities in a manner that will avoid, minimize, or mitigate adverse effects to soil, water quality, and riparian resources.
 - ┆ Provide information on measures for preventing the spread of aquatic invasive species, proper fish cleaning and disposal of fish waste, proper disposal of solid waste while boating, and preventing wake damage to shorelines.
- Locate and design watercraft launch sites to avoid, minimize, or mitigate adverse effects to soil, water quality, and riparian resources.
 - ┆ Avoid excessive impacts to aquatic or riparian vegetation and fish spawning or rearing habitat.
 - ┆ Minimize the effect of boat wakes on adjacent shoreline and reduce the potential for sediment accumulation on the ramp.
 - ┆ Minimize the required amount of cut and fill below the waterline in the submerged or submersible zone.
- Establish suitable ramp elevation and slope to minimize ramp size while providing a ramp that is usable throughout the normal range of water elevations.
 - ┆ Use average high- and low-water elevations for each month of the intended use period over a suitable period of record to determine design high-water and design low-water elevations.
 - ┆ Extend ramp toe to a sufficient depth below the design low-water elevation to provide adequate water depth to float the average boat from its trailer while providing a hard surface for the trailer to travel on during launch and retrieval.
 - ┆ Minimize the distance of the top of the ramp above the design high-water elevation consistent with local topography.
 - ┆ Design the launch ramp slope to minimize erosion from water and vehicle tire disturbance.

- Design ramp width to provide adequate space for boaters of varying ability to maneuver the boat trailers down the ramp.
- Use surfacing material suitable for the ramp location and character of use to provide sufficient traction to discourage wheel spin and damage to the ramp or surrounding soil and water resources.
- Use suitable measures along both sides and across the lower end of the launch ramp to protect the structure from externally generated forces such as current, waves, and boat wakes.
- Use applicable practices of BMP AqEco-2 (Operations in Aquatic Ecosystems) and BMP Fac-2 (Facility Construction and Stormwater Control) when constructing, reconstructing, or maintaining watercraft launch facilities.
- Use applicable practices of BMP Rec-2 (Developed Recreation Sites) when constructing and operating parking and staging areas at watercraft launch facilities.
- Use applicable practices of BMP Road-10 (Equipment Refueling and Servicing) at fuel dispensing facilities.
- Manage boating activities where necessary to decrease turbidity and physical destruction of shallow water habitats.
- Use applicable practices of BMP Fac-10 (Facility Site Reclamation) to reclaim watercraft launch sites when discontinuing their use.

Rec-9. Recreation Special Use Authorizations

Manual or Handbook

Reference FSM 2343, FSM 2721, and FSH 2709.11.

Objective Avoid, minimize, or mitigate adverse effects to soil, water quality, and riparian resources from physical, chemical, and biological pollutants resulting from activities under recreation special use authorizations.

Explanation This BMP covers all recreation special use activities with the exceptions of ski areas. BMP Rec-10 (Ski Runs and Lifts), BMP Rec-11 (Ski Area Snowmaking), and BMP Rec-12 (Ski Area Facilities) provide direction specific to ski areas.

The Forest Service role in defining and requiring the implementation of BMPs occurs during the development of the recreation special use authorization and administration of the use. Discussions between the Forest Service and the permit holder concerning soil, water quality, and riparian resource impacts and appropriate BMP use should occur at the time of permit development and renewal. The special use authorization details the conditions that must be met, including management requirements and mitigation measures to protect water quality. The permit holder will be required to conform to all applicable Federal, State, and local regulations governing water resource protection and sanitation. State water quality law may require that the permit holder obtain a pollution discharge permit, water quality certification, or other authorization from a State, regional, or local government entity.

Practices Develop site-specific BMP prescriptions for the following practices, as appropriate or when required, using State BMPs, Forest Service regional guidance, land management plan direction, BMP monitoring information, and professional judgment.

- Use applicable practices of BMP Fac-2 (Facility Construction and Stormwater Control) to provide erosion and stormwater controls when constructing facilities.

- ↳ Use applicable practices of BMP AqEco-2 (Operations in Aquatic Ecosystems) when working around waterbodies.
- Use applicable practices of Road Management Activities BMPs for access for authorized activities.
- Use applicable practices of Chemical Use Management Activities BMPs for use of chemicals in authorized activities.
- Use applicable practices of BMP Fac-3 (Potable Water Supply Systems), BMP Fac-4 (Sanitation Systems), BMP Fac-5 (Solid Waste Management), and BMP Fac-6 (Hazardous Materials) for public water supplies, sanitation systems, solid waste management, and hazardous materials for authorized activities.
- Administer the permit to appropriate standards to avoid, minimize, or mitigate adverse effects of permitted activities to soil, water quality, and riparian resources.

Rec-10. Ski Runs and Lifts

Manual or Handbook

Reference FSM 2342.1 and FSH 2709.11 41.6.

Objective Objective: Avoid, minimize, or mitigate adverse effects to soil, water quality, and riparian resources during the construction, operation, and maintenance of ski runs and lifts.

Explanation A ski area and its operation are complex and can result in a variety of adverse effects to soil, water quality, and riparian resources. These adverse effects can be particularly true for ski runs and lifts. Because good ski runs tend to be steep, extra precautions are needed to avoid or minimize accelerated erosion and resulting sedimentation. Ski run clearing, slope grading, and developing access routes, ski lift and towline facilities, and similar actions can expose and compact soils, resulting in accelerated runoff and erosion. Increased runoff can alter water yield and runoff regimes, augment peakflows, and increase instream sediment from channel erosion. Appropriate soil and water protection measures should be included in the ski area's operation and maintenance plan.

Practices Develop site-specific BMP prescriptions for the following practices, as appropriate or when required, using State BMPs, Forest Service regional guidance, land management plan direction, BMP monitoring information, and professional judgment.

- Locate ski runs and lifts on stable geology and soils to minimize risk of slope failures.
- Avoid wetlands and riparian areas when locating ski runs and lifts wherever practicable.
- Incorporate suitable measures in the design and construction of ski runs, including consideration of runoff of additional water from snowmaking, to avoid or minimize undesirable increases in runoff.
- Use applicable practices of Mechanical Vegetation Management Activities BMPs when clearing vegetation for ski runs and lift lines.
 - ↳ Use yarding equipment suitable to the steepness of the terrain to avoid or minimize adverse effects to soil and water quality (see BMP Veg-1 [Vegetation Management Planning]).
- Use applicable practices of BMP Veg-2 (Erosion Prevention and Control) to provide erosion and stormwater controls when constructing ski runs and lifts.
 - ↳ Clear and construct ski runs and lift lines in sections to limit the area of exposed disturbed soil at any one time.
 - ↳ Stabilize a completed section before beginning work on the next section.

-
- Avoid diverting streams and minimize disrupting swales, ephemeral channels, and wetlands.
 - Minimize grading or recontouring of hill slopes to maintain intact soil horizons and infiltrative properties.
 - Cut stumps flush with soil surface or grind in place instead of grubbing when clearing trees from ski runs wherever practicable.
 - Use applicable practices of BMP Road-7 (Stream Crossings) to design and construct stream crossings to minimize riparian and channel disturbance and pass anticipated flood flows and associated debris, while allowing desired aquatic organism passage.
 - ↳ Maintain normal stream patterns, geometry, and habitat features to the extent practicable.
 - Use low-pressure construction and maintenance equipment whenever practicable to reduce surface impact on steep slopes.
 - Stockpile biologically active topsoil removed during excavation for use in reclamation.
 - ↳ Store stockpiled topsoil separately from other vegetative slash, soil, or rock and protect from wind and water erosion, unnecessary compaction, and contaminants.
 - Use suitable species and establishment techniques to revegetate the site in compliance with local direction and requirements per FSM 2070 and FSM 2080 for vegetation ecology and prevention and control of invasive species.
 - Maintain desired ground cover with irrigation, fertilization, or other treatments as necessary.
 - Use suitable measures to direct overland flow on slopes into areas with intact soil horizons to encourage infiltration and disconnect overland flow from waterbodies.
 - Treat disturbed soil to promote onsite water capture and infiltration.
 - Prohibit traffic on disturbed areas during periods of excessive soil moisture, precipitation, or runoff.
 - Monitor revegetation response (height, root growth, ground coverage, etc.) in terms of its capacity to avoid or minimize erosion during runoff.
 - ↳ Perform additional revegetation or erosion control as needed to protect water quality and soil integrity.

Rec-11. Ski Area Snowmaking

Manual or Handbook

Reference FSM 2343.1 and FSH 2709.11 41.6.

Objective Avoid, minimize, or mitigate adverse effects to soil, water quality, and riparian resources at all stages of the snowmaking process, including diversions, conveyance, storage, application, and return of applied waters.

Explanation All phases of snowmaking at a ski area can affect the watershed and water quality. Construction of diversion, conveyance, storage, and delivery structures can create ground disturbance leading to erosion and sedimentation. Water withdrawal from rivers and streams can create or exacerbate stream dewatering and adversely affect overwintering habitat for fish and other aquatic-dependent species. Transfer of water from one basin to another for snowmaking can lead to an annual water supply outside the natural range of variation in the receiving watershed. This additional water in spring runoff can cause changes in stream channel morphology including streambank erosion and headward extension of the channel.

-
- Practices** Develop site-specific BMP prescriptions for the following practices, as appropriate or when required, using State BMPs, Forest Service regional guidance, land management plan direction, BMP monitoring information, and professional judgment.
- Manage snowmaking and snow farming to avoid or minimize slope failures and gully erosion on the hillslopes and excessive bank erosion and sediment in receiving streams.
 - ┆ Limit snowmaking on graded terrain to the extent practicable to minimize surface runoff and subsequent erosion from reduced infiltration capacity.
 - Use applicable practices of BMP WatUses-1 (Water Uses Planning) when authorizing snowmaking.
 - Use applicable practices of BMP AqEco-3 (Ponds and Wetlands), BMP WatUses-4 (Water Diversions and Conveyances), and BMP WatUses-5 (Dams and Impoundments) when obtaining water and developing water storage facilities for snowmaking.
 - Transport water to the slopes in the least disruptive manner.
 - ┆ Use applicable practices of BMP Fac-9 (Pipelines, Transmission Facilities, and Rights-of-Ways) when constructing, maintaining, and operating pipelines.
 - Design snowmaking systems to return runoff water to the source from which it was removed.
 - ┆ Avoid interbasin transfer of waters, where practicable, to maintain original duration, magnitude, and patterns of runoff in affected watersheds.
 - Avoid contaminating return water with chemicals or other pollutants.
 - Monitor all aspects of the process and correct problems as they occur to avoid or minimize long-term effects.
 - ┆ Regularly inspect snowmaking lines and equipment to prevent accidental discharges and erosion due to equipment failure.

Rec-12. Ski Area Facilities

Manual or Handbook

Reference FSM 2343.1 and FSH 2709.11 41.6.

Objective Avoid, minimize, or mitigate adverse effects to soil, water quality, and riparian resources originating from design, construction, operation, and maintenance of ski area facilities.

Explanation Ski area facilities include buildings, sanitary facilities, parking lots, and other infrastructure. These facilities can be located at the base of the ski area, mid-slope, or at the top of the ski hill. During construction and operation of facility sites, land may be cleared of existing vegetation and ground cover, exposing mineral soil that may be more easily eroded by water, wind, and gravity. Changes in land use and impervious surfaces can alter temporarily or permanently stormwater runoff that, if left uncontrolled, can affect morphology, stability, and quality of nearby streams and other waterbodies. Receiving waters can be contaminated by oil, grease, anti-freeze, sewage, trash, sediment, and salt. Construction and operation of these facilities should include measures that will avoid, minimize, or mitigate effects to water quality.

Practices Develop site-specific BMP prescriptions for the following practices, as appropriate or when required, using State BMPs, Forest Service regional guidance, land management plan direction, BMP monitoring information, and professional judgment.

- Locate ski area facilities on stable geology and soils to minimize risk of slope failures.
- Avoid wetlands and riparian areas to the extent practicable when locating ski area facilities.
- Use applicable practices of BMP Fac-2 (Facility Construction and Stormwater Control) to provide erosion and stormwater controls when constructing and operating ski area facilities.
- Use applicable practices of BMP Road-2 (Road Location and Design), BMP Road-3 (Road Construction and Reconstruction), BMP Road-4 (Road Operations and Maintenance), BMP Road-8 (Snow Storage and Removal), and BMP Road-9 (Parking Sites and Staging Areas) for designing, constructing, maintaining, and operating roads and parking areas at ski area facilities.
- Use applicable practices of BMP Fac-9 (Pipelines, Transmission Facilities, and Rights-of-Way) for managing power and utility lines at the ski area facilities.
- Use applicable practices of BMP Fac-6 (Hazardous Materials), BMP Fac-7 (Vehicle and Equipment Wash Water), and BMP Road-10 (Equipment Refueling and Servicing) for activities related to storage and maintenance of ski area vehicles and equipment.
- Use applicable practices of BMP Fac-3 (Potable Water Supply Systems) for drinking water, BMP Fac-4 (Sanitation Systems) for managing human waste, and BMP Fac-5 (Solid Waste Management) for managing solid waste at ski area facilities.
- Use applicable practices of BMP Fac-10 (Facility Site Reclamation) when discontinuing use at ski area facilities.

Resources for Recreation Management Activities

Marinas and Recreational Boating

Oregon State Marina Board. 2002. Best management practices for environmental and habitat protection in design and construction of recreational boating facilities. Oregon State Marina Board. 9 p. Available at <http://www.boatoregon.com/OSMB/library/docs/BoatingFacBMP2002-1.pdf>.

U.S. Environmental Protection Agency (EPA), Office of Water. 2005. National management measures to control nonpoint source pollution from marinas and recreational boating. EPA-841-B-05-003. Washington, DC: U.S. Environmental Protection Agency, Office of Water. Available at <http://www.epa.gov/owow/NPS/mmsp/index.html>.

Off-Highway Vehicles

McCullah, J.; Sloan, R.; Dettman, K.; Jacobson, N.; and others. 2007. OHV BMP manual for erosion and sediment control. Sacramento, CA: State of California, Department of Parks and Recreation, Off-Highway Motor Vehicle Recreation Division. 317 p. Available at <http://www.watchyourdirt.com/erosion-control-files/>.

Shooting Ranges

EPA. 2005. Best management practices for lead at outdoor shooting ranges. EPA 902-B-01-001. New York, NY. Available at http://www.epa.gov/region02/waste/leadshot/epa_bmp.pdf.

Site Restoration

Therrell, L.; Cole, D.; Claassen, V.; Ryan, C.; Davies, M.A. 2006. Wilderness and backcountry site restoration guide. 0623-2815-MTDC. Missoula, MT: U.S. Department of Agriculture (USDA), Forest Service, Technology and Development Program. 394 p. Available at <http://www.treesearch.fs.fed.us/pubs/26795>.

Ski Areas

USDA Forest Service. 2000. Ski area BMPs—(Best management practices) guidelines for planning, erosion control, and reclamation. Salt Lake City, UT: U.S. Department of Agriculture, Forest Service, Wasatch-Cache National Forest, in cooperation with Sun Valley Corporation and Snowbasin Ski Area. 28 p.

Trails Davies, M.A.; Outka-Perkins, L. 2006. Building mountain bike trails: Sustainable singletrack. 0623-2314-MTDC (DVD). Missoula, MT: USDA Forest Service, Technology and Development Program. Available at <http://fsweb.mtdc.wo.fs.fed.us/pubs/htmlpubs/htm06232341/index.htm>.

Hesselbarth, W.; Vachowski, B.; Davies, M.A. 2007. Trail construction and maintenance notebook. 0723-2806-MTDC. Missoula, MT: U.S. Department of Agriculture, Forest Service, Technology and Development Program. 178 p. Available at <http://fsweb.mtdc.wo.fs.fed.us/pubs/htmlpubs/htm07232806/>.

State of New Hampshire, Department of Resources and Economic Development. 2004. Best management practices for erosion control during trail maintenance and construction. Concord, NH: State of New Hampshire, Department of Resources and Economic Development, Division of Parks and Recreation, Bureau of Trails. 27 p. Available at <http://atfiles.org/files/pdf/BMPmanual2004.pdf>.

Steinholz, R.T.; Vachowski, B. 2007. Wetland trail design and construction. 0723-2804-MTDC. Missoula, MT: USDA Forest Service, Technology and Development Program. 90 p. Available at <http://fsweb.mtdc.wo.fs.fed.us/pubs/htmlpubs/htm07232804/index.htm>

Road Management Activities

The purpose of this set of Best Management Practices (BMPs) is to avoid, minimize, or mitigate adverse effects to soil, water quality, and instream riparian resources that may result from road management activities. Road management activities include travel route planning, design, construction, operation, maintenance, reconstruction, storage, and decommissioning. Other transportation-system-related activities include stream and waterbody crossings, snow removal, parking areas, and equipment refueling and servicing areas.

Eleven National Core BMPs are in the Road Management Activities Category. These BMPs are to be used when managing roads on National Forest System (NFS) lands. BMP Road-1 (Travel Management Planning and Analysis) is a planning BMP for transportation systems. BMP Road-2 (Road Location and Design), BMP Road-3 (Road Construction and Reconstruction), and BMP Road-4 (Road Operations and Maintenance) provide project-level direction for road construction and operations. BMP Road-5 (Temporary Roads) provides direction for construction and use of temporary roads. BMP Road-6 (Road Storage and Decommissioning) provides direction for roads that will not be needed for 1 year or more, or that are no longer needed. BMP Road-7 (Stream Crossings) provides practices for fords, bridges, culverts, and other crossings of flowing or standing water. BMP Road-8 (Snow Removal and Storage) provides direction for snowplowing. BMP Road-9 (Parking Areas and Staging Areas) provides direction for constructing and operating permanent and temporary parking areas. BMP Road-10 (Equipment Refueling and Servicing) provides practices for vehicle refueling and servicing areas. BMP Road-11 (Road Storm-Damage Surveys) provides direction for monitoring of roads after major storms. Each BMP draws on administrative directives that guide agency management of roads on NFS land (Forest Service Manual [FSM] 7710).

States will be used in the rest of this resource category to signify both States and those tribes that have received approval from the U.S. Environmental Protection Agency (EPA) for treatment as a State under the Clean Water Act (CWA).

Road BMPs	
Road-1	Travel Management Planning and Analysis
Road-2	Road Location and Design
Road-3	Road Construction and Reconstruction
Road-4	Road Operations and Maintenance
Road-5	Temporary Roads
Road-6	Road Storage and Decommissioning
Road-7	Stream Crossings
Road-8	Snow Removal and Storage
Road-9	Parking and Staging Areas
Road-10	Equipment Refueling and Servicing
Road-11	Road Storm-Damage Surveys

Road-1. Travel Management Planning and Analysis

Manual or Handbook

Reference Forest Service Manual (FSM) 7710; Forest Service Handbook (FSH) 7709.55; and FSH 7709.59, chapter 10.

Objective Use the travel management planning and analysis processes to develop measures to avoid, minimize, or mitigate adverse effects to soil, water quality, and riparian resources during road management activities.

Explanation Road management related planning includes travel analyses as well as consideration of road management objectives and maintenance levels to address access needs and adjustments for projects. Planning occurs at scales that range from forestwide assessments and plans, to watershed scale or project-level analyses, to individual road activities. Effects to soil, water quality, and riparian resources are evaluated during planning and balanced with the social, economic, and land management needs of the area. Appropriate protection and mitigation measures are considered when soil, water quality, and riparian resources may be adversely impacted.

Travel analysis is conducted at a scope and scale determined by the line officer and used to inform future project decisions on the benefits and risks of, as well as the ongoing need for, the transportation system. Project-level travel analyses are conducted to inform decisions and facilitate vegetation, fire and fuels, rangeland, recreation, minerals, or other management actions. Such analyses contain detail on the condition of individual roads. Options for road management are shown in figure 3.

Road Management Objectives (RMOs) are developed and documented for each system road and include the intent and purpose in providing access to implement the land management plan. In addition to considering route needs at the site scale, RMOs also document the purpose of the road (access needs) along with operational maintenance levels and objectives.

Practices Develop site-specific BMP prescriptions for the following practices, as appropriate or when required, using State BMPs, Forest Service regional guidance, land management plan direction, BMP monitoring information, and professional judgment.

- Use applicable practices of BMP Plan-2 (Project Planning and Analysis) and BMP Plan-3 (Aquatic Management Zone [AMZ] Planning) when conducting travel management planning and analysis.
- Use interdisciplinary coordination for travel planning and project-level transportation analysis, including engineers, hydrologists, soil scientists, and other resource specialists as needed, to balance protection of soil, water quality, and riparian resources with transportation and access needs.
- Design the transportation system to meet long-term land management plan desired conditions, goals, and objectives for access rather than to access individual sites.
- Limit roads to the minimum practicable number, width, and total length consistent with the purpose of specific operations, local topography, geology, and climate to achieve land management plan desired conditions, goals, and objectives for access and water quality management.
 - ┆ Use existing roads when practicable.
 - ┆ Use system roads where access is needed for long-term management of an area or where control is needed in the location, design, or construction of the road to avoid, minimize, or mitigate adverse effects to soil, water quality, and riparian resources.

Figure 3. Road Options

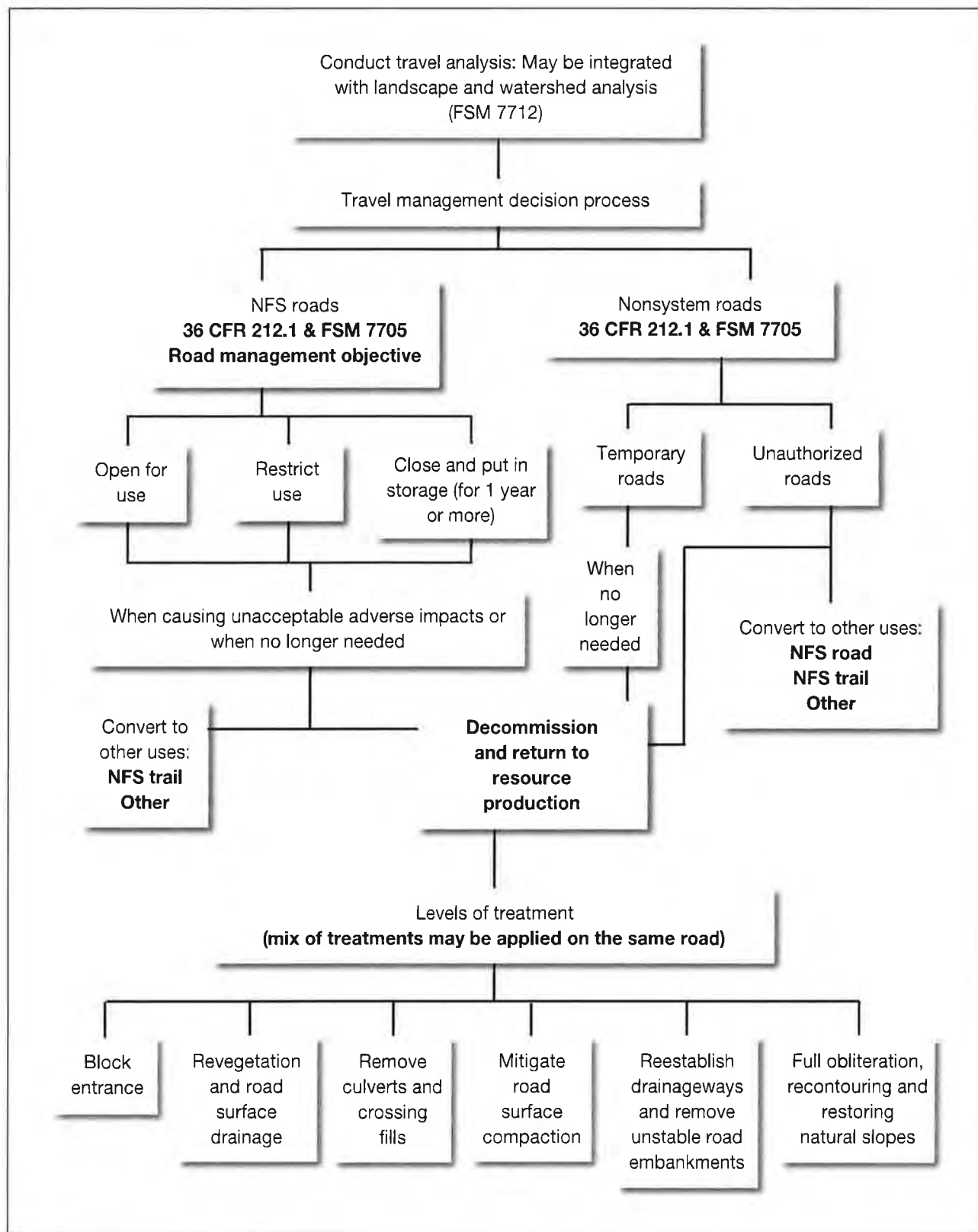

-
- ↳ Use temporary roads for short-term access needs if the road can be constructed, operated, and obliterated without specific control of techniques to avoid, minimize, or mitigate adverse effects to soil, water quality, and riparian resources (See BMP Road-5 [Temporary Roads]).
 - ↳ Decommission temporary roads and return to resource production when the access is no longer needed (See BMP Road-6 [Road Storage and Decommissioning]).
 - ↳ Consider placing roads in storage (Maintenance Level 1) when the time between intermittent uses exceeds 1 year and the costs of annual maintenance (both economic and potential disturbance) or potential failures due to lack of maintenance exceed the benefits of keeping the road open in the interim (See BMP Road-6 [Road Storage and Decommissioning]).
 - ↳ Consider decommissioning unneeded existing roads within a planning area when planning new system roads to reduce cumulative impacts to soil, water quality, and riparian resources (See BMP Road-6 [Road Storage and Decommissioning]).
 - Plan road networks to have the minimum number of waterbody crossings as is practicable and necessary to achieve transportation system desired conditions, goals, and objectives.
 - Develop or update RMOs for each system road to include design criteria, operation criteria, and maintenance criteria to avoid, minimize, or mitigate adverse effects to soil, water quality, and riparian resources.
 - ↳ Use applicable practices of BMP Road-2 (Road Location and Design) to establish design elements and standards.
 - ↳ Use applicable practices of BMP Road-4 (Road Operations and Maintenance) to establish criteria on how the road is to be operated and maintained.
 - ↳ Revise RMOs as needed to meet changing conditions.
 - Identify and evaluate road segments causing, or with the potential to cause, adverse effects to soil, water quality, and riparian resources.
 - ↳ Identify and prioritize suitable mitigation measures to avoid, minimize, or mitigate adverse effects (see BMPs Road-2 (Road Location and Design), Road-3 (Road Construction and Reconstruction), Road-4 (Road Operations and Maintenance), Road-6 (Road Storage and Decommissioning), and Road-7 (Stream Crossings) for potential mitigation measures).

Road-2. Road Location and Design

Manual or Handbook

Reference FSM 7720 and FSH 7709.56.

Objective Locate and design roads to avoid, minimize, or mitigate adverse effects to soil, water quality, and riparian resources.

Explanation Roads are located according to standards and specifications to meet their use objectives while protecting other resources. Well-defined project objectives are needed to locate and design roads that will best address environmental and resources issues as well as road use, safety, and traffic requirements.

New roads can be designed to avoid or minimize adverse effects to soil, water quality, and riparian resources, while existing roads may need to be redesigned or relocated to mitigate such effects. Management needs have changed considerably since most NFS roads were constructed. Influences of roads on aquatic and riparian systems are currently better understood. Designs for improvements

to existing roads often revise the original design to change location, drainage, crossing type or size, or surfacing. Improvements to the road system are made on a priority basis that considers road and resource condition, values at risk, available funding, and cost.

In addition, some situations may require adherence to special conditions associated with Clean Water Act (CWA) 401 certification, CWA 402 permits, and CWA 404 permits. State and local entities may also provide guidance and regulations such as a Forest Practices Act or a Stream Alteration Act. Land management plans often contain direction on location of roads relative to streams, wetlands, and unstable landforms.

Practices Develop site-specific BMP prescriptions for the following practices, as appropriate or when required, using State BMPs, Forest Service regional guidance, land management plan direction, BMP monitoring information, and professional judgment.

Location

- Locate roads to fit the terrain, follow natural contours, and limit the need for excavation.
 - ↳ Avoid locations that require extended steep grades, sharp curves, or switchbacks.
- Locate roads on stable geology with well-drained soils and rock formations that dip into the slope.
 - ↳ Avoid hydric soils, inner gorges, overly steep slopes, and unstable landforms to the extent practicable.
- Locate roads as far from waterbodies as is practicable to achieve access objectives, with a minimum number of crossings and connections between the road and the waterbody.
 - ↳ Avoid sensitive areas such as riparian areas, wetlands, meadows, bogs, and fens, to the extent practicable.
 - ↳ Provide an AMZ of suitable width between the road and a waterbody to maintain desired conditions, goals, and objectives for structure, function, and processes of the AMZ and associated waterbody when a road must parallel a waterbody (See BMP Plan-3 [AMZ Planning]).
- Relocate existing routes or segments that are causing, or have the potential to cause, adverse effects to soil, water quality, and riparian resources, to the extent practicable.
 - ↳ Obliterate the existing road or segment after the relocated section is completed (see BMP Road-6 [Road Storage and Decommissioning]).

Predesign

- Consider design criteria relative to soil, water quality, and riparian resources from the decision document and associated National Environmental Policy Act (NEPA) analysis document.
- Consider the road RMOs and likely future maintenance schedule in the initial design.
- Conduct suitable site investigations, data collection, and evaluations commensurate with the anticipated design and sensitivity of the area to soil, water quality, and riparian resource impacts.
 - ↳ Consider subsurface conditions and conduct suitable investigations and stability analyses for road and bridge locations where slope instability can occur due to road construction.
 - ↳ Conduct a suitable soils and geotechnical evaluation to identify susceptibility to erosion and stable angles of repose.

Design

- Design the road to fit the ground and terrain with the least practicable impacts to soil, water quality, and riparian resources considering the purpose and life of the road, safety, and cost.
 - ↳ Use road standards that minimize impacts for grade and alignment (e.g., width, turning radius, and maximum slope).
 - ↳ Use low impact development treatments that reduce long-term maintenance needs wherever practicable.
- Design the road to maintain stable road prism, cut, and fill slopes.
 - ↳ Design cut and fill slope ratios to reduce soil loss from mass failures.
 - ↳ Use structural or nonstructural measures as necessary to stabilize cut and fill slopes.
- Design the road surface drainage system to intercept, collect, and remove water from the road surface and surrounding slopes in a manner that minimizes concentrated flow in ditches, culverts, and over fill slopes and road surfaces.
 - ↳ Use structural or nonstructural measures suitable to the road materials, road gradient, and expected traffic levels.
 - ↳ Use an interval between drainage features that is suitable for the road gradient, surface material, and climate.
 - ↳ Use suitable measures to avoid or minimize erosion of ditches.
- Design the road subsurface drainage system to intercept, collect, and remove groundwater that may flow into the base course and subgrade, lower high-water tables, and drain water pockets.
 - ↳ Use suitable subsurface dispersion or collection measures to capture and disperse locally shallow groundwater flows intercepted by road cuts.
 - ↳ Use suitable measures to release groundwater into suitable areas without causing erosion or siltation.
- Design the road for minimal disruption of natural drainage patterns and to minimize the hydrologic connection of the road segment or network with nearby waterbodies.
 - ↳ Use suitable structural or nonstructural measures to avoid or minimize gully formation and erosion of fill slopes at outfalls of road surface drainage structures.
 - ↳ Use suitable measures to avoid, to the extent practicable, or minimize direct discharges from road drainage structures to nearby waterbodies.
 - ↳ Provide sufficient buffer distance at the outfalls of road surface drainage structures for water to infiltrate before reaching the waterbody.
 - ↳ Use applicable practices of BMP Road-7 (Stream Crossings) to limit the number and length of water crossing connected areas to the extent practicable.
- Design road surface treatment to support wheel loads, stabilize the roadbed, reduce dust, and control erosion consistent with anticipated traffic and use.
 - ↳ Consider whether road closures or roadway surface drainage and erosion protection can adequately mitigate adverse effects to soil, water quality, and riparian resources.
- Design roads within the AMZ (when no practicable alternative exists outside of the AMZ to achieve access objectives) to maintain desired conditions, goals, and objectives for AMZ structure, function, and processes (See BMP Plan-3 [AMZ Planning]).

- ┆ Use suitable measures to minimize or mitigate effects to waterbodies and other sensitive areas when adverse impacts cannot be practicably avoided.
- Design waterbody crossings to avoid or minimize adverse effects to soil, water quality, and riparian resources to the extent practicable consistent with road use, legal requirements, and cost considerations (See BMP Road-7 [Stream Crossings]).
- Design a post-construction site vegetation plan, including short- and long-term objectives, using suitable species and establishment techniques to revegetate the site in compliance with local direction and requirements per FSM 2070 and FSM 2080 for vegetation ecology and prevention and control of invasive species.

Road-3. Road Construction and Reconstruction

Manual or Handbook

Reference FSM 7720, FSH 7709.56, and FSH 7709.57.

Objective Avoid or minimize adverse effects to soil, water quality, and riparian resources from erosion, sediment, and other pollutant delivery during road construction or reconstruction.

Explanation During road construction and reconstruction activities, vegetation and ground cover is removed exposing soil to erosion. Temporary and long-term erosion control and stormwater management measures are necessary to reduce erosion and maintain overall slope stability. These erosion control measures may include vegetative and structural practices to ensure long-term stability of the area.

Practices Develop site-specific BMP prescriptions for the following practices, as appropriate or when required, using State BMPs, Forest Service regional guidance, land management plan direction, BMP monitoring information, and professional judgment.

- Use applicable practices of BMP Fac-2 (Facility Construction and Stormwater Control) for stormwater management and erosion control when constructing or reconstructing system roads.
- Use suitable construction techniques to create stable fills.
 - ┆ Use full bench construction techniques or retaining walls where stable fill construction is not possible.
 - ┆ Avoid incorporating woody debris in the fill portion of the road prism.
 - ┆ Leave existing rooted trees or shrubs at the toe of the fill slope to stabilize the fill.
 - ┆ Avoid use of road fills for water impoundment dams unless specifically designed for that purpose.
- Identify and locate waste areas before the start of operations.
 - ┆ Deposit and stabilize excess and unsuitable materials only in designated sites.
 - ┆ Do not place such materials on slopes with a risk of excessive erosion, sediment delivery to waterbodies, mass failure, or within the AMZ.
 - ┆ Provide adequate surface drainage and erosion protection at disposal sites.
- Do not permit sidecasting within the AMZ.
 - ┆ Avoid or minimize excavated materials from entering waterbodies or AMZs.
- Develop and follow blasting plans when necessary.
 - ┆ Use restrictive blasting techniques in sensitive areas and in sites that have high landslide potential.

- ↳ Avoid blasting when soils are saturated.
- Remove slash and cull logs to designated sites outside the AMZ for storage or disposal.
 - ↳ Consider using cull logs in aquatic ecosystem projects to achieve aquatic resource management objectives as opportunities arise.
- Use suitable measures in compliance with local direction to prevent and control invasive species.
- Construct pioneer roads using suitable measures to avoid, minimize, or mitigate adverse effects to soil, water quality, and riparian resources.
 - ↳ Confine construction of pioneer roads to the planned roadway limits unless otherwise specified.
 - ↳ Locate and construct pioneering roads to avoid or minimize undercutting of the designated final cut slope.
 - ↳ Avoid deposition of materials outside the designated roadway limits.
 - ↳ Use suitable crossing structures, or temporarily dewater live streams, where pioneer roads intersect streams.
 - ↳ Use suitable erosion and stormwater control measures as needed (see BMP Fac-2 [Facility Construction and Stormwater Control]).
- Reconstruct existing roads to the degree necessary to provide adequate drainage and safety.
 - ↳ Avoid disturbing stable road surfaces.
 - ↳ Use suitable measures to avoid, to the extent practicable, or minimize direct discharges from road drainage structures to nearby waterbodies.

Road-4. Road Operations and Maintenance

Manual or Handbook

Reference FSM 7732 and FSH 7709.59, chapter 60.

Objective Avoid, minimize, or mitigate adverse effects to soil, water quality, and riparian resources by controlling road use and operations and providing adequate and appropriate maintenance to minimize sediment production and other pollutants during the useful life of the road.

Explanation Control of road use and operations and appropriate maintenance can protect road investment and soil, water quality, and riparian resources. Periodic inventory and assessment that determine road condition are used to determine operational controls and maintenance needs.

Operational objectives and activities are documented in the RMOs. In travel management decisions, roads open to motorized vehicle use are designated by allowed vehicle class and, if appropriate, by time of year. Road operations include administering permits, contracts, and agreements, controlling allowed use, maintaining roads in closed status, and revising maintenance levels and seasonal closures as needed. Road closures and restrictions are necessary because many forest roads are designed for dry season use. Many local roads are not surfaced; while others have some surfacing but little to no base. Such roads can be damaged by use during wet periods or by loads heavier than the road was designed to convey.

Properly maintained road surfaces and drainage systems can reduce adverse effects to water resources by encouraging natural hydrologic function. Roads and drainage systems normally deteriorate because of traffic, weather, and age. In addition, roads occasionally become saturated

by groundwater springs and seeps after a wildfire or unusually wet periods. Many such conditions can be corrected by timely maintenance. While routine maintenance is needed to ensure the road performs as designed, however, it can also be a source of soil disturbance, concentrated flow, sediment production, and slope instability if done improperly. Lower impact maintenance techniques may be desired to minimize disturbance of stable sites.

Practices Develop site-specific BMP prescriptions for the following practices, as appropriate or when required, using State BMPs, Forest Service regional guidance, land management plan direction, BMP monitoring information, and professional judgment.

Operations

- Designate season of use to avoid or restrict road use during periods when use would likely damage the roadway surface or road drainage features.
- Designate class of vehicle and type of uses suitable for the road width, location, waterbody crossings, and road surfaces to avoid or minimize adverse effects to soil, water quality, or riparian resources to the extent practicable.
- Use suitable measures to communicate and enforce road use restrictions.
- Use suitable measures to avoid or minimize adverse effects to soil, water quality, or riparian resources when proposed operations involve use of roads by traffic and during periods for which the road was not designed.
 - ┆ Strengthen the road surface in areas where surfaces are vulnerable to movement such as corners and steep sections.
 - ┆ Upgrade drainage structures to avoid, to the extent practicable, or minimize direct discharges into nearby waterbodies.
 - ┆ Restrict use to low-ground-pressure vehicles or frozen ground conditions.
 - ┆ Strengthen the road base if roads are tending to rut.
 - ┆ Adjust maintenance to handle the traffic while minimizing excessive erosion and damage to the road surface.
- Ensure that drainage features are fully functional on completion of seasonal operations.
 - ┆ Shape road surfaces to drain as designed.
 - ┆ Construct or reconstruct drainage control structures as needed.
 - ┆ Ensure that ditches and culverts are clean and functioning.
 - ┆ Remove berms unless specifically designed for erosion control purposes.
- Consider potential for water quality effects from road damage when granting permits for over-size or overweight loads.
- Use suitable road surface stabilization practices and dust abatement supplements on roads with high or heavy traffic use (See FSH 7709.56 and FSH 7709.59).
- Use applicable practices of Chemical Use Management Activities BMPs when chemicals are used in road operations.

Inspection

- Periodically inspect system travel routes to evaluate condition and assist in setting maintenance and improvement priorities.

-
- ┆ Give inspection priority to roads at high risk of failure to reduce risk of diversions and cascading failures.
 - Inspect drainage structures and road surfaces after major storm events and perform any necessary maintenance (see BMP Road-11 [Road Storm-Damage Surveys]).
 - ┆ Repair and temporarily stabilize road failures actively producing and transporting sediment as soon as practicable and safe to do so.
 - Inspect roads frequently during all operations.
 - ┆ Restrict use if road damage such as unacceptable surface displacement or rutting is occurring.

Maintenance Planning

- Develop and implement annual maintenance plans that prioritize road maintenance work for the forest or district.
 - ┆ Increase priority for road maintenance work on road sections where road damage is causing, or potentially would cause, adverse effects to soil, water quality, and riparian resources.
 - ┆ Consider the risk and consequence of future failure at the site when prioritizing repair of road failures.
- Develop and implement annual road maintenance plans for projects where contractors or permittees are responsible for maintenance activities.
 - ┆ Define responsibilities and maintenance timing in the plan.

Maintenance Activities

- Maintain the road surface drainage system to intercept, collect, and remove water from the road surface and surrounding slopes in a manner that reduces concentrated flow in ditches, culverts, and over fill slopes and road surfaces.
 - ┆ Clean ditches and catch basins only as needed to keep them functioning.
 - ┆ Do not undercut the toe of the cut slope when cleaning ditches or catch basins.
 - ┆ Use suitable measures to avoid, to the extent practicable, or minimize direct discharges from road drainage structures to nearby waterbodies.
- Identify diversion potential on roads and prioritize for treatment.
 - ┆ Minimize diversion potential through installation and maintenance of dips, drains, or other suitable measures.
- Maintain road surface treatments to stabilize the roadbed, reduce dust, and control erosion consistent with anticipated traffic and use.
- Grade road surfaces only as necessary to meet the smoothness requirements of the assigned operational maintenance level and to provide adequate surface drainage.
 - ┆ Do not undercut the toe of the cut slope when grading roads.
 - ┆ Do not permit sidecasting of maintenance-generated debris within the AMZ to avoid or minimize excavated materials entering waterbodies or riparian areas.
 - ┆ Avoid overwidening of roads due to repeated grading over time, especially where sidecast material would encroach on waterbodies.
 - ┆ Use potential sidecast or other waste materials on the road surface where practicable.
 - ┆ Dispose of unusable waste materials in designated disposal sites.

-
- Remove vegetation from swales, ditches, and shoulders, and cut and fill slopes only when it impedes adequate drainage, vehicle passage, or obstructs necessary sight distance to avoid or minimize unnecessary or excessive vegetation disturbance.
 - Maintain permanent stream crossings and associated fills and approaches to reduce the likelihood that water would be diverted onto the road or erode the fill if the structure becomes obstructed.
 - Identify waterbody-crossing structures that lack sufficient capacity to pass expected flows, bedload, or debris, or that do not allow for desired aquatic organism passage, and prioritize for treatment.
 - ↳ Use applicable practices of BMP Road-7 (Stream Crossings) to improve crossings.
 - Use applicable practices of BMP Road-6 (Road Storage and Decommissioning) for maintenance and management of Maintenance Level 1 roads.
 - Ensure the necessary specifications concerning prehaul maintenance, maintenance during haul, and posthaul maintenance (putting the road back in storage) are in place when maintenance level 1 roads are opened for use on commercial resource management projects or other permitted activities.
 - ↳ Require the commercial operator or responsible party to leave roads in a satisfactory condition when project is completed.

Road-5. Temporary Roads

Manual or Handbook

Reference None known.

Objective Avoid, minimize, or mitigate adverse effects to soil, water quality, and riparian resources from the construction and use of temporary roads.

Explanation Temporary roads may be used in situations where access needs are short-term and the roads can be constructed without requiring advanced engineering design or construction practices to avoid, minimize, or mitigate adverse effects to resources. Practices related to road location and stormwater and erosion control should be applied to temporary roads. Temporary roads are to be decommissioned and the area returned to resource production after the access is no longer needed.

Practices Develop site-specific BMP prescriptions for the following practices, as appropriate or when required, using State BMPs, Forest Service regional guidance, land management plan direction, BMP monitoring information, and professional judgment.

- Use applicable practices of BMP Road-2 (Road Location and Design) to locate temporary roads.
- Use applicable practices of BMP Fac-2 (Facility Construction and Stormwater Control) for stormwater management and erosion control when constructing temporary roads.
- Install sediment and stormwater controls before initiating surface-disturbing activities to the extent practicable.
- Schedule construction activities to avoid direct soil and water-disturbance during periods of the year when heavy precipitation and runoff are likely to occur.
- Routinely inspect temporary roads to verify that erosion and stormwater controls are implemented, functioning, and appropriately maintained.

- Maintain erosion and stormwater controls as necessary to ensure proper and effective functioning.
- Use suitable measures in compliance with local direction to prevent and control invasive species.
- Use temporary crossings suitable for the expected uses and timing of use (See BMP Road-7 [Stream Crossings]).
- Use applicable practices of BMP Road-6 (Road Storage and Decommissioning) to obliterate the temporary road and return the area to resource production after the access is no longer needed.

Road-6. Road Storage and Decommissioning

Manual or Handbook

Reference FSH 7709.59, chapter 60 and FSM 7734.

Objective Avoid, minimize, or mitigate adverse effects to soil, water quality, and riparian resources by storing closed roads not needed for at least 1 year (Intermittent Stored Service) and decommissioning unneeded roads in a hydrologically stable manner to eliminate hydrologic connectivity, restore natural flow patterns, and minimize soil erosion.

Explanation Roads not needed for access for long periods (greater than 1 year) may be put into storage (Intermittent Stored Service—Maintenance Level 1) to reduce maintenance costs. Level 1 roads receive basic custodial maintenance focusing on maintaining drainage facilities and runoff patterns to avoid or minimize damage to adjacent resources and to perpetuate the road for future use. The integrity of the roadway is retained to the extent practicable and measures are implemented to reduce sediment delivery from the road surface and fills and reduce the risk of crossing failure and stream diversion.

Roads no longer needed are identified during transportation planning activities at the forest, watershed, or project level. The former road may be decommissioned or converted to a trail as appropriate. Decommissioned roads are stabilized and restored to a more natural state to protect and enhance NFS lands. Temporary roads constructed for a specific short-term purpose (e.g., ski area development, minerals exploration, or timber harvesting) are decommissioned at the completion of their intended use.

Road decommissioning includes a variety of treatments to block the road, revegetate the road surface, restore surface drainage, remove crossing structures and fills, mitigate road surface compaction, re-establish drainageways, remove unstable road embankments, and recontour the surface to restore natural slopes. One or more treatments are applied to decommission the road depending on resource objectives and cost.

Practices Develop site-specific BMP prescriptions for the following practices, as appropriate or when required, using State BMPs, Forest Service regional guidance, land management plan direction, BMP monitoring information, and professional judgment.

All Activities

- Implement suitable measures to close and physically block the road entrance so that unauthorized motorized vehicles cannot access the road.
 - Remove the road from the Motor Vehicle Use Map (MVUM) to include the change in the annual forestwide order associated with the MVUM.
- Establish effective ground cover on disturbed sites to avoid or minimize accelerated erosion and soil loss.

-
- ┆ Use suitable species and establishment techniques to stabilize and revegetate the site in compliance with local direction and requirements per FSM 2070 and FSM 2080 for vegetation ecology and prevention and control of invasive species.

Road Storage

- Evaluate all stream and waterbody crossings for potential for failure or diversion of flow if left without treatment.
 - ┆ Use suitable measures to reduce the risk of flow diversion onto the road surface.
 - ┆ Consider leaving existing crossings in low-risk situations where the culvert is not undersized, does not present an undesired passage barrier to aquatic organisms, and is relatively stable.
 - ┆ Remove culverts, fill material, and other structures that present an unacceptable risk of failure or diversion.
 - ┆ Reshape the channel and streambanks at the crossing-site to pass expected flows without scouring or ponding, minimize potential for undercutting or slumping of streambanks, and maintain continuation of channel dimensions and longitudinal profile through the crossing site.
 - ┆ Use suitable measures to avoid or minimize scour and downcutting.
- Use suitable measures to ensure that the road surface drainage system will intercept, collect, and remove water from the road surface and surrounding slopes in a manner that reduces concentrated flow in ditches, culverts, and over fill slopes and road surfaces without frequent maintenance.
- Use suitable measures to stabilize unstable road segments, seeps, slumps, or cut or fill slopes where evidence of potential failure exists.

Road Conversion to Trail

- Reclaim unneeded road width, cut, and fill slopes when converting a road for future use as a trail.
- Use suitable measures to stabilize reclaimed sections to avoid or minimize undesired access and to restore desired ecologic structures or functions.
- Use suitable measures to ensure that surface drainage will intercept, collect, and remove water from the trail surface and surrounding slopes in a manner that minimizes concentrated flow and erosion on the trail surfaces without frequent maintenance.
- Use applicable practices of BMP Road-7 (Stream Crossings) to provide waterbody crossings suitable to the expected trail uses.

Road Decommissioning

- Use existing roads identified for decommissioning as skid roads in timber sales or land stewardship projects before closing the road, where practicable, as the opportunity arises.
- Evaluate risks to soil, water quality, and riparian resources and use the most practicable, cost-effective treatments to achieve long-term desired conditions and water quality management goals and objectives.
- Use applicable practices of BMP Fac-2 (Facility Construction and Stormwater Control) for stormwater management and erosion control when obliterating system roads.
- Implement suitable measures to re-establish stable slope contours and surface and subsurface hydrologic pathways where necessary to the extent practicable to avoid or minimize adverse effects to soil, water quality, and riparian resources.
 - ┆ Remove drainage structures.

- ↳ Recontour and stabilize cut slopes and fill material.
- ↳ Reshape the channel and streambanks at crossing sites to pass expected flows without scouring or ponding, minimize potential for undercutting or slumping of streambanks, and maintain continuation of channel dimensions and longitudinal profile through the crossing site.
- ↳ Restore or replace streambed materials to a particle size distribution suitable for the site.
- ↳ Restore floodplain function.
- Implement suitable measures to promote infiltration of runoff and intercepted flow and desired vegetation growth on the road prism and other compacted areas.
- Use suitable measures in compliance with local direction to prevent and control invasive species.

Road-7. Stream Crossings

Manual or Handbook

Reference Manual or Handbook Reference: FSM 7722 and FSH 7709.56b.

Objective Avoid, minimize, or mitigate adverse effects to soil, water quality, and riparian resources when constructing, reconstructing, or maintaining temporary and permanent waterbody crossings.

Explanation Forest and grassland management activities often occur in areas that require surface waters to be crossed. Depending on the activity type and duration, crossings may be needed permanently or temporarily. Permanent crossings, in general, are more durable and are designed by an engineer to meet applicable standards while also protecting water quality and riparian resources.

Examples of crossings include culverts, bridges, arched pipes, low-water crossings, vented fords, and permeable fills. Crossing materials and construction will vary based on the type of access required, duration of need, and volume of use expected. Crossings should be designed and installed to provide for flow of water, bedload, and large woody debris, desired aquatic organism passage, and to minimize disturbance to the surface and shallow groundwater resources.

Construction, reconstruction, and maintenance of a crossing usually requires heavy equipment to be in and near streams, lakes, and other aquatic habitats to install or remove culverts, fords, and bridges, and their associated fills, abutments, piles, and cribbing. Such disturbance near the waterbody can increase the potential for accelerated erosion and sedimentation by altering flow paths and destabilizing streambanks or shorelines, removing vegetation and ground cover, and exposing or compacting the soil. Use of heavy equipment has a potential for contaminating the surface water from vehicle fluids or introducing aquatic nuisance species.

Some crossings may require adherence to special conditions associated with CWA 401 certification or CWA 404 permits. State and local entities may also provide guidance and regulations such as a Forest Practices Act or a Stream Alteration Act.

Practices Develop site-specific BMP prescriptions for the following practices, as appropriate or when required, using State BMPs, Forest Service regional guidance, land management plan direction, BMP monitoring information, and professional judgment.

All Crossings

- Plan and locate surface water crossings to limit the number and extent to those that are necessary to provide the level of access needed to meet resource management objectives as described in the RMOs.

-
- Use applicable practices of BMP AqEco-2 (Operations in Aquatic Ecosystems) when working in or near waterbodies.
 - Use crossing structures suitable for the site conditions and the RMOs.
 - Design and locate crossings to minimize disturbance to the waterbody.
 - Use suitable measures to locate, construct, and decommission or stabilize bypass roads to avoid, minimize, or mitigate adverse effects to soil, water quality, and riparian resources.
 - Use suitable surface drainage and roadway stabilization measures to disconnect the road from the waterbody to avoid or minimize water and sediment from being channeled into surface waters and to dissipate concentrated flows.
 - Use suitable measures to avoid, minimize, or mitigate damage to the waterbody and banks when transporting materials across the waterbody or AMZ during construction activities.

Stream Crossings

- Locate stream crossings where the channel is narrow, straight, and uniform, and has stable soils and relatively flat terrain to the extent practicable.
 - ┆ Select a site where erosion potential is low.
 - ┆ Orient the stream crossing perpendicular to the channel to the extent practicable.
 - ┆ Keep approaches to stream crossings to as gentle a slope as practicable.
 - ┆ Consider natural channel adjustments and possible channel location changes over the design life of the structure.
- Design the crossing to pass a normal range of flows for the site.
 - ┆ Design the crossing structure to have sufficient capacity to convey the design flow without appreciably altering streamflow characteristics.
 - ┆ Install stream crossings to sustain bankfull dimensions of width, depth, and slope and maintain streambed and bank resiliency and continuity through the structure.
- Bridge, culvert, or otherwise design road fill to prevent restriction of flood flows.
 - ┆ Use site conditions and local requirements to determine design flood flows.
 - ┆ Use suitable measures to protect fill from erosion and to avoid or minimize failure of the crossing at flood flows.
 - ┆ Use suitable measures to provide floodplain connectivity to the extent practicable.
- Use suitable measures to avoid or minimize scour and erosion of the channel, crossing structure, and foundation to maintain the stability of the channel and banks.
- Design and construct the stream crossing to maintain the desired migration or other movement of fish and other aquatic life inhabiting the waterbody.
 - ┆ Consider the use of bottomless arch culverts where appropriate to allow for natural channel migration and desired aquatic organism passage.
 - ┆ Install or maintain fish migration barriers only where needed to protect endangered, threatened, sensitive, or unique native aquatic populations, and only where natural barriers do not exist.
 - ┆ Use stream simulation techniques where practicable to aid in crossing design.

-
- Bridges
 - ↳ Use an adequately long bridge span to avoid constricting the natural active flow channel and minimize constriction of any overflow channel.
 - ↳ Place foundations onto nonscour-susceptible material (e.g., bedrock or coarse rock material) or below the expected maximum depth of scour.
 - ↳ Set bridge abutments or footings into firm natural ground (e.g., not fill material or loose soil) when placed on natural slopes.
 - ↳ Use suitable measures as needed in steep, deep drainages to retain approach fills or use a relatively long bridge span.
 - ↳ Avoid placing abutments in the active stream channel to the extent practicable.
 - ↳ Place in-channel abutments in a direction parallel to the streamflow where necessary.
 - ↳ Use suitable measures to avoid or minimize, to the extent practicable, damage to the bridge and associated road from expected flood flows, floating debris, and bedload.
 - ↳ Inspect the bridge at regular intervals and perform maintenance as needed to maintain the function of the structure.
 - Culverts
 - ↳ Align the culvert with the natural stream channel.
 - ↳ Cover culvert with sufficient fill to avoid or minimize damage by traffic.
 - ↳ Construct at or near natural elevation of the streambed to avoid or minimize potential flooding upstream of the crossing and erosion below the outlet.
 - ↳ Install culverts long enough to extend beyond the toe of the fill slopes to minimize erosion.
 - ↳ Use suitable measures to avoid or minimize water from seeping around the culvert.
 - ↳ Use suitable measures to avoid or minimize culvert plugging from transported bedload and debris.
 - ↳ Regularly inspect culverts and clean as necessary.
 - Low-Water Crossings
 - ↳ Consider low-water crossings on roads with low traffic volume and slow speeds, and where water depth is safe for vehicle travel.
 - ↳ Consider low-water crossings to cross ephemeral streams, streams with relatively low baseflow and shallow water depth or streams with highly variable flows or in areas prone to landslides or debris flows.
 - ↳ Locate low-water crossings where streambanks are low with gentle slopes and channels are not deeply incised.
 - ↳ Select and design low-water crossing structures to maintain the function and bedload movement of the natural stream channel.
 - ↳ Locate unimproved fords in stable reaches with a firm rock or gravel base that has sufficient load-bearing strength for the expected vehicle traffic.
 - ↳ Construct the low-water crossing to conform to the site, channel shape, and original streambed elevation and to minimize flow restriction, site disturbance, and channel blockage to the extent practicable.
 - ↳ Use suitable measures to stabilize or harden the streambed and approaches, including the entire bankfull width and sufficient freeboard, where necessary to support the design vehicle traffic.

-
- ↳ Use vented fords with high vent area ratio to maintain stream function and aquatic organism passage.
 - ↳ Construct the roadway-driving surface with material suitable to resist expected shear stress or lateral forces of water flow at the site.
 - ↳ Consider using temporary crossings on roads that provide short-term or intermittent access to avoid, minimize, or mitigate erosion, damage to streambed or channel, and flooding.
 - ↳ Design and install temporary crossings suitable for the expected users, loads, and timing of use.
 - ↳ Design and install temporary crossing structures to pass a design storm determined based on local site conditions and requirements.
 - ↳ Install and remove temporary crossing structures in a timely manner as needed to provide access during use periods and minimize risk of washout.
 - ↳ Use suitable measures to stabilize temporary crossings that must remain in place during high runoff seasons.
 - ↳ Monitor temporary crossings regularly while installed to evaluate condition.
 - ↳ Remove temporary crossings and restore the waterbody profile and substrate when the need for the crossing no longer exists.

Standing Water and Wetland Crossings

- Disturb the least amount of area as practicable when crossing a standing waterbody.
- Provide for sufficient cross drainage to minimize changes to, and avoid restricting, natural surface and subsurface water flow of the wetland under the road to the extent practicable.
 - ↳ Locate and design roads or road drainage to avoid dewatering or polluting wetlands.
 - ↳ Avoid or minimize actions that would significantly alter the natural drainage for flow patterns on lands immediately adjacent to wetlands.
- Use suitable measures to increase soil-bearing capacity and reduce rutting from expected vehicle traffic.
- Construct fill roads only when necessary.
 - ↳ Construct fill roads parallel to water flow and to be as low to natural ground level as practicable.
 - ↳ Construct roads with sufficient surface drainage for surface water flows.

Road-8. Snow Removal and Storage

Manual or Handbook

Reference FS-7700-41 and FSH 7709.59, chapter 24.11.

Objective Avoid or minimize erosion, sedimentation, and chemical pollution that may result from snow removal and storage activities.

Explanation Snow removal from roads and parking areas may adversely affect water quality and riparian resources in several ways. Plowing may physically displace native or engineered surfaces on roads, damage drainage structures, or alter drainage patterns. Plowing may also remove protective soil cover (e.g., vegetation or mulch). These changes can result in concentrated flow, increased erosion, and greater risk of sediment delivery to waterbodies.

Snow piled in large mounds or berms, or in sensitive areas, may contribute to increased run-off, hill slope erosion, mass slope instability, and in-channel erosion from snowmelt. Snow stored in riparian areas and floodplains may compact soils, break or stunt vegetation, or channel runoff in undesirable patterns, thereby weakening the buffering capacity of these areas. Additionally, both snow removal and storage may result in additions of salts or fine aggregates used for de-icing or traction control and other vehicle pollutants directly to surface water and indirectly to both surface water and groundwater during runoff.

Practices Develop site-specific BMP prescriptions for the following practices, as appropriate or when required, using State BMPs, Forest Service regional guidance, land management plan direction, BMP monitoring information, and professional judgment.

- Develop a snow removal plan for roads plowed for recreation, administrative, or other access to avoid, minimize, or mitigate adverse effects to soil, water quality, and riparian resources.
- Use existing standard contract language (C5.316# or similar) for snow removal during winter logging operations to avoid, minimize, or mitigate adverse effects to soil, water quality, and riparian resources.
- Limit use of approved deicing and traction control materials to areas where safety is critical (e.g., intersections, steep segments, and corners).
 - ↳ Use site-specific characteristics such as road width and design, traffic concentration, and proximity to surface waters to determine suitable amount of de-icing material to apply.
 - ↳ Use effective plowing techniques to optimize chemical de-icer use.
 - ↳ Consider use of alternative materials to chemical de-icers, such as sand or gravel, in sensitive areas.
 - ↳ Use properly calibrated controllers to ensure material application rates are accurately regulated.
 - ↳ Limit spray distribution of chemical de-icers when near surface waters.
 - ↳ Design paved roads and parking lots to facilitate sand removal (e.g., curbs or paved ditches).
- Use suitable measures when storing de-icing materials to avoid or minimize mobility of the materials.
 - ↳ Store de-icing materials on a flat, upland, impervious area of adequate size to accommodate material stockpiles and equipment movement.
 - ↳ Stockpile de-icing materials under cover and provide runoff collection, containment, and treatment, as necessary, to avoid or minimize offsite movement.
- Move snow in a manner that will avoid or minimize disturbance of or damage to road surfaces and drainage structures.
 - ↳ Mark drainage structures to avoid damage during plowing.
 - ↳ Conduct frequent inspections to ensure road drainage is not adversely affecting soil or water resources.
- Control areas where snow removal equipment can operate to avoid or minimize damage to riparian areas, floodplains, and stream channels.
- Install snow berms where such placement will preclude concentration of snowmelt runoff and will serve to dissipate melt water.
 - ↳ Provide frequent drainage through snow berms to avoid concentration of snowmelt runoff on fillslopes and other erosive areas, to dissipate melt water, and to avoid or minimize sediment delivery to waterbodies.

-
- Store snow in clearly delineated pre-approved areas where snowmelt runoff will not cause erosion or deliver snow, road de-icers, or traction-enhancing materials directly into surface waters.
 - ↳ Store or dispose of snow adjacent to or on pervious surfaces in upland areas away from waterbodies to the extent practicable.
 - ↳ Do not store or dispose of snow in riparian areas, wetlands, or streams unless no other practicable alternative exists.
 - Manage discharge of meltwater to avoid or minimize runoff of pollutants into surface waterbodies or groundwater.
 - ↳ Use suitable measures to filter and treat meltwater before reaching surface water or groundwater.
 - ↳ Use suitable measures to disperse meltwater to avoid creating concentrated overland flow.
 - ↳ Collect and properly dispose of onsite litter, debris, and sediment from meltwater settling areas.
 - Discontinue road use and snow removal when use would likely damage the roadway surface or road drainage features.
 - ↳ Modify snow removal procedures as necessary to meet water quality concerns.
 - Replace lost road surface materials with similar quality material and repair structures damaged in snow removal operations as soon as practicable.

Road-9. Parking and Staging Areas

Manual or Handbook

Reference FSM 7710, FSM 7720, and FSM 7730.

Objective Avoid, minimize, or mitigate adverse effects to soil, water quality, and riparian resources when constructing and maintaining parking and staging areas.

Explanation Parking and staging areas on NFS lands may be permanent or temporary and are associated with a variety of uses including administrative buildings, developed recreation sites, trailheads, and forest management projects. These parking facilities sometimes constitute large areas with little or no infiltration capacity. Runoff from these areas can create rills or gullies and carry sediment, nutrients, and other pollutants to nearby surface waters.

Practices Develop site-specific BMP prescriptions for the following practices, as appropriate or when required, using State BMPs, Forest Service regional guidance, land management plan direction, BMP monitoring information, and professional judgment.

- Design and locate parking and staging areas of appropriate size and configuration to accommodate expected vehicles and avoid or minimize adverse effects to adjacent soil, water quality, and riparian resources.
 - ↳ Consider the number and type of vehicles to determine parking or staging area size.
- Use applicable practices of BMP Fac-2 (Facility Construction and Stormwater Control) for stormwater management and erosion control when designing, constructing, reconstructing, or maintaining parking or staging areas.
- Use suitable measures to harden and avoid or minimize damage to parking area surfaces that experience heavy use or are used during wet periods.

-
- Use and maintain suitable measures to collect and contain oil and grease in larger parking lots with high use and where drainage discharges directly to streams.
 - Connect drainage system to existing stormwater conveyance systems where available and practicable.
 - Conduct maintenance activities commensurate with parking or staging area surfacing and drainage requirements as well as precipitation timing, intensity, and duration.
 - Limit the size and extent of temporary parking or staging areas.
 - ┆ Take advantage of existing openings, sites away from waterbodies, and areas that are apt to be more easily restored to the extent practicable.
 - ┆ Use temporary stormwater and erosion control measures as needed.
 - ┆ Use applicable practices of BMP Fac-10 (Facility Site Reclamation) to rehabilitate temporary parking or staging areas as soon as practicable following use.

Road-10. Equipment Refueling and Servicing

Manual or Handbook

Reference FSM 2160 and FSH 7109.19, chapter 40.

Objective Avoid or minimize adverse effects to soil, water quality, and riparian resources from fuels, lubricants, cleaners, and other harmful materials discharging into nearby surface waters or infiltrating through soils to contaminate groundwater resources during equipment refueling and servicing activities.

Explanation Many activities require the use and maintenance of petroleum-powered equipment in the field. For example, mechanical vegetation management activities may employ equipment that uses or contains gasoline, diesel, oil, grease, hydraulic fluids, antifreeze, coolants, cleaning agents, and pesticides. These petroleum and chemical products may pose a risk to contaminating soils, surface water, and groundwaters during refueling and servicing the equipment. BMP Fac-6 (Hazardous Materials) provides additional guidance for handling hazardous materials.

Practices Develop site-specific BMP prescriptions for the following practices, as appropriate or when required, using State BMPs, Forest Service regional guidance, land management plan direction, BMP monitoring information, and professional judgment.

- Plan for suitable equipment refueling and servicing sites during project design.
 - ┆ Allow temporary refueling and servicing only at approved locations, located well away from the AMZ, groundwater recharge areas, and waterbodies.
- Develop or use existing fuel and chemical management plans (e.g., Spill Prevention Control and Countermeasures [SPCC], spill response plan, and emergency response plan) when developing the management prescription for refueling and servicing sites.
- Locate, design, construct, and maintain petroleum and chemical delivery and storage facilities consistent with applicable local, State, and Federal regulations.
- Use suitable measures around vehicle service, storage and refueling areas, chemical storage and use areas, and waste dumps to fully contain spills and avoid or minimize soil contamination and seepage to groundwater.
- Provide training for all agency personnel handling fuels and chemicals in their proper use, handling, storage, and disposal.

-
- ↳ Ensure that contractors and permit holders provide documentation of proper training in handling hazardous materials.
 - Use suitable measures to avoid spilling fuels, lubricants, cleaners, and other chemicals during handling and transporting.
 - Prohibit excess chemicals or wastes from being stored or accumulated in the project area.
 - Remove service residues, used oil, and other hazardous or undesirable materials from NFS land and properly dispose them as needed during and after completion of the project.
 - Clean up and dispose of spilled materials according to specified requirements in the appropriate guiding document.
 - Report spills and initiate suitable cleanup action in accordance with applicable State and Federal laws, rules, and regulations.
 - ↳ Remove contaminated soil and other material from NFS lands and dispose of this material in a manner consistent with controlling regulations.
 - Prepare and implement a certified SPCC Plan for each facility, including mobile and portable facilities, as required by Federal regulations.
 - Use applicable practices of BMP Fac-10 (Facility Site Reclamation) to reclaim equipment refueling and services site when the need for them ends.

Road-11. Road Storm-Damage Surveys

Manual or Handbook

Reference FSM 7730 and FSM 2350.

Objective Monitor road conditions following storm events to detect road failures; assess damage or potential damage to waterbodies, riparian resources, and watershed functions; determine the causes of the failures; and identify potential remedial actions at the damaged sites and preventative actions at similar sites.

Explanation Large storms stress road systems in multiple ways: large volumes of water are transported on road surfaces and through its drainage systems; significant volumes of water and debris are transported through stream crossings; and elevated pore pressures on unstable hillslopes, road cutslopes, and fillslopes sometimes generate mass failures. All road drainage systems, stream crossings with culverts, and unstable slopes have the potential to fail during periods of high runoff. The probabilities of failure differ greatly, and the potential consequences to water quality and designated uses vary dramatically from no impacts to severe and long-term impacts to aquatic systems.

Surveying roads during or soon after storms is critical to timely detection of these problems. Observation of problems caused by storm runoff is of great value in understanding both the causes of failure and in adapting designs and prescriptions that reduce both the probability and consequences of future road failures. Over time, this kind of monitoring illustrates how and where roads can fail and points readily to practice modifications that can reduce adverse effects to water quality and watershed function.

The Emergency Relief for Federally Owned Roads (ERFO) Program is intended to help assess and fund the unusually heavy expenses associated with repairing and reconstructing Federal roads and bridges seriously damaged by a natural disaster over a wide area or catastrophic failure. To qualify for this type of funding, applications for repair must be submitted to the Federal Highways Administration through the ERFO program (FSM 7700).

Practices *ERFO-Related Damage Surveys*

- Complete a Damage Survey Report (DSR) at damaged sites potentially eligible for ERFO funds.
- Complete the Forest Service-developed supplemental form DSR+ in the field to more thoroughly describe, in categorical terms, the cause(s) and consequences of the damage.
 - ┆ The DSR+ form and instructions may be found at <http://www.stream.fs.fed.us/bmp/damagesurveys>.
- Record the following information from damage sites that have been documented on the DSR and DSR+ forms in appropriate corporate database(s), including geographic information systems:
 - ┆ The geographic locations (points or road segments) where damage occurred.
 - ┆ The date of occurrence (year and month, if available).
 - ┆ The type of failure and its cause.

Special Storm Damage Surveys

- Determine the need to do more comprehensive surveys and analysis of road damage after particularly large storm events.
 - ┆ Survey all roads in the area, typically an entire watershed, ranger district, or national forest or grassland, affected by the storm or those roads that may be particularly susceptible to failure.

All Damage Surveys

- Analyze results from ERFO surveys, routine damage reconnaissance, and special surveys for patterns of damage and causes.
- Use these patterns of road damage to formulate recommendations of practice changes to reduce the incidence of future damage. Consider practice changes such as—
 - ┆ Locating or relocating roads to more stable terrain (see BMP Road-2 [Road Location and Design]);
 - ┆ Disconnecting road surface drainage from crossings and channels (see BMP Road-3 [Road Construction and Reconstruction]);
 - ┆ Using special protections in locations on unstable landforms or areas with high erosion potential (see BMP Road-3 [Road Construction and Reconstruction]);
 - ┆ Increasing the capacity of stream-crossing structures to pass water, debris, and sediment to reduce the probabilities of failure (see BMP Road-7 [Stream Crossings]);
 - ┆ Building or rebuilding stream crossings to eliminate or reduce diversion potential (see BMP Road-7 [Stream Crossings]);
 - ┆ Building or rebuilding stream crossings to improve aquatic species passage (see BMP Road-7 [Stream Crossings]); or
 - ┆ Decommissioning or storing roads in a hydrologically benign condition (see BMP Road-6 [Road Storage and Decommissioning]).
- Enter and store the results of data analysis in corporate data management systems to facilitate sharing among units that have similar terrain and road practices.

Resources for Road Management Activities

- Aquatic Passage** Clarkin, K.; et al. 2008. Stream simulation: An ecological approach to providing passage for aquatic organisms at road-stream crossings. 0877 1801-SDTDC. San Dimas, CA: USDA Forest Service, Technology and Development Program. Available at <http://www.fs.fed.us/eng/pubs/pdf/StreamSimulation/index.shtml>.
- Furniss, M.; Love, M.; Firor, S.; Moynan, K.; Llanos, A.; Guntle, J.; Gubernick, R. 2006. FishXing—Software and learning systems for fish passage through culverts version 3. San Dimas, CA: U.S. Department of Agriculture (USDA), Forest Service, Technology and Development Program. Available at <http://stream.fs.fed.us/fishxing/index.html>.
- Crossings** Blinn, C.R.; Dahlman, R.; Hislop, L.; Thompson, M. 1998. Temporary stream and wetland crossing options for forest management. Gen. Tech. Rep. NC-202. St. Paul, MN: USDA Forest Service, North Central Forest Experiment Station. 136 p. Available at <http://nrs.fs.fed.us/pubs/266>.
- Cafferata, P.; Spittler, T.; Wopat, M.; Bundros, G.; Flanagan, S. 2004. Designing watercourse crossings for passage of 100-year flood flows, wood and sediment. California Forestry Report 1. Sacramento, CA: State of California, The Resources Agency, Department of Forestry and Fire Prevention. 34 p. Available at <http://www.fire.ca.gov/resourcemanagement/pdf/100yr32links.pdf>.
- Clarkin, K.; Keller, G.; Warhol, T.; Hixson, S. 2006. Low-water crossings: Geomorphic, biological, and engineering design considerations. 0625 1808P. San Dimas, CA: USDA Forest Service, Technology and Development Program. 366 p. Available at <http://www.fs.fed.us/eng/pubs/pdf/LowWaterCrossings/index.shtml>.
- USDA Natural Resources Conservation Service (NRCS). National conservation practice standards—396 fish passage, 578 stream crossing. Available at <http://www.nrcs.usda.gov/technical/standards/nhcp.html>.
- Erosion Control** California Department of Transportation. 2003. Construction sites best management practices (BMP) field manual and troubleshooting guide. 147 p. Available at <http://www.dot.ca.gov/hq/construc/stormwater/manuals.htm>.
- Rivas, T. 2006. Erosion control selection guide. 0677-1203-SDTDC. San Dimas, CA: USDA Forest Service, Technology and Development Program. 64 p. Available at http://fsweb.sdtc.wo.fs.fed.us/pubs/pdf/hi_res/06771203hi.pdf.
- General** Male, P. 2010. The basics of a good road. CLRP Report No. 08-06. Ithaca, NY: Cornell University Local Roads Program. 96 p. Available at http://www.clrp.cornell.edu/workshops/pdf/basics_of_a_good_road-2010-web.pdf.
- Meitl, J.; Maguire, T. (Eds.). 2003. Compendium of best management practices to control polluted runoff: A source book. Boise, ID: Idaho Department of Environmental Quality. Available at http://www.deq.State.id.us/water/data_reports/surface_water/nps/reports.cfm#bmps.
- USDOT Federal Highways Administration. 2003. Standard specifications for construction of roads and bridges on Federal highway projects. FP-03. Washington, DC. 699 p. Available at <http://fhwa.dot.gov/resources/pse/specs/>.

USDA Forest Service. Water/road interaction series. San Dimas, CA: USDA Forest Service, Technology and Development Program. Available at <http://www.fs.fed.us/eng/pubs/>.

U.S. Environmental Protection Agency (EPA), Office of Water. 2005. National management measures to control nonpoint source pollution from forestry. EPA 841-B-05-001. Washington, DC. Available at <http://www.epa.gov/owow/nps/forestrygmt/>.

Low-Volume Roads American Association of State Highway and Transportation Officials (AASHTO). 2001. Guidelines for geometric design of very low-volume local roads (ADT<400). ISBN 1-56051-166-4. Washington, DC. 72 p. Available at <http://www.transportation.org>.

Keller, G.; Sherar, J. 2003. Low-volume roads engineering—Best management practices field guide. Washington, DC: USDA Forest Service, Office of International Programs, and U.S. Agency for International Development. 158 p. Available at <http://www.fs.fed.us/global/topic/welcome.htm#12>.

Road Maintenance Anderson, J.A.; Gesford, A.L. 2007. Environmentally sensitive maintenance for dirt and gravel roads. Harrisburg, PA: Pennsylvania Department of Transportation. 332 p. Available at <http://www.epa.gov/owow/NPS/sensitive/sensitive.html>.

Road Decommissioning Moll, J. 1996. A guide for road closure and obliteration in the Forest Service. 9677 1205. San Dimas, CA: USDA Forest Service, Technology and Development Program. 53 p. Available at <http://fswb.sdtc.wo.fs.fed.us/pubs/pdfimage/96771205.pdf>.

USDA Forest Service, Roads/Riparian Team. 2002. Management and practices for riparian restorations: Roads field guide volumes I and II. Gen. Tech. Rep. RMRS-102. Fort Collins, CO: USDA Forest Service, Rocky Mountain Research Station. 23 p. and 31 p. Available at <http://www.fs.fed.us/rm/publications>.

USDA Forest Service, National Riparian Roads Team. 2005. Riparian restoration: A roads field guide. 0577 1801P. San Dimas, CA: USDA Forest Service, Technology and Development Program. 128 p. Available at <http://fswb.sdtc.wo.fs.fed.us/pubs/pdf/05771801.pdf>.

USDA NRCS. National conservation practice standards—654 road/trail/landing closure and treatment. Available at <http://www.nrcs.usda.gov/technical/standards/nhcp.html>.

State Forestry BMP

Documents See Appendix B.

Mechanical Vegetation Management Activities

The purpose of this set of Best Management Practices (BMPs) is to avoid, minimize, or mitigate adverse effects to soil, water quality, and riparian resources that may result from mechanical treatments to manage vegetation. Mechanical treatments are used to manage vegetation for a variety of purposes including timber harvest, site preparation, vegetation type conversion, fire or fuels treatment, forest health and rangeland improvement, and wildlife habitat improvement. Authorizing documents for mechanical treatments are timber sale contracts, stewardship contracts, or project plans.

Eight National Core BMPs are in the Mechanical Vegetation Management Activities category. These BMPs are to be used in all mechanical vegetation management projects on National Forest System (NFS) lands. BMP Veg-1 (Vegetation Management Planning) is a planning BMP for vegetation management projects. BMP Veg-2 (Erosion Prevention and Control) provides direction for erosion control measures for mechanical vegetation treatment projects. BMP Veg-3 (Aquatic Management Zones) provides direction for mechanical vegetation treatments in the areas adjacent to waterbodies. BMP Veg-4 (Ground-Based Skidding and Yarding Operations) and BMP Veg-5 (Cable and Aerial Yarding Operations) provide direction for yarding activities in timber management projects. BMP Veg-6 (Landings) provides direction for construction and use of landings. BMP Veg-7 (Winter Logging) provides additional direction for skidding and yarding operations in winter. BMP Veg-8 (Mechanical Site Treatment) provides practices for other mechanical vegetation treatments for site preparation, fuel treatment, and habitat improvements.

States will be used in the rest of this resource category to signify both States and those tribes that have received approval from the U.S. Environmental Protection Agency (EPA) for treatment as a State under the Clean Water Act (CWA).

Mechanical Vegetation Management BMPs	
Veg-1	Vegetation Management Planning
Veg-2	Erosion Prevention and Control
Veg-3	Aquatic Management Zones
Veg-4	Ground-Based Skidding and Yarding Operations
Veg-5	Cable and Aerial Yarding Operations
Veg-6	Landings
Veg-7	Winter Logging
Veg-8	Mechanical Site Treatment

Veg-1. Vegetation Management Planning

Manual or Handbook

Reference Forest Service Manual (FSM) 1921.12.

Objective Use the applicable vegetation management planning processes to develop measures to avoid, minimize, or mitigate adverse effects to soil, water quality, and riparian resources during mechanical vegetation treatment activities.

Explanation Vegetation on NFS lands is managed for a variety of purposes to achieve land management plan desired conditions, goals, and objectives for many resources. Planning for vegetation management generally follows a sequence of steps. The gathering and assessment of data involves evaluating the current condition of the vegetation compared to land management plan desired conditions, goals,

and objectives. Potential vegetation treatment options to move the site towards desired conditions are developed and compared. Detailed treatment prescriptions are prepared to implement the preferred treatment option. The project is subjected to the National Environmental Policy Act (NEPA) analysis process where alternatives are developed and effects are analyzed. A decision is made and implemented. During the development of vegetation treatment prescriptions and alternatives, site specific measures consistent with BMP guidance to avoid, minimize, or mitigate adverse effects to soil, water quality, and riparian resource are identified and included in the project as design criteria or mitigation measures. These BMP prescriptions are incorporated into the timber sale contract, stewardship contract, or project plan.

Vegetation management for scheduled timber harvest on NFS lands has additional specific requirements from the National Forest Management Act that are incorporated into the project in the planning process. Scheduled timber harvest can occur only where watershed conditions will be maintained, lands can be adequately restocked within 5 years after final regeneration harvest, and water quality will be protected.

Practices Develop site-specific BMP prescriptions for the following practices, as appropriate or when required, using State BMPs, Forest Service regional guidance, land management plan direction, BMP monitoring information, and professional judgment.

- Use applicable practices of BMP Plan-2 (Project Planning and Analysis) and BMP Plan-3 (Aquatic Management Zone (AMZ) Planning) when planning vegetation management projects.
 - ┆ Evaluate opportunities to use proposed mechanical vegetation treatment projects to achieve AMZ desired conditions, goals, and objectives in the project area.
- Evaluate and field verify site conditions in the project area to design mechanical vegetation treatment prescriptions that avoid, minimize, or mitigate adverse effects to soil, water quality, and riparian resources.
 - ┆ Validate land management plan timber suitability decisions for the project area.
 - ┆ Design mechanical vegetation treatment prescriptions to limit site disturbance, soil exposure, and displacement to acceptable levels as determined from the land management plan desired conditions, standards, and guidelines or other local direction or requirements.
 - ┆ Evaluate direct, indirect, and cumulative effects of vegetation alteration on streamflow regimes and consequent channel responses at suitable watershed scales.
 - ┆ Use local direction or requirements for slope, erosion potential, mass wasting potential, and other soil or site properties to determine areas suitable for ground-based, cable, and aerial yarding systems (see BMP Veg-4 [Ground-Based Skidding and Yarding Operations] and BMP Veg-5 [Cable and Aerial Yarding Operations]).
 - ┆ Use the most economically practicable yarding system that will minimize road densities.
 - ┆ Consider site preparation and fuel treatment needs and options.
 - ┆ Use applicable practices of BMP Veg-8 (Mechanical Site Treatment) to determine areas suitable for mechanical treatments for site preparation, fuels treatment, habitat improvements, or other vegetation management purposes.
 - ┆ Evaluate the capabilities of the machinery likely to operate in the landscape under consideration.
 - ┆ Use preplanning to schedule entry or timing of mechanical and other vegetation treatments (e.g., prescribed fire or chemical treatments) when needed for large projects.

-
- Evaluate and field verify site conditions in the project area to design a transportation plan associated with the mechanical vegetation treatments to avoid, minimize, or mitigate adverse effects to soil, water quality, and riparian resources.
 - ┆ Use the logging system that best fits the topography, soil types, and season, while minimizing soil disturbance and road densities and that economically achieves silvicultural objectives.
 - ┆ Use applicable practices of BMP Road-2 (Road Location and Design), BMP Veg-4 (Ground-Based Skidding and Yarding Operations), BMP Veg-5 (Cable and Aerial Yarding Operations), and BMP Veg-6 (Landings) to determine proposed location and size of roads, landings, skid trails, and cable corridors.
 - ┆ Use applicable practices of BMP Road-1 (Travel Management Planning and Analysis) and BMP Road-5 (Temporary Roads) to determine the need for specified roads and temporary roads.
 - ┆ Evaluate the condition of system roads, including roads in storage, and unauthorized roads in the project area to determine their suitability for use in the project and any reconstruction or prehaul maintenance needs.
 - ┆ Evaluate the Road Management Objective of system roads to determine where log hauling should be prohibited or restricted.
 - Identify sources of rock for roadwork, riprapping, and borrow materials (see BMP Min-6 [Mineral Materials Resource Sites]).
 - Identify water sources available for purchasers' use (see BMP WatUses-3 [Administrative Water Developments]).
 - Ensure the timber sale contract, stewardship contract, or other implementing document includes BMPs from the decision document to avoid, minimize, or mitigate adverse effects to soil, water quality, and riparian resources.
 - ┆ Use appropriate standard B and C provisions and regional or local provisions to address measures and responsibilities consistent with the BMPs in the decision document in the timber sale or stewardship contract.
 - ┆ Delineate all protected or excluded areas, including AMZs and waterbodies, on the sale area map or project map.
 - ┆ Delineate approved water locations, staging areas, and borrow areas on the sale area map or project map.
 - ┆ Ensure that the final unit location, layout, acreage, and logging system or mechanical treatment and Knutson-Vandenberg Act plans are consistent with the decision document.
 - Use contract modification procedures to the extent practicable to modify unit design, treatment methods, or other project activities where necessary to avoid, minimize, or mitigate adverse effects to soil, water quality, and riparian resources based on new information or changed conditions discovered during project implementation.

Veg-2. Erosion Prevention and Control

Manual or Handbook

Reference Forest Service Handbook (FSH) 2409.15.

Objective Avoid, minimize, or mitigate adverse effects to soil, water quality, and riparian resources by implementing measures to control surface erosion, gully formation, mass slope failure, and resulting sediment movement before, during, and after mechanical vegetation treatments.

Explanation Prevention and control of erosion on areas undergoing mechanical vegetation treatments is critical to maintaining water quality. The process of erosion control has three basic phases: planning, implementation, and monitoring. During planning, areas subject to excessive erosion, detrimental soil damage and mass failure can be identified and avoided. Also during planning, treatments can be designed and units laid out to minimize or mitigate damage to soils, streambanks, shorelines, wetlands, riparian areas, and water quality. Planning for erosion control is addressed in BMP Plan-2 (Project Planning and Analysis) and BMP Veg-1 (Vegetation Management Planning). Suitable erosion control measures are implemented while the mechanical vegetation treatment is ongoing and following project completion. Inspection and maintenance of implemented measures will ensure their function and effectiveness over their expected design period.

The potential for accelerated erosion or other soil damage during or following mechanical treatments depends on climate, soil type, site conditions, and type of equipment and techniques used at the site. Erosion control measures are grouped into two general categories: structural measures to control and treat runoff and increase infiltration and nonstructural measures to increase ground cover. Many erosion control handbooks, technical guides, and commercial products are available. Both structural and nonstructural measures require onsite expertise to ensure proper design and implementation to conform to local site characteristics.

Practices Develop site-specific BMP prescriptions for the following practices, as appropriate or when required, using State BMPs, Forest Service regional guidance, land management plan direction, BMP monitoring information, and professional judgment.

- Establish designated areas for equipment staging and parking to minimize the area of ground disturbance (see BMP Road-9 [Parking Sites and Staging Areas]).
- Use provisions in the timber sale contract or land stewardship contract to implement and enforce erosion control on the project area.
 - ┆ Work with the contractor to locate landings, skid trails, and slash piles in suitable sites to avoid, minimize, or mitigate potential for erosion and sediment delivery to nearby waterbodies.
- Develop an erosion control and sediment plan that covers all disturbed areas including skid trails and roads, landings, cable corridors, temporary road fills, water source sites, borrow sites, or other areas disturbed during mechanical vegetation treatments.
- Refer to State or local forestry or silviculture BMP manuals, guidebooks, and trade publications for effective structural and nonstructural measures to—
 - ┆ Apply soil protective cover on disturbed areas where natural revegetation is inadequate to prevent accelerated erosion before the next growing season.
 - ┆ Maintain the natural drainage pattern of the area wherever practicable.
 - ┆ Control, collect, detain, treat, and disperse stormwater runoff from disturbed areas.
 - ┆ Divert surface runoff around bare areas with appropriate energy dissipation and sediment filters.
 - ┆ Stabilize steep excavated slopes.

-
- Use suitable species and establishment techniques to cover or revegetate disturbed areas in compliance with local direction and requirements per FSM 2070 and FSM 2080 for vegetation ecology and prevention and control of invasive species.
 - Use suitable measures in compliance with local direction to prevent and control invasive species.
 - Install sediment and stormwater controls before initiating surface-disturbing activities to the extent practicable.
 - Operate equipment when soil compaction, displacement, erosion, and sediment runoff would be minimized.
 - ↳ Avoid ground equipment operations on unstable, wet, or easily compacted soils and on steep slopes unless operation can be conducted without causing excessive rutting, soil puddling, or runoff of sediments directly into waterbodies.
 - ↳ Evaluate site conditions frequently to assess changing conditions.
 - ↳ Adjust equipment operations as necessary to protect the site while maintaining efficient project operations.
 - Install suitable stormwater and erosion control measures to stabilize disturbed areas and waterways on incomplete projects before seasonal shutdown of operations or when severe storm or cumulative precipitation events that could result in sediment mobilization to waterbodies are expected.
 - Routinely inspect disturbed areas to verify that erosion and stormwater controls are implemented and functioning as designed and are suitably maintained.
 - Maintain erosion and stormwater controls as necessary to ensure proper and effective functioning.
 - ↳ Prepare for unexpected failures of erosion control measures.
 - Implement mechanical treatments on the contour of sloping ground to avoid or minimize water concentration and subsequent accelerated erosion.

Veg-3. Aquatic Management Zones

Manual or Handbook

Reference FSM 2526, FSM 2527.

Objective Avoid, minimize, or mitigate adverse effects to soil, water quality, and riparian resources when conducting mechanical vegetation treatment activities in the AMZ.

Explanation Designation of an AMZ around and adjacent to waterbodies is a typical BMP to avoid, minimize, or mitigate adverse effects to soil, water quality, and riparian resources. Mechanical vegetation treatments are a tool that can be used within the AMZ to achieve a variety of resource-desired conditions and objectives when implemented with suitable measures to maintain riparian and aquatic ecosystem structure, function, and processes. Depending on site conditions and resource-desired conditions and objectives, mechanical vegetation treatments in the AMZ could range from no activity or equipment exclusion to purposely using mechanical equipment to create desired disturbances or conditions. When treatments are to be used in the AMZ, a variety of measures can be employed to avoid, minimize, or mitigate soil disturbance, damage to the waterbody, loss of large woody debris recruitment, and shading, and impacts to floodplain function.

Practices Develop site-specific BMP prescriptions for the following practices, as appropriate or when required, using State BMPs, Forest Service regional guidance, land management plan direction, BMP monitoring information, and professional judgment.

-
- Use applicable practices of BMP Plan-3 (AMZ Planning) to determine the need for and width of the AMZ considering the proposed mechanical vegetation treatments.
 - ┆ Modify AMZ width as needed to provide assurance of leave-tree wind firmness where high windthrow risk is identified.
 - Clearly delineate AMZ locations and boundaries in the project area using suitable markings and structures.
 - ┆ Maintain or reestablish these boundaries as necessary during project implementation or operation.
 - ┆ Specify AMZ layout, maintenance, and operating requirements in contracts, design plans, and other necessary project documentation.
 - Use mechanical vegetation treatments in the AMZ only when suitable to achieve long-term AMZ-desired conditions and management objectives (see BMP Plan-3 [AMZ Planning]).
 - Modify mechanical vegetation treatment prescriptions and operations in the AMZs as needed to maintain ecosystem structure, function, and processes.
 - ┆ Design silvicultural or other vegetation management prescriptions to maintain or improve the riparian ecosystem and adjacent waterbody.
 - ┆ Use yarding systems or mechanical treatments that avoid or minimize disturbance to the ground and vegetation consistent with project objectives.
 - ┆ Conduct equipment operations in a manner that maintains or provides sufficient ground cover to meet land management plan desired conditions, goals, and objectives to minimize erosion and trap sediment.
 - ┆ Use suitable measures to avoid or minimize soil disturbance from equipment operations to stay within acceptable disturbance levels when conducting mechanical vegetation treatment operations.
 - ┆ Prescribe mechanical site preparation techniques and fuels and residual vegetation treatments that avoid or minimize excessive erosion, sediment delivery to nearby waterbodies, or damage to desired riparian vegetation.
 - ┆ Conduct operations in a manner that avoids or minimizes introduction of excess slash or other vegetative debris into the AMZ and waterbodies; damage to streambanks, shorelines, and edges of wetlands; and adverse effects to floodplain functioning.
 - ┆ Retain trees as necessary for canopy cover and shading, bank stabilization, and as a source of large woody debris within the AMZ.
 - ┆ Avoid felling trees into streams or waterbodies, except as planned to create habitat features.
 - Locate transportation facilities for mechanical vegetation treatments, including roads, landings, and main skid trails, outside of the AMZ to the extent practicable.
 - ┆ Minimize the number of stream crossings to the extent practicable.
 - ┆ Evaluate options for routes that must cross waterbodies and choose the one (e.g., specified road vs. temporary road vs. skid road or trail) that avoids or minimizes adverse effects to soil, water quality, and riparian resources to the greatest extent practicable.
 - ┆ Do not use drainage bottoms as turn-around areas for equipment during mechanical vegetation treatments.
 - Use suitable measures to disperse concentrated flows of water from road surface drainage features to avoid or minimize surface erosion, gully formation, and mass failure in the AMZ and sediment transport to the waterbody.

-
- Monitor the AMZ during mechanical operations to evaluate compliance with prescription and mitigation requirements in the authorizing document.
 - ↳ Adjust operations in the AMZ to avoid, minimize, or mitigate detrimental soil impacts where they are occurring.
 - ↳ Use suitable mitigation or restoration measures on areas in the AMZ that show signs of unacceptable erosion or those with high potential for erosion due to mechanical operations in the AMZ.
 - ↳ Remove unauthorized debris from waterbodies using techniques that will limit disturbance to bed and banks, riparian areas, aquatic-dependent species, and the waterbody unless significant damage would occur during its removal or leaving it in meets desired conditions for the waterbody.

Veg-4. Ground-Based Skidding and Yarding Operations

Manual or Handbook

Reference FSH 2409.15.

Objective Avoid, minimize, or mitigate adverse effects to soil, water quality, and riparian resources during ground-based skidding and yarding operations by minimizing site disturbance and controlling the introduction of sediment, nutrients, and chemical pollutants to waterbodies.

Explanation Ground-based yarding systems include an array of equipment from horses, rubber-tired skidders, and bulldozers, to feller or bunchers, forwarders, and harvesters. Each method can compact soil and cause soil disturbance, though the amount of impact depends on the specific type of equipment used, the operator, unit design, and site conditions. Ground-based yarding systems can be designed and implemented to avoid, minimize, or mitigate potential adverse effects to soils, water quality, and riparian resources.

Practices Develop site-specific BMP prescriptions for the following practices, as appropriate or when required, using State BMPs, Forest Service regional guidance, land management plan direction, BMP monitoring information, and professional judgment.

- Use ground-based yarding systems only where physical site characteristics are suitable to avoid, minimize, or mitigate adverse effects to soil, water quality, and riparian resources.
 - ↳ Use local direction or requirements for slope, erosion potential, mass wasting potential, and other soil or site properties to determine areas suitable for ground-based yarding systems.
- Use existing roads and skid trail networks to the extent practicable.
 - ↳ Create new roads and skid trail where re-use of existing ones would exacerbate soil, water quality, and riparian resource impacts.
- Design and locate skid trails and skidding operations to minimize soil disturbance to the extent practicable.
 - ↳ Designate skid trails to the extent practicable to limit site disturbance.
 - ↳ Locate skid trails outside of the AMZ to the extent practicable.
 - ↳ Locate skid trails to avoid concentrating runoff and provide breaks in grade.
 - ↳ Limit the grade of constructed skid trails on geologically unstable, saturated, highly erodible, or easily compacted soils.
 - ↳ Avoid long runs on steep slopes.

-
- Use suitable measures during felling and skidding operations to avoid or minimize disturbance to soils and waterbodies to the extent practicable.
 - ↳ Perform skidding or yarding operations when soil conditions are such that soil compaction, displacement, and erosion would be minimized.
 - ↳ Suspend skidding or yarding operations when soil moisture levels could result in unacceptable soil damage.
 - ↳ Avoid skidding logs in or adjacent to a stream channel or other waterbody to the extent practicable.
 - ↳ Skid across streams only at designated locations.
 - ↳ Use suitable measures at skid trail crossings to avoid or minimize damage to the stream channel and streambanks.
 - ↳ Directionally fell trees to facilitate efficient removal along predetermined yarding patterns with the least number of passes and least amount of disturbed area (e.g., felling-to-the-lead).
 - ↳ Directionally fell trees away from streambanks, shorelines, and other waterbody edges.
 - ↳ Remove logs from wet meadows or AMZs using suitable techniques to minimize equipment operations in the sensitive area and minimize dragging the logs on the ground.
 - ↳ Winch or skid logs upslope, away from waterbodies.
 - ↳ Use low ground pressure equipment when practicable, particularly on equipment traveling over large portions of units with sensitive soils or site conditions.
 - Use applicable practices of BMP Veg-2 (Erosion Prevention and Control) to minimize and control erosion to the extent practicable.
 - Use suitable measures to stabilize and restore skid trails after use.
 - ↳ Reshape the surface to promote dispersed drainage.
 - ↳ Install suitable drainage features.
 - ↳ Mitigate soil compaction to improve infiltration and revegetation conditions.
 - ↳ Apply soil protective cover on disturbed areas where natural revegetation is inadequate to prevent accelerated erosion before the next growing season.
 - ↳ Use suitable measures to promote rapid revegetation.
 - ↳ Use suitable measures in compliance with local direction to prevent and control invasive species.

Veg-5. Cable and Aerial Yarding Operations

Manual or Handbook

Reference FSH 2409.15.

Objective Avoid, minimize, or mitigate adverse effects to soil, water quality, and riparian resources during cable and aerial yarding operations by minimizing site disturbance and controlling the introduction of sediment, nutrients, and chemical pollutants to waterbodies.

Explanation Cable and aerial yarding systems partially or fully suspend logs off the ground when yarding logs to the landing. They include skyline cable, helicopter, and balloon systems that typically are used in steep, erodible, and unstable areas where ground-based systems should not operate. Soil disturbance and erosion risks from these systems are primarily confined to cable corridors and landings.

Practices Develop site-specific BMP prescriptions for the following practices, as appropriate or when required, using State BMPs, Forest Service regional guidance, land management plan direction, BMP monitoring information, and professional judgment.

- Use cable or aerial yarding systems on steep slopes where ground-based equipment cannot operate without causing unacceptable ground disturbance.
 - Use local direction or requirements for slope, erosion potential, mass wasting potential, and other soil or site properties to determine areas suitable for cable or aerial yarding systems.
 - Consider slope shape, potential barriers, lift and deflection requirements, and availability of suitable landing locations when selecting cable-yarding systems.
- Identify areas requiring cable or aerial yarding during project planning and in the contract.
- Identify necessary equipment capabilities in the contract.
- Locate cable corridors to efficiently yard materials with the least soil damage.
 - Use suitable measures to minimize soil disturbance when yarding over breaks in slope.
- Fully suspend logs to the extent practicable when yarding over AMZs and streams.
- Postpone yarding operations when soil moisture levels are high if the specific type of yarding system results in unacceptable soil disturbance and erosion within cable corridors.
- Use applicable practices of BMP Veg-2 (Erosion Prevention and Control) to minimize and control erosion in cable corridors to the extent practicable.

Veg-6. Landings

Manual or Handbook

Reference FSH 2409.15.

Objective Avoid, minimize, or mitigate adverse effects to soil, water quality, and riparian resources from the construction and use of log landings.

Explanation Log landings, in general, are the site of intense activity, serving as the endpoint of yarding operations, the setup location of large equipment (such as skyline yarders), loading areas for log trucks, and fueling and maintenance locations for heavy equipment. To accommodate all this activity, landings tend to be large, and their soils generally become compacted, rutted, and disturbed much more than the rest of the project area. Thus, landings have a high probability of being a source of concentrated overland flow containing sediment and other pollutants.

Practices Develop site-specific BMP prescriptions for the following practices, as appropriate or when required, using State BMPs, Forest Service regional guidance, land management plan direction, BMP monitoring information, and professional judgment.

- Minimize the size and number of landings as practicable to accommodate safe, economical, and efficient operations.
- Locate landings to limit the potential for pollutant delivery to waterbodies.
 - Locate landings outside the AMZ and as far from waterbodies as reasonably practicable based on travel routes and environmental considerations.
 - Avoid locating landings near any type of likely flow or sediment transport conduit during storms, such as ephemeral channels and swales, where practicable.
 - Locate landings to minimize the number of required skid roads.

-
- ↳ Avoid locating landings on steep slopes or highly erodible soils.
 - ↳ Avoid placing landings where skidding across drainage bottoms is required.
 - Design roads and trail approaches to minimize overland flow entering the landing.
 - Re-use existing landings where their location is compatible with management objectives and water quality protection.
 - Use applicable practices of BMP Veg-2 (Erosion Prevention and Control) to minimize and control erosion as needed during construction and use of log landings.
 - ↳ Install and maintain suitable temporary erosion control and stabilization measures when the landing will be reused within the same year.
 - Use applicable practices of BMP Fac-6 (Hazardous Materials) and BMP Road-10 (Equipment Refueling and Servicing) when managing fuels, chemicals, or other hazardous materials on the landing.
 - Use suitable measures as needed to restore and stabilize landings after use.
 - ↳ Remove all logging machinery refuse (e.g., tires, chains, chokers, cable, and miscellaneous discarded parts) and contaminated soil to a proper disposal site.
 - ↳ Reshape the surface to promote dispersed drainage.
 - ↳ Install suitable drainage features.
 - ↳ Mitigate soil compaction to improve infiltration and revegetation conditions.
 - ↳ Apply soil protective cover on disturbed areas where natural revegetation is inadequate to prevent accelerated erosion before the next growing season.
 - ↳ Use suitable measures to promote rapid revegetation.
 - ↳ Use suitable species and establishment techniques to cover or revegetate disturbed areas in compliance with local direction and requirements per FSM 2070 and FSM 2080 for vegetation ecology and prevention and control of invasive species.

Veg-7. Winter Logging

Manual or Handbook

Reference FSH 2409.15.

Objective Avoid, minimize, or mitigate adverse effects to soil, water quality, and riparian resources from winter logging activities.

Explanation Winter logging on frozen or snow-covered ground is a common BMP in the colder regions of the country to avoid or minimize soil, watershed, riparian, and wetland impacts. Winter logging is not without risks of watershed effects. Unknowingly operating in wetland or riparian areas when the snow cover is inadequate can cause damage to soil and vegetation. Skidding or hauling on roads when the roadbed or the soil is not sufficiently frozen can cause soil compaction and rutting. Inadequate installation and maintenance of erosion controls before snowmelt and spring runoff can cause accelerated erosion and damage to roads.

Practices Develop site-specific BMP prescriptions for the following practices, as appropriate or when required, using State BMPs, Forest Service regional guidance, land management plan direction, BMP monitoring information, and professional judgment.

-
- Consider using snow-roads and winter harvesting in areas with high-water tables, sensitive riparian conditions, or other potentially significant soil erosion and compaction hazards.
 - ↳ Use snow roads for single-entry harvests or temporary roads.
 - Mark existing culvert locations before plowing, hauling, or yarding operations begin to avoid or minimize damage from plowing or logging machinery.
 - Ensure all culverts and ditches are open and functional during and after logging operations.
 - Plow any snow cover off roadways to facilitate deep-freezing of the road grade before hauling.
 - ↳ Manage hauling to avoid or minimize unacceptable damage to the road surface.
 - Use suitable measures to cross streams (see BMP Road-7 [Stream Crossings]).
 - ↳ Restore crossings to near preroad conditions to avoid or minimize ice dams when use of the snow-road is no longer needed.
 - Conduct winter logging operations when the ground is frozen or snow cover and depth is adequate to avoid or minimize unacceptable rutting or displacement of soil.
 - Suspend winter operations if ground and snow conditions change such that unacceptable soil disturbance, compaction, displacement, or erosion becomes likely.
 - Compact the snow on skid trail locations when adequate snow depths exist before felling or skidding trees.
 - Avoid locating skid trails on steep areas where frozen skid trails may be subject to soil erosion the next spring.
 - Mark AMZ boundaries and stream courses before the first snow in a manner that will be clearly visible in heavy snows.
 - Avoid leaving slash in streams or AMZs to the extent practicable.
 - Install and maintain suitable erosion control on skid trails before spring runoff (see BMP Veg-2 [Erosion Prevention and Control]).
 - ↳ Install erosion control measures during the dry season if needed.

Veg-8. Mechanical Site Treatment

Manual or Handbook

Reference None known.

Objective Avoid, minimize, or mitigate adverse effects to soil, water quality, and riparian resources by controlling the introduction of sediment, nutrients, chemical, or other pollutants to waterbodies during mechanical site treatment.

Explanation Mechanical treatments are used to remove or reduce the amount of live and dead vegetation on a site to meet management objectives, such as site preparation for reforestation, fuel treatments to reduce fire hazards, wildlife habitat improvement, recreation access, utility corridor maintenance, and other activities that require removing vegetation from specified areas on a periodic and repeated basis. Mechanical treatments include cutting and piling; chipping or mulching; roller chopping or masticating using heavy equipment; and pushing over vegetation. Disturbance from mechanical site treatments can expose and compact soils, resulting in accelerated runoff and erosion.

Practices Develop site-specific BMP prescriptions for the following practices, as appropriate or when required, using State BMPs, Forest Service regional guidance, land management plan direction, BMP monitoring information, and professional judgment.

- Evaluate multiple site factors, including soil conditions, slope, topography, and weather, to prescribe the most suitable mechanical treatment and equipment to avoid or minimize unacceptable impacts to soil while achieving treatment objectives.
 - ↳ Consider the condition of the material and the site resulting from the treatment in comparison to desired conditions, goals, and objectives for the site when analyzing treatment options (e.g., a mastication treatment will result in a very different condition than a grapple pile and burn treatment).
 - ↳ Use land management plan direction, or other local guidance, to establish residual ground cover requirements and soil disturbance limits suitable to the site to minimize erosion.
 - ↳ Consider offsite use options for the biomass material to reduce onsite treatment and disposal.
- Use applicable practices of BMP Veg-3 (Aquatic Management Zones) when conducting mechanical treatments in the AMZ.
- Use applicable practices of BMP Veg-2 (Erosion Prevention and Control) to minimize and control erosion.
 - ↳ Conduct mechanical activities when soil conditions are such that unacceptable soil disturbance, compaction, displacement, and erosion would be avoided or minimized.
 - ↳ Consider using low ground-pressure equipment, booms, or similar equipment to minimize soil disturbance.
- Operate mechanical equipment so that furrows and soil indentations are aligned on the contour.
- Scarify the soil only to the extent necessary to meet reforestation objectives.
 - ↳ Use site-preparation equipment that produces irregular surfaces.
 - ↳ Avoid or minimize damage to surface soil horizons to the extent practicable.
- Conduct machine piling of slash in such a manner to leave topsoil in place and to avoid displacing soil into piles.
- Re-establish vegetation as quickly as possible.
 - ↳ Evaluate the need for active and natural revegetation of exposed and disturbed sites.
 - ↳ Use suitable species and establishment techniques to revegetate the site in compliance with local direction and requirements per FSM 2070 and FSM 2080 for vegetation ecology and prevention and control of invasive species.

Resources for Mechanical Vegetation Management Activities

BMP Effectiveness Lynch, J.A.; Corbett, S. 1990. Evaluation of best management practices for controlling nonpoint pollution from silvicultural operations. *Journal American Water Resources Association*. 26(1): 41–52.

Rashin, E.B.; Clishe, C.J.; Loch, A.T.; Bell, J.M. 2006. Effectiveness of timber harvest practices for controlling sediment related water quality impacts. *Journal American Water Resources Association*. 42(5): 1307–1327.

General U.S. Environmental Protection Agency, Office of Water. 2005. National management measures to control nonpoint source pollution from forestry. EPA 841-B-05-001. Washington, DC. Available at <http://www.epa.gov/owow/nps/forestrygmt/>.

Planning Grant, G.E.; Lewis, S.L.; Swanson, F.J.; Cissel, J.H.; McDonnell, J.J. 2008. Effects of forest practices on peak flows and consequent channel response: a state-of-the-science report for western Oregon and Washington. Gen. Tech. Rep. PNW- 760. Portland, OR: U.S. Department of Agriculture, Forest Service, Pacific Northwest Research Station. 76 p. Available at <http://www.fs.fed.us/pnw/publications/gtrs2008.shtml>.

Riparian Areas Goodwin, C.N.; Hawkins, C.P.; Kershner, J.L. 1997. Riparian restoration in the Western United States: Overview and perspective. *Restoration Ecology*. 5(s4): 4–14. Available at <http://www.wiley.com/WileyCDA/WileyTitle/productCd-REC.html>.

Vermont Agency of Natural Resources. 2005. Riparian buffers and corridors Technical papers. Waterbury, VT: Vermont Agency of Natural Resources. 39 p. Available at <http://www.anr.state.vt.us/site/html/buff/anrbuffer2005.htm>.

Selected State Forestry

BMP Documents See Appendix B.

Water Uses Management Activities

The purpose of this set of Best Management Practices (BMPs) is to avoid, minimize, or mitigate adverse effects to soil, water quality, and riparian resources from development and operation of infrastructure to collect, impound, store, transmit, and distribute water for uses on and off National Forest System (NFS) lands. Water use infrastructure includes wells for public or private water supply or groundwater monitoring; water source developments for Forest Service uses; water diversions and conveyances for uses off of NFS lands; and dams and impoundments for water supply storage, flood control, power generation, recreation, and wildlife habitat.

States govern the allocation of water for beneficial use. State laws and programs for water allocation vary widely across the country, from riparian rights systems to administrative permits to court-adjudicated water rights systems. The Forest Service responsibility when authorizing water use infrastructure projects is to avoid or minimize damage to NFS resources in compliance with environmental laws and land management plan direction.

Six National Core BMPs are in the Water Uses Management Activities category. These BMPs are to be used in all water use projects on NFS lands to the extent allowed by State laws and regulations pertaining to water allocation. Each BMP was formulated to reflect administrative directives that guide the Forest Service's development and administration of water uses on NFS lands. BMP WatUses-1 (Water Uses Planning) is a planning BMP for water uses projects. BMP WatUses-2 (Water Wells for Production and Monitoring) provides practices for drilling, operating, and abandoning water production and monitoring wells. BMP WatUses-3 (Administrative Water Developments) provides direction for development of water sources to be used for NFS land management purposes such as stock watering, potable water at campgrounds, or fire protection. BMP WatUses-4 (Water Diversions and Conveyances) provides direction for diversion and conveyance of surface water for third-party uses on or off NFS lands. BMP WatUses-5 (Dams and Impoundments) provides direction for construction and operation of dams and impoundments for flood control, hydroelectric power generation, water supplies, and recreation on NFS lands. BMP WatUses-6 (Dam Removal) provides direction for removal of dams and impoundments to restore streams and rivers.

States will be used in the rest of this resource category to signify both States and those tribes that have received approval from the U.S. Environmental Protection Agency (EPA) for treatment as a State under the Clean Water Act (CWA).

Water Uses BMPs	
WatUses-1	Water Uses Planning
WatUses-2	Water Wells for Production and Monitoring
WatUses-3	Administrative Water Developments
WatUses-4	Water Diversions and Conveyances
WatUses-5	Dams and Impoundments
WatUses-6	Dam Removal

WatUses-1. Water Uses Planning

Manual or Handbook

Reference Forest Service Manual (FSM) 2540.

Objective Use the applicable authorization and administrative planning processes to develop measures to avoid, minimize, or mitigate adverse effects to soil, water quality, and riparian resources during construction, operation, maintenance, and restoration of water use infrastructure.

Explanation Development and operation of infrastructure for water uses involve ground disturbance for construction of the facility and changes to water levels and flow regimes in source and receiving waterbodies and aquifers during operations. During planning, site conditions are evaluated and water levels and flow needs of the aquatic ecosystem are assessed to determine site-specific measures to avoid, minimize, or mitigate adverse effects to soil, water quality, groundwater, and riparian resources.

Infrastructure for water uses may be developed on NFS lands by the Forest Service for a variety of administrative and resource management purposes. As new sites are created and existing sites are expanded or rehabilitated, potential effects of the proposed development and operation on soil, water quality, groundwater, and riparian resources are considered in the project National Environmental Policy Act (NEPA) analysis and decision. Site-specific BMP prescriptions are included in the project plan, contract, or other authorizing document as appropriate.

Infrastructure developed by others on NFS lands are administered through authorizations issued by the Forest Service to a public or private agency, group, or individual. Authorization documents include terms and conditions to protect the environment and comply with the requirements of the Federal Land Policy and Management Act of 1976 (43 U.S.C. 1752) and other laws. Control of nonpoint sources of water pollution using appropriate BMPs is included in these environmental protection requirements.

Facilities on lands withdrawn under authority of the Federal Energy Regulatory Commission (FERC) are exempt from Forest Service administrative control through the NFS permit system. When a FERC permit is issued or renewed, however, the Forest Service may provide FERC with recommended requirements and mitigation measures under which the permittee should operate to protect NFS resources. Such recommendations may include any BMPs necessary to avoid, minimize, or mitigate adverse effects to soil, water quality, and riparian resources.

Practices Develop site-specific BMP prescriptions for the following practices, as appropriate or when required, using State BMPs, Forest Service regional guidance, land management plan direction, BMP monitoring information, and professional judgment.

- Use applicable practices of BMP Plan-2 (Project Planning and Analysis) and BMP Plan-3 (Aquatic Management Zone (AMZ) Planning) when planning water use projects.
- Encourage reuse of water, to the extent practicable, to minimize withdrawals from surface water or groundwater sources.
- Determine the water quality, water quantity, flow regimes, and water levels necessary to maintain land management plan desired conditions, goals, and objectives, including applicable water quality standards for waterbodies and aquatic and groundwater-dependent ecosystems that are affected by the proposed project.
 - ┆ Specify a range of flows and levels to support desired uses and values.
- Obtain surface water (e.g., instream flow rights) and groundwater under appropriate Federal and State legal and regulatory authorities to avoid, minimize, or mitigate adverse effects to stream

processes, aquatic and riparian habitats and communities, groundwater-dependent ecosystems, and recreation and aesthetic values.

- ┆ Prioritize protection of imperiled native species.
- Evaluate water levels, flows, and water quality of the affected waterbody or aquifer to ensure that the source can provide an adequate supply and quality of water for the intended purpose(s) and avoid or minimize damage to NFS resources.
 - ┆ Consider how the collection, diversion, storage, transmission, and use of the water would directly, indirectly, and cumulatively affect streamflow, water level, channel morphology and stability, groundwater, and aquatic and riparian habitats in source and receiving waterbodies at a watershed scale(s) suitable for the project area and impacts.
 - ┆ Consider the potential impacts of current and expected environmental conditions such as climate change on precipitation type, magnitude, frequency, and duration and related effects on runoff patterns and water yield.
- Develop a strategic plan for the development of a suitable number of durable long-term water sources for Forest Service administrative and resource management uses to achieve land management plan desired conditions, goals, and objectives.
 - ┆ Obtain necessary water rights, allocations, or permits and water quality permits and certifications from applicable Federal, State, and local agencies for Forest Service administrative or resource management water uses.
- Include permit conditions at the point of diversion, withdrawal, or storage to minimize damage to water-dependent resources and values consistent with land management plan desired conditions, goals, and objectives in authorizations for new or existing water use facilities.
 - ┆ Consider the water needs for physical stream processes, water quality, aquatic biota and their habitat, riparian habitat and communities, aesthetic and recreational values, and special designations such as Federal and State wild or scenic rivers.

WatUses-2. Water Wells for Production and Monitoring

Manual or Handbook

Reference Forest Service Handbook (FSH) 7409.11, chapter 41.

Objective Avoid, minimize, or mitigate adverse effects to soil, water quality, groundwater, and riparian resources from excessive withdrawals and contamination transmitted from or by water-well and monitoring-well developments.

Explanation Construction and operation of production wells, monitoring wells, and associated facilities have the potential to alter water levels and flow paths; contaminate surface water and groundwater; expose soil to accelerated erosion; and threaten the viability of aquatic and terrestrial species dependent on local surface water and groundwater. Properly designed wells and aboveground well-casing collars minimize the risk of aquifer contamination from the well-casing, animal and human activities, and accidental or intentional placement of materials into wells. Well uses should be within sustainable levels to avoid onsite and offsite effects to groundwater levels, streamflows, and riparian-dependent resources. States regulate water well drilling, and requirements vary.

Practices Develop site-specific BMP prescriptions for the following practices, as appropriate or when required, using State BMPs, Forest Service regional guidance, land management plan direction, BMP monitoring information, and professional judgment.

-
- Locate water production wells on high or well-drained ground at a sufficient distance away from potential contamination sources to avoid or minimize contamination.
 - Locate monitoring wells according to a monitoring plan to minimize the number of wells needed to achieve monitoring objectives.
 - Use applicable practices of BMP Fac-2 (Facility Construction and Stormwater Control) to control stormwater and erosion during construction of drill pads and associated facilities for well operation.
 - Construct and complete wells consistent with applicable Federal and State regulations.
 - ┆ Use licensed well drilling contractors.
 - ┆ Use suitable measures to avoid or minimize well contamination, inter-aquifer exchange of water, floodwaters from contaminating the aquifer, and infiltration of surface water.
 - Operate wells in such a manner as to avoid excessive withdrawals, maintain suitable groundwater levels, and minimize effects to groundwater-dependent ecosystems.
 - Permanently seal abandoned wells consistent with applicable Federal, State, and local regulations and requirements.
 - ┆ Use licensed well drilling contractors.
 - ┆ Use suitable measures to avoid or minimize contaminating the aquifer or surface waters and interaquifer exchange and mixing of water.
 - ┆ Use suitable measures to preserve hydrogeologic conditions of the ground and aquifers.

WatUses-3. Administrative Water Developments

Manual or Handbook

Reference FSM 2540.

Objective Avoid, minimize, or mitigate adverse effects to soil, water quality, and riparian resources when developing and operating water sources for Forest Service administrative and resource management purposes.

Explanation Water source developments are needed to supply water for a variety of Forest Service administrative and resource management purposes, including road construction and maintenance, dust control, fire control, recreation facilities, and livestock and wildlife watering. Water sources may be developed and used permanently or temporarily based on the needs of the management activity. Permanent water source development should be aimed toward the construction of a limited number of durable, long-term water sources. Piped and impounded diversions such as wells, spring developments, hydrants, supply lines, drains, ponds, cisterns, tanks, and dams are examples of permanent structures. Temporary water sources may be needed to support one-time or emergency projects such as watershed restoration and fire suppression.

Water source developments include the access road, turnaround, and drafting area. Soil, water quality, and riparian resources may be impacted by permanent or temporary water source construction and use. Potential impacts include erosion and sediment delivery to waterbodies; stream-bank and streambed alterations; contamination from equipment leaks or spills; changes in water temperatures; reduction in streamflows; loss of riparian vegetation; direct injury to aquatic species from pumping equipment; and transportation of eggs, larvae, and adults out of the aquatic system. Proper location and design of water sources or upgrading existing water source facilities can avoid, minimize, or mitigate adverse these impacts.

Practices Develop site-specific BMP prescriptions for the following practices, as appropriate or when required, using State BMPs, Forest Service regional guidance, land management plan direction, BMP monitoring information, and professional judgment.

- Design, construct, maintain, and monitor permanent water sources in compliance with Federal, State, and local requirements.

Drafting From Streams or Standing Waterbodies

- Locate water source developments, including access roads, in such a manner as to avoid or minimize disturbance to the riparian area and streambanks and erosion and sedimentation to the extent practicable.
 - ┆ Draft from existing roads and bridges to the extent practicable to avoid creating new access roads.
 - ┆ Use existing hardened facilities, such as boat launches and campground access roads, for emergency or other short-term uses rather than native surface areas prone to erosion.
 - ┆ Locate facilities to minimize potential damage from streamflows.
 - ┆ Locate permanent storage tanks, dry hydrants, and standpipes outside of the AMZ to the extent practicable.
 - ┆ Locate off-channel ponds in areas where they will not be inundated with sediment at high flows.
 - ┆ Locate ponds or storage tanks as close to the major water use as practicable when water must be conveyed for use at a distance from the source.
- Design source developments, including access roads, in such a manner as to avoid or minimize disturbance to the riparian area and streambanks and to avoid or minimize erosion, sediment, and other pollutants to the extent practicable.
 - ┆ Design permanent facilities to maintain long-term stream function and processes.
 - ┆ Limit the size of the facility development footprint (area of bare soil with reduced infiltration capacity) to the minimum necessary for efficient operations to the extent practicable.
 - ┆ Design facility to minimize hydrologic connectivity with the waterbody to the extent practicable by providing a suitable vegetated filter strip, and designing access road slope and length, or using other suitable measures, to direct flow away from the waterbody (see BMP Road-2 [Road Location and Design]).
 - ┆ Modify vehicle access and turnaround areas to reduce the size of the facility within the most sensitive areas of the AMZ.
 - ┆ Install hardened facilities where an adequate streamflow exists throughout the drafting season.
- Construct water source developments, including access roads, in such a manner as to avoid or minimize disturbance to the riparian area and streambanks and erosion, sediment, and other pollutants to the extent practicable.
 - ┆ Use applicable practices of BMP Road-3 (Road Construction and Maintenance) when constructing access roads to control stormwater runoff and erosion.
 - ┆ Use applicable practices of BMP AqEco-2 (Operations in Aquatic Ecosystems) when working in or near waterbodies.
 - ┆ Use applicable practices of BMP AqEco-3 (Ponds and Wetlands) when constructing off-channel ponds.

-
- ┆ Use suitable measures to minimize streambank alteration and excavation activity within the streambed to the extent practicable while providing an adequate area for water drafting.
 - Conduct operations at water source developments in such a manner as to avoid, minimize, or mitigate adverse effects to aquatic species and habitats from water drafting.
 - ┆ Obtain and maintain water rights for administrative use and resource needs.
 - ┆ Avoid or minimize effects to the waterbody or aquifer by withdrawing only the minimum amount of water sufficient to achieve administrative or resource management needs.
 - ┆ Establish limits or guidelines for water withdrawals from a lake, pond, or reservoir source based on evaluation of storage capacity and recharge and potential impacts to habitat from drafting and drawdown.
 - ┆ Establish limits or guidelines for absolute pumping rates and pumping rate in relation to streamflow.
 - ┆ Limit drafting operations to daylight hours to avoid attracting fish to the drafting pool.
 - ┆ Use suitable screening devices to avoid or minimize transport of aquatic organisms out of the source waterbody.
 - ┆ Use suitable measures to avoid or minimize contamination from spills or leaks.
 - ┆ Use applicable practices of BMP Fac-6 (Hazardous Materials) to manage contamination from spills or leaks.
 - Maintain sources and facilities such that diversion, drainage, and erosion control features are functional.
 - Use applicable practices of BMP Fac-10 (Facility Site Reclamation) to reclaim water use sites when no longer needed.
 - ┆ Repair or restore temporary sources to their pre-use condition to the extent practicable before project completion.
 - ┆ Apply suitable seasonal protection measures to temporary sources if use extends past a single season.

Spring Developments

- Locate the water trough, tank, or pond at a suitable distance from the spring to avoid or minimize adverse effects to the spring and wetland vegetation from livestock trampling or vehicle access.
- Locate the spring box to allow water to flow by gravity from the spring to the spring box to eliminate disturbance from pumps and auxiliary equipment.
- Design the collection system to avoid, minimize, or mitigate adverse effects to the spring development and downstream waters from excessive water withdrawal, freezing, flooding, sedimentation, contamination, vehicular traffic, and livestock as needed.
 - ┆ Collect no more water than is sufficient to meet the intended purpose of the spring development.
 - ┆ Ensure that enough water remains in the spring to support the source groundwater-dependent ecosystem and downstream aquatic ecosystems.
 - ┆ Avoid or minimize sediment or bacteria from entering the water supply system.
 - ┆ Trap and remove sediment that does enter the system.
 - ┆ Intercept the spring flow below the ground surface upslope of where the water surfaces.

-
- ↳ Size the spring box sufficient to store expected volume of sediment generated between maintenance intervals and enough water for efficient operation of the system, and to provide access for maintenance and cleaning.
 - ↳ Avoid or minimize backing up of spring flow by providing overflow relief sized to carry the maximum flow expected from the spring during periods of wet weather.
 - ↳ Use suitable measures to avoid or minimize erosion at the overflow outlet.
 - ↳ Maintain fish and wildlife access to water released below the spring development to the extent practicable.
 - Construct the spring development in such a manner to avoid or minimize erosion, damage to vegetation, and contamination.
 - ↳ Use applicable practices from BMP AqEco-2 (Operations in Aquatic Ecosystems) when working in springs.
 - ↳ Divert all surface water away from the spring to the extent practicable to avoid or minimize flooding near the spring development.
 - ↳ Use suitable species and establishment techniques for wet conditions to cover or revegetate disturbed areas near springs in compliance with local direction and requirements per FSM 2070 and FSM 2080 for vegetation ecology and prevention and control of invasive species.
 - Operate and maintain the spring development and associated water storage in such a manner as to provide water of sufficient quantity and quality for the intended uses and avoid or minimize failure of infrastructure causing concentrated runoff and erosion.
 - ↳ Disinfect the spring water as needed to maintain water quality sufficient for intended uses in such a manner as to avoid or minimize adverse effects to the spring source.
 - ↳ Use suitable measures to manage uses such as livestock grazing and vehicle traffic around the spring development to avoid or minimize erosion and sedimentation affecting the spring.
 - ↳ Avoid heavy vehicle traffic over the uphill water-bearing layer to avoid or minimize compaction that may reduce water flow.
 - ↳ Use suitable measures to avoid or minimize overflow of water trough, tank, or pond.
 - ↳ Periodically monitor the spring development and promptly take corrective action for sediment buildup in the spring box, clogging of outlet and overflow pipes, diversion of surface water from the collection area and spring box, erosion from overflow pipes, and damage from animals.
 - Use applicable practices of BMP Fac-10 (Facility Site Reclamation) to reclaim spring development sites when no longer needed.

WatUses-4. Water Diversions and Conveyances

Manual or Handbook

Reference FSM 2729 and FSM 7510.

Objective Avoid, minimize, or mitigate adverse effects to soil, water quality, and riparian resources from construction, operation, and maintenance of water diversion and conveyance structures.

Explanation Water may be diverted from waterbodies on NFS lands by third parties and delivered to sites on or off of NFS lands for a variety of purposes, including agriculture, mining, domestic water supply, hydroelectric power generation, or other uses. Water delivery systems consist of a diversion structure

and some type of conduit. Conduits can be ditches, open canals, flumes, tunnels, pipelines, or even natural channels. Structures to regulate flow, dispose of excess water, or trap sediment and debris may also be part of the water delivery system.

The construction, operation, and maintenance of water diversions and conveyances can have adverse direct and indirect effects on soil, water quality, and riparian resources. The construction or presence of access routes, head gates, storage tanks, reservoirs, and other facilities can alter water quality, water yield, runoff regimes, natural channel geomorphic processes, and fish and wildlife habitats. Altered flow regimes can result in elevated water temperatures, proliferating algal blooms, and invasive aquatic flora and fauna. Water yield and runoff changes can change sediment dynamics and affect channel shape and substrate composition. Regular maintenance of diversions and conveyances can result in contamination from pesticide applications, vegetation damage, and continued soil disturbance leading to increased erosion; however, lack of regular maintenance can increase the potential for even greater effects from failures of ditches and diversions.

Practices Develop site-specific BMP prescriptions for the following practices, as appropriate or when required, using State BMPs, Forest Service regional guidance, land management plan direction, BMP monitoring information, and professional judgment.

- Locate water conveyance structures in stable areas where they are not susceptible to damage from side drainage flooding.
- Design diversion and conveyance structures to efficiently capture and carry design flows in such a manner as to avoid or minimize erosion of streambanks, ditches, and adjacent areas.
 - ┆ Design intake and outflow structures to minimize streambank and streambed damage and minimize disruption of desired aquatic organism movement.
 - ┆ Design water conveyance structure to have sufficient capacity to carry the design volume of water with appropriate freeboard to avoid or minimize damage or overtopping.
 - ┆ Consider velocity of the water, horizontal and vertical alignment of the ditch or canal, amount of stormwater that may be intercepted, and change in water surface elevation at any control structures when determining appropriate freeboard needed.
 - ┆ Use suitable measures in the design to control velocity and slope to avoid or minimize erosion of the ditch.
 - ┆ Use suitable measures in the design to minimize water loss to evaporation and leakage.
 - ┆ Mitigate water imports and water disposal (including reservoir releases) so that the extent of stable banks, channel pattern, profile and dimensions are maintained in each receiving stream reach to meet applicable instream water quality standards.
- Construct diversion and conveyance structures to perform as intended in the most efficient manner and in such a way as to avoid, minimize, or mitigate adverse effects to soil, water quality, and riparian resources.
 - ┆ Use applicable practices of BMP AqEco-2 (Operations in Aquatic Ecosystems) when constructing diversion structures in waterbodies.
 - ┆ Use applicable practices of BMP Fac-2 (Facility Construction and Stormwater Control) to control stormwater and erosion when constructing diversion or conveyance structures.
 - ┆ Use suitable measures to stabilize the banks of the diversion channel or conveyance structure to avoid or minimize resulting erosion and instream sedimentation.

-
- ↳ Construct or install structures such as inlets, outlets, turnouts, checks, and crossings in such a manner as to maintain the capacity or freeboard of the ditch and the effectiveness of any lining or other channel stabilization measure.
 - ↳ Use suitable measures at outlets to avoid or minimize erosion downstream of the structure when design flows are released.
 - ↳ Use suitable measures on inlet structures to avoid or minimize debris entering the water conveyance structure.
 - Operate diversion structures in such a manner as to leave desired or required flows and water levels in the source waterbody as determined in project planning (see BMP WatUses-1 [Water Uses Planning]).
 - Operate and maintain diversion and conveyance structures in such a manner as to avoid, minimize, or mitigate adverse effects to soil, water quality, and riparian resources from failures.
 - ↳ Limit operation of the diversion and conveyances to the established period of use.
 - ↳ Regularly inspect diversion and conveyance structures at suitable intervals to identify maintenance needs and situations that could lead to future overtopping or failures.
 - ↳ Do not flush or otherwise move sediment from behind diversion structures downstream.
 - ↳ Deposit and stabilize sediment removed from behind a diversion structure in a suitable designated upland site.
 - ↳ Maintain suitable vegetative cover near canal and ditch banks to stabilize bare soils and minimize erosion.
 - ↳ Harden or reroute breach-prone segments of ditches to minimize potential for failure and erosion of fill slopes.
 - ↳ Maintain and operate water conveyance structures to carry their design volumes of water with appropriate freeboard.
 - ↳ Keep water conveyance structures clear of vegetation, debris and other obstructions to minimize potential for failures.
 - ↳ Use applicable Chemical Use Activities BMPs when using chemicals to treat vegetation as a part of water conveyance structure maintenance.
 - Use applicable measures of BMP AqEco-4 (Stream Channels and Shorelines) and BMP Fac-10 (Facility Site Reclamation) to restore the stream channel and surrounding areas after the diversion or conveyance structure is no longer needed.

WatUses-5. Dams and Impoundments

Manual or Handbook

Reference FSM 7500, FSH 7509.11, FSM 2770, and FSH 2709.15.

Objective Avoid, minimize, or mitigate adverse effects to soil, water quality, and riparian resources from construction, operation, and maintenance of dams and impoundments.

Explanation The physical presence and operation of dams can result in changes in water quality, water quantity, sediment routing, channel morphology, stability, and habitat. Water quality can be impacted by changes in erosion, sedimentation, temperature, dissolved gases, and water chemistry. Resulting biologic and habitat impacts that may result include loss of habitat for existing or desirable fish.

amphibian, and invertebrate species; shift from cold water to warm water species (or conversely, shift from warm-water to cold-water species); blockage of fish passage; or loss of spawning or other necessary habitat.

The operation of dams can result in diverse impacts on water quality. The area and depth of the impoundment, as well as the timing and volume of releases, determines the extent and complexity of the upstream and downstream impacts. For example, impacts of low-head dams with small impounded areas will involve sedimentation and fish passage; larger storage dams may have those issues as well as temperature, flow regulation, and water quality considerations. Impacts from dams are different above (upstream) and below (downstream) the dam. Upstream impacts occur primarily in the impoundment or reservoir created by the presence and operation of the dam. Downstream impacts result from changes in sediment load, water quantity, chemistry and the timing and magnitude of water releases.

Federal laws provide the Forest Service the authority to require or recommend BMPs to avoid, minimize, or mitigate adverse effects to soil, water quality, riparian and other resources from new or existing hydroelectric projects and associated infrastructure on or adjacent to NFS lands. The specific regulations and procedures that apply vary depending on project-specific circumstances (see FSM 2770 and FSH 2709.15).

- Practices** Develop site-specific BMP prescriptions for the following practices, as appropriate or when required, using State BMPs, Forest Service regional guidance, land management plan direction, BMP monitoring information, and professional judgment.
- Select a design and location such that the benefits of the dam are maximized and the disturbances to the environment or hazards to downstream inhabitants are minimized.
 - ┆ Implement applicable practices of BMP AqEco-3 (Ponds and Wetlands) to locate and design dams and impoundments.
 - ┆ Complete a geotechnical review of the dam site using established protocols for stability issues.
 - Use applicable practices of BMP AqEco-2 (Operations in Aquatic Ecosystems) when working in or near waterbodies to construct dams and impoundments.
 - Use applicable practices of BMP Fac-2 (Facility Construction and Stormwater Control) to control stormwater and erosion when constructing dams and impoundments.
 - Operate and maintain dams and impoundments in such a manner as to avoid, minimize, or mitigate adverse impacts to soil, water quality, and riparian resources.
 - ┆ Work with dam operators, and Federal and State regulatory agencies, to ensure that water chemistry: temperature; dissolved oxygen; nutrient levels; and hydrologic conditions, including the timing, duration and magnitude of flows, meet land management plan desired conditions, goals, and objectives (see BMP WatUses-1 [Water Uses Planning]).
 - Decommission dams and impoundments that are no longer needed for mission purposes (see BMP WatUses-6 [Dam Removal]).

WatUses-6. Dam Removal

Manual or Handbook

Reference FSM 7500 and FSH 7509.11.

Objective Avoid, minimize, or mitigate adverse effects to soil, water quality, and riparian resources during and after removal of dams.

Explanation Many existing dams no longer serve their originally intended purposes or are in varying stages of disrepair and in need of significant repair and maintenance to meet modern dam safety standards. Removal of outdated dams, where the negative impacts outweigh their benefits, is a critical mechanism in achieving restoration of natural river ecology, re-establishing river continuity, and maintaining public safety.

The most important positive outcomes of dam removal are the reconnection of river reaches so that they can operate as an integrated system and the increased accessibility to upstream habitat and spawning areas for migratory and anadromous fish. Dam removal can cause short-term impacts to the river environment from released water and sediment and exposure of previously inundated land to achieve long-term desired conditions. Careful planning can limit the effects of released sediment and toxic pollutants on aquatic life, prevent extensive erosion in the restored stream channel, and limit the potential intrusion of exotic plant species in the former impoundment.

Restoring a river by removing a dam often implies that the physical and biological components will return to the same level that existed before the dam was built. Dam removal can restore some, but not all, of the characteristics of the predam river, however. The removal of a dam has the effect of reversing some undesirable changes subject to the limits imposed by many other human influences in the watershed. Productive, useful ecosystems can result from dam removal, but predictions of outcomes are sometimes difficult because of the many interrelated changes in physical and biological systems caused by placement of the dam and other physical stresses on the river. Dam removal often results in the replacement of one aquatic community with another that is partly natural and partly artificial. Reservoirs create wetland areas in some cases; the removal of a dam and draining of a reservoir may create some wetlands downstream but at the expense of some wetlands upstream. The ultimate goal for a dam removal project is to restore the channel and its biological function to the best long-term sustainable state possible to achieve desired conditions within the context of other community issues and location within the watershed.

Practices Develop site-specific BMP prescriptions for the following practices, as appropriate or when required, using State BMPs, Forest Service regional guidance, land management plan direction, BMP monitoring information, and professional judgment.

Planning

- Use applicable practices of BMP AqEco-1 (Aquatic Ecosystem Improvement and Restoration Planning) when planning dam decommissioning or removal projects.
- Evaluate system hydrology and hydraulics to assess how dam removal would affect aquatic species passage, potential flood impacts at various flows, and potential impacts to surrounding infrastructure.
- Develop a sediment management plan (e.g., natural erosion, dredging, stabilization in place, relocation on or off site, or a combination of methods) that best suits sediment quality, quantity, and physical characteristics, as well as the sensitivity of downstream reaches and the river's ability to transport sediment.

-
- ↳ Quantitatively determine sediment volume and physical parameters, including grain size distribution, density, shear strength, cohesion, stratification, natural armoring potential, organic content, and moisture content.
 - ↳ Evaluate potential for contaminants trapped behind the dam by considering current and past upstream land uses, such as industrial activity and road density, and by adequately sampling and analyzing sediments to determine the contamination level, if any, and gradation and distribution.
 - ↳ Estimate sediment transport to address fate of released sediment and potential contaminants.
 - ↳ Evaluate potential disposal sites for long-term viability and stability of relocated sediments.
 - Identify the various aquatic and aquatic-dependent species that live in the river or on the floodplain and their life histories to determine protection strategies, including timing of dam removal, sediment management, species relocation, and monitoring during construction.
 - Evaluate floodplain and instream infrastructure to determine whether bridges, culverts, utility pipes, or other infrastructure might be affected, particularly by the drop of water level in the impoundment.
 - Develop a channel and vegetation restoration plan (see BMP AqEco-4 [Stream Channels and Shorelines] and BMP Fac-10 [Facility Site Reclamation]).
 - ↳ Evaluate the need for active and natural channel and bank reconstruction.
 - ↳ Evaluate the need for active and natural revegetation of exposed and disturbed sites.
 - Determine necessary Federal, State, and local permits needed for dam removal.

Construction

- Use applicable practices of BMP AqEco-2 (Operations in Aquatic Ecosystems) when removing dams.
- Remove or otherwise mitigate the sediment stored behind the impoundment before dismantling the structure.
- Drain the impoundment before removing structures to avoid downstream flooding and channel erosion.
 - ↳ Drain the impoundment slowly to minimize release of sediment downstream, allow bed of impoundment and stream to drain and stabilize, and avoid a sudden release of water that could unnecessarily damage downstream infrastructure or habitat.
 - ↳ Consider drawing down the impoundment during a time when exposed sediments would have an opportunity to stabilize and revegetate before structural removal of the dam.
- Demolish the structure in an efficient manner that avoids or minimizes adverse environmental effects to the extent practicable.
 - ↳ Remove entire vertical extent of the dam structure and as much of the lateral extent as practicable so as to not impinge on streamflow.
 - ↳ Consider phasing a project to minimize short-term impacts on the environment, beginning with out-of-channel work early in the phasing to accelerate and facilitate the removal process.
- Stabilize or relocate affected floodplain and instream infrastructure as needed to avoid, minimize, or mitigate adverse effects.

Restoration

- Use applicable practices of BMP AqEco-4 (Stream Channels and Shorelines) to restore streams when dams are removed.
- Use applicable practices of BMP Fac-10 (Facility Site Reclamation) to reclaim dam and associated infrastructure sites, such as temporary access roads, landings, and work areas, when dams are decommissioned.
- Simulate natural portions of surrounding stream or other nearby habitat to restore habitat more effectively.

Resources for Water Uses Management Activities

- Dams** U.S. Department of Agriculture (USDA), Natural Resources Conservation Service (NRCS). National conservation practice standards—348 dam diversion, 402 dam. Available at <http://www.nrcs.usda.gov/technical/standards/nhcp.html>.
- Dam Removal** Hoffert-Hay, D. 2008. Small dam removal in Oregon—A guide for project managers. Salem, OR: Oregon Watershed Enhancement Board. 70 p. Available at <http://www.oregon.gov/OWEB/docs/pubs/SmallDamRemovalGuide.pdf?ga=t>.
- Massachusetts Executive Office of Energy and Environmental Affairs. 2007. Dam removal in Massachusetts, a basic guide for project proponents Boston, MA. 32 p. Available at http://www.ma.gov/envir/water/publications/eea_dam_removal_guidance.pdf.
- Groundwater** Glasser, S.; Gauthier-Warinner, J.; Gurrieri, J.; Keely, J.; and others. 2007. Technical guide to managing groundwater resources. FS-881. Washington, DC: USDA Forest Service, Minerals and Geology Management. 281 p. Available at <http://www.fs.fed.us/publications/>.
- Hydrologic Modification** U.S. Environmental Protection Agency, Office of Water. 2007. National management measures to control nonpoint source pollution from hydromodification. EPA-841-B-07-002. Washington, DC. 287 p. Available at <http://www.epa.gov/owow/nps/hydromod/index.htm>.
- Ponds** USDA NRCS. National conservation practice standards—378 pond. Available at <http://www.nrcs.usda.gov/technical/standards/nhcp.html>.
- Spring Developments** Jennings, G.D. 1996. Protecting water supply springs. Pub. No. AG 473-15. Raleigh, NC: North Carolina State University, Cooperative Extension Service. Available at <http://www.ces.ncsu.edu/Publications/environment.php>.
- USDA NRCS. National conservation practice standards—574 spring development. Available at <http://www.nrcs.usda.gov/technical/standards/nhcp.html>.
- Water Sources** Napper, C. 2006. Water-source toolkit. 0625 1806. San Dimas, CA: USDA Forest Service, Technology and Development Program. 74 p. Available at http://www.fs.fed.us/eng/pubs/pdf/WaterToolkit/lo_res.shtml.
- Wells** USDA NRCS. National conservation practice standards—353 monitoring well, 642 water well, 351 well decommissioning. Available at <http://www.nrcs.usda.gov/technical/standards/nhcp.html>.

Glossary

adverse effects to soil, water quality, and riparian resources: Direct, indirect, and cumulative impacts to soil quality, surface water, and groundwater resources and riparian structure, function, and processes that prevent achievement of land management plan desired conditions, goals, and objectives for water resources; attainment of applicable Federal, State, or local water quality standards; or other water quality related requirements.

aquatic ecosystem: The stream channel, lake, or estuary bed, water, and biotic communities and the habitat features that occur therein (Forest Service Manual [FSM] 2526.05).

Aquatic Management Zone (AMZ): An administratively designated zone adjacent to stream channels and other waterbodies. The AMZ is delineated for applying special management controls aimed at maintaining and improving water quality or other water- and riparian-dependent values, including groundwater-dependent ecosystems. The width of the AMZ is determined based on site-specific factors and local requirements. AMZ delineation may encompass the floodplain and riparian areas when present. AMZ designation can have synergistic benefits to other resources, such as maintaining and improving aquatic and riparian area-dependent resources, visual and aesthetic quality, wildlife habitat, and recreation opportunities. A variety of names for the AMZ concept are used in the States and Forest Service regions: Water Influence Zone (WIZ), Rocky Mountain Region 2 (R2); Stream Environment Zones, Pacific Southwest Region (R5); Riparian Conservation Areas, R5; Riparian Reserves, R5 and Pacific Northwest Region (R6); Riparian Habitat Conservation Areas, R5 and R6; Streamside Management Unit (SMU), R6; Riparian Corridor, Southern Region (R8); Riparian Management Corridor (RMC), Eastern Region (R9); and Riparian Management Area, Alaska Region (R10). For purposes of the National Core BMPs, these areas will be referred to as AMZs.

bankfull or bankfull discharge: The bankfull stage corresponds to the discharge at which channel maintenance is the most effective; that is, the discharge at which moving sediment, forming or removing bars, forming or changing bends and meanders, and generally doing work results in the average morphologic characteristics of channels. Bankfull discharge is associated with a momentary maximum flow that, on the average, has a recurrence interval of 1.5 years as determined using a flood frequency analysis. (Dunne and Leopold 1978). In stable rivers, bankfull is reached when the water cannot be contained within its banks and flooding begins. In entrenched streams, bankfull width is restricted, and more difficult to determine, but the top of depositional features is typically bankfull. On aggrading streams, the bankfull discharge is no longer contained within the banks during a bankfull event, often causing excessive flooding. A stream's bankfull discharge may increase or decrease with hydrologic modifications, changes in impervious land surfaces, or vegetative cover types that alter the rates of water movement through the watershed (Rosgen 1996).

beneficial use (designated use): Use specified in water quality standards for each waterbody or segment whether or not it is being attained. Types of uses include public water supplies; protection and propagation of fish, shellfish, and wildlife; recreation; agriculture; industry; navigation; marinas; groundwater recharge; aquifer protection; and hydroelectric power (EPA 2007).

Best Management Practices (BMPs) for water quality: Methods, measures, or practices selected by an agency to meet its nonpoint source control needs. BMPs include but are not limited to structural and nonstructural controls and operation and maintenance procedures. BMPs can be applied before, during, and after pollution-producing activities to reduce or eliminate the introduction of pollutants into receiving waters (36 CFR 219.19).

buffer zone: (See Aquatic Management Zone.) (1) A protective, neutral area between distinct environments. (2) An area that acts to minimize the impact of pollutants on the environment or public welfare.

Burned Area Emergency Response (BAER) Program: A program initiated after a wildfire to determine the need for and to prescribe and implement emergency treatments to minimize threats to life or property or to stabilize and avoid or minimize unacceptable degradation to natural and cultural resources resulting from the effects of the wildfire. Such treatments are identified in an approved BAER report and funded under the BAER funding authority (FSM 2523).

chain of custody: A legal term that refers to the ability to guarantee the identity and integrity of the sample (or data) from collection through reporting of the test results. It is a process used to maintain and document the chronological history of the sample (or data). Chain of custody documents should include the name or initials of the person collecting the sample (or data), each person or entity subsequently having custody of it, dates the items were collected or transferred, the collection location, a brief description of the item, and a sample identification number.

Clean Water Act (CWA) 401 Certification: Certification by a State that a permit or license issued by the Federal Government meets applicable State water quality and pollution control requirements. Under section 401(a) (1) of the CWA, Federal agencies may not issue permits for activities that “may result in any discharge into navigable waters” until the State or tribe where the discharge would originate has granted or waived section 401 certification.

CWA 402 Permit: (See National Pollutant Discharge Elimination System.) Permit issued by a State or the U.S. Environmental Protection Agency that authorizes point source discharges to waters of the United States, including certain stormwater discharges from development, industrial, or construction activities (33 U.S.C. § 1342) (see Stormwater Permit). These permits often regulate the amount, timing, and composition of discharges.

CWA 404 Permit: Permit issued by the U.S. Army Corps of Engineers to regulate the discharge of dredge and fill materials to waters of the United States, including wetlands (33 U.S.C. § 1344).

cumulative watershed effects (CWE): Cumulative watershed effects (CWE) are a change in watershed condition or water quality caused by the accumulation and interaction of multiple individual impacts of land and resource management activities within a watershed over time and space. CWE may occur at locations far distances away from the sites of actual disturbance and later in time after the disturbance has occurred.

effectiveness monitoring: Monitoring to evaluate whether the specified BMPs had the desired effect (MacDonald et al. 1991).

ephemeral stream: A stream that flows only in direct response to precipitation in the immediate locality (watershed or catchment basin), and whose channel is at all times above the zone of saturation (Briggs 1996).

fen: Ancient wetland ecosystem dependent on nutrient-rich local or regional groundwater flow systems maintaining perennial soil saturation and supporting continuous organic soil (i.e., peat) accumulation (Bedford and Godwin 2003, Chimner et al. 2010, Clymo 1983, Cooper and Andrus 1994, Gorham 1953). Groundwater controls fen type, distribution, plant community composition, pH, water chemistry, and microtopography.

floodplain: The lowland and relatively flat areas adjoining inland streams and standing bodies of water and coastal waters, including debris cones and flood-prone areas of offshore islands, including at a minimum, that area subject to a 1-percent chance of flooding in any given year (FSM 2527.05).

ground cover: Material on the soil surface that impedes raindrop impact and overland flow of water. Ground cover consists of all living and dead herbaceous and woody materials in contact with the ground and all rocks greater than 0.75 inches in diameter.

groundwater-dependent ecosystem: Community of plants, animals, and other organisms whose extent and life processes depend on groundwater. Examples include many wetlands, groundwater-fed lakes and streams, cave and karst systems, aquifer systems, springs, and seeps (USDA Forest Service 2007).

implementation monitoring: Monitoring to evaluate whether BMPs were carried out as planned and specified in the environmental assessment, environmental impact statement, other planning document, permit, or contract (MacDonald et al. 1991).

inner gorge: A geomorphic feature that consists of the area of channel side slope situated immediately adjacent to the stream channel and below the first break in slope above the stream channel. Debris sliding and avalanching are the dominant mass wasting processes associated with the inner gorge (USDA Forest Service 2000).

intermittent stream: A stream or reach of stream channel that flows, in its natural condition, only during certain times of the year or in several years. Characterized by interspersed, permanent surface water areas containing aquatic flora and fauna adapted to the relatively harsh environmental conditions found in these types of environments (Briggs 1996).

lake: An inland body of standing water, perennial or intermittent, that occupies a depression in the Earth's surface and is too deep to permit vegetation to take root completely across the expanse of water.

land management plan: An individual planning document adopted under the National Forest Management Act and 36 CFR 219 that provides direction for management of a Forest Service administrative unit.

low impact development: A comprehensive stormwater management and site design technique to create a hydrologically functional site that mimics predevelopment conditions by using design techniques that infiltrate, filter, evaporate, and store runoff close to its source.

meadow: Low-level grassland near a stream, lake, or other waterbody.

municipal supply watershed: A watershed that serves a public water system as defined in the Safe Drinking Water Act of 1974, as amended (42 U.S.C. §§ 300f, et seq.), or as defined in State safe drinking water statutes or regulations (FSM 2542.05).

National Core Best Management Practices (BMPs): The nationally standardized set of general, nonprescriptive BMPs for the broad range of activities that occur on National Forest System lands as specified in the National Core BMP Technical Guide (FS-990a). The National Core BMPs require development of site-specific BMP prescriptions based on site conditions and local and regional requirements to achieve compliance with established State, tribal, and national water quality goals. (FSM 2532.05).

National Core BMPs Monitoring Protocols: The nationally standardized set of procedures for monitoring the implementation and effectiveness of the National Core BMPs as specified in the National Core BMP Monitoring Technical Guide (FS-990b) (FSM 2532.05).

National Pollutant Discharge Elimination System (NPDES): (See CWA 402 Permit.) The system for regulating the point source discharge of pollutants to waters of the United States through the issuance of permits by State water quality regulatory authorities or EPA. Section 402 of the CWA established this system.

navigable waters: Waters of the United States, including the territorial seas (CWA section 502[7]).

nonpoint source pollution: Any source of water pollution that does not meet the legal definition of “point source” in Section 502(14) of the Clean Water Act. Nonpoint sources of water pollution generally originate at indefinable or diffuse sources, and do not discharge at specific locations (FSM 2532.05).

perennial stream: A stream or reach of a channel that flows continuously or nearly so throughout the year and whose upper surface is generally lower than the top of the zone of saturation in areas adjacent to the stream (Briggs 1996).

pesticide: A general term applied to a variety of chemical pest controls, including insecticides for insects, herbicides for plants, fungicides for fungi, and rodenticides for rodents.

point source: Any discernible, confined, and discrete conveyance, such as pipes, ditches, or channels, from which pollutants are or may be discharged (CWA section 502(14); 40 CFR 122.2).

pollutant: Dredged spoil; solid waste; incinerator residue; filter backwash; sewage; garbage; sewage sludge; munitions; chemical wastes; biological materials; radioactive materials (except those regulated under the Atomic Energy Act of 1954, as amended [42 U.S.C. 2001 *et seq.*]); heat, wrecked, or discarded equipment; rock, sand, and cellar dirt; and industrial, municipal, and agricultural waste discharged into water (CWA section 502[6], 40 CFR 122.2).

pollution: The manmade or man-induced alteration of the chemical, physical, biological, or radiological integrity of water (CWA section 502[19]; 40 CFR 130.2 [c]).

pond: An inland body of standing water, perennial or intermittent, that occupies a depression in the Earth’s surface and is shallow enough to permit vegetation to take root completely across the expanse of water. A pond may be natural or manmade.

practicable: Available and capable of being done after taking into consideration cost, existing technology, and logistics in light of overall project purposes (40 CFR 230.3). Resource objectives should also be considered when determining practicable alternatives to meet a project’s overall purposes.

practice: The recommended means for achieving the Best Management Practice (BMP) objective. Not all recommended practices will be applicable in all settings; other practices may not be listed in the BMP that would work as well, or better, to meet the BMP objective in a given situation. State or local rules or regulations may require some recommended practices in some locations. The practices are written in general, nonprescriptive terms. State BMPs, regional Forest Service guidance, land management plan standards and guidelines, monitoring results, and professional judgment are used to develop site-specific BMP prescriptions to apply the recommended practices on the ground.

reclamation: Returning disturbed land to as near to its predisturbed condition as is reasonably practical.

reference condition: The set of selected measurements and conditions used as representative of the natural potential condition of a stream or waterbody. The selected measurements and conditions describe a minimally impaired watershed or reach characteristic of a stream type in an ecoregion. Minimally impaired sites are those with the least anthropogenic influences and represent the best range of conditions that can be achieved by similar streams within an ecoregion. Reference conditions can be established using a combination of methods: a single site or multiple reference sites; historical data; simulation models; and expert opinion or professional judgment (EPA 1996).

rehabilitation: A putting back into good condition, re-establishing on a firm, sound basis.

restoration: A putting or bringing back into a former, normal, or unimpaired state or condition.

riparian area: A transition area between the aquatic ecosystem and the adjacent terrestrial ecosystem that is identified by soil characteristics or distinctive vegetation communities that require free or unbound water.

site-specific BMP prescriptions: Site-specific techniques implemented on the ground to control nonpoint source pollution. Site-specific BMP prescriptions are determined during the project planning process and described in decision documents to apply the National Core BMPs to the ground based on local site conditions. State BMPs, regional Forest Service guidance, land management plan standards and guidelines, monitoring results, and professional judgment are used to develop site-specific BMP prescriptions.

stormwater permit: A form of CWA 402 permit regulating stormwater discharges from industrial activities, including construction activities disturbing areas of 1 acre or larger (40 CFR 122.26).

stream simulation: A method of designing crossing structures (usually culverts) with the aim of creating within the structure a channel as similar as possible to the natural channel in both structure and function (USDA Forest Service 2008b).

swale: A landform feature lower in elevation than adjacent hillslopes, usually present in headwater areas of limited areal extent, generally without display of a defined watercourse or channel, which may or may not flow water in response to snowmelt or rainfall. Swales exhibit little evidence of surface runoff and may be underlain by porous soils and bedrock that readily accept infiltrating water. These areas are where soil moisture concentrates but often do not exhibit pedologic or botanical evidence of saturated conditions (Dunne and Leopold 1978).

underground injection system: Any manmade design, structure, or activity that places fluids, mainly stormwater, but also septic effluent, treated drinking water, and other fluids, below the ground.

unstable soils: Those soils that have properties that make them susceptible to dislodgement and downslope transport of soil and rock material under direct gravitational stress. The process includes slow displacement such as creep and rapid movements, such as landslides.

waterbody: Features such as rivers, streams, reservoirs, lakes, ponds, wet meadows, fens, bogs, marshes, and wetlands. A waterbody may be perennial, intermittent, or ephemeral.

water quality: The chemical, physical, and biological integrity of surface water and groundwater.

water right: A property right granted by a State for the use of a portion of the public's surface water resource obtained under applicable legal procedures.

Waters of the United States: (1) All waters that are currently used, were used in the past, or may be susceptible to be used in interstate or foreign commerce, including all waters that are subject to the ebb and flow of the tide; (2) all interstate waters, including interstate wetlands; (3) all other waters, such as intrastate lakes, rivers, streams (including intermittent streams), mudflats, sandflats, wetlands, sloughs, prairie potholes, wet meadows, playa lakes, or natural ponds that the use, degradation, or destruction of which would affect or could affect interstate or foreign commerce, including any such waters (a) that are or could be used by interstate or foreign travelers for recreational or other purposes, (b) from which fish or shellfish are or could be taken and sold in interstate or foreign commerce, or (c) that are used or could be used for industrial purposes by industries in interstate commerce; and (4) all impoundments of waters otherwise defined as waters of the United States under this definition, including (a) tributaries of waters identified in paragraphs 1 through 4 of this definition, (b) the territorial sea, and (c) wetlands adjacent to waters (other than waters that are themselves wetlands) identified in paragraphs (1) through (7) of this definition (40 CFR 122.2).

wetlands: Those areas that are inundated or saturated by surface or groundwater at a frequency and duration sufficient to support and that, under normal circumstances, do support, a prevalence of vegetation typically adapted for life in saturated soil conditions. Wetlands generally include swamps, marshes, bogs, and similar areas (40 CFR 122.2).

References

- Bedford, B.L.; Godwin K.S. 2003. Fens of the United States: Distribution, characteristics, and scientific connection versus legal isolation. *Wetlands*. 23(3): 608–629.
- Briggs, M.K. 1996. Riparian ecosystem recovery in arid lands, strategies, and references. Tucson, AZ: University of Arizona Press.
- Brown, T.C.; Hobbins, M.T.; Ramirez, J.A. 2008. Spatial distribution of water supply in the coterminous United States. *Journal of the American Water Resources Association*. 44(6): 1474–1487.
- Chimner, R.A.; Lemly, J.M.; Cooper, D.J. 2010. Mountain fen distribution, types and restoration priorities, San Juan Mountains, Colorado, USA. *Wetlands*. 30(4): 763–771.
- Clymo, R.S. 1983. Peat. In: Gore, A.J.P., ed. *Ecosystems of the world, Volume 4A, mires, swamp, bog, fen and moor general studies*. New York: Elsevier. 159–224.
- Cooper, D.J.; Andrus, R. 1994. Patterns of vegetation and water chemistry in peatlands of the west-central Wind River Range, Wyoming. *Canadian Journal of Botany*. 72: 1586–1597.
- Dunne, T.; Leopold, L.B. 1978. *Water in environmental planning*. San Francisco, CA: W.H. Freeman & Co. 818 p.
- Gorham, E. 1953. A note on the acidity and base status of raised and blanket bogs. *Journal of Ecology*. 41: 153–156.
- Holaday, S.; Wagner, C. 2010. Wisconsin's forestry best management practices for water quality: Field manual for loggers, landowners and land managers. Pub. FR-093. Madison, WI: Wisconsin Department of Natural Resources, Division of Forestry. 163 p. Available at <http://dnr.wi.gov/forestry/Usesof/bmp/bmpfieldmanual.htm>.
- Logan, R. 2001. Water quality BMPs for Montana forests. Missoula, MT: Montana State University Extension Service. 62 p. Available at <http://dnrc.mt.gov/forestry/Assistance/Practices/Documents/2001WaterQualityBMPGuide.pdf>.
- MacDonald, L.H.; Smart, A.W.; Wissmar, R.C. 1991. Monitoring guidelines to evaluate effects of forestry activities on streams in the Pacific Northwest and Alaska. EPA 910/9-91-001. Seattle, WA: U.S. Environmental Protection Agency and University of Washington. 166 p.
- Rosgen, D. 1996. *Applied River Morphology*. Pagosa Springs, CO: Wildland Hydrology Books. 363 p.
- Sedell, J.; Sharpe, M.; Apple, D.D. et al. 2000. *Water and the Forest Service*. FS-660. Washington, DC: U.S. Department of Agriculture, Forest Service. 26 p.
- U.S. Department of Agriculture (USDA), Forest Service. 2000. *Water quality management for Forest System lands in California. Best management practices*. Vallejo, CA: USDA Forest Service, Pacific Southwest Region. 138 p.
- U.S. Department of Agriculture (USDA), Forest Service. 2007. *Technical guide to managing groundwater resources*. FS-881. Washington, DC: USDA Forest Service. Available at <http://www.fs.fed.us/publications/>.

U.S. Department of Agriculture (USDA), Forest Service. 2008a. The U.S. Forest Service—An overview. Washington, DC: U.S. Department of Agriculture, Forest Service. 47 p.

U.S. Department of Agriculture (USDA), Forest Service. 2008b. Stream simulation: An ecological approach to providing passage for aquatic organisms at road-stream crossings. 0877-1801 SDTDC. San Dimas, CA: USDA Forest Service, National Technology and Development Program. Available at <http://www.stream.fs.fed.us/fishxing/index.html>.

U.S. Department of Agriculture (USDA), Forest Service. 2009a. Water quality protection on national forests in the Pacific Southwest Region: Best management practices evaluation program, 2003–2007. Vallejo, CA: USDA Forest Service, Pacific Southwest Region.

U.S. Department of Agriculture (USDA), Forest Service. 2009b. Summit mountain pine beetle salvage project, environmental analysis, appendix B—Best management practices. Bigfork, MT: USDA Forest Service, Flathead National Forest, Swan Lake Ranger District.

U.S. Department of Agriculture (USDA), Forest Service. 2010a. Black Hills National Forest FY 2009 monitoring and evaluation report. Custer, SD: USDA Forest Service, Black Hills National Forest.

U.S. Department of Agriculture (USDA), Forest Service. 2010b. Two decades of best management practices monitoring (1992–2010) final report, North Carolina National Forest. Asheville, NC: USDA Forest Service, National Forests of North Carolina.

U.S. Environmental Protection Agency (EPA). 1987. Nonpoint source controls and water quality standards. In: Water quality standards handbook, chapter 2 general program. Washington, DC: EPA.

U.S. Environmental Protection Agency (EPA), Office of Water. 1996. Biological criteria, technical guidance for streams and small rivers. EPA 822-B-96-001. Washington, DC: EPA Office of Water.

U.S. Environmental Protection Agency (EPA), Office of Water. 2007. Water quality standards handbook: second edition—Web version. EPA-823-B-94-005. (August 1994 with some additional new information June 2007.) Washington, DC: EPA Office of Water. Available at <http://www.epa.gov/waterscience/standards/handbook/>.

Ziesak, R. 2010. Montana forestry best management practices monitoring—2010 forestry BMP field review report. Missoula, MT: Montana Department of Natural Resources and Conservation, Forestry Division. 68 p.

Appendix A. Forest Service Regional Best Management Practices Guidance Documents

Forest Service Region	Best Management Practices Document	Available at:
Northern Region (Region 1)	FSH 2509.22, Soil and Water Conservation Practices (1988)	http://www.fs.fed.us/publications/
Rocky Mountain Region (Region 2)	FSH 2509.25, Watershed Conservation Practices Handbook (2006)	http://www.fs.fed.us/publications/
Southwest Region (Region 3)	FSH 2509.22, Soil and Water Conservation Practices	http://www.fs.fed.us/publications/
Intermountain Region (Region 4)	FSH 2509.22, Soil and Water Conservation Practices (1988)	http://www.fs.fed.us/publications/
Pacific Southwest Region (Region 5)	Water Quality Management for National Forest System Lands in California (2000)	http://www.fs.fed.us/r5/publications/water_resources/waterquality/index.html
Pacific Northwest Region (Region 6)	General Water Quality Best Management Practices (1988)	—
Southern Region (Region 8)	Soil and Water Conservation Practices Guide (2002)	http://fsweb.r8.fs.fed.us/nr/bio_phy_res/water/Literature.shtml
Eastern Region (Region 9)	—	—
Alaska Region (Region 10)	FSH 2509.22 Soil and Water Conservation Practices (2006)	http://www.fs.fed.us/publications/

Appendix B. Selected State Forestry Best Management Practices Documents^a

State	Best Management Practices Document	Available at:
Alabama	Alabama's Best Management Practices for Forestry	http://www.forestry.state.al.us/publications/BMPs/2007_BMP_Manual.pdf
Alaska	Implementing Best Management Practices for Timber Harvest Operations from the Alaska Forest Resources and Practices Regulations	http://forestry.alaska.gov/forestpractices.htm#acts
Arkansas	Best Management Practices for Water Quality Protection	http://forestry.arkansas.gov/Services/ManageYourForests/Documents/bmpbookrevise.pdf
Colorado	Forestry Best Management Practices to Protect Water Quality in Colorado	http://www.csfs.colostate.edu/pdfs/ForestryBMP-CO-2010.pdf
Florida	Silviculture Best Management Practices	http://www.fl-dof.com/forest_management/index.html
Georgia	Georgia's Best Management Practices for Forestry	http://www.gfc.state.ga.us/ForestManagement/bmp.cfm
Idaho	Compendium of Best Management Practices to Control Polluted Runoff: A Source Book	http://www.deq.State.id.us/water/data_reports/surface_water/nps/reports.cfm#bmps
Illinois	Forestry Best Management Practices	http://coas.siu.edu/docs/BMPbooklet2.pdf
Indiana	Indiana Forestry BMPs—protecting the woods while harvesting	http://www.in.gov/dnr/forestry/files/BMP.pdf Additional BMPs at http://www.in.gov/dnr/forestry
Kentucky	Kentucky Forest Practice Guidelines for Water Quality Protection	http://www.ca.uky.edu/forestryextension/publications_BMPs.pdf
Louisiana	Recommended Forestry Best Management Practices for Louisiana	http://www.ldaf.state.la.us/portal/offices/Forestry/ForestManagement/BestManagementPractices/tabid/232/Default.asp
Maine	Best Management Practices for Forestry: Protecting Maine's Water Quality	http://www.maine.gov/doc/mfs/pubs/bmp_manual.htm
Michigan	Sustainable Soil and Water Quality Practices on Forest Land	http://michigan.gov/documents/dnr/IC4011_SustainableSoilandWaterQualityPracticesonForestLand_268417_7.pdf
Minnesota	Sustaining Minnesota Forest Resources: Voluntary Site-level Forest Management Guidelines for Landowners, Loggers and Resource Managers	http://www.frc.state.mn.us/resources_documents_management.html
Mississippi	Mississippi's BMPs—Best Management Practices for Forestry in Mississippi	http://www.mfc.ms.gov/water-quality.php
Missouri	Missouri Watershed Protection Practice—2006 Management Guidelines for Managing Forested Watersheds to Protect Streams	http://mdc.gov/landwater-care/stream-and-watershed-management
Montana	Water Quality BMPs for Montana Forests	http://www.dnrc.mt.gov/forestry/Assistance/Practices/Documents/2001WaterQualityBMPGuide.pdf
Nevada	Best Management Practices Handbook	http://www.cicacenter.org/pdf/NVBMPHandbook.pdf
New Hampshire	Best Management Practices for Forestry: Protecting New Hampshire's Water Quality	http://extension.unh.edu/resources/248/Best_Management_Practices_for_Forestry_Protecting_NH's_Water_Quality
New Mexico	New Mexico Forest Practices Guidelines	http://www.emnrd.state.nm.us/FD/Publications/documents/NM_ForestPracticesGuidelines2008.pdf
New York	New York State Forestry Best Management Practices for Water Quality, BMP Field Guide, 2011 Edition.	http://www.nysbmpguidelines.com

State	Best Management Practices Document	Available at:
North Carolina	North Carolina Forestry Best Management Practices Manual to Protect Water Quality	http://www.ncforests-service.gov/water_quality/bmp_manual.htm
North Dakota	North Dakota Forestry Best Management Practices	http://www.ndsu.edu/fileadmin/ndfs/docs/r_forestry/BMP_2010_FINAL_DOC_11_12_10.pdf
Ohio	BMPs for Erosion Control for Logging Practices in Ohio	http://ohioline.osu.edu/b916/index.html
Oregon	Forest Practices Act Rulebook	http://oregon.gov/ODF/privateforests/fpaguidance.shtml
Pennsylvania	Best Management Practices for Pennsylvania's Forests—promoting forest stewardship through education, cooperation, and voluntary action	http://www.dcnr.state.pa.us/ucmprd1/groups/public/documents/document/dcnr_005564.pdf
South Carolina	South Carolina's BMPs for Forestry	http://www.state.sc.us/forest/bmpmanual.pdf
South Dakota	Forestry Best Management Practices for South Dakota	http://sdda.sd.gov/Forestry/publications.PDF/Forestry-BMP.pdf
Tennessee	Guide to Forestry Best Management Practices in Tennessee	http://www.tn.gov/agriculture/publications/forestry/BMPs.pdf
Texas	Texas Forestry Best Management Practices	http://texasforests-service.tamu.edu/main/article.aspx?id=75&terms=bmps
Utah	Utah's Forest Water Quality Guidelines—A Technical Manual for Landowners, Loggers and Resource Managers	http://forestry.usu.edu/htm/rural-forests/forest-management/best-management-practices-bmps-and-water-quality
Vermont	Acceptable Management Practices for Maintaining Water Quality on Logging Jobs in Vermont	http://www.vtfpr.org/watershed/ampprog.cfm
Virginia	Virginia's Forestry Best Management Practices for Water Quality Technical Manual	http://www.dof.virginia.gov/wq/index-BMP-Guide
Washington	Title 222 WAC – Forest Practices Rules	http://www.dnr.wa.gov/BusinessPermits/Topics/ForestPracticeRules/Pages/fs_rules.aspx
West Virginia	West Virginia Silvicultural Best Management Practices for Controlling Soil Erosion and Sedimentation from Logging Operations.	http://www.wv.forestry.com/BMP%20Book%Complete.pdf
Wisconsin	Wisconsin's forestry best management practices for water quality: Field manual for loggers, landowners and land managers	http://dnr.wi.gov/forestry/Usesof/bmp/bmpfieldmanual.htm
Wyoming	Wyoming Forestry Best Management Practices—Forestry BMPs, Water Quality Protection Guidelines	http://slf-web.state.wy.us/oldsite/forestry/bmp2.aspx

* Forestry BMP documents for States that contain NFS lands.

ATTACHMENT C: SDG&E SOIL EROSION CONTROL BMP DETAILS

BMP DETAILS 4



Section 4 - Soil Erosion Control

What is Erosion?

Erosion is the detachment of soil particles by water or wind. Erosion is a natural process that can be accelerated by construction activities such as grading and trenching. For example, when a site is cleared and grubbed, protective vegetation is removed and the disturbed soil is directly exposed to wind, rain, and flowing water.

Why is Erosion Control Required?

Water or wind can transport soil particles to water bodies where they can cause damage to, or destruction of, aquatic animals and plants by burying them or reducing oxygen and/or sunlight that is necessary for their survival. Erosion control is required by regulatory agencies to minimize the potential additional erosion and damage to the environment from construction activities.

What is Erosion Control?

Erosion Controls are methods used to protect the soil surface and prevent the soil particles from being detached and transported by rain, flowing water or wind. Erosion controls include limiting soil or vegetation disturbance to reduce erosion. Preservation of Existing Vegetation is an example of an Erosion Control BMP.

Soil Stabilization is the most widely used and most effective method of erosion control. Preventing or reducing erosion potential by directing or controlling drainage runoff, as well as preparing and stabilizing disturbed soil areas protects the exposed soil surface from rain and wind thereby preventing erosion. Diversion Berms and Drainage Swales is an example of an erosion control BMP that intercepts and conveys run-on around or through the project reducing erosion potential. Hydroseeding is also an example of an erosion control BMP that stabilizes the soil. Erosion control BMPs used in this Manual to direct or control runoff and/or stabilize soil include:

- BMP 4-01 Preservation of Existing Vegetation
- BMP 4-02 Temporary Soil Stabilization (General)
- BMP 4-03 Hydraulic Mulch
- BMP 4-04 Hydroseeding
- BMP 4-05 Soil Binders
- BMP 4-06 Straw Mulch
- BMP 4-07 Geotextiles, Plastic Covers, and Erosion Control Blankets/Mats
- BMP 4-08 Dust (Wind Erosion) Control
- BMP 4-09 Diversion Berms and Drainage Swales
- BMP 4-10 Velocity Dissipation Devices
- BMP 4-11 Slope Drains
- BMP 4-12 Streambank Stabilization
- BMP 4-13 Soil Preparation

EROSION CONTROL AND SOIL STABILIZATION

Preservation of Existing Vegetation

BMP 4-01



What Preservation of Existing Vegetation is a procedural BMP that maximizes the preservation of existing trees, shrubs, bushes, and grasses on a construction or operations and maintenance activity site.

When This BMP is applicable to utility activities when there is existing vegetation.

Where All construction and operations and maintenance activity sites where:

- There are areas on site where no activity is planned or will occur later.
- There are areas with vegetation that can be preserved to protect against soil erosion, such as on steep slopes, watercourses, and building sites in wooded areas.
- There are areas designated as ESAs, or where federal, state, or local government regulations require preservation, such as wetlands, vernal pools, marshes, etc.

How Use the following measures as applicable:

- Preserve existing vegetation whenever possible.
- Identify areas to be preserved in the immediate vicinity of the construction or activity site, and mark as appropriate before clearing and grubbing or other soil disturbance activities.
- If necessary, contact the project Field Environmental Representative for any clarification regarding areas to be preserved.
- Whenever possible, minimize disturbed areas by locating temporary roadways to avoid stands of trees and shrubs and follow existing contours to reduce cutting and filling.
- Construction materials, equipment storage and parking areas should be located outside the drip line of any tree to be retained.
- Consider the impact of grade changes to existing vegetation and the root zone.
- Remove any markings, barriers, or fencing after project is completed.
- Maintain the clearly marked limits of disturbance during construction to preserve vegetation.
- Inspect barriers regularly during construction.

**Maintenance
and
Inspection
Pictures**



Vegetation to be preserved is marked and outside the work area.

**Corresponding
CASQA
Fact Sheet**

Fact Sheet EC-2



What	<p>Temporary Soil Stabilization is a procedural BMP utilizing protective materials to cover exposed soil, where the soil exposure is caused by construction or operation and maintenance activities. Materials may include hydraulic mulch and seeding, soil binders, straw, geotextiles, plastic covers and erosion control blankets.</p> <p>Temporary soil stabilization BMPs and their associated materials include:</p> <ul style="list-style-type: none">• BMP 4-03 - Hydraulic Mulch• BMP 4-04 - Hydroseeding• BMP 4-05 - Soil Binders• BMP 4-06 - Straw Mulch• BMP 4-07 - Geotextiles, Plastic Covers and Erosion Control Blankets/Mats
When	<p>This BMP, and the situation appropriate BMPs listed above, is applicable when slopes are constructed or disturbed and/or where there are inactive soil disturbance areas that will not be worked for 14 days or more. The procedures are to be implemented after slope construction activity is complete and then prior to the onset of precipitation.</p>
Where	<ul style="list-style-type: none">• Slopes, soil stockpiles, and inactive disturbed soil areas.• Soil binders (BMP 4-05) may be applicable to areas where there is light traffic that would minimize the effectiveness of other temporary soil stabilization BMPs.
How	<ul style="list-style-type: none">• Sediment control BMPs used to break up the slope lengths, such as fiber rolls (BMP 1-03) or gravel bag berms (BMP 1-04) should be spaced in accordance with the CGP requirements (see installation for BMP 1-03 "Fiber Rolls")• Permanent erosion control shall be applied to areas deemed substantially complete during the project's defined seeding season window.• Refer to individual temporary soil stabilization BMPs for specific instructions for use (see BMP 4-03 through BMP 4-07).
Maintenance and Inspection	<ul style="list-style-type: none">• Refer to individual temporary soil stabilization BMPs listed above for maintenance and inspection requirements.

Pictures



Applying a tackifier using a trailer mounted pump and hose.



Applying soil stabilization manually in harder to reach areas.

**Corresponding
CASQA
Fact Sheet**

Fact Sheet EC-2



What	<p>Hydraulic Mulch is a procedural BMP for applying mulch to protect the soil surface from wind and rain erosion.</p> <p>Mulch consists of a mixture of shredded wood fiber or other fiber in water and a stabilizing emulsion, or tackifier. The mulch is applied with hydro-mulching equipment (water mixture spraying equipment).</p>
When	<p>Hydraulic mulch is typically applied when a temporary soil cover is required for protection until permanent vegetation is established, or to disturbed areas that must be re-disturbed following a period of inactivity of 14 or more days.</p>
Where	<ul style="list-style-type: none"> • To disturbed areas requiring temporary protection. • Do not apply to active work areas where the mulch would interfere with or be destroyed by immediate earthwork activities or construction traffic. Consider using soil binders instead (BMP 4-05).
How	<ul style="list-style-type: none"> • Prior to application, roughen embankment and fill areas with a crimping or punching type roller or by track walking. Track walking shall only be used where other methods are impractical and slope angle allows safe equipment operation. Track walking must be performed upslope so that equipment tracks traverse the slope horizontally along the slope. • Avoid mulch over-spray onto the traveled way, sidewalks, lined drainage channels, and existing vegetation. • Avoid use of mulch without a tackifier component, especially on slopes. • Hydraulic Mulches: <ul style="list-style-type: none"> ○ Apply as liquid slurry using a hydraulic application machine (i.e., hydroseeder) at rates of mulch and stabilizing emulsion recommended by the manufacturer. Wood fiber hydraulic mulches are generally short-lived (only last a part of a growing season) and must be applied no less than 24 hours before rain events to dry and become effective. <ul style="list-style-type: none"> • Hydraulic Mulch with Binder (Matrix): ○ Apply a combination of wood fiber and/or paper fiber mixed with acrylic polymers as binders. Apply the mulch matrix as liquid slurry using a hydraulic application machine (i.e., hydroseeder) at rates recommended by the manufacturer. Hydraulic matrices must be applied no less than 24 hours before a rain event to dry and become effective. <ul style="list-style-type: none"> • Bonded Fiber Matrix (BFM): ○ Apply BFM using a hydraulic application machine (mulch and tackifier are pre-mixed in a single bag) in accordance with manufacturer's instructions. Do not apply immediately before, during, or after a rain event. ○ Note that cellulose fiber mulches alone may not perform well on steep slopes or in coarse soils.
Maintenance and Inspection	<ul style="list-style-type: none"> • Maintain an unbroken, temporary mulched ground cover throughout the period of construction when the soils are not being reworked. Inspect before expected rain and repair any damaged ground cover and re-mulch areas of exposed soil (e.g., weekly, or in compliance with the frequency specified in the project specific SWPPP, if applicable). • After any rain event, maintain all slopes to prevent erosion.



Pictures



Applying hydraulic mulch.



Close-up of bonded fiber matrix

Corresponding CASQA Fact Sheet

Fact Sheet EC-3



- What** Hydroseeding is a procedural BMP for the application of vegetation seed in a protective mixture for both soil and seed. The seed then sprouts, providing vegetation that provides additional soil erosion control (holds the soil in place and shields the soil from erosion). Hydroseeding material typically consists of a mixture of fiber, seed, fertilizer, and stabilizing emulsion.
- When**
- When temporary protection is needed until permanent vegetation protection can be established. Temporary vegetation should not be used for more than 3 to 6 months.
 - Avoid using hydroseeding during dry weather periods, unless supplemental irrigation is used.
- Where**
- Use on disturbed soil areas that must be re-disturbed following construction inactivity of 14 or more days.
 - Avoid use of hydroseeding in areas where the BMP would be incompatible with site conditions. These conditions include:
 - Slopes steeper than 1:3 vertical: horizontal. Steep slopes are difficult to protect with temporary seeding.
 - Traffic areas, where construction or other traffic would prevent seed sprouting or vegetation growth. Consider using soil binders instead (see BMP 4-05).
- How**
- Hydroseeding can be accomplished using a multiple-step (with straw mulch) or a one-step process (mixed with hydraulic mulch, hydraulic matrix, or bonded fiber matrix). When the one-step process is used to apply the mixture of fiber, seed, etc., the seed rate shall be increased to compensate for all seed not having direct contact with the soil. Confirm with your project Field Environmental Representative the appropriate seed mix to be used.
 - Prior to application roughen the slope, fill area, or area to be seeded with the furrows trending along the contours.
 - Apply straw mulch as necessary to keep seeds in place and to moderate soil moisture and temperature until the seeds germinate and grow.
 - Follow-up applications shall be made as needed to cover weak spots, and to maintain adequate soil protection.
 - Avoid over-spray onto the travel way, sidewalks, drainage channels and existing vegetation.
- Maintenance and Inspection**
- All seeded areas shall be inspected for failures and re-seeded, fertilized, and mulched within the planting season, using not less than half the original application rates. Any temporary re-vegetation effort that does not provide adequate cover must be re-vegetated.
 - After any rainfall event, maintain all slopes to prevent erosion.

Pictures



Applying hydroseed.

**Corresponding
CASQA
Fact Sheet**

Fact Sheet EC-4



What	Soil Binders is a procedural BMP for applying soil binder material to the soil surface to temporarily prevent water-induced erosion of exposed soils on construction or applicable operations and maintenance sites. Soil binders bind with the soil, creating a crust that sheds water and prevents the water erosion. Soil binders also provide temporary dust, wind, and soil stabilization benefits.
When	<p>Soil binders are typically applied to disturbed soil areas that require short-term temporary protection.</p> <p>Soil binders have the following application timing limitations:</p> <ul style="list-style-type: none"> • May not cure when low temperatures occur within 24 hours of application. • Soil binders generally experience spot failures during heavy rain and may need reapplication after a storm. • Some soil binders may not perform well during periods of low relative humidity.
Where	<p>Soil binders can be used for any disturbed soil area. Soil binders can often be incorporated into the work so they may be a good choice for areas where grading activities will soon resume or that experience light construction traffic.</p> <p>Soil binders have the following limitations for particular areas of application:</p> <ul style="list-style-type: none"> • Soil binders may not penetrate areas where soil surfaces are made up primarily of silt and clay, particularly when compacted. • Soil binders may not hold up well in areas of heavy pedestrian or medium to heavy vehicular traffic.
How	<p>Selection of soil binders should be approved by the project Field Environmental Representative after an evaluation of site-specific factors. Chemical soil binders must be on the SDG&E List of Approved Products. These approved soil binder products have low or no toxicity to aquatic organisms and wildlife and may not trigger the construction site sampling requirements of the CGP. Follow manufacturer's recommendations for application procedures and cleaning of equipment after use. Any onsite cleaning must use appropriate BMPs (BMP 2-02 "Material Use", 2-03 "Spill Control", 2-04 "Solid Waste Management", 2-08 "Liquid Waste/Drilling Fluid Management", and 3-03 "Vehicle and Equipment Washing").</p> <ul style="list-style-type: none"> • Prior to application, roughen embankment and fill areas. Track walking shall only be used where rolling is impractical. • Soil binders should not be applied during or immediately before rain events. Soil binders must be applied no less than 24 hours before rain to cure and dry and become fully effective. • Avoid over-spray onto paths, sidewalks, lined drainage channels, sound walls, and existing vegetation. • Do not apply soil binders to frozen soil, areas with standing water, under freezing conditions, or when the temperature is below 40°F during the curing period. • More than one treatment is often necessary, although the second treatment may be diluted or have a lower application rate. • For liquid agents: <ul style="list-style-type: none"> ○ Crown or slope ground to avoid ponding. ○ Uniformly pre-wet ground according to manufacturer's recommendations. ○ Apply solution under pressure. Overlap solution 6 to 12 inches.





How (cont')

- Allow treated area to cure for the time recommended by the manufacturer; typically at least 24 hours.
- Apply second treatment before first treatment becomes ineffective, using 50 percent application rate.
- In low humidity, reactivate chemicals by re-wetting according to manufacturer's recommendations.

Maintenance and Inspection

- Reapplying the selected soil binder may be needed for proper maintenance. Traffic areas should be inspected routinely.
- After any rainfall event, maintain all slopes to prevent erosion.

Pictures

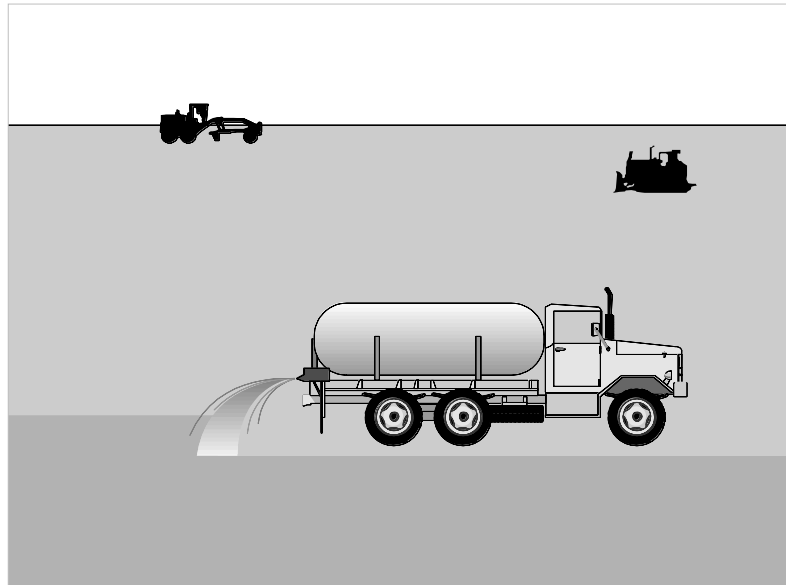

Corresponding CASQA Fact Sheet

Fact Sheet EC-5



What	Straw Mulch is a procedural BMP for the application of a uniform layer of straw to exposed soil surfaces to protect exposed soil from rain and wind erosion. Straw mulch consists of straw, and may incorporate a tackifier emulsion for stabilization of the mulch when used for protecting sloped areas of exposed soil.
When	<p>Straw mulch is used when:</p> <ul style="list-style-type: none">• Temporary soil stabilization surface cover is needed on disturbed areas until soils can be prepared for re-vegetation and permanent vegetation is established.• In combination with temporary and/or permanent seeding strategies to enhance plant establishment. Straw mulch typically lasts less than six months. <p>Limitation: There is a potential for introduction of weed-seed and unwanted plant material with straw. Certified Weed free rice straw must be used when it is important not to introduce unwanted plants.</p>
Where	Application of straw mulch is applicable to flat areas of exposed soil and areas of exposed soil with gradual slopes.
How	<p>Use tackifier to anchor straw mulch to the soil on slopes. Tackifiers act to glue the straw fibers together and to the soil surface, and the tackifier shall be selected based on longevity and ability to hold the fibers in place. Soil binders (tackifier) will generally experience spot failures during heavy rain events. A tackifier is typically applied at a rate of 125 pounds per acre. In windy conditions, the rates are typically 150 pounds per acre.</p> <ul style="list-style-type: none">• Crimping, punch roller-type rollers, or track-walking may also be used to incorporate straw mulch into the soil on slopes. Track walking shall only be used where other methods are impractical.• Avoid placing straw onto construction traffic ways, sidewalks, lined drainage channels, and existing vegetation.• Straw mulch with tackifier shall not be applied during or immediately before rain events.• Apply loose straw at a rate between 3,000 and 4,000 pounds per acre (lb/acre), either by machine using a straw blower or by hand distribution and provide 100 percent ground cover. Use a lighter application on flat surfaces and a heavier application on slopes.• The straw mulch must be evenly distributed on the soil surface.• Anchor mulch in place by "punching" it into the soil mechanically in lieu of using a tackifier. "Punching" of straw does not work in sandy soils.• Methods for holding the straw mulch in place depend on the slope steepness, accessibility, soil conditions and longevity. If the selected method is incorporation of straw mulch into the soil, then proceed as follows:<ul style="list-style-type: none">○ A tackifier acts to glue the straw fibers together and to the soil surface. Selection of a tackifier should be based on longevity and ability to hold the fibers in place. Application of a tackifier is typically at a rate of 125 lb/acre and 180 lb/acre in windy conditions.○ On very small areas, a spade or shovel can be used.○ On soil slopes which are stable enough, and gradually sloped to safely support construction equipment without contributing to compaction and instability problems, straw can be "punched" into the ground using a knife-blade roller or a straight bladed coultter, known commercially as a "crimper."



How (cont')

- On small areas and/or steep slopes, straw can also be held in place using plastic netting or jute. The netting shall be held in place using 11 gauge wire staples, geotextile pins or wooden stakes (BMP 4-07), “
- On small areas and/or steep slopes, straw can also be held in place using plastic netting or jute. The netting shall be held in place using 11 gauge wire staples, geotextile pins or wooden stakes (BMP 4-07, “Geotextiles, Plastic Covers, and Erosion Control Blankets/Mats”).
- Remove straw as necessary prior to permanent seeding or soil stabilization.

Maintenance and Inspection

- The key consideration in maintenance and inspection is that the straw needs to last long enough to achieve erosion control objectives.
- Reapplication of straw mulch and tackifier may be required to maintain effective soil stabilization over disturbed areas and slopes.
- After any rain event, inspect and maintain all slopes and straw mulch cover to prevent erosion.

Pictures



Straw mulch.

Corresponding CASQA Fact Sheet

Fact Sheet EC-6



What This Erosion Control and Soil Stabilization BMP is a procedural BMP for the installation of specific erosion control soil stabilization materials to control erosion from wind and water. These materials consist of:

- Geotextile blankets/mats,
- Plastic covers, and
- Natural/man-made material erosion control blankets.

Geotextiles are permeable fabrics typically made from polypropylene (plastic) or polyester that have the ability to protect the soil from erosion but are able to allow some water to reach and to drain the soil. Geotextile fabrics come in three basic forms: woven, needle punched, or heat bonded. Geotextiles also allow controlled rate and filtered drainage from a slope for slope moisture control, while providing slope reinforcement and protection.

Plastic Covers, such as Visqueen, are essentially impermeable and are used for immediate, temporary protection.

Erosion control blankets/mats are meant to protect exposed soil from wind and rain impact and reduce the speed at which water moves across the soil surface. These blankets can be made out of straw, coconut fiber, aspen fiber, jute, and polypropylene. Permeability varies according to material and material weave.

When

- Use blankets/mats when disturbed soils, especially on moderate to steep slopes, are difficult to stabilize or access. Due to wildlife concerns, consult with your project Field Environmental Representative for any restrictions on using these products on your project.

- Geotextile blanket/mats should be used when slope reinforcement may be required.
- Geotextile blankets/mats and natural fiber blankets/mats (depending on their permeability) are used when it is important to allow some water to reach the soil for seed germination or allow slope drainage for moisture control.

Where

- Blankets and mats are generally not suitable for excessively rocky sites or areas where the final vegetation will be mowed (because staples and netting can catch in mowers).

- Plastic results in 100 percent runoff, therefore, their use is limited to:
 - Covering small stockpiles.
 - Covering small graded areas for short periods, such as through an imminent storm event, until alternative measures may be installed.
 - Note the CGP discourages the use of plastic materials for cover when more sustainable alternatives can be used.

Blankets/mats should be used where there are:

- Steep slopes, generally steeper than 1:3 (vertical: horizontal).
- Slopes where the erosion hazard is high.
- Slopes and disturbed soils where mulches would need to be anchored.
- Disturbed areas where plants are slow to develop adequate protective cover.
- Channels with high flows.
- Channels intended to be vegetated.
- Slopes adjacent to water bodies or ESAs).

How For blankets or mat materials, proper site preparation is essential to ensure complete contact of the blanket or matting with the soil.



How (cont.)

- Grade and shape the area of installation.
- Remove all rocks, clods, vegetation or other obstructions so that the installed blankets or mats will have complete, direct contact with the soil.
- Prepare seedbed by loosening of topsoil.
- Seed the area before blanket installation for erosion control and vegetation. Seeding after mat installation is often specified for turf reinforcement. When seeding prior to blanket installation, all check slots and other areas disturbed during installation must be re-seeded. Where soil filling is specified, seed the matting and the entire disturbed area after installation and prior to filling the mat with soil.
- U-shaped wire staples, metal geotextile stake pins, or triangular wooden stakes can be used to anchor mats and blankets to the ground surface.
- Wire staples and metal stakes should be driven flush to the soil surface.
- All anchors should be 6 inches to 18 inches long and have sufficient ground penetration to resist pullout. Longer anchors may be required for loose soils.
- Installation on slopes - Consult the manufacturer's recommendations for installation. In general, these will be as follows:
 - Begin at the top of the slope and anchor the blanket in a 6 inch deep by 6 inch wide trench. Backfill trench and tamp earth firmly.
 - Unroll blanket down slope in the direction of water flow.
 - Overlap the edges of adjacent parallel rolls 2 inches to 3 inches and staple every 3 feet.
 - When blankets must be spliced, place blankets end over end (shingle style) with a 6 inch overlap. Staple through overlapped area, approximately 12 inches apart.
 - Lay blankets loosely and maintain direct contact with the soil. Do not stretch.
 - Staple blankets sufficiently to anchor blanket and maintain contact with the soil. Staples shall be placed down the center and staggered with the staples placed along the edges.
- Blankets and mats must be removed and disposed of prior to application of permanent soil stabilization measures.
- For plastic sheeting, it is important for the entire stockpile or exposed soil area to be covered completely, and the plastic firmly anchored with anchor objects spaced evenly along the entire perimeter so that wind, or storm water run-on, does not uncover the stockpile. Suitable anchors are gravel bags, sand bags, hay bales, or other non-polluting objects that can be safely handled.

Maintenance and Inspection

- Areas covered with temporary soil stabilization should be inspected routinely and before and after significant forecasted storm events. Any failures should be repaired immediately. Areas covered with temporary soil stabilization should be maintained to provide adequate erosion control. Temporary soil stabilization should be reapplied or replaced on exposed soils when greater than 10 percent of the previously covered area becomes exposed or exhibits visible erosion.
- If washout or breakage occurs, re-install the material after repairing the damage to the slope or channel.

Pictures



Several types of erosion control blankets.

**Corresponding
CASQA
Fact Sheet**

Fact Sheet EC-7



What	Dust (Wind Erosion) control is a procedural BMP that consists of applying water or other dust suppressant to prevent or alleviate dust nuisance generated by construction and operations and maintenance activities.
When	<ul style="list-style-type: none"> • Dust control must be used whenever wind speed picks up dust and creates visual dust emissions. Dust control should be used at least initially on any project when exposed soil is subject to vehicle traffic and soil disturbance activities (e.g., dirt construction site, dirt access road traffic, grading, excavating, and soil stockpile generation, or soil removal from soil stockpiles). • Dust control must be implemented in accordance with local air quality requirements.
Where	All construction and operations and maintenance activity sites where exposed soil is susceptible to wind erosion.
How	<p>Use the following measures as applicable:</p> <ul style="list-style-type: none"> • Appropriate methods of applying dust control (water, chemical dust suppressant, or soil covers and the means to apply it) should be available for construction or operation and maintenance activity sites with the potential to create dust. • Water applied for dust control should be applied evenly and in a manner that does not generate runoff. • Dust control methods should be approved by the project Field Environmental Representative. A construction permit or an agency rule may require specific control procedures. • Obtain prior approval to use any chemical dust suppressant from the project Field Environmental Representative. Dust suppressant chemicals must be on SDG&E's approved product list • Non-potable water should not be conveyed in tanks or drainpipes that will be used to convey potable water, and there should be no connection between potable and non-potable supplies. Non-potable tanks, pipes and other conveyances should be marked "NON-POTABLE WATER - DO NOT DRINK." Approval for use of all non-potable sources of water must be obtained from the project Field Environmental Representative. • If reclaimed wastewater is used for dust control, the sources and discharge must meet California Department of Health Services water reclamation criteria and RWQCB requirements. Approval for use of reclaimed wastewater must be obtained from the project Field Environmental Representative.
Maintenance and Inspection	<ul style="list-style-type: none"> • Check areas protected to ensure coverage. • Reapply water, chemical dust suppressants, or maintain soil covers as necessary to maintain their effectiveness.



EROSION CONTROL AND SOIL STABILIZATION

Dust (Wind Erosion) Control

BMP 4-08



Pictures



Water being applied for dust control.

Corresponding CASQA Fact Sheet

Fact Sheet WE-1



- What** A diversion berm is a temporary berm of compacted soil used to direct runoff water to a desired location. A drainage swale is a shaped and sloped soil depression used to convey runoff to a desired location. Diversion berms and drainage swales divert off site runoff around the construction or operation and maintenance site, divert runoff from flowing onto stabilized areas and disturbed areas, and direct runoff into sediment basins or traps. A diversion berm or swale itself does not control erosion or remove or trap sediment from runoff.
- Limitations:
- Diversion berms may create disturbed areas and become construction equipment barriers.
 - Diversion berms must be stabilized immediately, adding cost and maintenance.
 - Diverted storm water may cause downstream flood damage.
 - Berms should not be constructed of easily eroded soils.
 - Regrading the site to remove the berm may add cost.
 - Other soil stabilization and sediment controls such as check dams, plastics, and blankets may be needed to prevent erosion in newly graded berms and swales.
 - Sediment accumulation, scour depression, and/or persistent non-storm water discharges can result in standing water suitable for mosquito production.
- When** Diversion berms and drainage swales are suitable for use, individually or together, where runoff needs to be diverted from one area to another. These BMPs may be used:
- To direct runoff away from disturbed areas or at the top of slopes.
 - To convey surface runoff down sloping land.
 - To divert runoff towards a stabilized watercourse, drainage pipe, or channel.
 - To intercept runoff from paved surfaces.
 - To divert sediment laden runoff into sediment basins or traps.
- Where** Diversion berms and drainage swales should be considered:
- At the top of slopes to divert run-on from adjacent or undisturbed slopes.
 - At bottom and mid-slopes to intercept sheet flow and convey concentrated flows.
 - Below steep grades where runoff begins to concentrate.
 - Along roadways and facility improvements subject to flood drainage.
 - Berms should not be used for drainage areas greater than 10 acres or along slopes greater than 10 percent. For larger drainage areas, more permanent drainage structures should be built in accordance with local requirements.
 - Drainage areas more than 5 acres should not drain to a temporary drainage swale. For larger drainage areas, use berms, or more permanent drainage structures should be built in accordance with local requirements.
- How** Berms and swales should not adversely affect adjacent properties and must conform to local floodplain management regulations. Obtain written



How (cont.)

authorization from property owner to divert runoff onto another property.

- Care must be applied to correctly size and locate berms and drainage swales.
- Conveyances and outlets should be stabilized.
- Size to control flow velocity based on evaluation of the erosion risk, soil types, overtopping, flow backups, washout, and site drainage flow patterns.
- Install permanent berms and swales early in the construction process.

Diversion Berms:

- Compact all berms and provide positive drainage to an outlet.
- All berms should have 1:2 (vertical: horizontal) or flatter side slopes, and minimum 18-inch height, and minimum 24-inch top width. Wide top widths and flat slopes are usually needed for construction traffic crossings.
- Runoff should be conveyed to a sediment trapping device when the berm channel or the drainage area above the berm are not adequately stabilized.
- Temporary stabilization may be achieved using seed and mulching for slopes less than 5 percent and either riprap or sod for slopes greater than 5 percent. Stabilization should be completed immediately after installation/placement.
- If riprap is used to stabilize the channel formed along the toe of the berm, the following typical specifications apply:

Channel Grade	Riprap Stabilization
0.5 - 1%	4 inch Rock
1.1 - 2.0%	6 inch Rock
2.1 - 4.0%	8 inch Rock
4.1 - 5.0%	8 to 12 inch Riprap

- The riprap, recycled concrete, etc. should be pressed into the soil with construction equipment.
- Filter fabric may be used to cover berms in use for long periods.
- Construction activity on the earthen berms should be kept to a minimum.

Drainage Swales:

Standard engineering design criteria for small open channel and closed conveyance systems should be used. Unless local drainage design criteria state otherwise, drainage swales should be designed as follows:

- Place drainage swales above or below, not on, a cut or fill slope.
- Swale bottom width should be at least 2 feet, and the depth of the swale should be at least 18 inches. The swale side slopes should be 1:2 (vertical: horizontal) or flatter.
- Drainage swales should be at a grade of at least 1 percent, but not more than 15 percent.
- The swale must not be overtopped by the peak discharge from a 10-year storm, irrespective of the design criteria above.



How (cont.)

- Remove all vegetation and other objectionable materials and compact the fill material along the swale path.
- Stabilize all swales immediately after installation/placement. Seed and mulch swales with slopes of less than 5 percent and use riprap or sod for swales with slopes between 5 and 15 percent. For temporary swales, geotextiles and mats may provide immediate stabilization.
- Irrigation may be required to establish sufficient vegetation to prevent erosion.
- Do not operate vehicles across a swale unless a stabilized crossing is provided.
- Permanent drainage facilities must be designed by a California Registered Civil Engineer.
- At a minimum, the drainage swale should conform to predevelopment drainage patterns and capacities.
- Construct the drainage swale with a positive grade to a stabilized outlet.
- Provide erosion protection or energy dissipation measures if the flow out of the drainage swale can reach erosive velocity.
- Inspect berms and drainage swales dams prior to, daily during, and after each storm event, and routinely throughout the construction activity (e.g., weekly, or in compliance with the frequency specified in the CGP, if applicable).
- Inspect BMPs subject to non-storm water discharges daily while the discharges occur.
- Inspect ditches and berms for washouts and erosion. Repair riprap, damaged linings, or soil stabilizers, and linings as needed.
- Inspect channel linings, embankments, and beds of swales and berms for erosion and accumulation of debris and sediment. Remove accumulated debris and sediment as needed. Removed sediment shall be incorporated in the project at appropriate locations or disposed of in accordance with federal, state and local requirements.
- Temporary conveyances should be completely removed as soon as the surrounding drainage area has stabilized or at the completion of construction.

Maintenance and Inspection

Pictures

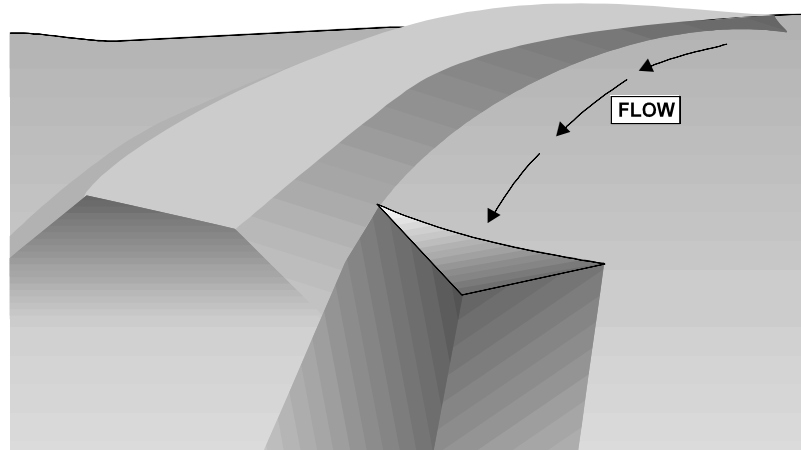

EROSION CONTROL AND SOIL STABILIZATION

Diversion Berms and Drainage Swales



**Corresponding
CASQA
Fact Sheet**

Fact Sheet EC-9



- What** Velocity dissipation devices are composed of rock, riprap, grouted riprap or concrete rubble, placed at the outlet of a pipe, channel, or waterbar to prevent scour and erosion caused by concentrated high velocity flows. There are many types of dissipation devices.
- Limitations:
- Large storms or high flows can wash away the outlet protection and leave the area susceptible to erosion.
 - Sediment captured by the outlet protection may be difficult to remove without removing the protection.
 - Outlet protection may negatively impact the channel habitat.
 - Grouted riprap may break up in areas of freeze and thaw.
 - With inadequate drainage, water may build up behind and break grouted riprap.
 - Sediment accumulation, scour depression, and/or persistent non-storm water discharges can result in standing water suitable for mosquito production.
- When** Velocity dissipation devices are suitable when discharge velocities and energies at the outlets of culverts, conduits, waterbars, or channels are sufficient to erode the next downstream reach.
- Where** Velocity dissipation devices should be considered:
- At outlets of pipes, drains, culverts, slope drains, diversion ditches, swales, conduits, channels, waterbars, etc.
 - At outlets located at the bottom of mild to steep slopes.
 - At discharge outlets that carry continuous water flow.
 - At outlets subject to short, intense water flows, such as flash floods.
 - At points where lined conveyances discharge to unlined conveyances.
- How** Depth of flow, roughness, gradient, side slopes, discharge rate, and velocity should be considered in the outlet design. Compliance to local and state regulations should be considered, particularly while working in environmentally sensitive streambeds.
- Determine the apron length and rock size gradation using the discharge pipe diameter and estimated discharge rate table below. Select the longest apron length and largest rock size suggested by the pipe size and discharge rate. Recommendations for rock size and length of outlet protection mat should be considered minimums. Use sound, durable, and angular rock.
 - Where flows are conveyed in open channels such as ditches or swales, use the estimated discharge rate for selecting the apron length and rock size. Flows should be the same as the culvert or channel design flow but never less than the peak 5 year flow for temporary structures planned for one rainy season, or the 10 year peak flow for temporary structures planned for two or three rainy seasons.
 - Install filter fabric, riprap, grouted riprap, or concrete apron at selected outlet. Install filter fabric or well-graded filter layer beneath the riprap apron. Riprap aprons are best suited for temporary use during construction. Grouted or wired riprap can minimize maintenance.
 - Rock outlet protection is usually less expensive and easier to install than concrete aprons or energy dissipaters, and serves to trap sediment and reduce flow velocities.



**How
(cont.)**

- Carefully place riprap to avoid damaging the underlying filter fabric.
 - Rock 4 to 6-inches may be carefully dumped onto the filter fabric from a maximum height of 12 inches.
 - 8- to 12-inch rock must be hand placed onto filter fabric, or the filter fabric may be covered with 4 inches of gravel, and the rock may be dumped from a maximum height of 16 inches.
 - Rock greater than 12 inches shall only be dumped onto filter fabric protected with a layer of gravel with a thickness equal to one-half the D_{50} rock size, with the dump height limited to twice the gravel protection layer thickness.
- Align apron with receiving stream and keep straight throughout its length. If a curve is needed to fit site conditions, place it in the upper section of the apron.
- Outlets on slopes steeper than 10 percent should have additional protection.

Pipe Diameter (in)	Discharge (ft ³ /s)	Apron Length (ft)	Min. Riprap D_{50} Diameter (in)
12	5	10	4
	10	13	6
18	10	10	8
	20	16	12
	30	23	16
	40	26	8
24	30	16	8
	40	26	12
	50	26	16
	60	30	8

**Maintenance
and
Inspection**

- Inspect velocity dissipation devices prior to and after each rain event, and daily during extended rain events throughout the construction activity (e.g., weekly, or in compliance with the frequency specified in the project specific SWPPP, if applicable). Initiate repairs related to a storm event within 72 hours of identifying the problem or as soon as possible but prior to the next predicted storm event, per the CGP.
- Inspect BMPs subject to non-storm water discharges daily while the discharges occur. Minimize standing water by removing sediment blockages and filling depressions.
- Inspect apron for displacement of the riprap and damage to the underlying fabric. Repair fabric and replace riprap that has washed away. If riprap continues to wash away, consider using larger material.
- Inspect for scour beneath the riprap and around the outlet. Repair damage to slopes or underlying filter fabric immediately.
- Temporary devices should be completely removed as soon as the surrounding drainage area has been stabilized or at the completion of construction.

EROSION CONTROL AND SOIL STABILIZATION

Velocity Dissipation Devices



Pictures

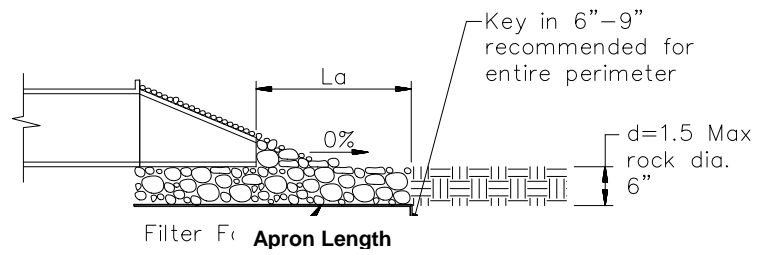
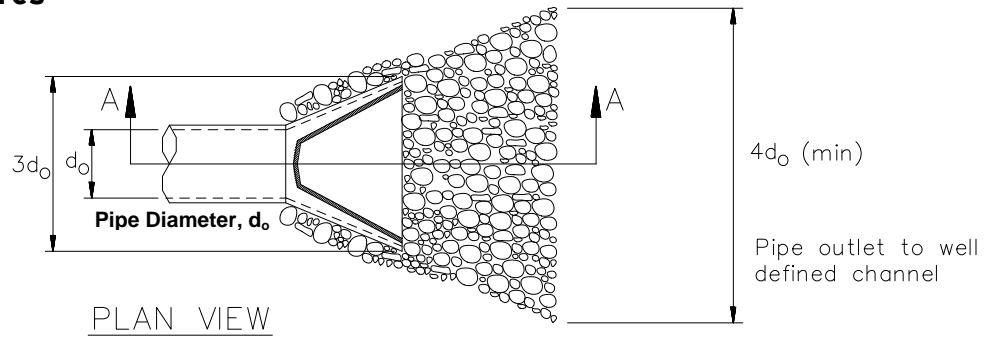

**Corresponding
CASQA
Fact Sheet**

Fact Sheet EC-10



What A slope drain is a pipe used to intercept and direct surface runoff or groundwater into a stabilized watercourse, trapping device, or stabilized area. Slope drains are typically used with diversion berms and drainage ditches to intercept and direct surface flow away from slope areas to protect cut or fill slopes. Slope drains prevent storm water from flowing directly down the slope by confining the runoff into an enclosed pipe or channel. The slope drain may be installed as a rigid pipe, such as corrugated metal, a flexible conduit, or a lined terrace drain with a top of a slope inlet and a bottom of a slope outlet.

Limitations:

- Slope drain sizing, installation, and maintenance is critical to minimize the potential for failure. Severe erosion may result when slope drains fail by overtopping, pipe separation, or other signs of erosion.
- Dissipation of high flow velocities at the pipe outlet is required to avoid erosion.
- Sediment accumulation, scour depression, and/or persistent non-storm water discharges can result in standing water suitable for mosquito production.

When Slope drains are suitable when:

- Concentrated runoff flow must be conveyed down a slope.
- Drainage is needed for top of slope diversion dikes or swales.
- Drainage is needed for top of cut and fill slopes where water can accumulate.
- Emergency spillway is required for a sediment basin.

Where Slope drains should be considered where:

- The drainage area is less than 10 acres per slope drain. For larger areas, use a rock-lined channel, or subdivide into areas of 10 acres or less, with each area is treated as a separate drainage.
- Drainage areas exceeding 10 acres must be designed by a California Registered Civil Engineer and approved by the agency that issued the grading permit.

How

- Permanent structures included in the project plans can often serve as construction BMPs if implemented early. However, the permanent structure must meet or exceed the criteria for the temporary structure.
- Slope drains and inlets must be securely attached to the slope and must be adequately sized to carry the capacity of the design storm and associated forces.
- Outlets must be stabilized with riprap, concrete, or other type of energy dissipater, or directed into a stable sediment trap or basin.
- Debris racks are recommended at the inlet. Debris racks are barriers used to collect debris that is too large to pass through the inlet. Debris racks located several feet upstream of the inlet can usually be larger than racks at the inlet, and thus provide enhanced debris protection and less plugging.



How (cont.)

- Safety racks are also recommended at the inlet and outlet of pipes to prevent a human body or animal from washing into the pipe and/or becoming trapped.
- Size to convey at least the peak flow of a 10-year storm. The design storm is conservative due to the potential impact of system failures. The pipe size may be computed using the Rational Method or a method established by a local municipality. Higher flows must be safely stored or routed to prevent any offsite concentration of flow or erosion. Maximum slope generally limited to 1:2 (vertical: horizontal) as energy dissipation below steeper slopes is difficult.
- Direct surface runoff to slope drains with interceptor dikes. Top of interceptor dikes should be 12 inches higher than the top of the slope drain.
- Slope drains can be placed on or buried beneath the slope surface.
- As a guide, temporary slope drains should not be sized smaller than shown in the following table:

Minimum Pipe Diameter (inches)	Maximum Drainage Area (Acres)
12	1.0
18	3.0
21	5.0
24	7.0
30	10.0

- Recommended materials include metal, plastic, or concrete pipe, either corrugated or smooth wall. The following types of slope drains are common:
 - Rigid Pipe: Also known as a pipe drop, the pipe usually consists of corrugated metal pipe or rigid plastic pipe. The pipe is placed on undisturbed or compacted soil and secured to the slope surface or buried in a trench. Concrete thrust blocks must be used when warranted by the calculated thrust forces. Collars should be properly installed and secured with straps or watertight collars.
 - Flexible Pipe: The pipe consists of a flexible tube of heavy duty plastic, rubber, or composite material. The tube material is securely anchored to the slope surface. The tube should be securely fastened to the metal inlet and outlet conduit sections with metal straps or watertight collars.
 - Section Downdrains: The section downdrain consists of a pre-fabricated, section conduit of half round or third round material, and performs similar to a flume or chute. The pipe must be placed on undisturbed or compacted soil and secured into the slope.
 - Concrete-Lined Terrace Drain: This concrete channel drains water from a slope terrace to the next level. These drains are typically specified as permanent structures and should be designed according to local criteria. If installed early, they can be construction slope drains.

How



- (cont.)** When installing slope drains:
- Install perpendicular to slope contours.
 - Compact soil around and under entrance, outlet, and along length of pipe.
 - Securely anchor and stabilize pipe appurtenances into soil.
 - Check to ensure that pipe connections are watertight.
 - Protect areas around inlet with filter fabric. A flared end section installed at the inlet will improve flow into the slope drain and prevent erosion at the pipe entrance. Use a flared section with a 6-inch minimum toe plate to help prevent undercutting. The flared section should slope towards the pipe inlet.
 - Protect outlet with riprap or other energy dissipation device. Protect outlet of slope drains using a flared end section when outlet discharges to a flexible energy dissipation device.
- Maintenance and Inspection**
- Inspect slope drains prior to and after each storm event, and daily during extended rain events throughout the construction activity (e.g., weekly, or in compliance with the frequency specified in the project specific SWPPP, if applicable). Initiate repairs related to a storm event within 72 hours of identifying the problem or as soon as possible but prior to the next predicted storm event, per the CGP.
 - Inspect BMPs subject to non-storm water discharges daily while the discharges occur. Minimize standing water by removing sediment blockages and filling depressions.
 - Inspect outlet for erosion and downstream scour. If eroded, repair damage and install additional energy dissipation measures. If downstream scour is occurring, it may be necessary to reduce flows being discharged into the channel unless other preventative measures are implemented.
 - Insert inlet for clogging or undercutting. Remove debris from inlet to maintain flows. Repair undercutting at inlet, and if needed, install flared section or riprap around the inlet to prevent further undercutting.
 - Inspect pipes for leakage. Repair leaks and restore damaged slopes.
 - Inspect slope drainage for accumulations of debris and sediment. Remove sediment from entrances and outlets as required. Flush drains as necessary; capture and settle out sediment from discharge.
 - Ensure water is not ponding onto inappropriate areas (e.g. active traffic lanes, material storage areas, etc.).
 - Pipe anchors must be checked to ensure that the pipe remains anchored to the slope. Install additional anchors if pipe movement is detected.

Pictures

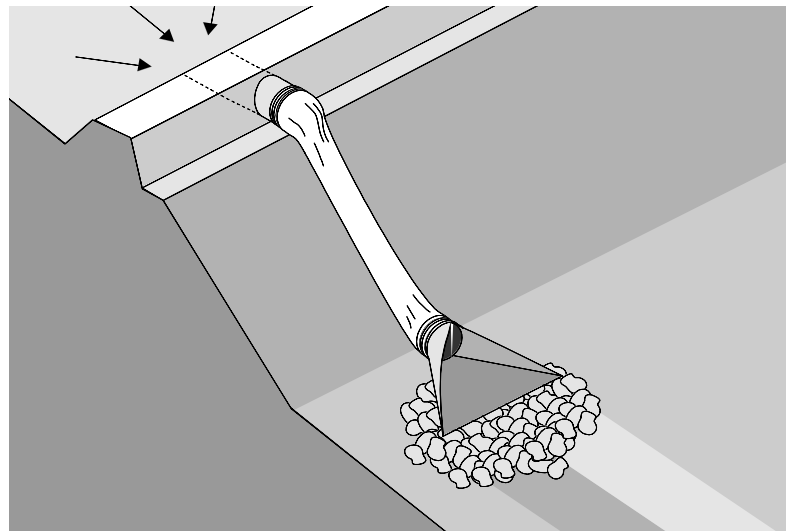

**Corresponding
CASQA
Fact Sheet**

Fact Sheet EC-11



What Streambank stabilization includes measures to reduce the discharge of sediment from streambanks with exposed or disturbed soil, or unstable banks. Streambank stabilization measures include preservation of existing vegetation, hydraulic mulch, hydroseeding, soil binders, straw mulch, geotextiles and mats, berms, and drainage swales, velocity dissipation devices, and slope drains. Streambank sediment controls include silt fences, fiber rolls, gravel bag berms, rock filters, and K-rail barriers, and padding. Each of these measures have different applications, limitations, and maintenance requirements for use as streambank stabilization.

Stream channels, streambanks, and associated riparian areas are dynamic and sensitive ecosystems that respond to changes in land use. Streams on the 303(d) list and listed for sediment may require numerous measures to prevent any increases in sediment load to the stream.

General streambank stabilization limitations:



- **Specific permit requirements or mitigation measures such as RWQCB 401 Certification, U.S. Army Corps of Engineers 404 permit and approval by the California Department of Fish and Game supersede the guidance in this BMP.**
- If numerical water quality standards are mentioned in any of these and other related permits, testing and sampling may be required. Soil disturbance activities in watersheds having streams listed as 303(d) impaired for sediment, silt, or turbidity, may require sampling to verify that there is no net increase in sediment load.

When When construction or operations and maintenance activities occur within stream channels and associated riparian areas.

Where Streambank stabilization procedures apply to all construction projects and operations and maintenance activities that disturb or occur within stream channels and their associated riparian areas.

How Planning should account for: scheduling; avoidance of wet in-stream construction; minimizing disturbance and construction time period; selecting crossing location; and selecting equipment.



- **Construction and operation and maintenance activities should be scheduled according to the relative sensitivity of the environmental concerns and will be different when working near perennial streams vs. ephemeral streams.**
- Minimize disturbance by using pre-disturbed areas, selecting the narrowest crossing location, limiting vehicle crossing trips, and minimizing the number and size of work areas. Plan work areas at least 50 feet from the stream channel.
- Avoid steep and unstable banks, highly erodible or saturated soils, or highly fractured rock.
- Select a project or work site that minimizes disturbance to aquatic species or habitat.
- Select equipment that reduces the amount of pressure exerted on the ground surface (less than 5 or 6 pounds per square inch where possible).



Maintenance and Inspection

- Inspect streambank stabilization BMPS prior to and after each storm event, and daily during extended rain events throughout the construction activity (e.g., weekly, or in compliance with the frequency specified in the project specific SWPPP, if applicable). Initiate repairs related to a storm event within 72 hours of identifying the problem or as soon as possible but prior to the next predicted storm event, per the CGP.
- Inspect BMPs subject to non-storm water discharges daily while the discharges occur.
- Inspect and repair equipment (for damaged hoses, fittings, and gaskets, etc.).

Pictures



Cobble or gravel armor used for streambank stabilization.

Corresponding CASQA Fact Sheet

Fact Sheet EC-12



What Soil preparation/roughening involves assessment and preparation of surface soils for BMP installation. This includes soil testing (for seed base, soil characteristics, or nutrients), or roughening surface soils by mechanical methods (including sheepsfoot rolling, track walking, scarifying, stair stepping, and imprinting) to prepare soils for additional BMPs or to break up sheet flow. Soil preparation can also involve tilling topsoil to prepare a seed bed and/or incorporation of soil amendments to enhance vegetative establishment. Various roughening techniques on slopes can result in a significant erosion reduction as compared to smooth slopes.

Limitations:

- Preparation and roughening must take place prior to installing other erosion controls (such as hydraulically applied stabilizers) or sediment controls (such as fiber rolls) on slope faces.
- In cases where slope preparation is minimal, erosion control/revegetation BMPs that do not require extensive soil preparation (such as hydraulic mulching and seeding applications) should be employed.
- Consideration should be given to the type of erosion control BMP that follows surface preparation, as some BMPs are not designed to be installed over various types of tillage/roughening.

When

- Soil preparation is most effective when used in combination with erosion controls. Soil preparation (i.e. tilling, raking, and amendment) is essential to proper vegetative establishment, and suitable in combination with any soil stabilization method, including rolled erosion control products (RECPs) or sod.
- Soil roughening is suitable for use as a complementary process to soil preparation for controlling erosion, and is not intended to be used as a stand-alone BMP. Soil roughening should be used with perimeter controls, additional erosion control measures, grade breaks, and vegetative establishment for maximum effectiveness. Soil roughening is referred to as track walking (sometimes called imprinting) a slope, where treads from heavy equipment run parallel to the slope contours and create terraces. Roughening is intended to only affect surface soils and should not compromise slope stability or overall compaction.

Where Soil preparation should be considered:

- Where vegetation is desired.

Soil roughening should be considered:

- Along any disturbed slopes, including temporary stockpiles, sediment basins, or compacted soil diversion berms and swales.
- Roughening should be used in combination with hydraulically applied stabilization methods, compost blankets, or straw mulch; but should not be used in combination with RECPs or sod because roughening is intended to leave terraces on the slope.

How Minimal materials are required unless amendments and/or seed are added to the soil. Most soil roughening/preparation can be done with standard construction equipment.



How (cont.)

Soil Preparation

- Where appropriate, soil should be prepared to receive the seed by disking or scarifying the surface to eliminate crust, improve air and water infiltration and create a more favorable environment for germination and growth.
- Based on soil testing, apply additional soil amendments (e.g. fertilizers, additional seed) to the soil to help with germination.

Cut Slope Roughening

- Stair-step grade or groove the cut slopes steeper than 1:3 (vertical: horizontal).
- Use stair-step grading on any erodible material soft enough to be ripped with a bulldozer. Slopes consisting of soft rock with some subsoil are well suited to stair-step grading.
- Make the vertical cut distance less than the horizontal distance, and slightly slope the horizontal position of the "step" in toward the vertical wall.
- Do not make individual vertical cuts more than 2 feet or 3 feet high in soft or rock materials, respectively.
- Groove the slope using machinery to create a series of ridges and depressions that run across the slope on the contour.

Fill Slope Roughening

- Place on fill slopes with inclinations steeper than 1:3 (vertical: horizontal) in lifts not to exceed 8 inches, and ensure that each lift is properly compacted.
- Ensure that the slope face consists of loose, uncompacted fill 4 to 6 inches deep.
- Use grooving or tracking to roughen the face of slopes, if necessary.
- Do not blade or scrape the final slope face.

Roughening for Slopes to be Mowed

- Slopes which require mowing should be flatter than 1:3 (vertical: horizontal).
- Roughen these areas to shallow grooves by track walking, scarifying, sheepsfoot rolling, or imprinting. Excessive roughness is undesirable when mowing is planned.
- Space grooves less than 10 inches apart, and not less than 1 inch deep, and perpendicular to the direction of runoff (parallel to the slope contours).

Roughening with Tracked Machinery

- Limit roughening with tracked machinery to soils with a sandy textural component to avoid undue compaction of the soil surface.
- Operate tracked machinery up and down the slope to leave horizontal depressions in the soil. Do not back-blade during the final grading operation.



**How
(cont.)
Maintenance
and
Inspection**

- Seed and mulch roughened areas as soon as possible to obtain optimum seed germination and growth.
- Inspect BMPs prior to and after each storm event, and daily during extended rain events throughout the construction activity (e.g., weekly, or in compliance with the frequency specified in the project specific SWPPP, if applicable). Initiate repairs related to a storm event within 72 hours of identifying the problem or as soon as possible but prior to the next predicted storm event, per the CGP.
- Check the seeded slopes for signs of erosion such as rills and gullies. Fill these areas slightly above original grade, then reseed and mulch as soon as possible.

Pictures



Sheepsfoot used for soil preparation

**Corresponding
CASQA
Fact Sheet**

Fact Sheet EC-15

REFERENCES

CASQA, 2009. California Stormwater Quality Association Stormwater Best Management Practice Handbook Portal: Construction, November 2009. <https://www.casqa.org>.

Sempra Energy, December 2002. Water Quality Construction Best Management Practices Manual.

ATS	Active Treatment Systems
Base	Construction and Operations Center
BFM	Bonded Fiber Matrix
BMP	Best Management Practices
Caltrans	California Department of Transportation
CASQA	California Stormwater Quality Association
CGP	California Construction General Permit
ES	Environmental Standard
ESA	Environmentally Sensitive Area
gpm	Gallons per minute
lb/acre	Pounds per acre
LID	Low Impact Development
NPDES	National Pollutant Discharge Elimination System
RWQCB	Regional Water Quality Control Board - there are nine Water Boards located throughout California that are responsible for enforcing water quality standards within their individual boundaries.
SDG&E	San Diego Gas & Electric
SUSMP	Standard Urban Storm Water Mitigation Plan
SWMP	Storm Water Management Plan
SWPPP	Storm Water Pollution Prevention Plan
SWRCB	State Water Resources Control Board - The State Board is responsible for protecting and preserving water quality and water rights in California.
Watershed	The total land area that contributes water to a river, stream, lake, or other body of water. Synonymous with drainage basin.
WDR	Waste Discharge Requirements

ATTACHMENT D: SWPPP BMP SITE MAPS

ATTACHMENT D-1: C78, TL625B AND TL629E SWPPP BMP SITE MAP

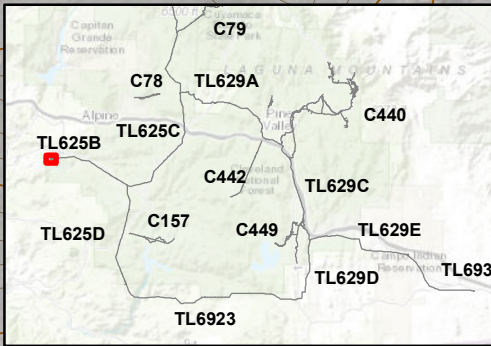

Site Map
TL625B Map 1 of 10

SDG&E MSUP and PTC
Power Line Replacement Projects

- LUP TYPE I PROJECT**
- N New Steel Pole
 - S Wood-to-Steel Replacement Pole
 - R Removal Pole
 - Tie Line (TL)
 - - - - - Tie Line (TL) Undergrounding
 - Stringing Site
 - - - - - Access Road
 - Stream
 - ▶ Flow Direction
 - 100-ft Contour Interval
 - 20-ft Contour Interval
 - Storm Drain Inlet Protection (BMP 1-06)
 - ◆ Tracking Control (BMP 1-07)
 - - - - - Fiber Roll (BMP 1-03)

- SWPPP Notes:
1. Locations of SWPPP BMPs are not to scale.
 2. SWPPP BMP locations are conceptual in nature and must be field-verified prior to construction.
 3. Erosion and sediment controls shall be deployed prior to pavement or soil disturbance (where applicable) and as recommended by the QSP.
 4. SDG&E BMP Details for sediment controls, erosion controls, waste management controls, and non-storm water discharge controls are contained within Appendix XI Construction BMPs of the Project SWPPP.
 5. Preserve existing vegetation within all designated construction areas in accordance with BMP 4-01.
 6. Track-out shall be removed at the end of every business day and as frequently as necessary to keep adjacent roads clean and free of sediment.
 7. Dust control shall be implemented as necessary during construction in accordance with dust (wind erosion) control Bmp 4-08.
 8. All trash containers are required to be covered at all times.
 9. Additional SWPPP BMPs shall be implemented as dictated by site conditions and as recommended by the QSP to prevent erosion and pollutant transport.

1:3,400
0 200 400 Feet

Z:\Projects\SDGE_CNF_ESRP\MapData\BMP_Detailed_Route_v3.mxd

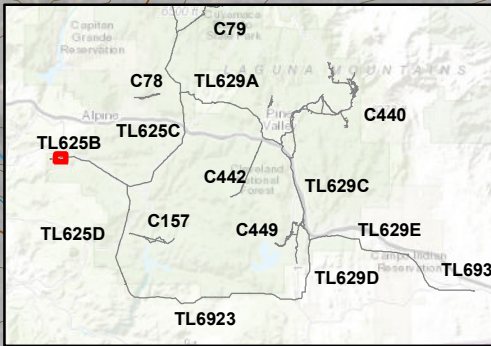

Site Map
TL625B Map 2 of 10

SDG&E MSUP and PTC
Power Line Replacement Projects

LUP TYPE I PROJECT

- (N) New Steel Pole
- (S) Wood-to-Steel Replacement Pole
- (R) Removal Pole
- Tie Line (TL)
- Stringing Site
- - - - Access Road
- Stream
- ▶ Flow Direction
- 100-ft Contour Interval
- 20-ft Contour Interval
- ☀ Preservation of Vegetation (BMP 4-01)
- ▬▬▬▬ Fiber Roll (BMP 1-03)

- SWPPP Notes:
1. Locations of SWPPP BMPs are not to scale.
 2. SWPPP BMP locations are conceptual in nature and must be field-verified prior to construction.
 3. Erosion and sediment controls shall be deployed prior to pavement or soil disturbance (where applicable) and as recommended by the QSP.
 4. SDG&E BMP Details for sediment controls, erosion controls, waste management controls, and non-storm water discharge controls are contained within Appendix XI Construction BMPs of the Project SWPPP.
 5. Preserve existing vegetation within all designated construction areas in accordance with BMP 4-01.
 6. Track-out shall be removed at the end of every business day and as frequently as necessary to keep adjacent roads clean and free of sediment.
 7. Dust control shall be implemented as necessary during construction in accordance with dust (wind erosion) control Bmp 4-08.
 8. All trash containers are required to be covered at all times.
 9. Additional SWPPP BMPs shall be implemented as dictated by site conditions and as recommended by the QSP to prevent erosion and pollutant transport.

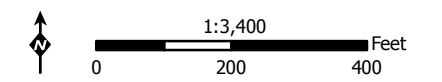



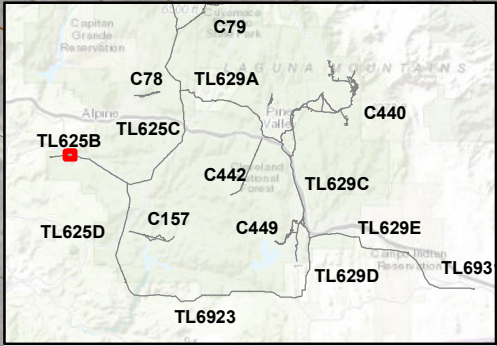









Z:\Projects\SDG&E CNF_ESR\PMX\DelPana\SWPPP\BMP_Detailed_Route_v3.mxd



Site Map
TL625B Map 3 of 10

SDG&E MSUP and PTC
Power Line Replacement Projects

- LUP TYPE I PROJECT**
-  Wood-to-Steel Replacement Pole
 -  Removal Pole
 -  Tie Line (TL)
 -  Stringing Site
 -  Access Road
 -  Stream
 -  Flow Direction
 -  100-ft Contour Interval
 -  20-ft Contour Interval
 -  Preservation of Vegetation (BMP 4-01)
 -  Velocity Dissipation Device (CASQA EC-10)
 -  Fiber Roll (BMP 1-03)
 -  Gravel Bag Berm (BMP 1-04)

- SWPPP Notes:
- Locations of SWPPP BMPs are not to scale.
 - SWPPP BMP locations are conceptual in nature and must be field-verified prior to construction.
 - Erosion and sediment controls shall be deployed prior to pavement or soil disturbance (where applicable) and as recommended by the QSP.
 - SDG&E BMP Details for sediment controls, erosion controls, waste management controls, and non-storm water discharge controls are contained within Appendix XI Construction BMPs of the Project SWPPP.
 - Preserve existing vegetation within all designated construction areas in accordance with BMP 4-01.
 - Track-out shall be removed at the end of every business day and as frequently as necessary to keep adjacent roads clean and free of sediment.
 - Dust control shall be implemented as necessary during construction in accordance with dust (wind erosion) control Bmp 4-08.
 - All trash containers are required to be covered at all times.
 - Additional SWPPP BMPs shall be implemented as dictated by site conditions and as recommended by the QSP to prevent erosion and pollutant transport.

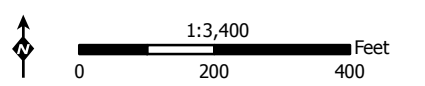

Z:\Projects\SDGE_CNF_ESRP\MapData\BMP_SWPPP\BMP_Detailed_Route_v3.mxd

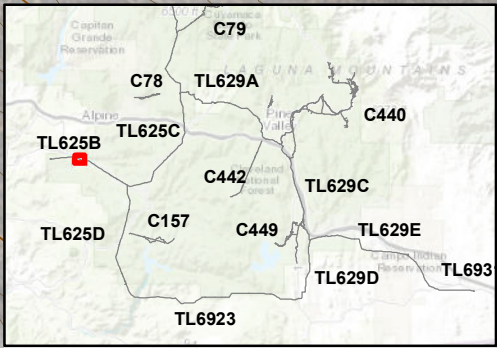

Site Map
TL625B Map 4 of 10

SDG&E MSUP and PTC
Power Line Replacement Projects

- LUP TYPE I PROJECT**
- Wood-to-Steel Replacement Pole
 - Tie Line (TL)
 - Staging Area
 - Access Road
 - Stream
 - Flow Direction
 - 100-ft Contour Interval
 - 20-ft Contour Interval
 - Sanitary/Septic Waste Management (BMP 2-07)
 - Material Delivery and Storage (BMP 2-01)
 - Secondary Containment Required (BMP 2-03)
 - Tracking Control (BMP-1-07)
 - Fiber Roll (BMP 1-03)

- SWPPP Notes:
1. Locations of SWPPP BMPs are not to scale.
 2. SWPPP BMP locations are conceptual in nature and must be field-verified prior to construction.
 3. Erosion and sediment controls shall be deployed prior to pavement or soil disturbance (where applicable) and as recommended by the QSP.
 4. SDG&E BMP Details for sediment controls, erosion controls, waste management controls, and non-storm water discharge controls are contained within Appendix XI Construction BMPs of the Project SWPPP.
 5. Preserve existing vegetation within all designated construction areas in accordance with BMP 4-01.
 6. Track-out shall be removed at the end of every business day and as frequently as necessary to keep adjacent roads clean and free of sediment.
 7. Dust control shall be implemented as necessary during construction in accordance with dust (wind erosion) control Bmp 4-08.
 8. All trash containers are required to be covered at all times.
 9. Additional SWPPP BMPs shall be implemented as dictated by site conditions and as recommended by the QSP to prevent erosion and pollutant transport.

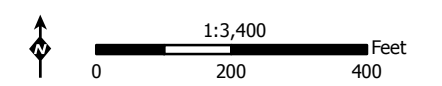



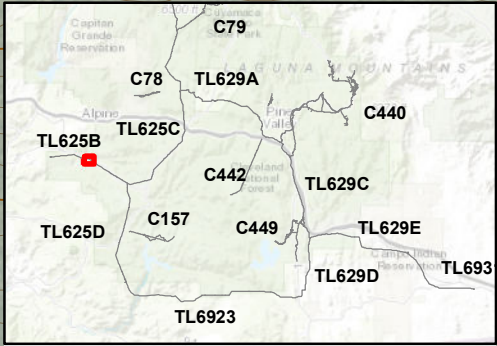
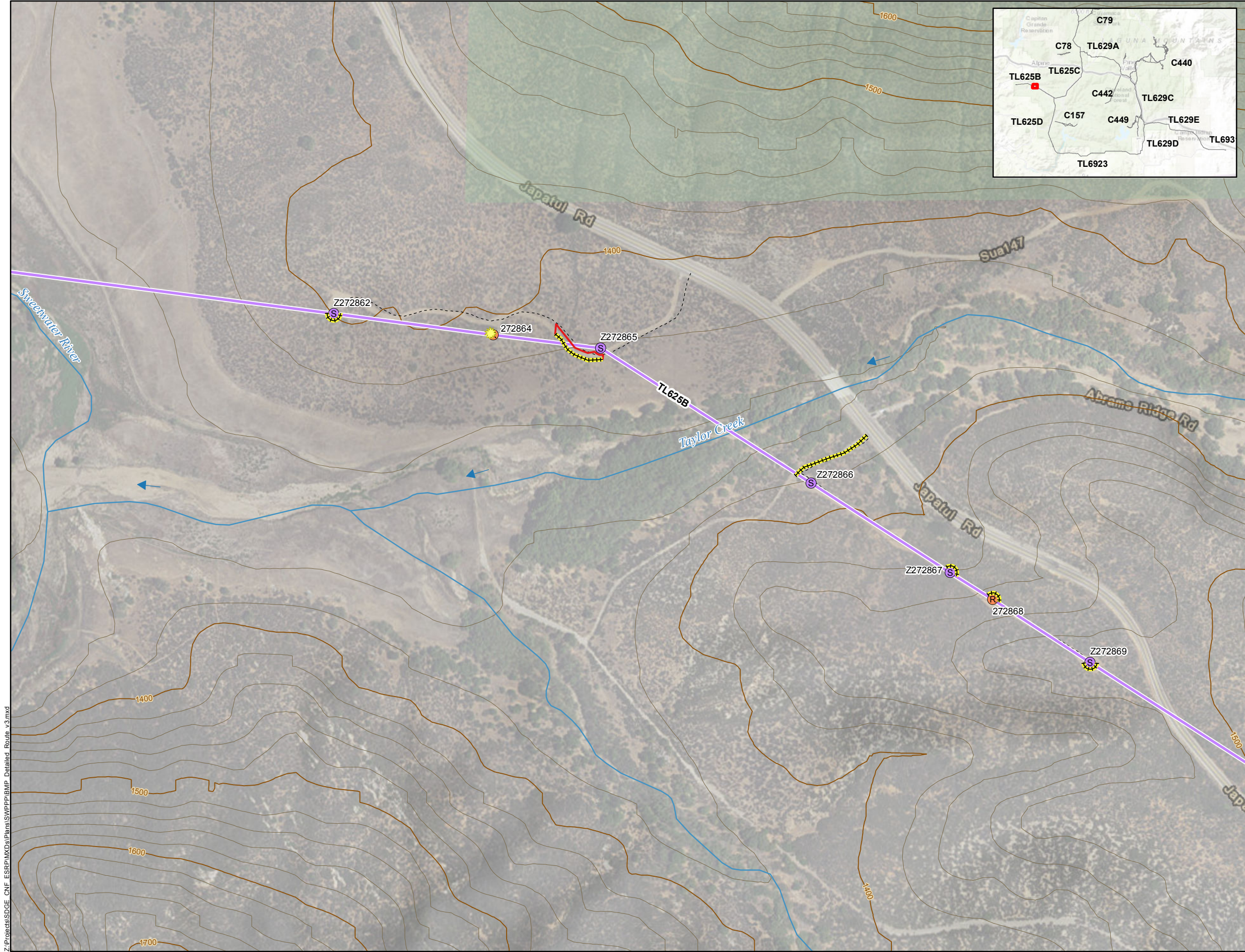









Z:\Projects\SDG&E_CNF_ESR\PMX\DelPana\SWPPP\BMP_Detailed_Route_v3.mxd





Site Map
TL625B Map 5 of 10

SDG&E MSUP and PTC
Power Line Replacement Projects

- LUP TYPE I PROJECT**
-  Wood-to-Steel Replacement Pole
 -  Removal Pole
 -  Tie Line (TL)
 -  Stringing Site
 -  Access Road
 -  Stream
 -  Flow Direction
 -  100-ft Contour Interval
 -  20-ft Contour Interval
 -  United States Forest Service
 -  Preservation of Vegetation (BMP 4-01)
 -  Fiber Roll (BMP 1-03)

- SWPPP Notes:
1. Locations of SWPPP BMPs are not to scale.
 2. SWPPP BMP locations are conceptual in nature and must be field-verified prior to construction.
 3. Erosion and sediment controls shall be deployed prior to pavement or soil disturbance (where applicable) and as recommended by the QSP.
 4. SDG&E BMP Details for sediment controls, erosion controls, waste management controls, and non-storm water discharge controls are contained within Appendix XI Construction BMPs of the Project SWPPP.
 5. Preserve existing vegetation within all designated construction areas in accordance with BMP 4-01.
 6. Track-out shall be removed at the end of every business day and as frequently as necessary to keep adjacent roads clean and free of sediment.
 7. Dust control shall be implemented as necessary during construction in accordance with dust (wind erosion) control Bmp 4-08.
 8. All trash containers are required to be covered at all times.
 9. Additional SWPPP BMPs shall be implemented as dictated by site conditions and as recommended by the QSP to prevent erosion and pollutant transport.

Z:\Projects\SDGE CNF_ESR\PMX\DelPana\SWPPP\BMP_Detailed_Route_v3.mxd

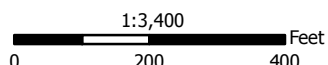

Site Map
TL625B Map 6 of 10

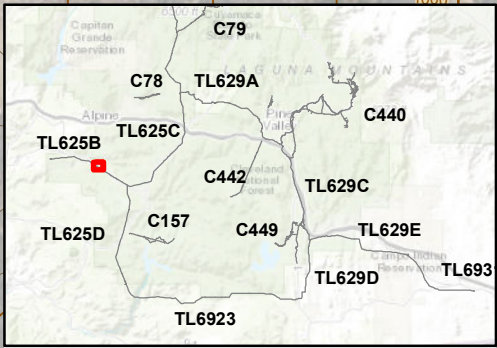
SDG&E MSUP and PTC
Power Line Replacement Projects

- LUP TYPE I PROJECT**
- Wood-to-Steel Replacement Pole
 - Removal Pole
 - Tie Line (TL)
 - Stringing Site
 - Access Road
 - Stream
 - Flow Direction
 - 100-ft Contour Interval
 - 20-ft Contour Interval
 - Preservation of Vegetation (BMP 4-01)
 - Fiber Roll (BMP 1-03)

- SWPPP Notes:
- Locations of SWPPP BMPs are not to scale.
 - SWPPP BMP locations are conceptual in nature and must be field-verified prior to construction.
 - Erosion and sediment controls shall be deployed prior to pavement or soil disturbance (where applicable) and as recommended by the QSP.
 - SDG&E BMP Details for sediment controls, erosion controls, waste management controls, and non-storm water discharge controls are contained within Appendix XI Construction BMPs of the Project SWPPP.
 - Preserve existing vegetation within all designated construction areas in accordance with BMP 4-01.
 - Track-out shall be removed at the end of every business day and as frequently as necessary to keep adjacent roads clean and free of sediment.
 - Dust control shall be implemented as necessary during construction in accordance with dust (wind erosion) control Bmp 4-08.
 - All trash containers are required to be covered at all times.
 - Additional SWPPP BMPs shall be implemented as dictated by site conditions and as recommended by the QSP to prevent erosion and pollutant transport.

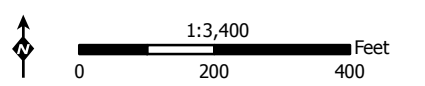



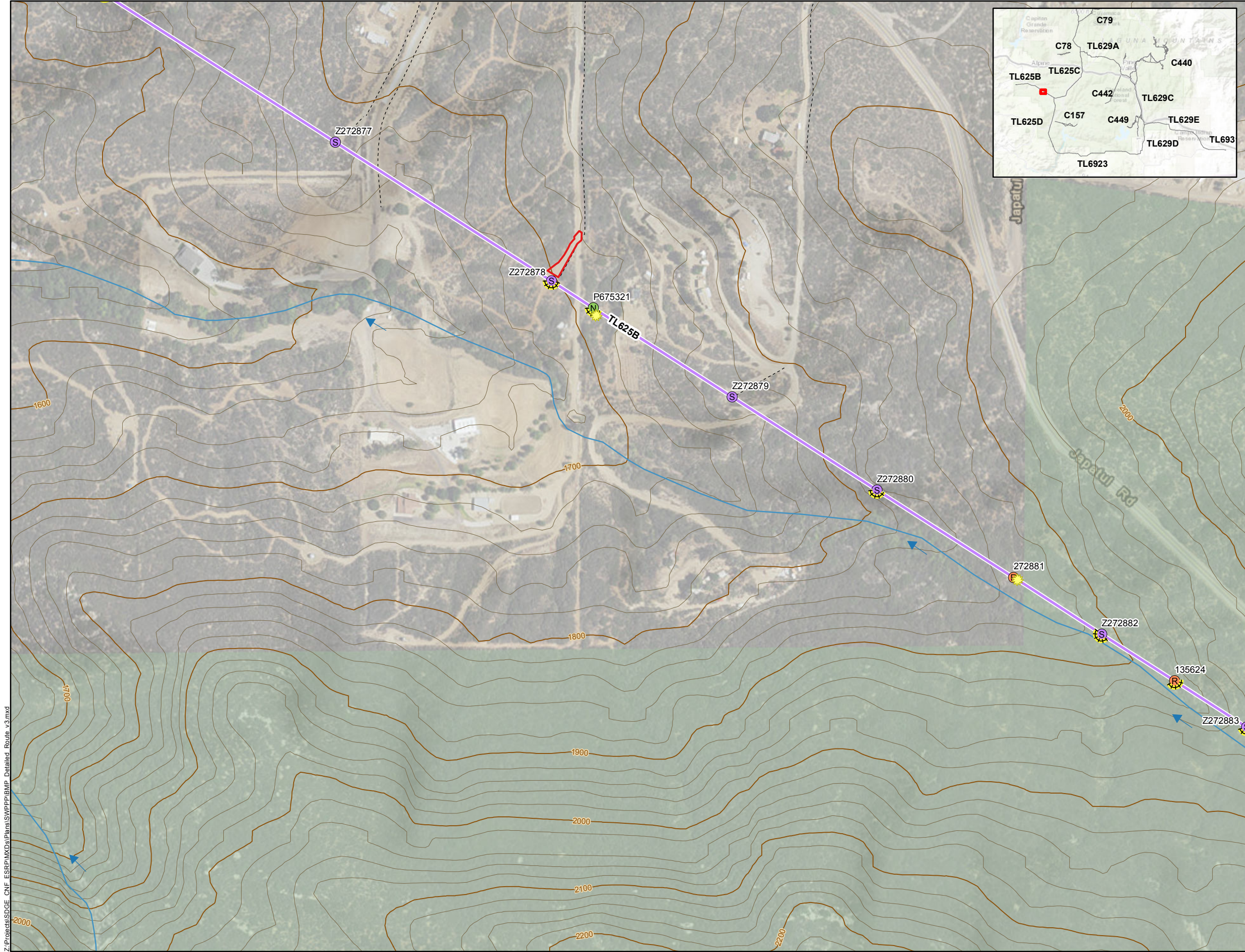









Z:\Projects\SDG&E CNF_ESRP\MapData\SWPPP\BMP_Detailed_Route_v3.mxd





Site Map
TL625B Map 7 of 10

SDG&E MSUP and PTC
Power Line Replacement Projects

- LUP TYPE I PROJECT**
-  New Steel Pole
 -  Wood-to-Steel Replacement Pole
 -  Removal Pole
 -  Tie Line (TL)
 -  Stringing Site
 -  Access Road
 -  Stream
 -  Flow Direction
 -  100-ft Contour Interval
 -  20-ft Contour Interval
 -  United States Forest Service
 -  Preservation of Vegetation (BMP 4-01)
 -  Fiber Roll (BMP 1-03)

- SWPPP Notes:
1. Locations of SWPPP BMPs are not to scale.
 2. SWPPP BMP locations are conceptual in nature and must be field-verified prior to construction.
 3. Erosion and sediment controls shall be deployed prior to pavement or soil disturbance (where applicable) and as recommended by the QSP.
 4. SDG&E BMP Details for sediment controls, erosion controls, waste management controls, and non-storm water discharge controls are contained within Appendix XI Construction BMPs of the Project SWPPP.
 5. Preserve existing vegetation within all designated construction areas in accordance with BMP 4-01.
 6. Track-out shall be removed at the end of every business day and as frequently as necessary to keep adjacent roads clean and free of sediment.
 7. Dust control shall be implemented as necessary during construction in accordance with dust (wind erosion) control Bmp 4-08.
 8. All trash containers are required to be covered at all times.
 9. Additional SWPPP BMPs shall be implemented as dictated by site conditions and as recommended by the QSP to prevent erosion and pollutant transport.

Z:\Projects\SDGE_CNF_ESRP\MapData\SWPPP\BMP_Detailed_Route_v3.mxd

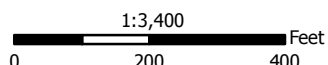
Z:\Projects\SDGE_CNF_ESRP\MapData\SWPPP\BMP_Detailed_Route_v3.mxd



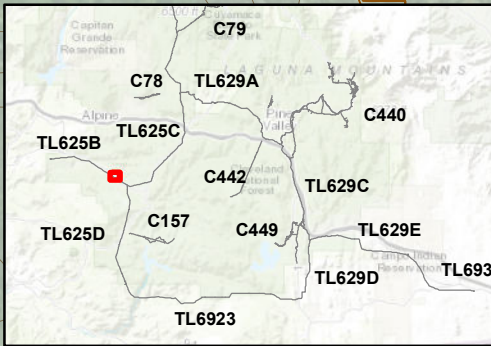

Site Map TL625B Map 8 of 10

SDG&E MSUP and PTC Power Line Replacement Projects

- #### LUP TYPE I PROJECT
- Wood-to-Steel Replacement Pole
 - Removal Pole
 - Tie Line (TL)
 - Staging Area
 - Access Road
 - Stream
 - Flow Direction
 - 100-ft Contour Interval
 - 20-ft Contour Interval
 - United States Forest Service
 - Material Delivery and Storage (BMP 2-01)
 - Secondary Containment Required (BMP 2-03)
 - Preservation of Vegetation (BMP 4-01)
 - Fiber Roll (BMP 1-03)
 - Silt Fence (BMP 1-02)

- SWPPP Notes:
1. Locations of SWPPP BMPs are not to scale.
 2. SWPPP BMP locations are conceptual in nature and must be field-verified prior to construction.
 3. Erosion and sediment controls shall be deployed prior to pavement or soil disturbance (where applicable) and as recommended by the QSP.
 4. SDG&E BMP Details for sediment controls, erosion controls, waste management controls, and non-storm water discharge controls are contained within Appendix XI Construction BMPs of the Project SWPPP.
 5. Preserve existing vegetation within all designated construction areas in accordance with BMP 4-01.
 6. Track-out shall be removed at the end of every business day and as frequently as necessary to keep adjacent roads clean and free of sediment.
 7. Dust control shall be implemented as necessary during construction in accordance with dust (wind erosion) control Bmp 4-08.
 8. All trash containers are required to be covered at all times.
 9. Additional SWPPP BMPs shall be implemented as dictated by site conditions and as recommended by the QSP to prevent erosion and pollutant transport.

Scale: 1:3,400 Feet

0 200 400

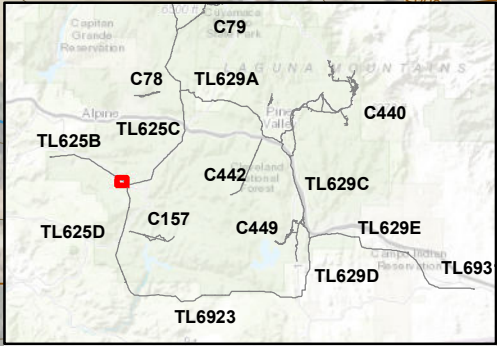
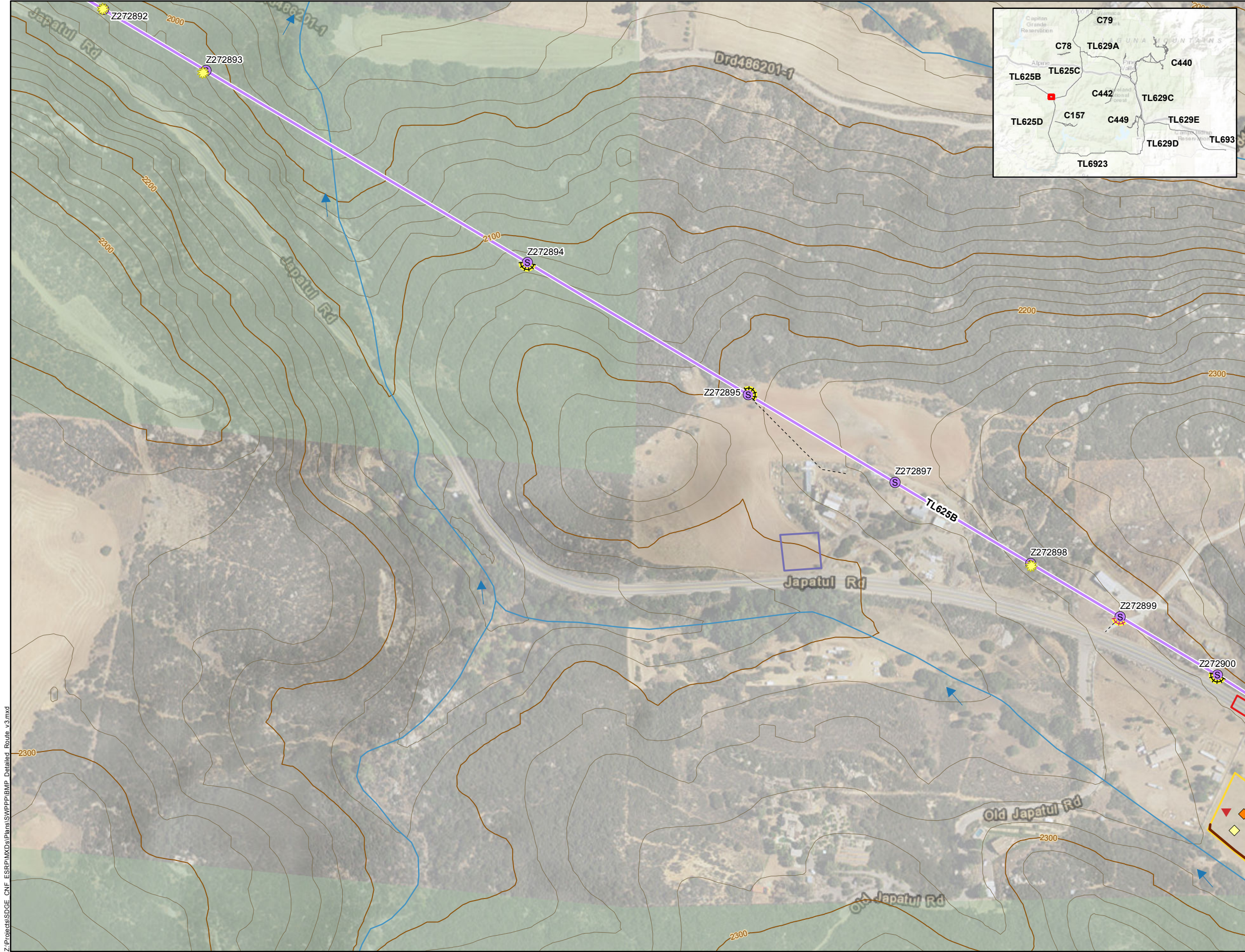

Site Map
TL625B Map 9 of 10

SDG&E MSUP and PTC
Power Line Replacement Projects

- LUP TYPE I PROJECT**
- Wood-to-Steel Replacement Pole
 - Tie Line (TL)
 - Fly Yard and Staging Area
 - Staging Area
 - Stringing Site
 - Access Road
 - Stream
 - Flow Direction
 - 100-ft Contour Interval
 - 20-ft Contour Interval
 - United States Forest Service
 - Sanitary/Septic Waste Management (BMP 2-07)
 - Material Delivery and Storage (BMP 2-01)
 - Secondary Containment Required (BMP 2-03)
 - Preservation of Vegetation (BMP 4-01)
 - Fiber Roll (BMP 1-03)
 - Gravel Bag Berm (BMP 1-04)
 - Silt Fence (BMP 1-02)

- SWPPP Notes:**
1. Locations of SWPPP BMPs are not to scale.
 2. SWPPP BMP locations are conceptual in nature and must be field-verified prior to construction.
 3. Erosion and sediment controls shall be deployed prior to pavement or soil disturbance (where applicable) and as recommended by the QSP.
 4. SDG&E BMP Details for sediment controls, erosion controls, waste management controls, and non-storm water discharge controls are contained within Appendix XI Construction BMPs of the Project SWPPP.
 5. Preserve existing vegetation within all designated construction areas in accordance with BMP 4-01.
 6. Track-out shall be removed at the end of every business day and as frequently as necessary to keep adjacent roads clean and free of sediment.
 7. Dust control shall be implemented as necessary during construction in accordance with dust (wind erosion) control Bmp 4-08.
 8. All trash containers are required to be covered at all times.
 9. Additional SWPPP BMPs shall be implemented as dictated by site conditions and as recommended by the QSP to prevent erosion and pollutant transport.

1:3,400

0 200 400 Feet

Z:\Projects\SDGE_CNF_ESR\MapData\Plans\SWPPP\BMP_Detailed_Route_v3.mxd

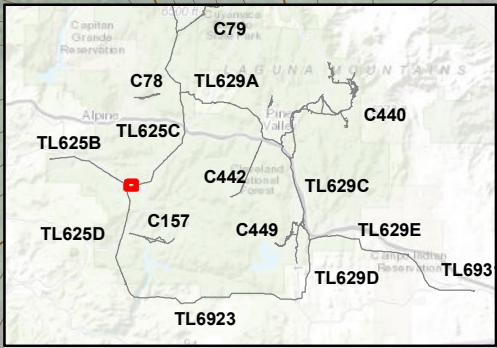
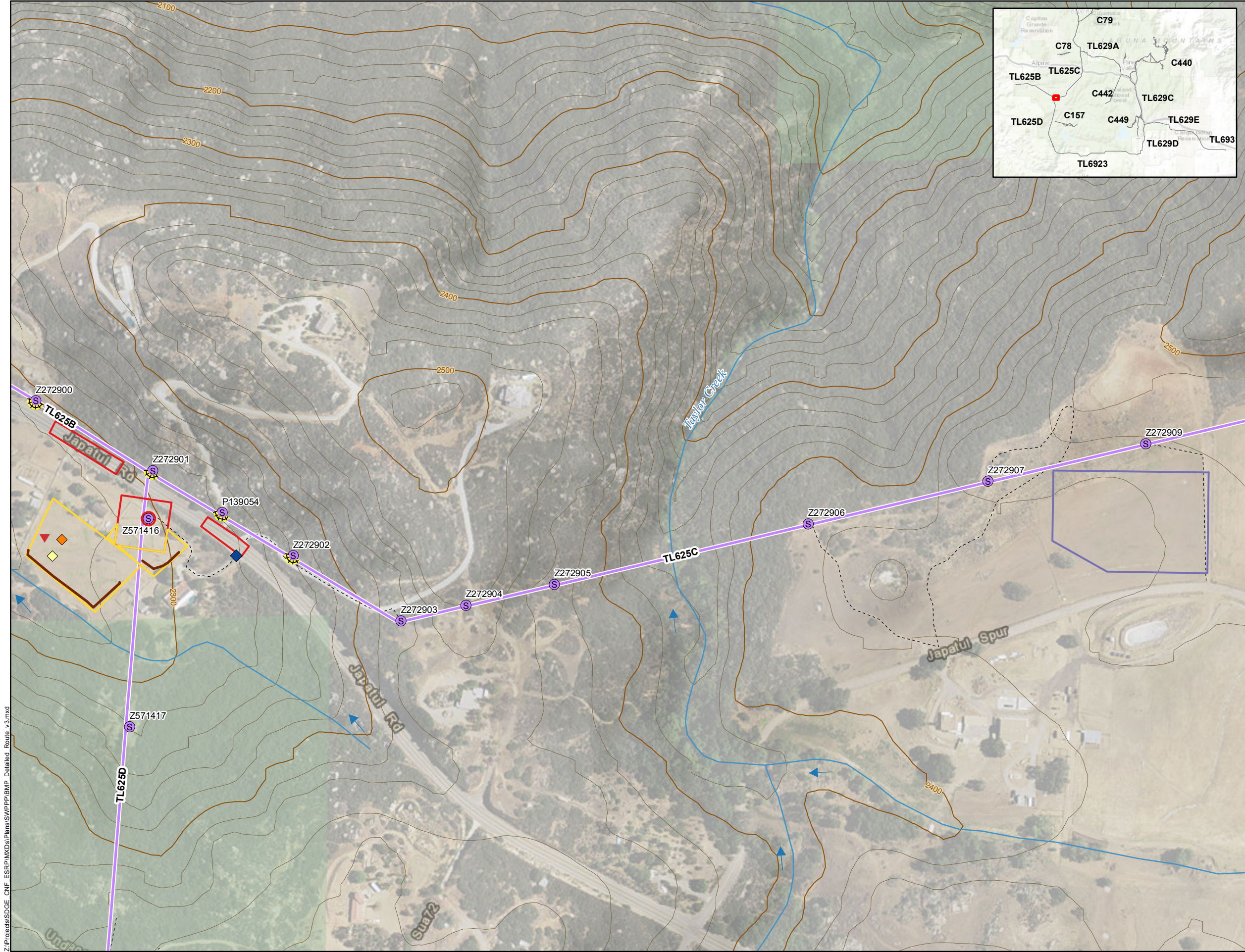

Site Map
TL625B Map 10 of 10

SDG&E MSUP and PTC
Power Line Replacement Projects

- LUP TYPE I PROJECT**
- Wood-to-Steel Replacement Pole
 - Tie Line (TL)
 - Fly Yard and Staging Area
 - Staging Area
 - Stringing Site
 - Access Road
 - Stream
 - Flow Direction
 - 100-ft Contour Interval
 - 20-ft Contour Interval
 - United States Forest Service
 - Sanitary/Septic Waste Management (BMP 2-07)
 - Material Delivery and Storage (BMP 2-01)
 - Secondary Containment Required (BMP 2-03)
 - Tracking Control (BMP-1-07)
 - Fiber Roll (BMP 1-03)
 - Silt Fence (BMP 1-02)

- SWPPP Notes:**
1. Locations of SWPPP BMPs are not to scale.
 2. SWPPP BMP locations are conceptual in nature and must be field-verified prior to construction.
 3. Erosion and sediment controls shall be deployed prior to pavement or soil disturbance (where applicable) and as recommended by the QSP.
 4. SDG&E BMP Details for sediment controls, erosion controls, waste management controls, and non-storm water discharge controls are contained within Appendix XI Construction BMPs of the Project SWPPP.
 5. Preserve existing vegetation within all designated construction areas in accordance with BMP 4-01.
 6. Track-out shall be removed at the end of every business day and as frequently as necessary to keep adjacent roads clean and free of sediment.
 7. Dust control shall be implemented as necessary during construction in accordance with dust (wind erosion) control Bmp 4-08.
 8. All trash containers are required to be covered at all times.
 9. Additional SWPPP BMPs shall be implemented as dictated by site conditions and as recommended by the QSP to prevent erosion and pollutant transport.

1:3,400

Z:\Projects\SDGE_CNF_ESR\MapData\Plan\SWPPP\BMP_Detailed_Route_v3.mxd

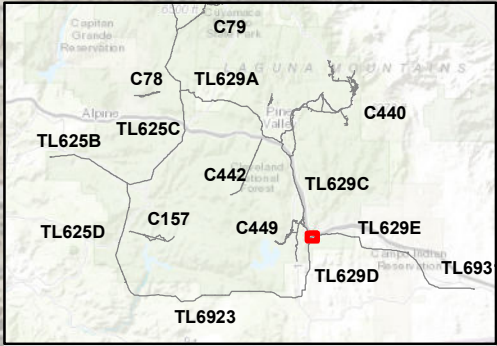
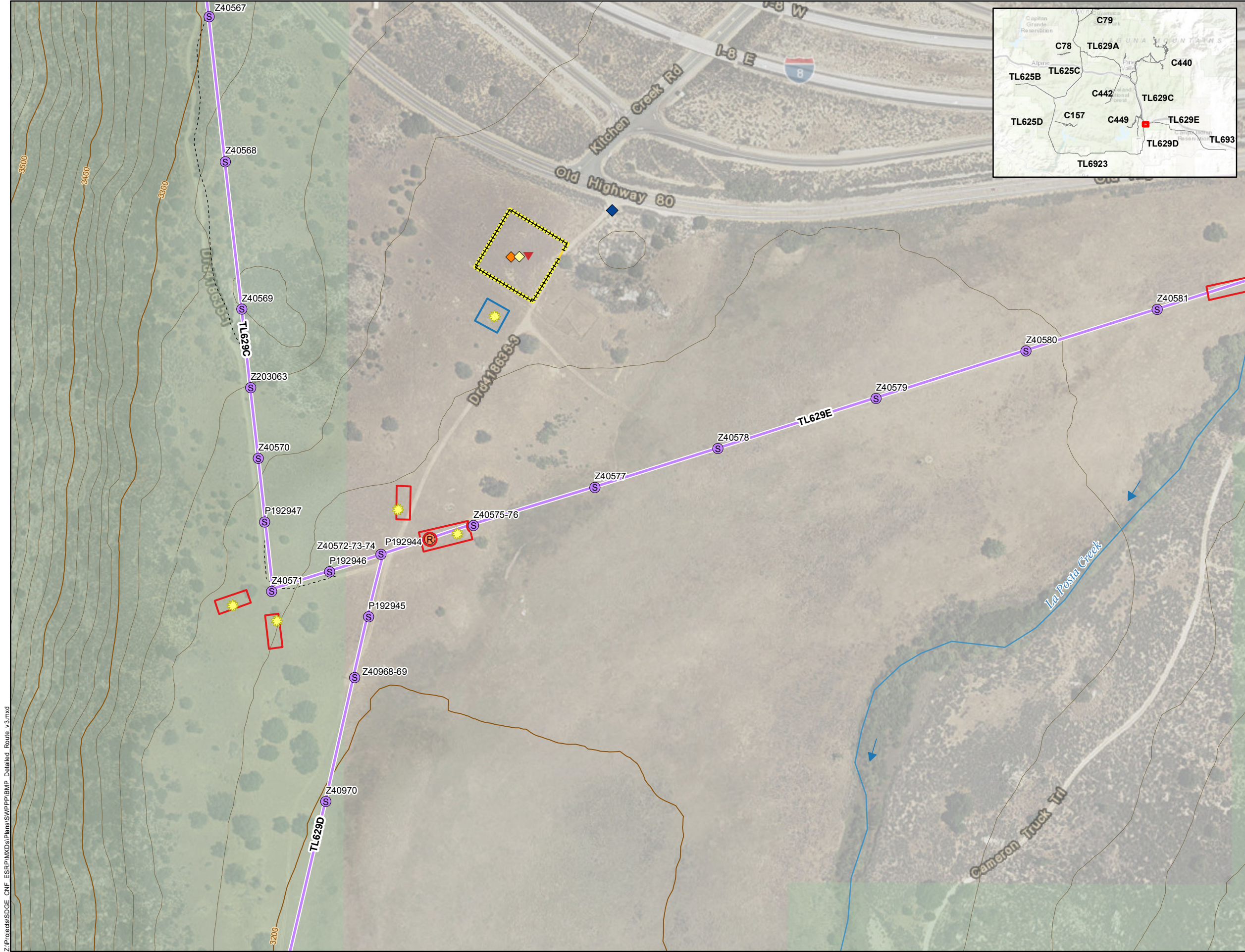

Site Map
TL629E Map 1 of 12

SDG&E MSUP and PTC
Power Line Replacement Projects

- LUP TYPE I PROJECT**
- Wood-to-Steel Replacement Pole
 - Removal Pole
 - Tie Line (TL)
 - Fly Yard
 - Staging Area
 - Stringing Site
 - Access Road
 - Stream
 - Flow Direction
 - 100-ft Contour Interval
 - 20-ft Contour Interval
 - United States Forest Service
 - Sanitary/Septic Waste Management (BMP 2-07)
 - Material Delivery and Storage (BMP 2-01)
 - Secondary Containment Required (BMP 2-03)
 - Preservation of Vegetation (BMP 4-01)
 - Tracking Control (BMP-1-07)
 - Fiber Roll (BMP 1-03)

- SWPPP Notes:**
1. Locations of SWPPP BMPs are not to scale.
 2. SWPPP BMP locations are conceptual in nature and must be field-verified prior to construction.
 3. Erosion and sediment controls shall be deployed prior to pavement or soil disturbance (where applicable) and as recommended by the QSP.
 4. SDG&E BMP Details for sediment controls, erosion controls, waste management controls, and non-storm water discharge controls are contained within Appendix XI Construction BMPs of the Project SWPPP.
 5. Preserve existing vegetation within all designated construction areas in accordance with BMP 4-01.
 6. Track-out shall be removed at the end of every business day and as frequently as necessary to keep adjacent roads clean and free of sediment.
 7. Dust control shall be implemented as necessary during construction in accordance with dust (wind erosion) control Bmp 4-08.
 8. All trash containers are required to be covered at all times.
 9. Additional SWPPP BMPs shall be implemented as dictated by site conditions and as recommended by the QSP to prevent erosion and pollutant transport.

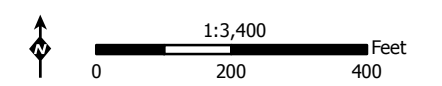

Z:\Projects\SDG&E_CNF_ESR\PM\DelPana\SWPPP\BMP_Detailed_Route_v3.mxd

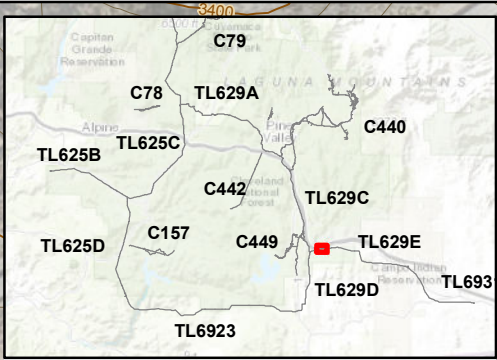
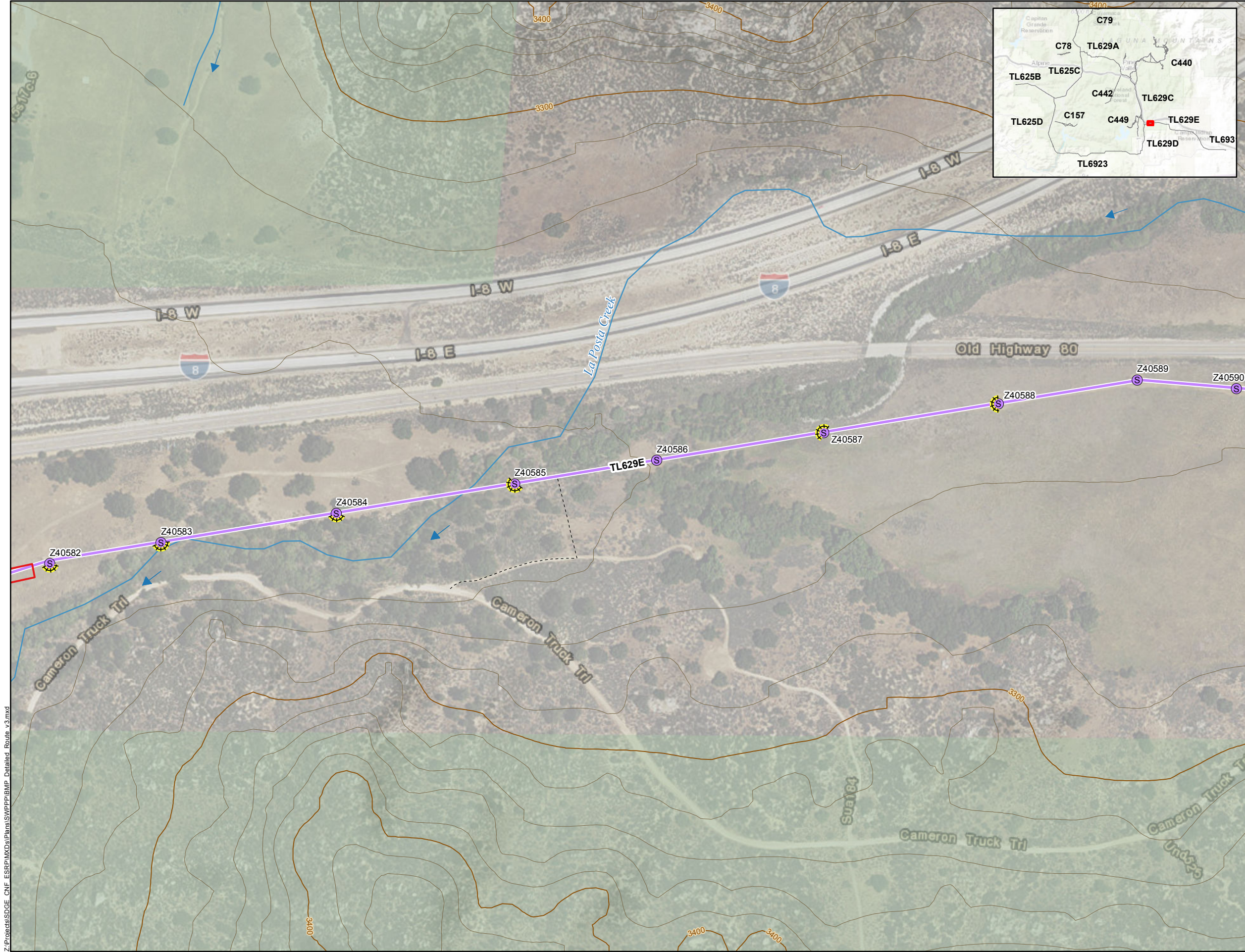

Site Map
TL629E Map 2 of 12

SDG&E MSUP and PTC
Power Line Replacement Projects

- LUP TYPE I PROJECT**
- Wood-to-Steel Replacement Pole
 - Tie Line (TL)
 - Stringing Site
 - Access Road
 - Stream
 - Flow Direction
 - 100-ft Contour Interval
 - 20-ft Contour Interval
 - United States Forest Service
 - Fiber Roll (BMP 1-03)

- SWPPP Notes:**
1. Locations of SWPPP BMPs are not to scale.
 2. SWPPP BMP locations are conceptual in nature and must be field-verified prior to construction.
 3. Erosion and sediment controls shall be deployed prior to pavement or soil disturbance (where applicable) and as recommended by the QSP.
 4. SDG&E BMP Details for sediment controls, erosion controls, waste management controls, and non-storm water discharge controls are contained within Appendix XI Construction BMPs of the Project SWPPP.
 5. Preserve existing vegetation within all designated construction areas in accordance with BMP 4-01.
 6. Track-out shall be removed at the end of every business day and as frequently as necessary to keep adjacent roads clean and free of sediment.
 7. Dust control shall be implemented as necessary during construction in accordance with dust (wind erosion) control Bmp 4-08.
 8. All trash containers are required to be covered at all times.
 9. Additional SWPPP BMPs shall be implemented as dictated by site conditions and as recommended by the QSP to prevent erosion and pollutant transport.

1:3,400

0 200 400 Feet

Z:\Projects\SDGE_CNF_ESR\PM\Drawings\SWPPP\BMP_Detailed_Route_v3.mxd

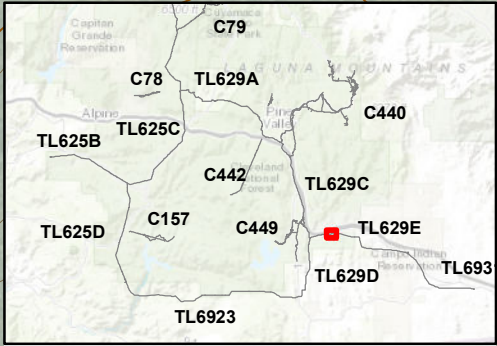
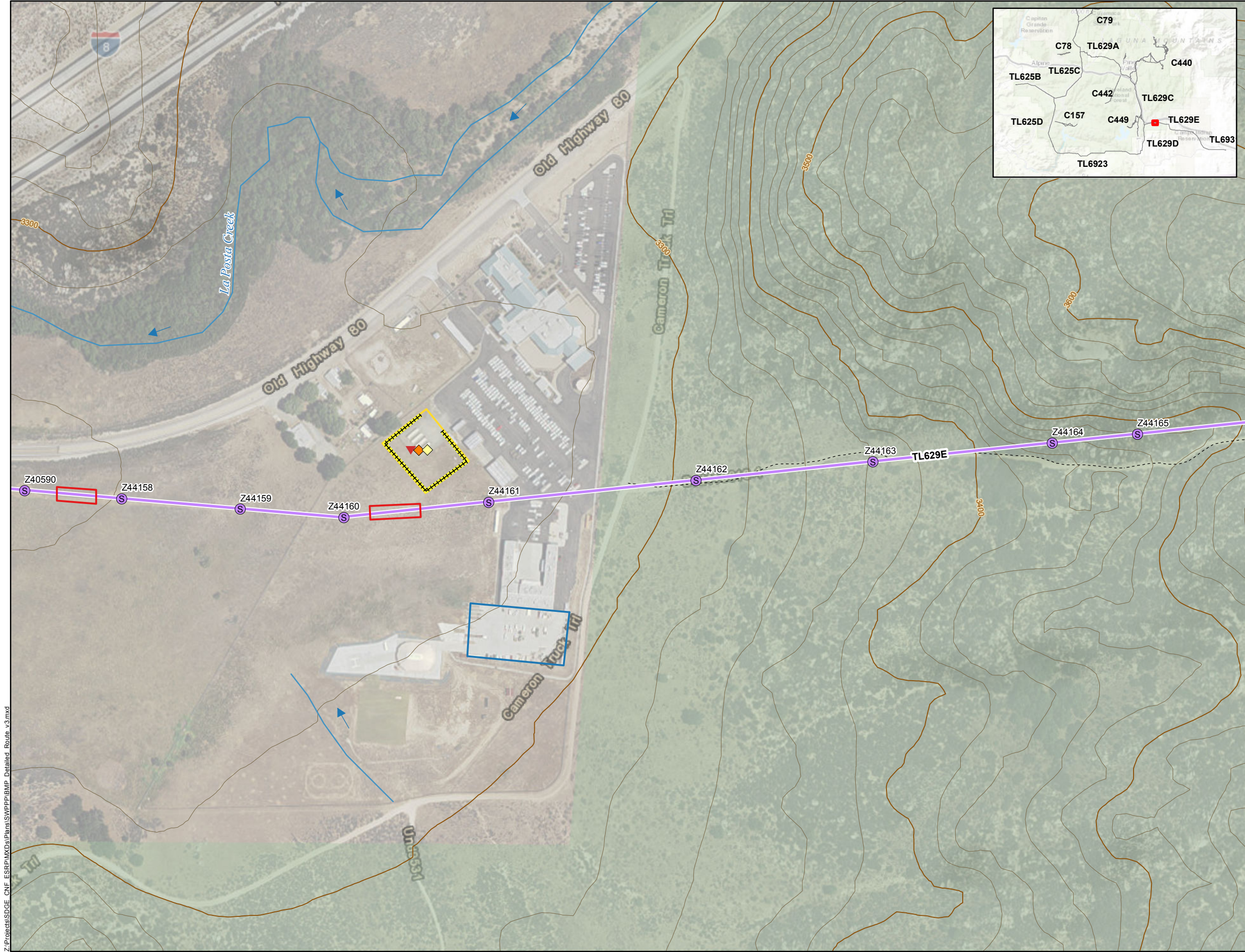

Site Map
TL629E Map 3 of 12

SDG&E MSUP and PTC
Power Line Replacement Projects

- LUP TYPE I PROJECT**
- Wood-to-Steel Replacement Pole
 - Tie Line (TL)
 - Fly Yard
 - Staging Area
 - Stringing Site
 - Access Road
 - Stream
 - Flow Direction
 - 100-ft Contour Interval
 - 20-ft Contour Interval
 - United States Forest Service
 - Sanitary/Septic Waste Management (BMP 2-07)
 - Material Delivery and Storage (BMP 2-01)
 - Secondary Containment Required (BMP 2-03)
 - Fiber Roll (BMP 1-03)

- SWPPP Notes:
1. Locations of SWPPP BMPs are not to scale.
 2. SWPPP BMP locations are conceptual in nature and must be field-verified prior to construction.
 3. Erosion and sediment controls shall be deployed prior to pavement or soil disturbance (where applicable) and as recommended by the QSP.
 4. SDG&E BMP Details for sediment controls, erosion controls, waste management controls, and non-storm water discharge controls are contained within Appendix XI Construction BMPs of the Project SWPPP.
 5. Preserve existing vegetation within all designated construction areas in accordance with BMP 4-01.
 6. Track-out shall be removed at the end of every business day and as frequently as necessary to keep adjacent roads clean and free of sediment.
 7. Dust control shall be implemented as necessary during construction in accordance with dust (wind erosion) control Bmp 4-08.
 8. All trash containers are required to be covered at all times.
 9. Additional SWPPP BMPs shall be implemented as dictated by site conditions and as recommended by the QSP to prevent erosion and pollutant transport.

1:3,400

0 200 400 Feet

Z:\Projects\SDGE_CNF_ESRP\MapData\SWPPP\BMP_Detailed_Route_v3.mxd

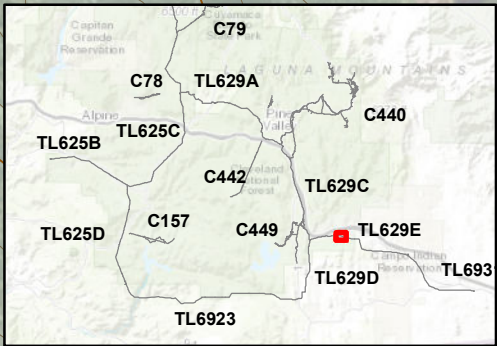

Site Map
TL629E Map 4 of 12

SDG&E MSUP and PTC
Power Line Replacement Projects

- LUP TYPE I PROJECT**
- Wood-to-Steel Replacement Pole
 - Tie Line (TL)
 - Stringing Site
 - Access Road
 - Stream
 - Flow Direction
 - 100-ft Contour Interval
 - 20-ft Contour Interval
 - United States Forest Service
 - Fiber Roll (BMP 1-03)

- SWPPP Notes:
1. Locations of SWPPP BMPs are not to scale.
 2. SWPPP BMP locations are conceptual in nature and must be field-verified prior to construction.
 3. Erosion and sediment controls shall be deployed prior to pavement or soil disturbance (where applicable) and as recommended by the QSP.
 4. SDG&E BMP Details for sediment controls, erosion controls, waste management controls, and non-storm water discharge controls are contained within Appendix XI Construction BMPs of the Project SWPPP.
 5. Preserve existing vegetation within all designated construction areas in accordance with BMP 4-01.
 6. Track-out shall be removed at the end of every business day and as frequently as necessary to keep adjacent roads clean and free of sediment.
 7. Dust control shall be implemented as necessary during construction in accordance with dust (wind erosion) control Bmp 4-08.
 8. All trash containers are required to be covered at all times.
 9. Additional SWPPP BMPs shall be implemented as dictated by site conditions and as recommended by the QSP to prevent erosion and pollutant transport.

Z:\Projects\SDGE_CNF_ESRP\MapData\SWPPP\BMP_Detailed_Route_v3.mxd

Z:\Projects\SDGE_CNF_ESRP\MapData\Plans\SWPPP\BMP_Detailed_Route_v3.mxd

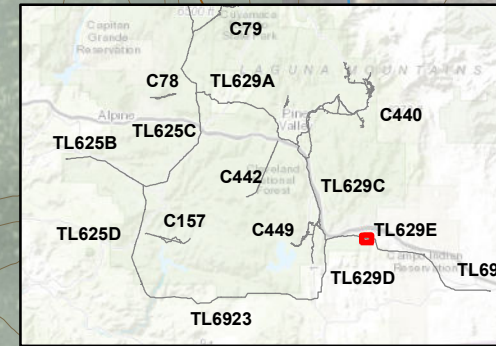

Site Map TL629E Map 5 of 12

SDG&E MSUP and PTC Power Line Replacement Projects

LUP TYPE I PROJECT

- Wood-to-Steel Replacement Pole
- Tie Line (TL)
- Stringing Site
- Access Road
- Stream
- Flow Direction
- 100-ft Contour Interval
- 20-ft Contour Interval
- United States Forest Service
- Tracking Control (BMP-1-07)
- Fiber Roll (BMP 1-03)

- SWPPP Notes:
1. Locations of SWPPP BMPs are not to scale.
 2. SWPPP BMP locations are conceptual in nature and must be field-verified prior to construction.
 3. Erosion and sediment controls shall be deployed prior to pavement or soil disturbance (where applicable) and as recommended by the QSP.
 4. SDG&E BMP Details for sediment controls, erosion controls, waste management controls, and non-storm water discharge controls are contained within Appendix XI Construction BMPs of the Project SWPPP.
 5. Preserve existing vegetation within all designated construction areas in accordance with BMP 4-01.
 6. Track-out shall be removed at the end of every business day and as frequently as necessary to keep adjacent roads clean and free of sediment.
 7. Dust control shall be implemented as necessary during construction in accordance with dust (wind erosion) control Bmp 4-08.
 8. All trash containers are required to be covered at all times.
 9. Additional SWPPP BMPs shall be implemented as dictated by site conditions and as recommended by the QSP to prevent erosion and pollutant transport.

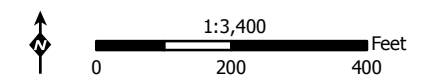

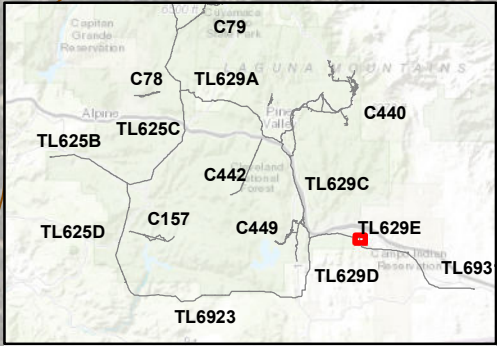

Site Map
TL629E Map 6 of 12

SDG&E MSUP and PTC
Power Line Replacement Projects

- LUP TYPE I PROJECT**
- Wood-to-Steel Replacement Pole
 - Tie Line (TL)
 - Stringing Site
 - Access Road
 - Stream
 - Flow Direction
 - 100-ft Contour Interval
 - 20-ft Contour Interval
 - U.S. Bureau of Land Management
 - Fiber Roll (BMP 1-03)

- SWPPP Notes:**
1. Locations of SWPPP BMPs are not to scale.
 2. SWPPP BMP locations are conceptual in nature and must be field-verified prior to construction.
 3. Erosion and sediment controls shall be deployed prior to pavement or soil disturbance (where applicable) and as recommended by the QSP.
 4. SDG&E BMP Details for sediment controls, erosion controls, waste management controls, and non-storm water discharge controls are contained within Appendix XI Construction BMPs of the Project SWPPP.
 5. Preserve existing vegetation within all designated construction areas in accordance with BMP 4-01.
 6. Track-out shall be removed at the end of every business day and as frequently as necessary to keep adjacent roads clean and free of sediment.
 7. Dust control shall be implemented as necessary during construction in accordance with dust (wind erosion) control Bmp 4-08.
 8. All trash containers are required to be covered at all times.
 9. Additional SWPPP BMPs shall be implemented as dictated by site conditions and as recommended by the QSP to prevent erosion and pollutant transport.

1:3,400

0 200 400 Feet

Z:\Projects\SDGE CNF_ESRPMX\DelPana\SWPPP\BMP_Detailed_Route_v3.mxd

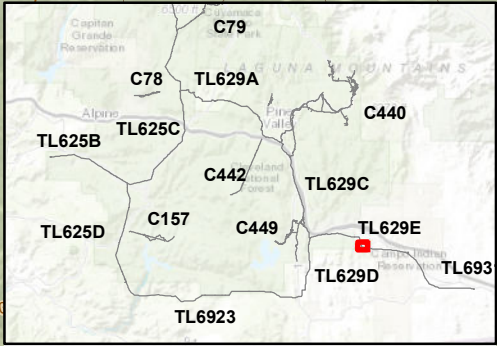

Site Map
TL629E Map 7 of 12

SDG&E MSUP and PTC
Power Line Replacement Projects

- LUP TYPE I PROJECT**
- Wood-to-Steel Replacement Pole
 - Tie Line (TL)
 - Stringing Site
 - Access Road
 - Stream
 - Flow Direction
 - 100-ft Contour Interval
 - 20-ft Contour Interval
 - U.S. Bureau of Land Management
 - Fiber Roll (BMP 1-03)

- SWPPP Notes:
1. Locations of SWPPP BMPs are not to scale.
 2. SWPPP BMP locations are conceptual in nature and must be field-verified prior to construction.
 3. Erosion and sediment controls shall be deployed prior to pavement or soil disturbance (where applicable) and as recommended by the QSP.
 4. SDG&E BMP Details for sediment controls, erosion controls, waste management controls, and non-storm water discharge controls are contained within Appendix XI Construction BMPs of the Project SWPPP.
 5. Preserve existing vegetation within all designated construction areas in accordance with BMP 4-01.
 6. Track-out shall be removed at the end of every business day and as frequently as necessary to keep adjacent roads clean and free of sediment.
 7. Dust control shall be implemented as necessary during construction in accordance with dust (wind erosion) control Bmp 4-08.
 8. All trash containers are required to be covered at all times.
 9. Additional SWPPP BMPs shall be implemented as dictated by site conditions and as recommended by the QSP to prevent erosion and pollutant transport.

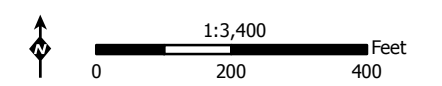

Z:\Projects\SDG&E CNF_ESRP\MapData\BMP_Detailed_Route_v3.mxd

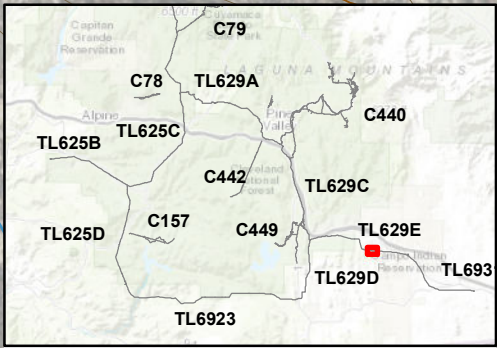
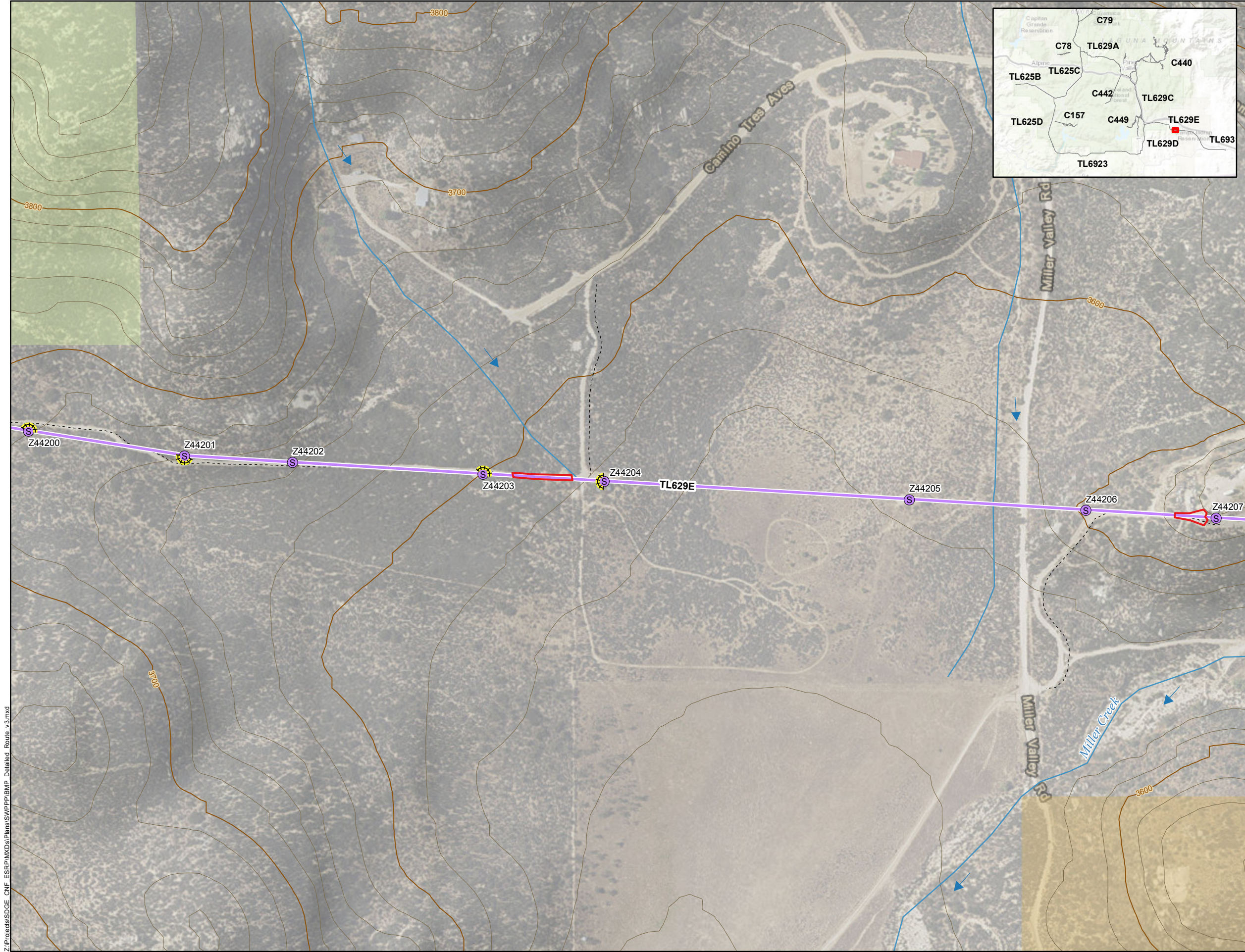

Site Map
TL629E Map 8 of 12

SDG&E MSUP and PTC
Power Line Replacement Projects

- LUP TYPE I PROJECT**
- Wood-to-Steel Replacement Pole
 - Tie Line (TL)
 - Stringing Site
 - Access Road
 - Stream
 - Flow Direction
 - 100-ft Contour Interval
 - 20-ft Contour Interval
 - U.S. Bureau of Land Management
 - Bureau of Indian Affairs Land
 - Fiber Roll (BMP 1-03)

- SWPPP Notes:**
- Locations of SWPPP BMPs are not to scale.
 - SWPPP BMP locations are conceptual in nature and must be field-verified prior to construction.
 - Erosion and sediment controls shall be deployed prior to pavement or soil disturbance (where applicable) and as recommended by the QSP.
 - SDG&E BMP Details for sediment controls, erosion controls, waste management controls, and non-storm water discharge controls are contained within Appendix XI Construction BMPs of the Project SWPPP.
 - Preserve existing vegetation within all designated construction areas in accordance with BMP 4-01.
 - Track-out shall be removed at the end of every business day and as frequently as necessary to keep adjacent roads clean and free of sediment.
 - Dust control shall be implemented as necessary during construction in accordance with dust (wind erosion) control Bmp 4-08.
 - All trash containers are required to be covered at all times.
 - Additional SWPPP BMPs shall be implemented as dictated by site conditions and as recommended by the QSP to prevent erosion and pollutant transport.

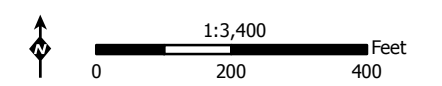

Z:\Projects\SDGE_CNF_ESRP\MapData\SWPPP\BMP_Detailed_Route_v3.mxd

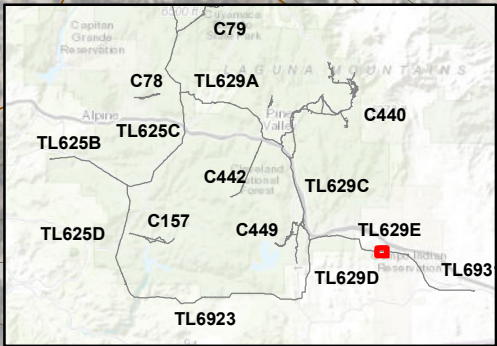
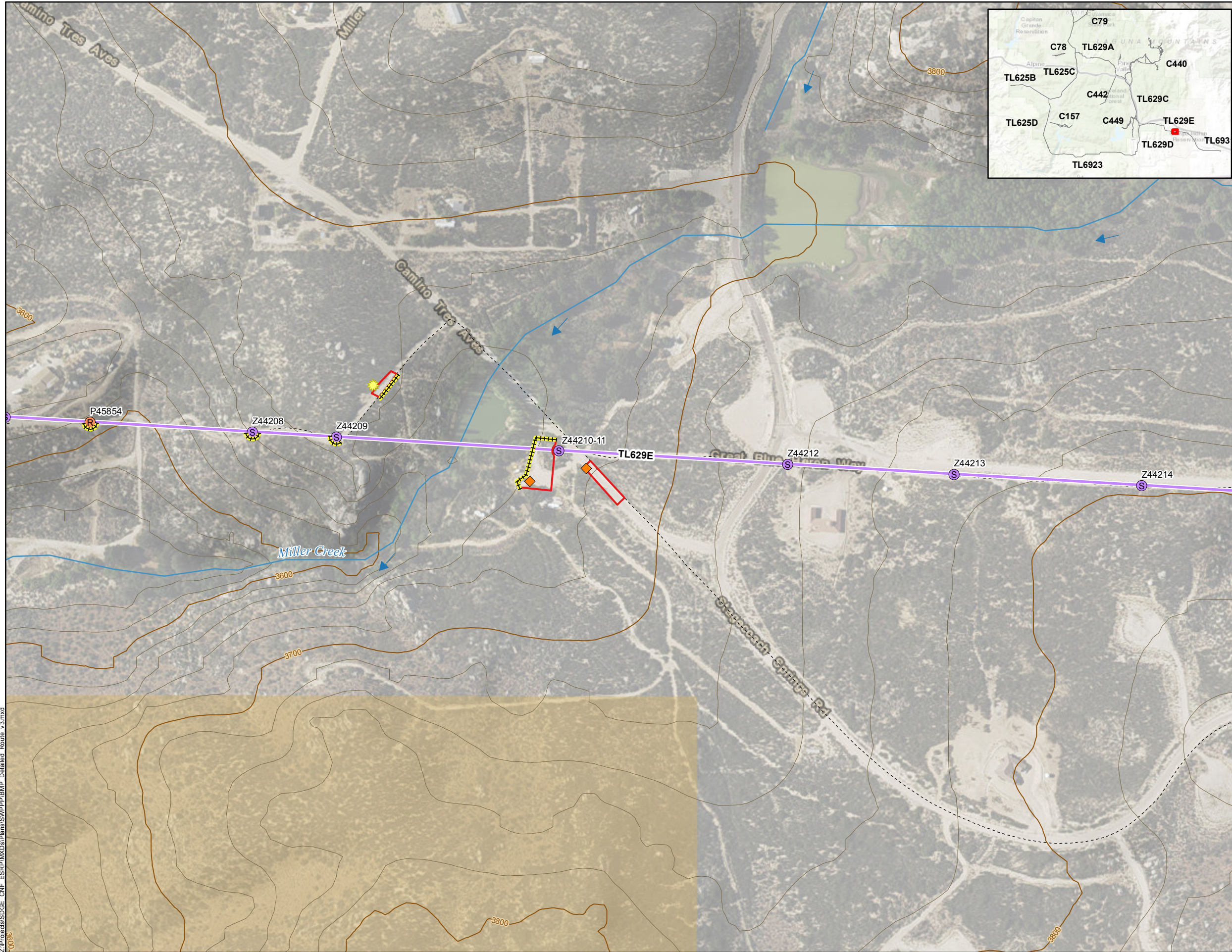

Site Map
TL629E Map 9 of 12

SDG&E MSUP and PTC
Power Line Replacement Projects

- LUP TYPE I PROJECT**
- Wood-to-Steel Replacement Pole
 - Removal Pole
 - Tie Line (TL)
 - Stringing Site
 - Access Road
 - Stream
 - Flow Direction
 - 100-ft Contour Interval
 - 20-ft Contour Interval
 - Bureau of Indian Affairs Land
 - Material Delivery and Storage (BMP 2-01)
 - Preservation of Vegetation (BMP 4-01)
 - Fiber Roll (BMP 1-03)

- SWPPP Notes:**
1. Locations of SWPPP BMPs are not to scale.
 2. SWPPP BMP locations are conceptual in nature and must be field-verified prior to construction.
 3. Erosion and sediment controls shall be deployed prior to pavement or soil disturbance (where applicable) and as recommended by the QSP.
 4. SDG&E BMP Details for sediment controls, erosion controls, waste management controls, and non-storm water discharge controls are contained within Appendix XI Construction BMPs of the Project SWPPP.
 5. Preserve existing vegetation within all designated construction areas in accordance with BMP 4-01.
 6. Track-out shall be removed at the end of every business day and as frequently as necessary to keep adjacent roads clean and free of sediment.
 7. Dust control shall be implemented as necessary during construction in accordance with dust (wind erosion) control Bmp 4-08.
 8. All trash containers are required to be covered at all times.
 9. Additional SWPPP BMPs shall be implemented as dictated by site conditions and as recommended by the QSP to prevent erosion and pollutant transport.





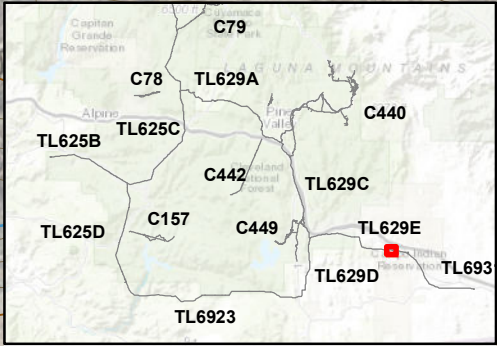







1:3,400
0 200 400 Feet

Z:\Projects\SDGE CNF_ESRP\MapData\BMP_Detailed_Route_v3.mxd





Site Map
TL629E Map 10 of 12

SDG&E MSUP and PTC
Power Line Replacement Projects

- LUP TYPE I PROJECT**
-  New Steel Pole
 -  Wood-to-Steel Replacement Pole
 -  Removal Pole
 -  Tie Line (TL)
 -  Stringing Site
 -  Access Road
 -  Stream
 -  Flow Direction
 -  100-ft Contour Interval
 -  20-ft Contour Interval
 -  Preservation of Vegetation (BMP 4-01)
 -  Fiber Roll (BMP 1-03)
 -  Gravel Bag Berm (BMP 1-04)

- SWPPP Notes:
- Locations of SWPPP BMPs are not to scale.
 - SWPPP BMP locations are conceptual in nature and must be field-verified prior to construction.
 - Erosion and sediment controls shall be deployed prior to pavement or soil disturbance (where applicable) and as recommended by the QSP.
 - SDG&E BMP Details for sediment controls, erosion controls, waste management controls, and non-storm water discharge controls are contained within Appendix XI Construction BMPs of the Project SWPPP.
 - Preserve existing vegetation within all designated construction areas in accordance with BMP 4-01.
 - Track-out shall be removed at the end of every business day and as frequently as necessary to keep adjacent roads clean and free of sediment.
 - Dust control shall be implemented as necessary during construction in accordance with dust (wind erosion) control Bmp 4-08.
 - All trash containers are required to be covered at all times.
 - Additional SWPPP BMPs shall be implemented as dictated by site conditions and as recommended by the QSP to prevent erosion and pollutant transport.



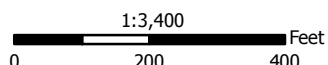



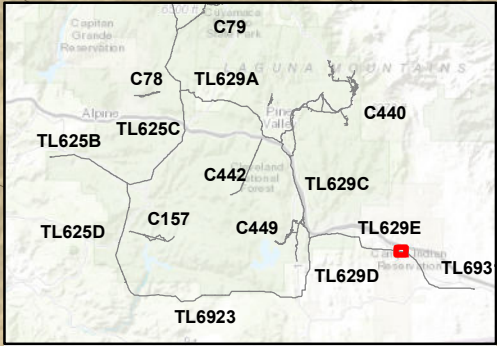





Z:\Projects\SDGE CNF_ESRP\MapData\SWPPP\BMP_Detailed_Route_v3.mxd



Site Map
TL629E Map 11 of 12

SDG&E MSUP and PTC
Power Line Replacement Projects

- LUP TYPE I PROJECT**
-  New Steel Pole
 -  Wood-to-Steel Replacement Pole
 -  Tie Line (TL)
 -  Access Road
 -  Stream
 -  Flow Direction
 -  100-ft Contour Interval
 -  20-ft Contour Interval
 -  Bureau of Indian Affairs Land
 -  Fiber Roll (BMP 1-03)

- SWPPP Notes:
1. Locations of SWPPP BMPs are not to scale.
 2. SWPPP BMP locations are conceptual in nature and must be field-verified prior to construction.
 3. Erosion and sediment controls shall be deployed prior to pavement or soil disturbance (where applicable) and as recommended by the QSP.
 4. SDG&E BMP Details for sediment controls, erosion controls, waste management controls, and non-storm water discharge controls are contained within Appendix XI Construction BMPs of the Project SWPPP.
 5. Preserve existing vegetation within all designated construction areas in accordance with BMP 4-01.
 6. Track-out shall be removed at the end of every business day and as frequently as necessary to keep adjacent roads clean and free of sediment.
 7. Dust control shall be implemented as necessary during construction in accordance with dust (wind erosion) control Bmp 4-08.
 8. All trash containers are required to be covered at all times.
 9. Additional SWPPP BMPs shall be implemented as dictated by site conditions and as recommended by the QSP to prevent erosion and pollutant transport.

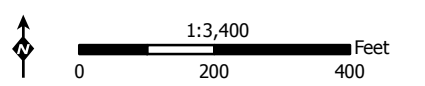

Z:\Projects\SDGE_CNF_ESR\PMX\DelPlan\SWPPP\BMP_Detailed_Route_v3.mxd

Z:\Projects\SD&E\CNF_ESRP\MapData\BMP_SWPPP\BMP_Detailed_Route_v3.mxd

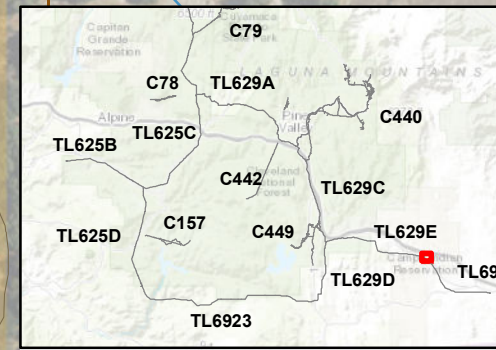
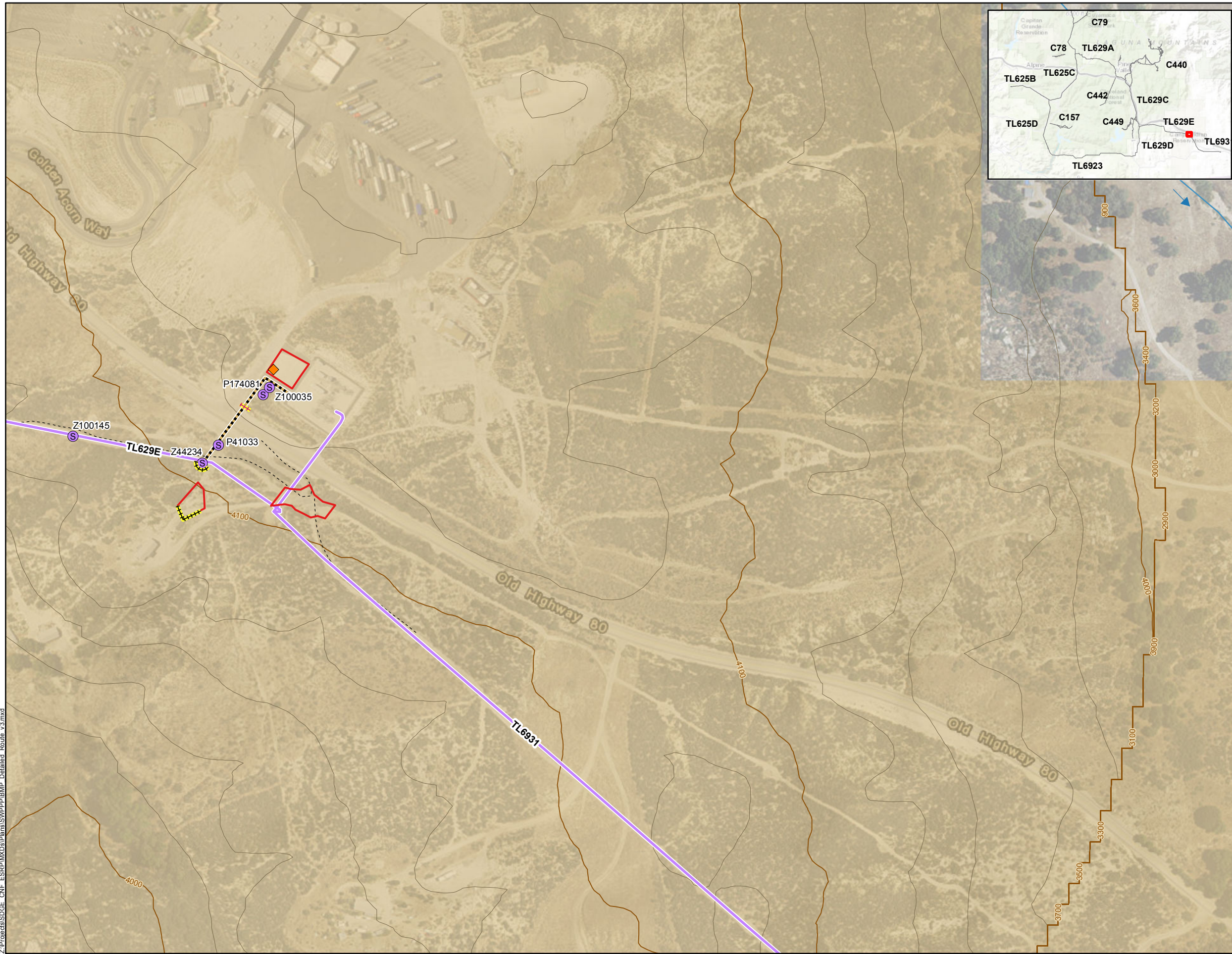

Site Map TL629E Map 12 of 12

SDG&E MSUP and PTC Power Line Replacement Projects

- #### LUP TYPE I PROJECT
- Wood-to-Steel Replacement Pole
 - Tie Line (TL)
 - Tie Line (TL) Undergrounding
 - Stringing Site
 - Access Road
 - Stream
 - Flow Direction
 - 100-ft Contour Interval
 - 20-ft Contour Interval
 - Bureau of Indian Affairs Land
 - Material Delivery and Storage (BMP 2-01)
 - Fiber Roll (BMP 1-03)
 - Gravel Bag Berm (BMP 1-04)

- SWPPP Notes:
1. Locations of SWPPP BMPs are not to scale.
 2. SWPPP BMP locations are conceptual in nature and must be field-verified prior to construction.
 3. Erosion and sediment controls shall be deployed prior to pavement or soil disturbance (where applicable) and as recommended by the QSP.
 4. SDG&E BMP Details for sediment controls, erosion controls, waste management controls, and non-storm water discharge controls are contained within Appendix XI Construction BMPs of the Project SWPPP.
 5. Preserve existing vegetation within all designated construction areas in accordance with BMP 4-01.
 6. Track-out shall be removed at the end of every business day and as frequently as necessary to keep adjacent roads clean and free of sediment.
 7. Dust control shall be implemented as necessary during construction in accordance with dust (wind erosion) control Bmp 4-08.
 8. All trash containers are required to be covered at all times.
 9. Additional SWPPP BMPs shall be implemented as dictated by site conditions and as recommended by the QSP to prevent erosion and pollutant transport.

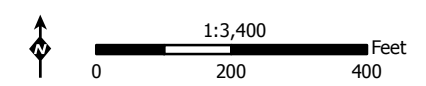

Z:\Projects\SDGE_CNF_ESR\MapData\Plan\SWPPP\BMP_Detailed_Route_v3.mxd

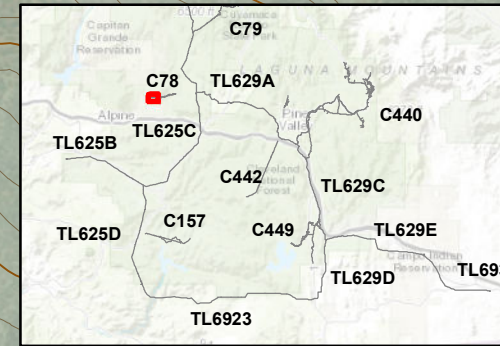
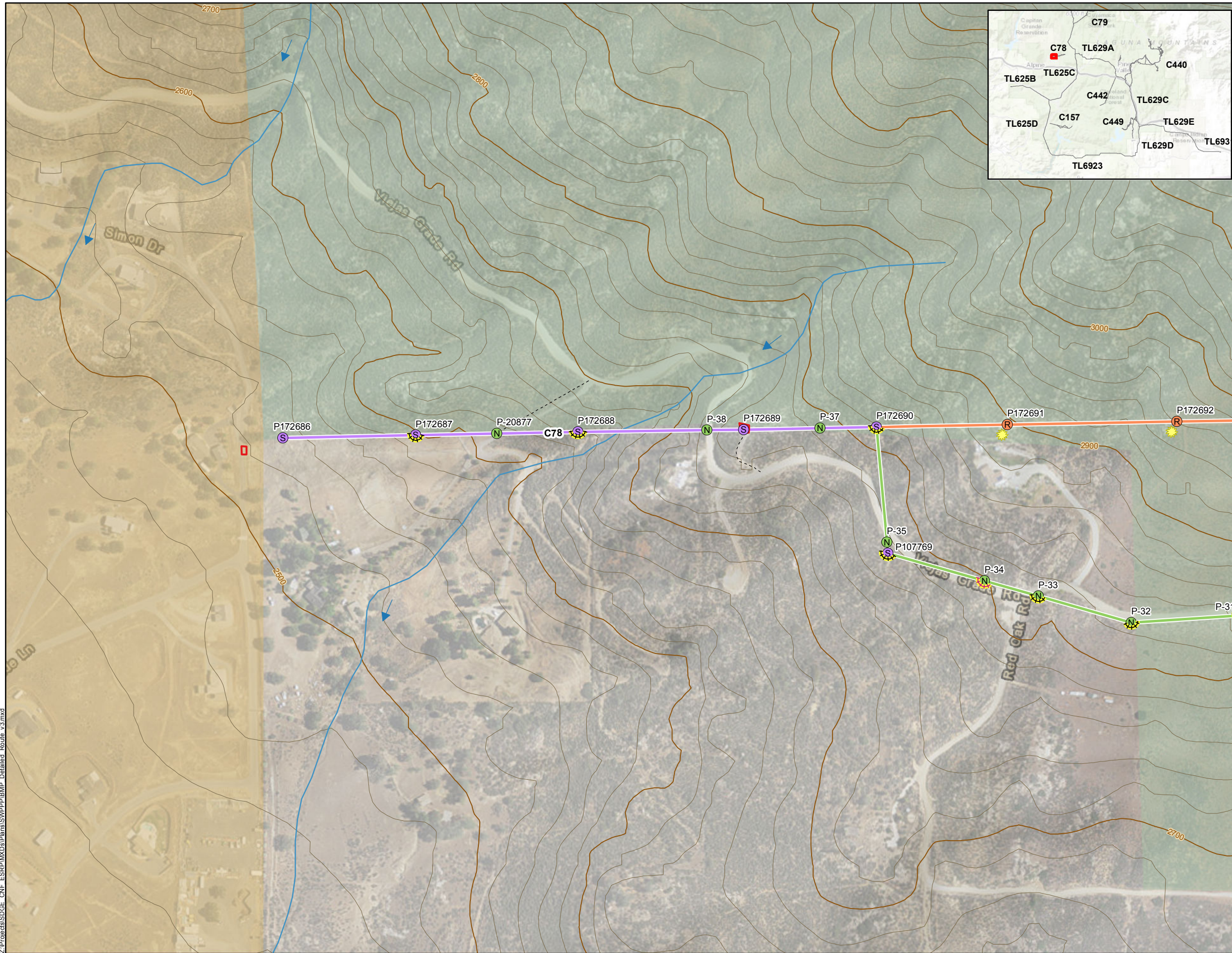

Site Map C78 Map 1 of 3

SDG&E MSUP and PTC Power Line Replacement Projects

LUP TYPE I PROJECT

- (N) New Steel Pole
- (S) Wood-to-Steel Replacement Pole
- (R) Removal Pole
- New Circuit (C)
- Circuit (C) Removal
- Circuit (C)
- Stringing Site
- - - - Access Road
- Stream
- ➔ Flow Direction
- 100-ft Contour Interval
- 20-ft Contour Interval
- United States Forest Service
- Bureau of Indian Affairs Land
- ☀ Preservation of Vegetation (BMP 4-01)
- ▬▬▬▬ Fiber Roll (BMP 1-03)
- ▬▬▬▬ Gravel Bag Berm (BMP 1-04)

- SWPPP Notes:
- Locations of SWPPP BMPs are not to scale.
 - SWPPP BMP locations are conceptual in nature and must be field-verified prior to construction.
 - Erosion and sediment controls shall be deployed prior to pavement or soil disturbance (where applicable) and as recommended by the QSP.
 - SDG&E BMP Details for sediment controls, erosion controls, waste management controls, and non-storm water discharge controls are contained within Appendix XI Construction BMPs of the Project SWPPP.
 - Preserve existing vegetation within all designated construction areas in accordance with BMP 4-01.
 - Track-out shall be removed at the end of every business day and as frequently as necessary to keep adjacent roads clean and free of sediment.
 - Dust control shall be implemented as necessary during construction in accordance with dust (wind erosion) control Bmp 4-08.
 - All trash containers are required to be covered at all times.
 - Additional SWPPP BMPs shall be implemented as dictated by site conditions and as recommended by the QSP to prevent erosion and pollutant transport.

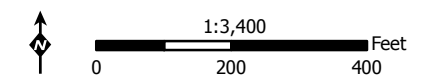

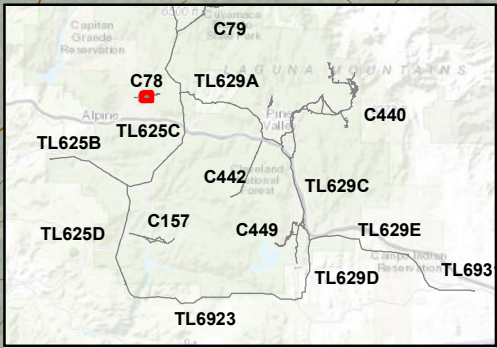
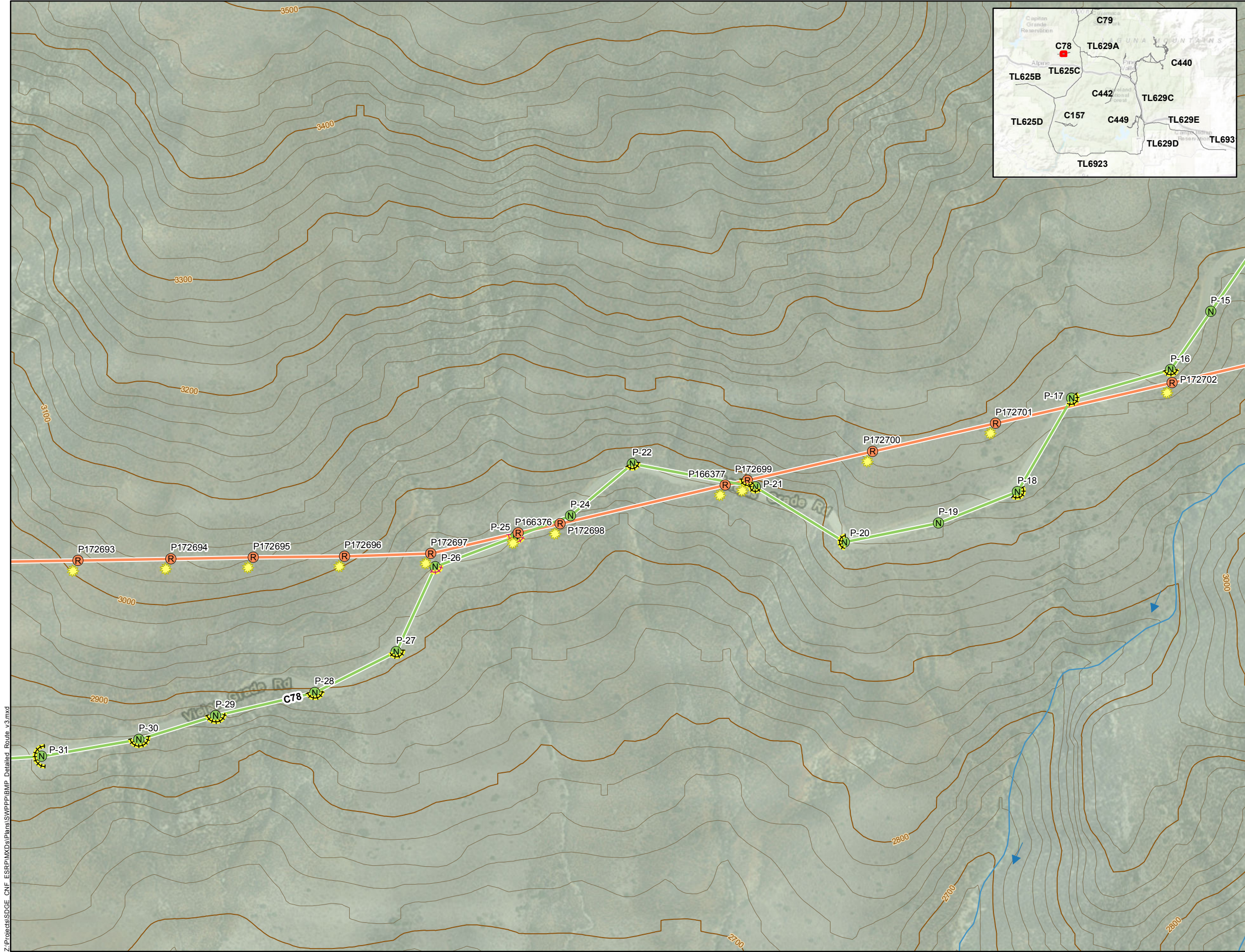









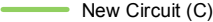
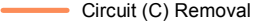

**Site Map
C78 Map 2 of 3**

**SDG&E MSUP and PTC
Power Line Replacement Projects**

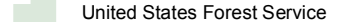
LUP TYPE I PROJECT

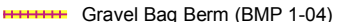
-  New Steel Pole
-  Removal Pole
-  New Circuit (C)
-  Circuit (C) Removal
-  Access Road
-  Stream
-  Flow Direction
-  100-ft Contour Interval
-  20-ft Contour Interval
-  United States Forest Service
-  Preservation of Vegetation (BMP 4-01)
-  Fiber Roll (BMP 1-03)
-  Gravel Bag Berm (BMP 1-04)

- SWPPP Notes:
1. Locations of SWPPP BMPs are not to scale.
 2. SWPPP BMP locations are conceptual in nature and must be field-verified prior to construction.
 3. Erosion and sediment controls shall be deployed prior to pavement or soil disturbance (where applicable) and as recommended by the QSP.
 4. SDG&E BMP Details for sediment controls, erosion controls, waste management controls, and non-storm water discharge controls are contained within Appendix XI Construction BMPs of the Project SWPPP.
 5. Preserve existing vegetation within all designated construction areas in accordance with BMP 4-01.
 6. Track-out shall be removed at the end of every business day and as frequently as necessary to keep adjacent roads clean and free of sediment.
 7. Dust control shall be implemented as necessary during construction in accordance with dust (wind erosion) control Bmp 4-08.
 8. All trash containers are required to be covered at all times.
 9. Additional SWPPP BMPs shall be implemented as dictated by site conditions and as recommended by the QSP to prevent erosion and pollutant transport.

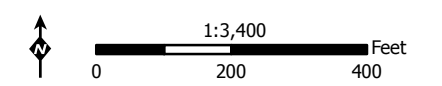



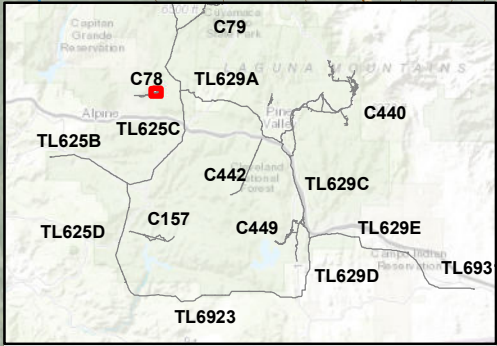
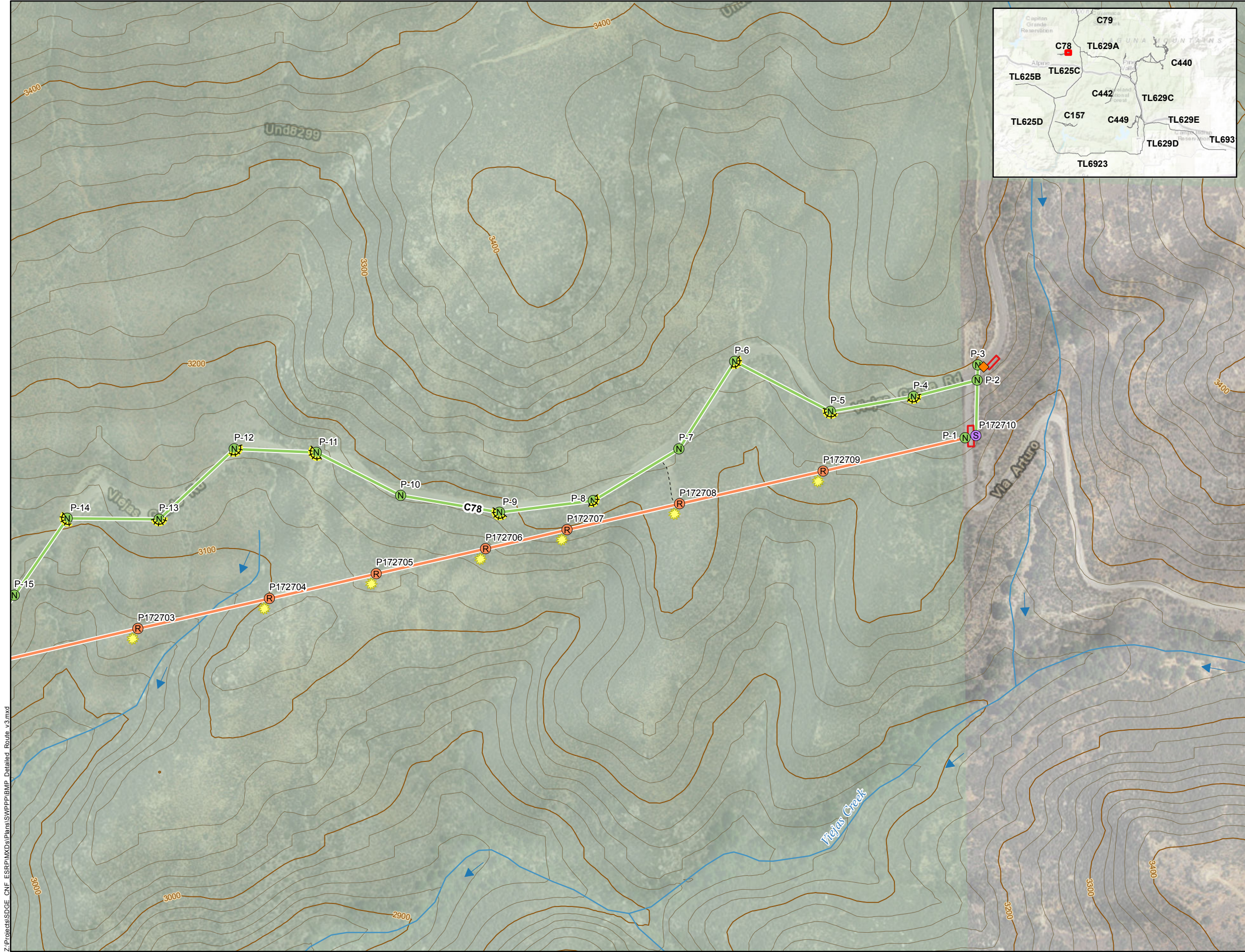











Z:\Projects\SDG&E CNF_ESR\MapData\BMP_SWPPP\BMP_Detailed_Route_v3.mxd



**Site Map
C78 Map 3 of 3**

**SDG&E MSUP and PTC
Power Line Replacement Projects**

LUP TYPE I PROJECT

-  New Steel Pole
-  Wood-to-Steel Replacement Pole
-  Removal Pole
-  New Circuit (C)
-  Circuit (C) Removal
-  Stringing Site
-  Access Road
-  Stream
-  Flow Direction
-  100-ft Contour Interval
-  20-ft Contour Interval
-  United States Forest Service
-  Material Delivery and Storage (BMP 2-01)
-  Preservation of Vegetation (BMP 4-01)
-  Fiber Roll (BMP 1-03)

- SWPPP Notes:
1. Locations of SWPPP BMPs are not to scale.
 2. SWPPP BMP locations are conceptual in nature and must be field-verified prior to construction.
 3. Erosion and sediment controls shall be deployed prior to pavement or soil disturbance (where applicable) and as recommended by the QSP.
 4. SDG&E BMP Details for sediment controls, erosion controls, waste management controls, and non-storm water discharge controls are contained within Appendix XI Construction BMPs of the Project SWPPP.
 5. Preserve existing vegetation within all designated construction areas in accordance with BMP 4-01.
 6. Track-out shall be removed at the end of every business day and as frequently as necessary to keep adjacent roads clean and free of sediment.
 7. Dust control shall be implemented as necessary during construction in accordance with dust (wind erosion) control Bmp 4-08.
 8. All trash containers are required to be covered at all times.
 9. Additional SWPPP BMPs shall be implemented as dictated by site conditions and as recommended by the QSP to prevent erosion and pollutant transport.

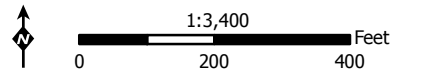

Z:\Projects\SDG&E CNF_ESR\PMX\DelPana\SWPPP\BMP_Detailed_Route_v3.mxd

ATTACHMENT D-2: TL682 SWPPP BMP SITE MAP

**Site Map
TL682
Map 1 of 49**

**Cleveland National Forest
Power Line Replacement Projects**

LUP TYPE I PROJECT

-  Fiber Roll (BMP 1-03)
-  Stream and Flow Direction
-  Contour, 20-ft Interval
-  Wood-to-Steel Replacement
-  Wood-to-Steel Replacement
-  Temp Pole Work Area
-  Footpath

-  Bureau of Indian Affairs Land
-  U.S. Forest Service

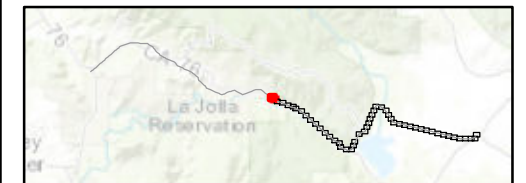

- SWPPP Notes:**
1. Locations of SWPPP BMPs are not to scale.
 2. SWPPP BMP locations are conceptual in nature and must be field-verified prior to construction.
 3. Erosion and sediment controls shall be deployed prior to pavement or soil disturbance (where applicable) and as recommended by the QSP.
 4. SDG&E BMP Details for sediment controls, erosion controls, waste management controls, and non-storm water discharge controls are contained within Appendix XI Construction BMPs of the Project SWPPP.
 5. Preserve existing vegetation within all designated construction areas in accordance with BMP 4-01.
 6. Track-out shall be removed at the end of every business day and as frequently as necessary to keep adjacent roads clean and free of sediment.
 7. Dust control shall be implemented as necessary during construction in accordance with dust (wind erosion) control Bmp 4-08.
 8. All trash containers are required to be covered at all times.
 9. Additional SWPPP BMPs shall be implemented as dictated by site conditions and as recommended by the QSP to prevent erosion and pollutant transport.
 10. Erosion and sediment control BMP implementation at sites accessed by helicopter will be determined in the field by the QSP.

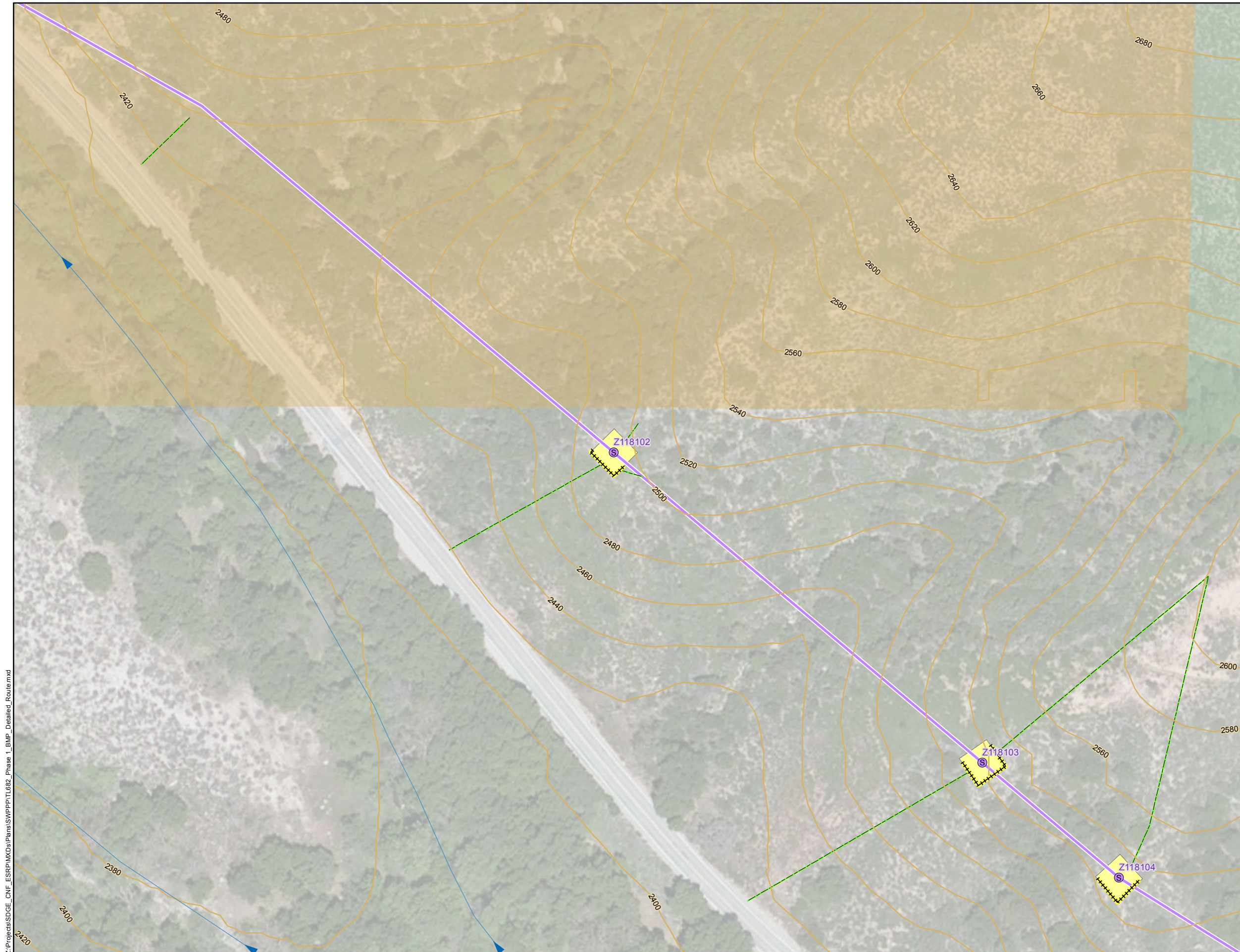
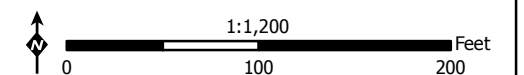













Z:\Projects\SDGE_CNF_ESRPI\MXData\Plans\SWPPP\TL682_Phase 1_BMP_Detailed_Route.mxd

**Site Map
TL682
Map 2 of 49**

**Cleveland National Forest
Power Line Replacement Projects**

LUP TYPE I PROJECT

-  Fiber Roll (BMP 1-03)
-  Check Dam
-  Tracking Controls (BMP-1-07)
-  Stream and Flow Direction
-  Contour, 20-ft Interval
-  Pending
-  Wood-to-Steel Replacement
-  Wood-to-Steel Replacement
-  Anchor Work Area
-  Temp Pole Work Area
-  RFS Anchor
-  Footpath
-  Navigation Access Road

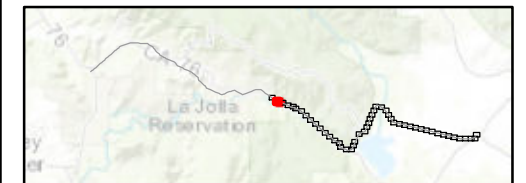

- SWPPP Notes:
1. Locations of SWPPP BMPs are not to scale.
 2. SWPPP BMP locations are conceptual in nature and must be field-verified prior to construction.
 3. Erosion and sediment controls shall be deployed prior to pavement or soil disturbance (where applicable) and as recommended by the QSP.
 4. SDG&E BMP Details for sediment controls, erosion controls, waste management controls, and non-storm water discharge controls are contained within Appendix XI Construction BMPs of the Project SWPPP.
 5. Preserve existing vegetation within all designated construction areas in accordance with BMP 4-01.
 6. Track-out shall be removed at the end of every business day and as frequently as necessary to keep adjacent roads clean and free of sediment.
 7. Dust control shall be implemented as necessary during construction in accordance with dust (wind erosion) control Bmp 4-08.
 8. All trash containers are required to be covered at all times.
 9. Additional SWPPP BMPs shall be implemented as dictated by site conditions and as recommended by the QSP to prevent erosion and pollutant transport.
 10. Erosion and sediment control BMP implementation at sites accessed by helicopter will be determined in the field by the QSP.

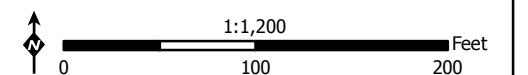











Z:\Projects\SDGE_CNF_ESRPI\MXDs\Plans\SWPPP\TL682_Phase 1_BMP_Detailed_Route.mxd

**Site Map
TL682
Map 3 of 49**

**Cleveland National Forest
Power Line Replacement Projects**

LUP TYPE I PROJECT

-  Fiber Roll (BMP 1-03)
-  Check Dam
-  Stream and Flow Direction
-  Contour, 20-ft Interval
-  Pending
-  Wood-to-Steel Replacement
-  Wood-to-Steel Replacement
-  Temp Pole Work Area
-  Construction Access Only
-  Footpath
-  Navigation Access Road

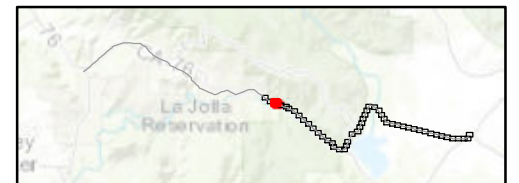

- SWPPP Notes:**
1. Locations of SWPPP BMPs are not to scale.
 2. SWPPP BMP locations are conceptual in nature and must be field-verified prior to construction.
 3. Erosion and sediment controls shall be deployed prior to pavement or soil disturbance (where applicable) and as recommended by the QSP.
 4. SDG&E BMP Details for sediment controls, erosion controls, waste management controls, and non-storm water discharge controls are contained within Appendix XI Construction BMPs of the Project SWPPP.
 5. Preserve existing vegetation within all designated construction areas in accordance with BMP 4-01.
 6. Track-out shall be removed at the end of every business day and as frequently as necessary to keep adjacent roads clean and free of sediment.
 7. Dust control shall be implemented as necessary during construction in accordance with dust (wind erosion) control Bmp 4-08.
 8. All trash containers are required to be covered at all times.
 9. Additional SWPPP BMPs shall be implemented as dictated by site conditions and as recommended by the QSP to prevent erosion and pollutant transport.
 10. Erosion and sediment control BMP implementation at sites accessed by helicopter will be determined in the field by the QSP.

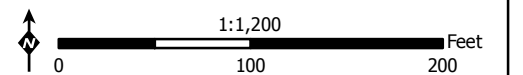









Z:\Projects\SDGE_CNF_ESR\IMX\Plans\SWPPP\TL682_Phase 1_BMP_Detailed_Route.mxd

**Site Map
TL682
Map 4 of 49**

**Cleveland National Forest
Power Line Replacement Projects**

LUP TYPE I PROJECT

-  Fiber Roll (BMP 1-03)
-  Stream and Flow Direction
-  Contour, 20-ft Interval
-  Wood-to-Steel Replacement
-  Wood-to-Steel Replacement
-  Temp Pole Work Area
-  Footpath
-  U.S. Forest Service

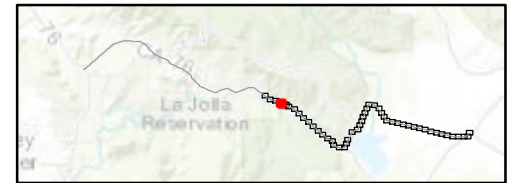
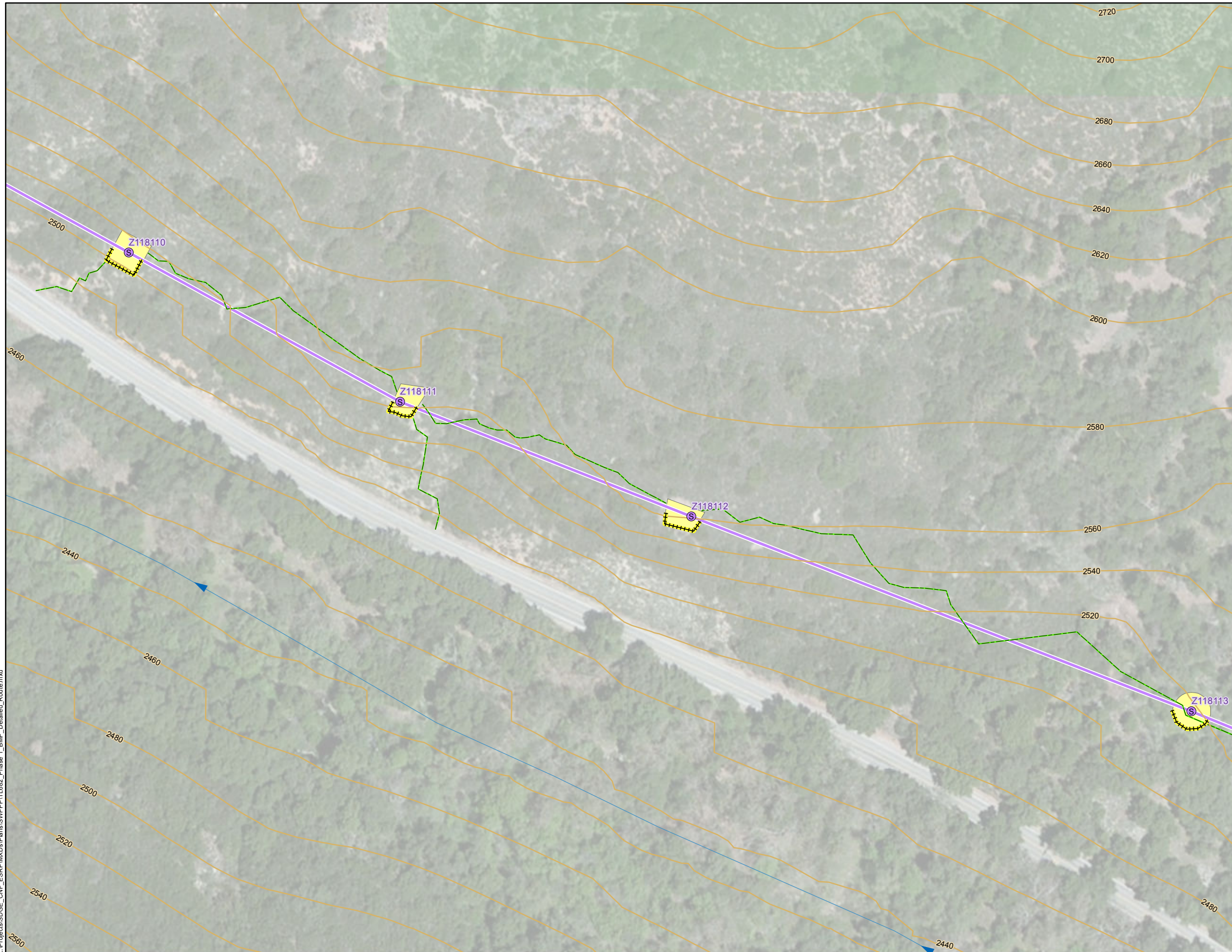

- SWPPP Notes:**
1. Locations of SWPPP BMPs are not to scale.
 2. SWPPP BMP locations are conceptual in nature and must be field-verified prior to construction.
 3. Erosion and sediment controls shall be deployed prior to pavement or soil disturbance (where applicable) and as recommended by the QSP.
 4. SDG&E BMP Details for sediment controls, erosion controls, waste management controls, and non-storm water discharge controls are contained within Appendix XI Construction BMPs of the Project SWPPP.
 5. Preserve existing vegetation within all designated construction areas in accordance with BMP 4-01.
 6. Track-out shall be removed at the end of every business day and as frequently as necessary to keep adjacent roads clean and free of sediment.
 7. Dust control shall be implemented as necessary during construction in accordance with dust (wind erosion) control Bmp 4-08.
 8. All trash containers are required to be covered at all times.
 9. Additional SWPPP BMPs shall be implemented as dictated by site conditions and as recommended by the QSP to prevent erosion and pollutant transport.
 10. Erosion and sediment control BMP implementation at sites accessed by helicopter will be determined in the field by the QSP.

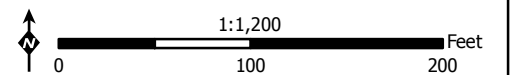

**Site Map
TL682
Map 5 of 49**

**Cleveland National Forest
Power Line Replacement Projects**

LUP TYPE I PROJECT

-  Fiber Roll (BMP 1-03)
-  Silt Fence (BMP 1-02)
-  Tracking Controls (BMP-1-07)
-  Stream and Flow Direction
-  Contour, 20-ft Interval
-  Pending
-  Wood-to-Steel Replacement
-  Wood-to-Steel Replacement 12kV Only
-  Wood-to-Steel Replacement
-  Anchor Work Area
-  Temp Pole Work Area
-  RFS Anchor
-  Construction Access Only
-  Footpath
-  Navigation Access Road

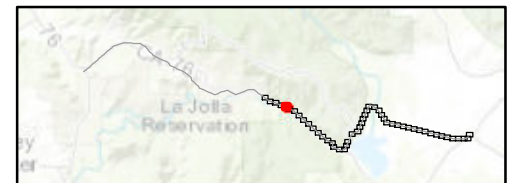

- SWPPP Notes:**
1. Locations of SWPPP BMPs are not to scale.
 2. SWPPP BMP locations are conceptual in nature and must be field-verified prior to construction.
 3. Erosion and sediment controls shall be deployed prior to pavement or soil disturbance (where applicable) and as recommended by the QSP.
 4. SDG&E BMP Details for sediment controls, erosion controls, waste management controls, and non-storm water discharge controls are contained within Appendix XI Construction BMPs of the Project SWPPP.
 5. Preserve existing vegetation within all designated construction areas in accordance with BMP 4-01.
 6. Track-out shall be removed at the end of every business day and as frequently as necessary to keep adjacent roads clean and free of sediment.
 7. Dust control shall be implemented as necessary during construction in accordance with dust (wind erosion) control Bmp 4-08.
 8. All trash containers are required to be covered at all times.
 9. Additional SWPPP BMPs shall be implemented as dictated by site conditions and as recommended by the QSP to prevent erosion and pollutant transport.
 10. Erosion and sediment control BMP implementation at sites accessed by helicopter will be determined in the field by the QSP.

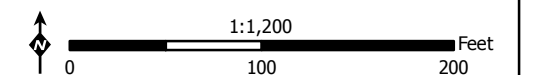















Z:\Projects\SDGE_CNF_ESR\IWX\Plans\SWPPP\TL682_Phase 1_BMP_Detailed_Route.mxd

**Site Map
TL682
Map 6 of 49**

**Cleveland National Forest
Power Line Replacement Projects**

LUP TYPE I PROJECT

-  Fiber Roll (BMP 1-03)
-  Stream and Flow Direction
-  Contour, 20-ft Interval
-  Pending
-  Wood-to-Steel Replacement
-  Wood-to-Steel Replacement 12kV Only
-  Wood-to-Steel Replacement
-  Anchor Work Area
-  Temp Pole Work Area
-  RFS Anchor
-  Construction Access Only
-  Footpath
-  Navigation Access Road
-  U.S. Forest Service

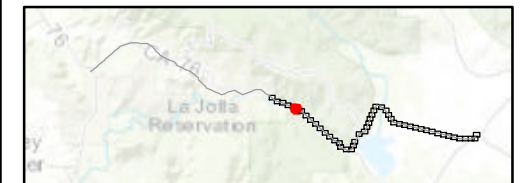

- SWPPP Notes:
1. Locations of SWPPP BMPs are not to scale.
 2. SWPPP BMP locations are conceptual in nature and must be field-verified prior to construction.
 3. Erosion and sediment controls shall be deployed prior to pavement or soil disturbance (where applicable) and as recommended by the QSP.
 4. SDG&E BMP Details for sediment controls, erosion controls, waste management controls, and non-storm water discharge controls are contained within Appendix XI Construction BMPs of the Project SWPPP.
 5. Preserve existing vegetation within all designated construction areas in accordance with BMP 4-01.
 6. Track-out shall be removed at the end of every business day and as frequently as necessary to keep adjacent roads clean and free of sediment.
 7. Dust control shall be implemented as necessary during construction in accordance with dust (wind erosion) control Bmp 4-08.
 8. All trash containers are required to be covered at all times.
 9. Additional SWPPP BMPs shall be implemented as dictated by site conditions and as recommended by the QSP to prevent erosion and pollutant transport.
 10. Erosion and sediment control BMP implementation at sites accessed by helicopter will be determined in the field by the QSP.

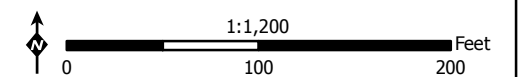











Z:\Projects\SDGE_CNF_ESRP\MXData\Plans\SWPPP\TL682_Phase 1_BMP_Detailed_Route.mxd

**Site Map
TL682
Map 7 of 49**

**Cleveland National Forest
Power Line Replacement Projects**

LUP TYPE I PROJECT

-  Fiber Roll (BMP 1-03)
-  Stream and Flow Direction
-  Contour, 20-ft Interval
-  Wood-to-Steel Replacement
-  Wood-to-Steel Replacement
-  Anchor Work Area
-  Temp Pole Work Area
-  RFS Anchor
-  Footpath
-  U.S. Forest Service

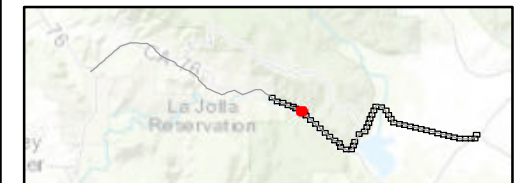

- SWPPP Notes:**
1. Locations of SWPPP BMPs are not to scale.
 2. SWPPP BMP locations are conceptual in nature and must be field-verified prior to construction.
 3. Erosion and sediment controls shall be deployed prior to pavement or soil disturbance (where applicable) and as recommended by the QSP.
 4. SDG&E BMP Details for sediment controls, erosion controls, waste management controls, and non-storm water discharge controls are contained within Appendix XI Construction BMPs of the Project SWPPP.
 5. Preserve existing vegetation within all designated construction areas in accordance with BMP 4-01.
 6. Track-out shall be removed at the end of every business day and as frequently as necessary to keep adjacent roads clean and free of sediment.
 7. Dust control shall be implemented as necessary during construction in accordance with dust (wind erosion) control Bmp 4-08.
 8. All trash containers are required to be covered at all times.
 9. Additional SWPPP BMPs shall be implemented as dictated by site conditions and as recommended by the QSP to prevent erosion and pollutant transport.
 10. Erosion and sediment control BMP implementation at sites accessed by helicopter will be determined in the field by the QSP.

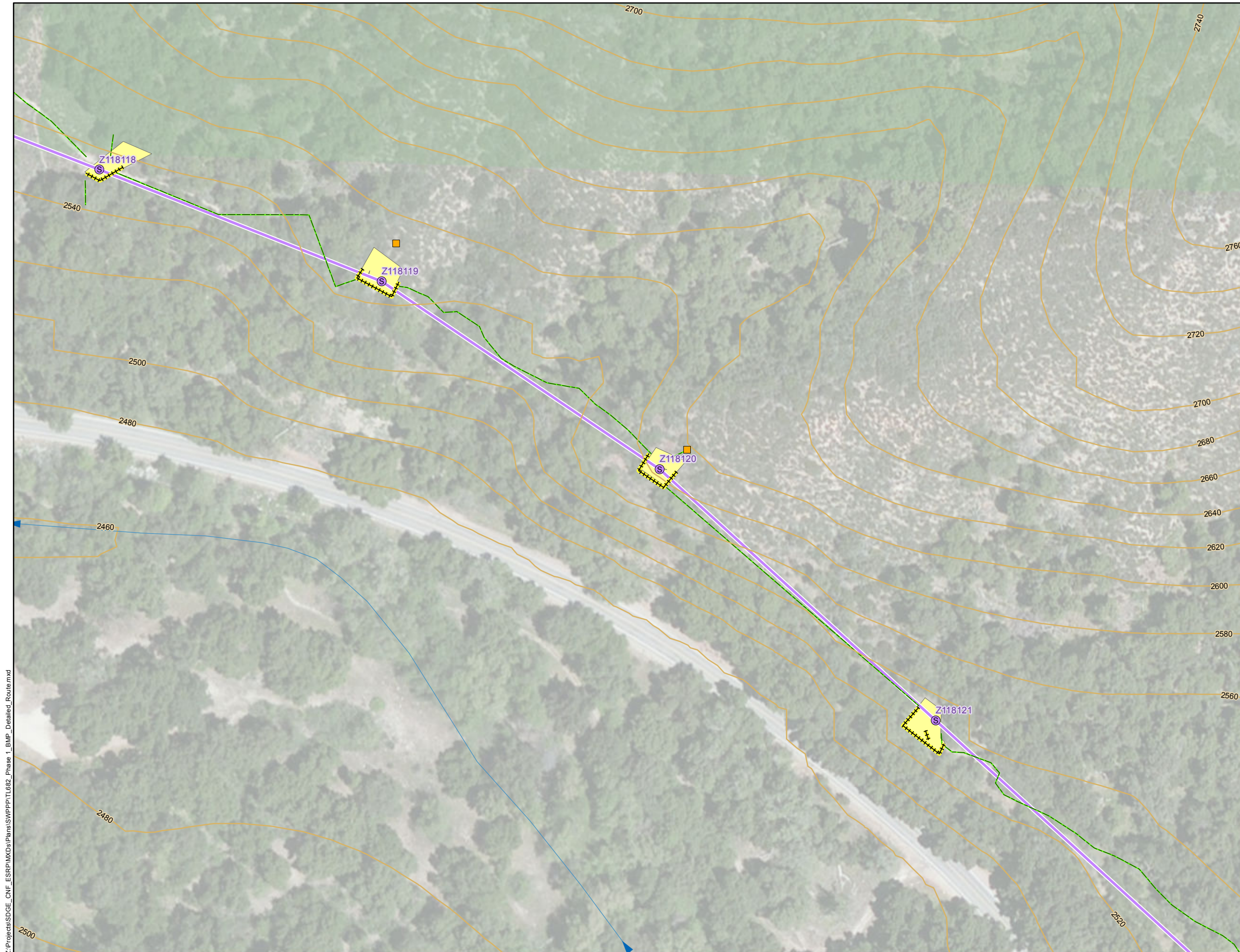
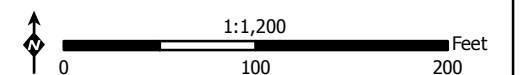











Z:\Projects\SDGE_CNF_ESRP\MXData\Plans\SWPPP\TL682_Phase 1_BMP_Detailed_Route.mxd

Site Map
TL682
Map 8 of 49

Cleveland National Forest
Power Line Replacement Projects

LUP TYPE I PROJECT

-  Fiber Roll (BMP 1-03)
-  Stream and Flow Direction
-  Contour, 20-ft Interval
-  Wood-to-Steel Replacement
-  Wood-to-Steel Replacement
-  Temp Pole Work Area
-  Construction Access Only
-  Footpath
-  Navigation Access Road
-  U.S. Forest Service

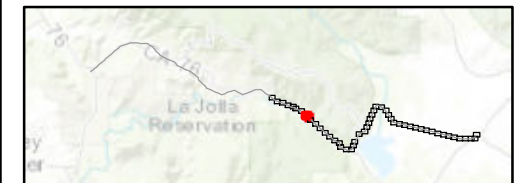

SWPPP Notes:

1. Locations of SWPPP BMPs are not to scale.
2. SWPPP BMP locations are conceptual in nature and must be field-verified prior to construction.
3. Erosion and sediment controls shall be deployed prior to pavement or soil disturbance (where applicable) and as recommended by the QSP.
4. SDG&E BMP Details for sediment controls, erosion controls, waste management controls, and non-storm water discharge controls are contained within Appendix XI Construction BMPs of the Project SWPPP.
5. Preserve existing vegetation within all designated construction areas in accordance with BMP 4-01.
6. Track-out shall be removed at the end of every business day and as frequently as necessary to keep adjacent roads clean and free of sediment.
7. Dust control shall be implemented as necessary during construction in accordance with dust (wind erosion) control Bmp 4-08.
8. All trash containers are required to be covered at all times.
9. Additional SWPPP BMPs shall be implemented as dictated by site conditions and as recommended by the QSP to prevent erosion and pollutant transport.
10. Erosion and sediment control BMP implementation at sites accessed by helicopter will be determined in the field by the QSP.

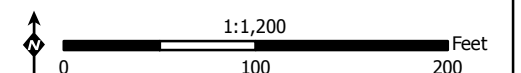









Z:\Projects\SDGE_CNF_ESR\MX\Plans\SWPPP\TL682_Phase I_BMP_Detailed_Route.mxd

Z:\Projects\SDGE_CNF_ESRP\MXDs\Plans\SWPPP\TL682_Phase 1_BMP_Detailed_Route.mxd

Site Map TL682 Map 9 of 49

Cleveland National Forest Power Line Replacement Projects

LUP TYPE I PROJECT

-  Fiber Roll (BMP 1-03)
-  Stream and Flow Direction
-  Contour, 20-ft Interval
-  Wood-to-Steel Replacement
-  Wood-to-Steel Replacement
-  Temp Pole Work Area
-  Footpath
-  U.S. Forest Service

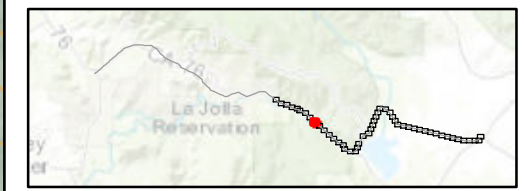



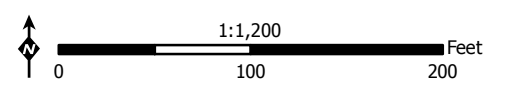







- SWPPP Notes:
1. Locations of SWPPP BMPs are not to scale.
 2. SWPPP BMP locations are conceptual in nature and must be field-verified prior to construction.
 3. Erosion and sediment controls shall be deployed prior to pavement or soil disturbance (where applicable) and as recommended by the QSP.
 4. SDG&E BMP Details for sediment controls, erosion controls, waste management controls, and non-storm water discharge controls are contained within Appendix XI Construction BMPs of the Project SWPPP.
 5. Preserve existing vegetation within all designated construction areas in accordance with BMP 4-01.
 6. Track-out shall be removed at the end of every business day and as frequently as necessary to keep adjacent roads clean and free of sediment.
 7. Dust control shall be implemented as necessary during construction in accordance with dust (wind erosion) control Bmp 4-08.
 8. All trash containers are required to be covered at all times.
 9. Additional SWPPP BMPs shall be implemented as dictated by site conditions and as recommended by the QSP to prevent erosion and pollutant transport.
 10. Erosion and sediment control BMP implementation at sites accessed by helicopter will be determined in the field by the QSP.



**Site Map
TL682
Map 10 of 49**

**Cleveland National Forest
Power Line Replacement Projects**

LUP TYPE I PROJECT

-  Fiber Roll (BMP 1-03)
-  Stream and Flow Direction
-  Contour, 20-ft Interval
-  Wood-to-Steel Replacement
-  Wood-to-Steel Replacement
-  Anchor Work Area
-  Temp Pole Work Area
-  RFS Anchor
-  Footpath
-  Navigation Access Road
-  U.S. Forest Service

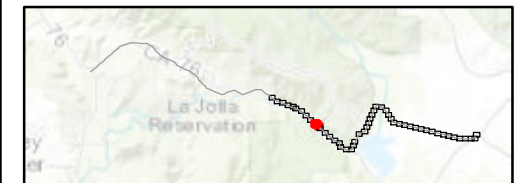

- SWPPP Notes:**
1. Locations of SWPPP BMPs are not to scale.
 2. SWPPP BMP locations are conceptual in nature and must be field-verified prior to construction.
 3. Erosion and sediment controls shall be deployed prior to pavement or soil disturbance (where applicable) and as recommended by the QSP.
 4. SDG&E BMP Details for sediment controls, erosion controls, waste management controls, and non-storm water discharge controls are contained within Appendix XI Construction BMPs of the Project SWPPP.
 5. Preserve existing vegetation within all designated construction areas in accordance with BMP 4-01.
 6. Track-out shall be removed at the end of every business day and as frequently as necessary to keep adjacent roads clean and free of sediment.
 7. Dust control shall be implemented as necessary during construction in accordance with dust (wind erosion) control Bmp 4-08.
 8. All trash containers are required to be covered at all times.
 9. Additional SWPPP BMPs shall be implemented as dictated by site conditions and as recommended by the QSP to prevent erosion and pollutant transport.
 10. Erosion and sediment control BMP implementation at sites accessed by helicopter will be determined in the field by the QSP.

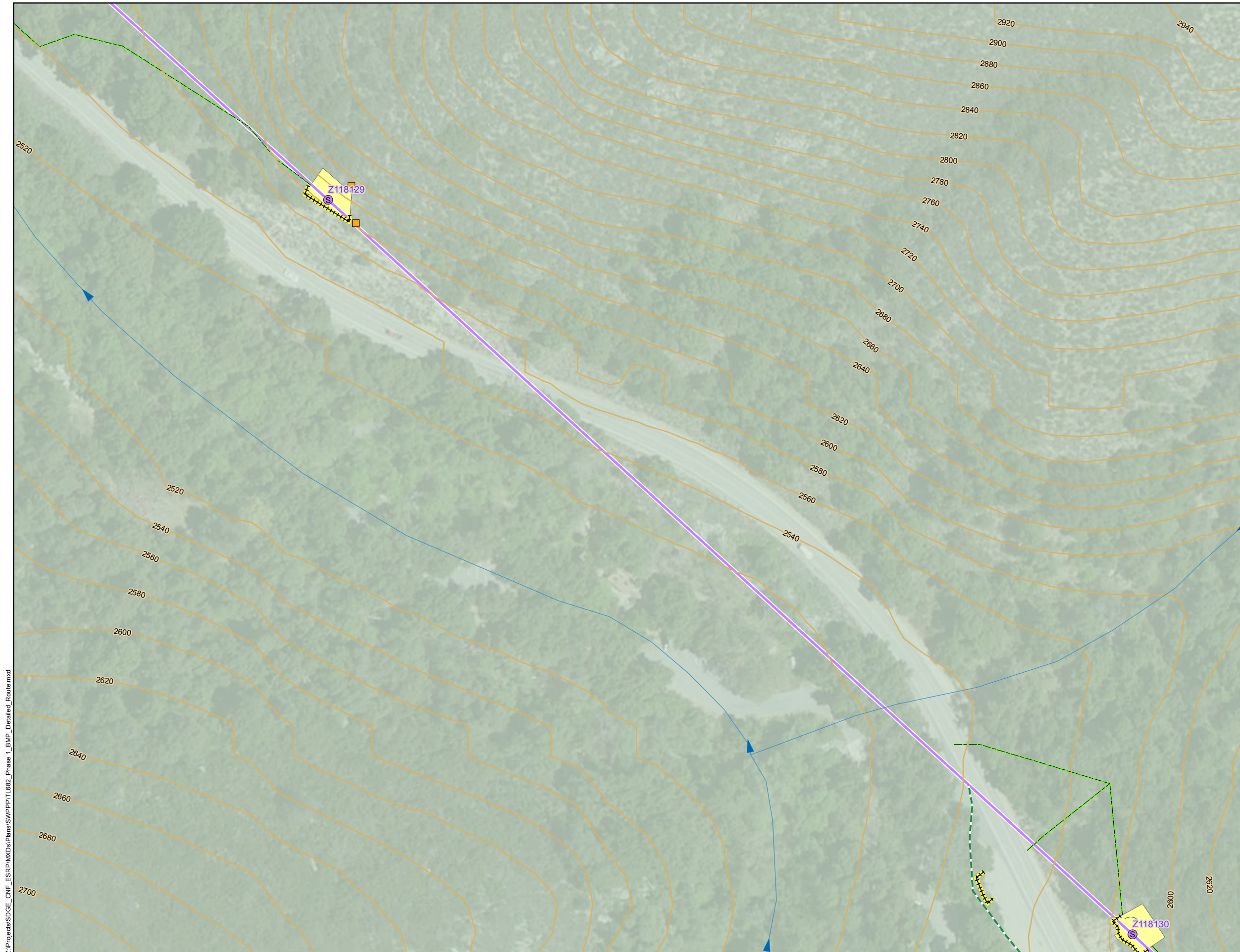
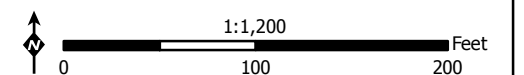













Z:\Projects\SDGE_CNF_ESR\IWX\Plans\SWPPP\TL682_Phase 1_BMP_Detailed_Route.mxd

**Site Map
TL682
Map 11 of 49**

**Cleveland National Forest
Power Line Replacement Projects**

LUP TYPE I PROJECT

-  Fiber Roll (BMP 1-03)
-  Stream and Flow Direction
-  Contour, 20-ft Interval
-  Pending
-  Wood-to-Steel Replacement
-  Wood-to-Steel Replacement
-  Anchor Work Area
-  Temp Pole Work Area
-  RFS Anchor
-  Footpath
-  Navigation Access Road
-  U.S. Forest Service

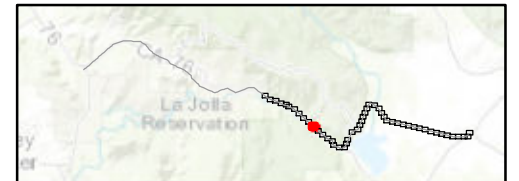

- SWPPP Notes:**
1. Locations of SWPPP BMPs are not to scale.
 2. SWPPP BMP locations are conceptual in nature and must be field-verified prior to construction.
 3. Erosion and sediment controls shall be deployed prior to pavement or soil disturbance (where applicable) and as recommended by the QSP.
 4. SDG&E BMP Details for sediment controls, erosion controls, waste management controls, and non-storm water discharge controls are contained within Appendix XI Construction BMPs of the Project SWPPP.
 5. Preserve existing vegetation within all designated construction areas in accordance with BMP 4-01.
 6. Track-out shall be removed at the end of every business day and as frequently as necessary to keep adjacent roads clean and free of sediment.
 7. Dust control shall be implemented as necessary during construction in accordance with dust (wind erosion) control Bmp 4-08.
 8. All trash containers are required to be covered at all times.
 9. Additional SWPPP BMPs shall be implemented as dictated by site conditions and as recommended by the QSP to prevent erosion and pollutant transport.
 10. Erosion and sediment control BMP implementation at sites accessed by helicopter will be determined in the field by the QSP.

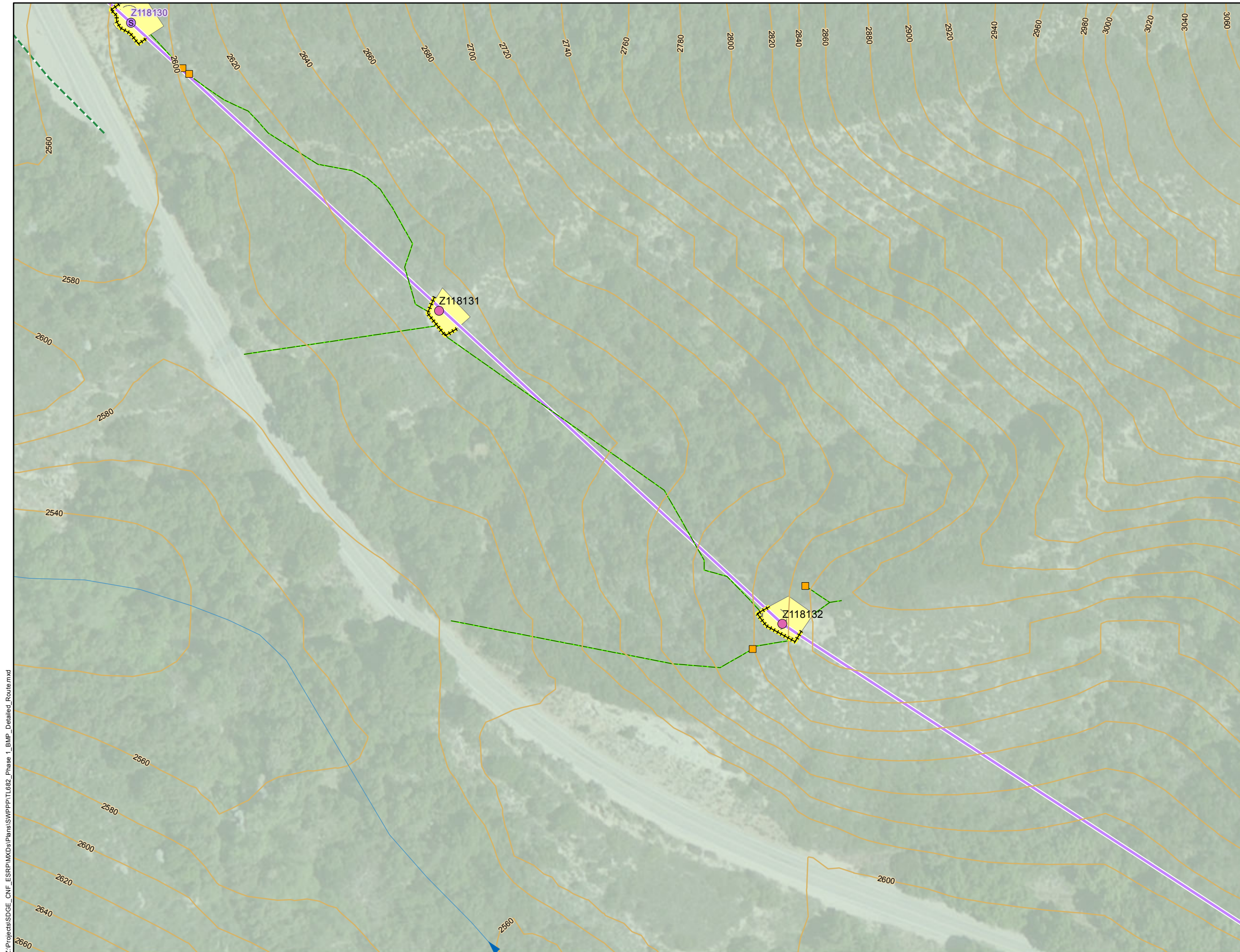
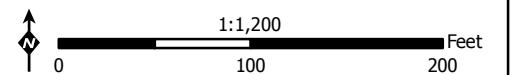











Z:\Projects\SDGE_CNF_ESR\IMX\Plans\SWPPP\TL682_Phase 1_BMP_Detailed_Route.mxd

**Site Map
TL682
Map 12 of 49**

**Cleveland National Forest
Power Line Replacement Projects**

LUP TYPE I PROJECT

-  Fiber Roll (BMP 1-03)
-  Stream and Flow Direction
-  Contour, 20-ft Interval
-  Wood-to-Steel Replacement
-  Wood-to-Steel Replacement
-  Anchor Work Area
-  Temp Pole Work Area
-  RFS Anchor
-  Footpath
-  U.S. Forest Service

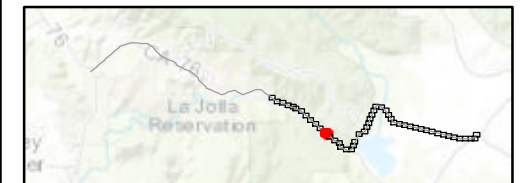

SWPPP Notes:

1. Locations of SWPPP BMPs are not to scale.
2. SWPPP BMP locations are conceptual in nature and must be field-verified prior to construction.
3. Erosion and sediment controls shall be deployed prior to pavement or soil disturbance (where applicable) and as recommended by the QSP.
4. SDG&E BMP Details for sediment controls, erosion controls, waste management controls, and non-storm water discharge controls are contained within Appendix XI Construction BMPs of the Project SWPPP.
5. Preserve existing vegetation within all designated construction areas in accordance with BMP 4-01.
6. Track-out shall be removed at the end of every business day and as frequently as necessary to keep adjacent roads clean and free of sediment.
7. Dust control shall be implemented as necessary during construction in accordance with dust (wind erosion) control Bmp 4-08.
8. All trash containers are required to be covered at all times.
9. Additional SWPPP BMPs shall be implemented as dictated by site conditions and as recommended by the QSP to prevent erosion and pollutant transport.
10. Erosion and sediment control BMP implementation at sites accessed by helicopter will be determined in the field by the QSP.

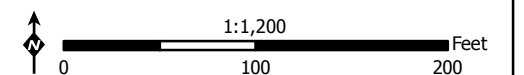











Z:\Projects\SDGE_CNF_ESR\MXData\Plans\SWPPP\TL682_Phase 1_BMP_Detailed_Route.mxd

**Site Map
TL682
Map 13 of 49**

**Cleveland National Forest
Power Line Replacement Projects**

LUP TYPE I PROJECT

-  Fiber Roll (BMP 1-03)
-  Stream and Flow Direction
-  Contour, 20-ft Interval
-  Wood-to-Steel Replacement
-  Wood-to-Steel Replacement
-  Anchor Work Area
-  Temp Pole Work Area
-  RFS Anchor
-  Footpath
-  U.S. Forest Service

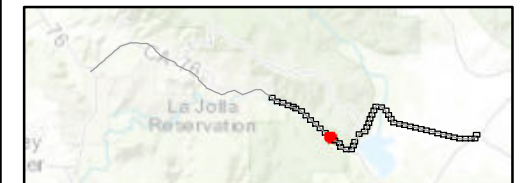

SWPPP Notes:

1. Locations of SWPPP BMPs are not to scale.
2. SWPPP BMP locations are conceptual in nature and must be field-verified prior to construction.
3. Erosion and sediment controls shall be deployed prior to pavement or soil disturbance (where applicable) and as recommended by the QSP.
4. SDG&E BMP Details for sediment controls, erosion controls, waste management controls, and non-storm water discharge controls are contained within Appendix XI Construction BMPs of the Project SWPPP.
5. Preserve existing vegetation within all designated construction areas in accordance with BMP 4-01.
6. Track-out shall be removed at the end of every business day and as frequently as necessary to keep adjacent roads clean and free of sediment.
7. Dust control shall be implemented as necessary during construction in accordance with dust (wind erosion) control Bmp 4-08.
8. All trash containers are required to be covered at all times.
9. Additional SWPPP BMPs shall be implemented as dictated by site conditions and as recommended by the QSP to prevent erosion and pollutant transport.
10. Erosion and sediment control BMP implementation at sites accessed by helicopter will be determined in the field by the QSP.

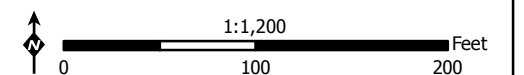











Z:\Projects\SDGE_CNF_ESR\MXData\Plans\SWPPP\TL682_Phase 1_BMP_Detailed_Route.mxd

**Site Map
TL682
Map 14 of 49**

**Cleveland National Forest
Power Line Replacement Projects**

LUP TYPE I PROJECT

-  Fiber Roll (BMP 1-03)
-  Stream and Flow Direction
-  Contour, 20-ft Interval
-  Wood-to-Steel Replacement
-  Wood-to-Steel Replacement
-  Anchor Work Area
-  Temp Pole Work Area
-  RFS Anchor
-  Footpath
-  Navigation Access Road
-  U.S. Forest Service

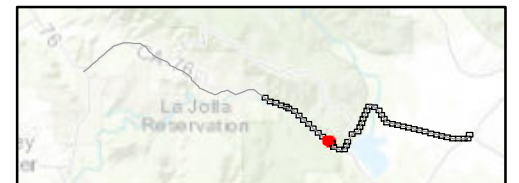

- SWPPP Notes:**
1. Locations of SWPPP BMPs are not to scale.
 2. SWPPP BMP locations are conceptual in nature and must be field-verified prior to construction.
 3. Erosion and sediment controls shall be deployed prior to pavement or soil disturbance (where applicable) and as recommended by the QSP.
 4. SDG&E BMP Details for sediment controls, erosion controls, waste management controls, and non-storm water discharge controls are contained within Appendix XI Construction BMPs of the Project SWPPP.
 5. Preserve existing vegetation within all designated construction areas in accordance with BMP 4-01.
 6. Track-out shall be removed at the end of every business day and as frequently as necessary to keep adjacent roads clean and free of sediment.
 7. Dust control shall be implemented as necessary during construction in accordance with dust (wind erosion) control Bmp 4-08.
 8. All trash containers are required to be covered at all times.
 9. Additional SWPPP BMPs shall be implemented as dictated by site conditions and as recommended by the QSP to prevent erosion and pollutant transport.
 10. Erosion and sediment control BMP implementation at sites accessed by helicopter will be determined in the field by the QSP.

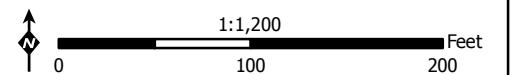











Z:\Projects\SDGE_CNF_ESRPI\MXData\Plans\SWPPP\TL682_Phase I_BMP_Detailed_Route.mxd

**Site Map
TL682
Map 15 of 49**

**Cleveland National Forest
Power Line Replacement Projects**

LUP TYPE I PROJECT

-  Fiber Roll (BMP 1-03)
-  Stream and Flow Direction
-  Contour, 20-ft Interval
-  Removal
-  Wood-to-Steel Replacement
-  Wood-to-Steel Replacement
-  Anchor Work Area
-  Temp Pole Work Area
-  RFS Anchor
-  Footpath
-  Navigation Access Road

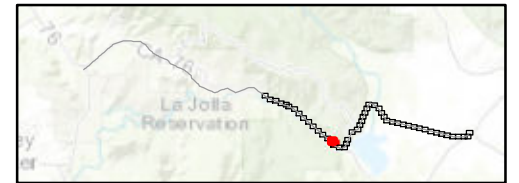

- SWPPP Notes:**
1. Locations of SWPPP BMPs are not to scale.
 2. SWPPP BMP locations are conceptual in nature and must be field-verified prior to construction.
 3. Erosion and sediment controls shall be deployed prior to pavement or soil disturbance (where applicable) and as recommended by the QSP.
 4. SDG&E BMP Details for sediment controls, erosion controls, waste management controls, and non-storm water discharge controls are contained within Appendix XI Construction BMPs of the Project SWPPP.
 5. Preserve existing vegetation within all designated construction areas in accordance with BMP 4-01.
 6. Track-out shall be removed at the end of every business day and as frequently as necessary to keep adjacent roads clean and free of sediment.
 7. Dust control shall be implemented as necessary during construction in accordance with dust (wind erosion) control Bmp 4-08.
 8. All trash containers are required to be covered at all times.
 9. Additional SWPPP BMPs shall be implemented as dictated by site conditions and as recommended by the QSP to prevent erosion and pollutant transport.
 10. Erosion and sediment control BMP implementation at sites accessed by helicopter will be determined in the field by the QSP.

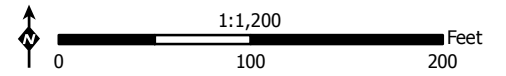











Z:\Projects\SDGE_CNF_ESR\IWX\Plans\SWPPP\TL682_Phase 1_BMP_Detailed_Route.mxd

**Site Map
TL682
Map 16 of 49**

**Cleveland National Forest
Power Line Replacement Projects**

LUP TYPE I PROJECT

-  Fiber Roll (BMP 1-03)
-  Stream and Flow Direction
-  Contour, 20-ft Interval
-  Removal
-  Wood-to-Steel Replacement
-  Wood-to-Steel Replacement
-  Anchor Work Area
-  Temp Pole Work Area
-  RFS Anchor
-  Footpath
-  U.S. Forest Service

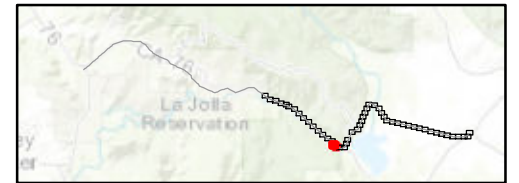



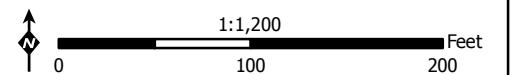





- SWPPP Notes:**
1. Locations of SWPPP BMPs are not to scale.
 2. SWPPP BMP locations are conceptual in nature and must be field-verified prior to construction.
 3. Erosion and sediment controls shall be deployed prior to pavement or soil disturbance (where applicable) and as recommended by the QSP.
 4. SDG&E BMP Details for sediment controls, erosion controls, waste management controls, and non-storm water discharge controls are contained within Appendix XI Construction BMPs of the Project SWPPP.
 5. Preserve existing vegetation within all designated construction areas in accordance with BMP 4-01.
 6. Track-out shall be removed at the end of every business day and as frequently as necessary to keep adjacent roads clean and free of sediment.
 7. Dust control shall be implemented as necessary during construction in accordance with dust (wind erosion) control Bmp 4-08.
 8. All trash containers are required to be covered at all times.
 9. Additional SWPPP BMPs shall be implemented as dictated by site conditions and as recommended by the QSP to prevent erosion and pollutant transport.
 10. Erosion and sediment control BMP implementation at sites accessed by helicopter will be determined in the field by the QSP.



**Site Map
TL682
Map 17 of 49**

**Cleveland National Forest
Power Line Replacement Projects**

LUP TYPE I PROJECT

-  Fiber Roll (BMP 1-03)
-  Stream and Flow Direction
-  Contour, 20-ft Interval
-  Wood-to-Steel Replacement
-  Wood-to-Steel Replacement
-  Anchor Work Area
-  Temp Pole Work Area
-  RFS Anchor
-  Footpath

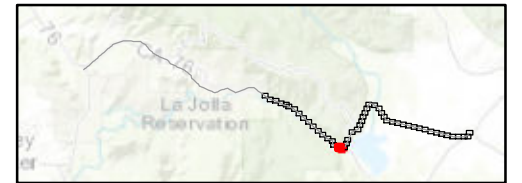



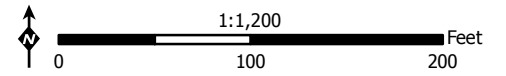









- SWPPP Notes:**
1. Locations of SWPPP BMPs are not to scale.
 2. SWPPP BMP locations are conceptual in nature and must be field-verified prior to construction.
 3. Erosion and sediment controls shall be deployed prior to pavement or soil disturbance (where applicable) and as recommended by the QSP.
 4. SDG&E BMP Details for sediment controls, erosion controls, waste management controls, and non-storm water discharge controls are contained within Appendix XI Construction BMPs of the Project SWPPP.
 5. Preserve existing vegetation within all designated construction areas in accordance with BMP 4-01.
 6. Track-out shall be removed at the end of every business day and as frequently as necessary to keep adjacent roads clean and free of sediment.
 7. Dust control shall be implemented as necessary during construction in accordance with dust (wind erosion) control Bmp 4-08.
 8. All trash containers are required to be covered at all times.
 9. Additional SWPPP BMPs shall be implemented as dictated by site conditions and as recommended by the QSP to prevent erosion and pollutant transport.
 10. Erosion and sediment control BMP implementation at sites accessed by helicopter will be determined in the field by the QSP.



**Site Map
TL682
Map 18 of 49**

**Cleveland National Forest
Power Line Replacement Projects**

LUP TYPE I PROJECT

-  Fiber Roll (BMP 1-03)
-  Stream and Flow Direction
-  Contour, 20-ft Interval
-  Wood-to-Steel Replacement
-  Wood-to-Steel Replacement
-  Anchor Work Area
-  Temp Access/Entry/Turnaround
-  Temp Pole Work Area
-  RFS Anchor
-  Construction Access Only
-  Footpath
-  Navigation Access Road

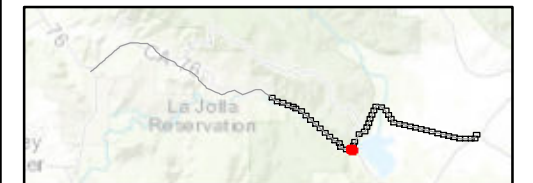

- SWPPP Notes:
1. Locations of SWPPP BMPs are not to scale.
 2. SWPPP BMP locations are conceptual in nature and must be field-verified prior to construction.
 3. Erosion and sediment controls shall be deployed prior to pavement or soil disturbance (where applicable) and as recommended by the QSP.
 4. SDG&E BMP Details for sediment controls, erosion controls, waste management controls, and non-storm water discharge controls are contained within Appendix XI Construction BMPs of the Project SWPPP.
 5. Preserve existing vegetation within all designated construction areas in accordance with BMP 4-01.
 6. Track-out shall be removed at the end of every business day and as frequently as necessary to keep adjacent roads clean and free of sediment.
 7. Dust control shall be implemented as necessary during construction in accordance with dust (wind erosion) control Bmp 4-08.
 8. All trash containers are required to be covered at all times.
 9. Additional SWPPP BMPs shall be implemented as dictated by site conditions and as recommended by the QSP to prevent erosion and pollutant transport.
 10. Erosion and sediment control BMP implementation at sites accessed by helicopter will be determined in the field by the QSP.

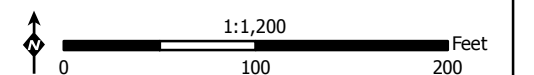











Z:\Projects\SDGE_CNF_ESRPI\WXData\Plans\SWPPP\TL682_Phase 1_BMP_Detailed_Route.mxd

**Site Map
TL682
Map 19 of 49**

**Cleveland National Forest
Power Line Replacement Projects**

LUP TYPE I PROJECT

-  Fiber Roll (BMP 1-03)
-  Stream and Flow Direction
-  Contour, 20-ft Interval
-  Wood-to-Steel Replacement
-  Wood-to-Steel Replacement
-  Anchor Work Area
-  Temp Pole Work Area
-  RFS Anchor
-  Footpath
-  U.S. Forest Service

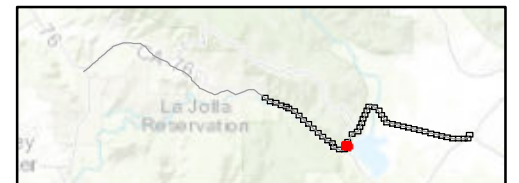

- SWPPP Notes:**
1. Locations of SWPPP BMPs are not to scale.
 2. SWPPP BMP locations are conceptual in nature and must be field-verified prior to construction.
 3. Erosion and sediment controls shall be deployed prior to pavement or soil disturbance (where applicable) and as recommended by the QSP.
 4. SDG&E BMP Details for sediment controls, erosion controls, waste management controls, and non-storm water discharge controls are contained within Appendix XI Construction BMPs of the Project SWPPP.
 5. Preserve existing vegetation within all designated construction areas in accordance with BMP 4-01.
 6. Track-out shall be removed at the end of every business day and as frequently as necessary to keep adjacent roads clean and free of sediment.
 7. Dust control shall be implemented as necessary during construction in accordance with dust (wind erosion) control Bmp 4-08.
 8. All trash containers are required to be covered at all times.
 9. Additional SWPPP BMPs shall be implemented as dictated by site conditions and as recommended by the QSP to prevent erosion and pollutant transport.
 10. Erosion and sediment control BMP implementation at sites accessed by helicopter will be determined in the field by the QSP.

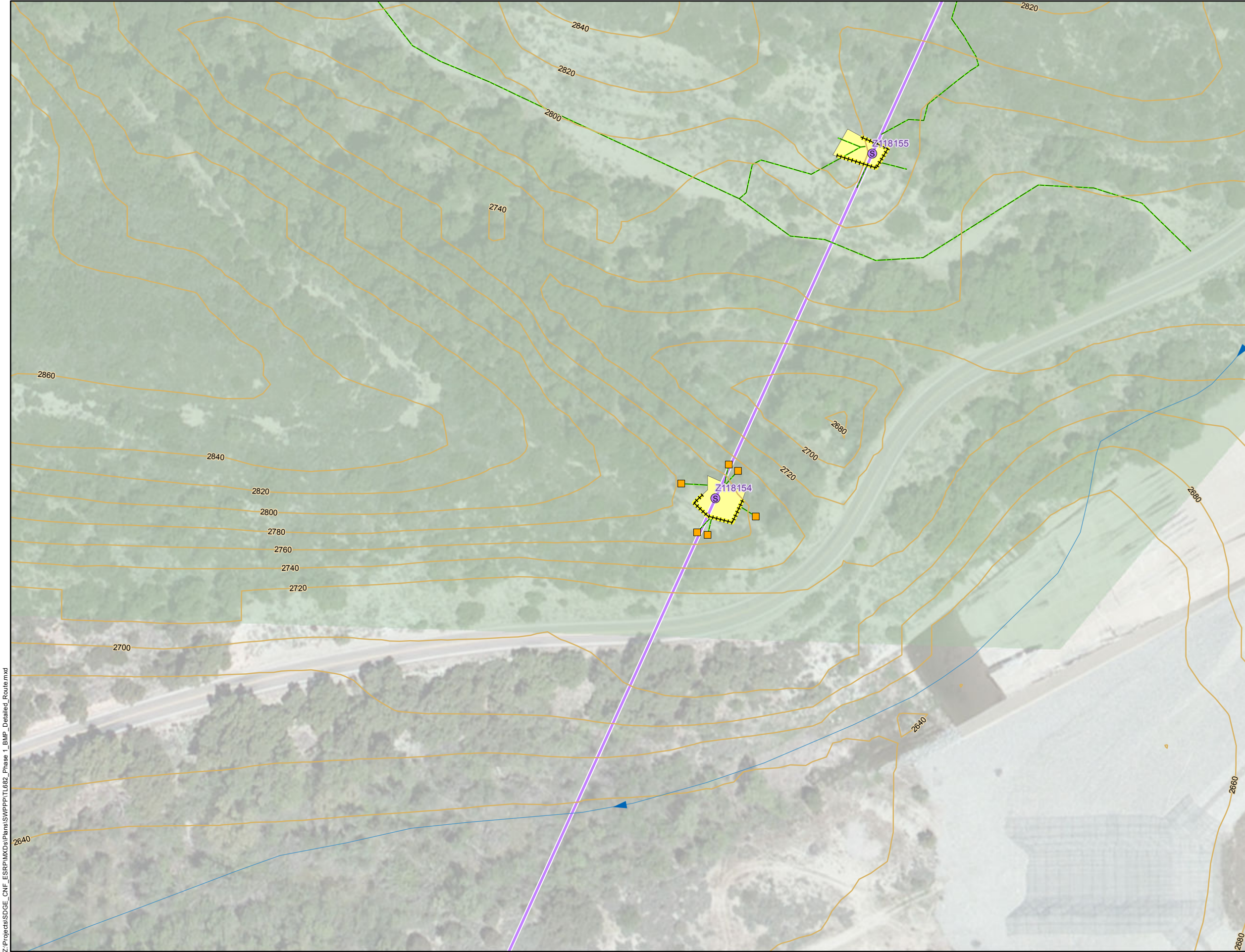
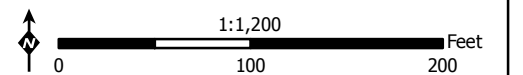











Z:\Projects\SDGE_CNF_ESR\IWX\Plans\SWPPP\TL682_Phase 1_BMP_Detailed_Route.mxd

**Site Map
TL682
Map 20 of 49**

**Cleveland National Forest
Power Line Replacement Projects**

LUP TYPE I PROJECT

-  Fiber Roll (BMP 1-03)
-  Contour, 20-ft Interval
-  Pole Top Work Only
-  Wood-to-Steel Replacement
-  Wood-to-Steel Replacement
-  Anchor Work Area
-  Temp Pole Work Area
-  RFS Anchor
-  Footpath
-  U.S. Forest Service

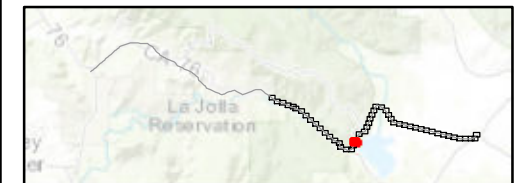

- SWPPP Notes:**
1. Locations of SWPPP BMPs are not to scale.
 2. SWPPP BMP locations are conceptual in nature and must be field-verified prior to construction.
 3. Erosion and sediment controls shall be deployed prior to pavement or soil disturbance (where applicable) and as recommended by the QSP.
 4. SDG&E BMP Details for sediment controls, erosion controls, waste management controls, and non-storm water discharge controls are contained within Appendix XI Construction BMPs of the Project SWPPP.
 5. Preserve existing vegetation within all designated construction areas in accordance with BMP 4-01.
 6. Track-out shall be removed at the end of every business day and as frequently as necessary to keep adjacent roads clean and free of sediment.
 7. Dust control shall be implemented as necessary during construction in accordance with dust (wind erosion) control Bmp 4-08.
 8. All trash containers are required to be covered at all times.
 9. Additional SWPPP BMPs shall be implemented as dictated by site conditions and as recommended by the QSP to prevent erosion and pollutant transport.
 10. Erosion and sediment control BMP implementation at sites accessed by helicopter will be determined in the field by the QSP.

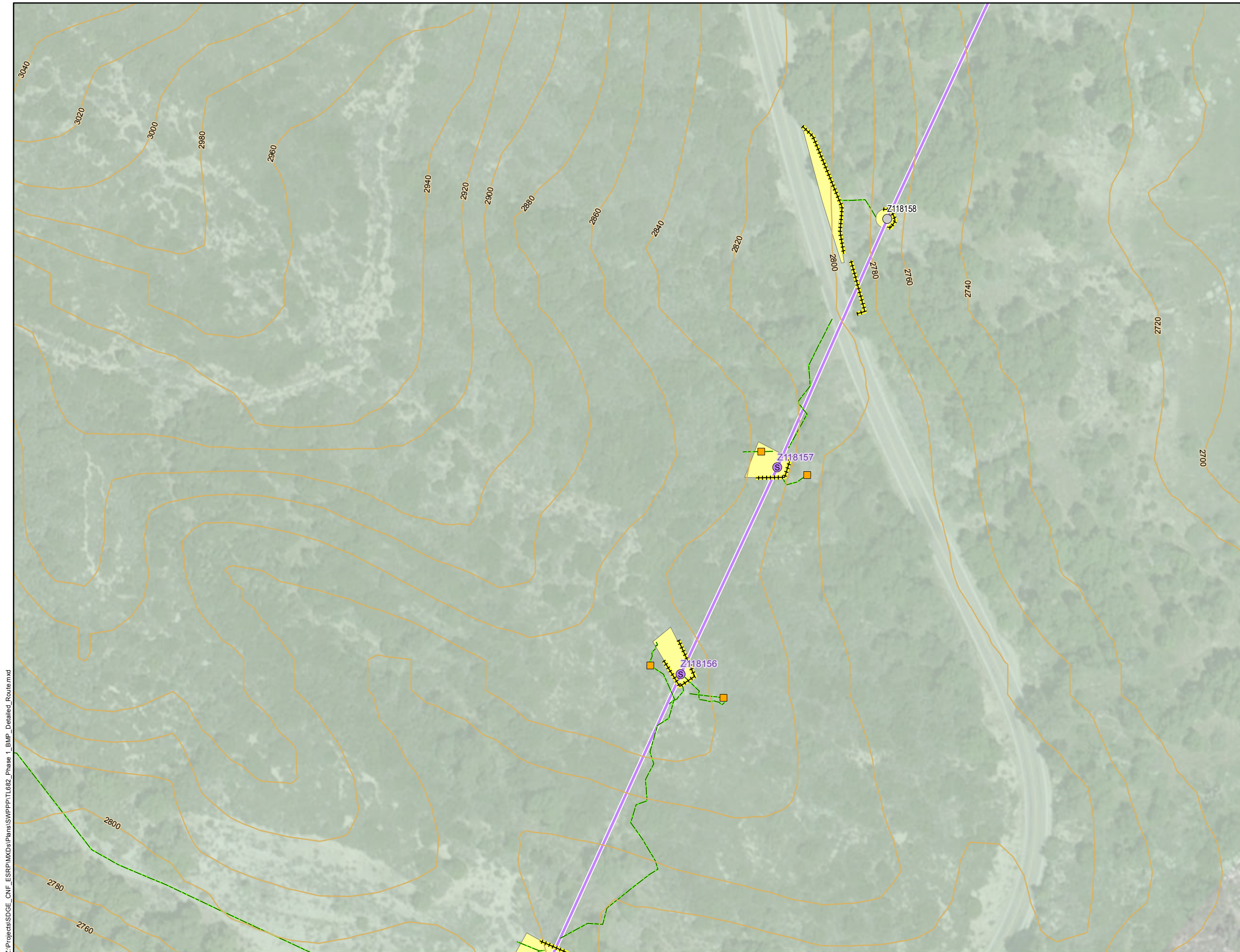
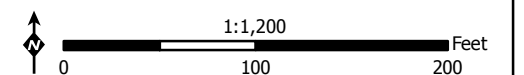

Z:\Projects\SDGE_CNF_ESR\IMX\Plans\SWPPP\TL682_Phase 1_BMP_Detailed_Route.mxd

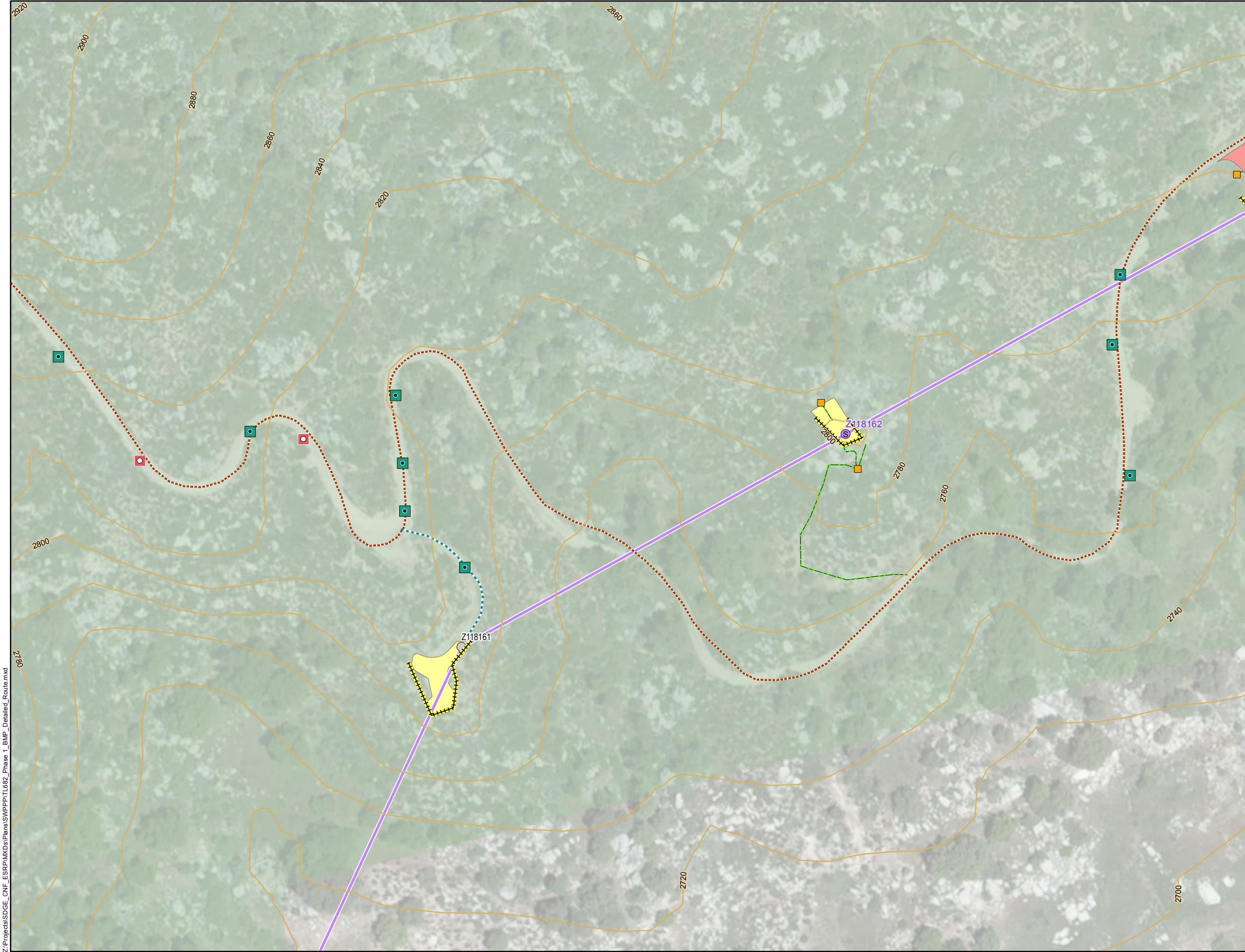















Z:\Projects\SDGE_CNF_ESRP\MXData\Plans\SWPPP\TL682_Phase 1_BMP_Detailed_Route.mxd

**Site Map
TL682
Map 21 of 49**

**Cleveland National Forest
Power Line Replacement Projects**

LUP TYPE I PROJECT

-  Fiber Roll (BMP 1-03)
-  Existing Velocity Dissipater
-  Existing Water Bar with Velocity Dissipater
-  Contour, 20-ft Interval
-  Pole Top Work Only
-  Wood-to-Steel Replacement
-  Wood-to-Steel Replacement
-  Anchor Work Area
-  Temp Access/Entry/Turnaround
-  Temp Pole Work Area
-  RFS Anchor
-  Construction Access Only
-  Footpath
-  Maintained Access Road
-  U.S. Forest Service

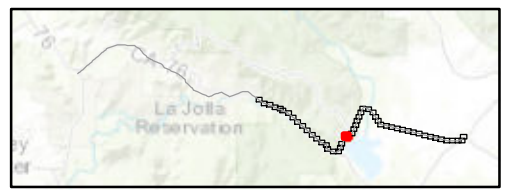



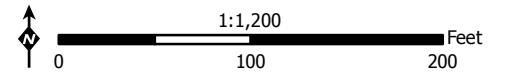









- SWPPP Notes:**
1. Locations of SWPPP BMPs are not to scale.
 2. SWPPP BMP locations are conceptual in nature and must be field-verified prior to construction.
 3. Erosion and sediment controls shall be deployed prior to pavement or soil disturbance (where applicable) and as recommended by the QSP.
 4. SDG&E BMP Details for sediment controls, erosion controls, waste management controls, and non-storm water discharge controls are contained within Appendix XI Construction BMPs of the Project SWPPP.
 5. Preserve existing vegetation within all designated construction areas in accordance with BMP 4-01.
 6. Track-out shall be removed at the end of every business day and as frequently as necessary to keep adjacent roads clean and free of sediment.
 7. Dust control shall be implemented as necessary during construction in accordance with dust (wind erosion) control Bmp 4-08.
 8. All trash containers are required to be covered at all times.
 9. Additional SWPPP BMPs shall be implemented as dictated by site conditions and as recommended by the QSP to prevent erosion and pollutant transport.
 10. Erosion and sediment control BMP implementation at sites accessed by helicopter will be determined in the field by the QSP.



**Site Map
TL682
Map 22 of 49**

**Cleveland National Forest
Power Line Replacement Projects**

LUP TYPE I PROJECT

-  Fiber Roll (BMP 1-03)
-  Existing Velocity Dissipater
-  Existing Water Bar with Velocity Dissipater
-  Contour, 20-ft Interval
-  Wood-to-Steel Replacement
-  Wood-to-Steel Replacement
-  Anchor Work Area
-  Temp Access/Entry/Turnaround
-  Temp Pole Work Area
-  RFS Anchor
-  Footpath
-  Maintained Access Road
-  U.S. Forest Service

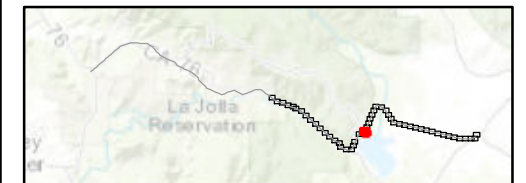

- SWPPP Notes:
1. Locations of SWPPP BMPs are not to scale.
 2. SWPPP BMP locations are conceptual in nature and must be field-verified prior to construction.
 3. Erosion and sediment controls shall be deployed prior to pavement or soil disturbance (where applicable) and as recommended by the QSP.
 4. SDG&E BMP Details for sediment controls, erosion controls, waste management controls, and non-storm water discharge controls are contained within Appendix XI Construction BMPs of the Project SWPPP.
 5. Preserve existing vegetation within all designated construction areas in accordance with BMP 4-01.
 6. Track-out shall be removed at the end of every business day and as frequently as necessary to keep adjacent roads clean and free of sediment.
 7. Dust control shall be implemented as necessary during construction in accordance with dust (wind erosion) control Bmp 4-08.
 8. All trash containers are required to be covered at all times.
 9. Additional SWPPP BMPs shall be implemented as dictated by site conditions and as recommended by the QSP to prevent erosion and pollutant transport.
 10. Erosion and sediment control BMP implementation at sites accessed by helicopter will be determined in the field by the QSP.

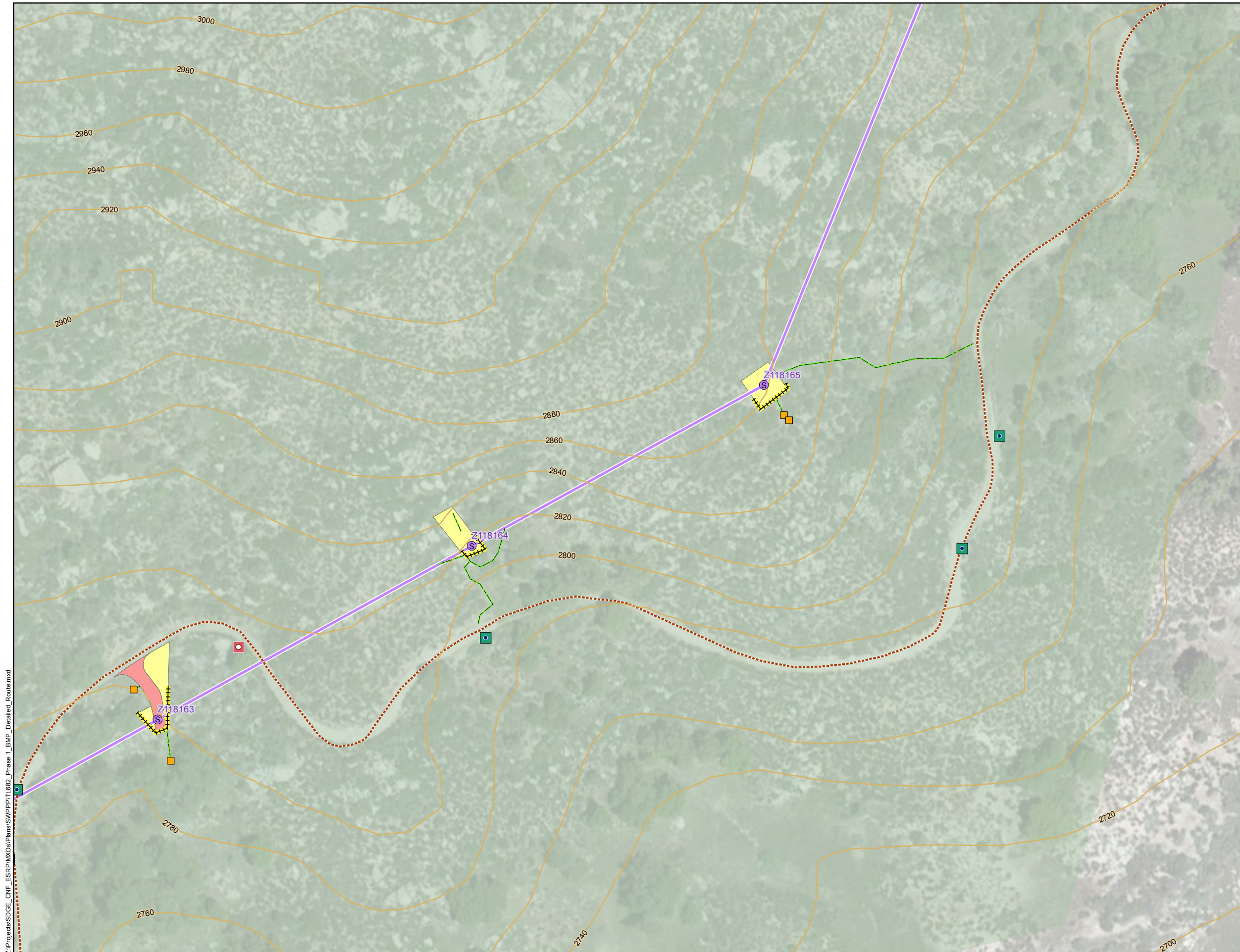
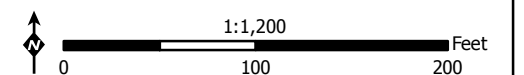













Z:\Projects\SDGE_CNF_ESR\IMX\Plans\SWPPP\TL682_Phase 1_BMP_Detailed_Route.mxd

**Site Map
TL682
Map 23 of 49**

**Cleveland National Forest
Power Line Replacement Projects**

LUP TYPE I PROJECT

-  Fiber Roll (BMP 1-03)
-  Existing Water Bar with Velocity Dissipater
-  Contour, 20-ft Interval
-  Pending
-  Wood-to-Steel Replacement
-  Wood-to-Steel Replacement
-  Anchor Work Area
-  Temp Pole Work Area
-  RFS Anchor
-  Construction Access Only
-  Footpath
-  Maintained Access Road
-  U.S. Forest Service

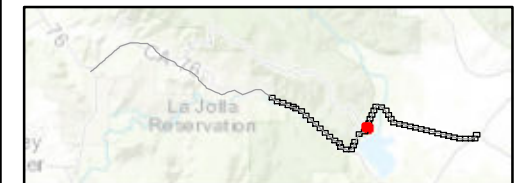

- SWPPP Notes:**
1. Locations of SWPPP BMPs are not to scale.
 2. SWPPP BMP locations are conceptual in nature and must be field-verified prior to construction.
 3. Erosion and sediment controls shall be deployed prior to pavement or soil disturbance (where applicable) and as recommended by the QSP.
 4. SDG&E BMP Details for sediment controls, erosion controls, waste management controls, and non-storm water discharge controls are contained within Appendix XI Construction BMPs of the Project SWPPP.
 5. Preserve existing vegetation within all designated construction areas in accordance with BMP 4-01.
 6. Track-out shall be removed at the end of every business day and as frequently as necessary to keep adjacent roads clean and free of sediment.
 7. Dust control shall be implemented as necessary during construction in accordance with dust (wind erosion) control Bmp 4-08.
 8. All trash containers are required to be covered at all times.
 9. Additional SWPPP BMPs shall be implemented as dictated by site conditions and as recommended by the QSP to prevent erosion and pollutant transport.
 10. Erosion and sediment control BMP implementation at sites accessed by helicopter will be determined in the field by the QSP.

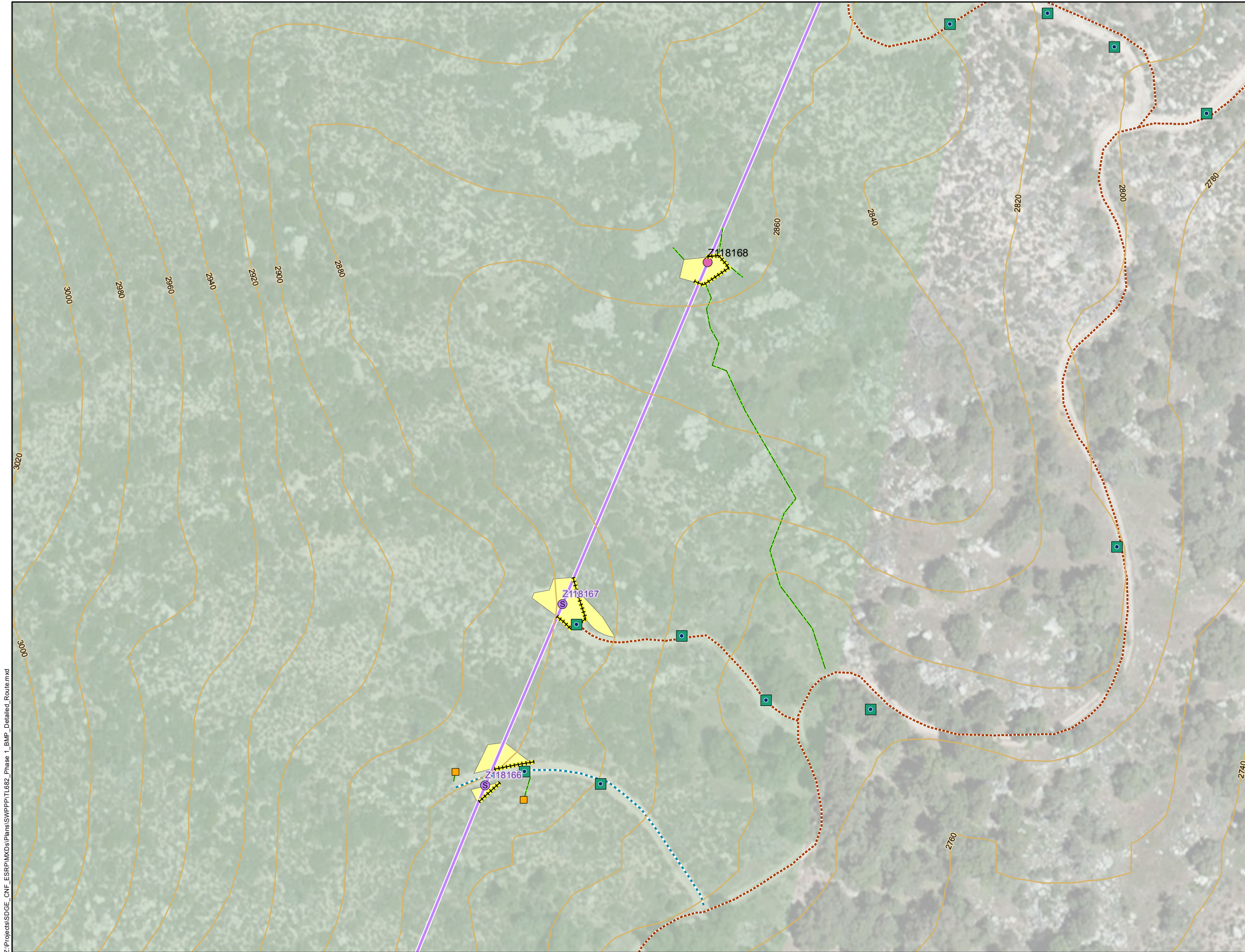
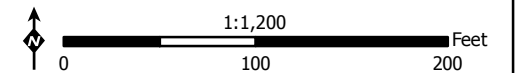











Z:\Projects\SDGE_CNF_ESR\IMX\Plans\SWPPP\TL682_Phase 1_BMP_Detailed_Route.mxd

**Site Map
TL682
Map 24 of 49**

**Cleveland National Forest
Power Line Replacement Projects**

LUP TYPE I PROJECT

-  Fiber Roll (BMP 1-03)
-  Existing Water Bar with Velocity Dissipater
-  Contour, 20-ft Interval
-  Wood-to-Steel Replacement
-  Wood-to-Steel Replacement
-  Anchor Work Area
-  Temp Pole Work Area
-  RFS Anchor
-  Footpath
-  Maintained Access Road
-  U.S. Forest Service

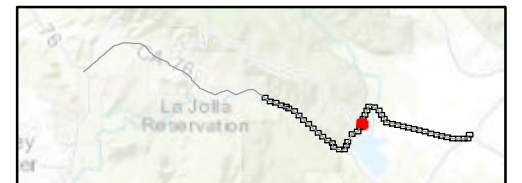

- SWPPP Notes:**
1. Locations of SWPPP BMPs are not to scale.
 2. SWPPP BMP locations are conceptual in nature and must be field-verified prior to construction.
 3. Erosion and sediment controls shall be deployed prior to pavement or soil disturbance (where applicable) and as recommended by the QSP.
 4. SDG&E BMP Details for sediment controls, erosion controls, waste management controls, and non-storm water discharge controls are contained within Appendix XI Construction BMPs of the Project SWPPP.
 5. Preserve existing vegetation within all designated construction areas in accordance with BMP 4-01.
 6. Track-out shall be removed at the end of every business day and as frequently as necessary to keep adjacent roads clean and free of sediment.
 7. Dust control shall be implemented as necessary during construction in accordance with dust (wind erosion) control Bmp 4-08.
 8. All trash containers are required to be covered at all times.
 9. Additional SWPPP BMPs shall be implemented as dictated by site conditions and as recommended by the QSP to prevent erosion and pollutant transport.
 10. Erosion and sediment control BMP implementation at sites accessed by helicopter will be determined in the field by the QSP.

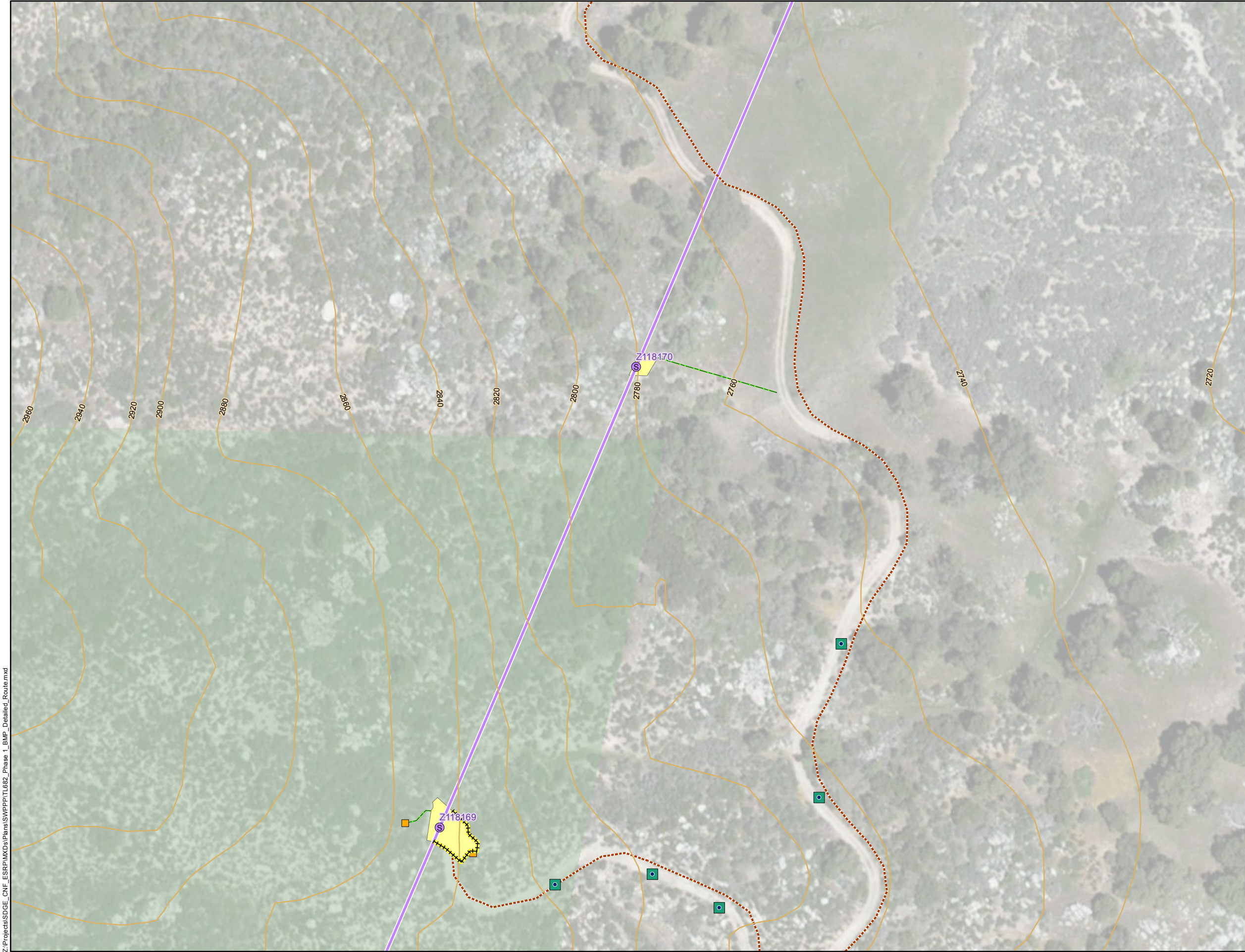
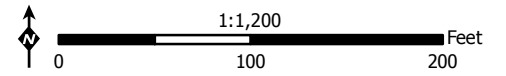













Z:\Projects\SDGE_CNF_ESRP\WXData\Plans\SWPPP\TL682_Phase 1_BMP_Detailed_Route.mxd

**Site Map
TL682
Map 25 of 49**

**Cleveland National Forest
Power Line Replacement Projects**

LUP TYPE I PROJECT

-  Fiber Roll (BMP 1-03)
-  Existing Velocity Dissipater
-  Existing Water Bar with Velocity Dissipater
-  Stream and Flow Direction
-  Contour, 20-ft Interval
-  Wood-to-Steel Replacement
-  Wood-to-Steel Replacement
-  Anchor Work Area
-  Temp Pole Work Area
-  RFS Anchor
-  Footpath
-  Maintained Access Road
-  Navigation Access Road

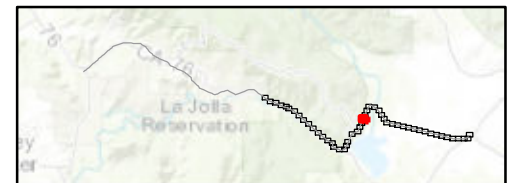

- SWPPP Notes:**
1. Locations of SWPPP BMPs are not to scale.
 2. SWPPP BMP locations are conceptual in nature and must be field-verified prior to construction.
 3. Erosion and sediment controls shall be deployed prior to pavement or soil disturbance (where applicable) and as recommended by the QSP.
 4. SDG&E BMP Details for sediment controls, erosion controls, waste management controls, and non-storm water discharge controls are contained within Appendix XI Construction BMPs of the Project SWPPP.
 5. Preserve existing vegetation within all designated construction areas in accordance with BMP 4-01.
 6. Track-out shall be removed at the end of every business day and as frequently as necessary to keep adjacent roads clean and free of sediment.
 7. Dust control shall be implemented as necessary during construction in accordance with dust (wind erosion) control Bmp 4-08.
 8. All trash containers are required to be covered at all times.
 9. Additional SWPPP BMPs shall be implemented as dictated by site conditions and as recommended by the QSP to prevent erosion and pollutant transport.
 10. Erosion and sediment control BMP implementation at sites accessed by helicopter will be determined in the field by the QSP.

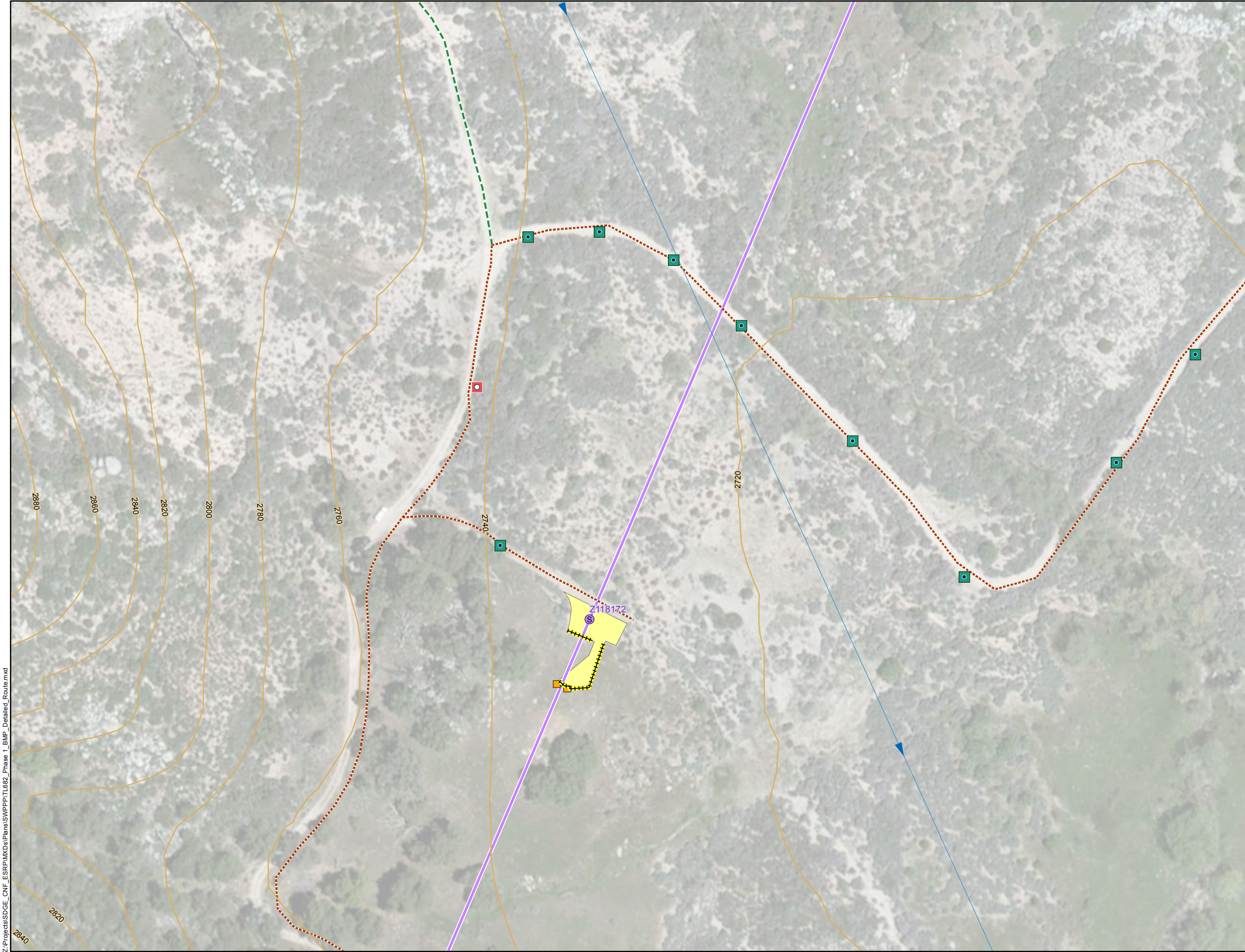
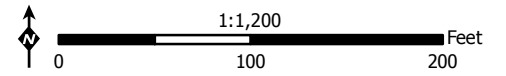













Z:\Projects\SDGE_CNF_ESRP\MXData\Plans\SWPPP\TL682_Phase 1_BMP_Detailed_Route.mxd

**Site Map
TL682
Map 26 of 49**

**Cleveland National Forest
Power Line Replacement Projects**

LUP TYPE I PROJECT

-  Fiber Roll (BMP 1-03)
-  Existing Water Bar with Velocity Dissipater
-  Stream and Flow Direction
-  Contour, 20-ft Interval
-  Wood-to-Steel Replacement
-  Wood-to-Steel Replacement
-  Anchor Work Area
-  Temp Pole Work Area
-  RFS Anchor
-  Construction Access Only
-  Footpath
-  Maintained Access Road
-  Navigation Access Road

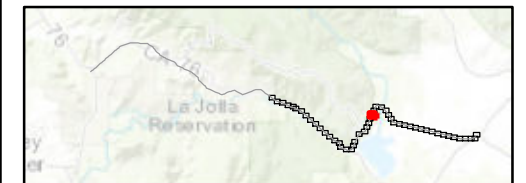

- SWPPP Notes:
1. Locations of SWPPP BMPs are not to scale.
 2. SWPPP BMP locations are conceptual in nature and must be field-verified prior to construction.
 3. Erosion and sediment controls shall be deployed prior to pavement or soil disturbance (where applicable) and as recommended by the QSP.
 4. SDG&E BMP Details for sediment controls, erosion controls, waste management controls, and non-storm water discharge controls are contained within Appendix XI Construction BMPs of the Project SWPPP.
 5. Preserve existing vegetation within all designated construction areas in accordance with BMP 4-01.
 6. Track-out shall be removed at the end of every business day and as frequently as necessary to keep adjacent roads clean and free of sediment.
 7. Dust control shall be implemented as necessary during construction in accordance with dust (wind erosion) control Bmp 4-08.
 8. All trash containers are required to be covered at all times.
 9. Additional SWPPP BMPs shall be implemented as dictated by site conditions and as recommended by the QSP to prevent erosion and pollutant transport.
 10. Erosion and sediment control BMP implementation at sites accessed by helicopter will be determined in the field by the QSP.

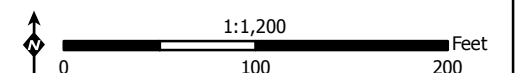











Z:\Projects\SDGE_CNF_ESRP\MXData\Plans\SWPPP\TL682_Phase 1_BMP_Detailed_Route.mxd

**Site Map
TL682
Map 27 of 49**

**Cleveland National Forest
Power Line Replacement Projects**

LUP TYPE I PROJECT

-  Fiber Roll (BMP 1-03)
-  Existing Water Bar with Velocity Dissipater
-  Contour, 20-ft Interval
-  Wood-to-Steel Replacement
-  Wood-to-Steel Replacement
-  Anchor Work Area
-  Temp Pole Work Area
-  RFS Anchor
-  Footpath
-  Maintained Access Road
-  Navigation Access Road

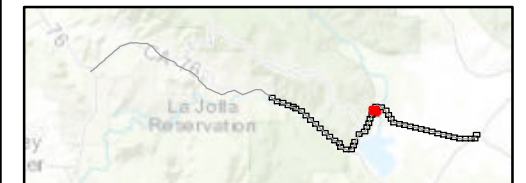

- SWPPP Notes:**
1. Locations of SWPPP BMPs are not to scale.
 2. SWPPP BMP locations are conceptual in nature and must be field-verified prior to construction.
 3. Erosion and sediment controls shall be deployed prior to pavement or soil disturbance (where applicable) and as recommended by the QSP.
 4. SDG&E BMP Details for sediment controls, erosion controls, waste management controls, and non-storm water discharge controls are contained within Appendix XI Construction BMPs of the Project SWPPP.
 5. Preserve existing vegetation within all designated construction areas in accordance with BMP 4-01.
 6. Track-out shall be removed at the end of every business day and as frequently as necessary to keep adjacent roads clean and free of sediment.
 7. Dust control shall be implemented as necessary during construction in accordance with dust (wind erosion) control Bmp 4-08.
 8. All trash containers are required to be covered at all times.
 9. Additional SWPPP BMPs shall be implemented as dictated by site conditions and as recommended by the QSP to prevent erosion and pollutant transport.
 10. Erosion and sediment control BMP implementation at sites accessed by helicopter will be determined in the field by the QSP.

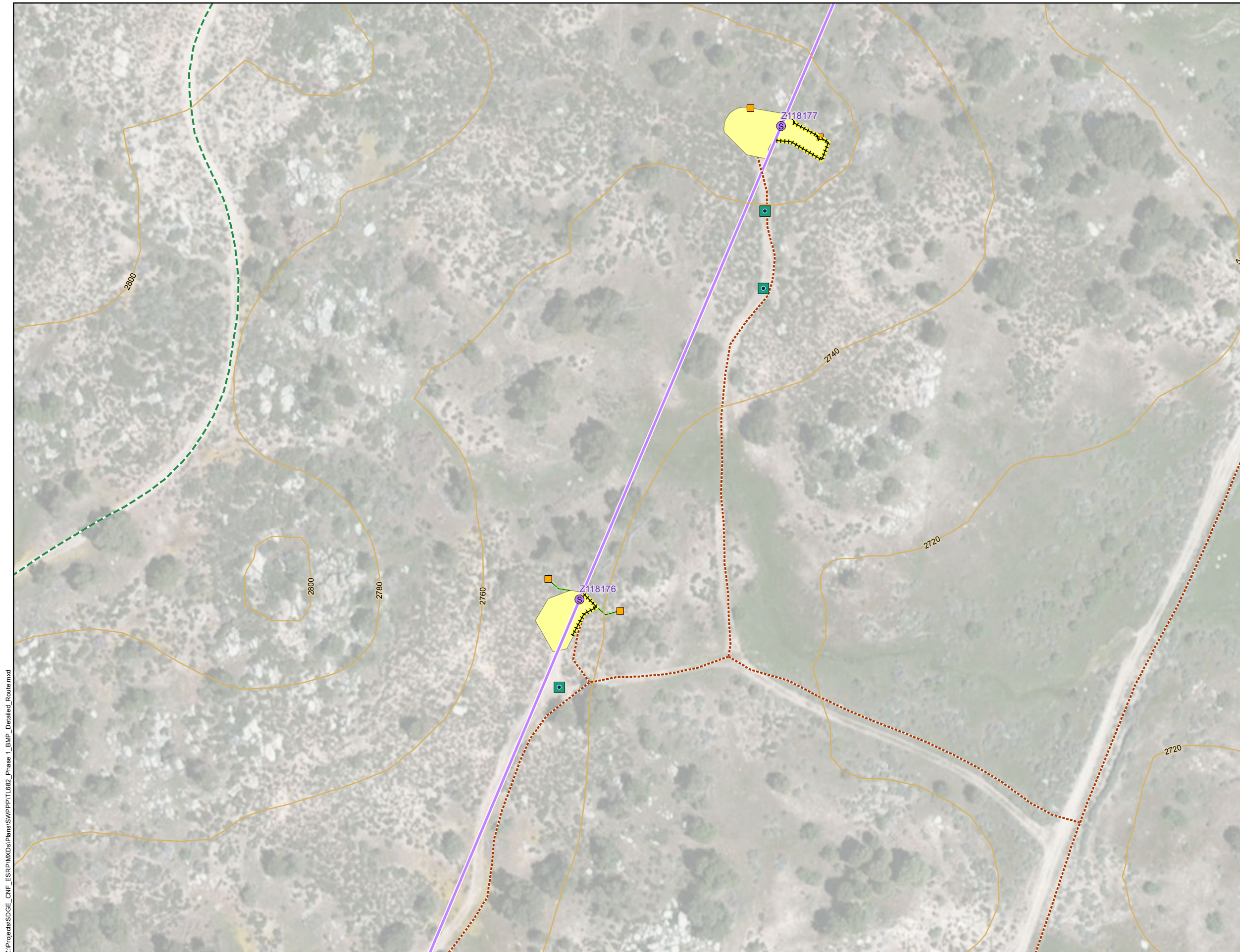
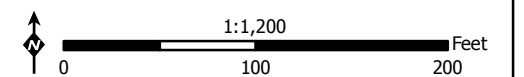

Z:\Projects\SDGE_CNF_ESR\MXData\Plans\SWPPP\TL682_Phase 1_BMP_Detailed_Route.mxd

**Site Map
TL682
Map 28 of 49**

**Cleveland National Forest
Power Line Replacement Projects**

LUP TYPE I PROJECT

-  Fiber Roll (BMP 1-03)
-  Existing Water Bar
-  Existing Water Bar with Velocity Dissipater
-  Stream and Flow Direction
-  Contour, 20-ft Interval
-  Wood-to-Steel Replacement
-  Wood-to-Steel Replacement
-  Anchor Work Area
-  Stringing Site
-  Temp Pole Work Area
-  RFS Anchor
-  Footpath
-  Maintained Access Road
-  Navigation Access Road

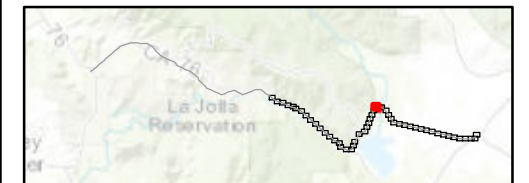

SWPPP Notes:

1. Locations of SWPPP BMPs are not to scale.
2. SWPPP BMP locations are conceptual in nature and must be field-verified prior to construction.
3. Erosion and sediment controls shall be deployed prior to pavement or soil disturbance (where applicable) and as recommended by the QSP.
4. SDG&E BMP Details for sediment controls, erosion controls, waste management controls, and non-storm water discharge controls are contained within Appendix XI Construction BMPs of the Project SWPPP.
5. Preserve existing vegetation within all designated construction areas in accordance with BMP 4-01.
6. Track-out shall be removed at the end of every business day and as frequently as necessary to keep adjacent roads clean and free of sediment.
7. Dust control shall be implemented as necessary during construction in accordance with dust (wind erosion) control Bmp 4-08.
8. All trash containers are required to be covered at all times.
9. Additional SWPPP BMPs shall be implemented as dictated by site conditions and as recommended by the QSP to prevent erosion and pollutant transport.
10. Erosion and sediment control BMP implementation at sites accessed by helicopter will be determined in the field by the QSP.

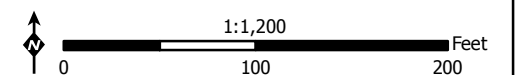













Z:\Projects\SDGE_CNF_ESRP\MXDs\Plans\SWPPP\TL682_Phase I_BMP_Detailed_Route.mxd

**Site Map
TL682
Map 29 of 49**

**Cleveland National Forest
Power Line Replacement Projects**

LUP TYPE I PROJECT

-  Fiber Roll (BMP 1-03)
-  Existing Water Bar
-  Stream and Flow Direction
-  Contour, 20-ft Interval
-  Wood-to-Steel Replacement
-  Wood-to-Steel Replacement
-  Anchor Work Area
-  Temp Pole Work Area
-  RFS Anchor
-  Footpath
-  Maintained Access Road
-  Navigation Access Road

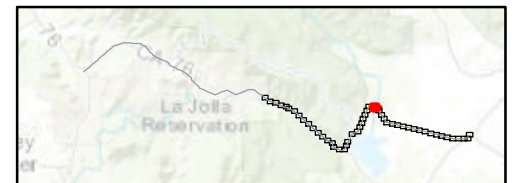

- SWPPP Notes:
1. Locations of SWPPP BMPs are not to scale.
 2. SWPPP BMP locations are conceptual in nature and must be field-verified prior to construction.
 3. Erosion and sediment controls shall be deployed prior to pavement or soil disturbance (where applicable) and as recommended by the QSP.
 4. SDG&E BMP Details for sediment controls, erosion controls, waste management controls, and non-storm water discharge controls are contained within Appendix XI Construction BMPs of the Project SWPPP.
 5. Preserve existing vegetation within all designated construction areas in accordance with BMP 4-01.
 6. Track-out shall be removed at the end of every business day and as frequently as necessary to keep adjacent roads clean and free of sediment.
 7. Dust control shall be implemented as necessary during construction in accordance with dust (wind erosion) control Bmp 4-08.
 8. All trash containers are required to be covered at all times.
 9. Additional SWPPP BMPs shall be implemented as dictated by site conditions and as recommended by the QSP to prevent erosion and pollutant transport.
 10. Erosion and sediment control BMP implementation at sites accessed by helicopter will be determined in the field by the QSP.

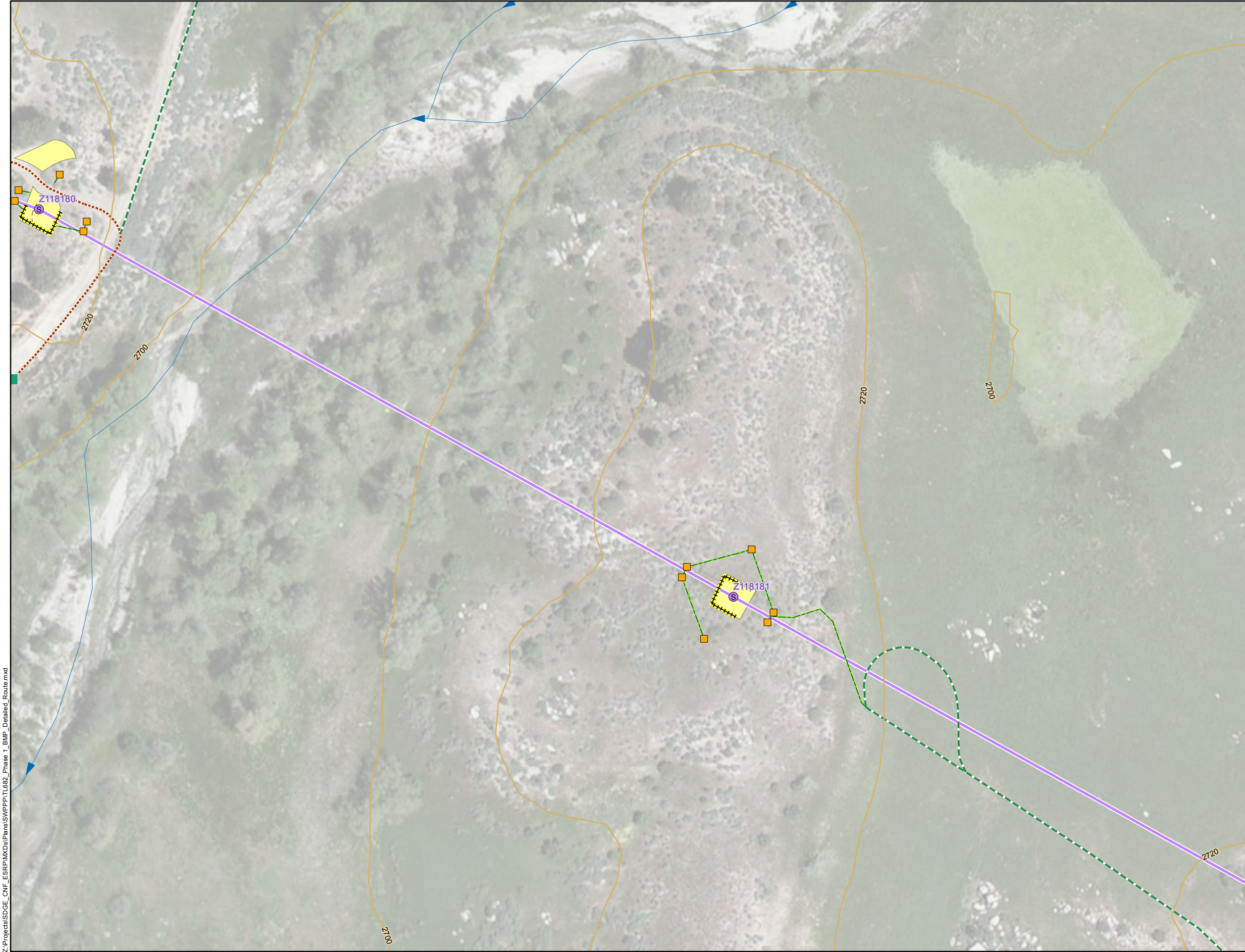
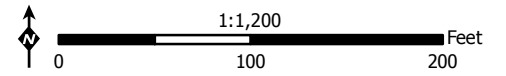











Z:\Projects\SDGE_CNF_ESRP\MXData\Plans\SWPPP\TL682_Phase 1_BMP_Detailed_Route.mxd

**Site Map
TL682
Map 30 of 49**

**Cleveland National Forest
Power Line Replacement Projects**

LUP TYPE I PROJECT

-  Fiber Roll (BMP 1-03)
-  Contour, 20-ft Interval
-  Wood-to-Steel Replacement
-  Wood-to-Steel Replacement
-  Anchor Work Area
-  Stringing Site
-  Temp Pole Work Area
-  RFS Anchor
-  Construction Access Only
-  Footpath
-  Navigation Access Road

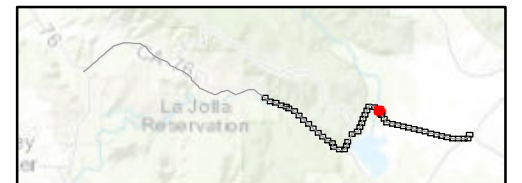



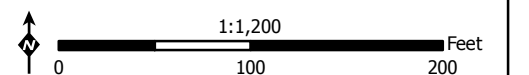



- SWPPP Notes:**
1. Locations of SWPPP BMPs are not to scale.
 2. SWPPP BMP locations are conceptual in nature and must be field-verified prior to construction.
 3. Erosion and sediment controls shall be deployed prior to pavement or soil disturbance (where applicable) and as recommended by the QSP.
 4. SDG&E BMP Details for sediment controls, erosion controls, waste management controls, and non-storm water discharge controls are contained within Appendix XI Construction BMPs of the Project SWPPP.
 5. Preserve existing vegetation within all designated construction areas in accordance with BMP 4-01.
 6. Track-out shall be removed at the end of every business day and as frequently as necessary to keep adjacent roads clean and free of sediment.
 7. Dust control shall be implemented as necessary during construction in accordance with dust (wind erosion) control Bmp 4-08.
 8. All trash containers are required to be covered at all times.
 9. Additional SWPPP BMPs shall be implemented as dictated by site conditions and as recommended by the QSP to prevent erosion and pollutant transport.
 10. Erosion and sediment control BMP implementation at sites accessed by helicopter will be determined in the field by the QSP.



Site Map
TL682
Map 31 of 49

Cleveland National Forest
Power Line Replacement Projects

LUP TYPE I PROJECT

-  Fiber Roll (BMP 1-03)
-  Contour, 20-ft Interval
-  Wood-to-Steel Replacement
-  Wood-to-Steel Replacement
-  Temp Access/Entry/Turnaround
-  Temp Pole Work Area
-  Navigation Access Road

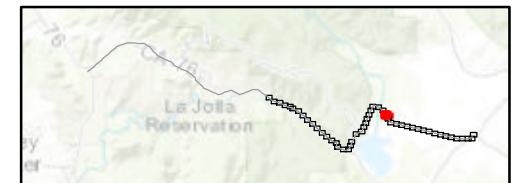

- SWPPP Notes:
1. Locations of SWPPP BMPs are not to scale.
 2. SWPPP BMP locations are conceptual in nature and must be field-verified prior to construction.
 3. Erosion and sediment controls shall be deployed prior to pavement or soil disturbance (where applicable) and as recommended by the QSP.
 4. SDG&E BMP Details for sediment controls, erosion controls, waste management controls, and non-storm water discharge controls are contained within Appendix XI Construction BMPs of the Project SWPPP.
 5. Preserve existing vegetation within all designated construction areas in accordance with BMP 4-01.
 6. Track-out shall be removed at the end of every business day and as frequently as necessary to keep adjacent roads clean and free of sediment.
 7. Dust control shall be implemented as necessary during construction in accordance with dust (wind erosion) control Bmp 4-08.
 8. All trash containers are required to be covered at all times.
 9. Additional SWPPP BMPs shall be implemented as dictated by site conditions and as recommended by the QSP to prevent erosion and pollutant transport.
 10. Erosion and sediment control BMP implementation at sites accessed by helicopter will be determined in the field by the QSP.

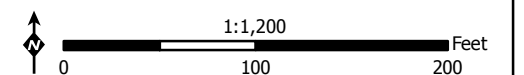











Z:\Projects\SDGE_CNF_ESRPI\XData\Plans\SWPPP\TL682_Phase 1_BMP_Detailed_Route.mxd

**Site Map
TL682
Map 32 of 49**

**Cleveland National Forest
Power Line Replacement Projects**

LUP TYPE I PROJECT

-  Fiber Roll (BMP 1-03)
-  Contour, 20-ft Interval
-  Wood-to-Steel Replacement
-  Wood-to-Steel Replacement
-  Anchor Work Area
-  Stringing Site
-  Temp Pole Work Area
-  RFS Anchor
-  Footpath
-  Navigation Access Road

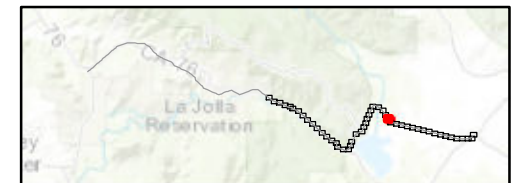

- SWPPP Notes:**
1. Locations of SWPPP BMPs are not to scale.
 2. SWPPP BMP locations are conceptual in nature and must be field-verified prior to construction.
 3. Erosion and sediment controls shall be deployed prior to pavement or soil disturbance (where applicable) and as recommended by the QSP.
 4. SDG&E BMP Details for sediment controls, erosion controls, waste management controls, and non-storm water discharge controls are contained within Appendix XI Construction BMPs of the Project SWPPP.
 5. Preserve existing vegetation within all designated construction areas in accordance with BMP 4-01.
 6. Track-out shall be removed at the end of every business day and as frequently as necessary to keep adjacent roads clean and free of sediment.
 7. Dust control shall be implemented as necessary during construction in accordance with dust (wind erosion) control Bmp 4-08.
 8. All trash containers are required to be covered at all times.
 9. Additional SWPPP BMPs shall be implemented as dictated by site conditions and as recommended by the QSP to prevent erosion and pollutant transport.
 10. Erosion and sediment control BMP implementation at sites accessed by helicopter will be determined in the field by the QSP.

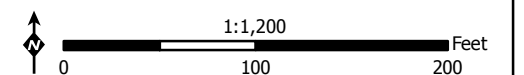











Z:\Projects\SDGE_CNF_ESRP\MXData\Plans\SWPPP\TL682_Phase 1_BMP_Detailed_Route.mxd

**Site Map
TL682
Map 33 of 49**

**Cleveland National Forest
Power Line Replacement Projects**

LUP TYPE I PROJECT

-  Fiber Roll (BMP 1-03)
-  Contour, 20-ft Interval
-  Wood-to-Steel Replacement
-  Wood-to-Steel Replacement
-  Anchor Work Area
-  Stringing Site
-  Temp Pole Work Area
-  RFS Anchor
-  Footpath
-  Navigation Access Road

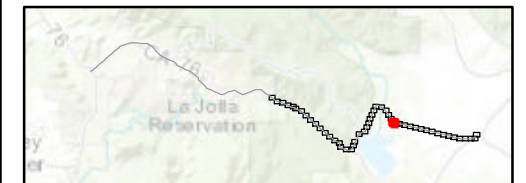

- SWPPP Notes:**
1. Locations of SWPPP BMPs are not to scale.
 2. SWPPP BMP locations are conceptual in nature and must be field-verified prior to construction.
 3. Erosion and sediment controls shall be deployed prior to pavement or soil disturbance (where applicable) and as recommended by the QSP.
 4. SDG&E BMP Details for sediment controls, erosion controls, waste management controls, and non-storm water discharge controls are contained within Appendix XI Construction BMPs of the Project SWPPP.
 5. Preserve existing vegetation within all designated construction areas in accordance with BMP 4-01.
 6. Track-out shall be removed at the end of every business day and as frequently as necessary to keep adjacent roads clean and free of sediment.
 7. Dust control shall be implemented as necessary during construction in accordance with dust (wind erosion) control Bmp 4-08.
 8. All trash containers are required to be covered at all times.
 9. Additional SWPPP BMPs shall be implemented as dictated by site conditions and as recommended by the QSP to prevent erosion and pollutant transport.
 10. Erosion and sediment control BMP implementation at sites accessed by helicopter will be determined in the field by the QSP.

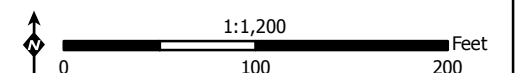











Z:\Projects\SDGE_CNF_ESR\MXDs\Plans\SWPPP\TL682_Phase 1_BMP_Detailed_Route.mxd

**Site Map
TL682
Map 34 of 49**

**Cleveland National Forest
Power Line Replacement Projects**

LUP TYPE I PROJECT

-  Fiber Roll (BMP 1-03)
-  Contour, 20-ft Interval
-  Wood-to-Steel Replacement
-  Wood-to-Steel Replacement
-  Anchor Work Area
-  Temp Access/Entry/Turnaround
-  Temp Pole Work Area
-  RFS Anchor
-  Footpath
-  Navigation Access Road

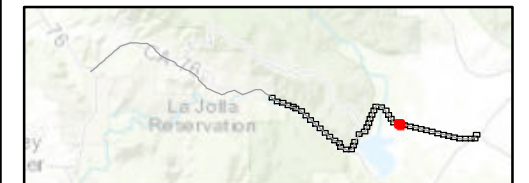

SWPPP Notes:

1. Locations of SWPPP BMPs are not to scale.
2. SWPPP BMP locations are conceptual in nature and must be field-verified prior to construction.
3. Erosion and sediment controls shall be deployed prior to pavement or soil disturbance (where applicable) and as recommended by the QSP.
4. SDG&E BMP Details for sediment controls, erosion controls, waste management controls, and non-storm water discharge controls are contained within Appendix XI Construction BMPs of the Project SWPPP.
5. Preserve existing vegetation within all designated construction areas in accordance with BMP 4-01.
6. Track-out shall be removed at the end of every business day and as frequently as necessary to keep adjacent roads clean and free of sediment.
7. Dust control shall be implemented as necessary during construction in accordance with dust (wind erosion) control Bmp 4-08.
8. All trash containers are required to be covered at all times.
9. Additional SWPPP BMPs shall be implemented as dictated by site conditions and as recommended by the QSP to prevent erosion and pollutant transport.
10. Erosion and sediment control BMP implementation at sites accessed by helicopter will be determined in the field by the QSP.

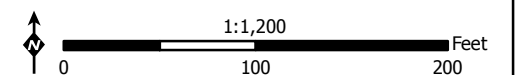





Z:\Projects\SDGE_CNF_ESRP\MXData\Plans\SWPPP\TL682_Phase I_BMP_Detailed_Route.mxd

**Site Map
TL682
Map 35 of 49**

**Cleveland National Forest
Power Line Replacement Projects**

LUP TYPE I PROJECT

-  Fiber Roll (BMP 1-03)
-  Gravel Bag Berm (BMP 1-04)
-  Contour, 20-ft Interval
-  Wood-to-Steel Replacement
-  Wood-to-Steel Replacement
-  Temp Access/Entry/Turnaround
-  Temp Pole Work Area
-  Navigation Access Road

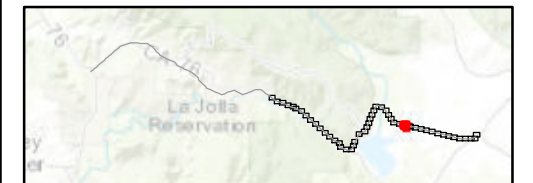



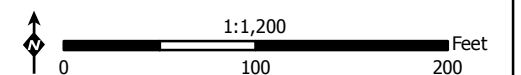



- SWPPP Notes:**
1. Locations of SWPPP BMPs are not to scale.
 2. SWPPP BMP locations are conceptual in nature and must be field-verified prior to construction.
 3. Erosion and sediment controls shall be deployed prior to pavement or soil disturbance (where applicable) and as recommended by the QSP.
 4. SDG&E BMP Details for sediment controls, erosion controls, waste management controls, and non-storm water discharge controls are contained within Appendix XI Construction BMPs of the Project SWPPP.
 5. Preserve existing vegetation within all designated construction areas in accordance with BMP 4-01.
 6. Track-out shall be removed at the end of every business day and as frequently as necessary to keep adjacent roads clean and free of sediment.
 7. Dust control shall be implemented as necessary during construction in accordance with dust (wind erosion) control Bmp 4-08.
 8. All trash containers are required to be covered at all times.
 9. Additional SWPPP BMPs shall be implemented as dictated by site conditions and as recommended by the QSP to prevent erosion and pollutant transport.
 10. Erosion and sediment control BMP implementation at sites accessed by helicopter will be determined in the field by the QSP.



**Site Map
TL682
Map 36 of 49**

**Cleveland National Forest
Power Line Replacement Projects**

LUP TYPE I PROJECT

-  Fiber Roll (BMP 1-03)
-  Contour, 20-ft Interval
-  Wood-to-Steel Replacement
-  Wood-to-Steel Replacement
-  Temp Pole Work Area
-  Navigation Access Road

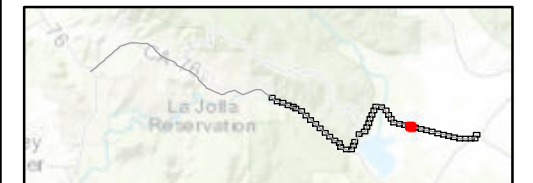

SWPPP Notes:



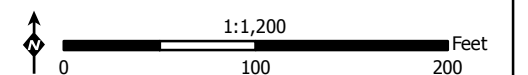



1. Locations of SWPPP BMPs are not to scale.
2. SWPPP BMP locations are conceptual in nature and must be field-verified prior to construction.
3. Erosion and sediment controls shall be deployed prior to pavement or soil disturbance (where applicable) and as recommended by the QSP.
4. SDG&E BMP Details for sediment controls, erosion controls, waste management controls, and non-storm water discharge controls are contained within Appendix XI Construction BMPs of the Project SWPPP.
5. Preserve existing vegetation within all designated construction areas in accordance with BMP 4-01.
6. Track-out shall be removed at the end of every business day and as frequently as necessary to keep adjacent roads clean and free of sediment.
7. Dust control shall be implemented as necessary during construction in accordance with dust (wind erosion) control Bmp 4-08.
8. All trash containers are required to be covered at all times.
9. Additional SWPPP BMPs shall be implemented as dictated by site conditions and as recommended by the QSP to prevent erosion and pollutant transport.
10. Erosion and sediment control BMP implementation at sites accessed by helicopter will be determined in the field by the QSP.



**Site Map
TL682
Map 37 of 49**

**Cleveland National Forest
Power Line Replacement Projects**

LUP TYPE I PROJECT

-  Fiber Roll (BMP 1-03)
-  Stream and Flow Direction
-  Contour, 20-ft Interval
-  Wood-to-Steel Replacement
-  Wood-to-Steel Replacement
-  Temp Pole Work Area
-  Navigation Access Road

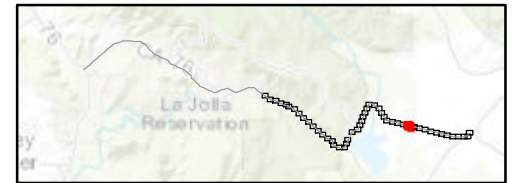



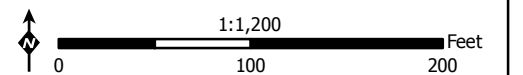



- SWPPP Notes:**
1. Locations of SWPPP BMPs are not to scale.
 2. SWPPP BMP locations are conceptual in nature and must be field-verified prior to construction.
 3. Erosion and sediment controls shall be deployed prior to pavement or soil disturbance (where applicable) and as recommended by the QSP.
 4. SDG&E BMP Details for sediment controls, erosion controls, waste management controls, and non-storm water discharge controls are contained within Appendix XI Construction BMPs of the Project SWPPP.
 5. Preserve existing vegetation within all designated construction areas in accordance with BMP 4-01.
 6. Track-out shall be removed at the end of every business day and as frequently as necessary to keep adjacent roads clean and free of sediment.
 7. Dust control shall be implemented as necessary during construction in accordance with dust (wind erosion) control Bmp 4-08.
 8. All trash containers are required to be covered at all times.
 9. Additional SWPPP BMPs shall be implemented as dictated by site conditions and as recommended by the QSP to prevent erosion and pollutant transport.
 10. Erosion and sediment control BMP implementation at sites accessed by helicopter will be determined in the field by the QSP.



**Site Map
TL682
Map 38 of 49**

**Cleveland National Forest
Power Line Replacement Projects**

LUP TYPE I PROJECT

-  Fiber Roll (BMP 1-03)
-  Stream and Flow Direction
-  Contour, 20-ft Interval
-  Wood-to-Steel Replacement
-  Wood-to-Steel Replacement
-  Temp Pole Work Area
-  Navigation Access Road

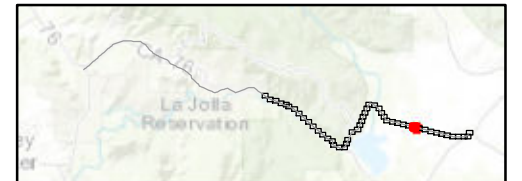
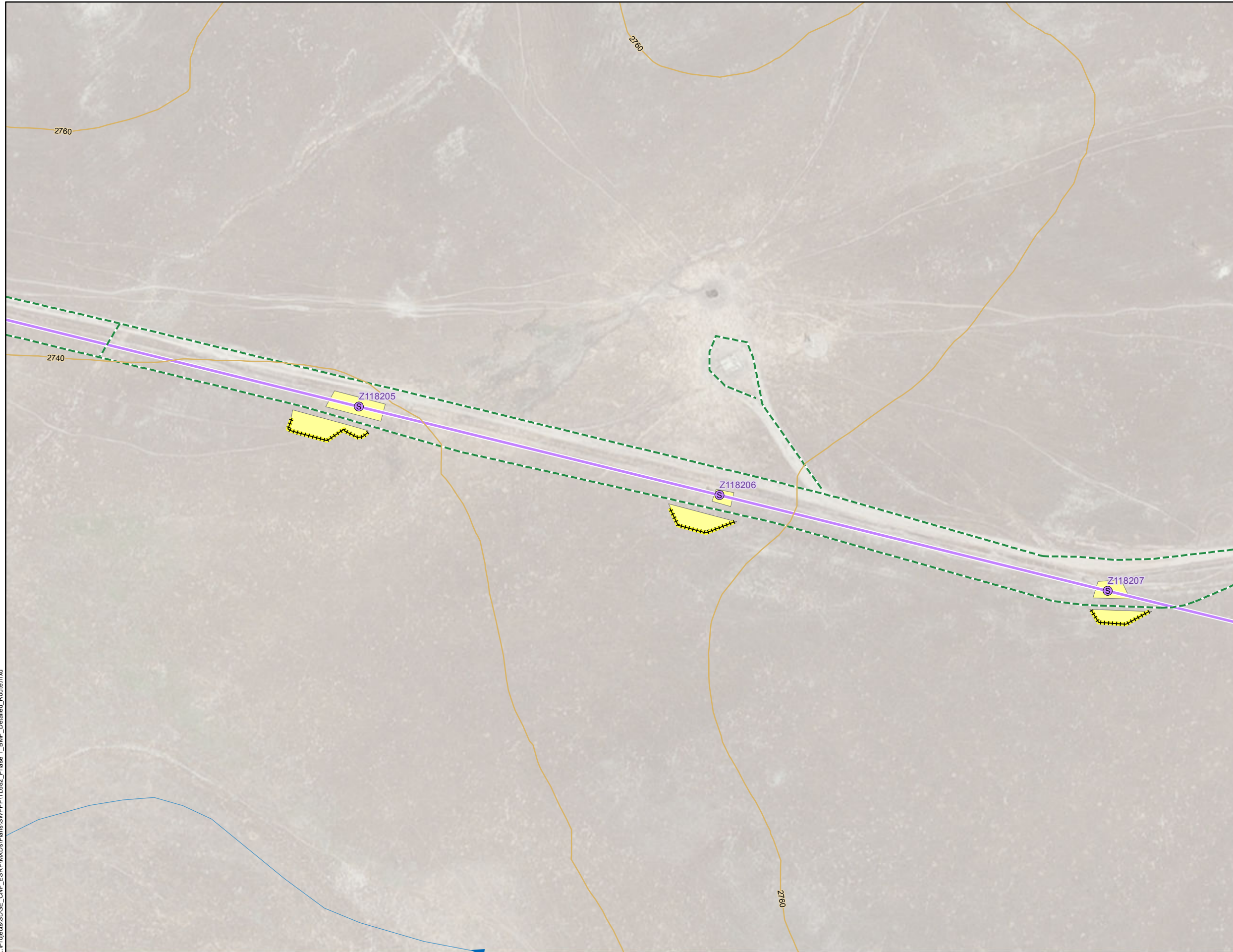



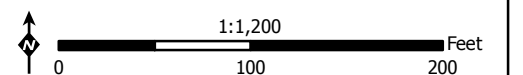





- SWPPP Notes:**
1. Locations of SWPPP BMPs are not to scale.
 2. SWPPP BMP locations are conceptual in nature and must be field-verified prior to construction.
 3. Erosion and sediment controls shall be deployed prior to pavement or soil disturbance (where applicable) and as recommended by the QSP.
 4. SDG&E BMP Details for sediment controls, erosion controls, waste management controls, and non-storm water discharge controls are contained within Appendix XI Construction BMPs of the Project SWPPP.
 5. Preserve existing vegetation within all designated construction areas in accordance with BMP 4-01.
 6. Track-out shall be removed at the end of every business day and as frequently as necessary to keep adjacent roads clean and free of sediment.
 7. Dust control shall be implemented as necessary during construction in accordance with dust (wind erosion) control Bmp 4-08.
 8. All trash containers are required to be covered at all times.
 9. Additional SWPPP BMPs shall be implemented as dictated by site conditions and as recommended by the QSP to prevent erosion and pollutant transport.
 10. Erosion and sediment control BMP implementation at sites accessed by helicopter will be determined in the field by the QSP.



**Site Map
TL682
Map 39 of 49**

**Cleveland National Forest
Power Line Replacement Projects**

LUP TYPE I PROJECT

-  Fiber Roll (BMP 1-03)
-  Silt Fence (BMP 1-02)
-  Stream and Flow Direction
-  Contour, 20-ft Interval
-  Wood-to-Steel Replacement
-  Wood-to-Steel Replacement
-  Temp Pole Work Area
-  Navigation Access Road

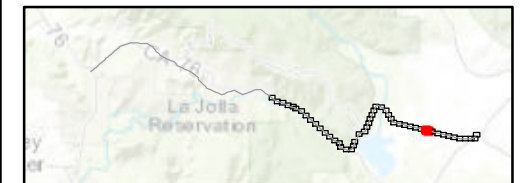
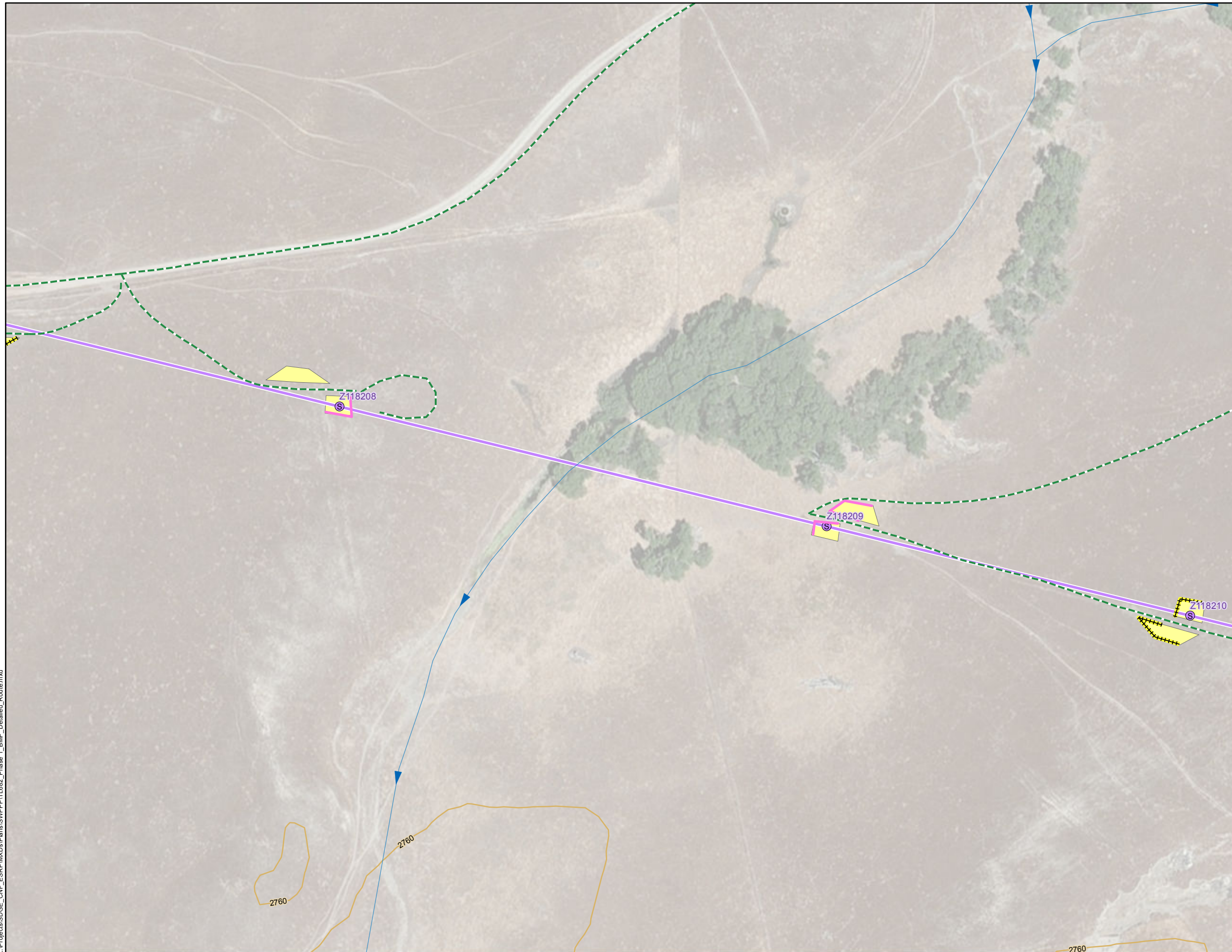



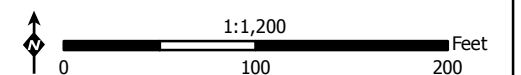



- SWPPP Notes:**
1. Locations of SWPPP BMPs are not to scale.
 2. SWPPP BMP locations are conceptual in nature and must be field-verified prior to construction.
 3. Erosion and sediment controls shall be deployed prior to pavement or soil disturbance (where applicable) and as recommended by the QSP.
 4. SDG&E BMP Details for sediment controls, erosion controls, waste management controls, and non-storm water discharge controls are contained within Appendix XI Construction BMPs of the Project SWPPP.
 5. Preserve existing vegetation within all designated construction areas in accordance with BMP 4-01.
 6. Track-out shall be removed at the end of every business day and as frequently as necessary to keep adjacent roads clean and free of sediment.
 7. Dust control shall be implemented as necessary during construction in accordance with dust (wind erosion) control Bmp 4-08.
 8. All trash containers are required to be covered at all times.
 9. Additional SWPPP BMPs shall be implemented as dictated by site conditions and as recommended by the QSP to prevent erosion and pollutant transport.
 10. Erosion and sediment control BMP implementation at sites accessed by helicopter will be determined in the field by the QSP.



**Site Map
TL682
Map 40 of 49**

**Cleveland National Forest
Power Line Replacement Projects**

LUP TYPE I PROJECT

-  Fiber Roll (BMP 1-03)
-  Contour, 20-ft Interval
-  Wood-to-Steel Replacement
-  Wood-to-Steel Replacement
-  Temp Pole Work Area
-  Footpath
-  Navigation Access Road

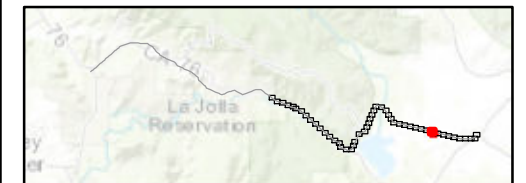
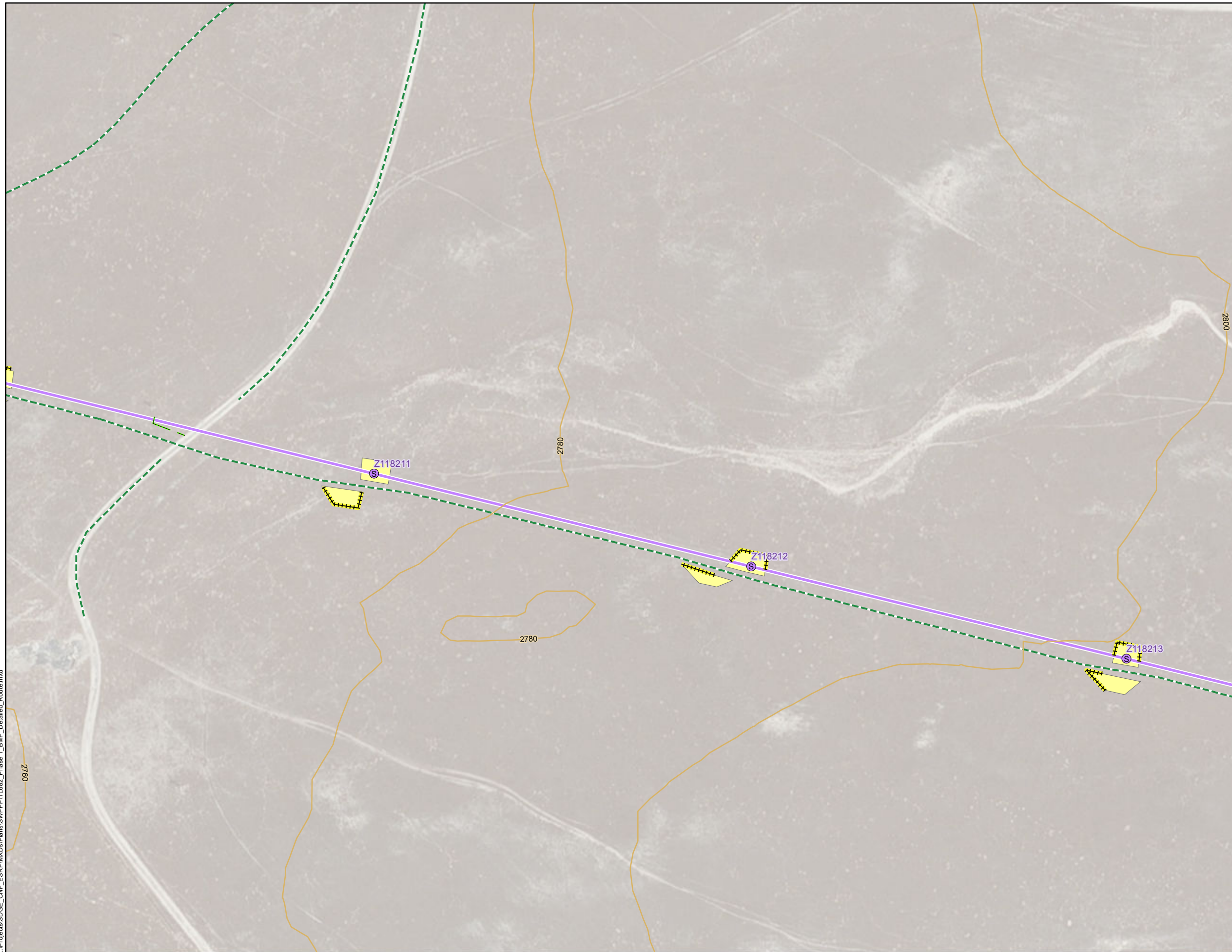

SWPPP Notes:



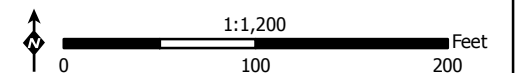



1. Locations of SWPPP BMPs are not to scale.
2. SWPPP BMP locations are conceptual in nature and must be field-verified prior to construction.
3. Erosion and sediment controls shall be deployed prior to pavement or soil disturbance (where applicable) and as recommended by the QSP.
4. SDG&E BMP Details for sediment controls, erosion controls, waste management controls, and non-storm water discharge controls are contained within Appendix XI Construction BMPs of the Project SWPPP.
5. Preserve existing vegetation within all designated construction areas in accordance with BMP 4-01.
6. Track-out shall be removed at the end of every business day and as frequently as necessary to keep adjacent roads clean and free of sediment.
7. Dust control shall be implemented as necessary during construction in accordance with dust (wind erosion) control Bmp 4-08.
8. All trash containers are required to be covered at all times.
9. Additional SWPPP BMPs shall be implemented as dictated by site conditions and as recommended by the QSP to prevent erosion and pollutant transport.
10. Erosion and sediment control BMP implementation at sites accessed by helicopter will be determined in the field by the QSP.



**Site Map
TL682
Map 41 of 49**

**Cleveland National Forest
Power Line Replacement Projects**

LUP TYPE I PROJECT

-  Fiber Roll (BMP 1-03)
-  Silt Fence (BMP 1-02)
-  Contour, 20-ft Interval
-  Wood-to-Steel Replacement
-  Wood-to-Steel Replacement
-  Temp Pole Work Area
-  Navigation Access Road

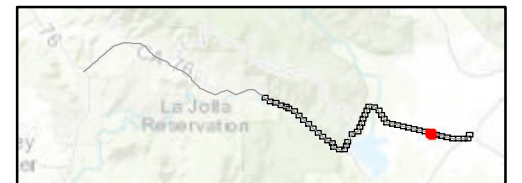



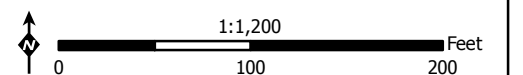



- SWPPP Notes:**
1. Locations of SWPPP BMPs are not to scale.
 2. SWPPP BMP locations are conceptual in nature and must be field-verified prior to construction.
 3. Erosion and sediment controls shall be deployed prior to pavement or soil disturbance (where applicable) and as recommended by the QSP.
 4. SDG&E BMP Details for sediment controls, erosion controls, waste management controls, and non-storm water discharge controls are contained within Appendix XI Construction BMPs of the Project SWPPP.
 5. Preserve existing vegetation within all designated construction areas in accordance with BMP 4-01.
 6. Track-out shall be removed at the end of every business day and as frequently as necessary to keep adjacent roads clean and free of sediment.
 7. Dust control shall be implemented as necessary during construction in accordance with dust (wind erosion) control Bmp 4-08.
 8. All trash containers are required to be covered at all times.
 9. Additional SWPPP BMPs shall be implemented as dictated by site conditions and as recommended by the QSP to prevent erosion and pollutant transport.
 10. Erosion and sediment control BMP implementation at sites accessed by helicopter will be determined in the field by the QSP.



Site Map
TL682
Map 42 of 49

Cleveland National Forest
Power Line Replacement Projects

LUP TYPE I PROJECT

-  Fiber Roll (BMP 1-03)
-  Contour, 20-ft Interval
-  Wood-to-Steel Replacement
-  Wood-to-Steel Replacement
-  Temp Pole Work Area
-  Navigation Access Road

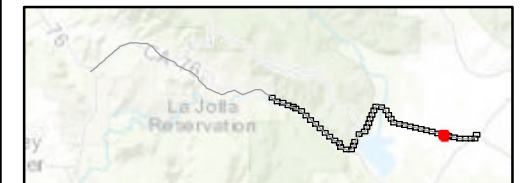



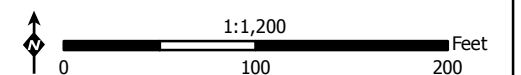



- SWPPP Notes:
1. Locations of SWPPP BMPs are not to scale.
 2. SWPPP BMP locations are conceptual in nature and must be field-verified prior to construction.
 3. Erosion and sediment controls shall be deployed prior to pavement or soil disturbance (where applicable) and as recommended by the QSP.
 4. SDG&E BMP Details for sediment controls, erosion controls, waste management controls, and non-storm water discharge controls are contained within Appendix XI Construction BMPs of the Project SWPPP.
 5. Preserve existing vegetation within all designated construction areas in accordance with BMP 4-01.
 6. Track-out shall be removed at the end of every business day and as frequently as necessary to keep adjacent roads clean and free of sediment.
 7. Dust control shall be implemented as necessary during construction in accordance with dust (wind erosion) control Bmp 4-08.
 8. All trash containers are required to be covered at all times.
 9. Additional SWPPP BMPs shall be implemented as dictated by site conditions and as recommended by the QSP to prevent erosion and pollutant transport.
 10. Erosion and sediment control BMP implementation at sites accessed by helicopter will be determined in the field by the QSP.



**Site Map
TL682
Map 43 of 49**

**Cleveland National Forest
Power Line Replacement Projects**

LUP TYPE I PROJECT

-  Fiber Roll (BMP 1-03)
-  Contour, 20-ft Interval
-  Wood-to-Steel Replacement
-  Wood-to-Steel Replacement
-  Temp Pole Work Area
-  Navigation Access Road

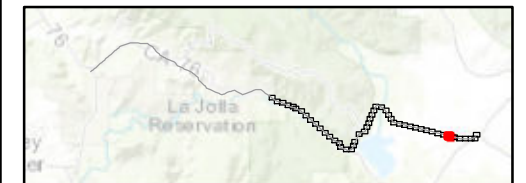

SWPPP Notes:



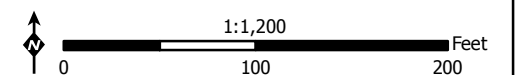



1. Locations of SWPPP BMPs are not to scale.
2. SWPPP BMP locations are conceptual in nature and must be field-verified prior to construction.
3. Erosion and sediment controls shall be deployed prior to pavement or soil disturbance (where applicable) and as recommended by the QSP.
4. SDG&E BMP Details for sediment controls, erosion controls, waste management controls, and non-storm water discharge controls are contained within Appendix XI Construction BMPs of the Project SWPPP.
5. Preserve existing vegetation within all designated construction areas in accordance with BMP 4-01.
6. Track-out shall be removed at the end of every business day and as frequently as necessary to keep adjacent roads clean and free of sediment.
7. Dust control shall be implemented as necessary during construction in accordance with dust (wind erosion) control Bmp 4-08.
8. All trash containers are required to be covered at all times.
9. Additional SWPPP BMPs shall be implemented as dictated by site conditions and as recommended by the QSP to prevent erosion and pollutant transport.
10. Erosion and sediment control BMP implementation at sites accessed by helicopter will be determined in the field by the QSP.



**Site Map
TL682
Map 44 of 49**

**Cleveland National Forest
Power Line Replacement Projects**

LUP TYPE I PROJECT

-  Fiber Roll (BMP 1-03)
-  Contour, 20-ft Interval
-  Wood-to-Steel Replacement
-  Wood-to-Steel Replacement
-  Temp Pole Work Area
-  Navigation Access Road

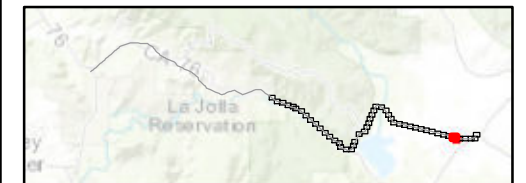
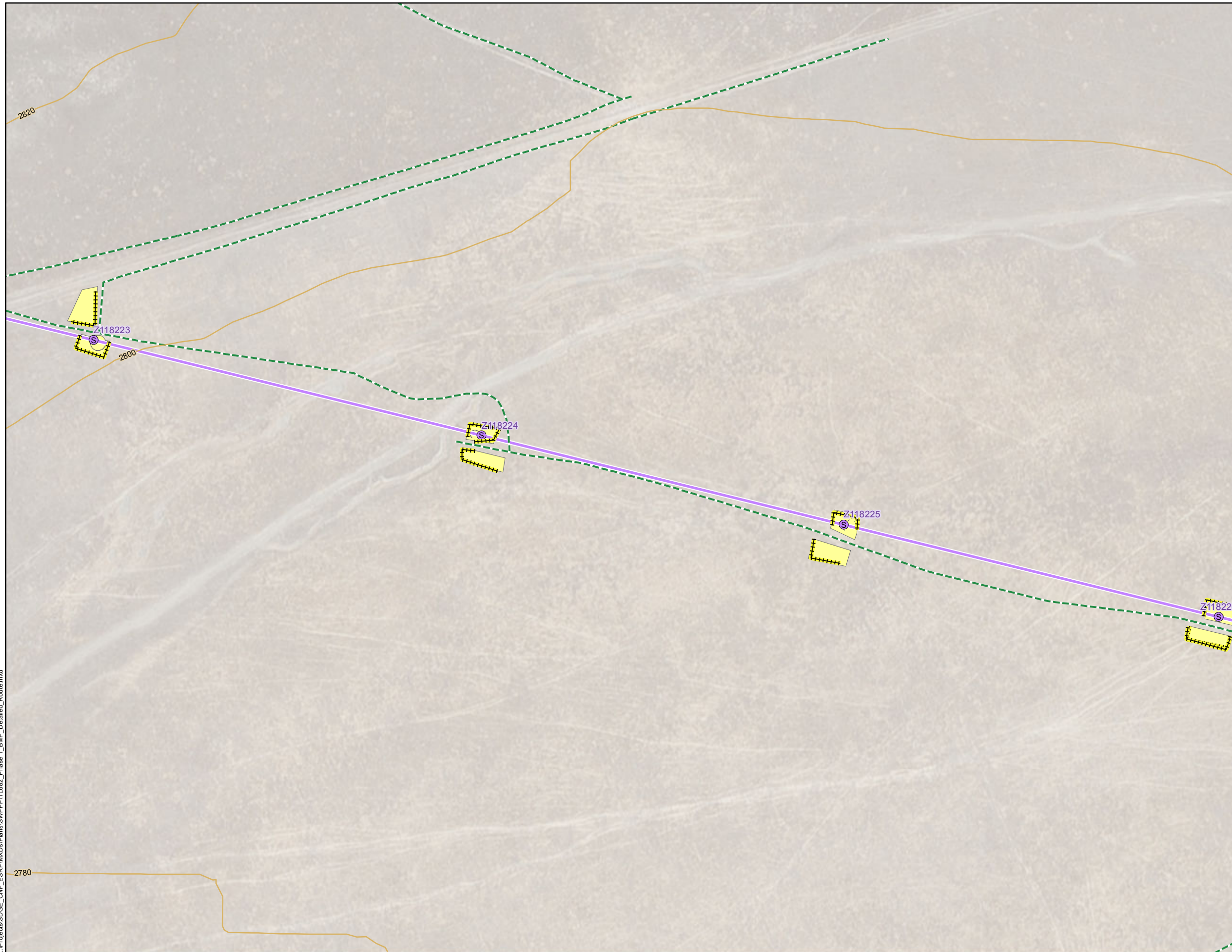



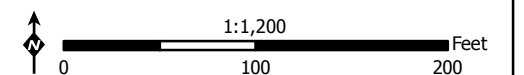







- SWPPP Notes:**
1. Locations of SWPPP BMPs are not to scale.
 2. SWPPP BMP locations are conceptual in nature and must be field-verified prior to construction.
 3. Erosion and sediment controls shall be deployed prior to pavement or soil disturbance (where applicable) and as recommended by the QSP.
 4. SDG&E BMP Details for sediment controls, erosion controls, waste management controls, and non-storm water discharge controls are contained within Appendix XI Construction BMPs of the Project SWPPP.
 5. Preserve existing vegetation within all designated construction areas in accordance with BMP 4-01.
 6. Track-out shall be removed at the end of every business day and as frequently as necessary to keep adjacent roads clean and free of sediment.
 7. Dust control shall be implemented as necessary during construction in accordance with dust (wind erosion) control Bmp 4-08.
 8. All trash containers are required to be covered at all times.
 9. Additional SWPPP BMPs shall be implemented as dictated by site conditions and as recommended by the QSP to prevent erosion and pollutant transport.
 10. Erosion and sediment control BMP implementation at sites accessed by helicopter will be determined in the field by the QSP.



**Site Map
TL682
Map 45 of 49**

**Cleveland National Forest
Power Line Replacement Projects**

LUP TYPE I PROJECT

-  Fiber Roll (BMP 1-03)
-  Silt Fence (BMP 1-02)
-  Stream and Flow Direction
-  Contour, 20-ft Interval
-  Wood-to-Steel Replacement
-  Wood-to-Steel Replacement
-  Anchor Work Area
-  Temp Pole Work Area
-  RFS Anchor
-  Footpath
-  Navigation Access Road

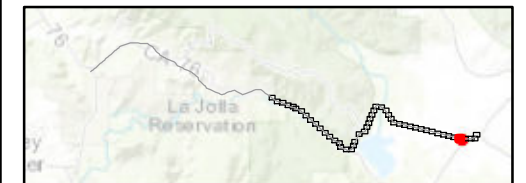

- SWPPP Notes:**
1. Locations of SWPPP BMPs are not to scale.
 2. SWPPP BMP locations are conceptual in nature and must be field-verified prior to construction.
 3. Erosion and sediment controls shall be deployed prior to pavement or soil disturbance (where applicable) and as recommended by the QSP.
 4. SDG&E BMP Details for sediment controls, erosion controls, waste management controls, and non-storm water discharge controls are contained within Appendix XI Construction BMPs of the Project SWPPP.
 5. Preserve existing vegetation within all designated construction areas in accordance with BMP 4-01.
 6. Track-out shall be removed at the end of every business day and as frequently as necessary to keep adjacent roads clean and free of sediment.
 7. Dust control shall be implemented as necessary during construction in accordance with dust (wind erosion) control Bmp 4-08.
 8. All trash containers are required to be covered at all times.
 9. Additional SWPPP BMPs shall be implemented as dictated by site conditions and as recommended by the QSP to prevent erosion and pollutant transport.
 10. Erosion and sediment control BMP implementation at sites accessed by helicopter will be determined in the field by the QSP.

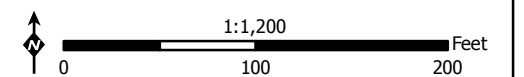











Z:\Projects\SDGE_CNF_ESRP\MXData\Plans\SWPPP\TL682_Phase I_BMP_Detailed_Route.mxd

**Site Map
TL682
Map 46 of 49**

**Cleveland National Forest
Power Line Replacement Projects**

LUP TYPE I PROJECT

-  Fiber Roll (BMP 1-03)
-  Silt Fence (BMP 1-02)
-  Stream and Flow Direction
-  Contour, 20-ft Interval
-  Wood-to-Steel Replacement
-  Wood-to-Steel Replacement
-  Anchor Work Area
-  Temp Pole Work Area
-  RFS Anchor
-  Footpath
-  Navigation Access Road

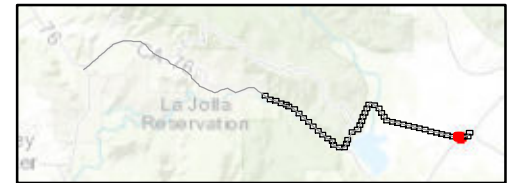
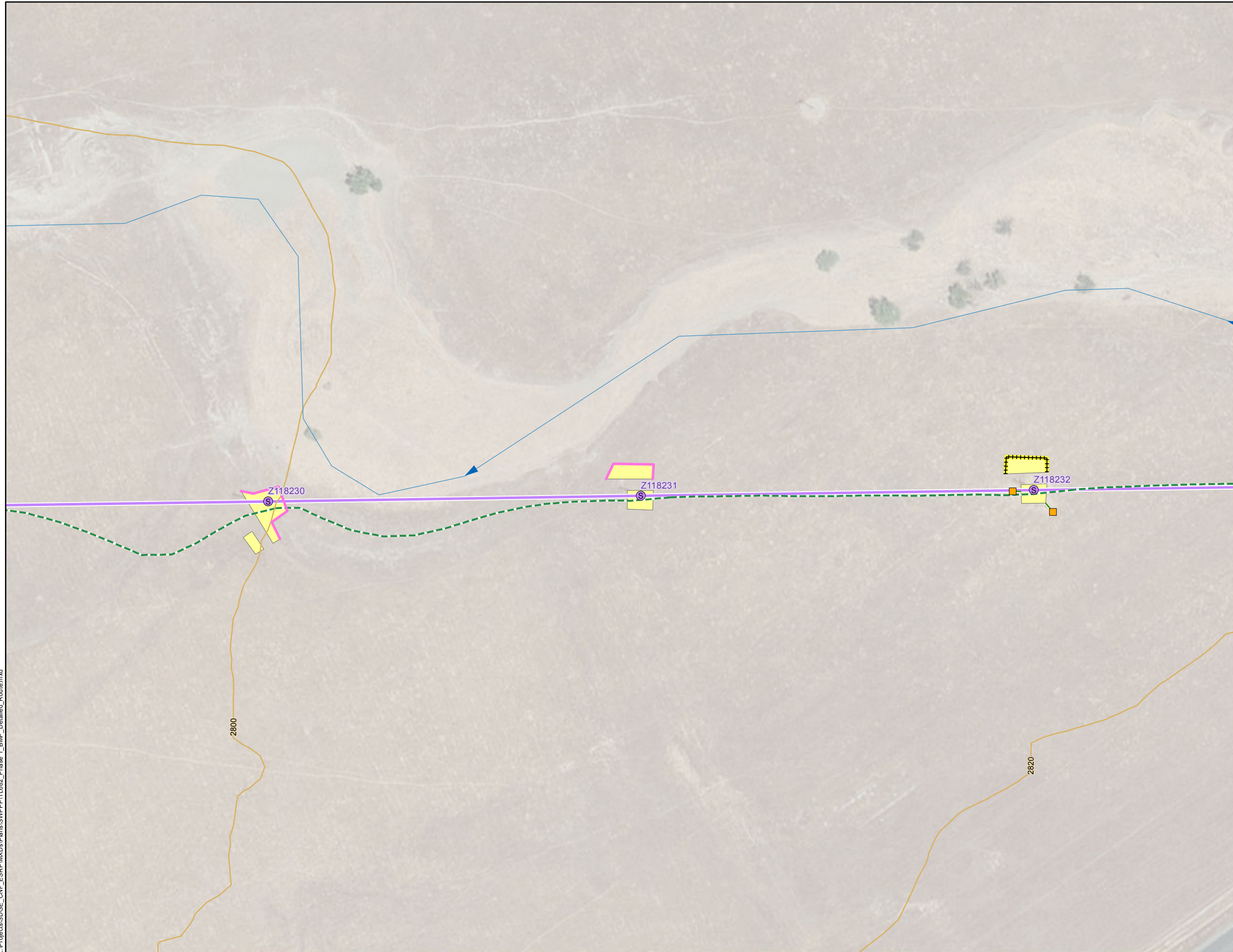



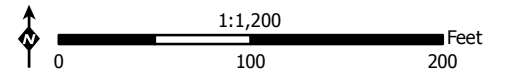









- SWPPP Notes:**
1. Locations of SWPPP BMPs are not to scale.
 2. SWPPP BMP locations are conceptual in nature and must be field-verified prior to construction.
 3. Erosion and sediment controls shall be deployed prior to pavement or soil disturbance (where applicable) and as recommended by the QSP.
 4. SDG&E BMP Details for sediment controls, erosion controls, waste management controls, and non-storm water discharge controls are contained within Appendix XI Construction BMPs of the Project SWPPP.
 5. Preserve existing vegetation within all designated construction areas in accordance with BMP 4-01.
 6. Track-out shall be removed at the end of every business day and as frequently as necessary to keep adjacent roads clean and free of sediment.
 7. Dust control shall be implemented as necessary during construction in accordance with dust (wind erosion) control Bmp 4-08.
 8. All trash containers are required to be covered at all times.
 9. Additional SWPPP BMPs shall be implemented as dictated by site conditions and as recommended by the QSP to prevent erosion and pollutant transport.
 10. Erosion and sediment control BMP implementation at sites accessed by helicopter will be determined in the field by the QSP.



**Site Map
TL682
Map 47 of 49**

**Cleveland National Forest
Power Line Replacement Projects**

LUP TYPE I PROJECT

-  Silt Fence (BMP 1-02)
-  Stream and Flow Direction
-  Contour, 20-ft Interval
-  Wood-to-Steel Replacement
-  Wood-to-Steel Replacement
-  Anchor Work Area
-  Stringing Site
-  Temp Pole Work Area
-  RFS Anchor
-  Construction Access Only
-  Footpath
-  Navigation Access Road

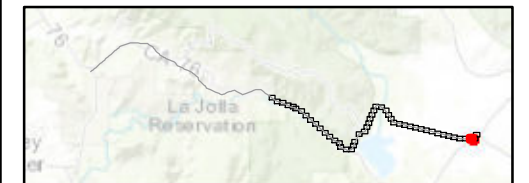

- SWPPP Notes:**
1. Locations of SWPPP BMPs are not to scale.
 2. SWPPP BMP locations are conceptual in nature and must be field-verified prior to construction.
 3. Erosion and sediment controls shall be deployed prior to pavement or soil disturbance (where applicable) and as recommended by the QSP.
 4. SDG&E BMP Details for sediment controls, erosion controls, waste management controls, and non-storm water discharge controls are contained within Appendix XI Construction BMPs of the Project SWPPP.
 5. Preserve existing vegetation within all designated construction areas in accordance with BMP 4-01.
 6. Track-out shall be removed at the end of every business day and as frequently as necessary to keep adjacent roads clean and free of sediment.
 7. Dust control shall be implemented as necessary during construction in accordance with dust (wind erosion) control Bmp 4-08.
 8. All trash containers are required to be covered at all times.
 9. Additional SWPPP BMPs shall be implemented as dictated by site conditions and as recommended by the QSP to prevent erosion and pollutant transport.
 10. Erosion and sediment control BMP implementation at sites accessed by helicopter will be determined in the field by the QSP.

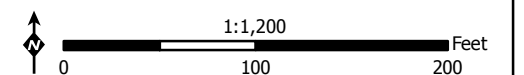















Z:\Projects\SDGE_CNF_ESRP\MXData\Plans\SWPPP\TL682_Phase 1_BMP_Detailed_Route.mxd

**Site Map
TL682
Map 48 of 49**

**Cleveland National Forest
Power Line Replacement Projects**

LUP TYPE I PROJECT

-  Fiber Roll (BMP 1-03)
-  Silt Fence (BMP 1-02)
-  Stream and Flow Direction
-  Contour, 20-ft Interval
-  Wood-to-Steel Replacement
-  Wood-to-Steel Replacement
-  Anchor Work Area
-  Fly Yard/Staging Area
-  Stringing Site
-  Temp Pole Work Area
-  RFS Anchor
-  Construction Access Only
-  Footpath
-  Navigation Access Road

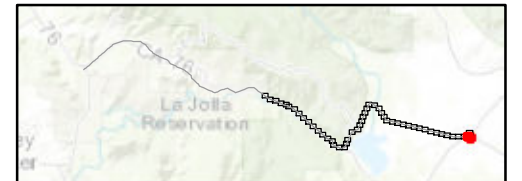

- SWPPP Notes:**
1. Locations of SWPPP BMPs are not to scale.
 2. SWPPP BMP locations are conceptual in nature and must be field-verified prior to construction.
 3. Erosion and sediment controls shall be deployed prior to pavement or soil disturbance (where applicable) and as recommended by the QSP.
 4. SDG&E BMP Details for sediment controls, erosion controls, waste management controls, and non-storm water discharge controls are contained within Appendix XI Construction BMPs of the Project SWPPP.
 5. Preserve existing vegetation within all designated construction areas in accordance with BMP 4-01.
 6. Track-out shall be removed at the end of every business day and as frequently as necessary to keep adjacent roads clean and free of sediment.
 7. Dust control shall be implemented as necessary during construction in accordance with dust (wind erosion) control Bmp 4-08.
 8. All trash containers are required to be covered at all times.
 9. Additional SWPPP BMPs shall be implemented as dictated by site conditions and as recommended by the QSP to prevent erosion and pollutant transport.
 10. Erosion and sediment control BMP implementation at sites accessed by helicopter will be determined in the field by the QSP.

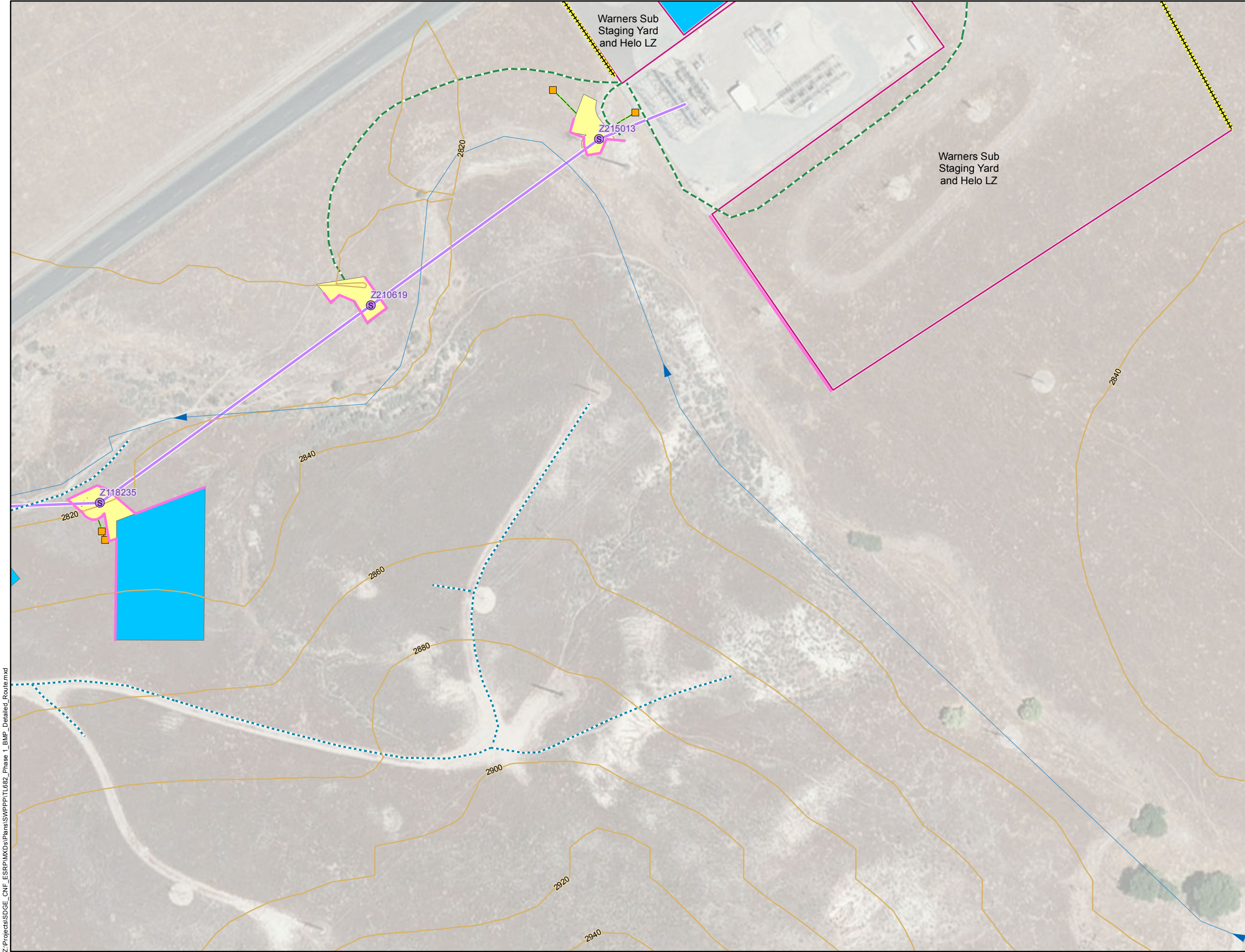
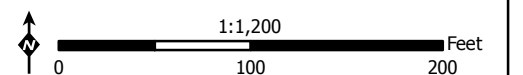



















Z:\Projects\SDGE_CNF_ESR\IWX\Plans\SWPPP\TL682_Phase 1_BMP_Detailed_Route.mxd

**Site Map
TL682
Map 49 of 49**

**Cleveland National Forest
Power Line Replacement Projects**

LUP TYPE I PROJECT

-  Fiber Roll (BMP 1-03)
-  Silt Fence (BMP 1-02)
-  Material Delivery and Storage (BMP 2-01)
-  Sanitary/Septic Waste Management (BMP 2-07)
-  Secondary Containment Required (BMP 2-03)
-  Tracking Controls (BMP-1-07)
-  Vehicle and Equipment Fueling
-  Stream and Flow Direction
-  Contour, 20-ft Interval
-  Wood-to-Steel Replacement
-  Wood-to-Steel Replacement
-  Anchor Work Area
-  Fly Yard/Staging Area
-  Stringing Site
-  Temp Pole Work Area
-  RFS Anchor
-  Footpath
-  Navigation Access Road

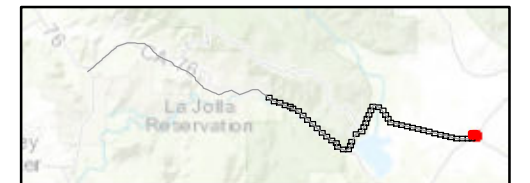

- SWPPP Notes:**
1. Locations of SWPPP BMPs are not to scale.
 2. SWPPP BMP locations are conceptual in nature and must be field-verified prior to construction.
 3. Erosion and sediment controls shall be deployed prior to pavement or soil disturbance (where applicable) and as recommended by the QSP.
 4. SDG&E BMP Details for sediment controls, erosion controls, waste management controls, and non-storm water discharge controls are contained within Appendix XI Construction BMPs of the Project SWPPP.
 5. Preserve existing vegetation within all designated construction areas in accordance with BMP 4-01.
 6. Track-out shall be removed at the end of every business day and as frequently as necessary to keep adjacent roads clean and free of sediment.
 7. Dust control shall be implemented as necessary during construction in accordance with dust (wind erosion) control Bmp 4-08.
 8. All trash containers are required to be covered at all times.
 9. Additional SWPPP BMPs shall be implemented as dictated by site conditions and as recommended by the QSP to prevent erosion and pollutant transport.
 10. Erosion and sediment control BMP implementation at sites accessed by helicopter will be determined in the field by the QSP.

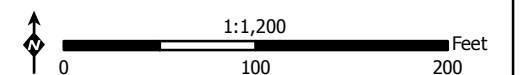

Z:\Projects\SDGE_CNF_ESR\WXData\Plans\SWPPP\TL682_Phase 1_BMP_Detailed_Route.mxd











Warners Sub
Staging Yard
and Helo LZ

Z215013

**TL682
Orchard Staging Yard
Site Map**

**Cleveland National Forest
Power Line Replacement Projects**

LUP TYPE I PROJECT

-  Fiber Roll (BMP 1-03)
-  Material Delivery and Storage (BMP 2-01)
-  Sanitary/Septic Waste Management (BMP 2-07)
-  Secondary Containment Required (BMP 2-03)
-  Stockpile Management (BMP 1-08)
-  Tracking Controls (BMP 1-07)
-  Vehicle and Equipment Fueling
-  Stream and Flow Direction
-  Staging Area
-  Temp Access/Entry/Turnaround



- SWPPP Notes:
1. Locations of SWPPP BMPs are not to scale.
 2. SWPPP BMP locations are conceptual in nature and must be field-verified prior to construction.
 3. Erosion and sediment controls shall be deployed prior to pavement or soil disturbance (where applicable) and as recommended by the QSP.
 4. SDG&E BMP Details for sediment controls, erosion controls, waste management controls, and non-storm water discharge controls are contained within Appendix XI Construction BMPs of the Project SWPPP.
 5. Preserve existing vegetation within all designated construction areas in accordance with BMP 4-01.
 6. Track-out shall be removed at the end of every business day and as frequently as necessary to keep adjacent roads clean and free of sediment.
 7. Dust control shall be implemented as necessary during construction in accordance with dust (wind erosion) control Bmp 4-08.
 8. All trash containers are required to be covered at all times.
 9. Additional SWPPP BMPs shall be implemented as dictated by site conditions and as recommended by the QSP to prevent erosion and pollutant transport.
 10. Erosion and sediment control BMP implementation at sites accessed by helicopter will be determined in the field by the QSP.

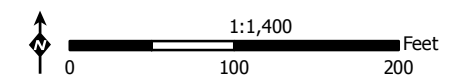











Z:\Projects\SDGE_CNF_ESRP\MXData\Plans\SWPPP\TL682_Orchard_and_Nursery_BMP_Detailed_Route.mxd

**TL682
Nursery Staging Yard
Site Map**

**Cleveland National Forest
Power Line Replacement Projects**

LUP TYPE I PROJECT

-  Fiber Roll (BMP 1-03)
-  Silt Fence (BMP 1-02)
-  Material Delivery and Storage (BMP 2-01)
-  Sanitary/Septic Waste Management (BMP 2-07)
-  Secondary Containment Required (BMP 2-03)
-  Stockpile Management (BMP 1-08)
-  Tracking Controls (BMP 1-07)
-  Stream and Flow Direction
-  Contour, 20-ft Interval
-  Wood-to-Steel Replacement
-  Fly Yard/Staging Area

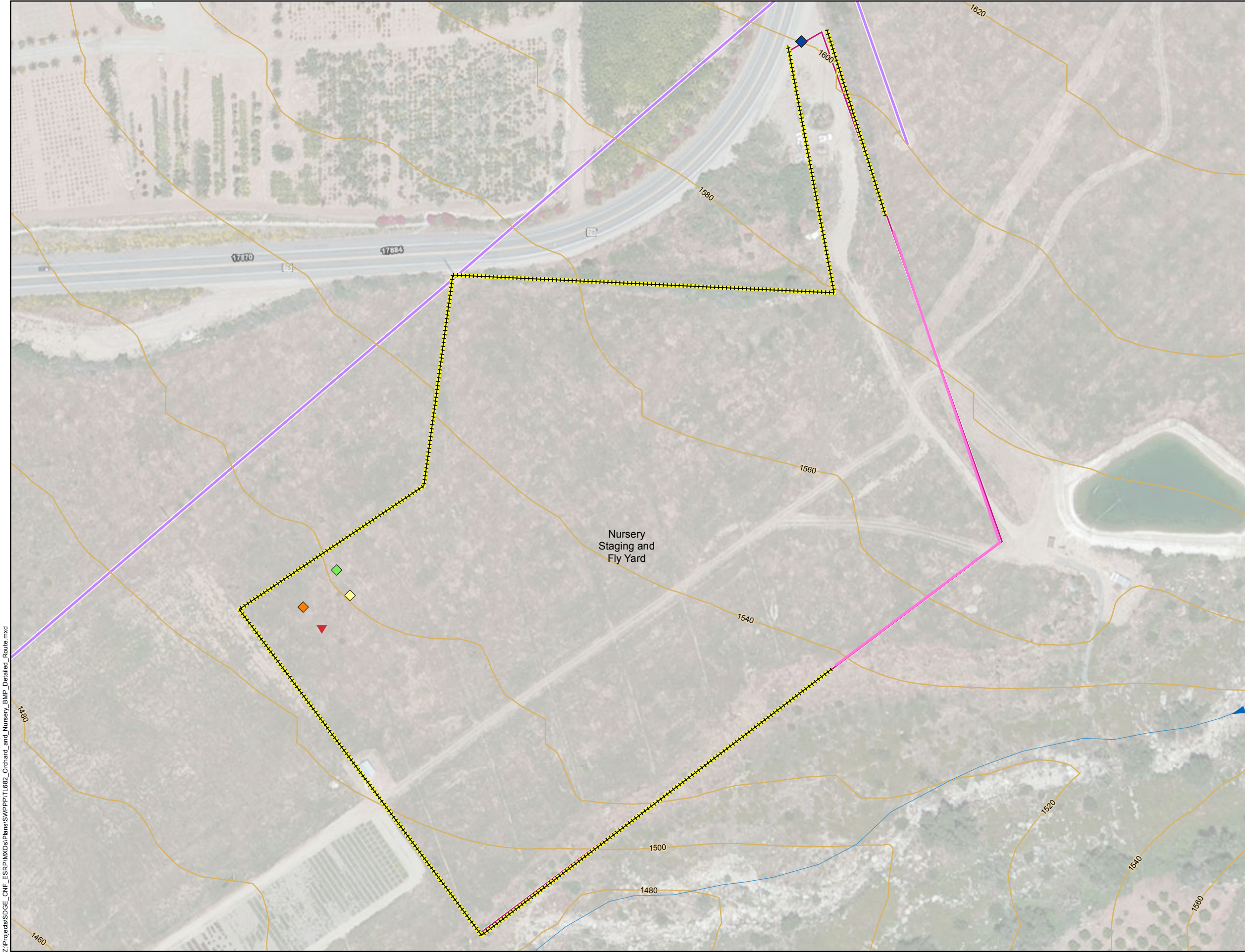

- SWPPP Notes:**
1. Locations of SWPPP BMPs are not to scale.
 2. SWPPP BMP locations are conceptual in nature and must be field-verified prior to construction.
 3. Erosion and sediment controls shall be deployed prior to pavement or soil disturbance (where applicable) and as recommended by the QSP.
 4. SDG&E BMP Details for sediment controls, erosion controls, waste management controls, and non-storm water discharge controls are contained within Appendix XI Construction BMPs of the Project SWPPP.
 5. Preserve existing vegetation within all designated construction areas in accordance with BMP 4-01.
 6. Track-out shall be removed at the end of every business day and as frequently as necessary to keep adjacent roads clean and free of sediment.
 7. Dust control shall be implemented as necessary during construction in accordance with dust (wind erosion) control Bmp 4-08.
 8. All trash containers are required to be covered at all times.
 9. Additional SWPPP BMPs shall be implemented as dictated by site conditions and as recommended by the QSP to prevent erosion and pollutant transport.
 10. Erosion and sediment control BMP implementation at sites accessed by helicopter will be determined in the field by the QSP.

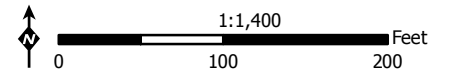







Z:\Projects\SDGE_CNF_ESR\MXData\Plans\SWPPP\TL682_Orchard_and_Nursery_BMP_Detailed_Route.mxd











ATTACHMENT D-3: TL6931 SWPPP BMP SITE MAP

Site Map
TL6931 Map 1 of 29

Cleveland National Forest
Power Line Replacement Projects

LUP TYPE I PROJECT

-  Material Delivery and Storage (BMP 2-01)
-  Stockpile Management (BMP 1-08)
-  Fiber Roll (BMP 1-03)
-  Gravel Bag Berm (BMP 1-04)
-  Track-Out Control (BMP 1-07)
-  Contour, 20-ft Interval

-  Removal
-  Wood-to-Steel Replacement
-  Undergrounding
-  Wood-to-Steel Replacement
-  Maintained Access Road
-  Navigation Access Road
-  Footpath
-  Anchor Work Area
-  Temporary Work Area
-  Temporary Work Entry
-  Bureau of Indian Affairs Land



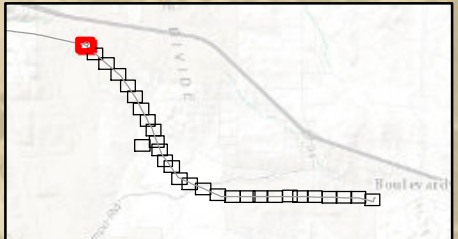
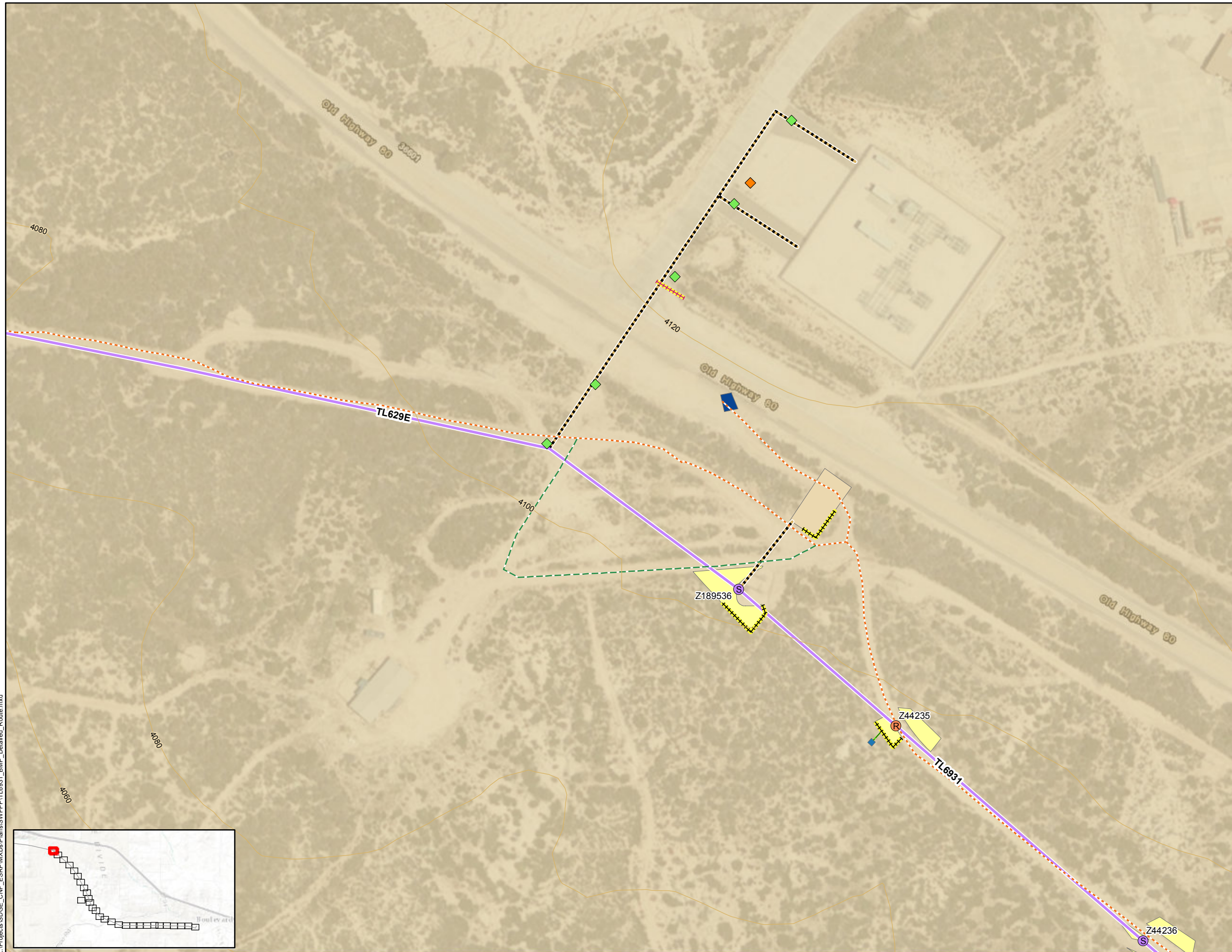
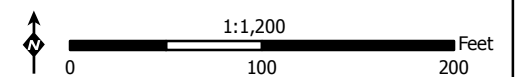













- SWPPP Notes:
1. Locations of SWPPP BMPs are not to scale.
 2. SWPPP BMP locations are conceptual in nature and must be field-verified prior to construction.
 3. Erosion and sediment controls shall be deployed prior to pavement removal or soil disturbance (where applicable) and as recommended by the QSP.
 4. SDG&E BMP Details for sediment controls, erosion controls, waste management controls, and non-storm water discharge controls are contained within Appendix XI Construction BMPs of the Project SWPPP.
 5. Preserve existing vegetation within all designated construction areas in accordance with BMP 4-01.
 6. Track-out shall be removed at the end of every business day and as frequently as necessary to keep adjacent roads clean and free of sediment.
 7. Dust control shall be implemented as necessary during construction in accordance with dust (wind erosion) control BMP 4-08.
 8. All trash containers are required to be covered at all times.
 9. Additional SWPPP BMPs shall be implemented as dictated by site conditions and as recommended by the QSP to prevent erosion and pollutant transport.



Site Map
TL6931 Map 2 of 29

Cleveland National Forest
Power Line Replacement Projects

LUP TYPE I PROJECT

-  Fiber Roll (BMP 1-03)
-  Contour, 20-ft Interval
-  Pole Top Work Only
-  Removal
-  Replace Tap Pole
-  Wood-to-Steel Replacement
-  Wood-to-Steel Replacement
-  Construction Only Access Road
-  Maintained Access Road
-  Navigation Access Road
-  Footpath
-  Anchor Work Area
-  Stringing Site
-  Temporary Work Area
-  Temporary Work Entry
-  Bureau of Indian Affairs Land

- SWPPP Notes:
1. Locations of SWPPP BMPs are not to scale.
 2. SWPPP BMP locations are conceptual in nature and must be field-verified prior to construction.
 3. Erosion and sediment controls shall be deployed prior to pavement removal or soil disturbance (where applicable) and as recommended by the QSP.
 4. SDG&E BMP Details for sediment controls, erosion controls, waste management controls, and non-storm water discharge controls are contained within Appendix XI Construction BMPs of the Project SWPPP.
 5. Preserve existing vegetation within all designated construction areas in accordance with BMP 4-01.
 6. Track-out shall be removed at the end of every business day and as frequently as necessary to keep adjacent roads clean and free of sediment.
 7. Dust control shall be implemented as necessary during construction in accordance with dust (wind erosion) control BMP 4-08.
 8. All trash containers are required to be covered at all times.
 9. Additional SWPPP BMPs shall be implemented as dictated by site conditions and as recommended by the QSP to prevent erosion and pollutant transport.

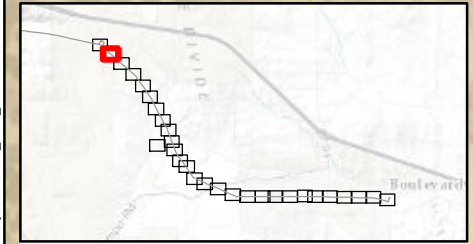
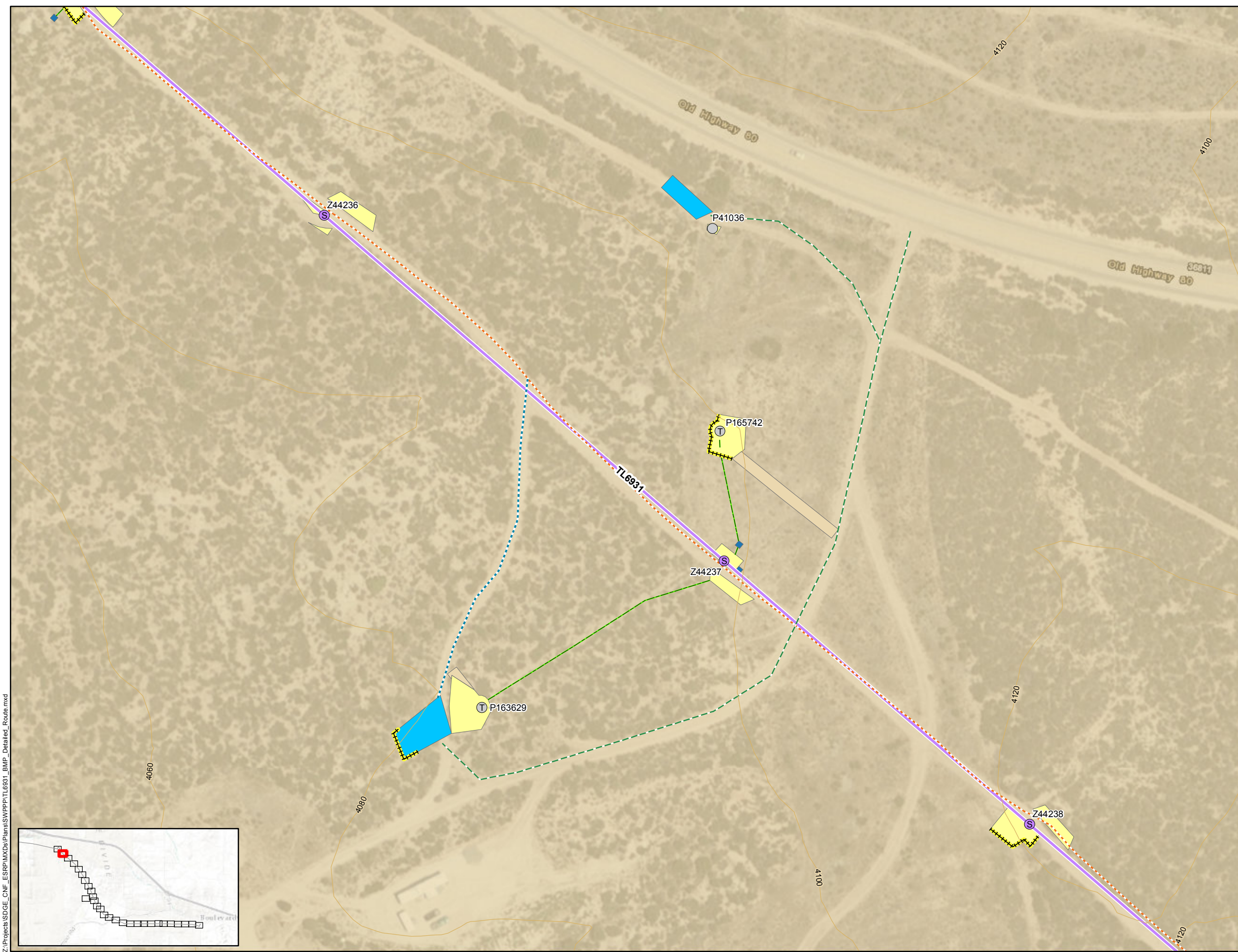
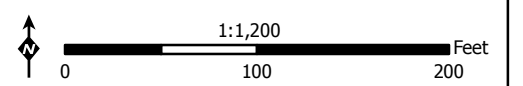





Z:\Projects\SDGE_CNF_ESR\IMX\Plans\SWPPP\TL6931_BMP_Detailed_Route.mxd

Site Map
TL6931 Map 3 of 29

Cleveland National Forest
Power Line Replacement Projects

LUP TYPE I PROJECT

-  Fiber Roll (BMP 1-03)
-  Contour, 20-ft Interval
-  Wood-to-Steel Replacement
-  Wood-to-Steel Replacement
-  Maintained Access Road
-  Temporary Work Area
-  Bureau of Indian Affairs Land

SWPPP Notes:



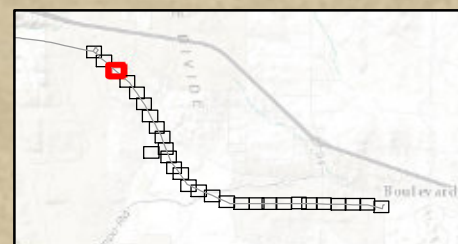
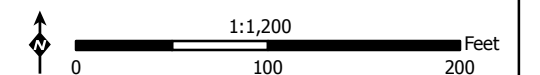





1. Locations of SWPPP BMPs are not to scale.
2. SWPPP BMP locations are conceptual in nature and must be field-verified prior to construction.
3. Erosion and sediment controls shall be deployed prior to pavement removal or soil disturbance (where applicable) and as recommended by the QSP.
4. SDG&E BMP Details for sediment controls, erosion controls, waste management controls, and non-storm water discharge controls are contained within Appendix XI Construction BMPs of the Project SWPPP.
5. Preserve existing vegetation within all designated construction areas in accordance with BMP 4-01.
6. Track-out shall be removed at the end of every business day and as frequently as necessary to keep adjacent roads clean and free of sediment.
7. Dust control shall be implemented as necessary during construction in accordance with dust (wind erosion) control BMP 4-08.
8. All trash containers are required to be covered at all times.
9. Additional SWPPP BMPs shall be implemented as dictated by site conditions and as recommended by the QSP to prevent erosion and pollutant transport.



Site Map
TL6931 Map 4 of 29

Cleveland National Forest
Power Line Replacement Projects

LUP TYPE I PROJECT

-  Contour, 20-ft Interval
-  Wood-to-Steel Replacement
-  Wood-to-Steel Replacement
-  Maintained Access Road
-  Footpath
-  Anchor Work Area
-  Temporary Work Area
-  Bureau of Indian Affairs Land





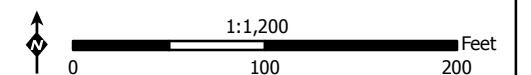
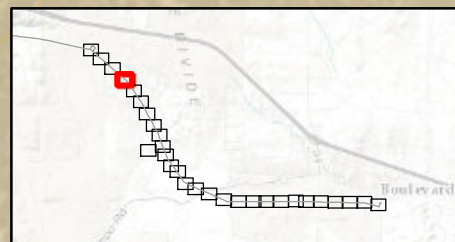





- SWPPP Notes:
1. Locations of SWPPP BMPs are not to scale.
 2. SWPPP BMP locations are conceptual in nature and must be field-verified prior to construction.
 3. Erosion and sediment controls shall be deployed prior to pavement removal or soil disturbance (where applicable) and as recommended by the QSP.
 4. SDG&E BMP Details for sediment controls, erosion controls, waste management controls, and non-storm water discharge controls are contained within Appendix XI Construction BMPs of the Project SWPPP.
 5. Preserve existing vegetation within all designated construction areas in accordance with BMP 4-01.
 6. Track-out shall be removed at the end of every business day and as frequently as necessary to keep adjacent roads clean and free of sediment.
 7. Dust control shall be implemented as necessary during construction in accordance with dust (wind erosion) control BMP 4-08.
 8. All trash containers are required to be covered at all times.
 9. Additional SWPPP BMPs shall be implemented as dictated by site conditions and as recommended by the QSP to prevent erosion and pollutant transport.



Site Map
TL6931 Map 5 of 29

Cleveland National Forest
Power Line Replacement Projects

LUP TYPE I PROJECT

-  Fiber Roll (BMP 1-03)
-  Contour, 20-ft Interval
-  Wood-to-Steel Replacement
-  Wood-to-Steel Replacement
-  Maintained Access Road
-  Navigation Access Road
-  Temporary Work Area
-  Bureau of Indian Affairs Land

SWPPP Notes:



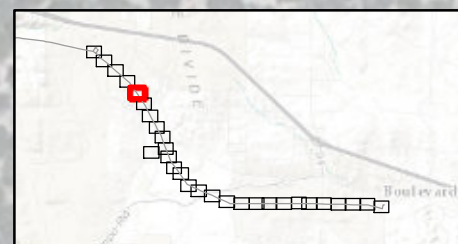
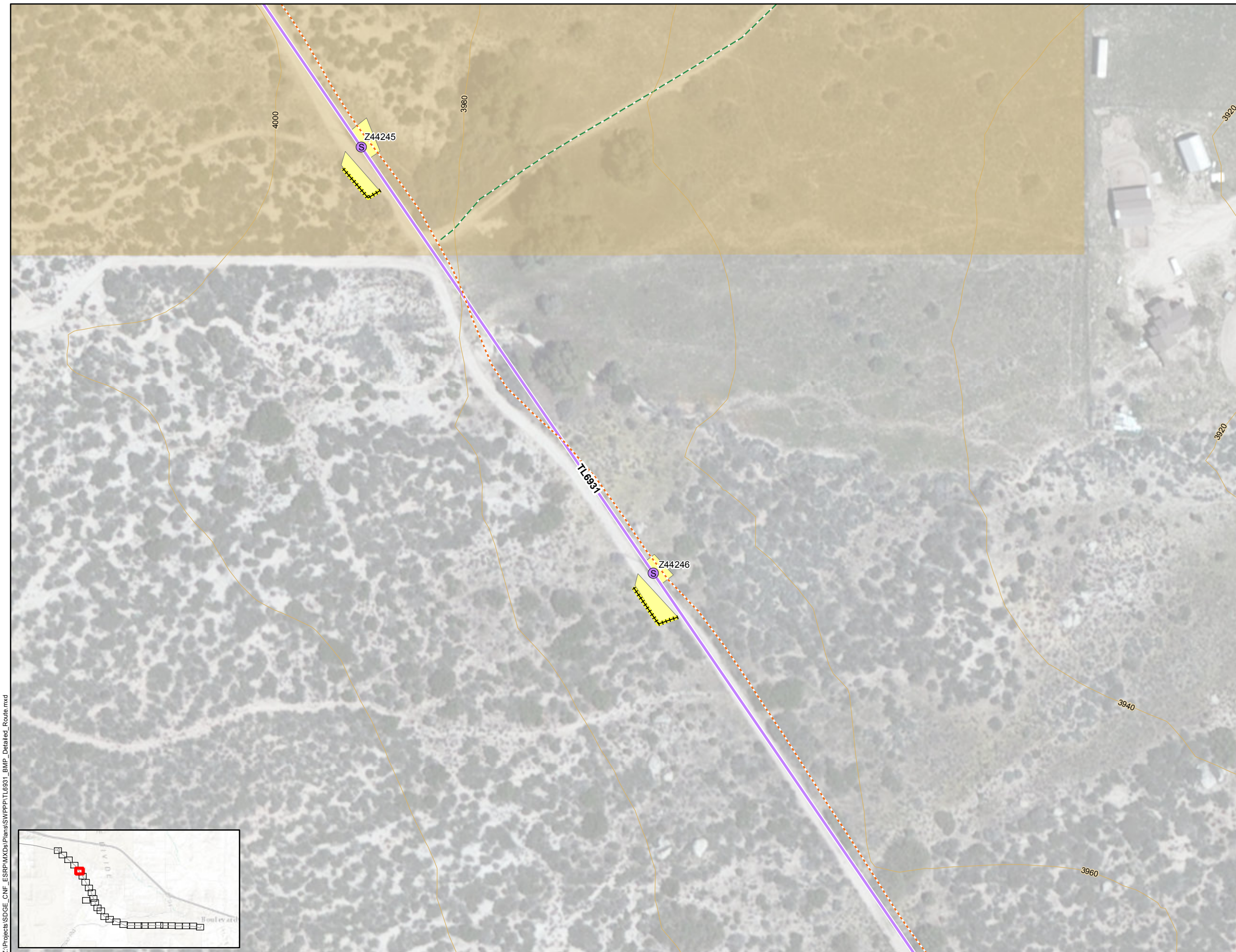
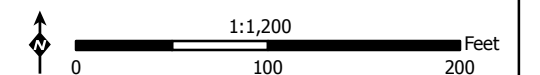



1. Locations of SWPPP BMPs are not to scale.
2. SWPPP BMP locations are conceptual in nature and must be field-verified prior to construction.
3. Erosion and sediment controls shall be deployed prior to pavement removal or soil disturbance (where applicable) and as recommended by the QSP.
4. SDG&E BMP Details for sediment controls, erosion controls, waste management controls, and non-storm water discharge controls are contained within Appendix XI Construction BMPs of the Project SWPPP.
5. Preserve existing vegetation within all designated construction areas in accordance with BMP 4-01.
6. Track-out shall be removed at the end of every business day and as frequently as necessary to keep adjacent roads clean and free of sediment.
7. Dust control shall be implemented as necessary during construction in accordance with dust (wind erosion) control BMP 4-08.
8. All trash containers are required to be covered at all times.
9. Additional SWPPP BMPs shall be implemented as dictated by site conditions and as recommended by the QSP to prevent erosion and pollutant transport.



Site Map
TL6931 Map 6 of 29

Cleveland National Forest
Power Line Replacement Projects

LUP TYPE I PROJECT

-  Contour, 20-ft Interval
-  Wood-to-Steel Replacement
-  Maintained Access Road
-  Footpath
-  Anchor Work Area
-  Temporary Work Area



- SWPPP Notes:**
1. Locations of SWPPP BMPs are not to scale.
 2. SWPPP BMP locations are conceptual in nature and must be field-verified prior to construction.
 3. Erosion and sediment controls shall be deployed prior to pavement removal or soil disturbance (where applicable) and as recommended by the QSP.
 4. SDG&E BMP Details for sediment controls, erosion controls, waste management controls, and non-storm water discharge controls are contained within Appendix XI Construction BMPs of the Project SWPPP.
 5. Preserve existing vegetation within all designated construction areas in accordance with BMP 4-01.
 6. Track-out shall be removed at the end of every business day and as frequently as necessary to keep adjacent roads clean and free of sediment.
 7. Dust control shall be implemented as necessary during construction in accordance with dust (wind erosion) control BMP 4-08.
 8. All trash containers are required to be covered at all times.
 9. Additional SWPPP BMPs shall be implemented as dictated by site conditions and as recommended by the QSP to prevent erosion and pollutant transport.

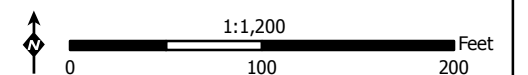









Z:\Projects\SDGE_CNF_ESRPMXD\Plans\SWPPP\TL6931_BMP_Detailed_Route.mxd

Site Map
TL6931 Map 7 of 29

Cleveland National Forest
Power Line Replacement Projects

LUP TYPE I PROJECT

-  Fiber Roll (BMP 1-03)
-  Contour, 20-ft Interval
-  Wood-to-Steel Replacement
-  Wood-to-Steel Replacement
-  Maintained Access Road
-  Footpath
-  Anchor Work Area
-  Guard Structure Work Area
-  Temporary Work Area

- SWPPP Notes:
1. Locations of SWPPP BMPs are not to scale.
 2. SWPPP BMP locations are conceptual in nature and must be field-verified prior to construction.
 3. Erosion and sediment controls shall be deployed prior to pavement removal or soil disturbance (where applicable) and as recommended by the QSP.
 4. SDG&E BMP Details for sediment controls, erosion controls, waste management controls, and non-storm water discharge controls are contained within Appendix XI Construction BMPs of the Project SWPPP.
 5. Preserve existing vegetation within all designated construction areas in accordance with BMP 4-01.
 6. Track-out shall be removed at the end of every business day and as frequently as necessary to keep adjacent roads clean and free of sediment.
 7. Dust control shall be implemented as necessary during construction in accordance with dust (wind erosion) control BMP 4-08.
 8. All trash containers are required to be covered at all times.
 9. Additional SWPPP BMPs shall be implemented as dictated by site conditions and as recommended by the QSP to prevent erosion and pollutant transport.

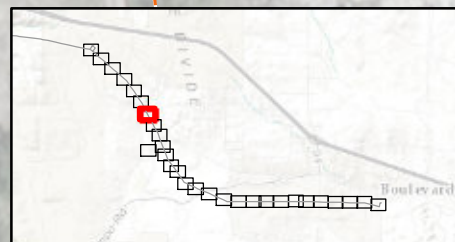
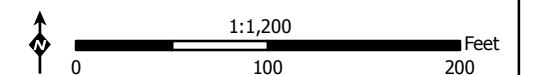







Z:\Projects\SDGE_CNF_ESRPI\MXDs\Plans\SWPPP\TL6931_BMP_Detailed_Route.mxd

Site Map
TL6931 Map 8 of 29

Cleveland National Forest
Power Line Replacement Projects

LUP TYPE I PROJECT

-  Fiber Roll (BMP 1-03)
-  Stream
-  Flow Direction
-  Contour, 20-ft Interval
-  Wood-to-Steel Replacement
-  Wood-to-Steel Replacement
-  Maintained Access Road
-  Stringing Site
-  Temporary Work Area

SWPPP Notes:

1. Locations of SWPPP BMPs are not to scale.
2. SWPPP BMP locations are conceptual in nature and must be field-verified prior to construction.
3. Erosion and sediment controls shall be deployed prior to pavement removal or soil disturbance (where applicable) and as recommended by the QSP.
4. SDG&E BMP Details for sediment controls, erosion controls, waste management controls, and non-storm water discharge controls are contained within Appendix XI Construction BMPs of the Project SWPPP.
5. Preserve existing vegetation within all designated construction areas in accordance with BMP 4-01.
6. Track-out shall be removed at the end of every business day and as frequently as necessary to keep adjacent roads clean and free of sediment.
7. Dust control shall be implemented as necessary during construction in accordance with dust (wind erosion) control BMP 4-08.
8. All trash containers are required to be covered at all times.
9. Additional SWPPP BMPs shall be implemented as dictated by site conditions and as recommended by the QSP to prevent erosion and pollutant transport.

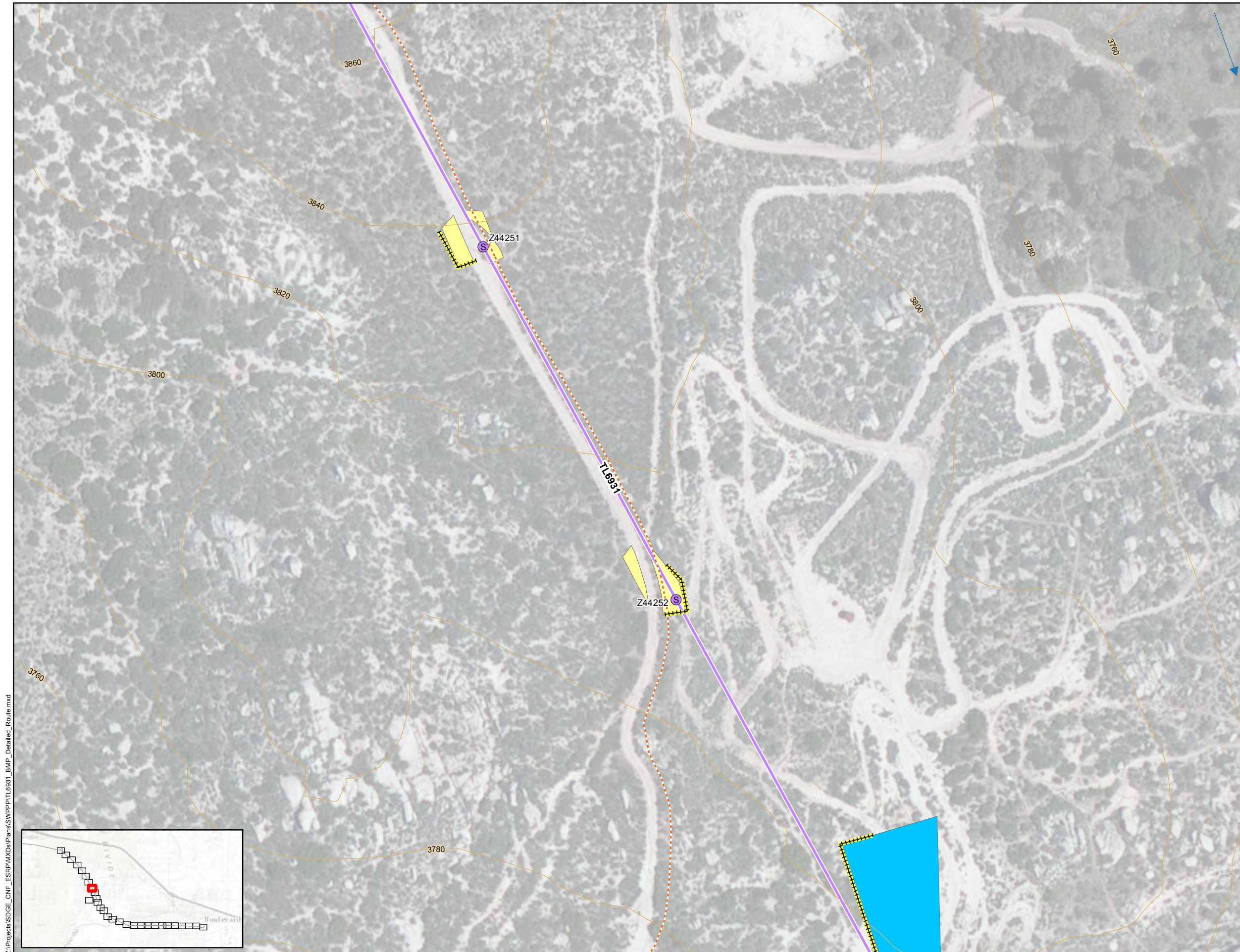
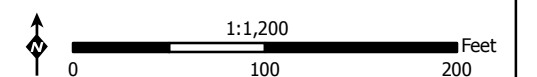











Z:\Projects\SDGE_CNF_ESRPI\MXDs\Plans\SWPPP\TL6931_BMP_Detailed_Route.mxd

Site Map
TL6931 Map 9 of 29

Cleveland National Forest
Power Line Replacement Projects

LUP TYPE I PROJECT

-  Fiber Roll (BMP 1-03)
-  Stream
-  Flow Direction
-  Contour, 20-ft Interval
-  Wood-to-Steel Replacement
-  Wood-to-Steel Replacement
-  Maintained Access Road
-  Anchor Work Area
-  Stringing Site
-  Temporary Work Area

- SWPPP Notes:
1. Locations of SWPPP BMPs are not to scale.
 2. SWPPP BMP locations are conceptual in nature and must be field-verified prior to construction.
 3. Erosion and sediment controls shall be deployed prior to pavement removal or soil disturbance (where applicable) and as recommended by the QSP.
 4. SDG&E BMP Details for sediment controls, erosion controls, waste management controls, and non-storm water discharge controls are contained within Appendix XI Construction BMPs of the Project SWPPP.
 5. Preserve existing vegetation within all designated construction areas in accordance with BMP 4-01.
 6. Track-out shall be removed at the end of every business day and as frequently as necessary to keep adjacent roads clean and free of sediment.
 7. Dust control shall be implemented as necessary during construction in accordance with dust (wind erosion) control BMP 4-08.
 8. All trash containers are required to be covered at all times.
 9. Additional SWPPP BMPs shall be implemented as dictated by site conditions and as recommended by the QSP to prevent erosion and pollutant transport.

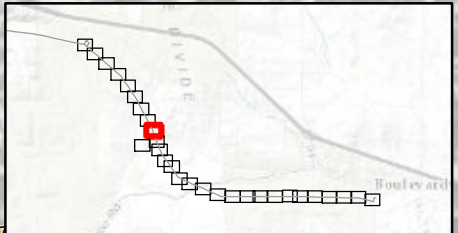
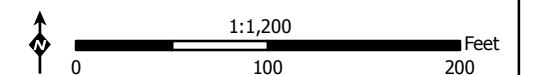









Z:\Projects\SDGE_CNF_ESRPI\MXDs\Plans\SWPPP\TL6931_BMP_Detailed_Route.mxd

Site Map
TL6931 Map 10 of 29

Cleveland National Forest
Power Line Replacement Projects

LUP TYPE I PROJECT

-  Sanitary/Septic Waste Management (BMP 2-07)
-  Material Delivery and Storage (BMP 2-01)
-  Secondary Containment Required (BMP 2-03)
-  Silt Fence (BMP 1-02)
-  Track-Out Control (BMP 1-07)
-  Contour, 20-ft Interval
-  Construction Only Access Road
-  Maintained Access Road
-  Staging Area



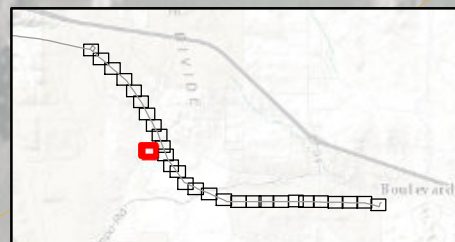
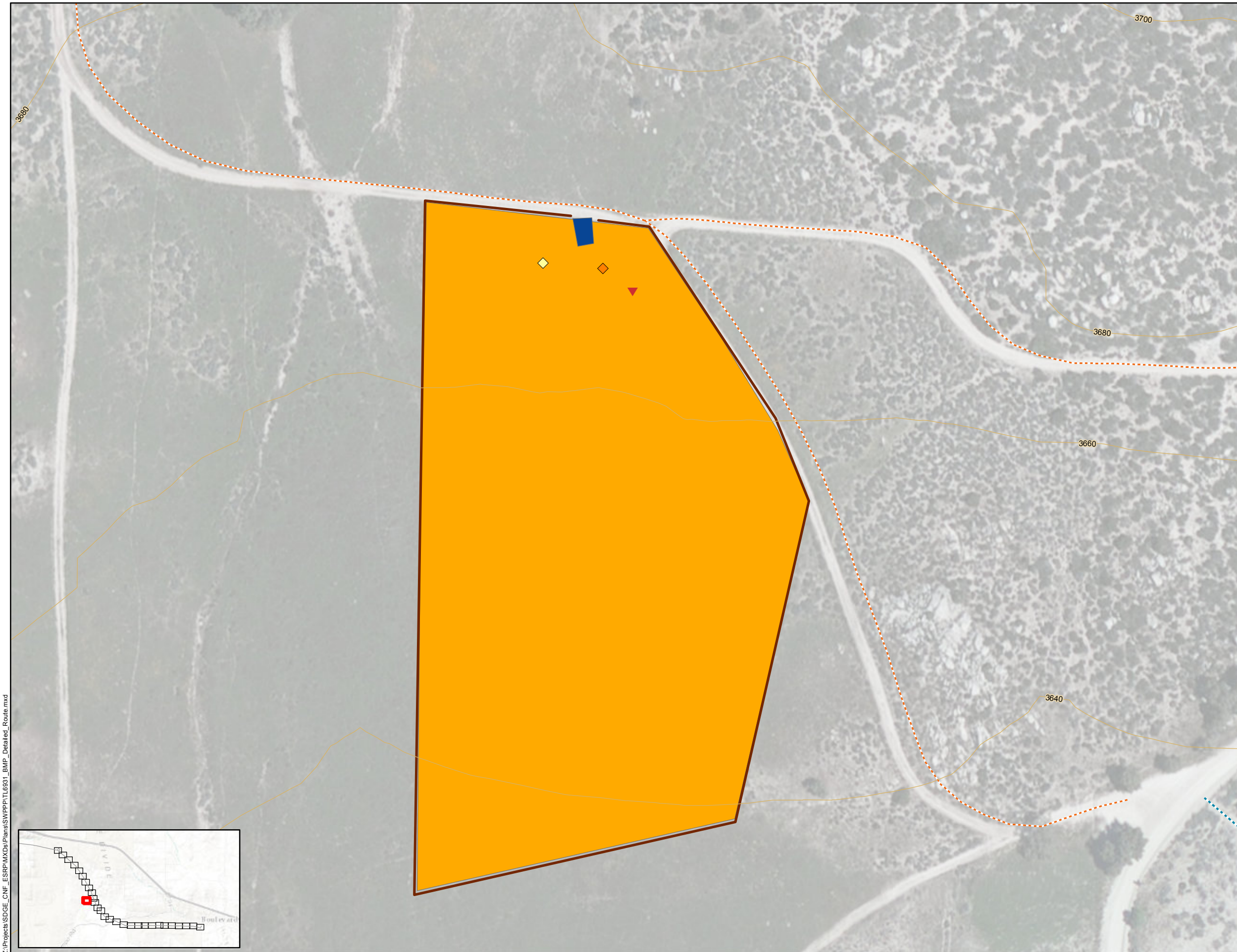
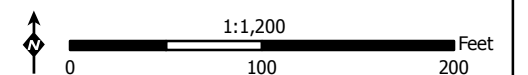







- SWPPP Notes:
1. Locations of SWPPP BMPs are not to scale.
 2. SWPPP BMP locations are conceptual in nature and must be field-verified prior to construction.
 3. Erosion and sediment controls shall be deployed prior to pavement removal or soil disturbance (where applicable) and as recommended by the QSP.
 4. SDG&E BMP Details for sediment controls, erosion controls, waste management controls, and non-storm water discharge controls are contained within Appendix XI Construction BMPs of the Project SWPPP.
 5. Preserve existing vegetation within all designated construction areas in accordance with BMP 4-01.
 6. Track-out shall be removed at the end of every business day and as frequently as necessary to keep adjacent roads clean and free of sediment.
 7. Dust control shall be implemented as necessary during construction in accordance with dust (wind erosion) control BMP 4-08.
 8. All trash containers are required to be covered at all times.
 9. Additional SWPPP BMPs shall be implemented as dictated by site conditions and as recommended by the QSP to prevent erosion and pollutant transport.



Site Map
TL6931 Map 11 of 29

Cleveland National Forest
Power Line Replacement Projects

LUP TYPE | PROJECT

-  Fiber Roll (BMP 1-03)
-  Stream
-  Flow Direction
-  Contour, 20-ft Interval
-  Wood-to-Steel Replacement
-  Wood-to-Steel Replacement
-  Maintained Access Road
-  Footpath
-  Anchor Work Area
-  Guard Structure Work Area
-  Temporary Work Area

- SWPPP Notes:
1. Locations of SWPPP BMPs are not to scale.
 2. SWPPP BMP locations are conceptual in nature and must be field-verified prior to construction.
 3. Erosion and sediment controls shall be deployed prior to pavement removal or soil disturbance (where applicable) and as recommended by the QSP.
 4. SDG&E BMP Details for sediment controls, erosion controls, waste management controls, and non-storm water discharge controls are contained within Appendix XI Construction BMPs of the Project SWPPP.
 5. Preserve existing vegetation within all designated construction areas in accordance with BMP 4-01.
 6. Track-out shall be removed at the end of every business day and as frequently as necessary to keep adjacent roads clean and free of sediment.
 7. Dust control shall be implemented as necessary during construction in accordance with dust (wind erosion) control BMP 4-08.
 8. All trash containers are required to be covered at all times.
 9. Additional SWPPP BMPs shall be implemented as dictated by site conditions and as recommended by the QSP to prevent erosion and pollutant transport.

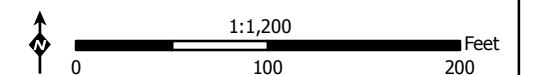











Z:\Projects\SDGE_CNF_ESRPI\MXDs\Plans\SWPPP\TL6931_BMP_Detailed_Route.mxd

Site Map
TL6931 Map 12 of 29

Cleveland National Forest
Power Line Replacement Projects

LUP TYPE I PROJECT

-  Fiber Roll (BMP 1-03)
-  Stream
-  Flow Direction
-  Contour, 20-ft Interval

-  Wood-to-Steel Replacement
-  Wood-to-Steel Replacement
-  Construction Only Access Road
-  Maintained Access Road
-  Footpath
-  Anchor Work Area
-  Temporary Work Area

- SWPPP Notes:
1. Locations of SWPPP BMPs are not to scale.
 2. SWPPP BMP locations are conceptual in nature and must be field-verified prior to construction.
 3. Erosion and sediment controls shall be deployed prior to pavement removal or soil disturbance (where applicable) and as recommended by the QSP.
 4. SDG&E BMP Details for sediment controls, erosion controls, waste management controls, and non-storm water discharge controls are contained within Appendix XI Construction BMPs of the Project SWPPP.
 5. Preserve existing vegetation within all designated construction areas in accordance with BMP 4-01.
 6. Track-out shall be removed at the end of every business day and as frequently as necessary to keep adjacent roads clean and free of sediment.
 7. Dust control shall be implemented as necessary during construction in accordance with dust (wind erosion) control BMP 4-08.
 8. All trash containers are required to be covered at all times.
 9. Additional SWPPP BMPs shall be implemented as dictated by site conditions and as recommended by the QSP to prevent erosion and pollutant transport.

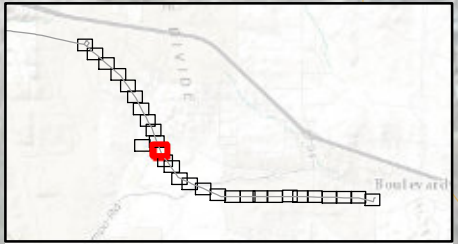
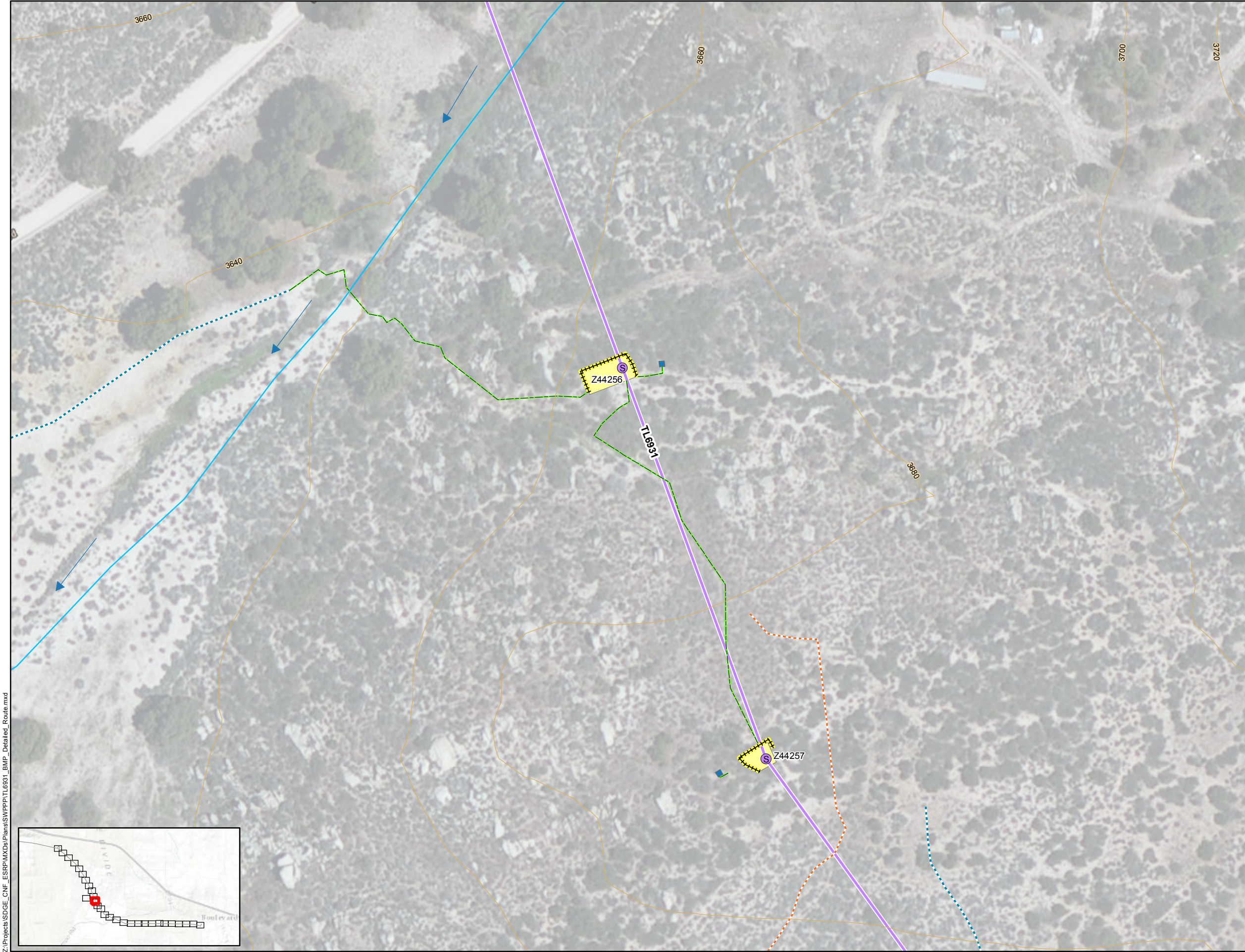
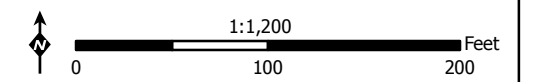













Z:\Projects\SDGE_CNF_ESRP\MXDs\Plans\SWPPP\TL6931_BMP_Detailed_Route.mxd

Site Map
TL6931 Map 13 of 29

Cleveland National Forest
Power Line Replacement Projects

LUP TYPE I PROJECT

-  Fiber Roll (BMP 1-03)
-  Stream
-  Flow Direction
-  Contour, 20-ft Interval

-  Replace Tap Pole
-  Wood-to-Steel Replacement
-  Wood-to-Steel Replacement
-  Construction Only Access Road
-  Maintained Access Road
-  Footpath
-  Stringing Site
-  Temporary Work Area

- SWPPP Notes:
1. Locations of SWPPP BMPs are not to scale.
 2. SWPPP BMP locations are conceptual in nature and must be field-verified prior to construction.
 3. Erosion and sediment controls shall be deployed prior to pavement removal or soil disturbance (where applicable) and as recommended by the QSP.
 4. SDG&E BMP Details for sediment controls, erosion controls, waste management controls, and non-storm water discharge controls are contained within Appendix XI Construction BMPs of the Project SWPPP.
 5. Preserve existing vegetation within all designated construction areas in accordance with BMP 4-01.
 6. Track-out shall be removed at the end of every business day and as frequently as necessary to keep adjacent roads clean and free of sediment.
 7. Dust control shall be implemented as necessary during construction in accordance with dust (wind erosion) control BMP 4-08.
 8. All trash containers are required to be covered at all times.
 9. Additional SWPPP BMPs shall be implemented as dictated by site conditions and as recommended by the QSP to prevent erosion and pollutant transport.

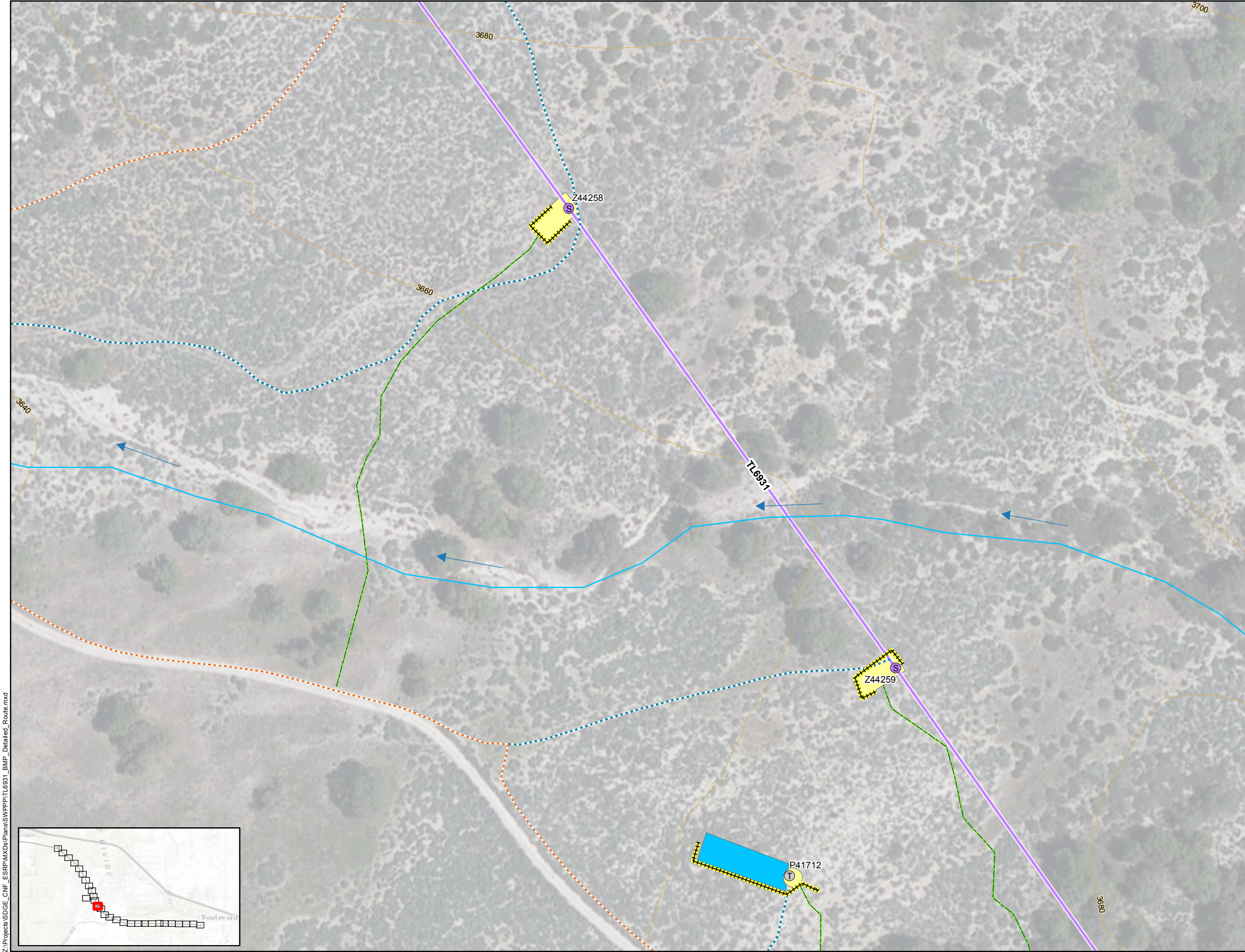
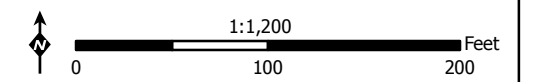













Z:\Projects\SDGE_CNF_ESRPMX\Plans\SWPPP\TL6931_BMP_Detailed_Route.mxd

Site Map
TL6931 Map 14 of 29

Cleveland National Forest
Power Line Replacement Projects

LUP TYPE I PROJECT

-  Fiber Roll (BMP 1-03)
-  Stream
-  Flow Direction
-  Contour, 20-ft Interval

-  Replace Tap Pole
-  Wood-to-Steel Replacement
-  Wood-to-Steel Replacement
-  Construction Only Access Road
-  Maintained Access Road
-  Navigation Access Road
-  Footpath
-  Stringing Site
-  Temporary Work Area

- SWPPP Notes:
1. Locations of SWPPP BMPs are not to scale.
 2. SWPPP BMP locations are conceptual in nature and must be field-verified prior to construction.
 3. Erosion and sediment controls shall be deployed prior to pavement removal or soil disturbance (where applicable) and as recommended by the QSP.
 4. SDG&E BMP Details for sediment controls, erosion controls, waste management controls, and non-storm water discharge controls are contained within Appendix XI Construction BMPs of the Project SWPPP.
 5. Preserve existing vegetation within all designated construction areas in accordance with BMP 4-01.
 6. Track-out shall be removed at the end of every business day and as frequently as necessary to keep adjacent roads clean and free of sediment.
 7. Dust control shall be implemented as necessary during construction in accordance with dust (wind erosion) control BMP 4-08.
 8. All trash containers are required to be covered at all times.
 9. Additional SWPPP BMPs shall be implemented as dictated by site conditions and as recommended by the QSP to prevent erosion and pollutant transport.

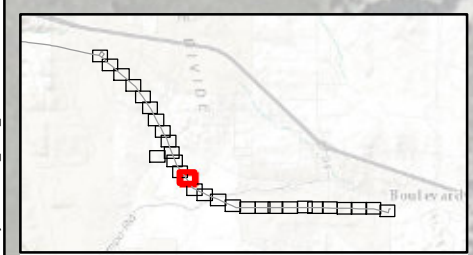
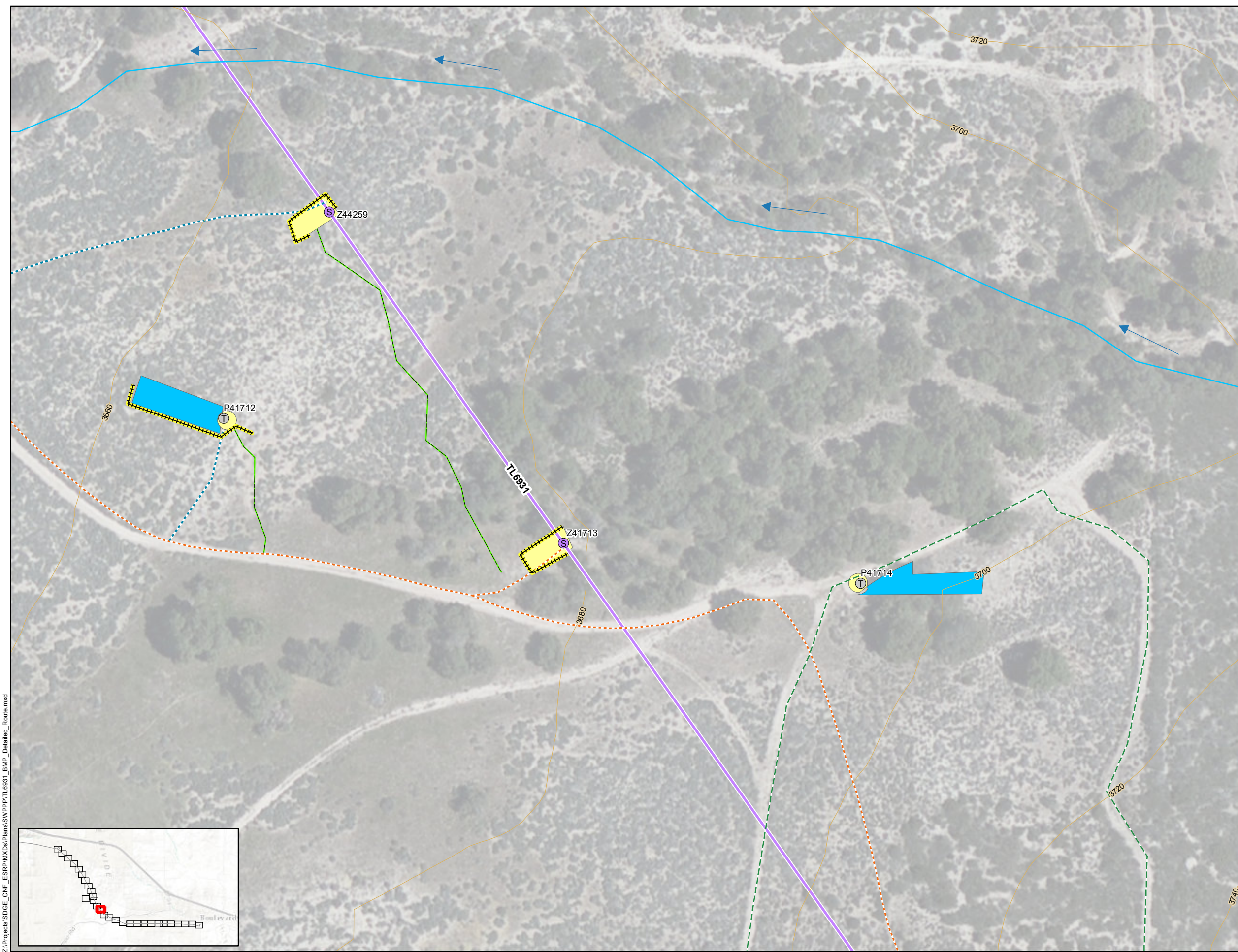
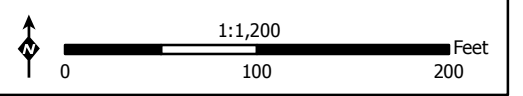















Z:\Projects\SDGE_CNF_ESRPMXD\Plans\SWPPP\TL6931_BMP_Detailed_Route.mxd

Site Map
TL6931 Map 15 of 29

Cleveland National Forest
Power Line Replacement Projects

LUP TYPE I PROJECT

-  Fiber Roll (BMP 1-03)
-  Contour, 20-ft Interval
-  Pole Top Work Only
-  Replace Tap Pole
-  Wood-to-Steel Replacement
-  Wood-to-Steel Replacement 12 kV Only
-  Wood-to-Steel Replacement
-  Maintained Access Road
-  Navigation Access Road
-  Footpath
-  Anchor Work Area
-  Stringing Site
-  Temporary Work Area
-  Temporary Work Entry

- SWPPP Notes:
1. Locations of SWPPP BMPs are not to scale.
 2. SWPPP BMP locations are conceptual in nature and must be field-verified prior to construction.
 3. Erosion and sediment controls shall be deployed prior to pavement removal or soil disturbance (where applicable) and as recommended by the QSP.
 4. SDG&E BMP Details for sediment controls, erosion controls, waste management controls, and non-storm water discharge controls are contained within Appendix XI Construction BMPs of the Project SWPPP.
 5. Preserve existing vegetation within all designated construction areas in accordance with BMP 4-01.
 6. Track-out shall be removed at the end of every business day and as frequently as necessary to keep adjacent roads clean and free of sediment.
 7. Dust control shall be implemented as necessary during construction in accordance with dust (wind erosion) control BMP 4-08.
 8. All trash containers are required to be covered at all times.
 9. Additional SWPPP BMPs shall be implemented as dictated by site conditions and as recommended by the QSP to prevent erosion and pollutant transport.

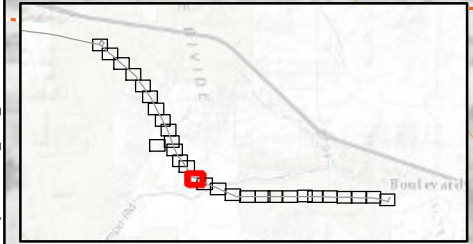
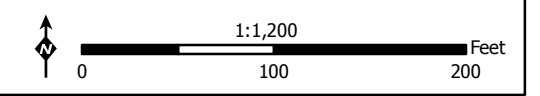















Z:\Projects\SDGE_CNF_ESRPMX\Plans\SWPPP\TL6931_BMP_Detailed_Route.mxd

Site Map
TL6931 Map 16 of 29

Cleveland National Forest
Power Line Replacement Projects

LUP TYPE I PROJECT

-  Fiber Roll (BMP 1-03)
-  Contour, 20-ft Interval
-  Pole Top Work Only
-  Replace Tap Pole
-  Wood-to-Steel Replacement
-  Wood-to-Steel Replacement 12 kV Only
-  Wood-to-Steel Replacement
-  Navigation Access Road
-  Footpath
-  Anchor Work Area
-  Guard Structure Work Area
-  Stringing Site
-  Temporary Work Area
-  Temporary Work Entry

- SWPPP Notes:
1. Locations of SWPPP BMPs are not to scale.
 2. SWPPP BMP locations are conceptual in nature and must be field-verified prior to construction.
 3. Erosion and sediment controls shall be deployed prior to pavement removal or soil disturbance (where applicable) and as recommended by the QSP.
 4. SDG&E BMP Details for sediment controls, erosion controls, waste management controls, and non-storm water discharge controls are contained within Appendix XI Construction BMPs of the Project SWPPP.
 5. Preserve existing vegetation within all designated construction areas in accordance with BMP 4-01.
 6. Track-out shall be removed at the end of every business day and as frequently as necessary to keep adjacent roads clean and free of sediment.
 7. Dust control shall be implemented as necessary during construction in accordance with dust (wind erosion) control BMP 4-08.
 8. All trash containers are required to be covered at all times.
 9. Additional SWPPP BMPs shall be implemented as dictated by site conditions and as recommended by the QSP to prevent erosion and pollutant transport.

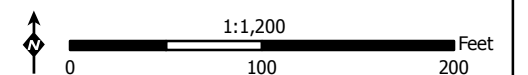



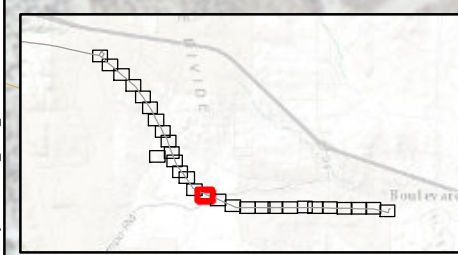





Z:\Projects\SDGE_CNF_ESRPI\MXDs\Plans\SWPPP\TL6931_BMP_Detailed_Route.mxd



Site Map
TL6931 Map 17 of 29

Cleveland National Forest
Power Line Replacement Projects

LUP TYPE I PROJECT

-  Fiber Roll (BMP 1-03)
-  Contour, 20-ft Interval
-  Wood-to-Steel Replacement
-  Wood-to-Steel Replacement
-  Maintained Access Road
-  Guard Structure Work Area
-  Stringing Site
-  Temporary Work Area

- SWPPP Notes:
1. Locations of SWPPP BMPs are not to scale.
 2. SWPPP BMP locations are conceptual in nature and must be field-verified prior to construction.
 3. Erosion and sediment controls shall be deployed prior to pavement removal or soil disturbance (where applicable) and as recommended by the QSP.
 4. SDG&E BMP Details for sediment controls, erosion controls, waste management controls, and non-storm water discharge controls are contained within Appendix XI Construction BMPs of the Project SWPPP.
 5. Preserve existing vegetation within all designated construction areas in accordance with BMP 4-01.
 6. Track-out shall be removed at the end of every business day and as frequently as necessary to keep adjacent roads clean and free of sediment.
 7. Dust control shall be implemented as necessary during construction in accordance with dust (wind erosion) control BMP 4-08.
 8. All trash containers are required to be covered at all times.
 9. Additional SWPPP BMPs shall be implemented as dictated by site conditions and as recommended by the QSP to prevent erosion and pollutant transport.

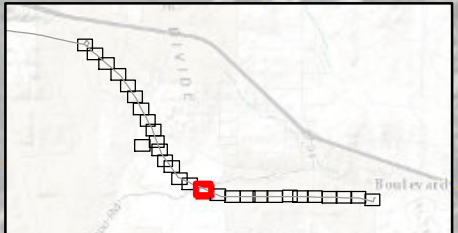
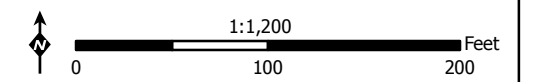















Z:\Projects\SDGE_CNF_ESRPI\MXDs\Plans\SWPPP\TL6931_BMP_Detailed_Route.mxd





Site Map
TL6931 Map 18 of 29



Cleveland National Forest
Power Line Replacement Projects

LUP TYPE I PROJECT

-  Sanitary/Septic Waste Management (BMP 2-07)
-  Gravel Bag
-  Material Delivery and Storage (BMP 2-01)
-  Secondary Containment Required (BMP 2-03)
-  Track-Out Control (BMP-1-07)
-  Fiber Roll (BMP 1-03)
-  Gravel Bag Berm (BMP 1-04)
-  Track-Out Control (BMP 1-07)
-  Contour, 20-ft Interval

-  Pole Top Work Only
-  Removal
-  Replace Tap Pole
-  Wood-to-Steel Replacement
-  Wood-to-Steel Replacement 12 kV Only

-  Wood-to-Steel Replacement
-  Maintained Access Road
-  Navigation Access Road
-  Footpath

-  Anchor Work Area
-  Guard Structure Work Area
-  Staging Area
-  Stringing Site
-  Temporary Work Area

- SWPPP Notes:
1. Locations of SWPPP BMPs are not to scale.
 2. SWPPP BMP locations are conceptual in nature and must be field-verified prior to construction.
 3. Erosion and sediment controls shall be deployed prior to pavement removal or soil disturbance (where applicable) and as recommended by the QSP.
 4. SDG&E BMP Details for sediment controls, erosion controls, waste management controls, and non-storm water discharge controls are contained within Appendix XI Construction BMPs of the Project SWPPP.
 5. Preserve existing vegetation within all designated construction areas in accordance with BMP 4-01.
 6. Track-out shall be removed at the end of every business day and as frequently as necessary to keep adjacent roads clean and free of sediment.
 7. Dust control shall be implemented as necessary during construction in accordance with dust (wind erosion) control BMP 4-08.
 8. All trash containers are required to be covered at all times.
 9. Additional SWPPP BMPs shall be implemented as dictated by site conditions and as recommended by the QSP to prevent erosion and pollutant transport.

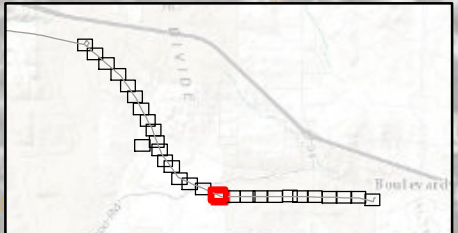
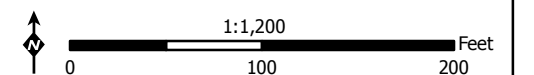









Z:\Projects\SDGE_CNF_ESRPI\MXDs\Plans\SWPPP\TL6931_BMP_Detailed_Route.mxd

Site Map
TL6931 Map 19 of 29

Cleveland National Forest
Power Line Replacement Projects

LUP TYPE | PROJECT

-  Fiber Roll (BMP 1-03)
-  Contour, 20-ft Interval
-  Wood-to-Steel Replacement
-  Wood-to-Steel Replacement
-  Maintained Access Road
-  Navigation Access Road
-  Stringing Site
-  Temporary Work Area

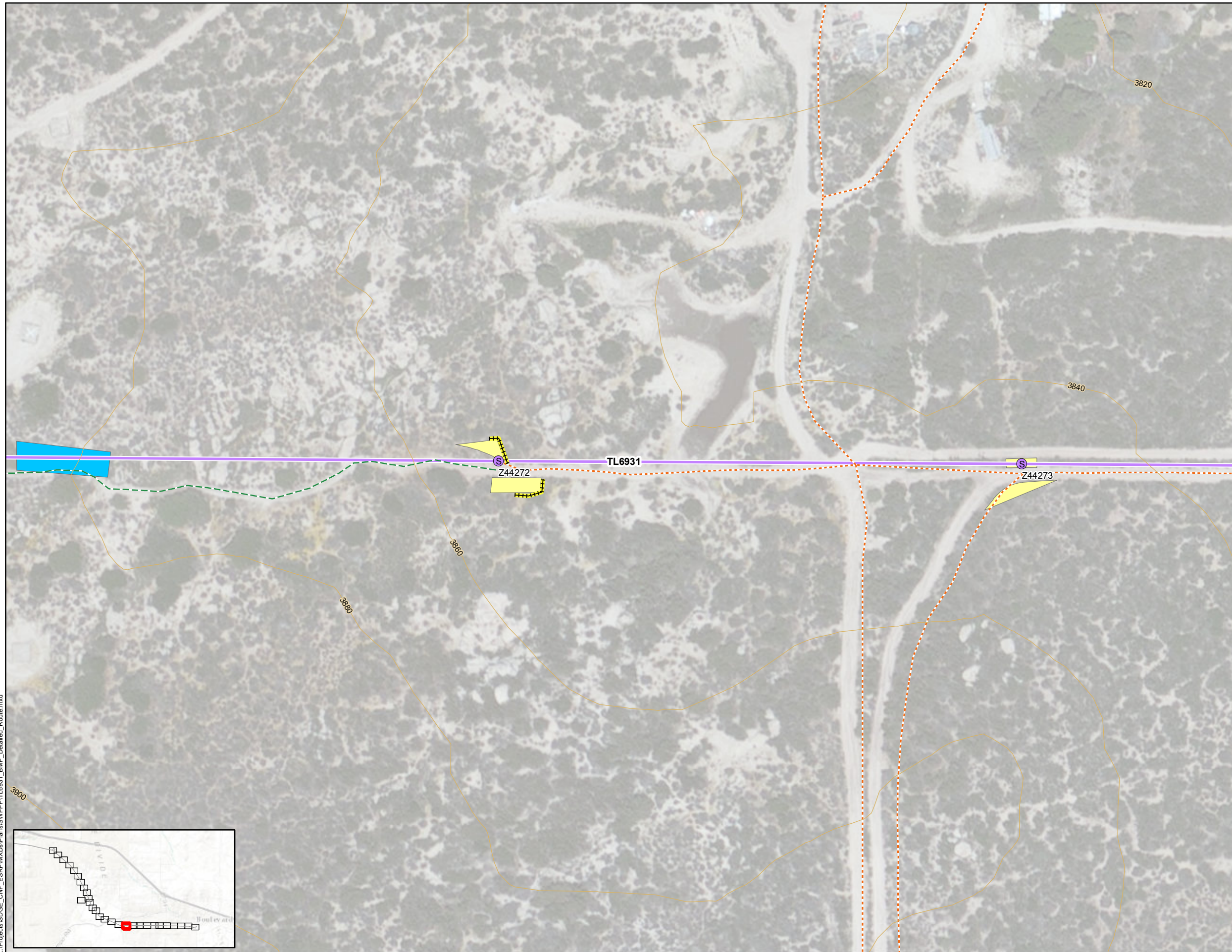

SWPPP Notes:



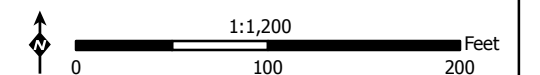





1. Locations of SWPPP BMPs are not to scale.
2. SWPPP BMP locations are conceptual in nature and must be field-verified prior to construction.
3. Erosion and sediment controls shall be deployed prior to pavement removal or soil disturbance (where applicable) and as recommended by the QSP.
4. SDG&E BMP Details for sediment controls, erosion controls, waste management controls, and non-storm water discharge controls are contained within Appendix XI Construction BMPs of the Project SWPPP.
5. Preserve existing vegetation within all designated construction areas in accordance with BMP 4-01.
6. Track-out shall be removed at the end of every business day and as frequently as necessary to keep adjacent roads clean and free of sediment.
7. Dust control shall be implemented as necessary during construction in accordance with dust (wind erosion) control BMP 4-08.
8. All trash containers are required to be covered at all times.
9. Additional SWPPP BMPs shall be implemented as dictated by site conditions and as recommended by the QSP to prevent erosion and pollutant transport.



Site Map
TL6931 Map 20 of 29

Cleveland National Forest
Power Line Replacement Projects

LUP TYPE I PROJECT

-  Fiber Roll (BMP 1-03)
-  Contour, 20-ft Interval
-  Wood-to-Steel Replacement
-  Wood-to-Steel Replacement
-  Maintained Access Road
-  Navigation Access Road
-  Footpath
-  Temporary Work Area
-  Temporary Work Entry

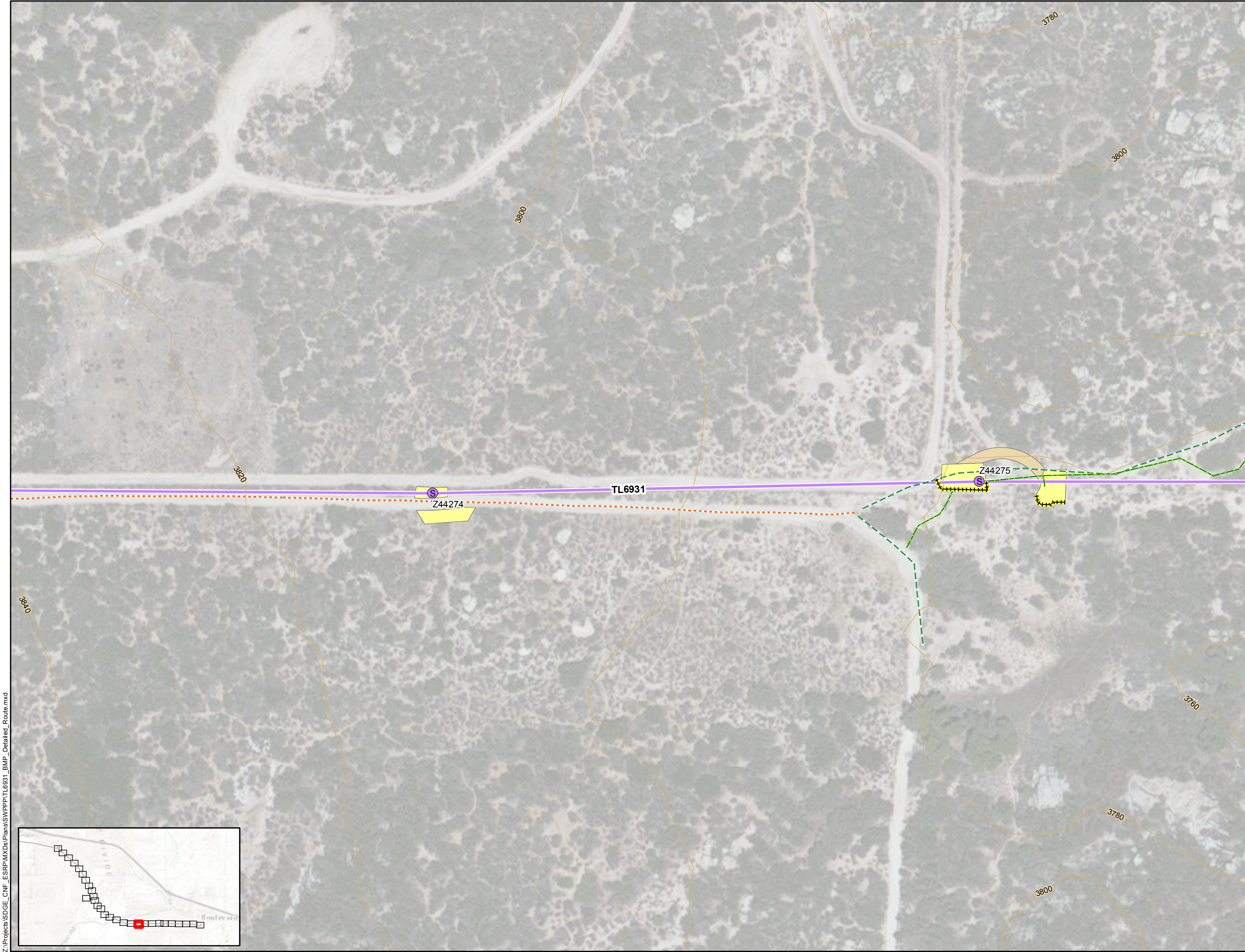

- SWPPP Notes:**
1. Locations of SWPPP BMPs are not to scale.
 2. SWPPP BMP locations are conceptual in nature and must be field-verified prior to construction.
 3. Erosion and sediment controls shall be deployed prior to pavement removal or soil disturbance (where applicable) and as recommended by the QSP.
 4. SDG&E BMP Details for sediment controls, erosion controls, waste management controls, and non-storm water discharge controls are contained within Appendix XI Construction BMPs of the Project SWPPP.
 5. Preserve existing vegetation within all designated construction areas in accordance with BMP 4-01.
 6. Track-out shall be removed at the end of every business day and as frequently as necessary to keep adjacent roads clean and free of sediment.
 7. Dust control shall be implemented as necessary during construction in accordance with dust (wind erosion) control BMP 4-08.
 8. All trash containers are required to be covered at all times.
 9. Additional SWPPP BMPs shall be implemented as dictated by site conditions and as recommended by the QSP to prevent erosion and pollutant transport.

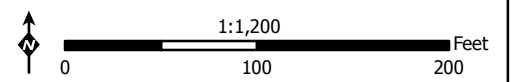



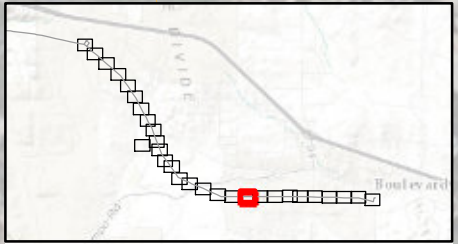







Z:\Projects\SDGE_CNF_ESRPMXD\Plans\SWPPP\TL6931_BMP_Detailed_Route.mxd



Site Map
TL6931 Map 21 of 29

Cleveland National Forest
Power Line Replacement Projects

LUP TYPE I PROJECT

-  Fiber Roll (BMP 1-03)
-  Contour, 20-ft Interval
-  Wood-to-Steel Replacement
-  Wood-to-Steel Replacement
-  Construction Only Access Road
-  Maintained Access Road
-  Navigation Access Road
-  Footpath
-  Anchor Work Area
-  Guard Structure Work Area
-  Temporary Work Area

- SWPPP Notes:
1. Locations of SWPPP BMPs are not to scale.
 2. SWPPP BMP locations are conceptual in nature and must be field-verified prior to construction.
 3. Erosion and sediment controls shall be deployed prior to pavement removal or soil disturbance (where applicable) and as recommended by the QSP.
 4. SDG&E BMP Details for sediment controls, erosion controls, waste management controls, and non-storm water discharge controls are contained within Appendix XI Construction BMPs of the Project SWPPP.
 5. Preserve existing vegetation within all designated construction areas in accordance with BMP 4-01.
 6. Track-out shall be removed at the end of every business day and as frequently as necessary to keep adjacent roads clean and free of sediment.
 7. Dust control shall be implemented as necessary during construction in accordance with dust (wind erosion) control BMP 4-08.
 8. All trash containers are required to be covered at all times.
 9. Additional SWPPP BMPs shall be implemented as dictated by site conditions and as recommended by the QSP to prevent erosion and pollutant transport.

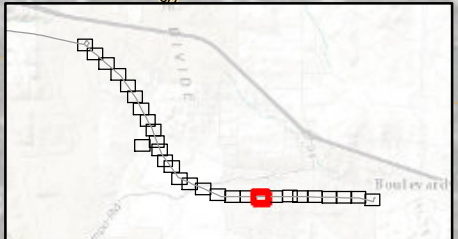
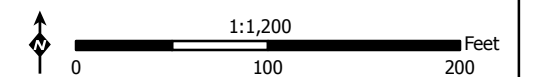









Z:\Projects\SDGE_CNF_ESRPI\XDs\Plans\SWPPP\TL6931_BMP_Detailed_Route.mxd

Site Map
TL6931 Map 22 of 29

Cleveland National Forest
Power Line Replacement Projects

LUP TYPE I PROJECT

-  Fiber Roll (BMP 1-03)
-  Contour, 20-ft Interval
-  Wood-to-Steel Replacement
-  Wood-to-Steel Replacement
-  Maintained Access Road
-  Footpath
-  Anchor Work Area
-  Temporary Work Area

- SWPPP Notes:
1. Locations of SWPPP BMPs are not to scale.
 2. SWPPP BMP locations are conceptual in nature and must be field-verified prior to construction.
 3. Erosion and sediment controls shall be deployed prior to pavement removal or soil disturbance (where applicable) and as recommended by the QSP.
 4. SDG&E BMP Details for sediment controls, erosion controls, waste management controls, and non-storm water discharge controls are contained within Appendix XI Construction BMPs of the Project SWPPP.
 5. Preserve existing vegetation within all designated construction areas in accordance with BMP 4-01.
 6. Track-out shall be removed at the end of every business day and as frequently as necessary to keep adjacent roads clean and free of sediment.
 7. Dust control shall be implemented as necessary during construction in accordance with dust (wind erosion) control BMP 4-08.
 8. All trash containers are required to be covered at all times.
 9. Additional SWPPP BMPs shall be implemented as dictated by site conditions and as recommended by the QSP to prevent erosion and pollutant transport.

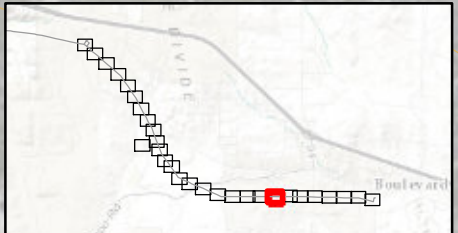
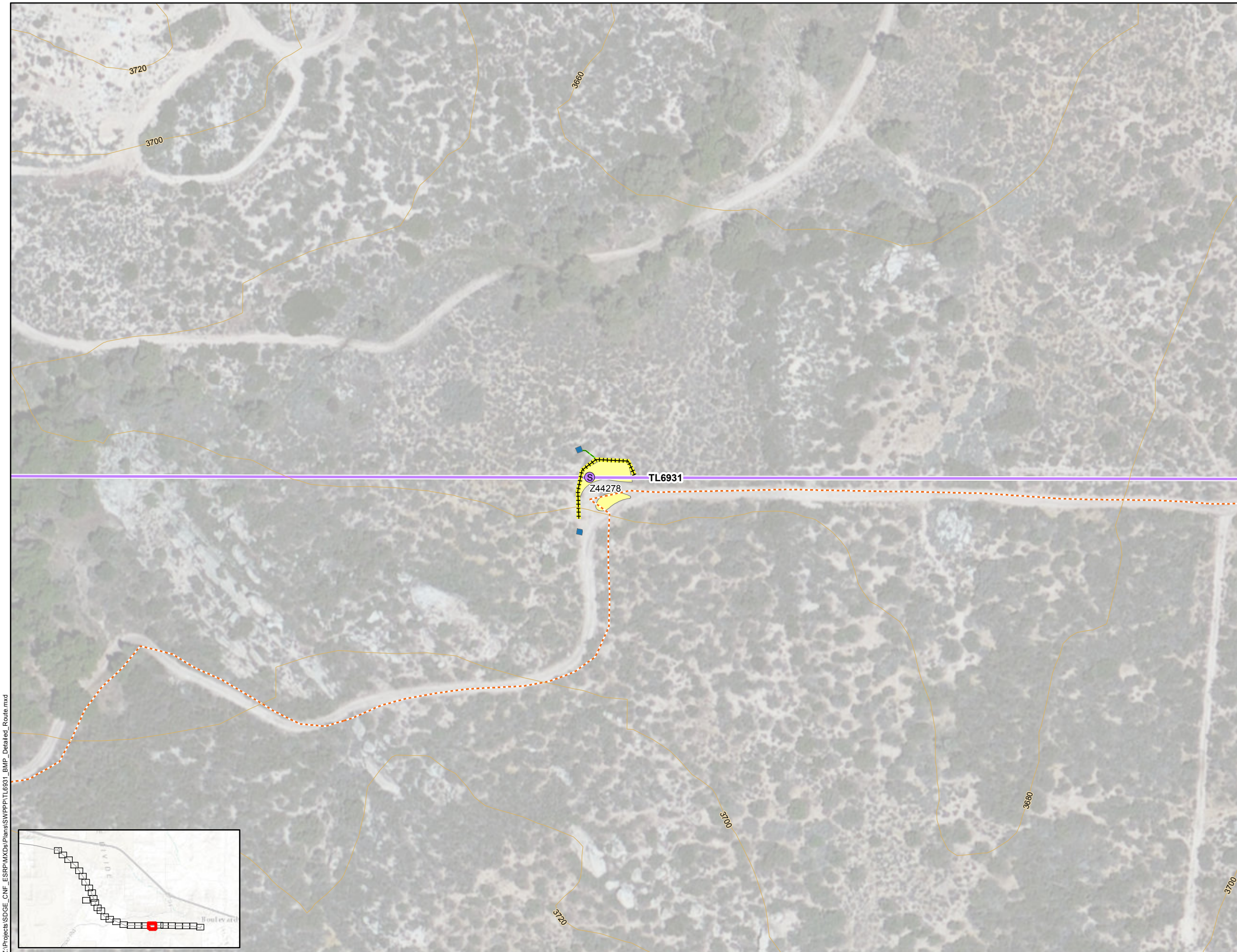
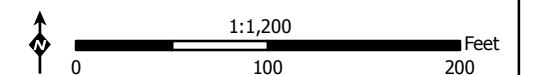







Z:\Projects\SDGE_CNF_ESRPI\MXDs\Plans\SWPPP\TL6931_BMP_Detailed_Route.mxd

Site Map
TL6931 Map 23 of 29

Cleveland National Forest
Power Line Replacement Projects

LUP TYPE I PROJECT

-  Fiber Roll (BMP 1-03)
-  Contour, 20-ft Interval
-  Wood-to-Steel Replacement
-  Wood-to-Steel Replacement
-  Maintained Access Road
-  Stringing Site
-  Temporary Work Area

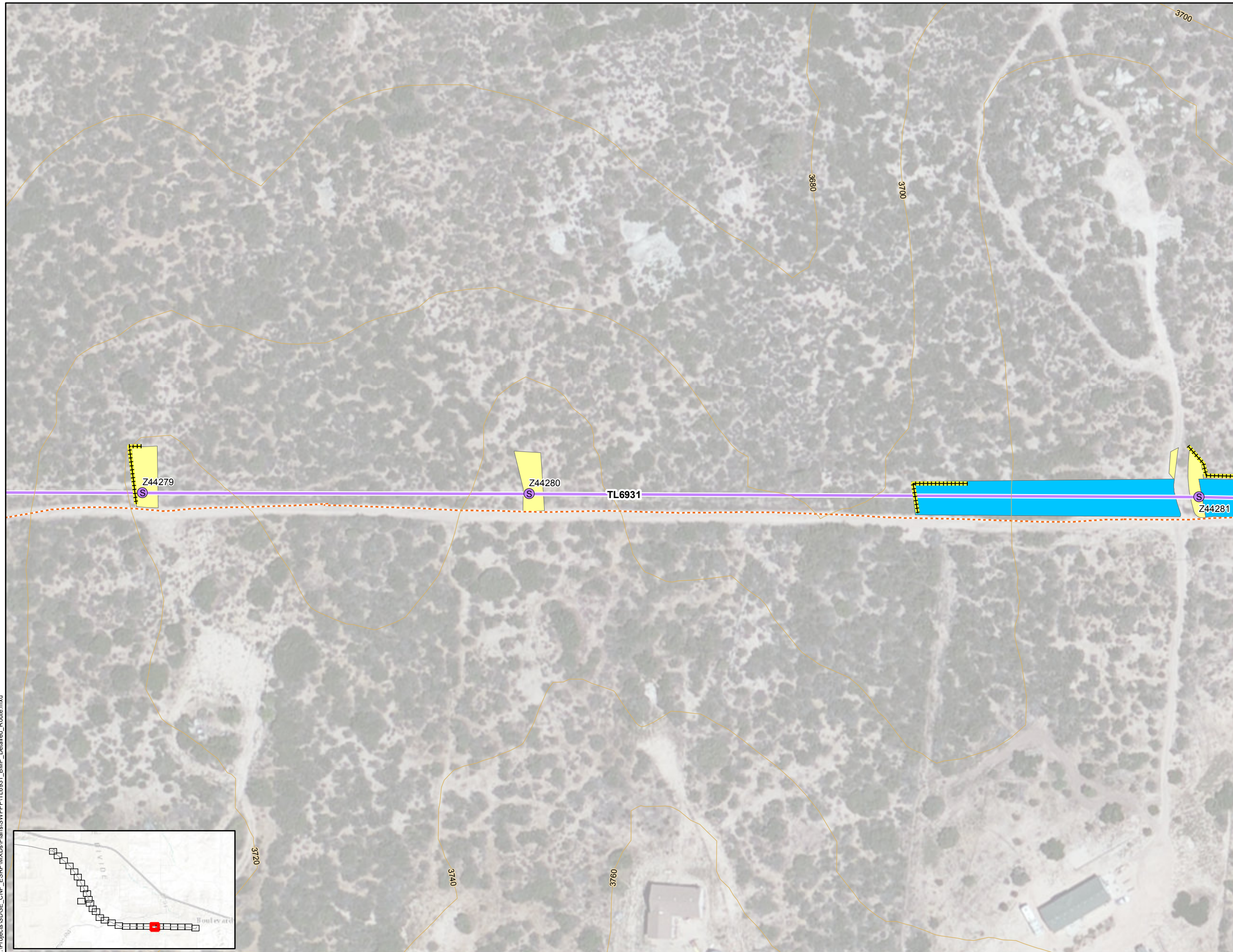

SWPPP Notes:



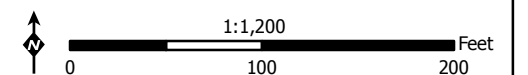





1. Locations of SWPPP BMPs are not to scale.
2. SWPPP BMP locations are conceptual in nature and must be field-verified prior to construction.
3. Erosion and sediment controls shall be deployed prior to pavement removal or soil disturbance (where applicable) and as recommended by the QSP.
4. SDG&E BMP Details for sediment controls, erosion controls, waste management controls, and non-storm water discharge controls are contained within Appendix XI Construction BMPs of the Project SWPPP.
5. Preserve existing vegetation within all designated construction areas in accordance with BMP 4-01.
6. Track-out shall be removed at the end of every business day and as frequently as necessary to keep adjacent roads clean and free of sediment.
7. Dust control shall be implemented as necessary during construction in accordance with dust (wind erosion) control BMP 4-08.
8. All trash containers are required to be covered at all times.
9. Additional SWPPP BMPs shall be implemented as dictated by site conditions and as recommended by the QSP to prevent erosion and pollutant transport.



Site Map
TL6931 Map 24 of 29

Cleveland National Forest
Power Line Replacement Projects

LUP TYPE I PROJECT

-  Fiber Roll (BMP 1-03)
-  Contour, 20-ft Interval
-  Wood-to-Steel Replacement
-  Wood-to-Steel Replacement
-  Maintained Access Road
-  Footpath
-  Anchor Work Area
-  Stringing Site
-  Temporary Work Area

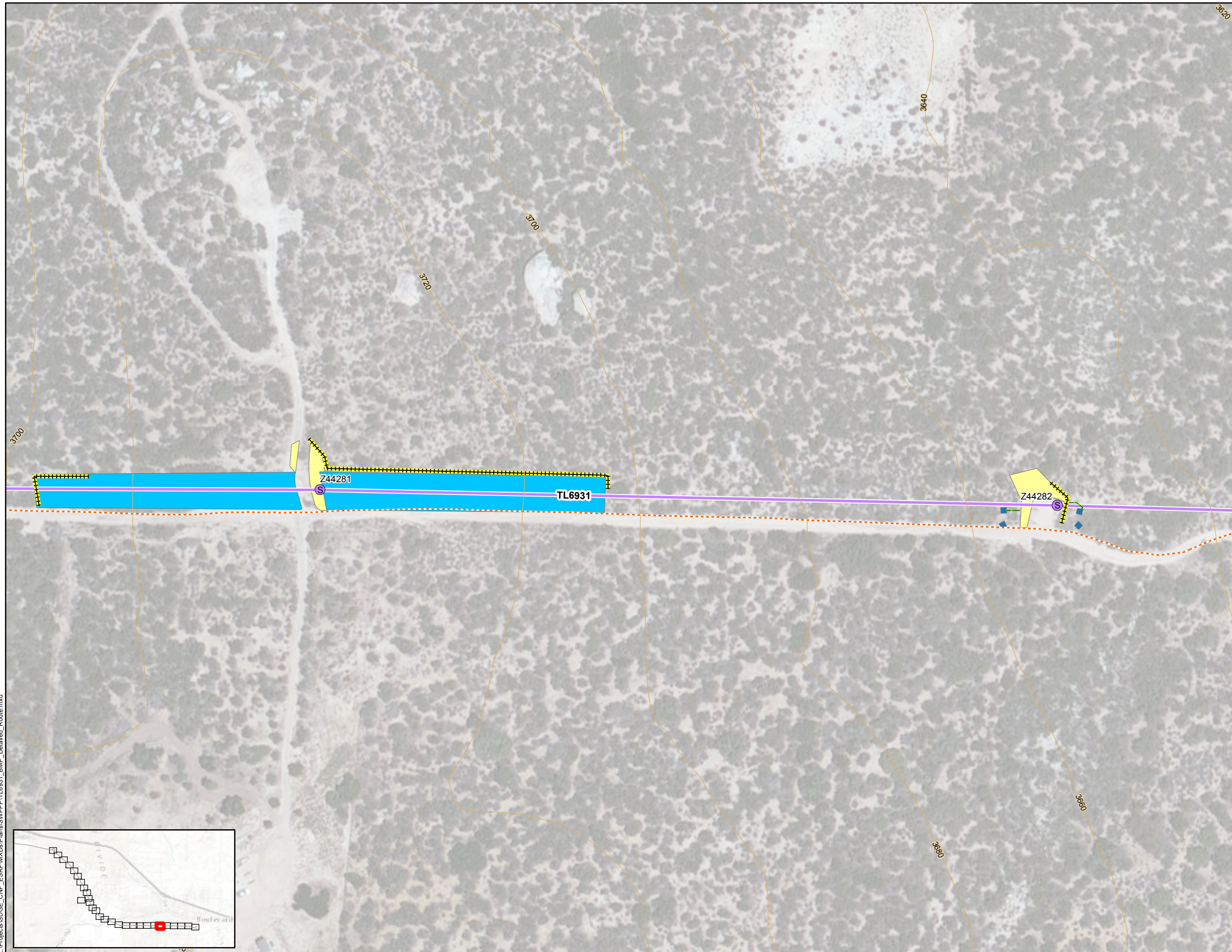

- SWPPP Notes:
1. Locations of SWPPP BMPs are not to scale.
 2. SWPPP BMP locations are conceptual in nature and must be field-verified prior to construction.
 3. Erosion and sediment controls shall be deployed prior to pavement removal or soil disturbance (where applicable) and as recommended by the QSP.
 4. SDG&E BMP Details for sediment controls, erosion controls, waste management controls, and non-storm water discharge controls are contained within Appendix XI Construction BMPs of the Project SWPPP.
 5. Preserve existing vegetation within all designated construction areas in accordance with BMP 4-01.
 6. Track-out shall be removed at the end of every business day and as frequently as necessary to keep adjacent roads clean and free of sediment.
 7. Dust control shall be implemented as necessary during construction in accordance with dust (wind erosion) control BMP 4-08.
 8. All trash containers are required to be covered at all times.
 9. Additional SWPPP BMPs shall be implemented as dictated by site conditions and as recommended by the QSP to prevent erosion and pollutant transport.

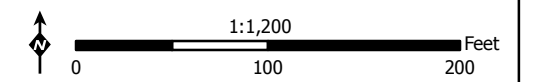



Site Map
TL6931 Map 25 of 29

Cleveland National Forest
Power Line Replacement Projects

LUP TYPE I PROJECT

-  Fiber Roll (BMP 1-03)
-  Track-Out Control (BMP 1-07)
-  Contour, 20-ft Interval

-  Wood-to-Steel Replacement
-  Wood-to-Steel Replacement
-  Maintained Access Road
-  Anchor Work Area
-  Guard Structure Work Area
-  Stringing Site
-  Temporary Work Area

- SWPPP Notes:
1. Locations of SWPPP BMPs are not to scale.
 2. SWPPP BMP locations are conceptual in nature and must be field-verified prior to construction.
 3. Erosion and sediment controls shall be deployed prior to pavement removal or soil disturbance (where applicable) and as recommended by the QSP.
 4. SDG&E BMP Details for sediment controls, erosion controls, waste management controls, and non-storm water discharge controls are contained within Appendix XI Construction BMPs of the Project SWPPP.
 5. Preserve existing vegetation within all designated construction areas in accordance with BMP 4-01.
 6. Track-out shall be removed at the end of every business day and as frequently as necessary to keep adjacent roads clean and free of sediment.
 7. Dust control shall be implemented as necessary during construction in accordance with dust (wind erosion) control BMP 4-08.
 8. All trash containers are required to be covered at all times.
 9. Additional SWPPP BMPs shall be implemented as dictated by site conditions and as recommended by the QSP to prevent erosion and pollutant transport.

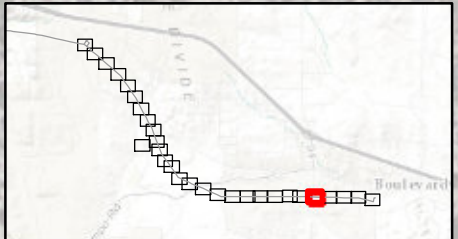
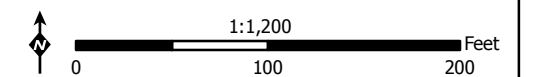









Z:\Projects\SDGE_CNF_ESRP\MXDs\Plans\SWPPP\TL6931_BMP_Detailed_Route.mxd

Site Map
TL6931 Map 26 of 29

Cleveland National Forest
Power Line Replacement Projects

LUP TYPE I PROJECT

-  Fiber Roll (BMP 1-03)
-  Contour, 20-ft Interval
-  Wood-to-Steel Replacement
-  Wood-to-Steel Replacement
-  Maintained Access Road
-  Navigation Access Road
-  Anchor Work Area
-  Temporary Work Area



- SWPPP Notes:**
1. Locations of SWPPP BMPs are not to scale.
 2. SWPPP BMP locations are conceptual in nature and must be field-verified prior to construction.
 3. Erosion and sediment controls shall be deployed prior to pavement removal or soil disturbance (where applicable) and as recommended by the QSP.
 4. SDG&E BMP Details for sediment controls, erosion controls, waste management controls, and non-storm water discharge controls are contained within Appendix XI Construction BMPs of the Project SWPPP.
 5. Preserve existing vegetation within all designated construction areas in accordance with BMP 4-01.
 6. Track-out shall be removed at the end of every business day and as frequently as necessary to keep adjacent roads clean and free of sediment.
 7. Dust control shall be implemented as necessary during construction in accordance with dust (wind erosion) control BMP 4-08.
 8. All trash containers are required to be covered at all times.
 9. Additional SWPPP BMPs shall be implemented as dictated by site conditions and as recommended by the QSP to prevent erosion and pollutant transport.

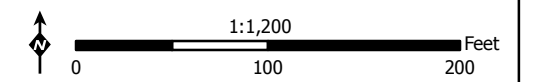



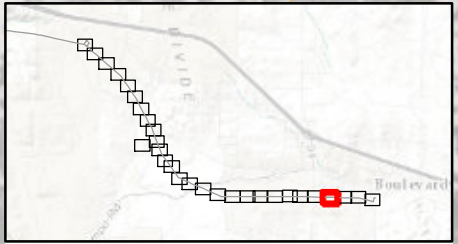





Z:\Projects\SDGE_CNF_ESRPMXD\Plans\SWPPP\TL6931_BMP_Detailed_Route.mxd



Site Map
TL6931 Map 27 of 29

Cleveland National Forest
Power Line Replacement Projects

LUP TYPE I PROJECT

-  Fiber Roll (BMP 1-03)
-  Contour, 20-ft Interval
-  Wood-to-Steel Replacement
-  Wood-to-Steel Replacement
-  Maintained Access Road
-  Navigation Access Road
-  Anchor Work Area
-  Stringing Site
-  Temporary Work Area

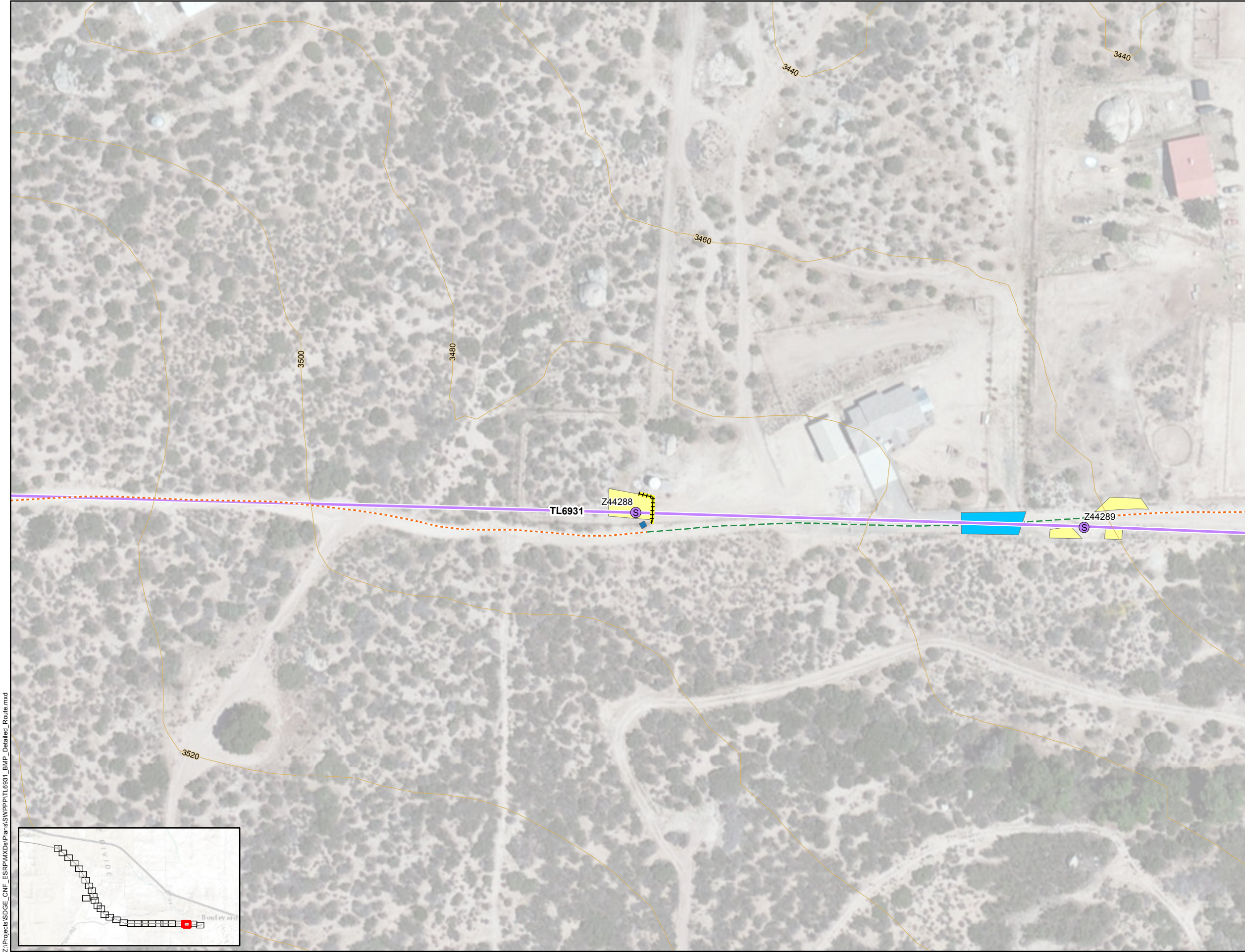

- SWPPP Notes:**
1. Locations of SWPPP BMPs are not to scale.
 2. SWPPP BMP locations are conceptual in nature and must be field-verified prior to construction.
 3. Erosion and sediment controls shall be deployed prior to pavement removal or soil disturbance (where applicable) and as recommended by the QSP.
 4. SDG&E BMP Details for sediment controls, erosion controls, waste management controls, and non-storm water discharge controls are contained within Appendix XI Construction BMPs of the Project SWPPP.
 5. Preserve existing vegetation within all designated construction areas in accordance with BMP 4-01.
 6. Track-out shall be removed at the end of every business day and as frequently as necessary to keep adjacent roads clean and free of sediment.
 7. Dust control shall be implemented as necessary during construction in accordance with dust (wind erosion) control BMP 4-08.
 8. All trash containers are required to be covered at all times.
 9. Additional SWPPP BMPs shall be implemented as dictated by site conditions and as recommended by the QSP to prevent erosion and pollutant transport.

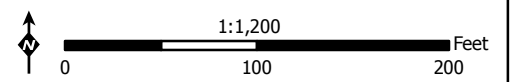







Z:\Projects\SDGE_CNF_ESRPMX\Plans\SWPPP\TL6931_BMP_Detailed_Route.mxd

Site Map
TL6931 Map 28 of 29

Cleveland National Forest
Power Line Replacement Projects

LUP TYPE I PROJECT

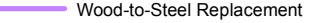
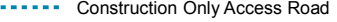
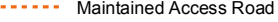
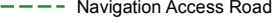
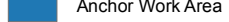
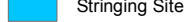
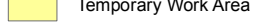
-  Fiber Roll (BMP 1-03)
-  Contour, 20-ft Interval
-  Removal
-  Replace Tap Pole
-  Wood-to-Steel Replacement
-  Wood-to-Steel Replacement 12 kV Only
-  Wood-to-Steel Replacement
-  Construction Only Access Road
-  Maintained Access Road
-  Navigation Access Road
-  Anchor Work Area
-  Stringing Site
-  Temporary Work Area

- SWPPP Notes:
1. Locations of SWPPP BMPs are not to scale.
 2. SWPPP BMP locations are conceptual in nature and must be field-verified prior to construction.
 3. Erosion and sediment controls shall be deployed prior to pavement removal or soil disturbance (where applicable) and as recommended by the QSP.
 4. SDG&E BMP Details for sediment controls, erosion controls, waste management controls, and non-storm water discharge controls are contained within Appendix XI Construction BMPs of the Project SWPPP.
 5. Preserve existing vegetation within all designated construction areas in accordance with BMP 4-01.
 6. Track-out shall be removed at the end of every business day and as frequently as necessary to keep adjacent roads clean and free of sediment.
 7. Dust control shall be implemented as necessary during construction in accordance with dust (wind erosion) control BMP 4-08.
 8. All trash containers are required to be covered at all times.
 9. Additional SWPPP BMPs shall be implemented as dictated by site conditions and as recommended by the QSP to prevent erosion and pollutant transport.

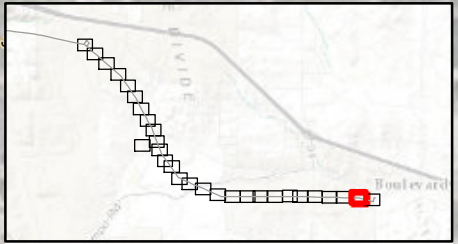
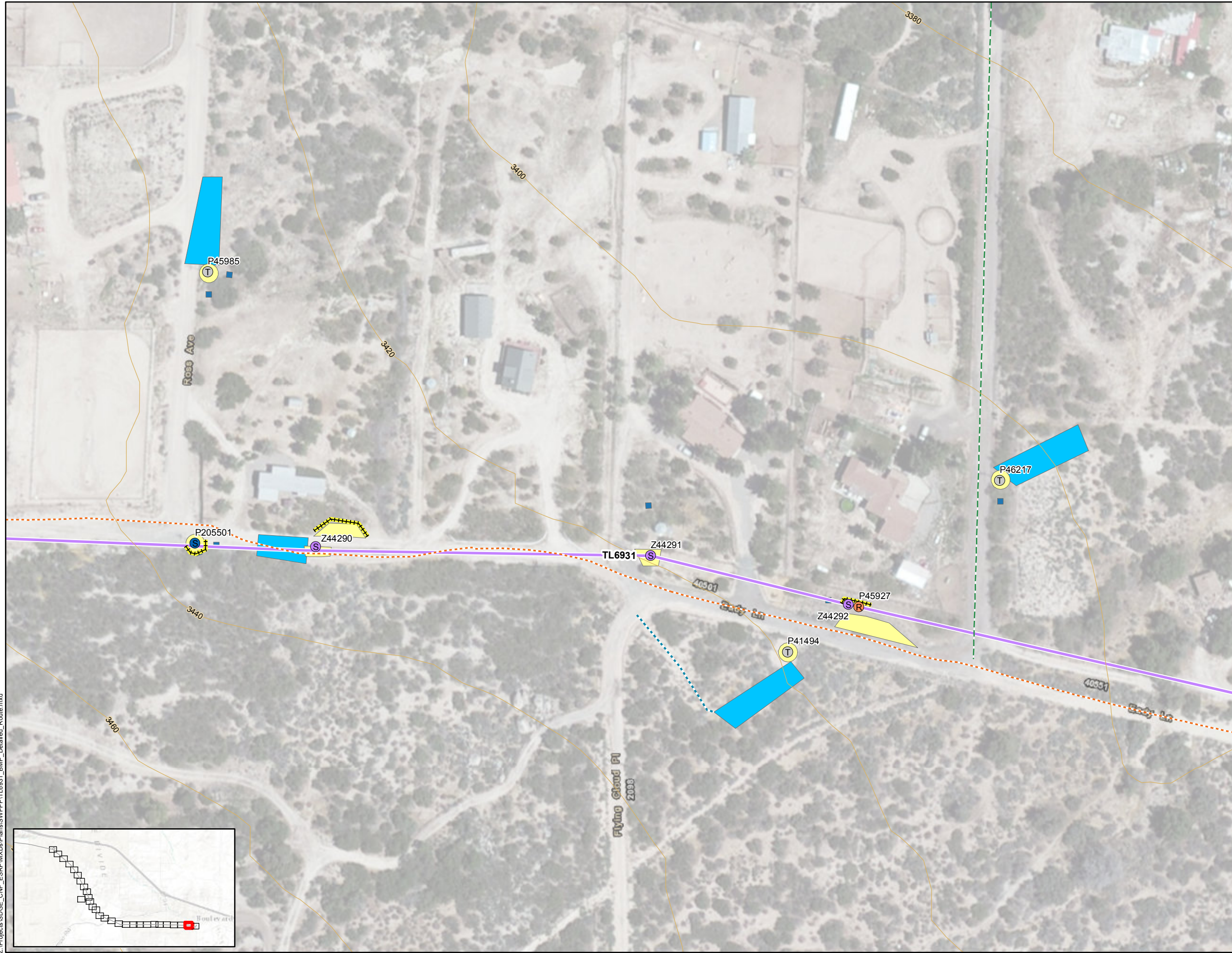
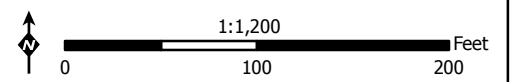

















Z:\Projects\SDGE_CNF_ESRPI\MXDs\Plans\SWPPP\TL6931_L_BMP_Detailed_Route.mxd

Site Map
TL6931 Map 29 of 29

Cleveland National Forest
Power Line Replacement Projects

LUP TYPE I PROJECT

-  Fiber Roll (BMP 1-03)
-  Silt Fence (BMP 1-02)
-  Track-Out Control (BMP 1-07)
-  Contour, 20-ft Interval

-  Pole Top Work Only
-  Replace Tap Pole
-  Wood-to-Steel Replacement
-  Wood-to-Steel Replacement
-  Maintained Access Road
-  Navigation Access Road
-  Footpath
-  Anchor Work Area
-  Staging Area
-  Stringing Site
-  Temporary Work Area
-  Temporary Work Entry

- SWPPP Notes:
1. Locations of SWPPP BMPs are not to scale.
 2. SWPPP BMP locations are conceptual in nature and must be field-verified prior to construction.
 3. Erosion and sediment controls shall be deployed prior to pavement removal or soil disturbance (where applicable) and as recommended by the QSP.
 4. SDG&E BMP Details for sediment controls, erosion controls, waste management controls, and non-storm water discharge controls are contained within Appendix XI Construction BMPs of the Project SWPPP.
 5. Preserve existing vegetation within all designated construction areas in accordance with BMP 4-01.
 6. Track-out shall be removed at the end of every business day and as frequently as necessary to keep adjacent roads clean and free of sediment.
 7. Dust control shall be implemented as necessary during construction in accordance with dust (wind erosion) control BMP 4-08.
 8. All trash containers are required to be covered at all times.
 9. Additional SWPPP BMPs shall be implemented as dictated by site conditions and as recommended by the QSP to prevent erosion and pollutant transport.

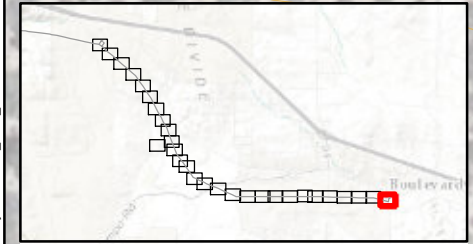
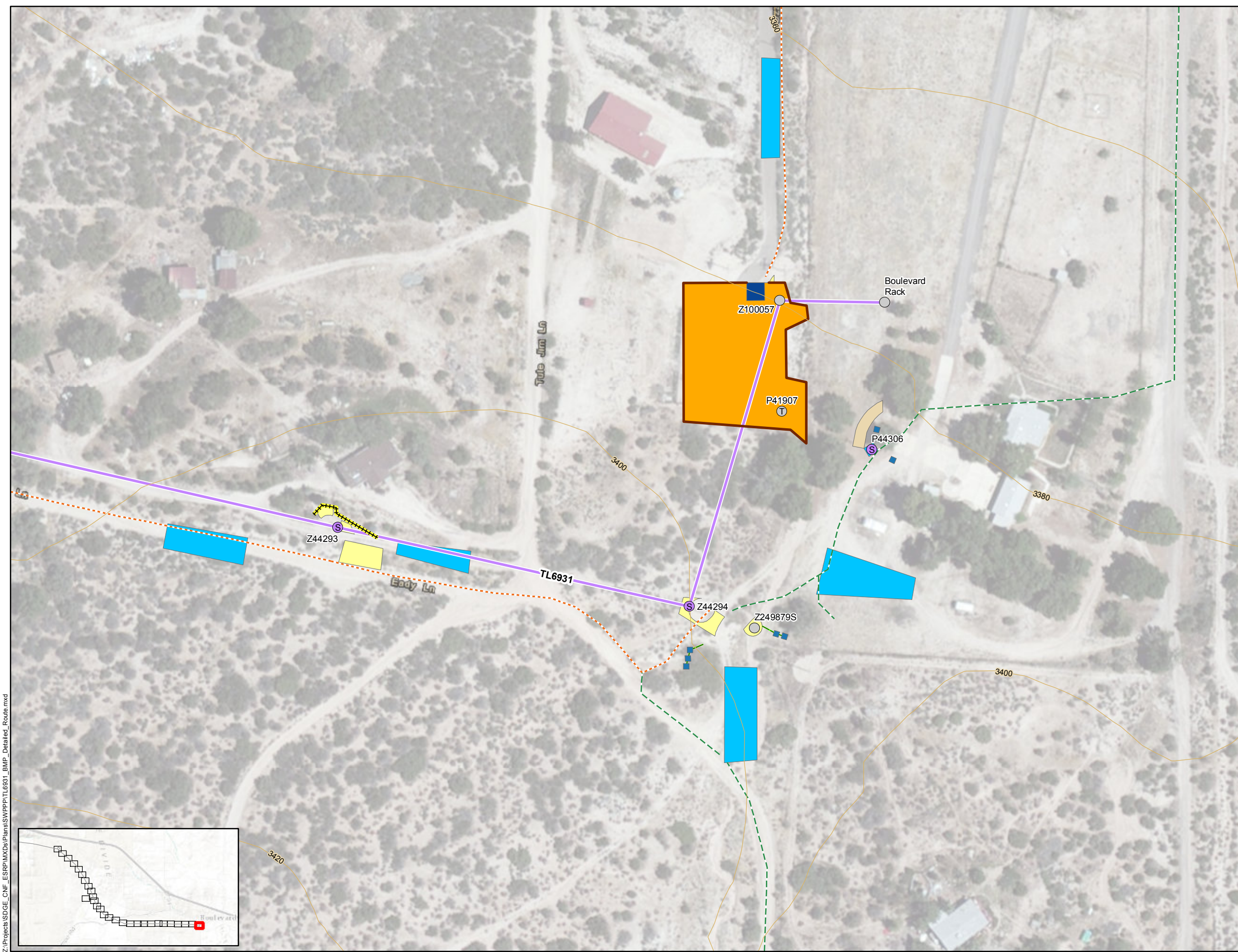
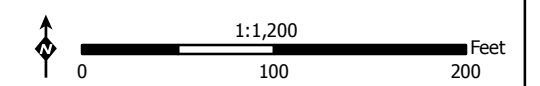

Z:\Projects\SDGE_CNF_ESR\IMX\Plans\SWPPP\TL6931_BMP_Detailed_Route.mxd

ATTACHMENT D-4: TL626A, TL626B, TL625D, AND C157 SWPPP BMP SITE MAP

**[INSERT TL626A, TL626B, TL625D, and C157 SWPPP BMP SITE MAP PRIOR TO THE
COMMENCEMENT OF CONSTRUCTION]**

ATTACHMENT D-5: C440, C442, TL629A SWPPP BMP SITE MAP

**[INSERT C440, C442, AND TL629A SWPPP BMP SITE MAP PRIOR TO THE
COMMENCEMENT OF CONSTRUCTION]**

ATTACHMENT D-6: C222, C79B, C449, TL629C, AND TL629D SWPPP BMP SITE MAP

**[INSERT C222, C79B, C449, TL629C, AND TL629D SWPPP BMP SITE MAP PRIOR TO THE
COMMENCEMENT OF CONSTRUCTION]**

ATTACHMENT D-7: TL625C AND TL6923 SWPPP BMP SITE MAP

**[INSERT TL625C AND TL6923 SWPPP BMP SITE MAP PRIOR TO THE COMMENCEMENT
OF CONSTRUCTION]**

