

B. PROJECT DESCRIPTION

B.1 Introduction

Section B describes the East County (ECO) Substation Project as proposed by the San Diego Gas & Electric Company (SDG&E), the Tule Wind Project as proposed by ~~Tule Wind, LLC~~ Pacific Wind Development, and the Energia Sierra Juarez U.S. Generator-Tie (ESJ Gen-Tie) Project as proposed by Energia Sierra Juarez U.S. Transmission, LLC. In addition, the proposed Invenergy and SDG&E Campo Wind Project, Manzanita Wind Project, and Jordan Wind Project, which would connect to the Boulevard Substation Rebuild, are viewed as reasonably foreseeable and are qualitatively evaluated at a programmatic level. The potential environmental effects of the three separate projects as described here are analyzed in Section D. It should be noted that each project described has discreet components and will be implemented independently by each project proponent. Section B.2 provides a general overview of the ECO Substation, Tule Wind, and ESJ Gen-Tie projects, collectively referred to as the Proposed PROJECT. Section B.3 describes the ECO Substation Project, Section B.4 describes the Tule Wind Project, and Section B.5 describes the ESJ Gen-Tie Project. Section B.6 lists the references cited in this section.

B.2 Overview of the Proposed Project

The Proposed PROJECT would be located in southeastern San Diego County, approximately 70 miles east of Downtown San Diego, in the vicinity of the unincorporated communities of Jacumba and Boulevard (Figures B-1, Regional Map, and B-2B, Vicinity/Overview Map).

Table B-1, Overview of the ECO Substation, Tule Wind, and ESJ Gen-Tie Projects, lists the major components of each project as well as the associated approximate permanent and temporary impacts. Because sufficient project-level information has yet to be developed for the proposed Campo, Manzanita, and Jordan wind energy projects, temporary and permanent impacts for these projects are not included.

Table B-1
Overview of the ECO Substation, Tule Wind, and ESJ Gen-Tie Projects

Project Component	Approximate Temporary Impacts (acres)	Approximate Permanent Impacts (acres)
ECO Substation Project		
ECO Substation 500/230/138-kilovolt (kV) Substation	26.15	85.9
SWPL Loop-In	0	1.74
13.3-Mile Overhead 138 kV Transmission Line	22.54	11.06
Boulevard Substation Rebuild	0	3.2
Access Roads	0	8.45
<i>ECO Substation Project Total</i>	48.69	110.35

East County Substation/Tule Wind/Energia Sierra Juarez Gen-Tie Projects
B. PROJECT DESCRIPTION

Table B-1 (Continued)

Project Component	Approximate Temporary Impacts (acres)	Approximate Permanent Impacts (acres)
Tule Wind Project		
134-128 Wind Turbines (1.5 to 3.0 megawatt (MW))	0	386369.35
Overhead and Underground 34.5 kV Collector Cable System	408.2127	0.02
Collector Substation	0	5
Operations and Maintenance Facility	0	5
Overhead 138 kV Transmission Line	44.640.3	0.1209
Meteorological Towers and SODAR or LIDAR Units	0.048064	0.062083
Access Roads	84.283.5	166.1152.6
Temporary Construction Areas (parking area, concrete batch plant, and laydown areas)	53	0
<i>Tule Wind Project Total</i>	290303.9.4 (224.4212.1) ¹	562.8532.1 (544513.3) ¹
ESJ Gen-Tie Project		
500 kV Gen-Tie Route		
Steel Lattice Towers/Monopoles	0	3.45
Gen-Tie Tower Access Road	0	0.8
28-Foot Property Legal Access Road and Turnaround	0	4.5
Construction Laydown/Parking/Stringing Area	0	1.9
150-Foot by 20-Foot Access Road to Existing Water Well	0.063	0
<i>ESJ 500 kV Gen-Tie Project Total</i>	0.063	10.65
230 kV Gen-Tie Route		
Steel Lattice Towers/Monopoles	0	2.2
Gen-Tie Tower Access Road	0	0.9
28-Foot Property Legal Access Road and Turnaround	0	4.5
Construction Laydown/Parking/Stringing Area	0	2.0
150-Foot by 20-Foot Access Road to Existing Water Well	0.063	0
<i>ESJ 230 kV Gen-Tie Project Total</i>	0	9.6
Proposed PROJECT (COMBINED)¹		
<i>ECO Substation, Tule Wind, and ESJ Gen-Tie (500 kV Route) Projects Total</i>	338352.879 (273.0960.9)	68353.81 (665634.3)
<i>ECO Substation, Tule Wind, and ESJ Gen-Tie (230 kV Route) Projects Total</i>	338352.79.8 (26073.09)	682652.75.1 (663633.953)

¹ There is a difference between the impacts for each project component and the total disturbed area due to the fact that some project components fall into the same disturbance footprint, thus creating overlap. This overlap gives a higher calculation that ~~distorts~~ overstates the overall project surface land disturbances. The total provided in parenthesis is the proper calculated total with the overlapping areas removed; however, the total disturbed area has been retained in the table.

Sections B.2.1, B.2.2, and B.2.3 provide an overview of the proposed ECO Substation, Tule Wind, and ESJ Gen-Tie projects. Section B.2.4 provides an overview of the proposed Campo, Manzanita, and Jordan wind energy projects. For purposes of this EIR/EIS, the Campo, Manzanita, and Jordan projects are evaluated at a programmatic level because sufficient project-level information has yet to be developed.

B.2.1 SDG&E's ECO Substation Project

The proposed ECO Substation Project would provide an interconnection hub for renewable generation along SDG&E's existing Southwest Powerlink (SWPL) 500-kilovolt (kV) transmission line. In addition to accommodating the region's planned renewable generation, the project would also provide a second source for the southeastern 69 kV transmission system that avoids the vulnerability of common structure outages, which would increase the reliability of electrical service for Boulevard, Jacumba, and surrounding communities. The proposed project would provide interconnection capability at three voltage levels (500, 230, and 138 kV), which would provide renewable generators the option to connect at a voltage level that is appropriately sized for their project.

As proposed by SDG&E, the ECO Substation Project includes the following major components:

- Construction of a 500/230/138 kV substation in southeastern San Diego County
- Construction of the SWPL loop-in, a short loop-in of the existing SWPL transmission line to the proposed ECO Substation
- Construction of a 138 kV transmission line, approximately 13.3 miles in length, running between the proposed ECO Substation and the rebuilt Boulevard Substation
- Rebuild of the existing Boulevard Substation.

Figure B-2B, Vicinity/Overview Map, shows major project components. See Section B.3 for project details.

The ECO Substation, SWPL loop-in, and Boulevard Substation would be located on private lands owned by SDG&E or within SDG&E easements within unincorporated San Diego County (Figure B-2B, Vicinity/Overview Map). The 13.3-mile, 138 kV transmission line would primarily be located on private lands within unincorporated San Diego County with a 1.5-mile portion located on Bureau of Land Management (BLM)-administered land.

Construction of the ECO Substation Project would take approximately 2 years and would require approximately 30 million gallons of water and approximately 1.268 million cubic yards (CY) of earthwork. During peak periods of construction, approximately 89 workers per day would be

working throughout the project area at various project sites. Upon completion, project facilities would be monitored remotely from SDG&E's central operations facility and routine maintenance and repairs would be conducted by existing SDG&E employees.

B.2.2 Tule Wind, LLC~~Pacific Wind Development's~~ Tule Wind Project

The proposed Tule Wind Project would produce up to ~~200-201~~ megawatts (MW) of wind energy. As proposed by Tule Wind, LLC~~Pacific Wind Development~~, the Tule Wind Project would consist of up to ~~134-128~~ wind turbines in the 1.5 to 3.0 MW generating capacity range. In addition to wind turbines and associated generator step-up transformers, the Tule Wind Project would include the following components:

- A 34.5 kV overhead and underground collector cable system linking the wind turbines to the collector substation
- A 5-acre collector substation site and a 5-acre operations and maintenance (O&M) building site
- ~~Two-Three~~ permanent meteorological (MET) towers and one sonic detecting and ranging (SODAR) unit or one light detecting and ranging (LIDAR) unit
- A 138 kV overhead transmission line running south from the collector substation to be interconnected with the rebuilt SDG&E Boulevard Substation
- ~~36.76-38-~~miles of newly constructed access roads and ~~27.62~~23.44 miles of temporarily widened and improved existing access roads.

Figure B-2B, Vicinity/Overview Map, shows major project components. See Section B.4 for project details.

The Tule Wind Project would be primarily located in the In-Ko-Pah Mountains near the McCain Valley in southeastern San Diego County (Figure B-2B, Vicinity/Overview Map). The project would be located on lands administered by the BLM, Ewiiapaayp Indian Reservation, Manzanita and Campo Indian Reservations (access only), and the California State Lands Commission (CSLC), as well as private land under the jurisdiction of San Diego County.

Construction of the Tule Wind Project would take approximately 2 years and would employ up to 325 workers per day during the peak construction period. Construction of the Tule Wind Project would require approximately ~~47.5~~19 million gallons of water and approximately 3.55 million CY of earthwork (3.55 million CY includes 1.0 million CY attributed to rock excavation). Depending on the specific stage of construction, an average daily peak workforce of 125 workers would be present at the construction site and up to 200 delivery trucks are

anticipated. Once completed, O&M staff consisting of up to 12 full-time workers would monitor project components from the proposed O&M facility.

B.2.3 Energia Sierra Juarez U.S. Transmission, LLC's ESJ Gen-Tie Project

As proposed, the ESJ Gen-Tie Project would have the capacity to import up to 1,250 MW of renewable energy generated in northern Baja California, Mexico as part of the ESJ Wind Phase I Project, to the existing SWPL Transmission Line in southeastern San Diego County, California. The proposed route would interconnect with the proposed ECO Substation and would be constructed on three to five 150-foot lattice towers or 170-foot steel monopoles, extending south from the point of interconnection for less than one mile to the U.S.–Mexico international border. The ESJ Gen-Tie Project would be located on private land primarily owned by Energia Sierra Juarez U.S. Transmission, LLC, and the remaining land would be owned by SDG&E. In addition, approximately 4 miles east of ESJ Gen-Tie site, a new access route (150 feet by 20 feet) is proposed from Old Highway 80 to an existing well site. Both the access route and well site are owned by the Jacumba Community Services District (AECOM 2011a, 2011b). ~~Only renewable energy would be transmitted via the gen-tie line.~~ The U.S portion of the ESJ Gen-Tie Project would be located entirely within San Diego County to the east of Jacumba (Figure B-2B, Vicinity/Overview Map). This EIR/EIS will address the proposed gen-tie line, including any potential impacts to the United States associated with the wind turbines located in Mexico. Potential impacts have been identified relating to biological resources, visual resources, and risk from fire.

Construction of the ESJ Gen-Tie Project would take approximately 6 months, and would require approximately 20 to 25 workers per day for up to 6 months. Construction of the ESJ Gen-Tie Project would require approximately 780,000 gallons of water and up to approximately 20,000 CY of earthwork (Burns and McDonnell 2009). Routine maintenance and inspections would be required for all project components and would be conducted by existing Sempra subsidiary company employees.

B.2.4 Other Wind Energy Projects

For purposes of this EIR/EIS, the project facilities of the following three wind projects including the turbines, collector system and substation, O&M facility, gen-tie line, access roads, and construction areas are assumed to be similar to that proposed for the Tule Wind Project.

Campo Wind Project

SDG&E proposes to construct and operate approximately 106 turbines capable of generating 160 MW of electricity on its reservation lands. The project would be located south of the Tule Wind Project and west of the Boulevard Substation on the Campo Indian Reservation. Construction of

the project would occur over a single phase. Turbines (approximately 450 feet tall from ground to tip of the fully extended turbine blade) would be located on available ridgelines on the reservation. In addition to the 160 MW of generating capacity proposed for this project, the Campo Tribe has requested that an additional 140 MW of generation be analyzed in the Bureau of Indian Affairs' (BIA's) National Environmental Policy Act (NEPA) review of the project for future development purposes. The proposed Invenergy and SDG&E Campo Wind Project would connect with the Boulevard Substation Rebuild component of the ECO Substation Project (Invenergy Wind California, LLC 2010).

Manzanita Wind Project

The Manzanita Tribe proposes a project capable of generating up to 57.5 MW, which could include up to 25 wind turbines depending on the turbine size selected. These wind turbines are proposed to be located on the same ridgeline as the existing Kumeyaay Wind facility. Turbines are proposed to be approximately 414 feet tall from ground to tip of the turbine blade fully extended. The Manzanita Wind Project would connect with the Boulevard Substation Rebuild component of the ECO Substation Project.

It is expected that the Campo and Manzanita wind energy projects would develop a switchyard for both facilities on non-tribal lands and a new 138 kV transmission line would be constructed along the existing right-of-way (ROW) of the 69 kV transmission corridor that currently connects to the existing Boulevard Substation. The new 138 kV transmission line would interconnect with the proposed Boulevard Substation Rebuild component of the ECO Substation Project.

Jordan Wind Project

The developers of the Jordan Wind Project have completed a preliminary wind energy assessment to construct and operate 40 2.3 MW turbines (total generating capacity of 92 MW) west of Boulevard in unincorporated San Diego County. The towers of the proposed wind turbines would be approximately 260 feet tall (height from ground to tip of fully extended blade would be approximately 430 feet). As proposed, construction of the project would occur between February and October 2013, and commercial operations are scheduled to begin in November 2013. The preferred point of interconnection for the Jordan Wind Project is the Boulevard Substation Rebuild component of the ECO Substation Project (Padoma Wind Power 2010).

B.3 ECO Substation Project

This section details the ECO Substation Project components and design specifications, describes the associated construction activities and procedures, explains the O&M procedures, and

presents a comprehensive listing of SDG&E's applicant proposed measures (APMs) to reduce potential impacts resulting from the ECO Substation Project.

B.3.1 Project Components

SDG&E proposes to construct the ECO Substation Project in southeastern San Diego County, near the unincorporated communities of Jacumba and Boulevard (Figures B-1, Regional Map, and B-2B, Vicinity/Overview Map, for the location of the proposed project). The ECO Substation project consists of four major components:

- A new 500 kV and 230/138 kV yard substation (the ECO Substation)
- SWPL loop-in to the proposed ECO Substation
- A new 13.3-mile 138 kV transmission line between the proposed ECO Substation and the rebuilt Boulevard Substation
- Boulevard Substation ~~rebuild~~Rebuild.

Table B-2 provides an overview and the general location of each project component. Figure B-2B, Vicinity/Overview Map, depicts the location of the major components.

B.3.1.1 ECO 500/230/138 kV Substation

Location

The proposed ECO Substation site is located approximately 0.5 mile south of Interstate 8 (I-8), 4 miles east of the community of Jacumba. The substation would be located on private land, just east of Old Highway 80, 0.5 mile west of the Imperial County border, and 0.5 mile north of the U.S.–Mexico border in southeastern San Diego County (Figures B-2B, Vicinity/Overview Map, and B-3, ECO Substation Temporary and Permanent Footprint). Privately owned, undeveloped land borders the northern, western, and southern sides of the ECO Substation site and undeveloped land managed by the BLM is located to the east.

Figure B-3, ECO Substation Temporary and Permanent Footprint, shows the fenced portion of the ECO Substation, which would encompass approximately 58 acres. The permanent impacts of the ECO Substation would be approximately 85.9 acres and would include the fenced substation, a 20-foot buffer around the perimeter of the substation yards, permanent slope and grading impacts, permanent access roads to the substation from Old Highway 80, and drainage facilities.

Table B-2
Summary of ECO Substation Project Components

Project Component	Location	Description	Project Impacts	
			Temporary Impacts (acres) ¹	Permanent Impacts (acres)
East County 500/230/138 kV Substation	Southeastern San Diego County, approximately 0.5 mile north of U.S.-Mexico border, 0.5 mile west of Imperial County border, and 4.0 miles east of the community of Jacumba.	Construction of a new substation (a 500 kV yard and a 230/138 kV yard) on privately owned, undeveloped land. The ECO Substation would include two separate fenced yards on 58 acres as well as a new access road. This project component would also include two retention basins and a buffer of approximately 20 feet around substation pad fencing.	26.15 (includes design/construction buffer)	85.9 (includes fenced substation yards, drainage facilities, buffer, and permanent cut-and-fill slopes)
SWPL Loop-In	Same general location as the ECO Substation 500 kV and 230/138 kV yards.	A short loop to connect the existing 500 kV SWPL into the new ECO Substation. Loop would begin at the existing SWPL and traverse approximately 1,500 feet south to the new ECO Substation. SWPL Loop-In would remove one existing tower and install four new steel towers with a maximum height of 125 feet. New permanent dirt access roads (20 feet wide and totalling approximately 1,700 feet long) would also be constructed.	0	1.74
138 kV Transmission Line	Generally between the ECO Substation and the Boulevard Substation. Line would parallel the existing SWPL south of Interstate 8 (I-8) and north of Old Highway 80 between the ECO Substation and milepost (MP) 5.7. Near MP 5.7, the line would cross Highway 80, travel parallel with the SWPL for 3.0 miles, and then turn north to the Boulevard Substation located south of Highway 80 and I-8.	The new 13.3-mile transmission line connecting the new ECO Substation and rebuilt Boulevard Substation would include 98 steel transmission poles and 9 wooden distribution poles. The final 440 feet of the transmission line would be installed in a concrete duct bank leading into the rebuilt Boulevard Substation. One steel cable riser pole, approximately 140 feet tall, would be installed. In addition, the new transmission line would require an approximate 100-foot-wide permanent ROW.	22.54	11.06

Table B-2 (Continued)

Project Component	Location	Description	Project Impacts	
			Temporary Impacts (acres) ¹	Permanent Impacts (acres)
Boulevard Substation Rebuild	South of I-8, south of Old Highway 80 within the unincorporated community of Boulevard in southeastern San Diego County. Rebuilt substation would be located east of the existing Boulevard Substation on privately owned land.	The rebuilt substation would provide 138 and 69 kV facilities to accommodate the proposed transmission line and gen-tie interconnections and 12 kV facilities to service the surrounding area. Once the rebuilt substation is constructed and energized, the existing substation would be demolished. One residence and eight structures on the rebuild site would be removed. In addition, project component would include the construction of a new 25-foot-wide, 190-foot-long asphalt-paved access road off of Old Highway 80.	0	3.2
Access Roads ²	On County of San Diego jurisdictional land, providing access to project facilities between the ECO Substation and the rebuilt Boulevard Substation.	New roads would be constructed to provide permanent access to project facilities and components, including the ECO Substation, SWPL Loop-In structures, 138 kV transmission line poles, and the rebuilt Boulevard Substation.	0	8.45

¹ See Section B.3.2.2 for further details regarding temporary workspace requirements.

² Permanent access road information is described in the subsequent Access Roads subsection.

Description

The proposed ECO Substation would include two separately fenced yards: a 500 and a 230/138 kV yard (Figures B-4, ECO Substation Site Plan, and B-5, ECO Substation Profile). The 500 kV yard would occupy approximately 32 acres (approximately 1,290 feet by 1,080 feet) and the 230/138 kV yard would occupy approximately 26 acres (approximately 1,060 feet by 1,080 feet). In addition to fencing surrounding the individual substation yards, a 10-foot-tall chain-link fence topped with barbed wire would enclose the substation (the entire 58-acre site). Figure B-5, ECO Substation Profile, shows the substation yards constructed at offset elevations.

Electrical facilities proposed at the substation yards include 500, 230, and 138 kV air-insulated electrical buses, steel support structures, transformers, capacitors, reactors, circuit breakers, disconnect switches, communication equipment, control equipment, and protective relays (SDG&E 2009). The initial arrangement of the ECO Substation would consist of:

- Two 500 kV bays in a ring bus configuration
- One 500/230 kV transformer bank (three single-phase units with one operation spare)
- Three 230 kV bays in a breaker-and-a-half bus configuration
- One 230 kV shunt capacitor
- One 230/138 kV transformer bank
- Two 138 kV bays in a double-bus/double-breaker bus configuration (four bay structures)
- One 12 kV, 180-megavolt ampere reactive (MVAR) shunt reactor bank
- One microwave communication tower.

The substation would be designed so that it would ultimately be expanded to the following arrangement:

- Five 500 kV bays in a breaker-and-a-half bus configuration
- Nine 230 kV bays in a breaker-and-a-half bus configuration
- Nine 138 kV bays in a double-bus/double-breaker bus configuration
- Four 500/230 kV, 1,120 megavolt ampere (MVA) transformer banks with two single-phase operational spares
- Three 230/138 kV, 392 MVA transformer banks
- One or more 500 kV series capacitors
- Two 230 kV, 63 MVAR shunt capacitors

- Four 12 kV, 180 MVAR shunt reactor banks
- One 230 kV static MVAR compensator.

Other facilities associated with the ECO Substation would include a new access road, drainage facilities, metering, supervisory control and data acquisition (SCADA), security, communications equipment, two single-story relay/control buildings, a single-story storage building, and a fire suppression system with associated hydrants and an approximately 120,000-gallon water tank (15 feet high and 30 feet wide). The 120,000-gallon water tank would provide water for fire suppression purposes and would also be used for landscape irrigation. Two stationary generators (a 200- and a 100-kilowatt (kW) unit used as a backup to the station lights and power transformers) and a substation ground grid (in accordance with applicable safety guidelines) would also be installed. Generators would be used only during emergencies and would be in operation for no more than 50 hours annually.

Figure B-3, ECO Substation Temporary and Permanent Footprint, shows the northernmost gen-tie steel lattice tower/steel monopole of the proposed ESJ Gen-Tie Project (discussed in Section B.5) would also be located within the fenced boundary of the ECO Substation.

The tallest structures in the substation would be the steel lattice tower/steel monopole associated with the proposed ESJ Gen-Tie Project along with the 500 kV line and transformer dead-end structures and new communication tower. The maximum height for the steel lattice tower and steel monopole associated with the ESJ Gen-Tie Project would be 150 and 170 feet, respectively. The maximum height for the 500 kV structures and communication tower would be approximately 135 feet.

Drainage of the site would be facilitated through the construction of two retention ponds. Figures B-3, ECO Substation Temporary and Permanent Impacts, and B-4, ECO Substation Site Plan, show an approximate 1.2-acre retention basin that would be constructed in the area bounded to the east by the ECO Substation main access road and to the south by the 230/138 kV substation yard pad for on-site storage of water during construction. After construction, the basin would remain permanently for stormwater retention for the 500 kV yard. A second retention basin, approximately 1.9 acres in size, would be constructed along the western side (outside of the fenced boundary) of the 230/138 kV yard for collection of drainage from the 230/138 kV yard. Both retention ponds will be lined to store construction water. Once construction is complete, the lining will either be removed or punctured to allow water seepage into the ground.

Figures B-3, ECO Substation Temporary and Permanent Footprint, and B-4, ECO Substation Site Plan, show an approximate 2,900-foot-long main access road that would be constructed from Old Highway 80 southeast to the ECO Substation. The access road would be paved and

would extend off of Old Highway 80 and run along the north side of the 500 and 230/138 kV yard pads. Four asphalt-paved driveways, approximately 100 feet in length, would be constructed off the main access road and would provide access to the four gated entrances (two entrances per substation yard) of the substation. All entrances would be locked and monitored remotely to limit access. The access roads would be approximately 30 feet wide and would cumulatively require approximately 2.2 acres of land.

Lighting at the substation would be provided by 50 300-watt tungsten-quartz lamps placed near major electrical equipment. Yard lights would normally be turned off and would only be used during nighttime operations and maintenance for security and safety. In addition to yard lights, approximately 14 100-watt yellow floodlights would be mounted near the substation gates and building entrances to allow for nighttime emergency repair and routine maintenance access. All substation lighting would be oriented downward to minimize glare onto surrounding property and habitat.

B.3.1.2 Southwest Powerlink (SWPL) Loop-In

Location

The SWPL Loop-In would be constructed in the same general location as the ECO Substation (Figures B-2B, Vicinity/Overview Map, and B-3, ECO Substation Temporary and Permanent Impacts). The SWPL Loop-In would consist of a short loop to connect the existing 500 kV SWPL transmission line into the new substation. The loop-in would begin along the existing SWPL ROW northeast of the ECO Substation 500 kV yard, traverse south for approximately 1,200 feet, then turn west for 250 feet, and enter at the east side of the ECO Substation 500 kV yard. The looping of the existing 500 kV SWPL transmission line into the ECO Substation would result in permanent impacts to approximately 1.74 acres of land.

Description

Construction of the SWPL Loop-In would require the removal of an existing 125-foot-high tower and installation of four new steel lattice structures to be located east of the ECO Substation 500 kV yard fence (Figure B-3, ECO Substation Temporary and Permanent Footprint, for location of SWPL Loop-In structures). The anticipated maximum height of the new steel lattice structures would be approximately 125 feet. The distance from the ground to the lowest conductor installed on the SWPL Loop-In structures would be at least 35 feet and the span lengths between the transmission structures would be approximately 1,200 feet. Figure B-6, ECO Substation Project SWPL Loop-In Structure Typical Drawing, provides a typical drawing of the lattice structures to be installed.

In order to provide access to the new SWPL Loop-In structures, new permanent access roads would be constructed. These roads (approximately 20 feet wide and 1,700 feet long) would be constructed from the existing SWPL ROW to the new SWPL Loop-In structures (Figure B-3, ECO Substation Temporary and Permanent Footprint). New access roads would require approximately 0.79 acre of land.

B.3.1.3 Overhead 138 kV Transmission Line

Location

Figures B-2B, Vicinity/Overview Map, and B-7, B-8, and B-9B (ECO Substation Overhead 138 kV Transmission Line), show the approximate 13.3-mile-long overhead 138 kV transmission line that would be constructed from the proposed ECO Substation to the rebuilt Boulevard Substation located south of Old Highway 80 within the unincorporated community of Boulevard in southeastern San Diego County. The proposed line would travel west out of the 230/138 kV yard of the ECO Substation for 300 feet and then turn north towards the existing SWPL. At a point nearly 250 feet south of the SWPL, the 138 kV transmission line would then travel west, parallel to the SWPL, for approximately 5.7 miles (this segment of the line would traverse BLM-administered land for approximately 1.5 miles). At this point, the line would cross under the SWPL and then continue parallel for another 3.2 miles on the north side of the SWPL until it intersects with an existing dirt access road. From this location, the transmission line would turn to the northwest for approximately 750 feet before turning and continuing north for approximately 1.5 miles. The line would then turn east for approximately 0.6 mile, north for approximately 0.3 mile, and northwest for approximately 0.3 mile until it crosses over Tule Jim Lane. The line would then travel north along the west side of Tule Jim Lane for approximately 1.3 miles until it crosses Eady Lane, at which point the line would be placed underground. At Eady Lane, the line would be placed underground within a 138 kV duct bank and would turn northeast for approximately 0.1 mile until it entered the rebuilt Boulevard Substation. Approximately 9 miles of the new 138 kV transmission line would be parallel to the SWPL and would be adjacent to SDG&E's existing easements. This area is mostly privately owned, undeveloped rural land under County of San Diego jurisdiction.

The new 13.3-mile, 138 kV transmission line would require a 100-foot-wide permanent ROW and 2.6 miles of new 15-foot-wide spur roads (5.25 acres) for access to transmission line structures. Total permanent impacts for the proposed 138 kV transmission line (not including access roads) would be approximately 11.06 acres (includes area around transmission poles). The total ROW land requirement would be approximately 161 acres.

Description

The new 13.3-mile-long, 138 kV transmission line would be supported by 98 steel transmission poles (Figures B-7, B-8, and B-9B, ECO Substation Project Overhead 138 kV Transmission Line). Nine wooden distribution poles would also be installed along the route to replace existing Circuit 445 distribution poles. The distribution line would be collocated on the new 138 kV transmission line structures south of Boulevard near the intersection of Jewel Valley Road and Tule Jim Lane. Figure B-10, ECO Substation Project 138 kV Steel Pole Typical Drawing, shows the 138 kV steel poles, which would have six cross-arms and an extended pole top to accommodate a fiber-optic ground wire attachment for lightning protection and critical internal communications (the fiber-optic line will not be used for external communications). The distance of one cross-arm would be approximately 16 feet with a V-string single-circuit configuration. The height of the steel pole would vary by location up to a maximum height of 150 feet. The tallest 138 kV structure, which would be the steel cable riser pole, would be approximately 150 feet tall. The vertical distance between the cross-arms on the steel case riser would be 20 feet. The distance between the ground and the lowest conductor would be at least 30 feet and the distance between conductors would be 18 feet horizontally and 12 feet vertically. Although span lengths between poles would be dependent on terrain, lengths would generally be between 400 and 800 feet. Components used to construct the proposed 138 kV transmission line would all feature non-reflective surfaces. For instance, the insulators would be constructed of gray polymer, the conductors would be made from aluminum-wrapped steel, and the transmission poles and associated hardware would be composed of galvanized steel.

The replacement wood distribution poles would have four cross-arms and would be approximately 38.5 feet tall. A typical drawing of the replacement wood distribution poles is provided as Figure B-11, ECO Substation Project Typical Wooden Distribution Pole.

The final approximate 440 feet of the 13.3-mile-long 138 kV transmission line would be installed underground in a concrete duct bank that would terminate at the rebuilt Boulevard Substation. The approximately 38-inch-wide, 36-inch-tall duct bank would contain nine 6-inch diameter conduits. One steel cable riser pole, which would be approximately 150 feet tall, would be installed at the end of the overhead segment of the transmission line to connect the overhead conductors to the underground substation getaways. The proposed conductor within the underground concrete duct bank located between the cable riser pole and the rebuilt Boulevard Substation would be a 2,500 thousand circular mil (kcmil) copper cross-linked polyethylene cable. Typical drawings of the steel cable riser pole and the underground 138 kV duct bank are provided as Figures B-12, ECO Substation Project Steel Cable Riser Pole Typical Drawing, and B-13, ECO Substation Project Underground 138 kV Concrete Duct Bank Typical Drawing.

Access roads would be constructed to most steel pole locations in order to facilitate transmission line installation and to allow for inspection and maintenance. All access roads to be built would be spur roads constructed off of existing dirt roads. Spur roads would vary in length of between 20 to 250 feet and would be approximately 15 feet wide. A total of approximately 2.6 miles of spur roads would be constructed, requiring 5.25 acres of land. Access roads to transmission pole locations are identified in Figures B-7 through B-9B (ECO Substation Project Overhead 138 kV Transmission Line).

B.3.1.4 Boulevard Substation Rebuild

Location

The existing Boulevard Substation is located south of I-8 within the unincorporated community of Boulevard, approximately 9 miles northwest of the proposed ECO Substation Site (Figure B-2B, Vicinity/Overview Map). Old Highway 80 is located just north of the site. As proposed, the rebuilt Boulevard Substation would be located immediately east of the existing substation on a 8.5-acre parcel recently acquired by SDG&E (Figures B-14B, ECO Substation Project Boulevard Substation Temporary and Permanent Footprint, and B-15B, ECO Substation Project Boulevard Substation Rebuild). Eight existing structures (one residence, a barn, a garage and five other smaller structures) currently located on the 8.5-acre parcel would be removed to rebuild the substation. The rebuilt substation would encompass approximately 2 acres. The 3.2 acres of the 8.5-acre parcel is considered to be permanently impacted, and this area would include the fenced substation, a 10-foot buffer around the perimeter of the substation, permanent slope and grading impacts, and permanent access to the substation from Old Highway 80.

Description

The fenced area of the approximate 2-acre rebuilt substation would include 138, 69, and 12 kV facilities to accommodate the proposed 138 kV transmission line as well as the potential for up to four gen-ties. In addition, the rebuilt substation would provide 12 kV service to the surrounding area via an existing 69 kV transmission line. In order to connect the existing 69 kV transmission line (TL 6931) to the rebuilt Boulevard Substation, two new direct embedded steel poles (approximately 85 feet tall) would be installed to the southwest of the rebuilt substation site. Once the rebuilt Boulevard Substation is constructed and energized, the existing substation would be dismantled and removed.

Electrical facilities installed at the rebuilt Boulevard Substation would include 138, 69, and 12 kV air-insulated buses, transformers, circuit breakers, disconnect switches, communication equipment, and protective relays. The initial arrangement of the rebuilt substation would consist of:

- One 138 kV low-profile radial bus with three line positions, two transformer positions, one bus-tie position, and one future capacitor position
- One 138 kV tie-line to the ECO Substation
- Two ISO-proposed 138 kV generator ties
- One 138/69 kV transformer
- One 138/12 kV transformer
- Two bays of 69 kV standard-profile switch racks with four line positions and one transformer position
- One 69 kV tie-line to the SDG&E Crestwood Substation
- One quarter section 12 kV switchgear
- One 12 kV capacitor
- One control shelter.

The substation would be designed so that the ultimate configuration would include the following:

- Two sections of 138 kV low-profile radial buses with six line positions, three transformer positions, one capacitor position, and a bus-tie
- One 138/69 kV transformer
- Two 138/12 kV transformers
- Two bays of 69 kV standard-profile switch racks with four line positions and one transformer position
- Two quarter section 12 kV switchgears
- Four 12 kV capacitors
- One control shelter.

The ultimate layout of the rebuilt Boulevard Substation is shown on Figure B-15B, ECO Substation Project Boulevard Substation Rebuild. A profile drawing of the Boulevard Substation is provided on Figure B-16, ECO Substation Project Boulevard Substation Profile.

The tallest structure in the rebuilt Boulevard Substation would be the transformer A-frame structure. As shown on Figure B-16, ECO Substation Project Boulevard Substation Profile the maximum height for the A-frame structures would be 39 feet.

Access to the rebuilt Boulevard Substation would be provided by a total of approximately 0.2 acres of new, permanent, 25-foot-wide asphalt-paved access roads. An approximate 190-foot-

long new access road would be constructed off of and provide access via Old Highway 80, and would terminate at the main access gate located along the northwestern edge of the rebuilt substation. A new secondary access road would also provide access to the facility via an approximate 160-foot-long paved spur road off the main access road that would terminate at the secondary access gate, located approximately 140 feet to the east of the main access gate. Access roads and gates are shown on Figure B-15B, ECO Substation Project Boulevard Substation Rebuild.

B.3.2 ECO Substation Project Construction

This section presents an overview of the construction schedule and methods typically used for construction of a new substation, installation of overhead transmission lines, construction of new pole structures, demolition of an existing substation, and undergrounding of a transmission line.

B.3.2.1 Construction Schedule

Construction of the proposed ECO Substation Project is anticipated to require 2 years to complete. Table B-3, ECO Substation Project Proposed Construction Schedule, provides SDG&E’s proposed schedule for the project, as defined in its Permit to Construct (PTC) application. While the schedule would be modified to begin after California Public Utilities Commission (CPUC) approval, this table illustrates the approximate length of each construction phase.

Table B-3
ECO Substation Project Proposed Construction Schedule

Project Component	Activity	Approximate Duration (Months)
ECO Substation 500 kV and 230/138 kV Yards	Site Development	8
	Below-Grade Construction	8
	Above-Grade Construction	8
	Communication Equipment	1
	Testing and Commissioning	2
	Energization	0.5
SWPL Loop-In	Access Roads	0.5
	Install Foundations	1
	Tower Installation and Conductor Stringing	0.5
138 kV Transmissions Line	Access Roads	3
	Pole Foundation Installation	4
	Pole Installation	3
	Conductor Stringing and Sagging	3
Boulevard Substation Rebuild	Site Development	4
	Below-Grade Construction	3
	Above-Grade Construction	3

Table B-3 (Continued)

Project Component	Activity	Approximate Duration (Months)
	Testing and Commissioning	2
	Energization	0.5
	Existing Substation Demolition	2

Source: SDG&E 2009.

SDG&E anticipates that construction activities would be limited to no more than 12 hours per day, Monday through Saturday. Construction activities may occasionally be required at night or on weekends to minimize disturbances to the construction schedule, to facilitate cutover work, or to comply with adjacent property owners or agencies, such as the California Independent System Operator (CAISO). If construction does occur outside of the hours permitted by the County of San Diego, SDG&E would follow established protocol and provide advanced notice to property owners within 300 feet of planned activities. The advanced notice would include the anticipated start and completion dates of construction and the hours of construction.

B.3.2.2 ECO Substation Construction Activities and Methods

In order to facilitate construction, temporary workspace would be required for nearly all project components. Table B-2 provides the anticipated workspace requirements. Figure B-3, ECO Substation Temporary and Permanent Footprint, illustrates the anticipate staging or workspace areas for the ECO Substation and SWPL Loop-In and Figures B-7, B-8, and B-9B (ECO Substation Overhead 138 kV Transmission Line) show the anticipated work spaces for the overhead 138 kV transmission line. As illustrated in Table B-2, temporary workspace would not be required for construction of the Boulevard Substation.

ECO 500/230/138 kV Substation

The ECO 500/230/138 kV Substation site would be used for the staging of substation materials and construction equipment (the primary staging area for the entire project would be located within the ECO Substation permanent footprint).

Site Preparation

Two staging areas, both approximately 250 feet by 175 feet (1 acre) and located north of the ECO Substation 500 kV yard, would be cleared and graded. These areas would be used for the staging of materials and for siting of construction offices (Figure B-17, ECO Substation and SWPL Loop-In Temporary Workspace Areas, for location of staging areas). A design/construction buffer of approximately 100 to 150 feet around the substation (approximately 23.6 acres) would also be utilized during construction. A temporary tap to an existing distribution line to provide power to the ECO Substation staging areas during

construction would require a temporary ROW of approximately 2,000 feet by 12 feet (0.55 acre). The temporary distribution line tap would require the installation of up to eight wooden distribution poles within the temporary ROW. Since the temporary tap would take approximately 2 months to complete, two propane generators would be placed at the staging areas (one at each of the proposed staging yards) and would be utilized until the temporary tap is complete. As shown in Table B-2, total temporary workspace requirements associated with the ECO 500/230/138 kV Substation would be approximately 26.15 acres.

Construction of the ECO Substation yards would require the permanent removal of nearly 88 acres of mixed desert scrub and juniper woodland. No trees would be removed during grading. Construction activities would commence once access to the site has been provided. As described in Section B.3.1.1, SDG&E would construct an approximately 2,900-foot-long main access road (using Class II base material) off of Old Highway 80 and four 100-foot long paved asphalt substation driveways. Once access to the substation has been constructed, major site grading would follow. Approximately 1.1 million cubic yards (CY) of cut-and-fill material would be required to develop the pads and access roads. Depending on the characteristics of the site soil, import Class II base may be required to provide a 4- to 12-inch surface cap for the substation yards. On-site material would be reused to the extent possible. Site grading would require the use of bulldozers and scrapers in order to cut and fill native soil to the proposed pad elevations.

Development of the ECO Substation could require as much as 140,000 CY of imported fill. This amount would require 10,000 haul truckloads, or an average of approximately 60 truck trips per day for an estimated 8-month period. All fill would be hauled from the Imperial Valley. In addition, approximately 200 additional trips are anticipated for delivery of materials and equipment for the duration of the construction.

Site preparation would also include construction of drainage components, including above-grade concrete drainage swales, underground drains, and concrete catch basins to capture and direct stormwater flow across the site to one of two retention basins. A drainage plan identifying the location and size of all drainage components would be developed by SDG&E. The drainage plan would be implemented to minimize surface water and erosion impacts.

Foundation Construction

Construction of the substation equipment foundations (consisting of drilled pier, mat, and pad type foundations) and the grounding grid would begin once the site has been cleared and graded. Backhoes and drill rigs would be used to excavate foundations. Forms, reinforcing steel, and concrete would then be installed in order to build the foundations.

Aboveground Equipment Installation

Once the foundation has been constructed, installation of aboveground equipment (including placement of major equipment on their respective foundations or structures, anchoring their final position, and wiring of the equipment controls and protection devices) would begin. This work would be accomplished by delivering equipment to the site on flatbed trucks and lifting it into place using cranes. The distribution line tap and associated ROW would be abandoned once power transformers are installed.

At this time, the SWPL Loop-In would be brought in and out of the ECO Substation and connected to buses via circuit breakers. For connection to renewable energy sources and the Boulevard Substation, the conductors would be connected to the buses by a disconnect switch and circuit breakers.

Post-Construction Restoration

Following construction, all areas temporarily disturbed by construction of the ECO Substation would be restored to preconstruction conditions (to the extent practicable). Post-construction restoration is detailed in SDG&E's Landscape Concept Plan for the ECO Substation and Boulevard Substation (SDG&E 2009, included within the PEA Aesthetics section).

SWPL Loop-In

Construction of the SWPL Loop-In would require the use of four work areas generally located around the proposed SWPL Loop-In structures. The location of the work areas is depicted on Figure B-17, ECO Substation and SWPL Loop-In Temporary Workspace Areas.

Site Preparation

Construction would require the clearance of approximately 1.74 acres of undeveloped land in order to install the SWPL Loop-In structures and conductor and to allow for tie-in to the existing 500 kV SWPL line. Clearing would be facilitated using mowers and bulldozers. Four work areas (one at each of the proposed SWPL Loop-In transmission structure locations), each approximately 75 feet by 35 feet, would be required. An additional 5,000 square feet of temporary disturbance (attributed to driving, placement of vehicles, and general construction activities) would be anticipated for the installation of each steel lattice structure.

Installation of the SWPL Loop-In would require four pull sites. While two of the proposed pull sites would be located within the ECO Substation footprint, the remaining two would be located within the temporary SWPL Loop-In work areas described above. The location of these pull sites is depicted on Figure B-17, ECO Substation and SWPL Loop-In Temporary Workspace Areas. The two pull sites located within the SWPL Loop-In work areas would be approximately 250

feet by 130 feet. Pull sites would be graded and would be spaced approximately 1,200 feet apart. The four SWPL temporary work areas identified above would be used as permanent maintenance pads in accordance with SDG&E design standards (SDG&E 2010). Therefore, the 1.74 acres attributed to SWPL work areas are considered permanent impacts (Table B-2).

Foundation Construction

Structure foundations would be drilled concrete piers and the foundation process would begin with the boring of four holes for each structure. Each hole would be bored using truck-mounted excavators with various diameter augers to match diameter and depth requirements for the foundation sizes. If solid rock is encountered during boring, additional equipment, including rock hauling equipment, blasting equipment, or the use of a rock anchoring or mini-pile system, would be required. A rock anchoring or mini-pile system would be used where access to the site is difficult or in locations where blasting or rock excavation could damage adjacent structures.

Each foundation hole would generally be 3 to 5 feet in diameter and 10 to 15 feet deep and would displace approximately 29 CY of soil. Depth and width characteristics would be dependent on site conditions. Following excavation of the foundation hole, reinforcing steel would be installed and concrete would be poured. Each structure would require approximately 27 CY of concrete. Concrete would be delivered directly to the structure locations in 10 CY capacity concrete trucks. If access is limited, concrete may be pumped from several hundred feet away from the structure location. Once completed, each foundation would extend approximately 2 feet above ground surface.

Aboveground Equipment Installation

Structure segments would be delivered on flatbed trucks to each location and assembled on site. The structure segments would be bolted together and assembly would be facilitated through the use of a small truck-mounted crane. Once assembled, the structure segments would be hoisted onto the foundation and then bolted together by use of a larger crane or helicopter. Helicopter models typically used during structure assembly include a Sikorsky S-64 Skycrane/Aircrane or a Sikorsky S-58T.

Conductor Installation

Similar procedures would be used during conductor installation associated with the SWPL Loop-In and the 138 kV transmission line. In order to ensure that the SWPL can be taken out of service and power can be redistributed, SDG&E would coordinate with CAISO to obtain all the necessary line clearances prior to beginning conductor installation. Conductor stringing operations would be facilitated with the installation of sheaves or “rollers” on the structure cross-arms during structure installation using helicopters, such as a Bell Long Ranger, Bell Jet Ranger,

MD 500, or Bell UH-1 Huey, or aerial manlifts (bucket-trucks). The sheaves would allow the conductor to be pulled through each structure until the entire line is ready to be pulled up to the final tension position. Following sheave installation, a sock line rope (a small cable used to pull the conductor) would be pulled onto the sheaves using a helicopter that would travel from structure to structure along the ROW. Once in place, the rope would be attached to a steel cable and pulled back through the sheaves. The conductor would then be attached to the cable and pulled back through the sheaves using conventional tractor trailer pulling equipment located at pull and tension sites.

After the conductor is pulled into place, the sags between the structures would be adjusted to a pre-calculated level and the line would be installed with a minimum ground clearance of 35 feet. The conductor would then be clipped into the end of each insulator, the sheaves would be removed, and vibration dampers and other accessories would be installed. A typical drawing of the aboveground conductor installation procedure is provided as Figure B-18, ECO Substation Project Aboveground Conductor Installation Procedure Typical Drawing.

Post-Construction Restoration

Six 75-foot by 35-foot working zones around all structures would be cleared of shrubs and other obstructions for inspection and maintenance purposes. Following the completion of the SWPL Loop-In, all other temporarily disturbed areas around each structure and areas used for conductor pulling and tensioning, staging, and structure installation would be restored to preconstruction conditions, to the extent practicable. Restoration would include grading to original contours and reseeding.

138 kV Transmission Line

An existing staging area, located adjacent to the SWPL and north of proposed 138 kV transmission line steel pole (SP) 88, would be utilized as a staging area during construction of the 138 kV transmission line. The existing staging area is approximately 170 feet by 100 feet (0.40 acre) and is depicted in Figure B-8, ECO Substation Overhead 138 kV Transmission Line.

Site Preparation

Construction of the overhead line would begin with the construction of new, unpaved access roads to the new transmission line steel pole structures. These roads would be graded level and generally 15 feet wide for straight sections and up to 20 feet wide at curves to allow the safe access of construction equipment and vehicles.

According to SDG&E, approximately 98 steel poles and 9 wooden distribution poles would be required to support the new 138 kV transmission line. Installation of each pole would require a cleared and graded work area of approximately 70 feet by 70 feet (0.11 acre) to accommodate

construction equipment and activities. Additional area may be required around each pole location to accommodate operation of vehicles and equipment and would measure 115 feet by 115 feet (including the approximately 7080-foot by 7060-foot work area). Each wooden distribution pole location would require a work area of approximately 30 feet by 30 feet (0.02 acre). The 98-steel-pole and 9-wooden-distribution-pole temporary work areas would be used as permanent maintenance pads in accordance with SDG&E design standards (SDG&E 2010). If solid rock is encountered during structure installation activities, then additional work area would likely be required in order to accommodate necessary equipment. No trees would be removed; however, several trees located near the Boulevard Substation would require trimming.

Foundation Construction

Installation of direct-bury steel poles would require the excavation of holes approximately 6 feet in diameter and 13 to 20 feet deep, depending on the type and height of the pole. Holes would be drilled using a truck-mounted auger or similar equipment, and each hole would displace approximately 9 CY of soil. New poles would be delivered to each location and would be placed using helicopters and/or cranes. The annular space between poles and holes would then be backfilled with concrete and any remaining excavated material would be placed around the holes or spread onto access roads and adjacent areas.

Engineered steel poles would be drilled on pier foundations. Installation would require the excavation of holes approximately 7 to 8 feet in diameter and 20 to 30 feet deep (approximately 54 CY of soil), depending on the type and height of the pole. Holes would be drilled using a truck-mounted auger or similar equipment. Steel cages and anchor bolt cages would be set in the open hole for reinforcement, and approximately 50 CY of concrete would be poured to a level approximately 2 feet above grade. Any remaining excavated material would be placed around the holes or spread onto access roads and adjacent areas.

Underground Service Alert would be notified by SDG&E at least 48 hours in advance of ground-disturbing activities. Exploratory excavations would be conducted by SDG&E to verify the locations of existing facilities in the project area.

Aboveground Equipment Installation

Prior to stringing the new overhead 138 kV line, approximately 10 temporary clearance structures consisting of vertical wood poles with cross-arms would be installed at road crossings and crossings of energized electric and communication lines. These structures would prevent the conductors from sagging onto roadways or other lines during the conductor installation. Bucket trucks may be used for clearance structures in some cases. Each clearance structure would require an approximately 30-foot by 30-foot (0.02 acre) temporary workspace area.

Conductor and fiber-optic ground wire stringing would follow the same process as described above for the SWPL Loop-In.

In some cases, such as when the conductor is slightly damaged during stringing operations or if the conductor is not long enough and needs to be joined to another segment, sleeves or slices may be installed on the transmission line. During full tension splices, the two ends of the conductor are connected with the use of heavy-duty vices, or alternatively, a small engineered implosive charge is wrapped around a specially designed metallic sleeve creating a controlled implosive compression connecting the two conductors.

Installation of the new 138 kV conductor would require 12 pull sites along the transmission line route. Pull site locations are illustrated in Figures B-7, B-8, and B-9B (ECO Substation Overhead 138 kV Transmission Line). The 12 pull sites do not include the pull sites within the ECO Substation and the Boulevard Substation footprint or the four pull sites along existing roadways along the transmission line alignment. Generally, pull sites would be approximately 100 feet by 150 feet and would be required where 138 kV angle structures are located. The sites would be needed to load the tractors and trailers with reels of conductors and the trucks with tensioning equipment. Each pull and tension site would require clearing an area of approximately 0.34 acre.

After the conductor has been pulled into place, the sag between the structures would be adjusted to a pre-calculated level and the line would then be installed with a minimum ground clearance of 30 feet. The conductor would then be attached to the end of each insulator, the sheaves would be removed, and the vibration dampers and other accessories would be installed.

Helicopter activities would be staged out of the Jacumba Airport when possible, and staging areas and access roads along the existing SWPL ROW would be utilized as potential landing zones. Helicopter landing areas would generally be located at least 1 mile away from residences and other sensitive land uses. As shown in Figures B-7, B-8, and B-9B (ECO Substation Overhead 138 kV Transmission Line), three fly yards (approximately 500 feet by 500 feet each) are anticipated for use during construction for helicopter take-offs and landings and as refueling areas. Pole storage and assembly would be located along the proposed 138 kV transmission line alignment route.

Underground Duct Package and Cable Installation

The proposed 138 kV transmission line would enter the Boulevard Substation via an underground duct package and intercept the overhead lines via a steel cable riser pole (SP-1). The underground facilities would be installed in a duct bank composed of nine 6-inch-diameter polyvinylchloride (PVC) conduits placed in concrete (Figure B-13, ECO Substation Project Underground 138 kV Concrete Duct Bank Typical Drawing).

The duct bank trench would be excavated using a backhoe and the depth of the trench would be determined by localized topography and potential conflicts, but is expected to be approximately 2.5 feet wide and 6 feet deep. Once installed, the depth from grade to the top of the concrete duct package would be approximately 2.5 feet deep and the depth from grade to the top of the conduit in the duct package would be approximately 3 feet. The trench alignment would proceed to the riser pole that provides the necessary structure to mechanically terminate the overhead conductors and support the underground cable terminators required for the underground cable.

The trench for the duct bank would be approximately 440 feet long. Installation of the underground duct bank would require an approximately 450-foot by 50-foot (0.52-acre) temporary workspace area and would result in the excavation of approximately 310 CY. After installation of the concrete duct bank, approximately 155 CY of this material would be used to backfill the trench (no engineered backfill is anticipated to be required) and the remainder of the excavated material would be spread across the ROW or access roads, incorporated into the substation grading or berms, or disposed of at an appropriate facility. Based on the Phase I Environmental Site Assessment, contaminated soils are not expected to be encountered during subsurface activities.

Once trenching activities for the underground 138 kV duct bank have been completed, the PVC cable conduits would be installed and concrete would be poured around the conduits to form the duct banks. Upon completion of the duct bank, cables would be installed by being pulled into the duct bank and terminating at the riser pole where the line converts to an overhead configuration.

After the conductor has been installed, the ground surface would be restored to near preconstruction conditions, and vegetation would be replanted as appropriate.

Distribution Line Relocation

The existing 12 kV distribution circuit 445 would be removed from its existing location and collocated with the 138 kV transmission line facilities. Construction activities would involve the removal of the existing wood distribution poles, placement of some of the existing distribution circuit equipment on the newly installed wood distribution poles, and replacement of the existing distribution conductor (#6 bare strand, copper, #2 ACSR, and #2 Alumoweld-aluminum conductor) with a 636 kcmil Aluminum Clad Steel Reinforced (ACSR/AW) conductor. Pole installation work would be accomplished with the same equipment used for the installation of 138 kV transmission line poles. The holes from which the old wooden distribution poles are removed would be backfilled with native material from the excavations for the new 138 kV transmission steel poles. Old wooden distribution poles would be removed from the site by a crane and flatbed trucks and then recycled or disposed of at an authorized facility. All areas

temporarily disturbed around each structure would be restored to preconstruction conditions to the extent practicable following installation of the new transmission line.

Boulevard Substation Rebuild

The disturbed, recently SDG&E-acquired 8.5-acre parcel on which the rebuilt Boulevard Substation would be located would be utilized as the staging area for construction of the substation. This area would require minor clearing and grading (Figures B-9B, ECO Substation Overhead 138 kV Transmission Line, and B-14B, ECO Substation Project Boulevard Substation Temporary and Permanent Footprint).

Demolition of Existing Boulevard Substation

Prior to demolition activities, the soil, conduit, equipment, and steel structures currently located at the existing Boulevard Substation would be tested for environmental hazards, including oil, lead-based paint, and asbestos prior to demolition of the existing Boulevard Substation. All identified hazardous materials would be abated prior to or during the demolition process. Demolition activities would include disconnecting and removing all substation equipment including transformers, breakers, regulators, disconnect switches, fuses, the station light and power transformer, control cabinets, and the DC cabinet. Also, all of the on-site structural steel including the 69 kV and 12 kV switch racks, equipment support structures, and substation fences and gates removed during demolition activities would be recycled (all dismantled equipment would be tested in accordance with federal, state, and local standards to determine the appropriate recycle, reuse, or disposal alternatives). Once all aboveground structures have been removed, demolition and removal of all below-grade facilities (foundation pads, piers, and direct-buried control cable) would begin. Oil drained from on-site equipment would be processed in accordance with SDG&E standard procedures.

Site Preparation, Foundation Construction, and Aboveground Equipment Installation

The removal of three mature coast live oak trees and trimming of one oak tree may be required in order to rebuild the Boulevard Substation and maintain the required clearance under CPUC General Order 95. The trees would be removed with earth-moving equipment, such as bulldozers and excavators, and tree-trimming activities would be conducted with hand tools, such as chainsaws. Except for the four oak trees and Jacumba milk-vetch, no other native plant species would be removed based on 2009 field surveys.

Access, pad construction, and equipment installation would be accomplished in a similar manner to the procedures previously described for the ECO Substation. Once site development activities, below-grade construction, and above-grade construction have been completed, all temporarily disturbed areas would be re-contoured and reseeded, as appropriate. The grading

would be based on a grading plan emphasizing balanced cut and fill to the extent possible. Depending on the characteristics of the site soil, up to 4,000 CY of Class II base may be imported and up to 24,000 CY of material may be removed from the site; however, as much export material as possible would be used on site to recontour grades and provide visual buffers. Some days would have more truck trips than others, but, in general, no more than 30 truck trips per day for an estimated 3 months would be required to complete the substation rebuild. In addition, an average of six truck trips per day are expected for delivery of materials and equipment for the duration of construction.

Lastly, the existing 69 kV transmission line (TL 6931) would be rerouted into the rebuilt Boulevard Substation. Rerouting would require the installation of two direct embedded steel poles, approximately 85 feet in height, and associated guying. These poles would be located west of the substation rebuild site.

B.3.2.3 Construction Personnel and Equipment

According to the preliminary construction schedule proposed by SDG&E, up to approximately 89 individuals would be needed each day over a 1-month period of peak construction activity during below-grade construction and communication equipment installation at the ECO Substation site, construction of access roads for the 138 kV transmission line, and site development for the Boulevard Substation rebuild. The construction of all three components are expected to overlap for 1 month. Table B-4, ECO Substation Project Peak Construction Personnel, presents the peak construction personnel anticipated for the ECO Substation Project.

Table B-5, ECO Substation Project Typical Construction Equipment by Activity, presents the equipment requirements of the ECO Substation Project, including the anticipated duration of equipment use.

Project construction would involve the use of a wide variety of heavy construction equipment on site. The majority of equipment and vehicles would be associated with the intensive earthwork, structural, and paving phases of construction. Large construction equipment, including earthmovers, cranes, rollers, fuelers, concrete mixers, and delivery trucks, would be used during the construction phase of the project. During peak construction, approximately 50 to 60 vehicle trips per day for construction crews and equipment/material deliveries would occur. Access to and from the construction site would primarily occur via the Carrizo Gorge Road exit (Exit 73) off I-8 and dirt access roads off Old Highway 80.

Table B-4
ECO Substation Project Peak Construction Personnel

Project Component	Position	Number of Personnel Required
ECO 500/230/138 kV Substation	Superintendent	1
	Foremen	3
	Grade Checkers	4
	Operators	25
	Inspectors	2
	Construction Manager	1
SWPL Loop-In	Foremen	3
	Linemen	15
138 kV Transmission Line	Operators	8
	Foremen	3
	Linemen	15
Boulevard Substation Rebuild	Superintendent	1
	Foreman	1
	Grade Checker	1
	Operators	5
	Inspector	1
<i>Subtotal</i>		89

Source: SDG&E 2009.

Table B-5
ECO Substation Project Typical Construction Equipment by Activity

Project Component	Activity	Approximate Number of People	Equipment	Use	Approximate Quantity	Approximate Duration on Site (8-hour days)	Average Duration of Use (hours per day)
ECO 500/230/138 kV Substation	Site Development	30	0.75-ton or 1-ton pickup truck	Transport and support construction personnel	10	130	2
		2	Maintenance truck	Maintain and refuel equipment	1	130	2
		3	Bulldozer	Grade pads and access roads	3	100	8
		2	Road grader	Construct, maintain, and upgrade roads	2	100	6
		5	Scraper	Grade pads and access roads	5	100	8
		2	Compactor	Grade pads and access roads	3	100	8
		3	Loader	Load dump trucks and stockpile	2	100	6
		2	Backhoe	Excavate	2	100	5
		1	Rock truck	Move rock	1	36	6
		1	Rock crusher	Crush rock	1	36	6
		3	Water truck	Suppress dirt	3	200	6
		20	Haul truck	Transport Class II import material	20	50	10
		2	Concrete truck	Place concrete	2	25	3
		30	Water truck	Transport water	30	100	2
		8	Asphalt paver	Pave access roads	2	20	6
		1	Asphalt emulsion truck	Pave access roads	1	20	6
3	Vibrating roller	Compact soil and asphalt	3	20	6		

East County Substation/Tule Wind/Energia Sierra Juarez Gen-Tie Projects
B. PROJECT DESCRIPTION

Table B-5 (Continued)

Project Component	Activity	Approximate Number of People	Equipment	Use	Approximate Quantity	Approximate Duration on Site (8-hour days)	Average Duration of Use (hours per day)
		5	Asphalt haul trucks	Transport asphalt	5	20	6
	Below-Grade Construction	30	0.75-ton or 1-ton pickup truck	Transport and support construction personnel	10	150	2
		10	Concrete truck	Pour concrete	10	75	3
		1	Maintenance truck	Maintain and refuel equipment	1	150	2
		6	Drill rig	Drill pier foundations	2	40	6
		3	Backhoe	Excavate pad foundations	3	80	6
		4	Forklift/skid steer	Move rebar, equipment, masonry, and other materials	4	75	6
		6	Light-duty crane	Place material and steel	2	60	4
		6	Trencher	Install grounding	2	60	7
		6	Backhoe	Duct bank and conduit installation	2	60	7
		1	Water truck	Suppress dust	1	150	6
		2	Compactor-handheld	Compact soil	2	80	6
		Above-Grade Construction	20	0.75-ton or 1-ton pickup truck	Transport and support construction personnel	10	150
	1		Maintenance truck	Maintain and refuel equipment	1	150	2
	15		Bucket truck/man-lift	Set steel and install equipment	5	100	6
	6		Crane	Place material and set steel	2	100	4

East County Substation/Tule Wind/Energia Sierra Juarez Gen-Tie Projects
B. PROJECT DESCRIPTION

Table B-5 (Continued)

Project Component	Activity	Approximate Number of People	Equipment	Use	Approximate Quantity	Approximate Duration on Site (8-hour days)	Average Duration of Use (hours per day)
		6	Boom truck	Place material and set steel	2	100	6
		2	Forklift	Unload and move material	2	100	6
	Communication Equipment Installation	4	Bucket truck	Set steel and install equipment	2	20	7
		2	Crane	Place material and set steel	2	20	7
	Testing and Commissioning	8	0.75-ton or 1-ton pickup truck	Transport and support construction personnel	4	40	2
		2	Heavy van	Transport and support construction personnel	2	40	2
		2	Man-lift	Outdoor check out of equipment	2	30	4
		1	Diesel generator (500 kW)	Extract and remove oil	1	5	24
		3	Crane	Extract and remove oil	1	5	5
	SWPL Loop-In	General Construction	4	0.75-ton or 1-ton pickup truck	Transport and support construction personnel	2	60
1			Maintenance truck	Maintain and refuel equipment	1	40	2
Access Roads		1	Bulldozer	Equipment access	1	10	4
Install Foundations		3	Concrete truck	Pour concrete	3	10	3
		2	Drill rig	Foundation construction	1	10	6
		2	Backhoe	Foundation construction	2	10	6
Tower Installation		4	Large crane	Tower erection	2	10	6

East County Substation/Tule Wind/Energia Sierra Juarez Gen-Tie Projects
B. PROJECT DESCRIPTION

Table B-5 (Continued)

Project Component	Activity	Approximate Number of People	Equipment	Use	Approximate Quantity	Approximate Duration on Site (8-hour days)	Average Duration of Use (hours per day)
	and Conductor Stringing	12	Bucket truck	Tower erection and conductor installation	4	30	8
		4	Puller and tensioner	Conductor installation	2	20	8
		4	Reel trailer	Conductor and installation	2	20	8
Overhead 138 kV Transmission Line	General Construction	2	Helicopter	Transport and install structures and conductor	1	60	4
		3	2-ton flatbed truck or flatbed boom truck	Haul and unload materials	2	60	4
		3	Rigging truck	Haul tools and equipment	3	60	4
		2	Mechanic truck	Service and repair equipment	2	60	4
		12	Aerial lift truck	Access poles, string conductor, and other uses	3	60	5
		2	Shop van	Store tools	2	90	4
		4	Small mobile crane (12 tons)	Load and unload materials	2	40	5
		2	Semi-tractor trailer	Haul structures and equipment	2	60	4
		4	Air compressors	Operate air tools	4	80	4
		6	Dump truck	Haul excavated material and import backfill	6	60	5
		3	0.75-ton or 1-ton pickup truck	Transport construction personnel	2	90	4
		1	Water truck	Suppress dust and fire	1	80	5
		2	Blasting rig	Break up rock and excavate	1	30	3

East County Substation/Tule Wind/Energia Sierra Juarez Gen-Tie Projects
B. PROJECT DESCRIPTION

Table B-5 (Continued)

Project Component	Activity	Approximate Number of People	Equipment	Use	Approximate Quantity	Approximate Duration on Site (8-hour days)	Average Duration of Use (hours per day)
	Access Roads	1	Bulldozer	Grade access roads and pole sites	1	80	5
		1	Front-end loader	Construct, maintain, and upgrade roads	1	80	5
		1	Road grader	Construct, maintain, and upgrade roads	1	80	5
		1	Compactor	Construct access roads	1	80	5
	Pole Foundation Installation	4	Concrete truck	Pour concrete	4	50	4
		2	Drill rig with augers	Excavate holes for foundation and pole installation	2	40	5
		2	Air tampers	Compact soil around structure foundations	2	60	4
	Pole Installation	2	Large mobile cranes (75 tons)	Erect structures	1	20	4
		1	Backhoe	Excavate trenches	1	3	5
	Conductor Stringing and Sagging	2	Take-up trailer	Install conductor	2	40	4
		10	Puller and tensioner	Pull conductor and wire	2	40	4
		5	Conductor reel trailer	Transport cable reels and feed cables into conduit	2	40	4
		2	Splice trailer	Store splicing supplies	2	40	4
Boulevard Substation	Site Development	10	0.75-ton or 1-ton pickup truck	Transport and support construction personnel	5	65	2
		1	Maintenance truck	Maintain and refuel equipment	1	65	2

East County Substation/Tule Wind/Energia Sierra Juarez Gen-Tie Projects
B. PROJECT DESCRIPTION

Table B-5 (Continued)

Project Component	Activity	Approximate Number of People	Equipment	Use	Approximate Quantity	Approximate Duration on Site (8-hour days)	Average Duration of Use (hours per day)
		2	Bulldozer	Grade pad, access road, clear and grub	1	50	6
		2	Scraper	Grade pad and access road	2	20	6
		2	Compactor	Compact soil and asphalt	2	50	4
		2	Loader	Load dump trucks and stockpile	2	40	8
		2	Backhoe	Excavate trenches	1	30	6
		1	Excavator	Grade pad	1	3	4
		1	Rock crusher	Crush rock	1	20	6
		1	Water truck	Suppress dust	1	65	5
		8	Haul truck	Export material	8	40	10
		8	Haul truck	Import Class II material	8	7	10
		4	Concrete truck	Place concrete	4	7	3
		15	Water truck	Transport water	15	25	2
		4	Asphalt paver	Pave access roads	1	5	6
		1	Asphalt emulsion truck	Pave access roads	1	5	6
		1	Vibrating roller	Compact soil and asphalt	1	25	4
		7	Asphalt haul trucks	Transport asphalt	7	5	6
		Below-Grade Construction	12	0.75-ton or 1-ton pickup truck	Transport and support construction personnel	3	72
	30		Concrete truck	Place concrete	1	30	8
	1		Maintenance truck	Maintain and refuel equipment	1	72	2
	1		Backhoe (with drill attachment)	Drill/excavate pier foundations	1	72	4

East County Substation/Tule Wind/Energia Sierra Juarez Gen-Tie Projects
B. PROJECT DESCRIPTION

Table B-5 (Continued)

Project Component	Activity	Approximate Number of People	Equipment	Use	Approximate Quantity	Approximate Duration on Site (8-hour days)	Average Duration of Use (hours per day)
		2	Skid steer loader	Transport soil	2	72	6
		1	Walk-behind trencher	Excavate trenches	1	72	4
		1	Water truck	Suppress dust	1	72	2
		2	Compactor – handheld	Compact soil	2	72	4
		60	Haul truck	Export material	2	30	4
	Above-Grade Construction	6	0.75-ton or 1-ton pickup truck	Transport and support construction personnel	8	50	3
		1	Maintenance truck	Maintain and refuel equipment	1	25	2
		6	Heavy van	Install/test batteries and breakers	2	40	2
		1	Boom truck	Support steel construction work	1	125	6
		4	Man-lift	Support bus and disconnect construction	2	125	6
		1	All-terrain extendable forklift	Support steel and equipment construction	1	125	6
		6	Crew assist vehicle	Transport tools for breaker and transformer installation and construction	4	62	2
		4	Tow-man bucket truck	Support the steel and transformer installation	2	95	4
		1	Bucket truck	Support 138 kV GCB installation	1	20	4
1	Small crane	Install transformers	1	6	6		

East County Substation/Tule Wind/Energia Sierra Juarez Gen-Tie Projects
B. PROJECT DESCRIPTION

Table B-5 (Continued)

Project Component	Activity	Approximate Number of People	Equipment	Use	Approximate Quantity	Approximate Duration on Site (8-hour days)	Average Duration of Use (hours per day)
		1	Diesel generator (500 kW)	Distribute oil	1	6	24
	Testing and Commissioning	2	0.75-ton or 1-ton pickup truck	Transport and support construction personnel	1	20	2
		3	Heavy van	Test relays and RTU	2	75	2
	Existing Substation Demolition	3	Backhoe with breaker attachment	Break and remove concrete foundations and backfill	1	5	6
		5	Haul truck	Remove concrete from site	5	2	3
		1	Roller compactor	Compact backfill	1	1	4
		2	Crane	Remove the transformer	1	1	6
		1	Haul truck	Remove debris	1	4	3
		2	Oil truck/pump	Extract and remove oil	2	3	3
		4	Man-lift	Support substation demolition	2	24	8
		1	Forklift	Transport materials	1	24	6
		1	Water truck	Suppress dust	1	24	2

Source: SDG&E 2009.

B.3.2.4 Water Usage

Approximately 30 million gallons of water would be required on site during the construction of the ECO Substation Project. Water would be obtained through a number of sources, including purchasing and transporting water from local water districts, drilling wells near the ECO Substation yards site, or purchasing and transporting water from the Sweetwater Authority or City of San Diego.

If drilling is a viable option, a local well-drilling contractor would be engaged to perform the drilling operation and the drill hole would be logged (per San Diego County requirements). Once an appropriate aquifer is reached, water quality tests and pump tests for quantity would be conducted by the drilling contractor. If the aquifer can supply an adequate amount of clean water, a submersible pump would be placed down the drill hole and the discharge would be connected to a water system to transport the water to the ECO Substation yards site.

If enough water cannot be located on site or purchased from nearby sources, water would be imported from a water district, such as the Sweetwater Authority or City of San Diego. The Sweetwater Authority in Chula Vista has confirmed that it has sufficient water capacity to provide 25 million gallons of water to the ECO Substation Project (Adam 2010). Assuming 4,000-gallon-size trucks, an additional 7,500 truck trips would be required to transport this water to the ECO Substation Project site. A maximum of 43 truck trips per day, delivering approximately 172,000 gallons of water, would be used to supply water during construction. Therefore, approximately 7,500 trips would be required over 8 months in order to supply the required 30 million gallons of water.

B.3.3 ECO Substation Project Operations and Maintenance

ECO 500/230/138 kV Substation

During operations, the ECO Substation would be unmanned. All substation monitoring and control functions would be performed remotely from SDG&E's central operations facilities. Unauthorized entry into the substation yards would be prevented by fencing and locked gates. Warning signs would be posted and entry to the new substation yards would be restricted to SDG&E authorized personnel. Accordingly, no new personnel would be required for operation and maintenance of the ECO Substation.

Routine operation would require a single pickup truck visiting the substation several times a week for switching, as well as several larger construction and maintenance trucks visiting the substation several times a year for equipment maintenance. Maintenance activities would include equipment testing, equipment monitoring and repair, and emergency and routine procedures for service continuity and preventive maintenance. Routine maintenance is

expected to require approximately six trips per year by a two- to four-person crew. Typically, a major maintenance inspection would take place annually, requiring approximately 20 personnel for approximately 1 week.

Safety lighting at the substation would be provided inside the substation fence for the purpose of emergency repair work. Since nighttime maintenance activities are not expected to occur more than once per year, the safety lighting inside the substation fence would normally be turned off. Two 100-watt yellow outdoor floodlights, one mounted near each entry gate to safely illuminate the substation entry gate, would be left on during nighttime hours. The lights would be directed downward to minimize glare on surrounding properties and habitat.

Routine vegetation clearing around the substation would occur on an as-needed basis for purposes of safety and access. These activities would typically involve the presence of one or two maintenance vehicles and one or more employees to clear or trim vegetation in order to achieve the minimum necessary working space around the substation and transmission line facilities.

SWPL Loop-In

Maintenance and repair activities for the SWPL Loop-In would be similar to those already being conducted for the SWPL transmission line. These activities include routine preventive maintenance and emergency procedures to maintain system integrity. Inspection work may require the use of helicopters for aerial patrol of the facilities, as well as ground patrol. At a minimum, routine land or aerial inspections would take place on an annual basis. These inspections would check for corrosion, equipment misalignment, loose fittings, and other common mechanical problems.

~~A minimum working space of 150 feet in diameter around~~Permanent maintenance pads, measuring 100 feet by 150 feet, beneath all transmission structures would be maintained by SDG&E. This area would be kept clear of shrubs and other obstructions for inspection and maintenance purposes. In addition, vegetation that has a mature height of 15 feet or taller would not be allowed to grow within 10 horizontal feet of any conductor within the ROW, for safety and reliability reasons.

In some areas prone to atmospheric moisture, condensation combined with dust on porcelain insulators can create an electrical discharge. This discharge, known as “arcing,” may cause outages. The outages caused by arcing can be prevented by routinely washing the insulators with deionized water. Washing insulators involves driving a water truck to within 6 feet of the facility and spraying the insulators with a high-pressure hose. A two-man crew driving a washer truck would be required for this operation and the required space would be roughly the same size as the truck. Insulator washing can typically be completed in 30 minutes. Insulators are typically

inspected on an annual basis to determine if washing is required. Insulator washing would only be conducted on the SWPL Loop-In structures and not on the new 138 kV transmission line.

138 kV Transmission Line

During operations, the 138 kV transmission line would be regularly inspected, maintained, and repaired. Operations and maintenance activities would involve both routine preventive maintenance and emergency procedures to maintain service continuity. Aerial and ground inspections of the ECO Substation Project facilities would be performed. Aboveground components would be inspected annually, at a minimum, for corrosion, equipment misalignment, loose fittings, and other common mechanical problems. The underground portion of the transmission line would be inspected annually from inside the concrete splice vaults.

Similar to the SWPL Loop-In, a minimum working space of 150 feet in diameter around all transmission structures would be maintained by SDG&E and kept clear of shrubs and obstructions for inspection and maintenance purposes. In addition, vegetation that has a mature height of 15 feet or taller would not be allowed to grow within 10 horizontal feet of any conductor within the ROW for safety and reliability reasons.

The following discussion provides an overview of the types of broad activities that would occur after the installation of the 138 kV transmission line. Unless otherwise noted, all vehicles would have rubber tires.

ROW Repair. Repair methods would include grading previously built (road re-establishment) and existing maintenance access roads and spot-repair of erosion sites subject to scouring. ROW repairs would be performed as necessary (such as following seasonal rains) and may require the use of a four-wheel-drive pickup truck, a motor grader, a backhoe, and/or a cat-loader. The cat-loader has steel tracks while the remaining equipment has rubber tires.

Pole or Structure Brushing. Certain poles or structures would require the removal of vegetation to increase aerial patrol effectiveness or to reduce fire danger. Vegetation would be removed using mechanical equipment, such as chainsaws, weed trimmers, rakes, shovels, and brush hooks. A crew of three workers would typically conduct this work. As stated previously, SDG&E would maintain a 150-foot-diameter area around each transmission structure. The total area needed to complete this task is approximately 100 feet by 100 feet and it takes approximately 2 hours to complete. Poles are typically inspected on an annual basis to determine if vegetation removal around poles is required.

Application of Herbicides. To prevent vegetation from reoccurring around structures, the application of herbicides may follow clearing activities. SDG&E normally utilizes one or more of 16 herbicides. These herbicides are identified in a U.S. Fish and Wildlife Service (USFWS)

letter to SDG&E, along with their recommendations, which is included in SDG&E's PEA as Attachment 3-E, Approved Herbicides and Application Procedures (SDG&E 2009). The application of herbicides generally requires one person and takes only minutes to spray around the base of the pole within a radius of approximately 10 feet. The employee would either walk from the nearest access road to apply the herbicide or drive a pick-up truck directly to each pole location as access permits.

Equipment Repair and Replacement. Poles or structures support a variety of equipment, such as conductors, insulators, switches, transformers, lightning arrest devices, line junctions, and other electrical equipment. In order to maintain uniform, adequate, safe, and reliable service, electrical equipment may need to be added, repaired, or replaced during operations. An existing transmission structure may be removed and replaced with a larger/stronger structure at the same location or a nearby location, due to damage or changes in conductor size. Equipment repair or replacement generally requires a crew to gain access to the location of the equipment to be repaired or replaced. The crew normally consists of four men with two to three trucks, a boom or line truck, an aerial-lift truck, and an assist truck. If no vehicle access exists, the crew and material are flown in by helicopter.

Insulator Washing. The 138 kV transmission line would use polymer insulators that do not require washing. Depending on the type of insulators used and the level of contamination, insulator washing may occur at the ECO and Boulevard Substations.

Tree Trimming. Tree limb contact with electrical lines can cause power outages. Regular inspection is necessary to maintain proper line clearances. Tree-trimming activities are typically conducted by a two-man crew, a one-man aerial lift truck, and a chipper trailer. In most cases, the crew has vehicle access; however, if vehicle access is not available, the crew would walk to the specific location to conduct the trimming. Although the time required to complete tree trimming varies by location, most tree-trimming activity can be completed in 1 day. Trees where electric facilities exist are inspected annually in SDG&E's service area.

Use of Helicopters. Each electric transmission line is inspected several times a year via helicopter. Helicopters may also be used to deliver equipment, position poles and structures, string lines, and position aerial markers, as required by Federal Aviation Administration (FAA) regulations. SDG&E's Transmission and Distribution Departments use helicopters for patrolling transmission and distribution lines during trouble jobs that are in areas of rough terrain or where vehicle access is limited. During trouble job patrolling, the helicopter either picks up the patrolman at the district yard or in the field. If the pick up occurs in the field, a pad or flat field to land on would be required. The area required for small helicopter staging is generally 100 feet by 100 feet and the size of the crew varies from 4 to 10 crewmembers, 2 helicopter staff, and a

water truck driver to apply water for dust control at the staging area. Most helicopter operations typically take 1 day.

Boulevard Substation

The rebuilding of the Boulevard Substation would have a minor effect on the operations and maintenance practices currently employed at the site. The rebuilt Boulevard Substation would be unmanned, as is the existing substation. Operations and control would occur via a remote control center. Unauthorized entry into the substation would be prevented by fencing and locked gates. Maintenance activities, including equipment testing, equipment monitoring and repair, emergency and routine procedures for service continuity, and preventive maintenance, would continue with the same crew sizes and visit frequency. The maintenance crews would be on site for a slightly longer duration due to the increase in station equipment.

B.3.4 ECO Substation Project Applicant Proposed Measures

Section 3.11 of the August 2009 PEA prepared by SDG&E details the APMs that would be followed during all project-related activities. APMs are specific to environmental issue areas, such as air quality, biological resources, cultural resources, or traffic impacts. Table B-6, ECO Substation Project Applicant Proposed Measures for Each Issue Area, lists APMs that are applicable to each environmental issue area, while Table B-7, ECO Substation Project Applicant Proposed Measures as Proposed in the PEA, lists the APMs as proposed by SDG&E.

All project-related activity is subject to the APMs. In addition, all project personnel are subject to training prior to beginning work on the project to ensure that the APMs, environmental laws and regulations, and all other agency requirements are understood and followed.

Table B-6
ECO Substation Project Applicant Proposed Measures for Each Issue Area

Issue Area	Applicable APMs
Aesthetics	ECO-AES-01 through ECO-AES-04
Air Quality	ECO-AIR-01 through ECO-AIR-13
Biological Resources	ECO-BIO-01 through ECO-BIO-30
Cultural Resources	ECO-CUL-01 through ECO-CUL-11
Geology and Soils	ECO-GEO-01
Hazardous Material, Public Health and Safety	ECO-HAZ-01 through ECO-HAZ-06
Hydrology and Water Quality	ECO-HYD-01 and ECO-HYD-02
Noise	ECO-NOI-01 through ECO-NOI-03

Table B-7
ECO Substation Project Applicant Proposed Measures as Proposed in the PEA

APM No.	Description
ECO-AES-1	In order to reduce potential visual contrast and integrate the ECO Substation's appearance with the desert landscape setting, when Project construction has been completed, all disturbed terrain at the ECO Substation site will be restored through recontouring and revegetation in accordance with the Landscaping Plan included as Figure 4.1–3: East County Substation Landscape Concept Plan.
ECO-AES-2	When Project construction has been completed, all disturbed terrain at the Boulevard Substation site will be restored through recontouring, revegetation, and landscaping in accordance with the Landscaping Plan included as Figure 4.1–4: Boulevard Substation Landscape Concept Plan. In order to provide screening and thus reduce potential Project visibility, the Landscape Plan includes larger shrubs and trees that will partially screen views of the substation from Old Highway 80 and from adjacent residential properties.
ECO-AES-3	In order to reduce the Project's potential visibility from Old Highway 80, the underground portion of the new 138 kV transmission line will be extended an additional distance of approximately 600 feet to the south and the steel cable riser pole will be relocated to replace structure SP-2.
ECO-AES-04	Construction activities will be kept as clean and inconspicuous as possible. Where practical, construction storage and staging will be screened with opaque fencing from close-range residential views.
ECO-AIR-01	Rock aprons or rattle plates will be installed, as needed, at the intersection of dirt access roads and paved public roadways to clean the tires of equipment prior to leaving the site.
ECO-AIR-02	All active construction areas, unpaved access roads, parking areas, and staging areas will be watered or stabilized with non-toxic soil stabilizers as needed to control fugitive dust.
ECO-AIR-03	All public streets will be swept or cleaned with mechanical sweepers if visible soil material is carried onto them by construction activities or vehicles.
ECO-AIR-04	Exposed stockpiles (e. g., dirt, sand, etc.) will be covered and/or watered or stabilized with non-toxic soil binders as needed to control emissions.
ECO-AIR-05	Trucks transporting bulk materials will be completely covered unless two feet of freeboard space from the top of the container is maintained with no spillage and loss of material. In addition, the cargo compartment of all haul trucks will be cleaned and/or washed at the delivery site after removal of the bulk material.
ECO-AIR-06	Movement of bulk material handling or transfer will be stabilized prior to handling or at a point of transfer with application of sufficient water, chemical stabilizers, or by sheltering or enclosing the operation and transfer line.
ECO-AIR-07	Traffic speeds on unpaved roads and the ROW will be limited to 15 miles per hour (mph).
ECO-AIR-08	SDG&E will limit actively graded areas to a cumulative total of 12.8 acres per day. The total area of disturbance can exceed this acreage so long as the actively graded portion is below this threshold.
ECO-AIR-09	Vehicle idling time will be limited to a maximum of five minutes for vehicles and construction equipment, except where idling is required for the equipment to perform its task.
ECO-AIR-10	Road graders used during site development activities at the ECO Substation will be equipped with a California Air Resources Board-verified Level 2 diesel emission control strategy or a comparable diesel-control technology that will reduce inhalable particulate matter (PM10) emissions by 50 percent or more.
ECO-AIR-11	If suitable park-and-ride facilities are available in the Project vicinity, construction workers will be encouraged to carpool to the job site to the extent feasible. The ability to develop an effective carpool program for the Project would depend upon the proximity of carpool facilities to the job site, the geographical commute departure points of construction workers, and the extent to which carpooling would not adversely affect worker show-up time and the Project's construction schedule.

East County Substation/Tule Wind/Energia Sierra Juarez Gen-Tie Projects
B. PROJECT DESCRIPTION

Table B-7 (Continued)

APM No.	Description
ECO-AIR-12	Routine inspections and preventative maintenance will be performed on all sulfur hexafluoride (SF6) equipment according to the manufacturer's recommendations. SF6 density will be monitored at all equipment and any changes exceeding the manufacturer's recommendations will be reported immediately to SDG&E. These activities will be tracked in SDG&E's substation maintenance software and reported to the California Climate Action Registry and the Assembly Bill 32 mandatory reporting regulation in compliance with the Environmental Protection Agency's mass-balance equation reporting and tracking method. Substation crews will be trained on these tracking procedures and the significance of SF6 as a greenhouse gas.
ECO-AIR-13	During final design, SDG&E will consider the feasibility of using rooftop photovoltaic panels on the control shelters to help support operating load at the ECO Substation. SDG&E will also investigate utilizing solar tubes for lighting in the control shelters. SDG&E's Project team will work closely with SDG&E's Sustainable Communities team to implement green building practices at the ECO Substation.
ECO-BIO-01	Littering will not be allowed. Food-related garbage and trash will be removed from the Project area daily.
ECO-BIO-02	Smoking will only be allowed in cleared areas or in enclosed vehicles to reduce the potential for wildfires.
ECO-BIO-03	All earth-moving equipment will be confirmed to be clean and free of mud and vegetative material before first arriving at the construction site. If the equipment leaves the Project site, it must be confirmed to be clean and free of mud and vegetative material prior to re-entering the site.
ECO-BIO-04	Firearms will be prohibited in all Project areas.
ECO-BIO-05	Project personnel will not be allowed to bring pets to any Project area to minimize harassment or killing of wildlife and to prevent the introduction of destructive animal diseases to native wildlife populations.
ECO-BIO-06	No harm, harassment, or collection of plant and wildlife species will be allowed. Feeding of wildlife will be prohibited.
ECO-BIO-07	A biological monitor will be present during all ground-disturbing and vegetation removal activities. Immediately prior to initial ground-disturbing activities and/or vegetation removal, the biological monitor will survey the site to ensure that no sensitive species will be impacted.
ECO-BIO-08	Prior to construction, all SDG&E, contractor, and subcontractor Project personnel will receive training regarding the appropriate work practices necessary to effectively implement the APMs and to comply with the applicable environmental laws and regulations, including appropriate wildlife avoidance; impact minimization procedures; the importance of these resources, and the purpose and necessity of protecting them; and methods for protecting sensitive ecological resources. The training will include BMPs to reduce the potential for erosion and sedimentation during construction of the Project.
ECO-BIO-09	Survey personnel will keep survey vehicles on existing roads. During Project surveying activities, brush clearing for footpaths, line-of-sight cutting, and land surveying panel point placement in sensitive habitat will require prior approval from the Project biological monitor. Hiking off roads or paths for survey data collection will be allowed year-round as long as all of the other applicable APMs are met.
ECO-BIO-10	Except when not feasible due to physical or safety constraints, all Project vehicle movement will be restricted to existing access roads and access roads constructed as a part of the Project and determined and marked by SDG&E in advance of construction. Approval from a biological monitor will be obtained prior to any travel off of existing access roads.
ECO-BIO-11	To the extent feasible, access roads will be built at right angles to streambeds and washes. Where it is not feasible for access roads to cross at right angles, SDG&E will limit roads constructed parallel to streambeds or washes to a maximum length of 500 feet at any one transmission line crossing location. Such parallel roads will be constructed in a manner that minimizes potential adverse impacts on waters of the U.S. or state-only waters. All access roads constructed parallel to or across these features will be approved by a biological monitor in advance.
ECO-BIO-12	Prior to construction of the 138 kV transmission line, surveys for sensitive plant species known to occur or with a moderate to high potential to occur within the Project area, as described in Chapter 4.4 Biological Resources, will be conducted for work areas and access roads during the appropriate phenological period. A report will be

Table B-7 (Continued)

APM No.	Description
	prepared that reflects the finding of these surveys and any associated impacts that would result from construction of the transmission line. This report will be submitted to the CPUC prior to the start of construction.
ECO-BIO-13	Prior to the start of construction, the boundaries of plant populations designated as sensitive by the USFWS or CDFG, and other resources designated sensitive by SDG&E and the resource agencies, will be delineated with clearly visible flagging or fencing. The flagging and/or fencing will be maintained in place for the duration of construction. Flagged and fenced areas will be avoided to the extent practicable during construction activities in that area.
ECO-BIO-14	If impacts to sensitive plant species are unavoidable, SDG&E will work with the appropriate jurisdictional agency (when practicable) to salvage the plant individuals utilizing methods, including removal and stockpiling for replanting on site, removal and transplanting out of surface disturbance area, or removal and salvage by an appropriate resource specialist.
ECO-BIO-15	SDG&E will conduct protocol-level surveys for QCB (<i>Euphydryas editha quino</i>) prior to construction. Once the surveys have been completed, a 45-day report will be submitted to the USFWS and CPUC.
ECO-BIO-16	SDG&E will work with Project engineers to relocate, if feasible, proposed SP 75 to avoid dense populations of any primary host plant of the QCB.
ECO-BIO-17	SDG&E will compensate for permanent impacts to suitable QCB critical habitat at a ratio of one to one or as agreed to in consultation with the USFWS.
ECO-BIO-18	SDG&E will compensate for permanent impacts to sensitive species habitat at a ratio of one to one or as agreed to in consultation with the USFWS and CDFG.
ECO-BIO-19	All steep-walled trenches or excavations used during construction will be inspected twice daily (early morning and evening) to protect against wildlife entrapment. Open construction holes will be covered overnight. Covers will be secured in place nightly, prior to workers leaving the site, and will be strong enough to prevent livestock or wildlife from falling into the hole. Holes and/or trenches will be inspected prior to filling to ensure the absence of mammals and reptiles. Excavations will be sloped on one end to provide an escape route for small mammals and reptiles. If wildlife is located in the trench or excavation and cannot escape unimpeded, the biological monitor will be called immediately to remove them. The biological monitor will make the required contacts with USFWS and CDFG resource personnel and obtain verbal approval prior to removing any entrapped protected wildlife species. If the biological monitor is not qualified to remove the entrapped wildlife, a recognized wildlife rescue agency (such as Project Wildlife) will be employed to remove the wildlife and transport them safely to other suitable habitats.
ECO-BIO-20	Permanent retention basins will be constructed with escape ramps along two sides of the pond to allow entrapped wildlife to escape. The slope of the ramps will not exceed a two to one ratio and will be constructed of non-slippery material, or as specified by the biological monitor.
ECO-BIO-21	If feasible, SDG&E will avoid construction during the nesting or breeding season. When it is not feasible to avoid construction during the nesting or breeding season, SDG&E will perform a site survey in the area where the work is to occur. This survey will be performed to determine the presence or absence of nesting birds or other species in the work area. If an active nest is identified, a biological monitor will monitor the nest and determine a suitable construction buffer to ensure that the birds are not disturbed. If the birds are federal or state-listed species, SDG&E will consult with the USFWS and CDFG as necessary to determine the construction buffer. Monitoring of the nest will continue until the birds have fledged.
ECO-BIO-22	Prior to construction, SDG&E will remove all existing raptor nests from existing structures that will be affected by Project construction. Removal of nests will occur outside of the raptor breeding season (January to July). If it is necessary to remove an existing raptor nest during the breeding season, a qualified biologist will survey the nest prior to removal to determine if it is active. If the nest is inactive, it will be dismantled and removed from the site promptly under the supervision of a biological monitor. If the nest is determined to be active, it will not be removed and the biological monitor will monitor the nest to ensure nesting activities and/or breeding activities are not disrupted. If the biological monitor determines that Project activities are

East County Substation/Tule Wind/Energia Sierra Juarez Gen-Tie Projects
B. PROJECT DESCRIPTION

Table B-7 (Continued)

APM No.	Description
	disturbing or disrupting nesting activities, the monitor will make recommendations to reduce the noise and/or disturbance in the vicinity of the nest.
ECO-BIO-23	Construction night lighting in sensitive habitats will be minimized to the extent feasible. Exterior lighting within the Project area and adjacent to undisturbed habitat will be the lowest illumination allowed for human safety, selectively placed, shielded, and directed away from preserved habitat to the maximum extent practicable.
ECO-BIO-24	Nighttime vehicle traffic volume associated with Project activities will be kept to a minimum and speeds will be limited to 10 miles per hour to prevent mortality of nocturnal wildlife species.
ECO-BIO-25	Structures will be constructed to conform to the Avian Power Line Interaction Committee's Suggested Practices for Avian Protection on Power Lines to help minimize impacts to raptors.
ECO-BIO-26	At the completion of the Project, all construction materials will be removed from the site.
ECO-BIO-27	All new access roads constructed as part of the Project that are not required as permanent access for future Project operation and maintenance will either be restored or permanently closed. Where required, roads will be permanently closed using the most effective feasible and least environmentally-damaging methods appropriate to that area (e.g., stockpiling and replacing topsoil or replacing rock), with the concurrence of the underlying landowner and the governmental agency having jurisdiction.
ECO-BIO-28	Topsoil located in areas to be restored will be conserved during excavation and reused as cover on disturbed areas to facilitate regrowth of vegetation. Topsoil located in developed or disturbed areas is excluded from this APM.
ECO-BIO-29	Wherever possible, vegetation will be left in place to avoid excessive root damage and to allow for resprouting.
ECO-BIO-30	Temporarily disturbed areas will be reseeded with an appropriate seed mix that does not contain invasive, non-native plant species in accordance with landowner approval.
ECO-CUL-01	Prior to construction, all SDG&E, contractor, and subcontractor Project personnel will receive training regarding the appropriate work practices necessary to effectively implement the APMs and to comply with the applicable environmental laws and regulations, including the potential for exposing subsurface cultural resources and paleontological resources and to recognize possible buried resources. This training will include presentation of the procedures to be followed upon discovery or suspected discovery of archaeological materials, including Native American remains, and their treatment, as well as of paleontological resources.
ECO-CUL-02	At least 120 days prior to construction, a cultural/historical resource consultant will be retained by SDG&E to complete an analysis and assessment of the potential to disturb resources that were identified during the initial studies from major ground-disturbing activities. The analysis and assessment will be prepared to meet the requirements of the CEQA and NEPA. Project component sites that require testing for significance determination will be treated on a case-by-case basis using all applicable criteria.
ECO-CUL-03	A qualified archaeologist will attend preconstruction meetings, as needed, to make comments and/or suggestions concerning the monitoring program and to discuss excavation plans with the excavation contractor. The requirements for archaeological monitoring will be noted on the construction plans. The archaeologist's duties will include monitoring, evaluation, analysis of collected materials, and preparation of a monitoring results report conforming to agency guidelines for the Determination of the Significance of Archaeological Sites.
ECO-CUL-04	Known cultural resources that can be avoided will be demarcated as Environmentally Sensitive Areas. Construction crews will be instructed to avoid disturbance of these areas.
ECO-CUL-05	In the event that cultural resources are discovered, the archaeologist will have the authority to divert or temporarily halt ground disturbance to allow evaluation of potentially significant cultural resources. The archaeologist will contact SDG&E's Cultural Resource Specialist and Environmental Project Manager at the time of discovery. The archaeologist, in consultation with SDG&E's Cultural Resource Specialist will determine the significance of the discovered resources. SDG&E's Cultural Resource Specialist and Environmental Project Manager must concur with the evaluation procedures to be performed before construction activities are allowed to resume. For significant cultural resources, a Research Design and Data Recovery Program will be prepared and carried out to mitigate impacts.

East County Substation/Tule Wind/Energia Sierra Juarez Gen-Tie Projects
B. PROJECT DESCRIPTION

Table B-7 (Continued)

APM No.	Description
ECO-CUL-06	All collected cultural remains will be cleaned, cataloged, and permanently curated with an appropriate institution. All artifacts will be analyzed to identify function and chronology as they relate to the history of the area. Faunal material will be identified as to species.
ECO-CUL-07	A monitoring results report (with appropriate graphics), which describes the results, analyses, and conclusions of the monitoring program, will be prepared and submitted to SDG&E's Cultural Resource Specialist and Environmental Project Manager following termination of the program. Any noteworthy cultural sites or features encountered will be recorded with the South Coastal Information Center at San Diego State University and with the San Diego Museum of Man.
ECO-CUL-08	Prior to construction, a paleontological resource consultant will be retained by SDG&E to complete an analysis and assessment of the potential to disturb resources from major ground-disturbing activities, such as facility pad grading, trenching, or new access road grading.
ECO-CUL-09	A qualified paleontologist will attend preconstruction meetings, as needed, to consult with the excavation contractor concerning excavation schedules, paleontological field techniques, and safety issues. A qualified paleontologist is defined as an individual with a Master of Science or Doctor of Philosophy in paleontology or geology who is experienced with paleontological procedures and techniques, who is knowledgeable in the geology and paleontology of Southern California, and who has worked as a paleontological mitigation project supervisor in the region for at least one year. The requirements for paleontological monitoring will be noted on the construction plans.
ECO-CUL-10	A paleontological monitor will work under the direction of the qualified Project paleontologist and will be on site to observe excavation operations that involve the original cutting of previously undisturbed deposits with high paleontological resource sensitivity (i.e., Table Mountain Formation). A paleontological monitor is defined as an individual who has experience in the collection and salvage of fossil materials. Because the Miocene-age Table Mountain Formation is locally covered by Pleistocene-age Older alluvium and fan conglomerate deposits of unknown thickness, careful monitoring of excavations of the younger deposits will be necessary to ensure that overall monitoring of the Table Mountain Formation is as complete as possible. However, if site-specific geotechnical studies are sufficient to distinguish the geologic contact between the Pleistocene and Miocene sedimentary rock units, this information can be used to more clearly define those portions of the excavations solely sited in the Table Mountain Formation. If this level of detail is achieved prior to excavating activities, a paleontological monitor will need to be on site only on a part-time basis to observe excavation operations that involve the original cutting of previously undisturbed deposits of moderate paleontological resource sensitivity (i.e., older alluvium and fan conglomerate deposits).
ECO-CUL-11	In the event that fossils are encountered, the Project paleontologist will have the authority to divert or temporarily halt construction activities in the area of discovery to allow recovery of fossil remains in a timely fashion. The paleontologist will contact SDG&E's Cultural Resource Specialist and Environmental Project Manager at the time of discovery. The paleontologist, in consultation with SDG&E's Cultural Resource Specialist will determine the significance of the discovered resources. SDG&E's Cultural Resource Specialist and Environmental Project Manager must concur with the evaluation procedures to be performed before construction activities are allowed to resume. Because of the potential for recovery of small fossil remains, it may be necessary to set up a screen-washing operation on site. When fossils are discovered, the paleontologist (or paleontological monitor) will recover them along with pertinent stratigraphic data. In most cases, this fossil salvage can be completed in a short period of time. Because of the potential for recovery of small fossil remains, such as isolated mammal teeth, recovery of bulk-sedimentary-matrix samples for off-site wet screening from specific strata may be necessary, as determined in the field. Fossil remains collected during monitoring and salvage will be cleaned, repaired, sorted, cataloged, and deposited in a scientific institution with permanent paleontological collections.

East County Substation/Tule Wind/Energia Sierra Juarez Gen-Tie Projects
B. PROJECT DESCRIPTION

Table B-7 (Continued)

APM No.	Description
ECO-GEO-01	SDG&E will consider the recommendations and findings of final Geotechnical Reports prepared by URS and the contractor's Geotechnical Engineer in the final design of all Project components to ensure that the potential for expansive soils and differential settling is compensated for in the final design and construction techniques. In addition, SDG&E will comply with all applicable codes and seismic standards. The final design will be reviewed and approved by a Professional Engineer registered in the State of California prior to construction.
ECO-HAZ-01	Prior to construction, all SDG&E, contractor, and subcontractor Project personnel will receive training regarding the appropriate work practices necessary to effectively implement the APMs to comply with the applicable environmental laws and regulations associated with hazardous materials.
ECO-HAZ-02	A Phase II ESA will be conducted on the existing Boulevard Substation parcel after the equipment has been removed to determine if there is any surface or subsurface contamination. If required by the Phase II investigation, remediation will occur in accordance with all applicable federal, state, and local regulations.
ECO-HAZ-03	During the Boulevard Substation dismantling process, the existing equipment to be dismantled will be tested in accordance with federal, state, and local standards to determine appropriate recycle, reuse, or disposal alternatives.
ECO-HAZ-04	Soil testing for lead contamination will be conducted for all excavation sites within 500 feet of the informal shooting ranges. In addition, an Unanticipated Soil/Lead Contamination Handling Plan will be prepared to address the procedures to follow in the event that lead contamination is discovered during testing or excavation activities. This plan will contain provisions for a worker lead awareness program, as well as guidelines for the identification, removal, transport, and disposal of lead-impacted materials. This plan will also emphasize that all activities within, or in close proximity to, contaminated areas will follow applicable environmental and hazardous waste laws and regulations.
ECO-HAZ-05	SDG&E will develop a Construction Fire Prevention Plan for the Project and monitor construction activities to ensure its implementation and effectiveness. At a minimum, the Construction Fire Prevention Plan will include the following: <ul style="list-style-type: none"> • A description of the procedures that will be implemented to minimize the potential to start a fire (including vegetation clearing, parking requirements, etc.), • The requirements of Title 14 of the California Code of Regulations, Article 8 #918 "Fire Protection," • Relevant components of the SDG&E Wildland Fire Prevention and Fire Safety Electric Standard Practice (2009) included in Attachment 4.7 B: SDG&E Wildland Fire Prevention and Fire Safety Electric Standard Practice, • The fire-fighting equipment (including shovels, axes, and fire extinguishers) that must be maintained on site and in vehicles for the duration of construction, • The appropriate timing and use of fire-protective mats or shields during grinding and welding operations, – emergency response and reporting procedures, and • Relevant emergency contact information. SDG&E will provide a draft copy of the Construction Fire Prevention Plan to the California Public Utilities Commission (CPUC), CAL FIRE, the Bureau of Land Management, County of San Diego, and local community fire departments at least 90 days before the start of any construction activities. Agency comments on the Construction Fire Prevention Plan will be provided by SDG&E to all other reviewing parties and SDG&E will resolve each comment in consultation with CAL FIRE. The final Construction Fire Prevention Plan will be approved by CAL FIRE at least 30 days prior to the initiation of construction activities. SDG&E will fully implement the Construction Fire Prevention Plan during all construction activities.
ECO-HAZ-06	SDG&E will implement the Wildland Fire Prevention and Fire Safety Electric Standard Practice (2009) included as Attachment 4.7–B: SDG&E Wildland Fire Prevention and Fire Safety Electric Standard Practice (2009) during all construction, operation, and maintenance work associated with the Project.

Table B-7 (Continued)

APM No.	Description
ECO-HYD-01	SDG&E will compensate for permanent impacts to any waters of the U.S. and state-only waters at a minimum ratio of one to one or as required by the USACE, CDFG, and RWQCB through their respective permitting processes.
ECO-HYD-02	If groundwater wells at ECO Substation are drilled within 0.5 mile of any local wells used for residential water supply, the water level in existing wells will be monitored and frequent communications will occur with the owner during construction to ensure that water availability is not adversely affected.
ECO-NOI-1	Construction activities will occur during the times established by the local ordinances (generally between 7 a.m. and 7 p.m. Monday through Saturday), with the exception of certain activities where nighttime and weekend construction activities are necessary, including, but not limited to, delivery of substation transformers, filling of substation transformers, system transfers, pouring of foundations, and pulling of the conductor, which require continuous operation or must be conducted during off-peak hours per agency requirements. For any work that cannot occur during those timeframes, SDG&E will limit construction activities so that noise will not exceed an hourly average of 45 dB when measured at the border of the nearest parcel with an inhabited residence. If activities cannot be limited to meet this noise threshold, SDG&E will communicate the exception to San Diego County in advance of conducting the work that will exceed the threshold. <u>If necessary, SDG&E will temporarily relocate residents occupying properties located less than 220 feet from construction activities on an as-needed basis for the duration of construction activities that would affect them (SDG&E 2011).</u>
ECO-NOI-2	SDG&E will provide notice of the construction plans to all property owners within 300 feet of the Project by mail at least one week prior to the start of construction activities. The announcement will state the construction start date, anticipated completion date, and hours of operation, and well as provide a telephone contact number for receiving questions or complaints during construction
ECO-NOI-3	Helicopter operation will be prohibited during construction of the 138 kV transmission line in the immediate vicinity of pole SP-52, located at approximate MP 7.3, and between pole SP-26, located at approximate MP 10.5, and the Rebuilt Boulevard Substation. If helicopter use cannot be avoided in these locations, SDG&E will temporarily relocate the impacted residents, on an as-needed basis, for the duration of the helicopter use that would impact them.
ECO-NOI-4	The use of explosives to assist with the excavation of rock will be prohibited within 600 feet of the boundary of any occupied parcels zoned for residential use and within 430 feet of the boundary of any occupied parcels zoned for agricultural use. If the use of explosives cannot be avoided in these locations, SDG&E will temporarily relocate the impacted occupants on an as-needed basis for the duration of the explosive use in their locations.

B.4 Tule Wind Project

This section details the Tule Wind Project components and design specifications, describes the construction activities and procedures associated with the Tule Wind Project, explains the O&M procedures, and presents a comprehensive listing of ~~Pacific Wind Development~~ Tule Wind, LLC's APMs to reduce potential impacts resulting from the Tule Wind Project.

B.4.1 Project Components

~~Tule Wind, LLC Pacific Wind Development~~ is requesting a minimum 30-year ROW grant from the BLM to construct and operate the Tule Wind Project in the In-Ko-Pah Mountains near the McCain Valley. The Tule Wind Project would be north of I-8, approximately 6 miles north of the community of Boulevard, in southeastern San Diego County, California (Figures B-1, Regional Map, and B-2B, Vicinity/Overview Map). The project is located on lands

administered by the BLM, the El Centro Field Office; BIA; Ewiiapaayp Indian Reservation; Manzanita; and Campo Indian Reservations (access only); the CSLC; and private lands under County of San Diego jurisdiction. The Tule Wind Project consists of up to ~~134~~128 wind turbines in the 1.5 to 3.0 MW range capable of generating up to ~~200~~201 MW of electricity. In addition to wind turbines and associated generator step-up transformers, the Tule Wind Project would include the following components:

- A 34.5 kV overhead and underground collector cable system linking each turbine to the next and the wind turbines to the collector substation
- A 5-acre collector substation site and a 5-acre O&M building site
- ~~Two~~Three permanent MET towers and one SODAR unit or one LIDAR unit
- A 138 kV overhead transmission line running south from the collector substation to be interconnected with the rebuilt SDG&E Boulevard Substation
- ~~36.3~~36.76 miles (~~192,074.2~~194,092.8 linear feet) of newly constructed access roads
- ~~27.6~~23.44 miles (~~145,834.5~~123,763.2 linear feet) of widened and improved existing access roads
- One temporary 5-acre concrete batch plant
- One 5,000-square-foot O&M building
- Up to three temporary use water wells for construction (on private land only, not to be placed on public lands)
- One permanent water well for the O&M building
- One septic tank and leach field for the O&M building
- One temporary 10-acre parking area
- Nineteen 2-acre temporary laydown and staging areas totaling 38 acres.

Table B-8, Summary of Tule Wind Project Components, provides an overview, general location, and temporary and permanent impacts for each project component. Figures B-2B, Vicinity/Overview Map, and B-19B, Tule Wind Project Overview, depict the location of major components.

**Table B-8
Summary of Tule Wind Project Components**

Project Component	Location	Description	Project Impacts	
			Temporary Impacts (acres) ¹	Permanent Impacts (acres)
Wind Turbines	Primarily on BLM land in the McCain Valley in southeastern San Diego County, north of Boulevard and I-8.	Construction and installation of up to 134 <u>128</u> wind turbines in the 1.5 to 3.0 MW range. The specific turbine layout would be capable of generating 200 <u>201</u> MW of electricity. Each turbine would be mounted on a concrete pedestal, supported by pad and a permanent concrete foundation and would be a maximum of 492 feet tall. Each turbine tower would include a transformer either located on a pad at the base of each turbine, or within the wind turbine itself pad-mounted transformer at its base , which would step-up electricity produced by the generator (located in the nacelle) to 34.5 kV.	0	386.5 <u>369.3</u>
Overhead and Underground 34.5 kV Cable Collection System	Each turbine string would be connected by the underground cable system, which would then connect to the overhead system.	The underground and overhead 34.5 kV collector cable system would collect and transfer electricity generated by the wind turbines to the collector substation. The underground system would transport electricity from wind turbine strings to a centrally located overhead system (several turbine strings would be directly connected to the collector substation via the underground system). The overhead system would deliver electricity to the collector substation.	408.2 <u>127</u>	0.02

East County Substation/Tule Wind/Energia Sierra Juarez Gen-Tie Projects
B. PROJECT DESCRIPTION

Table B-8 (Continued)

Project Component	Location	Description	Project Impacts	
			Temporary Impacts (acres) ¹	Permanent Impacts (acres)
Collector Substation	On BLM-administered land, approximately 7.5 miles northwest of the Boulevard Substation Rebuild Site. The collector substation would be located within a fenced 5-acre site.	The collector substation would receive electricity generated by the wind turbines and step-up the voltage from 34.5 to 138 kV.	0	5
Operations and Maintenance Facility	On BLM-administered land, collocated with the collector substation site. The O&M facility would be located within a fenced, 5-acre site.	The 5,000-square-foot O&M building would store house operationsal services, staff, equipment, spare parts, and would be the base of operations for the permanent O&M staff.	0	5
MET Towers and SODAR/LIDAR Unit	On BLM-administered land. One MET tower would be located in the vicinity of the collector substation, and the second <u>and the second</u> other would be within the Lark Canyon OHV Area, north of Rough Acres Ranch, and the third would be located on the ridge in the northern portion of the project area. <u>and the third would be located on the ridge in the northern portion of the project area.</u> The SODAR or LIDAR unit would be located within the Lark Canyon OHV Area.	MET towers would be installed to monitor the wind speed and direction. The towers would be approximately 200 feet <u>approximately 219 to 328-feet</u> tall.	0.048064	0.062083
Overhead 138 kV Transmission Line	The transmission line would run south from the collector substation, along and on either side of McCain Valley Road, traversing BLM, state, and County of San Diego land north of I-8, and would cross I-8 prior to interconnecting with the rebuilt Boulevard Substation.	The new 9.792-mile 138 kV transmission line connecting the Tule Wind Project collector substation and the rebuilt Boulevard Substation would include a maximum of 408 <u>approximately 80</u> steel transmission poles.	44.603	0.4209

East County Substation/Tule Wind/Energia Sierra Juarez Gen-Tie Projects
B. PROJECT DESCRIPTION

Table B-8 (Continued)

Project Component	Location	Description	Project Impacts	
			Temporary Impacts (acres) ¹	Permanent Impacts (acres)
Access Roads	Primarily on BLM-administered land and across Rough Acres Ranch.	In order to access proposed turbine locations and facilitate delivery of wind turbine components, approximately 27.6 <u>23.4</u> miles of existing roadways in the project area would be improved and approximately 36.4 <u>36.8</u> miles of new access roads would be constructed. All roads to and between turbine strings would temporarily be 36 feet wide to allow the large crane (required to hoist and mount turbine components) to move between turbines. After construction, access roads would be reduced to between 18 and 24 feet wide depending on the applicable jurisdiction.	84.2 <u>83.5</u>	466.4 <u>152.6</u>

¹. See Section B.4.2.2 for further details regarding temporary workspace requirements.

B.4.1.1 Wind Turbines

Location

Wind turbines and associated equipment would be located in the In-Ko-Pah Mountains north of the community of Boulevard (Figures B-2B, Vicinity/Overview Map, B-19B, Tule Wind Project Overview, and B-20B through B-22B, Tule Wind Project). The topography of the area is gently to moderately sloping and ranges in elevation from 3,600 to 5,600 feet above mean sea level (Pacific Wind Development 2009). The current project site layout identifies ~~134-128~~ turbines in the 1.5 to 3.0 MW range, including ~~97-96~~ on BLM lands, ~~17-18~~ on the Ewiiapaayp Indian Reservation, 7 on CSLC land, and ~~13-7~~ on privately owned lands (Rough Acres Ranch, within the permitting jurisdiction of San Diego County).

Depending on site topography, an approximatelyA 200-foot radius (approximately 2.88-acre) area around each turbine would be cleared (Figure B-23, Tule Wind Project Typical Turbine Site). The cleared area would be revegetated with fire-safe vegetation consistent with fire agency standard practices. This area is assumed to be permanently impacted. Total permanent impacts of the ~~134-128~~ wind turbines would be ~~386.5369.3~~ acres and would include the wind turbine base and foundation, pad-mounted transformer, and a gravel driveway from the turbine string access road to the individual turbine. In the construction area of the pad sites for the wind turbines and gravel driveways, slope areas would require grading of rock and dirt. The slopes would all be constructed in accordance with the latest International Building Codes and be treated with specific landscaping and erosion controls.

Description

Wind turbines would consist of three main parts: the turbine tower, turbine rotor, and the nacelle (Figure B-24, Tule Wind Project Typical Turbine Tower Design). Measured from the ground to the turbine blade tip, the typical turbine would be a maximum of 492 feet tall and would be mounted on a concrete ~~pad and pedestal, supported by~~ a permanent concrete foundation, which would be located belowground surface. The turbine tower typically consists of three tubular steel pole sections. A turbine rotor and the nacelle (which includes the electrical generator) would be mounted on top of each turbine tower, for a rotor hub height of up to 328 feet. Computer systems would be installed in each turbine and would routinely perform self-diagnostic tests and would allow a remote operator to set new operating parameters, perform system checks, and ensure turbines are operating at peak performance. As a standard safety precaution, turbines would automatically shut down if sustained winds or gusts exceed predetermined set points established by the turbine manufacturer to prevent equipment failure in the project area reach 50 mph or gusts reach about 56 mph. ~~A pad-mounted transformer would also be located at the base of each turbine and~~ Each turbine would also be equipped with a transformer that would step-up the

electricity received from the generator at 575-600 to 690 volts to 34.5 kV. Depending upon the turbine type selected, the transformer would either be located on a pad at the base of each turbine, or within the wind turbine itself (Iberdrola Renewables 2011a).

Turbines in the same geographical location would be grouped in rows or strings and connected by an underground and overhead collector cable system. The amount of turbines per string varies. For example, 19-17 turbines are proposed in the G-turbine string while only 2 turbines are proposed in the Q-turbine string. All turbines have been assigned an alphanumeric identification for tracking and design purposes (Figures B-19 through B-22).

In compliance with FAA rules (Advisory Circular (AC) 70/7460-1K: Obstruction Marking and Lighting), all turbine components, including towers, nacelles, and rotors, would be painted or finished using low-reflectivity, neutral white colors. The small cabinets containing the pad-mounted equipment at the base of each turbine tower would be painted with earth tone finishes, helping cabinets blend in with the surrounding ground. To minimize the potential for perching, external ladders and platforms would not be placed on tubular towers and guy wires would not be used on turbine towers.

Exterior lighting installed on turbines would be restricted and would only include FAA aviation warning lights. The minimum required number of lights would be installed and the minimum intensity of light would be used to meet FAA standards.

B.4.1.2 Overhead and Underground 34.5 kV Collector Cable System

Location

~~Pad-mounted~~ Transformers within the wind turbine or at the base of the proposed turbines would be connected to an underground and overhead electrical system shown on Figures B-19B, Tule Wind Project Overview, and B-20 through B-22, Tule Wind Project.

The overhead collector cable system would be supported by ~~a maximum of~~ approximately 250 ~~232~~ wood or steel poles. Poles would be between 60 and 80 feet in height and would be approximately 2 feet in diameter. Therefore, the overhead collector cable system would result in permanent impacts to 0.02 acres (approximately 871 square feet). The underground collector cable system construction footprint would include a 24-foot-wide temporary disturbance area and would not result in permanent land disturbances.

Description

The underground collector cable system would connect turbines located in the same strings and transmit electricity generated by the turbines to a centrally located overhead collector cable

system (several turbine strings in close proximity to the collector substation would be directly connected to the collector substation by the underground collector cable system). The overhead system would then transmit the generated electricity to the collector substation.

The underground collector cable system would ~~primarily be located underground and~~ placed within a ~~4244-~~ to 50-inch-deep and 12-inch-wide cable trench generally located along the length of the proposed turbine access roads. The underground collection system would consist of a network of 34.5 kV circuits that would collect and deliver electricity from the wind turbine generators to the collector substation. Although the size of the cable would vary depending on the designed electrical load, each circuit would consist of three 35 kV cables and all cables would have stranded aluminum conductors, cross-linked polyethylene insulation, and a copper concentric shield neutral/ground wire in a black polyethylene jacket. The circuits would also feature a bare copper or copper-clad trench neutral/ground wire and a fiber-optic cable for turbine generator management and control. Cables comprising each circuit would be placed in the cable trench in a tight trefoil configuration and backfilled with select soil free of rocks and debris previously set aside during trench excavation. With the exception of riser poles, no conduits would be used for power cables. A typical underground cable system trench is depicted on Figure B-25, Tule Wind Project Typical Underground Collector Cable System Trench.

Concrete or fiberglass vaults and splice boxes would be placed along the underground cable system where necessary. Vaults would be approximately 5 feet wide by 5 feet tall by 5 feet long and spaced approximately 2,500 feet apart. Boxes would have locked lids to control access.

Where site-specific conditions dictate (such as at steep canyon crossings and soil conditions not conducive to underground collector construction), the collector cable system would be placed aboveground. The aboveground collector system would utilize ~~a maximum of 232~~approximately 250 wood or steel poles approximately 60 to 80 feet in height, with single and double circuit collectors. Taller poles may be required at wash or drainage crossings. A typical 34.5 kV line design is shown on Figures B-26a, Tule Wind Project Typical 34.5 kV Overhead Collector Cable System Transmission Pole – ~~Single-Double~~ Circuit, and B-26b, Tule Wind Project Typical 34.5 kV Overhead Collector Cable System Transmission Pole – ~~Double-Single~~ Circuit.

B.4.1.3 Collector Substation

Location

The collector substation would be located on a 5-acre site on BLM-administered land approximately 7.5 miles northwest of the Boulevard Substation (Figures B-2B, Vicinity/Overview Map, B-19B, Tule Wind Project Overview, and B-20B, and B-21B, Tule

Wind Project). The collector substation would be located adjacent to the proposed Tule Wind O&M facility site on BLM-administered land.

The fenced portion of the Tule Wind collector substation would encompass approximately 5 acres (Figures B-20B and B-21B, Tule Wind Project).

Description

The proposed collector substation would increase the voltage received from the overhead and underground collector system from 34.5 to 138 kV. Switching and transformer equipment would be located on site, as would a control house and a parking area for utility vehicles. The area surrounding the substation would consist of gravel. Security fencing would be installed around the perimeter of the collector substation site. The substation fence would be a minimum of 7 feet tall, made of fabric, topped by 3 strands of barbed wire. Figure B-27, Tule Wind Project Plan View of a Typical Collector Substation, provides a typical plan view of the proposed collector substation.

Substation equipment would include two (~~138 and~~ 34.5 kV to 138 kV) 100-megavolt ampere power transformers that would be connected through 138 kV circuit breakers to a ~~common~~ 138 kV transmission line located within the fenced boundary of the substation. The low side of each transformer would be connected through a 34.5 kV circuit breaker to a split 34.5 kV bus, which would include open racks made of wide-flange steel. Up to eight feeder positions (each position would be protected with a circuit breaker) would be located on each side of the 34.5 kV bus. All 138 and 34.5 kV equipment is expected to be outdoor type.

The tallest structure in the collector substation would be the 138 kV pull-off structure, which will dead-end the 138 kV conductors. Figure B-28, Tule Wind Project Typical Collector Substation Profile, shows that the maximum height for the 138 kV pull-off structure would be approximately 50 feet from final finished grade of the collector substation site.

An access road would be constructed off McCain Valley Road to provide access to the collector substation (Figures B-20B and B-21B, Tule Wind Project).

Most of the substation equipment would feature a low-reflectivity finish to minimize the potential for glare. Dull grey porcelain insulators would be used to minimize visibility. Outdoor nighttime lighting at the collector substation facility would be kept to the minimum required for security and safety, and all lighting would be turned off when not required. To minimize backscatter and off-site light trespass, all lighting would be hooded and directed downward.

B.4.1.4 Operations and Maintenance Facility

Location

The proposed O&M facility would be located on a 5-acre site adjacent to the collector substation site (Figures B-2B, Vicinity/Overview Map, B-19B, Tule Wind Project Overview, ~~and B-20B,~~ and B-21B, Tule Wind Project).

Figures B-20B and B-21B (Tule Wind Project) depict the fenced portion of the Tule Wind O&M facility, which would encompass approximately 5 acres.

Description

Operational equipment and spare parts for the Tule Wind Project would be located within an approximate 5,000-square-foot, pre-engineered, one-story metal O&M building, which would be located on a maximum 5-acre area. ~~A 4-acre cleared~~The area ~~would~~ surrounding the O&M building would be cleared. A ~~central~~ computer system that would facilitate remote operations of the proposed turbines would be accessible at ~~is anticipated to be located in~~ the O&M building. In addition, an electrical, heating, ventilation, ~~and~~ air conditioning (HVAC) system, a septic system, fire suppression system, and groundwater well would also be installed within the O&M building, as the permanent O&M staff would operate from this facility. Once operational, the groundwater well would provide up to 5 gallons of potable water per minute (during operations the O&M building is expected to use approximately 2,500 gallons of water per day for employee uses). A parking area for O&M staff and a graveled staging area would also be located within the fenced, access-controlled 5-acre site (a locked gate would control access to the site). Figure B-29, Tule Wind Project Typical Operations and Maintenance Facility Site, depicts the proposed O&M facility and Figure B-30, Tule Wind Project Profile Views of Typical Operations and Maintenance Building, provides profile views of the pre-engineered O&M building.

Figures B-20B and B-21B (Tule Wind Project) depict an access road that would be constructed off McCain Valley Road to provide access to the O&M facility.

To minimize the potential for glare on surrounding properties, the exterior of the O&M building would feature a low-reflectivity finish. Outdoor night lighting at the O&M facility would be kept to the minimum required for security and safety and all lighting would be turned off when not required. To minimize backscatter and off-site light trespass, all lighting would be hooded and directed downward.

B.4.1.5 Meteorological Towers and SODAR or LIDAR Unit

Location

~~Two~~ Three permanent MET towers would be installed within the McCain Valley National Cooperative Land and Wildlife Management Area to monitor wind speed and direction. Although only ~~two~~ three MET towers would be installed, the Tule Wind Project includes ~~two~~ three proposed and ~~two~~ three alternate tower locations (Figures B-19B, Tule Wind Project Overview, and B-20B, and B-21B, Tule Wind Project; proposed MET towers are depicted as PM-E1, ~~and~~ PM-W2, and PM-X1 while alternate MET towers are depicted as PM-E2, ~~and~~ PM-W1, and PMX21). Proposed towers PM-E1, and PM-W2, and PM-X1 would be freestanding lattice structures (approximately ~~197-219~~ to 328 feet tall) supported by concrete foundations. Proposed tower PM-E1 would be located approximately 0.5 mile northeast of the collector substation and O&M facility site, ~~while~~ PM-W2 would be located within the Lark Canyon Off-Highway Vehicle (OHV) Area, approximately 500 feet west of the proposed wind turbine G-11, and proposed tower PM-X1 would be located on the northwest ridge near proposed wind turbine L-6 (Figures B-19B, Tule Wind Project Overview, and B-20B, and B-21B, Tule Wind Project).

A permanent SODAR unit (approximately 9 feet tall, 6 feet wide, and 10 feet long) or a permanent LIDAR unit (approximately 3 feet tall, 3 feet wide, and 3 feet long) would also be installed on site. The SODAR or LIDAR unit would be located approximately 328 feet west of proposed MET tower PM-W2 within the Lark Canyon OHV Area.

The permanent concrete foundations associated with the proposed MET towers would result in approximately 900 square feet of permanent impacts per tower. Installation of the SODAR or LIDAR unit would also result in approximately 900 square feet of permanent impacts.

Description

As proposed, the MET towers would be approximately ~~200-219~~ to 328 feet tall, free standing (no guy wires), and would consist of three steel tube sections supported by a concrete foundation. A data logger located within a closed case at the base of the MET tower would transmit wind data to the O&M building. The MET towers would not be fenced. Lighting on the tower would be in compliance with, but would not exceed FAA lighting requirements (Advisory Circular (AC) 70/7460-1K: Obstruction Marking and Lighting).

The permanent SODAR unit would be capable of measuring the wind profile at heights of nearly 50 feet to more than 650 feet in 32-foot increments using pulses of sound. SODAR units are similar to RADAR except that sound waves (rather than radio waves) are used to analyze the wind. The SODAR unit would be housed in a trailer capable of being transported to the site by a truck (the trailer would be sited on a raised cement platform and fenced in to prevent

unauthorized access). The SODAR unit typically transmits data from a cell phone located in the trailer.

The permanent LIDAR unit, if installed instead of the SODAR unit, would be capable of measuring the wind profile at heights of from about 30 feet to more than 650 feet in 50-foot increments using pulses of infrared light. The LIDAR unit is cubic in shape, measures approximately 3 feet per side, and is about 45 kilograms in weight. The LIDAR is similar to RADAR except that infrared waves (rather than radio waves) are used to analyze the wind. The LIDAR would be housed on a small platform approximately 3 to 5 feet off the ground and would be located about 20 to 30 feet from the base of the permanent meteorology tower. The LIDAR unit typically transmits data from a cell modem as well as a local area network connection (Iberdrola Renewables 2011a).

Access roads would be constructed off McCain Valley Road and the G-turbine string access road to facilitate installation and maintenance of the proposed MET towers and SODAR or LIDAR unit (Figures B-19B, Tule Wind Project Overview, and B-21B, Tule Wind Project). Access roads to the proposed MET towers and SODAR or LIDAR unit ~~would~~ may be gated where they start along the main access road as determined necessary by BLM.

B.4.1.6 Overhead 138 kV Transmission Line

Location

An approximate ~~9.79~~2-mile-long 138 kV transmission line is proposed to be constructed from the collector substation to provide an interconnect to the rebuilt Boulevard Substation being proposed as part of SDG&E's ECO Substation Project (Figures B-2B, Vicinity/Overview Map, B-19B, Tule Wind Project Overview, and B-21B, and B-22B, Tule Wind Project). From the collector substation, the proposed 138 kV line would travel in a southeasterly direction for approximately 0.75 mile before turning south. The transmission line would then travel in a general southeasterly direction for approximately 4 miles before turning to the east for approximately 0.4 mile, and would then turn south again for approximately 3.0 miles. Along this segment, the transmission line would ~~span~~ cross I-8. South of I-8 the transmission line would turn west, travelling parallel with Old Highway 80 and would then enter the rebuilt Boulevard Substation where the line would terminate. Along the alignment, the proposed 138 kV transmission line would primarily traverse undeveloped land administered by the BLM and private land under the jurisdiction of the County of San Diego, with the exception of approximately ~~0.36~~26 linear miles of lands under the jurisdiction of the State of California (~~Conservation McCain Valley~~ Camp and Caltrans lands).

The new ~~9.79.2~~-mile, 138 kV overhead transmission line would require a 24-foot-wide temporary area of disturbance. Therefore, assuming a 24-foot-wide temporary area of disturbance, the transmission line would have a maximum temporary disturbance of ~~44.6-26.8~~ acres of land. In addition, ~~each of the 108~~approximately 80 transmission line poles supporting the proposed 138 kV line would require a 50-foot by 150-foot temporary area of disturbance, totaling ~~48.613.5~~ acres. Each pole would have an 8-foot-diameter permanent impact resulting in ~~0.42-09~~ acre of permanent impacts.

Description

The new ~~9.79.2~~-mile-long Tule Wind Project 138 kV transmission line would be supported by ~~108~~approximately 80 steel galvanized or weather steel finished ~~tangent~~ poles. Figure B-31A, Tule Wind Project Typical 138 kV Steel Tangent Pole, shows the single circuit 138 kV poles (the 138 kV transmission line would be constructed as either a single or double circuit pole), which would be approximately 75 feet high. Figures B-31B and B-31C show the double circuit poles under consideration by Tule Wind, LLC and the double circuit poles and would be similar in height as the single circuit poles (Iberdrola Renewables 2011d). constructed as a single circuit lacking any underbuild attachments. Minimum ground clearance of conductors would comply with the engineering specifications of 30 feet under final sag and a conductor temperature of 212 degrees Fahrenheit. Vertical clearance between conductors would be 12 feet and horizontal clearance would, at a minimum, exceed 12 feet. Although dependent on terrain, typical span lengths between poles would be 600 feet (maximum span lengths would be 700 feet). To protect the poles from lightning strike and to carry communication line, a fiber-optic shield wire would be installed at the top of each pole. ~~As required by SDG&E,~~ †The proposed transmission line and steel poles would be located within a ~~400~~125-foot ROW easement.

In order to connect the proposed 138 kV transmission line to the rebuilt Boulevard Substation, a cable pole and underground cable would be required. The cable pole would be approximately 40 feet higher (115 feet tall) than the 75-foot-tall poles supporting the 138 kV line along the majority of the alignment.

As shown in Figures B-19B, Tule Wind Project Overview, and B-21B, and B-22B (Tule Wind Project), access roads would be constructed to some steel pole locations for transmission line installation, inspection, and maintenance purposes. Where the transmission line is adjacent to existing roads, access would be facilitated through the use of existing roadways. Access roads would vary in width from 16 to 36 feet. During construction of the 138 kV transmission line, access is proposed from McCain Valley Road. The project does not propose new permanent access roads to the 138 kV transmission line.

B.4.1.7 Access Roads

Location

As shown on Figure B-19B, Tule Wind Project Overview, access roads would be constructed and improved primarily on BLM-administered land adjacent to proposed turbine strings in the In-Ko-Pah Mountains, near the McCain Valley. Additional access roads would be required to provide access to Rough Acres Ranch from Ribbonwood Road and Tule Wind, LLC Pacific Wind Development is seeking additional project access through the Manzanita and Campo Indian Reservations.

Description

In order to access proposed turbine and transmission pole locations and project facilities, and to facilitate the delivery of wind turbine components to the project area, existing roadways in the project area would be improved and new access roads would be constructed. Approximately ~~27.6~~23.4 miles of existing roadway would be improved and widened to 20 to 36 feet. In addition, approximately ~~36.4~~8 miles of new access roads would be constructed. In order to allow large cranes to move between turbines and turbine strings, temporary roads between turbine strings would be 36 feet wide. Remaining access roads would be ~~20-18 to 24~~ 18 to 24 feet wide, depending upon jurisdiction. Total land requirements for new and improved access roads would be approximately ~~250.3~~236.1 acres (83.5 acres of temporary impacts and 152.6 acres of permanent impacts).

Upon completion of construction activity, existing and proposed access roads located on land under the jurisdiction of the County of San Diego will be improved to comply with the Department of Public Works Private Road Standard of 24 feet (28-foot-graded extent). The main project roads (Ribbonwood Road and McCain Valley Road) throughout the project site will be improved to a maximum of 20 feet to comply with the California Fire Code Standards. Spur roads to the turbines will be improved to a maximum of 18 feet wide to comply with State Responsibility Areas (SRA) Fire Safe Regulations. As determined necessary by BLM, All new permanent spur access roads ~~would~~may be gated off the main access road to prevent unauthorized excessive motor vehicle intrusions. Proposed new access roads and existing access roads to be improved are shown on Figures B-20 through B-22 (Tule Wind Project).

B.4.2 Tule Wind Project Construction

This section presents an overview of construction methods typically used for installation of new wind turbines, construction of a new collector substation, installation of overhead transmission lines, and construction of new pole structures.

B.4.2.1 Construction Schedule

Construction of the proposed Tule Wind Project is anticipated to require 2 years to complete. Table B-9, Proposed Tule Wind Project Construction Schedule, provides ~~Tule Wind, LLC Pacific Wind Development~~'s proposed schedule for the Tule Wind Project, as defined in its Applicant's Environmental Document (Iberdrola Renewables, Inc. 2010). While the schedule would be modified to begin after BLM, Bureau of Indian Affairs, County of San Diego, and CSLC approval, this table illustrates the approximate duration of major project activities.

**Table B-9
Proposed Tule Wind Project Construction Schedule**

Project Activity	Completion Dates
ROD	December 2010 June 2011 2010
Acquisition of additional required permits	December 2010 through March 2011 November 2011
ROW/property acquisition	December 2010 April 2011
Construction begins	December 2010 1
Completion of construction	June-October 2012
Project operational ¹	November 2012
Punch list/clean up	January 2013

Source: Iberdrola Renewables, Inc. 2010~~2011a~~.

¹"Continuous full-load operation cannot occur until the ECO Substation Project is complete."

~~Tule Wind, LLC Pacific Wind Development~~ anticipates that construction activities would occur between 7 a.m. and 7 p.m., Monday through Saturday, but may involve extended hours as needed to complete certain construction activities.

B.4.2.2 Construction Activities and Methods

In order to facilitate construction, temporary workspace would be required for some project components. Table B-8, Summary of Tule Wind Project Components, provides the anticipated workspace/land requirements. In addition to the areas identified in Table B-8, a 10-acre temporary parking area and 5-acre temporary concrete batch plant would be required during construction. These facilities are located to the south of the proposed G-turbine strings on private BLM jurisdictional lands. Figures B-19B, Tule Wind Project Overview, B-20B, B-21B, and B-22B (Tule Wind Project) illustrate the anticipated laydown areas for the Tule Wind Project (Figures B-19B and B-22B identify the location of the temporary parking area and concrete batch plant). ~~As illustrated in Table B-8, temporary workspace would not be required for construction of the collector substation, O&M facility, MET Towers, and SODAR or LIDAR Unit, 138 kV overhead transmission line, and access roads.~~

During construction, temporary security fencing (6-foot-tall chain-link fencing ~~with security wiring at the top~~) ~~would~~ may be located around all staging and laydown areas, storage yards, and excavation areas to limit public access. When construction is complete, fencing would be removed and staging areas would be returned to their pre-construction state. The temporary staging and work areas identified for specific project components are described as follows.

Wind Turbines

Site Preparation

A 2-acre laydown area would be located at one end of each turbine string during construction. As shown on Figure B-19B, Tule Wind Project Overview, approximately 19 2-acre laydown areas would be located in the project area to support construction of the wind turbines. These areas would be cleared and during construction, laydown areas ~~would be~~ may be fenced and gated to control access and to minimize theft.

A temporary workspace would be cleared for each wind turbine tower. Each workspace would require up to a 200-foot radius to be cleared and leveled. The cleared area would be necessary for foundation excavation and construction, and turbine assembly. The construction crane used to hoist turbine components into place would be staged within the cleared workspace. A typical turbine site is depicted on Figure B-23, Tule Wind Project Typical Turbine Site.

Foundation Construction

The design of the turbine foundation would be determined by site-specific geotechnical investigations at each turbine site. During investigations, soil borings would be collected at each proposed turbine location to ensure sufficient soil-bearing capacity. Investigations would be performed by a licensed geotechnical engineer capable of analyzing each location and recommending specific construction techniques for foundational strength at each tower. Once the soil-bearing capacity of each site is analyzed and foundation recommendations are made, the soil would be excavated and reinforced concrete foundations would be placed according to the manufacturer's and geotechnical engineer's recommendations. Construction of the ~~element~~ concrete turbine foundations (134128) would require between 7,500 and 15,000 gallons of water ~~each per foundation, with up to two foundations constructed per day, totaling between 960,000 and 1,005,000 and 2,010,000 gallons to construct foundations for all 128 turbines.~~

Preliminary engineering incorporating critical geotechnical, climatologic, and mechanical factors indicates that several foundations types are feasible and may be incorporated into the construction of the turbine foundation:

- **Spread Footing.** Preliminary engineering concludes that spread footings should typically be acceptable footing types. A level foundation subgrade is, however, difficult to achieve in

bedrock and the use of lean concrete and engineered fill is often needed to level the bedrock subgrade to facilitate construction of the spread footing.

- **Rock Socket Foundation.** This foundation may be appropriate and feasible at sites where bedrock is encountered at very shallow depths (within 1-3 feet of the ground surface). Each individual turbine site should be evaluated accordingly. Construction of this foundation is initiated by blasting an excavation area of approximately 20 feet by 20 feet by 20 feet into the bedrock. An anchor bolt cage is then placed to reinforce the excavation, and the excavation is filled with concrete. Rock strength, rock conditions, and blasting techniques often dictate the success of this foundation type.
- **Rock Anchor Foundation.** A rock anchor foundation may be appropriate and feasible at sites where strong, massive bedrock is encountered at very shallow depths (within 1-3 feet of the ground surface). Construction of this foundation is initiated by blasting an excavation area approximately 25–35 feet in diameter by 7–9 feet into the bedrock. Anchors are then drilled to an approximate depth of between 20–50 feet, an anchor bolt cage is placed to reinforce the excavation, and a concrete cap is poured. Rock strength, rock conditions, and blasting techniques often dictate the success of this foundation type.
- **Patrick and Henderson (P&H) Style Foundation.** P&H-style caissons have been constructed in similar soil and rock conditions found at the Tule Wind Project site. The P&H style foundation is occasionally known to have issues with foundation movement and is considered feasible to construct at the project site.

Permanent wind tower foundations would be approximately ~~60-40~~ to 80 feet in diameter, and 7 to 10 feet deep (exact dimensions would depend on specific site needs). Once the soil has been excavated and compacted, turbine tower foundations would be constructed of structural concrete and appropriate steel reinforcement would be applied as directed by the tower manufacturer. Each concrete foundation would incorporate approximately 250 to 500 CY of concrete. Each turbine foundation ~~would~~ may also include a 5-foot by 9-foot concrete pad ~~if for the turbine utilizes a pad-mounted transformer.~~ Each concrete foundation pad would incorporate approximately 275 to 707 CY of concrete.

Aboveground Equipment Installation

Wind turbine components would be transported to each proposed turbine location. Turbine tower sections, rotor assembly, and the nacelle would be lifted into place by a construction crane. To support the construction crane during turbine erection, a compacted-soil crane pad (40 feet by 120 feet with a maximum slope of 1%) would be required at each turbine location. Along with underlying soils, the crane pad would be compacted to provide ~~a minimum~~ the soil-bearing capacity of ~~6,000 pounds per square foot in order~~ necessary to provide a stable foundation for the

crane. The site would be leveled by blasting (if necessary) and grading. Where the site topography precludes such methods from achieving a 1% slope a crane mat would be used, instead of a crane pad, to achieve the 1% slope.

Post-Construction Restoration

After the turbine has been erected, the area surrounding the base of the turbine tower would be gravel-surfaced to a distance of between 9 and 10 feet. Gravel would be used to provide a stable surface for maintenance vehicles and to minimize surface erosion and runoff.

Once construction is complete, laydown areas would be revegetated to their natural state.

Overhead and Underground 34.5 kV Collector Cable System

The underground portion (approximately ~~29~~35.1 miles) of the collector cable system would require a 24-foot temporary ROW and would be placed in a ~~42~~44- to 50-inch-deep and 12-inch-wide trench that would be constructed generally along the length of the proposed turbine access roads. Each three-phase cable trench would be separated from all other cable trenches by a minimum of 10.5 feet (the remainder of the trench would be backfilled with excavated soil in 12-inch lifts and compacted to near-original density). The topsoil from trench excavation would be set aside before the trench is backfilled and would ultimately comprise the uppermost layer of the trench. In rocky areas, blasting may be required prior to excavation of the trench. When work would occur in the proximity of sensitive habitat, blasting would only occur within specific timeframes and at specific distances.

Installation of the underground 34.5 kV collector cable system would temporarily impact ~~84~~299.8 acres of land.

Collector Substation

Site Preparation

Once access to the collector substation site has been constructed, site grading would follow. Site grading would require the use of bulldozers and scrapers in order to cut and fill native soil to the proposed pad elevation. The site would be fenced with chain-link security fencing to minimize the potential for non-authorized entry.

Site preparation would also include construction of drainage components to capture and direct stormwater flow across the site.

Foundation Construction

Foundation construction would begin once the site is cleared and graded. Equipment including backhoes and drill rigs would be used to excavate foundations. Concrete would be used to build the foundation/substation pad.

Aboveground Equipment Installation

Once the substation pad has been established, installation of aboveground equipment would begin. Construction would generally consist of installing of electric transformers, breakers, switches, and other electrical components. Equipment installation would be accomplished by delivering equipment to the site on trucks and lifting it into place using cranes.

Post-Construction Restoration

Areas of the collector substation not covered with concrete would be graveled to minimize surface runoff and erosion and for fire protection.

Operations and Maintenance Facility

Site Preparation

The 5-acre O&M facility site would be cleared. During construction the site ~~may~~would be fenced and gated to control access and to limit theft of stockpiled material and equipment. The O&M facility site access road would be graded in order to facilitate access to the O&M building. In addition, the on-site staging area would be graveled.

Foundation Construction

The O&M building would require construction of concrete foundation. The pre-engineered building would be erected on site. Individual components, such as columns, beams, siding, and roofing, would be shipped to the site.

Post-Construction Restoration

As stated above, the entire 5-acre site would be cleared. Except for a few ornamental trees, the site would remain cleared during operations.

Meteorological Towers

Prior to site preparation, access roads to each proposed MET tower would be constructed. Once access has been established, proposed MET tower locations would be cleared and graded. Excavation of the tower foundation would begin shortly thereafter. In order to support the tower a concrete foundation measuring approximately 25 feet by 25 feet would be required. Once the

tower foundation has been established, the tower sections would be assembled and the tower would be lifted into place ~~by a gasoline-powered winch.~~

Overhead 138 kV Transmission Line

Site Preparation

The new 138 kV transmission line would require a ~~100~~125-foot ROW. All temporary and permanent impacts would occur within this ROW. Access to each steel pole location would be constructed prior to clearing activities. Once access has been established, a temporary work area measuring 50 feet by 150 feet around each steel pole location would be cleared of vegetation. Construction activities associated with the overhead 138 kV transmission are anticipated to result in temporary impacts to ~~44.6~~40.3 acres of land.

Transmission Line Pole~~Foundation~~ Construction

Each transmission line pole ~~foundation~~ would be direct buried, with maximum hole dimensions of 8 feet wide by 25 feet deep. Pole ~~foundations~~-holes would be excavated using a truck-mounted drill rig and poles would then be delivered on a flat-bed trailer and hoisted into place by a crane. The annular space between poles and holes would then be backfilled soil or with concrete. Any remaining excavated material would be placed around the holes or spread onto access roads and adjacent areas.

Aboveground Equipment Installation

Each pull-and-tension site would use an area measuring approximately 150 feet by 100 feet. Seven conductor-pulling sites with one at each end of the line and five in between at the major double dead-end line angles are anticipated to be required for the installation of the 138 kV transmission line.

Stringing of the transmission line would be done in a similar manner as described for the ECO Substation Project 138 kV transmission line component.

Access Roads

Due to turbine size and heavy turbine components, existing roadways would be widened to accommodate large trucks and cranes. Bulldozers and graders would be used to widen roads and a water truck would be used for road compaction and dust control. Temporary roads between turbine sites would be constructed to 36-foot widths in order to accommodate larger vehicles. Depending on the subsurface soil characteristics present on site, soils may need to be excavated and replaced with gravel and/or sand to provide a stable road base. Construction of roads on slopes greater than 10% would be avoided and roads would be located away from drainage

bottoms, wetlands, and erodible soils. Roads would be designed to prevent soil erosion and maintain existing surface water runoff patterns.

Concrete Batch Plant

During construction, a temporary 5-acre ~~cement~~ concrete batch plant would be located approximately 5 miles southeast of the collector substation, near the southern extent of the proposed G-turbine string, near Rough Acres Ranch (Figures B-19B, Tule Wind Project Overview, and B-22B, Tule Wind Project). The batch plant is necessary to mix concrete for the foundations of the turbine towers, collector substation, and the O&M facility. Sand, aggregate, and concrete ~~would~~ could be sourced from existing local and permitted quarries. After being delivered to the batch plant ~~via truck~~, the aggregate and sand would be placed into stockpiles. Cement, obtained from ~~nearby off-site~~ vendors, could also be delivered by truck and stored in silos. Approximate quantities for raw materials necessary for each proposed turbine would include 350,000 to 700,000 ~~375,900~~ pounds of sand; 475,000 to 950,000 ~~572,100~~ pounds of aggregate; and 200,000 to 400,000 ~~168,300~~ pounds of cement (Iberdrola Renewables 2011a)~~Pacific Wind Development 2009~~).

The batch plant would consist of a mixing plant, areas for aggregate and sand stockpiles, driveways, truck load-out area, and turnaround. The batch plant would include cement storage silos, water and mixture tanks, aggregate hoppers, and conveyors and augers to deliver different materials to the mixing plant. Water from wells ~~drilled~~ identified by the project applicant ~~in close proximity to the temporary cement concrete batch plant~~ would be used during construction activities. The batch plant equipment is portable and would be removed once construction is complete and the site would be recontoured and revegetated.

Additional Parking Areas

In addition to the workspaces associated with the main project components discussed previously, the project is proposing a temporary 10-acre parking area on ~~Rough Acres Ranch~~ BLM jurisdictional lands (Figures B-19B, Tule Wind Project Overview, and B-22B, Tule Wind Project). This area would be used for construction trailers, vehicle parking, and equipment laydown. The parking areas would be graded.

B.4.2.3 Construction Personnel and Equipment

Construction of the Tule Wind Project would employ up to 325 workers per day during the peak construction period. Depending on the specific stage of construction, an average daily ~~peak~~ workforce of 125 workers would be present at the construction site and up to 200 delivery trucks are anticipated. During the peak of construction, a typical day would include the transportation of turbines, movement of heavy equipment, and transportation of materials and

concrete. Construction activities ~~would~~ may be supplied power by generators provided by the construction contractor.

Table B-10, Construction Equipment Associated with the Tule Wind Project, lists construction equipment commonly associated with the construction of wind facilities.

Table B-10
Construction Equipment Associated with the Tule Wind Project

Equipment	Use
Bulldozer	Road and pad construction
Grader	Road and pad construction
Water trucks	Compaction, erosion, and dust control
Roller/compactor	Road and pad compaction
Backhoe/trenching machine	Digging trenches for underground utilities
Excavator	Foundation excavation
Heavy duty rock trencher	Underground trenching
Truck-mounted drill rig	Drilling power pole holes
Concrete trucks/concrete pumps	Pouring tower and other structure foundations
Cranes	Tower/turbine hoisting
Dump trucks	Hauling road and pad material
Flatbed and low bed trucks	Hauling turbine towers, turbines, components, and construction equipment
Pickup trucks	General use and hauling of minor equipment
Small hydraulic cranes/forklifts	Loading and unloading equipment
Four-wheel drive all terrain vehicles	Rough grade access and underground cable installation
Rough terrain cranes/forklifts	Lifting equipment and pre-erection assembly

Source: Pacific Wind Development 2009.

The use of helicopters for delivery of equipment to remote areas is not proposed.

B.4.2.4 Water Usage

~~Tule Wind, LLC Pacific Wind Development~~ has identified three existing groundwater wells (well 6a located on Rough Acres Ranch and the North and Thing Valley wells located on the Ewiiapaayp Reservation) as potential sources of water for use during construction (Iberdrola Renewables 2010, 2011b, 2011c). Additional potential sources of water available locally include the Jacumba Community Services District and the Live Oak Springs Water Company, ~~and McCain Valley Conservation Camp.~~

Construction of the Tule Wind Project is estimated to require approximately 17,512,000 19 million gallons of water to support the water needs of the project for dust suppression and concrete mixing. ~~Project water needs are currently expected to be supplied by a combination of~~

~~on-site wells and nearby water districts. The project has received written confirmation from the Jacumba Community Service District (Lindenmeyer 2010) and Live Oak Spring Water Company (Najor 2010) of water supplies available to provide construction water to the project. The project may also receive water from McCain Valley Conservation Camp. Wells located on Rough Acres Ranch would also supply water for construction of the Tule Wind Project (Iberdrola Renewables, Inc. 2010). Approximately 250,000 gallons of water per day over a period of 60 to 72 days is anticipated to be needed for dust suppression and for construction while turbine construction and road construction activities would be conducted simultaneously. Project water needs are currently expected to be supplied by a combination of on-site wells, and if necessary would be augmented with water from nearby water districts. Wells located on Rough Acres Ranch and in Thing Valley on the Ewiiapaayp Reservation that, when combined, well testing has shown can produce approximately 130 gpm, would supply water for construction of the Tule Wind Project (Geo-Logic Associates 2010). The project has received written confirmation from the Jacumba Community Service District (Lindenmeyer 2010) and Live Oak Spring Water Company (Najor 2010) of water supplies available to provide construction water to the project. In addition, the property owners of the well sites on Rough Acres Ranch and Ewiiapaayp tribal lands provided letters confirming use of the wells by Tule Wind, LLC during construction of the Tule Wind Project (Iberdrola Renewables 2011b, 2011c). This would require approximately 60 truck trips per day to supply water assuming a truck capacity of 4,000 gallons. When turbine and road construction activities would not be occurring simultaneously, the project is expected to require a maximum of 30 truck trips per day to supply water. Where on-site wells can supply water, truck trips would be reduced.~~

B.4.3 Tule Wind Project Operations and Maintenance and Decommissioning

Operation and maintenance of the Tule Wind Project would require up to 12 full-time employees. These workers would typically be present on site during normal business hours and would work out of the O&M building. The collector substation would be unmanned during operations. Unauthorized entry into the O&M facility and substation would be prevented through the provision of security fencing and locked gates. The SODAR unit trailer would also be locked in order to prevent unauthorized access. As stated previously, the O&M building site will include a groundwater well to provide up to 5 gallons per minute of potable water. Once the project is operational, the O&M facility will use approximately 2,500 gallons of water per day for employees' water and sewer uses. The site will also include a septic system.

A SCADA system would be installed at the project in order to collect operating and performance data from the wind turbines. The SCADA system would also allow for remote operation of the wind turbines from the O&M facility, or from anywhere an authorized user could access the internet.

Wind Turbines

Each turbine would be serviced approximately twice per year, or as needed. Typical service activities include (but are not limited to) temporarily deploying a crane within the construction easement of each turbine, removing the turbine rotor, replacing generators, bearings, and deploying personnel to climb the towers to service parts within the turbine. In addition, computer systems inside each turbine would routinely perform self-diagnostic tests. The installed computer systems would allow a remote operator to set new operating parameters, perform system checks, and ensure turbines are operating at peak performance.

As a safety precaution, turbines would automatically shut down if sustained winds or gusts exceed predetermined set points established by the turbine manufacturer to prevent equipment failure~~reach 50 mph or gusts reach about 56 mph~~. Inoperative turbines would be repaired, replaced, or removed in a timely manner.

Overhead and Underground 34.5 kV Collector Cable System

The overhead and underground 34.5 kV collector cable system would be regularly inspected, maintained, and repaired following construction. Overhead components would be inspected ~~annually~~, at a minimum, for corrosion, equipment misalignment, loose fittings, and other mechanical problems. The underground portion of the cable system would be inspected ~~annually from inside the concrete vaults~~ as required. ~~Tule Wind, LLC~~ Pacific Wind Development would maintain a working space around all overhead structures, which would be cleared of shrubs and other obstructions for inspection and maintenance purposes.

Collector Substation

During operations, O&M staff would visit the substation several times a week for switching and other operations activities. On a regular basis (weekly, monthly, yearly) construction and maintenance trucks would visit the substation to perform routine maintenance including (but not limited to) equipment testing, monitoring, and repair, routine procedures to ensure service continuity, and standard preventative maintenance.

Overhead 138 kV Transmission Line

Maintenance and repair activities for the overhead 138 kV transmission line would be similar to those being proposed for the ECO Substation 138 kV transmission line. Activities include both routine preventive maintenance and emergency procedures conducted to maintain system integrity, as well as vegetation clearing.

Access Roads

In order to evaluate road use, minimize traffic volume, and ensure that roads are adequately maintained, ongoing transportation planning would be conducted throughout the operational phase of the Tule Wind Project.

Decommissioning

Prior to the termination of the ROW authorization (~~Tule Wind, LLC~~~~Pacific Wind Development~~ is requesting a minimum 30-year ROW grant to construct and operate the Tule Wind Project), a final decommissioning plan would be developed in compliance with the standards and requirements for closing a site and would be circulated for approval by interested agencies. The ROW grant could potentially be renewed by ~~Tule Wind, LLC~~~~Pacific Wind Development~~; however, according to CFR 43 2805.15, the BLM retains the right to determine whether the ROW grant is renewable. If the applicant desires to renew the ROW, the applicant would submit an application, and BLM would review the application and make a decision based on the applicable federal laws and regulations in place at that point in time.

A site reclamation plan and monitoring program would be included as components of the decommissioning plan. Requirements in effect at the time of decommission are anticipated to require that all turbines and ancillary structures be removed from the site. The final decommissioning plan would, however, be developed in compliance with the standards and requirements for closing a site at the time decommissioning occurs.

When the facility is retired or decommissioned, the turbine towers would be removed from the site and the materials would be reused or sold for scrap. Decommissioning activities are anticipated to have similar types of construction-related activities and therefore, all procedures, management plans, and BMPs developed for the construction phase of the project would be applied to the decommissioning phase of the project.

~~Tule Wind, LLC~~~~Pacific Wind Development~~ would implement a habitat restoration plan once project facilities have been removed and the project site is returned to pre-construction and operation conditions. Topsoil from all decommissioning activities would be salvaged and reapplied during final reclamation and all areas of disturbed soil would be reclaimed using weed-free native shrubs, grasses, and forbs.

According to BLM Instructional Memorandum 2009-043, a bond is required for all development (ROW) grants to ensure compliance with the terms and conditions of the ROW authorization and the requirements of applicable regulatory requirements (BLM 2008). The amount of the bond would include potential reclamation and administrative costs to BLM. A minimum bond amount, considering salvage values of turbines and towers, will be required for all wind energy

development projects on public lands. The amount of the required bond will be determined during the ROW authorization process based on site-specific and project-specific factors. All bonds will be periodically reviewed (at least every 5 years) by the BLM authorized officer to ensure adequacy of the bond.

The decommissioning plan would also be provided to the County of San Diego, which also may require a bond to ensure decommissioning of the project on County lands.

B.4.4 Tule Wind Project Applicant Proposed Measures

APMs provided by Tule Wind, LLC~~Pacific Wind Development~~ are listed by subject in Table B-11, Tule Wind Project Applicant Proposed Measures for Each Issue Area. Table B-12, Tule Wind Project Applicant Proposed Measures, lists the APMs as proposed by Tule Wind, LLC~~Pacific Wind Development~~.

Table B-11
Tule Wind Project Applicant Proposed Measures for Each Issue Area

Issue Area	Applicable APMs
Aesthetics	TULE-AES-1 through TULE-AES-144
Air Quality	TULE-AIR-1 through TULE-AIR-18
Biological Resources	TULE-BIO-1 through TULE-BIO-11
Cultural Resources	TULE-CUL-1 through TULE-CUL-5
Fire and Fuels Management (APMs are referred to as Project Design Features, PDFs)	TULE-PDF-1 through TULE-PDF-26
Hazards and Hazardous Materials	TULE-HAZ-1 through TULE-HAZ-3
Hydrology and Water Quality	TULE-HYD-1 through TULE-HYD-5
Noise	TULE-NOI-1 through TULE-NOI-16
Public Health and Safety	TULE-PHS-1 through TULE-PHS-8
Recreation and Wilderness	TULE-REC-1 through TULE-REC-2
Traffic and Transportation	TULE-TRAF-1 through TULE-TRAF-3

Table B-12
Tule Wind Project Applicant Proposed Measures

APM No.	Description
TULE-AES-1	Use of wind turbine towers, nacelles, and rotors that are locally uniform and that conform to high standards of industrial design to present a trim, uncluttered, aesthetic appearance.
TULE-AES-2	Use of low-reflectivity, neutral white finishes for the towers, nacelles, and rotors to minimize contrast with the sky backdrop and to minimize the reflections that can call attention to structures in the landscape.
TULE-AES-3	Use of neutral gray, white, off-white, or earth tone finishes for the small cabinets containing pad-mounted equipment that might be located at the base of each turbine, to help the cabinets blend into the surrounding ground plane.

Table B-12 (Continued)

APM No.	Description
TULE-AES-4	Restriction of exterior lighting on the turbines to the aviation warning lights required by the FAA, which will be kept to the minimum required number and intensity to meet FAA standards.
TULE-AES-5	Placement of much of the Facility's electrical collection system underground (as much as possible), minimizing the system's visual impacts.
TULE-AES-6	Use of a low-reflectivity finish for the exterior of the O&M facility building to maximize its visual integration into the surrounding landscape.
TULE-AES-7	Restriction of outdoor night lighting at the O&M facility and the substation to the minimum required for safety and security; sensors and switches will be used to keep lighting turned off when not required, and all lights will be hooded and directed to minimize backscatter and offsite light trespass. In keeping with the San Diego County Dark Skies Ordinance, Class II lamp source and shielding requirements will be used to illuminate walkways, roadways, equipment yards, parking lots and outdoor security. Fully shielded low pressure sodium lighting will be used on outdoor fixtures to reduce or eliminate detrimental lighting impacts to nearby Astronomical Observatories.
TULE-AES-8	Use of a low-reflectivity finish for substation equipment to minimize its visual salience.
TULE-AES-9	Use of dull gray porcelain insulators to reduce insulator visibility.
TULE-AES-10	Use of fencing with a dull finish around the substation to reduce the fence's contrast with the surroundings.
TULE-AES-11	Avoid trees to the extent practical.
<u>TULE-AES-12</u>	<u>The public shall be involved and informed about the visual site design elements of the proposed wind energy facilities. Possible approaches include conducting public forums for disseminating information, offering organized tours of operating wind developments, and using computer simulation and visualization techniques in public presentations.</u>
<u>TULE-AES-13</u>	<u>Turbine arrays and turbine design shall be integrated with the surrounding landscape. Design elements to be addressed include visual uniformity, use of tubular towers, proportion and color of turbines, non-reflective paints, and prohibition of commercial messages on turbines.</u>
<u>TULE-AES-14</u>	<u>Other site design elements shall be integrated with the surrounding landscape. Elements to address include minimizing the profile of the ancillary structures, burial of cables, prohibition of commercial symbols, and lighting. Regarding lighting, efforts shall be made to minimize the need for and amount of lighting on ancillary structures.</u>
TULE-AIR-1	The construction contractor(s) shall adhere to all San Diego County Air Pollution Control District (APCD) Rules and Regulations.
TULE-AIR-2	Compliance with SDAPCD Rule 55 for fugitive dust and SDAPCD Rule 61 for handling VOCs shall reduce NOx, and PM ₁₀ and PM _{2.5} emissions during construction.
TULE-AIR-3	Implementation of active dust suppression measures during the construction period to minimize the creation of dust clouds; including, but not limited to: applying water at least once per day, or conduct watering as necessary to prevent visible dust emissions from exceeding 100 feet in length in any direction. Increase watering frequency to four times per day if winds exceed 25 mph. Non-toxic soil stabilizers may be utilized to control fugitive dust.
TULE-AIR-4	Restrict construction vehicle speeds to 20 miles per hour (MPH) on unpaved roads.
TULE-AIR-5	Construction workers will be encouraged to carpool to the job site.
TULE-AIR-6	Construction vehicles and equipment will be limited to a maximum of five minutes idling time, when not performing required tasks. Certain vehicles, such as large diesel-powered vehicles, have extended warm-up times following start-up that limit their availability for use following start-up. Where such diesel powered vehicles are required for repetitive construction tasks, these vehicles may require more idling time.
TULE-AIR-7	Heavy-duty diesel equipment engines shall be properly tuned and maintained in compliance with State of California emissions regulations to ensure minimum emissions under normal operation. Construction contractors shall implement this measure to the extent practical.

Table B-12 (Continued)

APM No.	Description
TULE-AIR-8	Use low-emission construction equipment. The construction contractor(s) shall maintain construction equipment per manufacturing specifications and use low-emission equipment. The construction contractor(s) shall substitute small electric-powered equipment for diesel and gasoline-powered construction equipment where feasible.
TULE-AIR-9	Apply soil stabilizers to construction areas not being utilized.
TULE-AIR-10	Prepare and implement a high wind dust control plan.
TULE-AIR-11	Stabilize previously disturbed areas if subsequent construction is delayed.
TULE-AIR-12	Replace ground cover in disturbed areas as soon as feasible.
TULE-AIR -13	Require 90-day low-NO _x tune-ups for construction equipment.
TULE-AIR-14	Utilize diesel particulate filter on heavy equipment where feasible.
TULE-AIR -15	Vehicles hauling dirt or fill shall be covered with a tarp or by other means.
TULE-BIO-1	<i>Management of Temporary Stockpiles.</i> Temporary stockpiles outside the channels or debris basins will be stabilized by compacting or other measures if present at the work site from 1 December to 1 April. Silt fences, berms, or other methods will be used to prevent sediments from being eroded from the temporary stockpile into the adjacent drainage. Temporary stockpiles may be placed in channel bottoms or debris basins if they are located on barren soil or areas with non-native weeds, and are not placed in such a manner that they are exposed to flowing water. No temporary stockpiles will be placed on the channel bed or banks during the period of 1 December to 1 April for more than the duration of the sediment removal work. Permanent stockpiles will be located landward of the 100-year floodplain to the maximum extent feasible.
TULE-BIO -2	<i>Minimization of Disturbance to Vegetation in Channel Bottom.</i> Iberdrola Renewables will minimize vegetation removal or reduction from channel bottoms to the least amount necessary to achieve the specific maintenance objectives for the reach. Vegetation removal in the channel bottom will be conducted in a non-continuous manner, allowing small patches of in-channel vegetation to persist provided it will not adversely affect conveyance capacity.
TULE-BIO-3	<i>Road Base Discharge Avoidance.</i> Iberdrola Renewables will implement measures to prevent the discharge of road base, fill, sediments, and asphalt beyond a previously established road bed when working adjacent to channels and basin bottoms.
TULE-BIO-4	<i>Habitat Restoration.</i> Iberdrola Renewables will restore native vegetation in the affected work areas after construction. Restoration will include planting or seeding native plants that were present prior to the work and/or are compatible with existing vegetation near the work area. Iberdrola Renewables will prepare a restoration plan for the project that specifies the limits of restoration, planting mix and densities, performance criteria for survival and growth, and maintenance and monitoring procedures.
TULE-BIO-5	<i>Concrete Wash-Out Protocols.</i> Iberdrola Renewables will implement appropriate waste management practices during on site concrete repair operations. Waste management practices will be applied to the stockpiling of concrete, curing and finishing of concrete as well as to concrete wash-out operations. Waste management practices will be adequate to ensure that fluids associated with the curing, finishing and wash-out of concrete will not be discharged to the channel or basin. Concrete wastes will be stockpiled separately from sediment and protected by erosion control measures so that concrete dust and debris are not discharged to the channel or basin. The appropriate waste management practices based on considerations of flow velocities, site conditions, availability of erosion control materials and construction costs will be used.
TULE-BIO-6	<i>Management of Fuels and Avoidance of Spills and Leaks.</i> All fuels, waste oils, and solvents will be collected and stored in tanks or drums within a secondary containment area consisting of an impervious floor and bermed sidewalls capable of holding the volume of the largest container stored within. Iberdrola Renewables will ensure that all equipment operating in or near a drainage, or in a basin, is in good working condition, and free of leaks. All vehicles will have drip pans during storage to contain minor spills and drips. No refueling or storage will take place within 100 feet (30.5 meters) of a drainage channel or structure. Spill containment materials must be on site or readily available for any equipment maintenance or refueling that occurs adjacent to a drainage. In addition, all maintenance crews working with heavy equipment will be trained in spill containment and response.

East County Substation/Tule Wind/Energia Sierra Juarez Gen-Tie Projects
B. PROJECT DESCRIPTION

Table B-12 (Continued)

APM No.	Description
TULE-BIO-7	<i>Prevention of Erosion and Sedimentation.</i> Design measure such as straw wattles, silt fencing, aggregate materials, wetting compounds, and revegetation of native plant species will be implemented to decrease erosion and sedimentation.
TULE-BIO-8	<i>Work Cessation during Heavy Rains.</i> All <u>earthwork/disruptive heavy equipment</u> will cease during heavy rains, and will not resume until conditions are suitable for the movement of equipment and materials. <u>However, work inside towers, nacelles, etc., will continue.</u>
TULE-BIO-9	A qualified biologist will regularly monitor construction activities to ensure construction is proceeding in compliance with Iberdrola Renewables proposed environmental mitigation measures as well as those measures required by the regulatory agencies.
TULE-BIO-10	Iberdrola Renewables will develop an environmental training program for its construction contractors and personnel. The environmental training will cover the sensitive resources found on-site, flagging/fencing of exclusion areas, permit requirements, and other environmental issues. All construction site personnel will be required to attend the environmental training in conjunction with hazard and safety training prior to working on site.
TULE-BIO-11	A monitoring program would be implemented to ensure environmental conditions are monitored during the operation and decommissioning phases (Iberdrola Renewables 2010). The monitoring program would include adaptive management strategies to reflect improved technology or the need to adjust to a better understanding of the data during the actual impacts of the project.
TULE-BIO-12	Nighttime vehicle traffic volume associated with project activities will be kept to a minimum and speeds will be limited to 10 mph to prevent mortality of nocturnal wildlife species.
TULE-BIO-13	At the completion of the project, all construction materials will be removed from the site.
TULE-BIO-14	Except when not feasible due to physical or safety constraints, all project vehicle movement will be restricted to existing access roads and access roads constructed as a part of the project and determined and marked by the project proponent in advance of construction. Approval from a biological monitor will be obtained prior to any travel off of existing access roads.
TULE-BIO-15	During construction and operation of the proposed project, measures will be taken to avoid/minimize the impact of light intrusion into adjacent native habitat. The BLM Final Programmatic Environmental Impact Statement on Wind Energy Development on BLM-Administered Lands in the Western U.S. recommends the following: <ul style="list-style-type: none"> • Night lighting during construction would not occur to the maximum extent practicable; • Any night lighting during construction and operation would be selectively placed, shielded, and directed away from all areas of native habitat to the maximum extent practicable; and • All unnecessary lighting should be turned off at night to limit attracting migratory birds.
TULE-BIO-16	The construction contractor(s) shall adhere to all San Diego County Air Pollution Control District (SDAPCD) Rules and Regulations. Compliance with SDAPCD Rule 55 shall reduce fugitive dust during construction.
TULE-BIO-17	Implementation of active dust suppression measures during the construction period to minimize the creation of dust clouds; including, but not limited to: applying water at least once per day, or conduct watering as necessary to prevent visible dust emissions from exceeding 100 feet in length in any direction. Increase watering frequency to four times per day if winds exceed 25 mph. Non-toxic soil stabilizers may be utilized to control fugitive dust.
TULE-BIO-18	Restrict construction vehicle speeds to 20 mph on unpaved roads.
TULE-BIO-19	Apply soil stabilizers to construction areas not being utilized and stabilize disturbed areas if subsequent construction is delayed.
TULE-BIO-20	Replace ground cover in disturbed areas as soon as feasible.
TULE-BIO-21	Prior to any blasting east of McCain Valley Road biological monitors would confirm that no peninsular bighorn sheep were present within one-third of a mile of the area designated for blasting, in order to avoid harassment or disturbance impacts from blasting. If sheep are present and blasting cannot wait for a time when they have left the area then a temporary sound barrier will be erected to reduce the impacts on sheep habitat.

Table B-12 (Continued)

APM No.	Description
TULE-CUL-1	For each cultural or archaeological resource, a qualified archaeologist will clearly designate its boundaries with marker flags. The markers will not be distinguishable from other sensitive resources to be avoided.
TULE-CUL-2	The construction crew will be made aware of all areas to avoid, including cultural or archaeological site locations.
TULE-CUL-3	Construction activities will avoid any flagged cultural or archaeological resource sites.
TULE-CUL-4	Work will stop if cultural resources are discovered during ground-disturbing activities. If buried cultural resources, such as chipped or ground stone, historic debris, building foundations, or nonhuman bone are inadvertently discovered during ground-disturbing activities, work will stop in that area and within 100 feet of the find until a qualified archaeologist can assess the significance of the find and, if necessary, develop appropriate treatment measures. Treatment measures typically include development of avoidance strategies, capping with fill material, or mitigation of impacts through data recovery programs such as excavation or detailed documentation. The construction contractor and lead contractor compliance inspector will verify that work is halted until appropriate treatment measures are implemented.
TULE-CUL-5	<p>If human remains of Native American origin are discovered during ground-disturbing activities, it is necessary to comply with state laws relating to the disposition of Native American burials, which falls within the jurisdiction of the Native American Heritage Commission. If human remains are discovered or recognized in any location other than a dedicated cemetery, there will be no further excavation or disturbance of the site or any nearby area reasonably suspected to overlie adjacent human remains until: (1) the San Diego County coroner has been informed and has determined that no investigation of the cause of death is required; and (2) if the remains are of Native American origin,</p> <p>a) The descendants of the deceased Native Americans have made a recommendation to the land owner of the person responsible for the excavation work, for means of treating or disposing of, with appropriate dignity, the human remains and any associated grave goods as provided in Pub. Res. Code Sec. 5097.98, or</p> <p>b) The Native American Heritage Commission was unable to identify a descendant of the descendant failed to make a recommendation within 24 hours after being notified by the commission.</p>
TULE-PDF-1	<p>Iberdrola Renewables will comply with the applicable sections in NFPA 51-B "Fire prevention during welding, cutting and other hot work" and CFC Chapter 26 "Welding and other Hot Work." During Red Flag Alerts, operations involving cutting, welding, thermit welding, brazing, soldering, grinding, thermal spraying, use of torches, or other similar activity during construction or maintenance activities will be conducted according to NFPA 51-B. Red Flag Warnings are issued by the U.S. National Weather Service based on humidity of less than or equal to 25 percent, temperature greater than 75 F degrees and a sustained wind average of 15 miles per hour or greater. The project area is located in the National Weather Service San Diego Mountain (CA 258) zone. Iberdrola Renewables will implement a Hot Work Procedure on-site to minimize the potential for fire ignition. Components of the Hot Work Procedure will include:</p> <ul style="list-style-type: none"> • Prior to hot work activity commencing, the on-site Iberdrola Renewables fire safety coordinator will monitor daily the National Weather Service Red Flag Alert system. • In the event of a Red Flag Alert, prior to hot work activity commencing, the on-site Iberdrola Renewables fire safety coordinator will contact the local fire agency to determine the level of alert specific to the project area. • The on-site Iberdrola Renewables fire safety coordinator will require all hot work to be conducted according to NFPA 51-B. • Iberdrola Renewables will require all employees and/or sub-contractors who perform hot work during Red Flag Alerts to be trained under the applicable sections of NFPA 51-B. • The on-site Iberdrola Renewables fire safety coordinator will have the authority to modify hot work activities associated with construction and/or maintenance activities to the degree necessary to prevent fire ignition.

Table B-12 (Continued)

APM No.	Description
TULE-PDF-2	<p>Develop and implement a Construction and Maintenance Fire Prevention/Protection Plan. Iberdrola Renewables shall develop a multi-agency Construction and Maintenance Fire Prevention Plan. Plan reviewers shall include: CPUC, CAL FIRE, BLM, CSLC, and the County of San Diego. Iberdrola Renewables shall provide a draft copy of this Plan to each listed agency at least 90 days before the start of construction activities. Comments on the plan shall be provided by Iberdrola Renewables to all other participants, and Iberdrola Renewables shall resolve each comment in consultation with and to the satisfaction of CAL FIRE, SDRFPD and the SDCFA. The final plan shall be submitted to CAL FIRE, SDRFPD and SDCFA at least 30 days prior to the initiation of construction activities. Iberdrola Renewables shall fully implement the plan during all construction and maintenance activities. All construction work on the project shall follow the Construction Plan guidelines and commitments, and plan contents are to be incorporated into the standard construction contracting agreements for the construction of the project. Primary plan enforcement and implementation responsibility will remain with Iberdrola Renewables.</p> <p>At a minimum, plan contents will include the requirements of Title 14 of the California Code of Regulations, Article 8 #918 "Fire Protection" and the elements listed below:</p> <ol style="list-style-type: none"> 1. During the construction phase of the project, Iberdrola Renewables shall implement ongoing fire patrols. Iberdrola Renewables shall maintain fire patrols during construction hours and for 1 hour after end of daily construction, and hotwork. 2. Fire Suppression Resource Inventory – In addition to CCR Title 14, 918.1(a), (b), and (c), Iberdrola Renewables shall update in writing the 24-hour contact information and on-site fire suppression equipment, tools, and personnel list on quarterly basis and provide it to the CAL FIRE, SDRFPD, SDCFA, CPUC, BLM, and to state and federal fire agencies. 3. During Red Flag Warning events, as issued daily by the National Weather Service in SRAs and Local Responsibility Areas (LRA), all non-essential, non-emergency construction and maintenance activities shall cease. Utility and contractor personnel will be informed of changes to the Red Flag event status as stipulated by CAL FIRE. 4. All construction crews and inspectors shall be provided with radio and cellular telephone access that is operational along the entire length of the approved route to allow for immediate reporting of fires. Communication pathways and equipment shall be tested and confirmed operational each day prior to initiating construction activities at each construction site. The radio shall allow communications with other Iberdrola Renewables vehicles and construction trailer. All fires will be reported immediately upon detection. 5. Each member shall carry at all times a laminated card listing pertinent telephone numbers for reporting fires and defining immediate steps to take if a fire starts. Information on contact cards will be updated and redistributed to all crewmembers as needed and outdated cards destroyed, prior to the initiation of construction activities on the day the information change goes into effect. 6. Each member of the construction crew shall be trained and equipped to extinguish small fires in order to prevent them from growing into more serious threats. 7. Water storage tanks and access roads shall be installed and operational at time of start of construction.
TULE-PDF-3	<p>As part of the project design, a blasting plan will be prepared. The blasting plan will include identification of planned blasting locations, a description of the planned blasting methods, an inventory of receptors potentially affected by the planned blasting, and to determination the area affected by the planned blasting. Blasting methods will take into consideration the high wildland fire hazard conditions in and surrounding the project area. Precautions to prevent fire will be included in the blasting plan will include requirements to have all blasting charges capped with soil and/or other materials that are not combustible.</p> <p>Blasting activities are required to be observed by a Blasting Inspector. A Blasting Inspector is a person on the Sheriff's approved list of inspectors authorized to conduct inspections, before and after a blast. To be on the Sheriff's approved list, an inspector shall be certified by or registered with the International Conference of Building Officials, the International Code Counsel/Counsel of American Building Officials, the Building Officials & Code Administrator or the Southern Building Code Congress International.</p>

Table B-12 (Continued)

APM No.	Description
TULE-PDF-4	The project will comply with the County of San Diego Consolidated Fire Code, Section 96.1.3301.2, Explosives and Fireworks Applicability. The Fire Code requires a permit application to be issued prior to the start of blasting activities. Blasting activities shall be limited to Monday through Saturday between the hours of 7:00 a.m. and 6:00 p.m. or one-half hour before sunset, whichever occurs first, unless issuance of grant approval. Surrounding residents within 600 feet will be notified in writing within 600 feet of any major blast location or 300 feet from any minor blast location.
TULE-PDF-5	As a standard practice, Iberdrola Renewables does not allow construction waste to accumulate. Waste associated with project construction will be contained in metal containers and/or designated cleared construction staging areas (large items). The metal containers and staging areas will be monitored and emptied on a regular basis.
TULE-PDF-6	As part of the project construction and operations, chemicals such as oils and cleaners for turbines will be properly storage, used, and handled as regulated under the California Fire Code (CFC). Areas on the project site that store, use or handle these materials will be at least 50 feet from any building or turbine, and will have a fuel modification zone around them of at least 30 feet and will be constructed in compliance with the CFC. Dispensing of any motor vehicle fuels shall comply with the CFC. Spill control will be provided in all areas, and shall contain the contents of the largest container. Electrical systems shall comply with the CFC and with the National Electrical Code; NFPA 70, and with NFPA 497 where applicable. Grounding and bonding will be provided where necessary. Any transfer or dispensing pumps shall have a remote emergency shut down device 75 feet away. There shall be portable fire extinguishers with a minimum rating of 20 BC, located approximately 50 feet away and mounted on a visible post approximately 4 feet off ground. Safety signage shall be provided for any transfer/dispensing areas and “No Smoking” signs shall be posted.
TULE-PDF-7	<p>Based upon the <i>Estimate of Water Availability</i> memorandum (Geo-Logic Associates September 7, 2010 – Appendix B to the Applicant’s Environmental Document), on the conservative peak water use requirements of 250,000 gallons per day (associated with road construction, concrete mixing and dust control activities), an estimated continuous supply of water (24-hours per day, 7 days per week) will be required from wells pumping at a cumulative continuous rate of 124 gpm. Although there are several wells on the project site, two wells on the project site have been identified as readily available for project use:</p> <ol style="list-style-type: none"> 1. One well is located on Rough Acres Ranch approximately one to two miles north of I-8 between Ribbonwood Road and McCain Valley Road. Drilled in 2009, data provided on the well log for this well indicates that the estimated well yield is 60 gallons per minute (gpm); however, with the current pump in this well, the Ranch Manager indicates that the well produces at a rate of 50 gpm. A 72-hour constant rate aquifer pumping test was performed at this well at 50 gpm. Based on the current preliminary test data, there was very little response from pumping in the adjacent observation well, about 30 feet from the pumping well, and therefore it is reasonable to assume that sustained pumping at 50 gpm, at a minimum can be achieved from this well. Further, with a higher volume pump it may be possible to pump at greater volumes without significant impacts to other adjacent groundwater users; 2. One well is located on the Ewiiapaayp Reservation, about 7 miles north of Interstate 8 on La Posta Road. A 72-hour constant rate aquifer pumping test was conducted at this well at 80 gpm. Based on the preliminary test results it is reasonable to assume that sustained pumping at 80 gpm is feasible at this well location. <p>Therefore, based on the preliminary data from two recent pumping tests with a combined total pumping rate of 130 gpm, it is likely that the necessary water supply requirements for the project (124 gpm of continuous pumping, seven days a week) can be met from these two wells.</p> <p>There are four potential additional water supply sources available for the project. The State Correctional Facility is located about one half mile north of Interstate 8 off of McCain Road. This correctional facility maintains two wells with estimated production of 45 and 65 gpm. The Live Oak Springs Resort located south of Interstate 8 on Old Highway 80 about ¼-mile northwest of the intersection with Highway 94 may provide a</p>

Table B-12 (Continued)

APM No.	Description
	<p>source of water supply. This resort (and water company) operates a well that pumps about 40,000 gallons per day (25 to 30 gpm) and maintains a 100,000 gallon pond, and two large tanks with an additional 50,000 gallons of storage capacity. They have committed to providing 40,000 for immediate use and up to 80,000 gallons per day with additional storage tanks (pers. comm., September 8, 2010); equivalent to 28 to 55 gpm. The Jacumba Community Service District (CSD) also has indicated that their well produces 200 gpm and they will commit up to 40,000 gallons per day to the project (pers. comm., September 8, 2010); equivalent to about 28 gpm. Finally, the City of El Centro has indicated that they are willing to sell wastewater plant effluent to the project for use during the construction phase.</p> <p>The available on-site groundwater can provide the required project water requirements through continuous pumping at a rate of 124 gpm. Current pumping test results indicate at least 130 gpm can be achieved from the two tested wells, and potential greater volumes with a higher volume pump at the Rough Acres Ranch test well. However, with off-site water from the State Correctional Facility, Live Oak Springs Resort, and Jacumba CSD for purchase, an additional 80,000 to 120,000 gallons of water per day, or approximately 55 to 83 gpm of water could be available to support the project water supply needs; ample water for the nine-month construction period. With these additional off-site sources, the combined on-site and off-site water could be equivalent to an estimated 213 gpm could be made available in support of the project.</p> <p>If a fire were to occur in the project area, construction activities utilizing ground water would cease and the groundwater available from these sources could be used for firefighting purposes. In addition, based on informal conversations with the staff members of the various fire agencies and other sources would be utilized for firefighting purposes (HDR staff, Pers. Comm.).</p> <p>Iberdrola Renewables will provide four (4) additional water tanks to the SDRFPD to place at strategic locations throughout the site. The tanks will be installed and maintained by BR, with SDRFPD maintaining adequate water levels for fire protection services. The water tanks will provide a supplemental water source that can be utilized for additional fire suppression for the community of Boulevard and BLM lands that have limited access to water.</p> <p>The same wells will provide the source of water during operations. When the project turbines become operational, only a limited quantity of water will be required, estimated at 2,500 gallons per day to supply the operations and maintenance building services and support staff.</p>
TULE-PDF-8	<p>A Fire and Emergency Protection Services Agreement for the project shall be executed between Iberdrola Renewables and the SDRFPD, and other agencies as appropriate. The Agreement shall be executed by all parties prior to commencement of construction of the project. The purpose of the Agreement is to fund the employment and training of personnel, and acquisition and maintenance of equipment to provide fire and emergency protection services for the project. The Agreement will describe the scope of services to be provided by the SDRFPD, and other agencies as appropriate, and will be maintained throughout the life of the project.</p> <p>Iberdrola Renewables will educate the construction crew and maintenance employees as to potential dangers that may occur during construction and maintenance of the project. To reduce the possibility of fire ignition during hot work, Iberdrola Renewables will implement the Hot Work Procedure and coordinate with local fire authority regarding the specific conditions in the project area. The PDFs discussed in Section 3.6 will minimize the risk of ignition sources; therefore, the project's contribution to this impact is less than cumulatively considerable.</p>
TULE-PDF-9	<p>The 34.5 kV overhead collector lines as well as the 138 kV transmission lines will be designed in accordance with CPUC GO 95 "Rules For Overhead Electric Line Construction" and the current edition of the NESC to ensure sufficient clearance between conductors and vegetation to prevent contact. For example, the 138kV transmission line will have a minimum clearance from the conductor to the ground of 30 feet and the 34.5 kV overhead collector lines will have a minimum of 18.5 feet. Although, IBR's standard practice is to place the lines at a greater distance apart (e.g., 25 feet). Based on regular visual inspections, vegetation removal and management will be conducted below the lines to ensure this clearance is maintained.</p>
TULE-PDF-10	<p>The area within the project substation, which will contain transformers, capacitors, and other electrical components, will be cleared of vegetation, graveled, and maintained vegetation free. In addition, a 5-foot wide area outside the substation fence will be cleared and graveled. A 15-foot diameter area around transformers</p>

Table B-12 (Continued)

APM No.	Description
	<p>located at turbine towers will be cleared and graveled. Additional fuel management will occur for a balance of 100 feet from the turbine base.</p> <p>No switching devices with moving parts (fused cutouts, switches, reclosers) will be located on the poles. This removes a potential ignition source from arcing. Equipment within the substation, including transformers, will be protected in compliance with NFPA 850 and the CFC. Fire fighting foam concentrate will be required at the substation location in the event of an oil fire.</p>
TULE-PDF-11	The design of the power lines will comply with APLIC "Suggested Practices for Avian Protection on Power Lines" which is the industry standard developed to minimize avian contact with power lines. Bird caused flashovers are very unlikely for the project because the energized 138 kV conductors will have minimum distances of 30 vertical feet <u>to the ground</u> and 12 horizontal feet apart, and the 34.5 kV overhead collector lines will have a minimum distance of 18.5 feet vertical feet and 5 feet horizontal feet apart.
TULE-PDF-12	The lines and associated facilities will be designed in accordance with CPUC GO 95 "Rules for Overhead Electric Line Construction" and the current edition of the NESC to ensure the design minimizes the potential for inadvertent conductor contact.
TULE-PDF-13	Self-supporting steel poles will be utilized for the 138 kV transmission line. Steel and wood are being considered for 34.5 kV overhead collector system poles. If guy wires and anchors are used, they will be rated for a minimum of 150% of expected loading. This design approach eliminates the most likely cause of pole collapse, which is failure of a guy wire and/or anchor.
TULE-PDF-14	Periodic visual inspection of the 138 kV transmission line will occur and washing will occur on an "as needed" basis as determined by the visual inspections.
TULE-PDF-15	Electrical collection and transmission system and turbines will include the required FAA and CAL FIRE lighting and markings.
TULE-PDF-16	<p><i>Nacelle Fire Risk Reduction</i></p> <p>1. <i>Up-Tower</i> – Turbines with electrical (medium-voltage) equipment in the nacelle have a number of safety devices to detect electrical arc and smoke. For example, the turbine design being considered for the <u>project include the following fire detection components are included and that will be</u> mounted on key power cables within the nacelle:</p> <ul style="list-style-type: none"> • Smoke detectors; • Arc-flash sensors; and • <u>Over-current sensing transducers; and</u> • <u>Portable fire extinguishers.-</u> <p>Should any of these devices register an out-of-range condition, the device immediately commands a shutdown of the turbine and will disengage it from the electrical collection system <u>and send a notice through the SCADA system to the ECC in Portland, Oregon.</u> The entire turbine is electrically protected by current-limiting switchgear that is installed inside the base of the tower.</p> <p>The project will be operated and maintained by approximately 12 permanent full-time employees, who will monitor the wind turbines during normal business hours. In addition, Iberdrola Renewables' NCC in Portland, Oregon monitors and can control all of Iberdrola Renewables' wind turbines through the SCADA and is staffed 24 hours a day. Primary communications with the wind farm is via Telco T1 lines, and all plants have satellite backup capability. The NCC has the ability to control each turbine individually, as well as control the substation. Should any out-of-range issue occur at the project, the NCC will contact the sites' dedicated on-call person to deploy to the site to investigate and/or call emergency services if warranted by the type of out-of-range signal transmitted to the NCC.</p> <p><i>Down-Tower</i> – This type of turbine being considered for the project has the electrical components installed in metal cabinets inside the base of the tower, and a low-voltage-to-medium-voltage transformer installed adjacent to the transformer tower. In this configuration, the probability of an uncontained</p>

Table B-12 (Continued)

APM No.	Description
	<p>electrical fire in the nacelle is extremely remote, as there are no combustible materials inside the tower. However, <u>this turbine style still has the same risk of a fire associated with electrical components as the Up-Tower style does. the same risk of a fire associated with electrical components exists.</u> As with the other turbine type, a tower-based circuit breaker electrically protects the entire machine. <u>This location will also have supervised smoke detectors. The potential for fire ignition in the nacelle due to blade over speed, wind or vibration is limited due to the design of the turbine blades, which are equipped with a pitch system that allows the blades to be rotated in order to control and stop the turbine in high wind conditions. As back-up to the three independent blade pitch systems, the turbines are equipped with a mechanical breaking system. In addition, turbines are equipped with vibrations sensors that automatically shut the turbines down if vibrations exceed the normal operating conditions. The down-tower turbine type will include similar fire detection, fire suppression, and safety features in the nacelle as the up-tower turbine type (e.g., smoke detectors, arc flash mitigation relays and over-current protection), however, fire suppression on the down-tower transformer is unnecessary due to the enclosed conditions of the turbine and improved fire access to the site. For the down-tower turbine type, there is a very low potential of an electrical fire escaping the turbine and causing a wildland fire.</u></p> <p>In addition, a potential fire risk associated with wind turbines is improperly installed electrical equipment (e.g., technical defects or components in the power electronics, failure of power switches, failure of control electronics, high electrical resistance caused by insufficient contact surface with electrical connections, such as loose connections, insufficient electrical protection concept with respect to the identification of insulation defects and the selectivity of switch-off units, no pole mounted disconnected switches, inadequate surge protection, inadequate grounding due to incorrect design or improper installation).</p> <p>If fire ignition occurred within the Up-Tower or Down-Tower turbine type due to improperly installed electrical equipment, the fire protection and prevention features identified above would be triggered and the device that registered an out-of-range condition would immediately shutdown and an alarm would be indicated on the wind farm SCADA as well as on screens at Iberdrola Renewables' NCC in Portland, Oregon. In addition, signage will be posted at the NCC to call a 10 digit 24/7 landline phone number to emergency dispatch center in San Diego County in the case of an emergency.</p>
TULE-PDF-17	<p>Although a final decision on the type of wind turbine has not been made, the majority of turbine manufacturers have imbedded "grounding" systems within the turbine blades to prevent ignition of a fire due to lightning. All wind turbine models being considered for this project will incorporate blade lightning protection systems. In general, these systems consist of air-receptors on various locations along the length of the blade, ground-conducting straps in the hub, nacelle, and tower, lightning detection tell-tale circuit cards, and tower grounding to earth. As mentioned earlier, Iberdrola Renewables has nearly 50 million operating hours on its U.S. fleet, and over that time lightning-induced fire has not occurred.</p> <p>To provide separation of installed equipment from combustible vegetation, gravel will be placed in and around substation, O&M building, wind turbines, and transformers. The project proposes up to a 200-foot cleared area around each turbine depending on the site topography at the time of construction. Upon completion of construction, with the exception of an area 60 feet in diameter (gravel up to a 10-foot radius to provide surface stabilization), the 200-foot cleared area would be revegetated with fire safe (non-combustible), low fuel vegetation, in a spacing and height configuration consistent with fire agency standard practices for a distance necessary to provide a minimum of 100 feet of fuel management from the turbine base and/or transformer. The impact analysis in the environmental document assumes a permanent impact to a 200-foot radius around each turbine. Fuel management would be performed annually prior to May 1 and more often as needed.</p>
TULE-PDF-18	<ul style="list-style-type: none"> • No off-road vehicle use would be necessary because all wind turbine and associated project components (e.g., substation and O&M building) will be located in cleared areas. As part of the project design, existing access roads will be improved and new access roads are proposed <u>that meet the requirements of the County of San Diego Consolidated Fire Code (2009) where they occur on County lands with the exception of spurs that serve turbines only.</u>

Table B-12 (Continued)

APM No.	Description
	<ul style="list-style-type: none"> • Hot Work Procedure (PDF-1). • Construction, Operations, and Maintenance Fire Prevention/Protection Plan (PDF-2). • Road maintenance activities requiring the use of grading equipment will be suspended during red flag events. • Permanently assigned project vehicles will carry, as a minimum, a fire extinguisher, shovel, and two-way-radio.
TULE-PDF-19	No vehicle will be idle or parked in areas of combustible fuels, such as brush or grass. All wind turbine and associated project components (e.g., substation and O&M building) are located in cleared areas. As part of the project design, existing access roads will be improved and new access roads are proposed.
TULE-PDF-20	Portable equipment powered by two cycle engines or capable of producing significant exhaust heat will be located within the 200-foot radius surrounding the turbine in which vegetative fuel reduction will take place.
TULE-PDF-21	Work on energized equipment will be avoided whenever possible. Personnel performing work on energized equipment will be trained in applicable OSHA and other safety requirements.
TULE-PDF-22	Smoking is limited to cleared areas around the O&M building.
TULE-PDF-23	As part of the project design, existing access roads will be improved and new access roads are proposed that meet the requirements of the County of San Diego Consolidated Fire Code (2009) where they occur on County lands with the exception of spurs that serve turbines only. These improvements will have the effect of decreasing fire response times to the project area and general area, in the event of a fire or other emergency. The proposed access road improvements will also improve public safety should a vegetation fire occur in the area by providing alternate routes of egress. Currently the only public exit road from the McCain Valley area is McCain Valley Road. The proposed connector road between Ribbonwood and McCain Valley Road is proposed as a private road; however, it will not be gated. As a result, this road will be available to the community in the event of an emergency. This road will be improved to meet County of San Diego private road standards. Additionally, the turbine roads will improve access allowing fire crews and tanker trucks faster initial response in the project area. Fire and other emergency vehicles will also be able to utilize the access roads to improve response times to remote areas. BLM roads or turbine roads that are proposed to be gated shall be provided with an approved Knox Box as discussed in Section 5.1 [of the Tule Wind Applicant's Environmental Document].
TULE-PDF-24	<p>The O&M facility is the only new structure proposed that will include Iberdrola Renewables staff during business hours. The O&M building will include the PDF that provide fire prevention and protection.</p> <ul style="list-style-type: none"> • The facility construction, including walls, penetrations through walls, doors, vents, roof, glazing and any skylights, will comply with the County Building Code (CBC) Wildland Urban Interface construction standards in Section 92.1.704, and Chapter 7-A of the CBC, and the CFC. • The O&M building will be located on a 5-acre site including a parking lot and will be surrounded by a 4-acre cleared area. The substation facility will have the required 3-acre graveled fenced cleared area around it and will have adequate spacing from transformers and other potential fire sources. The project will provide a minimum of 100 feet of fuel management. • Any batteries would comply with the requirements in the CFC and would have secondary containment and required ventilation to prevent build up of hydrogen gas. • Various occupancies in the building, as classified by the CBC, will have the required fire separations and will comply with the CFC and CBC for the type of occupancy and activities therein; for example, storage, or maintenance shop. • Sprinklers with exception of control room, which may have an alternative suppression system. Fire Sprinkler system will be supervised by Iberdrola Renewables' Portland Control center and to the offsite 24/7 alarm monitoring company. Determination will be made by Iberdrola Renewables as to supervision by the alarm monitoring company. Supervision to a Fire District approved remote alarm monitoring company required based on number of sprinkler heads. Twenty heads requires electrical supervision of all valves in system, pumps, water tank level, etc. CFC Section 903.4.

Table B-12 (Continued)

APM No.	Description
	<ul style="list-style-type: none"> • The SCADA monitoring system will have emergency power source at the O&M building, in addition to 24/7 monitoring at the NCC. Both Iberdrola Renewable's on-site staff and staff at the NCC will have the emergency contact information for the fire agencies, and will coordinate to make sure that the fire agencies will be called in the event of a fire or medical emergency. • The control room will be separated from remainder of building by 1-hour fire rated walls for fire safety and will have exterior exits. • The building will have smoke detectors, which are supervised in control room, activate an alarm on exterior of building, and are supervised to the NCC. Alarms may not be transmitted to the offsite 24/7 alarm monitoring company, so as to avoid false calls to 911 resulting in an unnecessary response. • The building will have a KNOX key box on exterior by main door for use by firefighters. <p>Per the requirements of PRC 4291, <i>Reduction of Fire Hazards Around Buildings</i>, the project will provide 100 feet of fuel modification around all buildings, and is the primary mechanism for conducting fire prevention activities on property within CAL FIRE jurisdiction.</p> <p>In addition, Iberdrola Renewables will implement a brush management plan at its project O&M facility, turbine pads, and substation. This plan will be consistent with the following County Consolidated Fire Code:</p> <ul style="list-style-type: none"> • Under the County Consolidated Fire Code, brush is to be modified within 100 feet (31 meters) of structures in radius, called defensible space (Section 4707.2a). There are two zones to be aware of when creating a defensible space for fire mitigation. • Zone 1, From structure out to a minimum of 50 feet: "The area within 50 feet (15 meters) of a building or structure shall be cleared of vegetation that is not fire resistant and/or replanted with fire-resistant plants" (County Fire Code Section 4707.2a). • Zone 2, Between 50 to 100 feet from structures: "In the area between 50 to 100 feet (15 to 31 meters) from a building all dead and dying vegetation shall be removed. Native vegetation may remain in this area provided that the vegetation is modified so that combustible vegetation does not occupy more than 50 percent of the square footage of this area" (County Fire Code, Section 4707.2a).
TULE-PDF-25	<p>Transformers contain cooling oil, which can be ignited by an electrical arc. NFPA 850, including Section 10.5.2.6, provides recommendations for transformer protection. These recommendations will be followed. Transformers associated with the substation will be located approximately 50 feet from the O&M building and will <u>be surrounded by</u> a minimum of 100 feet of fuel management. The substation is proposed to be located adjacent to the O&M building on a 5-acre parcel and will be surrounded by a 3-acre graveled parcel providing a minimum of 100 feet of fuel management around the substation.</p> <p>Transformers will utilize fire walls for exposure protection and will have secondary containment to control any oil that could be released. The size of the containment must be adequate to contain the total amount of oil plus firefighting water for 15 minutes. NFPA 850 recommends 10 minutes however, per NFPA 11, foam delivery from hand lines assumes an application time frame of 15 minutes. Firefighting foam concentrate will be stored at substation for use by firefighters. Typically, a 3% Aqueous Film Forming Foam (AFFF) concentrate is used, and the application rate is 0.16 gpm/sq. ft. for 15 minutes from a firefighter hose line. In concept, the needed gpm flow rate for the hose lines is 250 gpm. This is subject to detailed design and size of the containment. Fire resistant oils can also be used if they do not contain polychlorinated biphenyls (PCBs) or other toxic materials. Prior to operations of the facility, actual design of the transformer fire protection measures will be determined by Iberdrola Renewables and submitted to SDRFPD and SDCFA for approval.</p>
TULE-PDF-26	<p>Prevention and minimization of fire risk is a primary concern for Iberdrola Renewables. Other typical best management practices related to combustible storage that will be implemented on the project site include:</p> <ul style="list-style-type: none"> • Minimizing accumulation of combustible material, only allow storage of flammable materials in fire rated cabinets, ensure all combustible waste material is collected and disposed of properly including the storage of oily rags in approved containers, maintain a list of potential fire hazards at the plant including how sources of ignition will be controlled for each of these potential hazards. • Perform periodic housekeeping inspections to find and mitigate any fire hazards found, ensure employees

Table B-12 (Continued)

APM No.	Description
	<p>and sub-contractors are trained in fire prevention, and ensure employees are trained in the use of fire extinguishers.</p> <ul style="list-style-type: none"> • Combustible storage and trash on site during construction and operation phases will be properly stored in a clear area with fuel modification around it, and be away from turbines and the substation. Such storage will be orderly and be removed from the site as soon as possible.
TULE-HAZ-1	Spill Prevention, Control and Countermeasure Plan. The Spill Prevention, Control, and Countermeasure plan shall identify where hazardous materials and waste will be stored on-site, what spill prevention measures will be implemented, the location of spill kits, the appropriate spill response action for each material or waste, and procedures for notification to the appropriate authorities.
TULE-HAZ-2	Hazardous Materials Management Plan. The Hazardous Materials Management Plan shall include storage, use, transportation, and disposal procedures of each hazardous material anticipated to be used at the site. The plan will establish; inspection procedures, storage requirements, storage quantity limits, inventory control, nonhazardous product substitutes, and disposition of excess materials. The hazardous materials management plan will also identify requirements for notices to federal and local emergency response authorities, and will include emergency response plans.
TULE-HAZ-3	Waste Management Plan. The waste management plan shall determine waste procedures, waste storage locations, waste-specific management and disposal requirements, inspection procedures, and waste minimization procedures.
TULE-HYD-1	The project applicant will consult the Department of California Fish and Game guidelines <u>and recommendations for culvert design so that culverts are appropriately sized and protected to prevent scour and sedimentation and ultimately to minimize the long-term maintenance impacts to the natural streambed.</u> The project design will meet a 10-year rain event to minimize the trapping of sediment
TULE-HYD-2	The project will follow the site design requirements outlined in the County of San Diego Storm Water Management Plan to limit the impacts to the project.
TULE-HYD-3	<p>Maintain pre-development rainfall runoff characteristics:</p> <ul style="list-style-type: none"> • Locate the project and road improvement alignments to avoid or minimize impacts to receiving waters or to increase the preservation of critical (or problematic) areas such as floodplains, steep slopes, wetlands, and areas with erosive or unstable soil conditions. • Minimize the project impervious footprint. • Conserve natural areas. • Where landscape is proposed drain rooftops, impervious sidewalks, walkways, trails and patios into adjacent landscaping. • Design and locate roadway structures and bridges to reduce the amount of work in live streams and minimize the construction impacts. • Implement the following methods to minimize erosion from slopes: <ul style="list-style-type: none"> ○ Disturb existing slopes only when necessary; ○ Minimize cut and fill areas to reduce slope lengths; ○ Incorporate retaining walls to reduce steepness of slopes or to shorten slopes; ○ Provide benches or terraces on high cut and fill slopes to reduce concentration of flows; ○ Round and shape slopes to reduce concentrated flow; ○ Collect concentrated flows in stabilized drains and channels.
TULE-HYD-4	<p>Protect slopes and channels:</p> <ul style="list-style-type: none"> • Minimize disturbances to natural drainages. • Convey runoff safely from the tops of slopes • Vegetate slopes with native or drought tolerant vegetation. • Stabilize permanent channel crossings.

Table B-12 (Continued)

APM No.	Description
	<ul style="list-style-type: none"> • Install energy dissipaters, such as riprap, at the outlets of new storm drains, culverts, conduits, or channels that enter unlined channels in accordance with applicable specifications to minimize erosion. Energy dissipaters shall be installed in such a way as to minimize impacts to receiving waters. • Other design principles which are comparable and equally effective. • Conserve natural areas, soils, and vegetation • Preserve well draining soils (Type A or B) • Preserve Significant Trees • Minimize disturbance to natural drainages • Set-back development envelope from drainages • Restrict heavy construction equipment access to planned green/open space areas • Minimize and disconnect impervious surfaces • Minimize soil compaction • Re-till soils compacted by construction vehicles/equipment • Collect and reuse upper soil layers of development site containing organic materials • Drain runoff from impervious surfaces to pervious areas • Curb-cuts to landscaping • Rural swales • Concave median • Cul-de-sac landscaping design • LID parking lot design • Permeable pavements • LID driveway, sidewalk, bike-path design • Permeable pavements • Pitch pavements toward landscaping • LID Building Design • Cisterns and rain barrels • Downspout to swale • Vegetated roofs • LID landscaping design • Soil amendments • Reuse of native soils • Smart irrigation systems • Street trees.
TULE-HYD-5	<p>The project will design outdoors material storage areas to reduce pollution introduction by ensuring:</p> <ul style="list-style-type: none"> • Hazardous materials with the potential to contaminate urban runoff shall either be: (1) placed in an enclosure such as, but not limited to, a cabinet, shed, or similar structure that prevents contact with runoff or spillage to the stormwater conveyance system; or (2) protected by secondary containment structures such as berms, dikes, etc. • The storage area shall be paved and sufficiently impervious to contain leaks and spills • The storage area shall have a roof or awning to minimize direct precipitation within the secondary containment area. <p>The project will design trash storage areas to reduce pollution introduction by:</p> <ul style="list-style-type: none"> • Paved with an impervious surface, designed not to allow run-on from adjoining areas, screened or walled to prevent off-site transport of trash.

Table B-12 (Continued)

APM No.	Description
	<ul style="list-style-type: none"> • Provide attached lids on all trash containers that exclude rain, or roof or awning to minimize direct precipitation. <p>The project will provide storm drain system stenciling and signage (if applicable):</p> <ul style="list-style-type: none"> • All storm drain inlets and catch basins within the Project area shall have a stencil or tile placed with prohibitive language (such as: “NO DUMPING – I LIVE IN <<name receiving water>>”) and/or graphical icons to discourage illegal dumping. • Signs and prohibitive language and/or graphical icons, which prohibit illegal dumping, must be posted at public access points along channels and creeks within the project area. • The project will use efficient irrigation systems and landscape design. • Employ rain shutoff devices to prevent irrigation after precipitation. • Design irrigation systems to each landscape area’s specific water requirements. • Use flow reducers or shutoff valves triggered by a pressure drop to control water loss in the event of broken sprinkler heads or lines. • Employ other comparable, equally effective, methods to reduce irrigation water runoff. <p>The project will comply with the County of San Diego SUSMP, Iberdrola Renewables will maintain the detention basins and swales/Brow/Ditches as a treatment control BMP during the operations and maintenance of the project.</p>
TULE-NOI-1	Turbines will be situated to minimize the amount of potential noise to surrounding residential structures.
TULE-NOI-2	A site-specific noise mitigation plan will be developed prior to construction.
TULE-NOI-3	A blasting plan will be prepared for each potentially impacted site. Depending upon the results of the blasting plan, mitigation measures may include coordination with building occupants so that blasting occurs in their absence, or at other acceptable times, to avoid nuisance or annoyance complaints. A rock anchoring or mini-pile system may be used to reduce the risk of damage to structures. Structures shall be restored if adversely affected by construction vibration, to an equivalent condition as that prior to the construction. Fair compensation for lost use will be provided to the owner. The project operator will notify nearby landowners of certain construction noise events in advance (e.g., if temporary blasting becomes necessary).
TULE-NOI-4	Decrease the amount of noise during construction to the greatest extent possible, including the use of appropriate mufflers and limiting the hours of construction. All stationary construction equipment will be located as far as practicable from nearby residences and other human activities.
TULE-NOI-5	Turbines will be kept in good running order throughout the operational life of the project.
TULE-NOI-6	The project operator will notify nearby landowners of certain construction noise events in advance (e.g., if temporary blasting becomes necessary).
TULE-NOI-7	Requiring original equipment manufacturer (OEM) or higher-performing mufflers on equipment.
TULE-NOI-8	Requiring the regular maintenance and inspection of construction machinery to allow for quieter operation.
TULE-NOI-9	Augmented backup alarms coupled with contractor observation to minimize alarm noise, which is a consistent area of concern and complaint on most construction projects.
TULE-NOI-10	Exhaust silencers used on machinery during construction to further reduce noise.
TULE-NOI-11	Augmented backup alarms coupled with contractor observation to minimize alarm noise.
TULE-NOI-12	Utilize noise barriers and machinery enclosures where feasible.
TULE-NOI-13	Ban the use of “Jake Braking” or engine compression braking on all trucks.
TULE-NOI-14	Specifying the proper usage and power for the particular construction procedure (no machinery overkill).
TULE-NOI-15	Implement a complaint resolution procedure to assure that any complaints regarding construction or operational noise are promptly and adequately investigated and resolved.
TULE-NOI-16	Construction equipment or stationary equipment not actively being used will not idle for more than 5 minutes.

East County Substation/Tule Wind/Energia Sierra Juarez Gen-Tie Projects
B. PROJECT DESCRIPTION

Table B-12 (Continued)

APM No.	Description
TULE-PHS-1	A safety assessment shall be conducted to describe potential safety issues and the means that would be taken to mitigate them, including issues such as site access, construction, safe work practices, security, heavy equipment transportation, traffic management, emergency procedures, and fire control.
TULE-PHS-2	A health and safety program shall be developed to protect both workers and the general public during construction, operation, and decommissioning of the project. Regarding occupational health and safety, the program shall identify all applicable federal and state occupational safety standards; establish safe work practices for each task (e.g., requirements for personal protective equipment and safety harnesses; Occupational Safety and Health Administration (OSHA) standard practices for safe use of explosives and blasting agents; and measures for reducing occupational electric and magnetic fields (EMF) exposures; establish fire safety evacuation procedures; and define safety performance standards (e.g., electrical system standards and lightning protection standards)). The program shall include a training program to identify hazard training requirements for workers for each task and establish procedures for providing required training to all workers. Documentation of training and a mechanism for reporting serious accidents to appropriate agencies shall be established.
TULE-PHS-3	The health and safety program shall establish a safety zone or setback for wind turbine generators from residences and occupied buildings, roads, rights-of-ways, and other public access areas that is sufficient to prevent accidents resulting from the operation of wind turbine generators. It shall identify requirements for temporary fencing around staging areas, storage yards, and excavations during construction or decommissioning activities. It shall also identify measures to be taken during the operation phase to limit public access to hazardous facilities (e.g., permanent fencing installed only around electrical substations, and turbine tower access doors locked).
TULE-PHS-4	The project shall be planned to minimize electromagnetic interference (EMI) (e.g., impacts to radar, microwave, television, and radio transmissions) and comply with Federal Communications Commission (FCC) regulations. Signal strength studies shall be conducted when proposed locations have the potential to impact transmissions. Potential interference with public safety communication systems (e.g., radio traffic related to emergency activities) shall be avoided.
TULE-PHS-5	The project shall be planned to comply with Federal Aviation Administration (FAA) regulations, including lighting regulations, and to avoid potential safety issues associated with proximity to airports, military bases or training areas, or landing strips.
TULE-PHS-6	Temporary fencing shall <u>may</u> be installed around staging areas and storage yards during construction to limit public access. Excavation areas will be provided with barriers surrounding them.
TULE-PHS-7	Permanent fencing shall be installed and maintained around electrical substations, and turbine tower access doors shall be locked to limit public access.
TULE-PHS-8	In the event the project results in electromagnetic interference (EMI), the operator shall work with the owner of the impacted communications system to resolve the problem. Additional warning information may also need to be conveyed to aircraft with onboard radar systems so that echoes from wind turbines can be quickly recognized.
TULE-REC-1	Provide improvements to the Lark Canyon and Cottonwood Campgrounds, as follows: <ul style="list-style-type: none"> • Shade cabanas at all of the camp sites • Roadways into the campgrounds upgraded to accommodate trailers • Trail signs and maps • Additional BBQ circles and grates.
TULE-REC-2	Provide signage for potential campground and OHV area closures.
TULE-TRAF-1	A transportation plan shall be developed, particularly for the transport of turbine components, main assembly cranes, and other large pieces of equipment. The plan shall consider specific object sizes, weights, origin, destination, and unique handling requirements and shall evaluate alternative transportation approaches.

Table B-12 (Continued)

APM No.	Description
TULE-TRAF-2	A traffic management plan shall be prepared for the site access roads to limit the potential for hazards from the increased truck traffic and ensure that traffic flow would not be adversely impacted. This plan shall incorporate measures such as informational signs, flaggers when equipment may result in blocked throughways, and traffic cones to identify any necessary changes in temporary lane configuration.
TULE-TRAF-3	<p>The following has been requested by <u>Caltrans</u> as part of the project design:</p> <ul style="list-style-type: none"> • All Caltrans standards for utility encroachments shall be met. • Clearances of overhead crossings shall conform to regulations of the California PUC, and the number of crossings to be minimized. • New installations under an existing paved roadbed shall be made by the boring and jacking method. Trenching under the traveled <u>paved roadway</u> will not be allowed. • For freeways and expressways, the placement of longitudinal encroachments is prohibited within controlled access rights-of-way. • Utilities shall not be located in median areas. • Transverse crossings should be normal (90 degrees) to the highway alignment where practical. If impractical, skews of up to 30 degrees <u>ferom</u> normal may be allowed. • Supports for overhead lines crossing freeways shall be located outside the controlled access right-of-way and not on cut or fill slopes and shall not impair sight distances. All installations shall be placed as close to the right-of-way line as possible. Above-ground utilities shall be outside of the clear recovery zone (20 feet from edge-or-travel way for conventional highways and 30 feet for freeways and expressways). Allowance should be made for future widening of the highways. • New installations shall not impair sight distances.

Source: Iberdrola Renewables, Inc. 2010.

B.5 ESJ Gen-Tie Project

This section details the ESJ Gen-Tie Project components and design specifications, describes the construction activities and procedures associated with the ESJ Gen-Tie Project, explains the O&M procedures, and presents a comprehensive listing of Energia Sierra Juarez U.S. Transmission, LLC’s APMs to reduce potential impacts resulting from the ESJ Gen-Tie Project.

B.5.1 ESJ Gen-Tie Project Components

Once constructed, the proposed ESJ Gen-Tie Project would have the capacity to import up to 1,250 MW of renewable energy generated in Northern Baja California, Mexico, to the existing SWPL Transmission Line in eastern San Diego County, California. The project would construct, operate, and maintain a less than 1-mile segment of an electrical generator tie-line (gen-tie) crossing the U.S.–Mexico border and terminating at the proposed ECO Substation. Only renewable energy would be transmitted via the gen-tie. Although Energia Sierra Juarez U.S. Transmission LLC has proposed a 500 kV and a 230 kV Gen-Tie, only one of these would be built, with the 230 kV option being the preferred alternative. In addition, in order to access well water for use during construction, a new, approximately 150-foot by 20-foot access route is

proposed from Old Highway 80 north to the existing well site. The new access road would facilitate access to an existing water well on property owned by the Jacumba Community Services District (AECOM 2011a, 2011b).

Table B-13, Summary of ESJ Gen-Tie Project Components, provides an overview, general location, and summary of the permanent and temporary impacts of each project component. Figures B-1, Regional Map, B-2, Vicinity/Overview Map, and B-32, ESJ Gen-Tie Site Plan, depict the location of the project components.

B.5.1.1 500 kV or 230 kV Gen-Tie and Support Structures

Location

As shown on Figures B-2B, Vicinity/Overview Map, and B-32, ESJ Gen-Tie Site Plan, the 500 kV or 230 kV gen-tie and associated support structures would be constructed from the U.S.–Mexico border northwest to the proposed ECO Substation located in southeastern San Diego County, approximately 4 miles east of the unincorporated community of Jacumba. Figure B-33, ESJ Gen-Tie Project and Off-Site Well Location, shows the location of the ESJ Gen-Tie site and the existing well and access road site. The access road would be located off Old Highway 80, approximately 4 miles east of the ESJ Gen-Tie Project site, in the unincorporated community of Jacumba (AECOM 2011a, 2011b).

The 500 kV gen-tie would require approximately 10.65 acres of privately owned land for the placement of four steel lattice transmission structures (the fifth structure would be located within the proposed ECO Substation), permanent access to the gen-tie structures, and permanent ROW. The 230 kV gen-tie would require 9.6 acres of privately owned land for the placement of four steel lattice transmission structures (the fifth structure would be located within the proposed ECO Substation), permanent access to the gen-tie structures, and permanent ROW.

East County Substation/Tule Wind/Energia Sierra Juarez Gen-Tie Projects
B. PROJECT DESCRIPTION

Table B-13
Summary of ESJ Gen-Tie Project Components

Project Component	Location	Description	Project Impacts	
			Temporary Impacts (acres) ¹	Permanent Impacts (acres)
500 kV Gen-tie and Support Structures	Generally in southeastern San Diego County, approximately 4 miles east of the unincorporated community of Jacumba. The gen-tie would travel north from the U.S.-Mexico border, crossing private, undeveloped County of San Diego jurisdictional land and terminate within the 500 kV yard of the SDG&E proposed ECO Substation.	Construction, operation, and maintenance of an approximate one mile segment of a single-circuit electrical gen-tie crossing the U.S.-Mexico border and terminating at the proposed ECO Substation. The gen-tie line would only transmit renewable energy and would be supported by approximately five steel lattice towers or steel monopoles. The northernmost support structure would be located within the proposed ECO Substation.	0	3.45
Gen-Tie Tower Access Road	Generally along the 500 kV gen-tie (see above).	The new road would facilitate access from the legal property access road (off of Old Highway 80) to the gen-tie support structures.	0	0.8
28-Foot Property Legal Access Road and Turnaround	Off of Old Highway 80, approximately 4 miles east of the unincorporated community of Jacumba and 0.5 mile south of I-8.	The existing legal property access road would be widened to 28 feet and a new turnaround (required by the Rural Fire Protection District) would be constructed.	0	4.5
<u>150-Foot by 20-Foot Access Road to Existing Water Well</u>	<u>Off of Old Highway 80, approximately 4 miles east of the ESJ Gen-Tie Project site, in the unincorporated community of Jacumba.</u>	<u>The new road would facilitate access to an existing water well on property owned by the Jacumba Community Services District from Old Highway 80.</u>	<u>0.063</u>	<u>0</u>
<i>or</i>				
230 kV Gen-Tie and Support Structures	Generally in southeastern San Diego County, approximately 4 miles east of the unincorporated community of Jacumba. The gen-tie would travel north from the U.S.-Mexico border, crossing private, undeveloped County of San Diego jurisdictional land and terminate within the 230/138 kV yard of the SDG&E proposed ECO Substation.	Construction, operation, and maintenance of an approximate one mile segment of a double-circuit electrical generator tie-line gen-tie crossing the U.S.-Mexico border and terminating at the proposed ECO Substation. The gen-tie line would only transmit renewable energy and would be supported by approximately five steel lattice towers or steel monopoles. The northernmost support structure would be located within the proposed ECO Substation.	0	2.2
Gen-Tie Tower Access Road	Generally along the 230 kV gen-tie (see above).	The new road would facilitate access from the legal property access road (off of Old Highway 80) to the gen-tie support structures.	0	0.9

East County Substation/Tule Wind/Energia Sierra Juarez Gen-Tie Projects
B. PROJECT DESCRIPTION

Table B-13 (Continued)

Project Component	Location	Description	Project Impacts	
			Temporary Impacts (acres) ¹	Permanent Impacts (acres)
28-Foot Property Legal Access Road and Turnaround	Off of Old Highway 80, approximately 4 miles east of the unincorporated community of Jacumba and 0.5 mile south of I-8.	The legal property access road would be widened to 28 feet and a new turnaround (required by the Rural Fire Protection District) would be constructed.	0	4.5
150-Foot by 20-Foot Access Road to Existing Water Well	Off of Old Highway 80, approximately 4 miles east of the ESJ Gen-Tie Project site, in the unincorporated community of Jacumba.	The new road would facilitate access to an existing water well on property owned by the Jacumba Community Services District from Old Highway 80.	<u>0.063</u>	<u>0</u>

¹ See Section B.5.2.2 for further details regarding temporary workspace requirements.

Description

The ESJ Gen-Tie Project consists of the construction, operation, and maintenance of a single-circuit 500 kV line or a double-circuit 230 kV line supported on either five 150-foot steel lattice towers or five 170-foot steel monopoles. The 500 kV line would interconnect with the 500 kV yard of the ECO Substation and the 230 kV line would interconnect with the 230/138 kV yard of the ECO Substation. The northernmost support structure of both lines would be located within the fenced portion of the proposed ECO Substation. The total length of the gen-tie to the first point of interconnection in Mexico would be approximately 3 miles; 2 miles of the gen-tie would be constructed, owned, operated, and maintained by a Mexican subsidiary of Sempra Energy Mexico, Energia Sierra Juarez S. de R.L. de C.V. and would be subject to the permitting requirements of the Mexican government. The remaining 1 mile of gen-tie line would be constructed by ESJ U.S. Transmission, LLC on private land in the U.S. and is addressed in this EIR/EIS. An additional overhead static ground wire running above the conductors would have a fiber-optic core for communications between the ESJ Jacume Substation in Mexico and the proposed ECO Substation.

The detailed parameters of the 500 kV and 230 kV interconnections are provided in Table B-14, Design Parameters of ESJ Gen-Tie 500 kV and 230 kV Interconnections.

Table B-14
Design Parameters of ESJ Gen-Tie 500 kV and 230 kV Interconnections

Parameter	500 kV Interconnection	230 kV Interconnection
Maximum Capacity	1250 MW	1250 MW
Number of Circuits	Single Circuit	Double Circuit
Minimum Ground Clearance	39 ft	34 ft
Permanent ROW	214 ft	130 ft
Number of Structures	3 to 5	3 to 5
Maximum Spacing Between Structures	1500 ft	1500 ft
Maximum Height of Lattice Towers	150 ft	150 ft
Maximum Base of Lattice Towers	34 ft x 34 ft	29 ft x 29 ft
Foundation of Lattice Tower at each corner	3–6 ft diameter	3–6 ft diameter
Maximum Height of Steel Monopoles	170 ft	150 ft
Foundation of Steel Monopoles	7–9 ft diameter	6–9 ft diameter

Source: ESJ 2009.

As shown in the Table B-14, the 500 kV interconnection would be constructed within a 214-foot-wide permanent ROW while the 230 kV interconnection would be constructed within a 130-foot permanent ROW. A combination wire stringing site/construction laydown and parking area would be located near the northern terminus of either route. The combination laydown and

parking area for the 500 kV interconnection would be approximate 1.9 acres and 2.0 acres for the 230 kV interconnection, respectively.

Thirty feet of defensible space would be provided around all sides of each lattice tower or monopole. In addition, ESJ U.S. Transmission, LLC would provide 10 feet of clearance between all vegetation and wire and all gen-tie structures would be marked. Proposed lattice towers or monopoles would be spaced a maximum of 1,500 feet apart. Specific tower/monopole locations may be adjusted based on final design and, if necessary, to avoid sensitive cultural resources. No poles would be located within 150 feet of the international border. The type of gen-tie proposed by the project rarely causes interference to radio and television signals and there are no adjacent or nearby land uses where inference might be an issue. Fencing around towers and lighting on towers/monopoles is not proposed.

B.5.1.2 Access Roads

Location

As shown in Figure B-32, ESJ Gen-Tie Site Plan, a gen-tie tower access road would generally be located adjacent to the 500 kV or 230 kV gen-tie route and would provide access to the gen-tie support structures via the legal property access road and Old Highway 80. The property access road is located off Old Highway 80, approximately 4 miles east of the unincorporated community of Jacumba, 0.5 mile south of I-8, and approximately 200 feet south of the proposed ECO Substation.

From Old Highway 80, the ESJ Gen-Tie Project would have two property access road options, Option A and Option B. Option A is the historical property easement; however, the County of San Diego determined this easement did not satisfy the County's Site-Sight Distance requirements. Option B satisfies the County's Site-Sight Distance requirements. The locations and alignments for both options are shown on Figure B-32, ESJ Gen-Tie Site Plan. Access roads associated with the 500 kV gen-tie would require 5.3 acres of land and would include improvements to the approximate 0.9-mile legal property access road and a less than 1-mile gen-tie tower access road. Access roads associated with the 230 kV gen-tie would require 5.4 acres of land and would include improvements to the approximate 0.9-mile legal property access road and an approximate 0.6-mile gen-tie tower access road.

Description

As required by the Rural Fire Protection District, the existing access road would be widened to 28 feet and a new turnaround area within a 40-foot-wide easement would be constructed (portions of the property access road already exist and would be improved while other portions do not exist and would be newly constructed). The entire area within the 40-foot-wide easement

could be impacted during construction activities. The new turnaround area is depicted on Figure B-32, ESJ Gen-Tie Site Plan.

As shown on Figure B-32, a permanent gen-tie tower unpaved access road would be constructed and would parallel the selected gen-tie route. The gen-tie tower access road and foundations for the lattice towers or monopoles would be located entirely within the permanent ROW proposed for either the 500 kV or 230 kV interconnection. The gen-tie tower access road would be approximately 12 feet wide and would consist of graded dirt.

B.5.2 ESJ Gen-Tie Project Construction

This section presents an overview of construction methods typically used for construction of overhead gen-tie lines and new pole structures.

B.5.2.1 Construction Schedule

Construction of the proposed ESJ Gen-Tie Project is anticipated to require 6 months to complete. While the schedule would be modified to begin after County of San Diego approval and after CPUC approval (for the proposed ECO Substation), 6 months is anticipated to be adequate to construct the ESJ Gen-Tie Project.

B.5.2.2 Construction Activities and Methods

Site Preparation

A consolidated construction laydown/parking/stringing area (approximately 1.9 acres for the 500 kV gen-tie and 2.0 acres for the 230 kV gen-tie) would be cleared and graded (Figure B-32, ESJ Gen-Tie Site Plan, for location of laydown/parking/stringing area). All other work areas, including the defensible space established around each tower/pole, would be located within the permanent ROW and are therefore considered permanent impacts. Vegetation along the proposed access roads would be cleared and grubbed. Consistent with applicable regulations, debris generated by vegetation removal would be removed off site and disposed of properly. Minor grading would be required for the tower/pole pads. Topsoil removed during grading activities would be stockpiled in the construction laydown/parking/stringing area. The topsoil would be utilized during final grading of the gen-tie access road and tower/pole pad areas. Based on preliminary engineering design, grading would require the export of soil (ESJ 2009). Total earthwork associated with project construction would be approximately 20,000 CY (Burns and McDonnell 2009).

Foundation Construction

Gen-tie towers/poles would be supported on excavated, reinforced concrete foundations. A backhoe or similar excavation equipment would be used to excavate foundations. The area of disturbance at each tower/pole location would be an area of approximately 150 feet by 200 feet.

Aboveground Equipment Installation

Stringing of the gen-tie line would be done in a similar manner as described for the ECO Substation Project 138 kV transmission line component.

Post-Construction Restoration

The project will comply with the San Diego County Construction and Demolition materials Ordinance, which places recycling standards on construction and demolition debris. Waste (i.e., trash, recyclable materials, and debris) generated during construction of the ESJ Gen-Tie Project would be placed into dumpsters and/or covered bins, which would be hauled from the dumpster/bin site by a licensed waste hauler. In addition, construction workers would remove trash and debris at the end of each workday. Portable toilets would be brought to the project site for use by construction workers. Portable facilities would be installed and removed from the site by a licensed portable sanitation company and wastes would be disposed of at an approved facility. A final site cleanup and inspection would be conducted upon completion of construction.

B.5.2.3 Construction Personnel and Equipment

Construction of the ESJ Gen-Tie Project would require approximately 20 to 25 workers per day for up to 6 months. Approximately 5 to 15 construction vehicles would be operating on site during construction, with approximately 10 to 20 worker vehicles entering or leaving the site each day. Access to the project area would be provided by I-8, Old Highway 80, and the property legal access road off Old Highway 80.

Table B-15, Construction Equipment Associated with the ESJ Gen-Tie Project, provides an estimate of the construction vehicles and equipment and usage for the various construction activities associated with the project.

Table B-15
Construction Equipment Associated with the ESJ Gen-Tie Project

Activity	Equipment Type and Quantity	
	Type	Qty
Survey Sites	pickup truck	1
Worker Commuting	pickup truck	20
Marshalling Yards	pickup truck	3
	water truck	1
	tractor truck w/trailer	1
	hydraulic crane, 25 ton	1
	loader, model 980	1
	forklift, 5 ton	1
	portable generator	1
Grading and Road Work	pickup truck	2
	water truck	1
	dozer	1
	roller	1
Foundations	pickup truck	2
	water truck	1
	concrete truck	2
	drill rig	1
Steel Assembly and Erection	pickup truck	3
	water truck	1
	tractor truck w/trailer	1
	crane, 40 ton	1
	air compressor	1
	portable generator	1
Conductor Installation	pickup truck	2
	water truck	1
	flatbed trucks w/reels	1
	rigging truck	5
	dump truck	1
	puller tensioner	1
	splice rig	1
	portable generator	1
Cleanup	pickup truck	2

Note: Construction activities occur 6 days per week maximum and daily operating hours and daily vehicle miles travelled (VMT) are maximum estimates.

Source: ESJ 2009.

B.5.2.4 Water Usage

Assuming the use of two 2,500-gallon water trucks a day over a 6-day work week, construction of the ESJ Gen-Tie Project would require approximately 780,000 gallons of water for the watering of roads and minimizing dust generated from traffic and excavation activities and for aid in soil compaction. . Water would be transported to the site in tank trucks and temporary on-site storage of water may be possible. During operations, very little water would be needed and usage would mainly consist of the occasional use of a pressure washer on insulators to remove dirt and minimize arcing. The source of water is non-potable water from the Jacumba Community Services District. ~~A Major Use Permit for Groundwater Extraction Operation will need to be obtained from the County before purchasing water from the Jacumba Community Services District (Bennett 2010).~~ ESJ U.S. Transmission, LLC, on behalf of Jacumba Community Service District, is preparing a San Diego County Major Use Water Extraction Permit (MUP) Application to allow for the acquisition of water from an existing Jacumba Community Service District warm water well and its use at the ESJ U.S. project site to control fugitive dust during an approximately 6-month construction schedule (AECOM 2011a, 2011b).

Alternatively, if water cannot be obtained from the Jacumba Community Services District, a well may be drilled on site. The last option would be to truck water in from a nearby location, such as the town of Alpine.

B.5.3 ESJ Gen-Tie Project Operations and Maintenance

During operation of the gen-tie, one to two existing Sempra workers would be required to patrol and visually inspect the selected gen-tie on a periodic basis. O&M-related traffic would consist of approximately two vehicles entering and leaving the site weekly. Additionally, maintenance activities for gen-tie tower access roads would occur (on average) two times per year and on an as-needed basis and would include grading and minor repairs. Areas within the 40-foot-wide easement but beyond the 28-foot-wide gen-tie access road would be revegetated with a native seed mix upon completion of construction.

Thirty feet of defensible space would be maintained around all sides of each lattice tower or monopole. In addition, ESJ U.S. Transmission, LLC would provide 10 feet of clearance between all vegetation and wires. Each lattice tower or monopole would be marked.

B.5.4 ESJ Gen-Tie Project Applicant Proposed Measures

Table B-16, ESJ Gen-Tie Project Applicant Proposed Measures, lists APMs as proposed by Energia Sierra Juarez U.S. Transmission, LLC.

Table B-16
ESJ Gen-Tie Project Applicant Proposed Measures

APM No.	Description
ESJ APM-AES-01	Construction activities would be kept clean and inconspicuous as possible. Where practical, construction storage and staging would be screened with opaque fencing from close-range residential views.
ESJ APM-AIR-01	All active construction areas, unpaved access roads, parking areas, and staging areas would be watered or stabilized with non-toxic soil stabilizers as needed to control fugitive dust.
ESJ APM-AIR-02	Exposed stockpiles (e.g., dirt, sand) would be covered and/or watered or stabilized with non-toxic soil binders as needed to control emissions.
ESJ APM-AIR-03	Trucks transporting bulk materials would be completely covered unless two feet of freeboard space from the top of the container is maintained with no spillage and loss of materials. In addition, the cargo compartment of all haul trucks would be cleaned and/or washed at the delivery site after removal of the bulk material.
ESJ APM-AIR-04	Movement of bulk material handling or transfer would be stabilized prior to handling or at a point of transfer with application of sufficient water, chemical stabilizers, or by sheltering or enclosing the operation and transfer line.
ESJ APM-AIR-05	Traffic speeds on unpaved roads and the ROW would be limited to not more than 15 miles per hour (mph).
ESJ APM-AIR-06	Vehicle idling time would be limited to a maximum of five minutes for vehicles and construction equipment, except where idling is required for the equipment to perform its task.
ESJ APM-AIR-07	If suitable park and ride facilities are available in the Project vicinity, construction workers would be encouraged to carpool to the job site to the extent feasible. The ability to develop an effective carpool program for the Project would depend upon the proximity of carpool facilities to the job site, the geographical commute departure points of construction workers, and the extent to which carpooling would not adversely affect worker show-up time and the Project's construction schedule.
ESJ APM-BIO-01	Littering would not be allowed. Food-related garbage and trash would be removed from the Project area daily.
ESJ APM-BIO-02	Smoking would only be allowed in cleared areas or in enclosed vehicles to reduce the potential for wildfires.
ESJ APM-BIO-03	All earth-moving equipment would be confirmed to be clean and free of mud and vegetative material before first arriving at the construction site. If the equipment leaves the Project site, it must be confirmed to be clean and free of mud and vegetative material prior to re-entering the site.
ESJ APM-BIO-04	Firearms would be prohibited in all Project areas.
ESJ APM-BIO-05	Project personnel would not be allowed to bring pets to any Project area to minimize harassment or killing of wildlife and to prevent the introduction of destructive animal diseases to native wildlife populations.
ESJ APM-BIO-06	No harm, harassment, or collection of plant and wildlife species would be allowed. Feeding of wildlife would be prohibited.
ESJ APM-BIO-07	Prior to construction, all ESJ, contractor, and subcontractor personnel would receive training regarding the appropriate work practices necessary to effectively implement the APMs and to comply with the applicable environmental laws and regulations, including appropriate wildlife avoidance; impact minimization procedures; the importance of these resources, and the purpose and necessity of protecting them; and methods for protecting sensitive ecological resources. The training would include best management practices (BMPs) to reduce the potential for erosion and sedimentation during construction of the Project.
ESJ APM-BIO-08	Except when not feasible due to physical or safety constraints, all Project vehicle movement would be restricted to existing access roads and access roads constructed as a part of the Project.

Table B-16 (Continued)

APM No.	Description
ESJ APM -BIO-09	Prior to the start of construction, the boundaries of plant population designated as sensitive by the USFWS or CDFR, and other resources designated sensitive by ESJ and the resource agencies, would be delineated with clearly visible flagging or fencing. The flagging and/or fencing would be maintained in place for the duration of construction. Flagged and fenced areas would be avoided to the extent practicable during construction activities in the area.
ESJ APM -BIO-10	Prior to construction, ESJ would remove all existing raptor nests from existing structures that would be affected by Project construction. Removal of nests would occur outside of the raptor breeding season (January to July). If it is necessary to remove an existing raptor nest during the breeding season, a qualified biologist would survey the nest prior to removal to determine if it is active. If the nest is inactive, it would be dismantled and removed from the site promptly under the supervision of a biological monitor. If the nest is determined to be active, it would not be removed and the biological monitor would monitor the nest to ensure nesting activities and/or breeding activities are not disrupted. If the biological monitor determined that Project activities are disturbing or disrupting nesting activities, the monitor would make recommendations to reduce the noise and/or disturbance in the vicinity of the nest.
ESJ APM -BIO-11	Construction night lighting in sensitive habitats would be minimized to the extent feasible. Exterior lighting within the Project area and adjacent to undisturbed habitat would be the lowest illumination allowed for human safety, selectively placed, shielded, and directed away from preserved habitat to the maximum extent practicable.
ESJ APM -BIO-12	Nighttime vehicle traffic volume associated with Project activities would be kept to a minimum and speeds would be limited to 10 miles per hour to prevent mortality of nocturnal wildlife species.
ESJ APM -BIO-13	Structures would be constructed to conform to the Avian Power Line Interaction Committee's <i>Suggested Practices for Avian Protection on Power Lines</i> to help minimize impacts to raptors.
ESJ APM -BIO-14	At the completion of the Project, all construction materials would be removed from the site.
ESJ APM -BIO-15	Temporarily disturbed areas on the property access road would be reseeded with an appropriate seed mix that does not contain invasive, non-native plant species in accordance with landowner.
ESJ APM -CUL-01	Prior to construction, all ESJ, contractor, and subcontractor Project personnel would receive training regarding the appropriate work practices necessary to effectively implement the APMs and to comply with the applicable environmental laws and regulations, including the potential for exposing subsurface cultural resources and paleontological resources and to recognize possible buried resources. This training would include presentation of the procedures to be followed upon discovery or suspected discovery of archaeological materials, including Native American remains, and their treatment, as well as of paleontological resources.
ESJ APM -CUL-02	Known cultural resources that can be avoided would be demarcated as Environmental Sensitive Areas. Construction crews would be instructed to avoid disturbance of these areas.
ESJ APM -CUL-03	In the event that cultural resources are discovered, an on-call archaeologist would have the authority to divert or temporarily halt ground disturbance to allow evaluation of potentially significant cultural resources. The archaeologist, in consultation with ESJ would determine the significance of the discovered resources. ESJ Environmental Project Manager must concur with the evaluation procedures to be performed before construction activities are allowed to resume. For significant cultural resources, a Research Design and Data Recovery Program would be prepared and carried out to mitigate impacts.
ESJ APM -CUL-04	All collected cultural remains would be cleaned, cataloged, and permanently curated with an appropriate institution. All artifacts would be analyzed to identify function and chronology as they relate to the history of the area. Faunal materials would be identified as to species.
ESJ APM -HAZ-01	Prior to construction, all ESJ, contractor, and subcontractor Project personnel would receive training regarding the appropriate work practices necessary to effectively comply with the applicable environmental laws and regulations associated with hazardous materials.
ESJ APM -HAZ-02	ESJ would implement the Fire Protection Plan developed in conjunction with Rural Fire during all construction, operation, and maintenance work associated with the Project.

Table B-16 (Continued)

APM No.	Description
ESJ APM -NOI-1	Construction activities will occur during the times established by the local ordinances (generally between 7 a.m. and 7 p.m. Monday through Saturday), with the exception of certain activities where nighttime and weekend construction activities are necessary, including, but not limited to, delivery of substation transformers, filling of substation transformer, system transfers, pouring of foundations, and pulling of the conductor, which require continuous operation or must be conducted during off-peak hours per agency requirements. For any work that cannot occur during those timeframes, ESJ would limit construction activities so that noise would not exceed an hourly average of 55 decibel (dB) when measured at the border of the nearest parcel with an inhabited residence. If activities cannot be limited to meet this noise threshold, ESJ would communicate the exception to the County of San Diego in advance of conducting the work that would exceed the threshold.
ESJ APM-FIRE-1 ¹	A project will have a fire access road and turnaround. The fire access road will be a 28-foot graded width that shall be improved to 24 feet in width with decomposed granite where it connects from Old Highway 80 to the gen-tie line to the proposed ECO Substation. A turnaround will be required within 150 feet of the termination of the road at the proposed substation. A 20-foot-wide dirt access road will be provided along the ROW for maintenance of the gen-tie and for patrolling of the property.
ESJ APM-FIRE-2	The project will have 30 feet of fuel modification on all sides of the towers, 10 feet clearance between vegetation and wires, and marking of towers. Prescribed defensible space will be maintained on at least an annual basis, prior to May 1, or more often as needed.
ESJ APM-FIRE-3	The project applicant will work closely with the Rural Fire Protection District Fire Chief in preparing a Funding Agreement for firefighting resources.

B.6 References

Adam, J. 2010. “Water Availability 2010 for the San Diego Gas & Electric East County Substation Project, SWA Gen. File: Water Availability.” Letter from Jack Adam, Director of Engineering, Sweetwater Authority. August 25, 2010.

AECOM. 2011a. *Draft Archaeological and Historical Investigations for the Energia Sierra Juarez U.S. Major Use Water Extraction Permit (MUP) Application Jacumba, California*. MUP 10-014, KIVA Project 3300-10-014. Prepared for the County of San Diego Department of Planning and Land Use by AECOM. San Diego, California: AECOM. February 2011.

AECOM. 2011b. “Energia Sierra Juarez (ESJ) Well Access Road – Project Number 09-0107420.” Letter report from P. Jacks and V. Novik (AECOM) to P. Brown (County of San Diego Department of Planning and Land Use). February 3, 2011.

¹ APMs for fire are as proposed in the project’s Fire Protection Plan (Hunt Research Corporation 2009).

Bennett, J. 2010. "Groundwater Supply Options." Memorandum to Patrick Brown, project planner, from Jim Bennett, groundwater geologist, County of San Diego Department of Planning and Land Use. Project Number P09-008. March 4, 2010.

BLM (Bureau of Land Management). 2008. Instruction Memorandum 2009-043. December 18, 2008.

Burns and McDonnell. 2009. *Hydrology Study ESJ Gen-Tie Line 230kV & 500kV Alternatives, San Diego County, California*. Burns & McDonnell Engineering Company, Inc. June 2009.

ESJ (ESJ U.S. Transmission, LLC). 2009. San Diego County Major Use Permit Application Amended Project Description. June 2009.

Geo-Logic Associates. 2010. *Groundwater Investigation Report, Tule Wind Farm, East San Diego County*. December 2010.

Hunt Research Corporation. 2009. "Short Form Fire Protection Plan (Letter Report, Revised): Energia Sierra Juarez U.S. Transmission Gen-Tie Project (ESJ Gen-Tie.); Jacumba." Letter report from J.W. Hunt (Hunt Research Corporation) to D. Nissen (Rural Fire Protection District) and P. Dawson (County of San Diego, Department of Planning and Land Use). September 10, 2009.

Iberdrola Renewables, Inc. 2010. *Applicant's Environmental Document: Tule Wind San Diego County, California*. San Diego, CA: Prepared by HDR Engineering, Inc. September 2010.

Iberdrola Renewables, Inc. 2011a. "Comments of Iberdrola Renewables, Inc. regarding the Tule Wind Project Draft DEIR/DEIS-Modified Project Layout" and "Comments of Iberdrola Renewables, Inc. on the Joint Draft Environmental Impact Report – Draft Environmental Impact Statement (DEIR/DEIS) for the East County Substation/Tule Wind/Energia Sierra Juarez Gen-Tie Projects." Comment letters and EIR/EIS revisions package from J. Durocher (Iberdrola Renewables) to I. Fisher (California Public Utilities Commission) and G. Thomsen (Bureau of Land Management). March 4, 2011.

Iberdrola Renewables, Inc. 2011b. "Re: Tule Wind Project – Groundwater Availability Confirmation Request." Letter from H. McDonald (Iberdrola Renewables) to J. Gibson (Hamann Companies). April 6, 2011.

Iberdrola Renewables, Inc. 2011c. "Re: Tule Wind Project – Groundwater Availability Confirmation Request." Letter from H. McDonald (Iberdrola Renewables) to W. Micklin (Ewiaapaayp Band of Kumeyaay Indians). April 8, 2011.

Iberdrola Renewables, Inc. 2011d. Response to Data Request 18. August 28, 2011.

Invenergy Wind California, LLC. 2010. Campo Wind Project – Response to Data Request No. 2.
Re: Campo Wind Project – CAISO Queue # 106A. June 16, 2010.

Lindenmeyer, T. 2010. Project Service Availability Form for the Tule Wind Project from the
Jacumba Community Service District (Thomas Lindenmeyer, General Manager).
August 10, 2010.

Najor, N. 2010. Project Service Availability Form for the Tule Wind Project for the Boulevard,
CA, area from the Live Oak Springs Water Company (Nazar Najor, Manager).
August 12, 2010.

Pacific Wind Development. 2009. Plan of Development: Tule Wind Project. October 2009.

~~Padoma Wind Power. 2010. Jordan Wind Project – Response to Data Request No. 1. Re: January
7, 2010 Letter from CPUC re: Padoma’s Jordan Wind Power Project. January 15, 2010.~~

SDG&E (San Diego Gas & Electric). 2009. PEA for the ECO Substation Project. August 2009.

SDG&E. 2010. Response to Data Request 11. Dated August 6, 2010.

SDG&E. 2011. Response to Data Request 15. August 26, 2011.

INTENTIONALLY LEFT BLANK

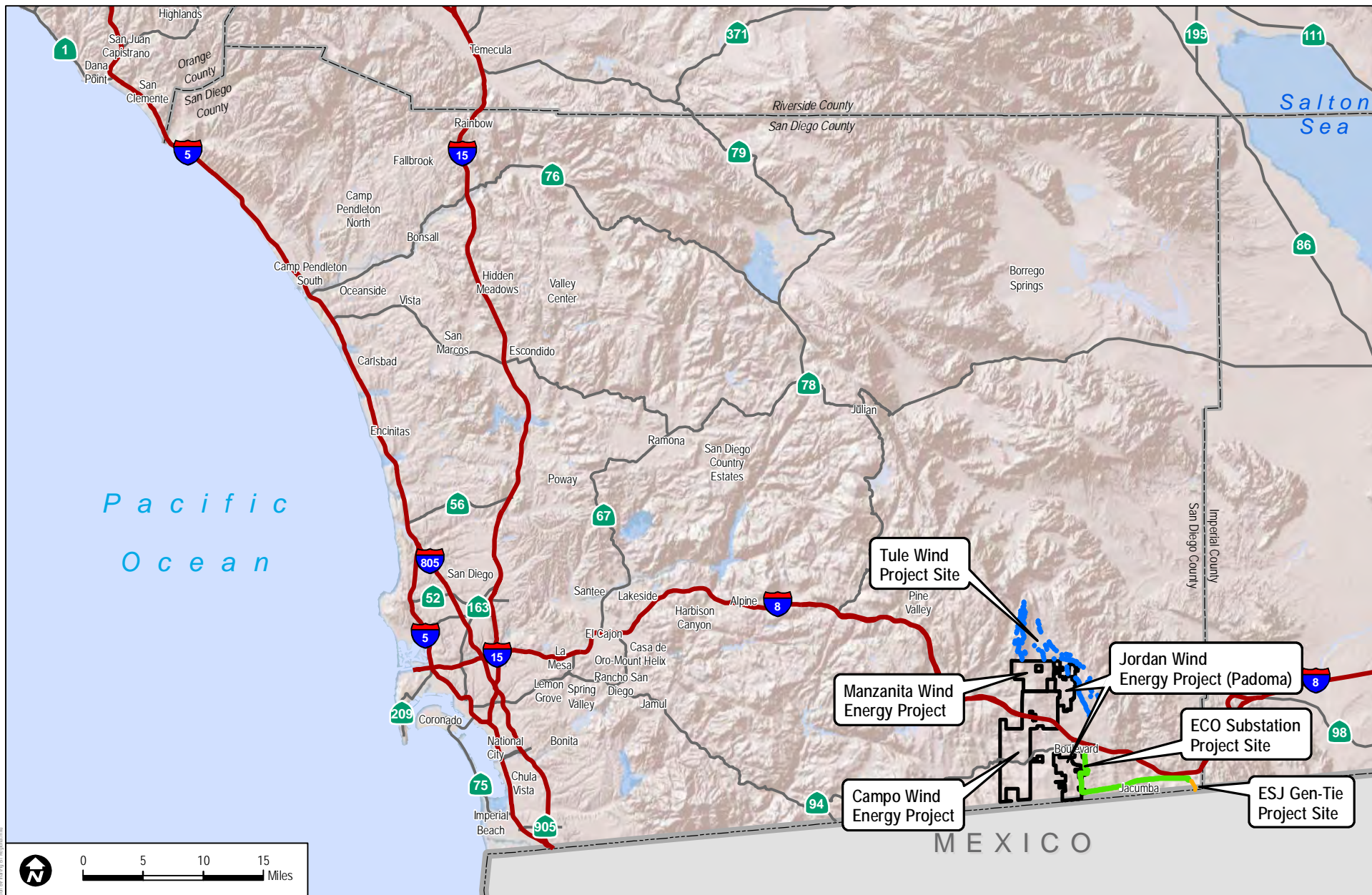

DUDEK

6168-01

East County Substation/Tule Wind/Energia Sierra Juarez Gen-Tie Projects - EIR/EIS

FIGURE B-1
Regional Map

INTENTIONALLY LEFT BLANK

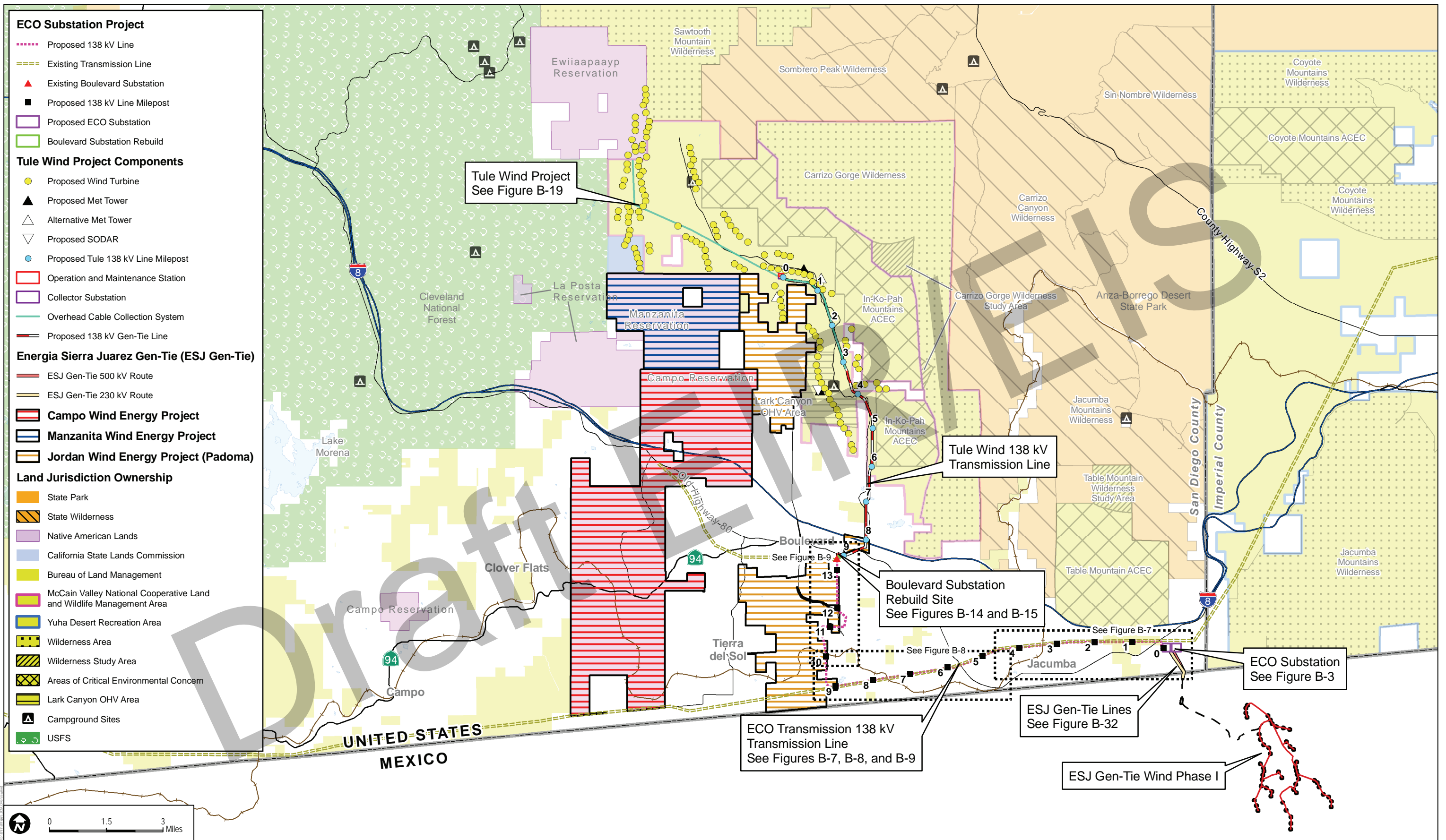

INTENTIONALLY LEFT BLANK

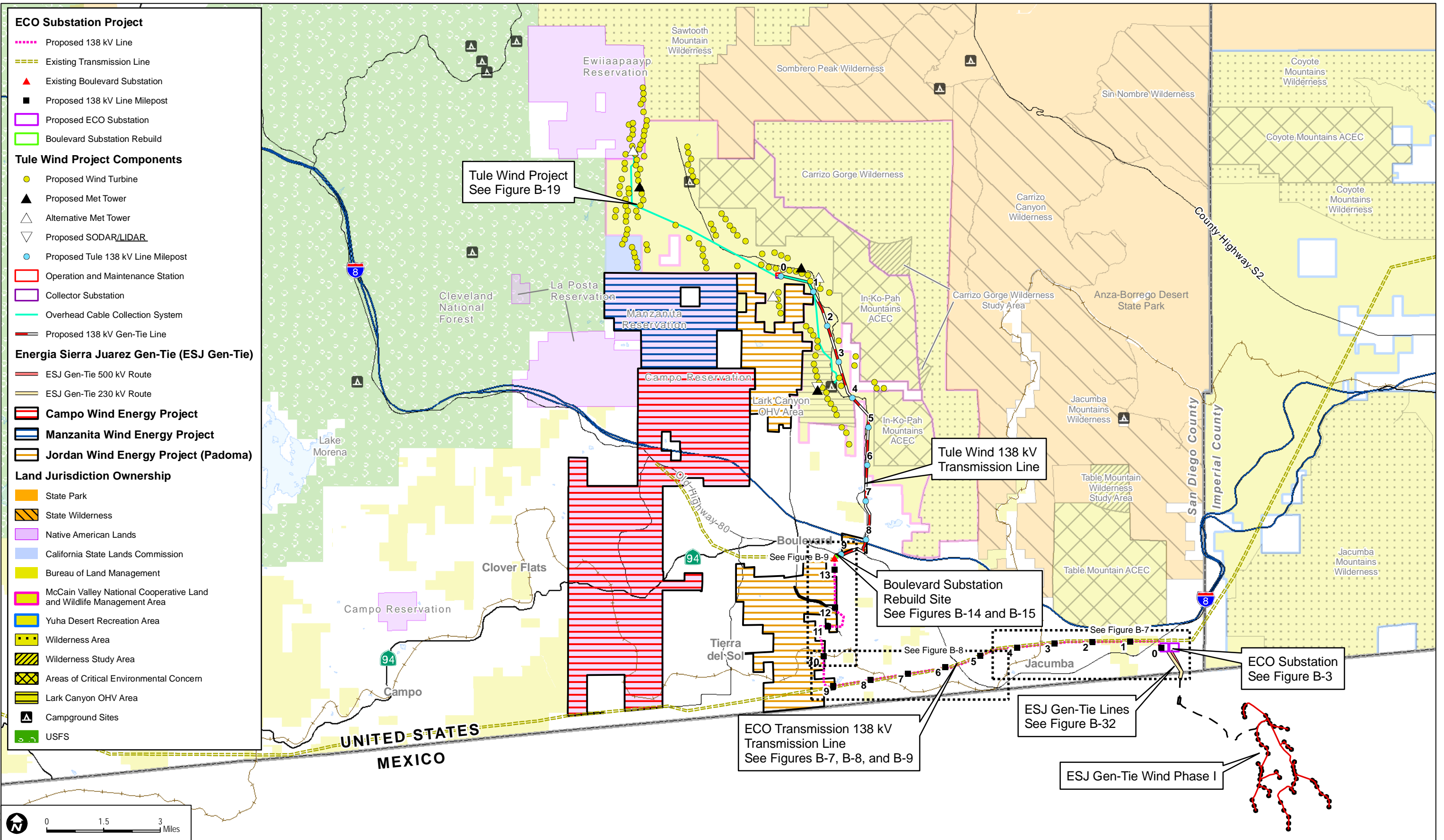

DUDEK

SOURCE: BLM; SanGIS; SANDAG; USFS; Tule Wind Project: HDR Engineering 2010; Iberdrola Renewables 2011
 ESJ U.S. Project: ENTRIX 2009; ESJ Wind Project: ENTRIX 2010;
 ECO Substation Project: SDG&E 2009

6168-01

East County Substation/Tule Wind/Energia Sierra Juarez Gen-Tie Projects - EIR/EIS

FIGURE B-2B
Vicinity/Overview Map

Note: Figure depicts the Tule Wind modified project layout

INTENTIONALLY LEFT BLANK

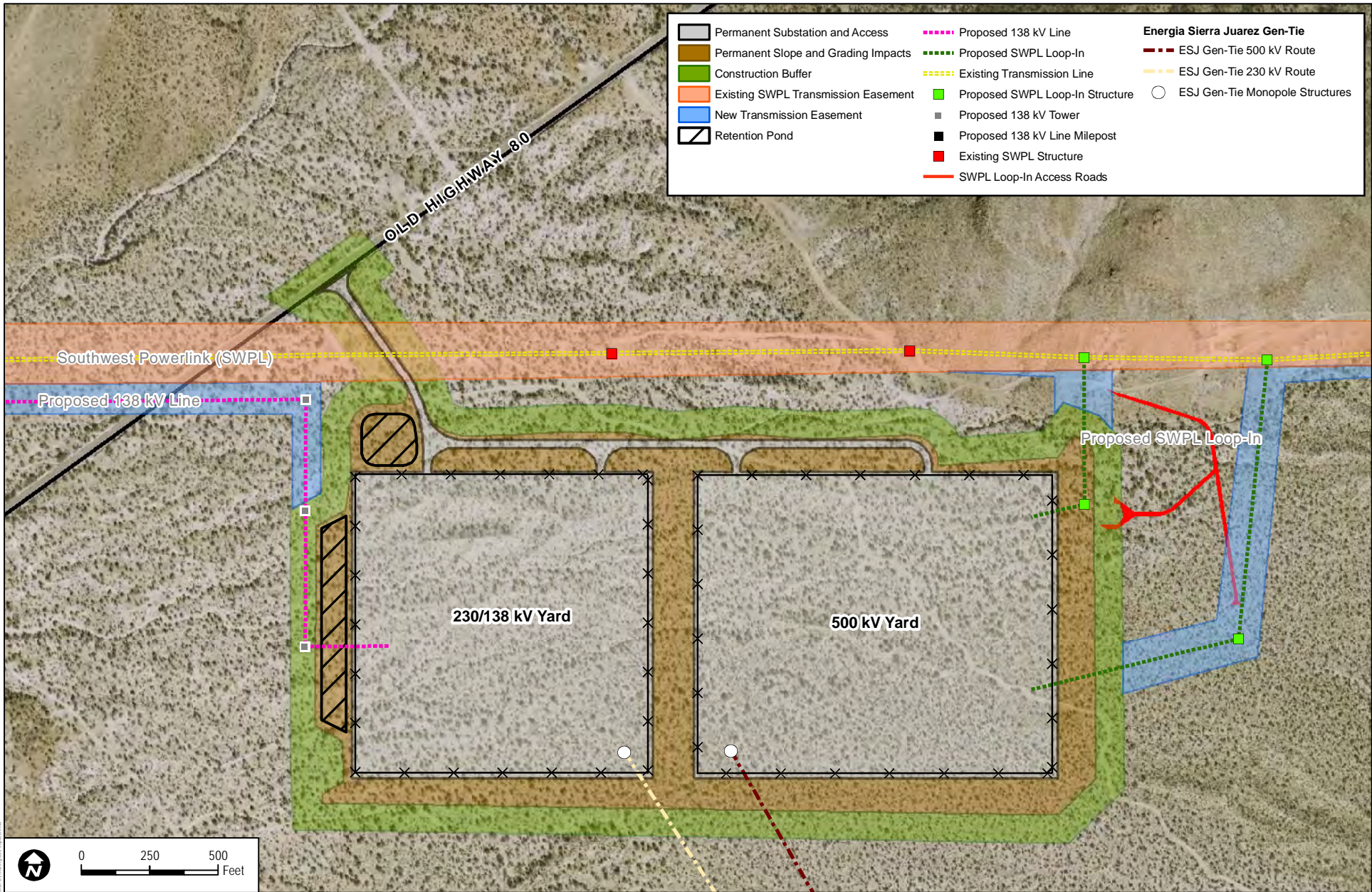

DUDEK

6168-01

SOURCE: SDGE 2009; Entrix 2010

East County Substation/Tule Wind/Energia Sierra Juarez Gen-Tie Projects - EIR/EIS

FIGURE B-3
ECO Substation Temporary and Permanent Footprint

INTENTIONALLY LEFT BLANK

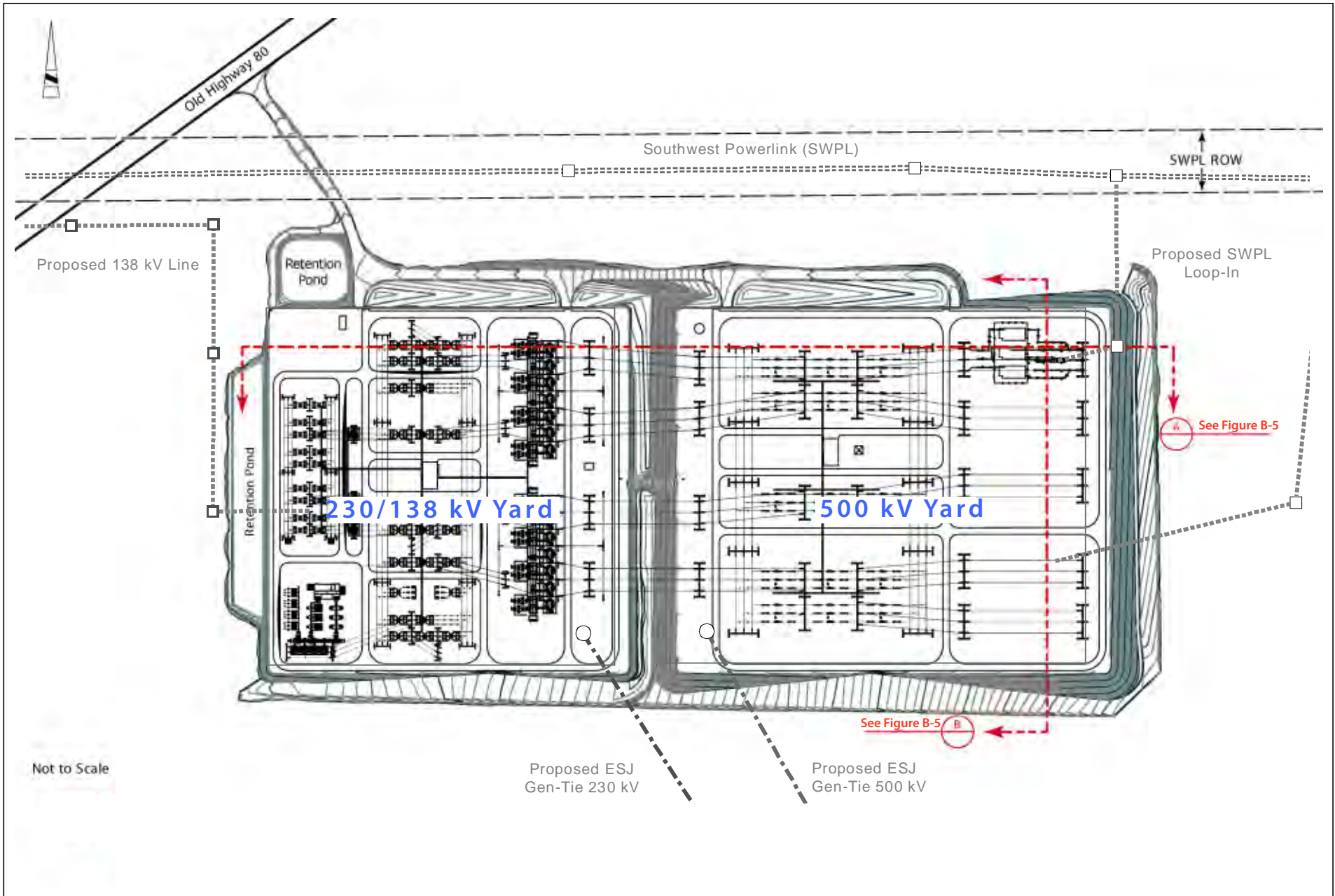

Not to Scale

DUDEK

SOURCE: SDG&E 2009

6168-01

East County Substation/Tule Wind/Energia Sierra Juarez Gen-Tie Projects EIR/EIS

**FIGURE B-4
ECO Substation Site Plan**

INTENTIONALLY LEFT BLANK

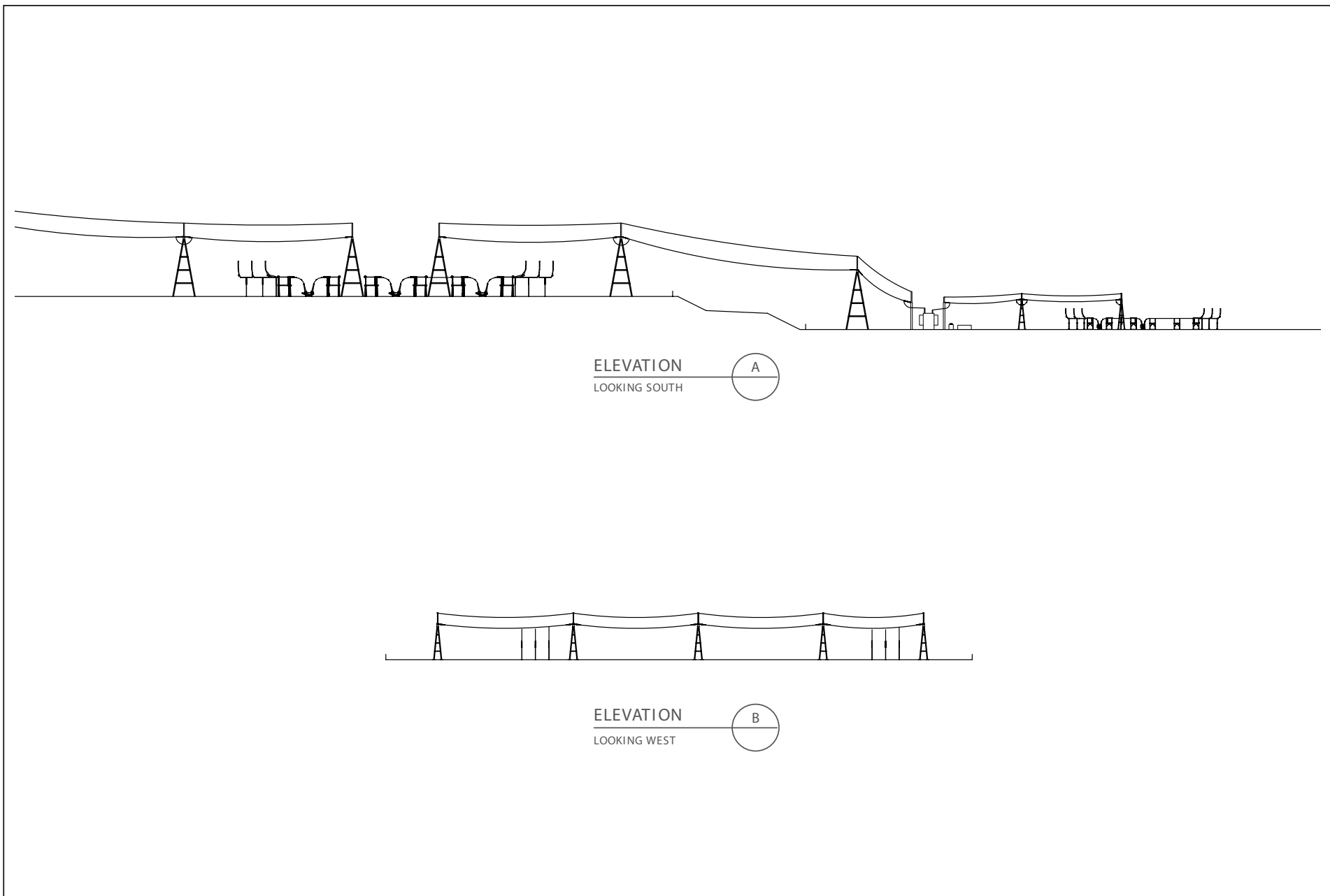

INTENTIONALLY LEFT BLANK

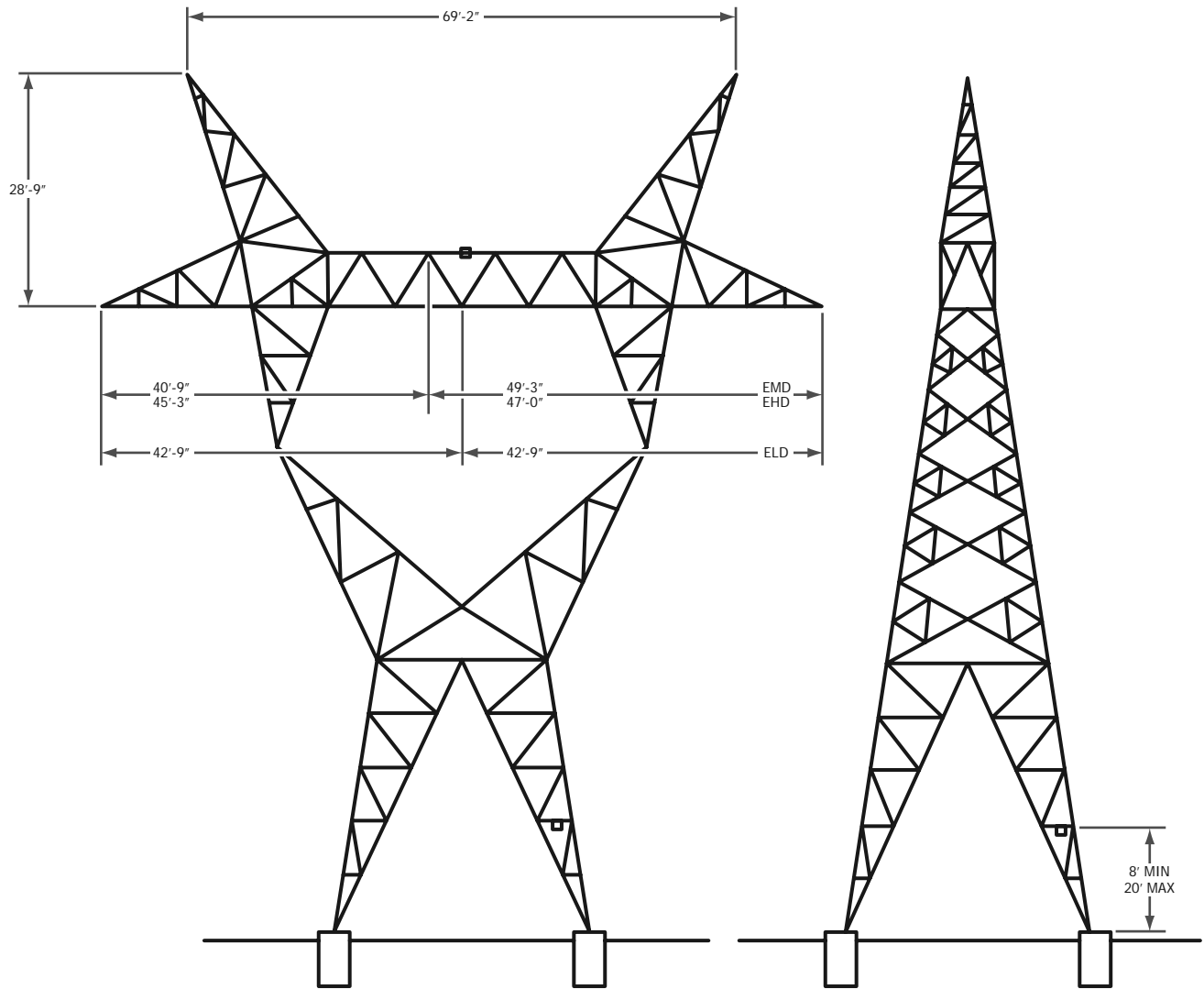

Z:\Projects\616801\WAPDOC\WAPS\EIR\EIS Figs

DUDEK

SOURCE: SDG&E 2009

FIGURE B-6

ECO Substation Project SWPL Loop-In Structure Typical Drawing

6168-01

East County Substation/Tule Wind/Energia Sierra Juarez Gen-Tie Projects EIR/EIS

INTENTIONALLY LEFT BLANK

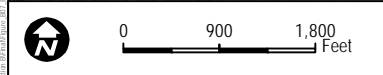
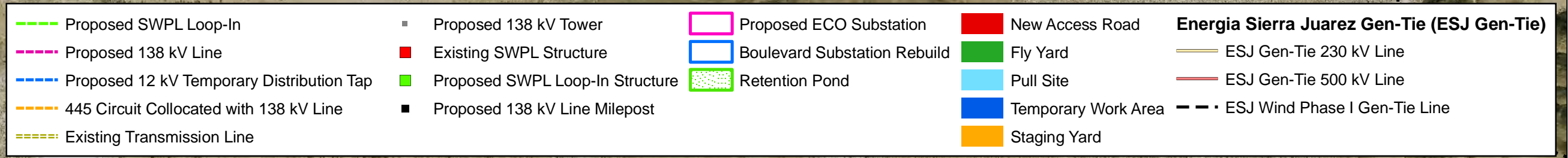
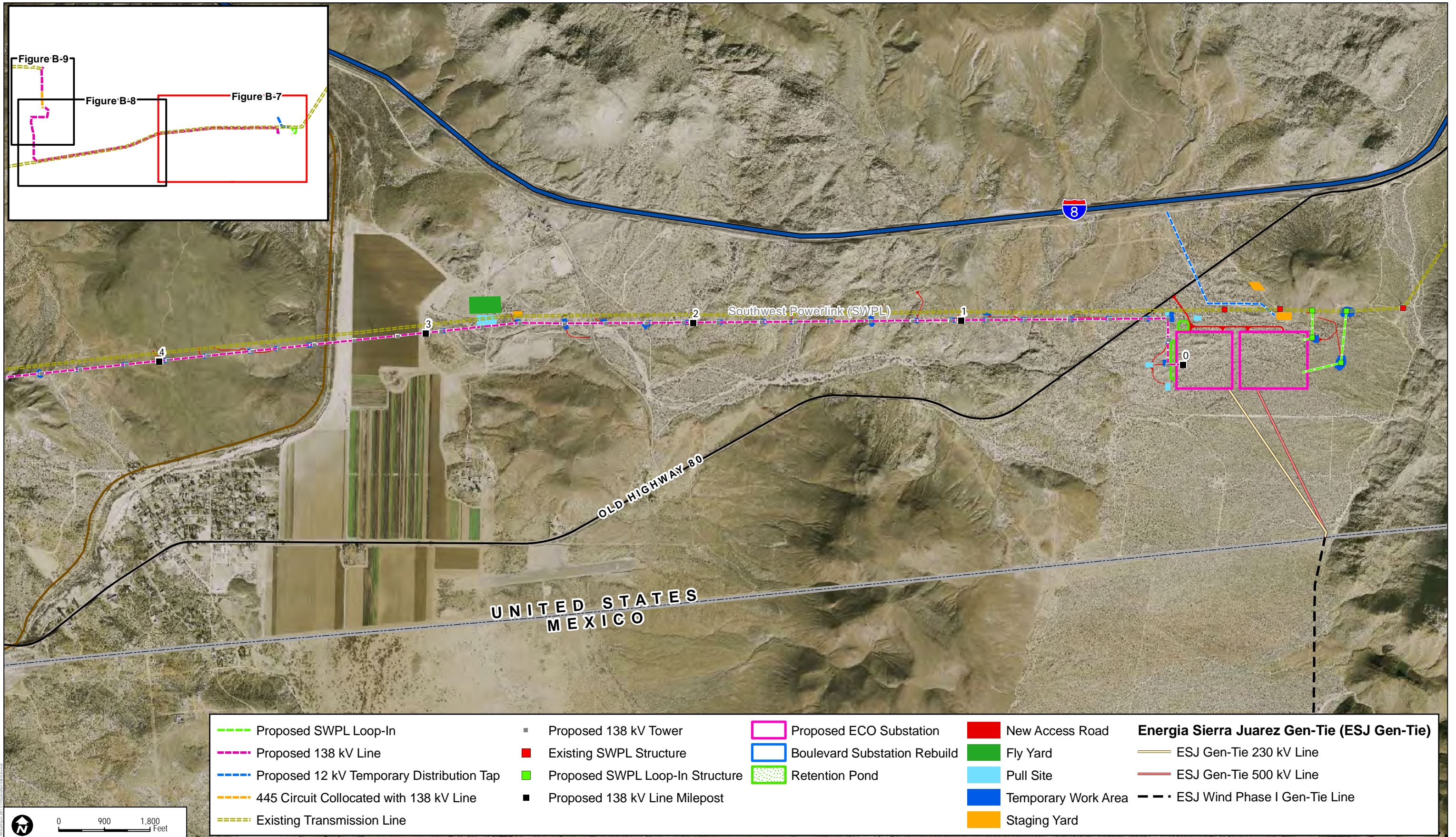

DUDEK

SOURCE: SDGE 2009

6168-01

East County Substation/Tule Wind/Energia Sierra Juarez Gen-Tie Projects - EIR/EIS

FIGURE B-7
ECO Substation Project Overhead 138 kV Transmission Line

INTENTIONALLY LEFT BLANK

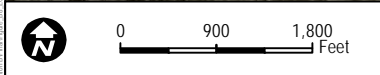
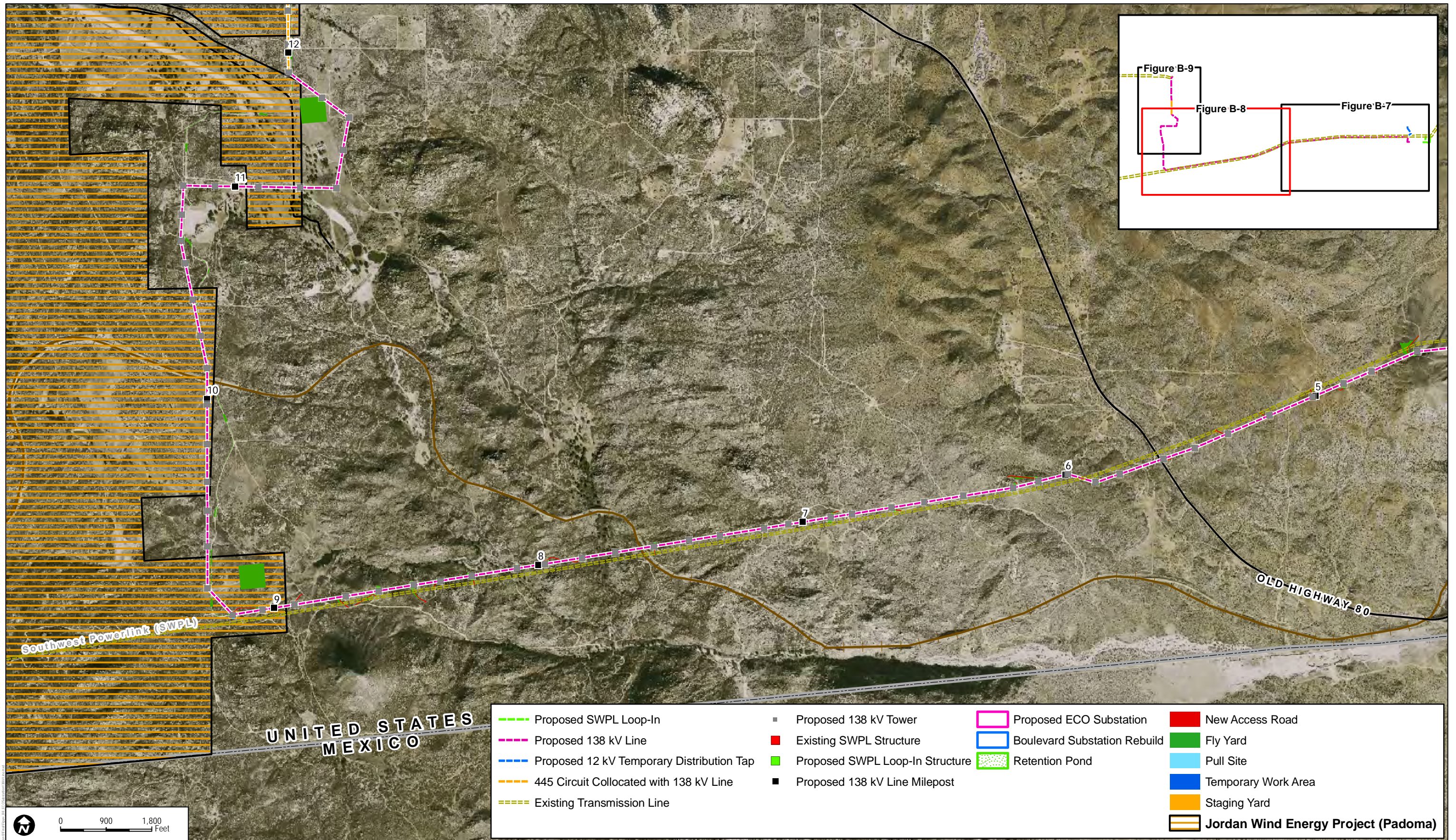

DUDEK

SOURCE: SDGE 2009

6168-01

East County Substation/Tule Wind/Energia Sierra Juarez Gen-Tie Projects - EIR/EIS

FIGURE B-8
ECO Substation Project Overhead 138 kV Transmission Line

INTENTIONALLY LEFT BLANK

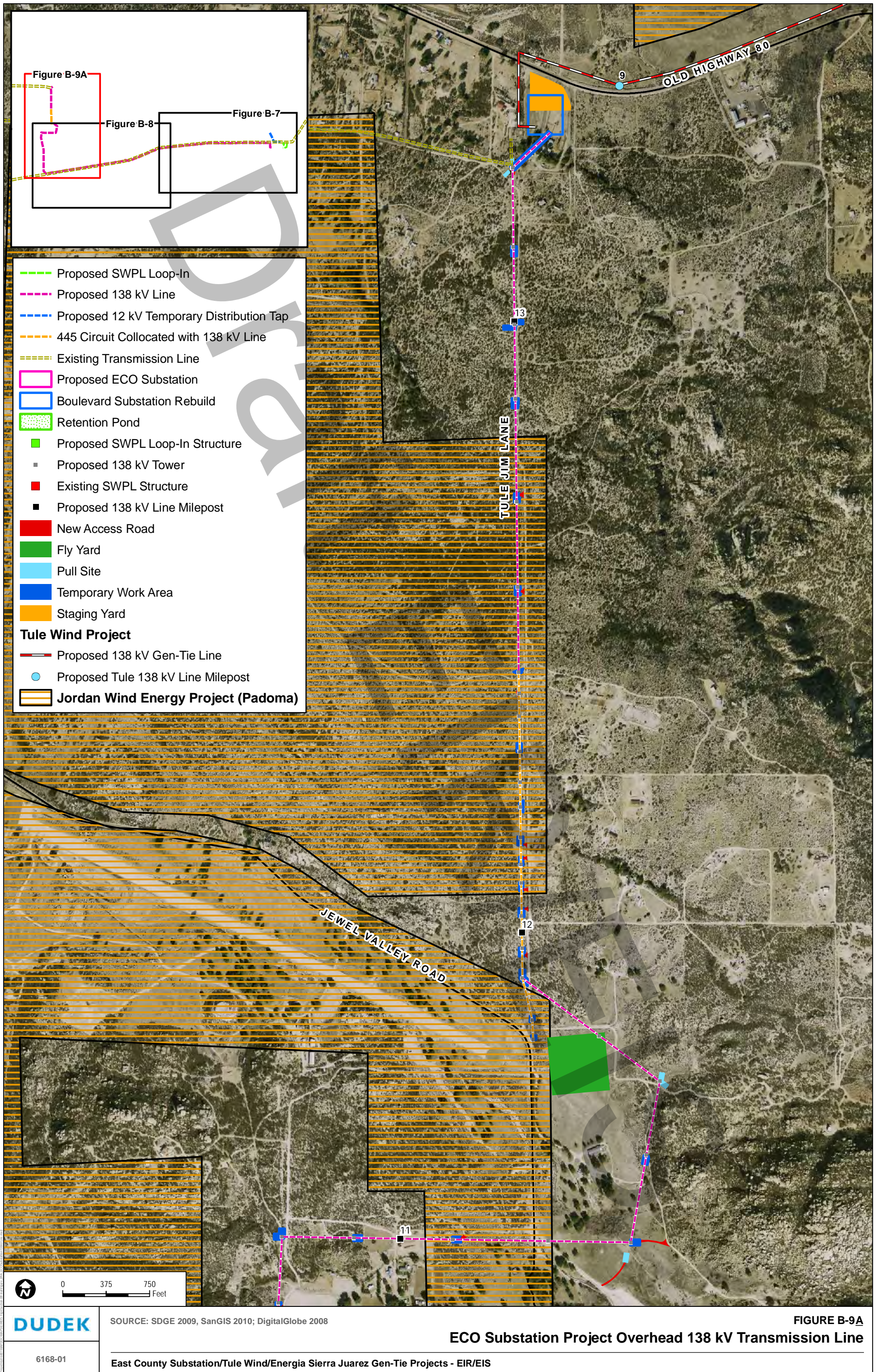

FIGURE B-9A

ECO Substation Project Overhead 138 kV Transmission Line

SOURCE: SDGE 2009, SanGIS 2010; DigitalGlobe 2008

East County Substation/Tule Wind/Energia Sierra Juarez Gen-Tie Projects - EIR/EIS

6168-01

INTENTIONALLY LEFT BLANK

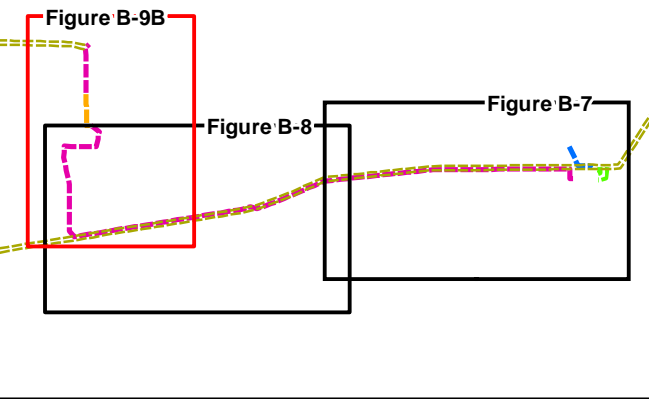
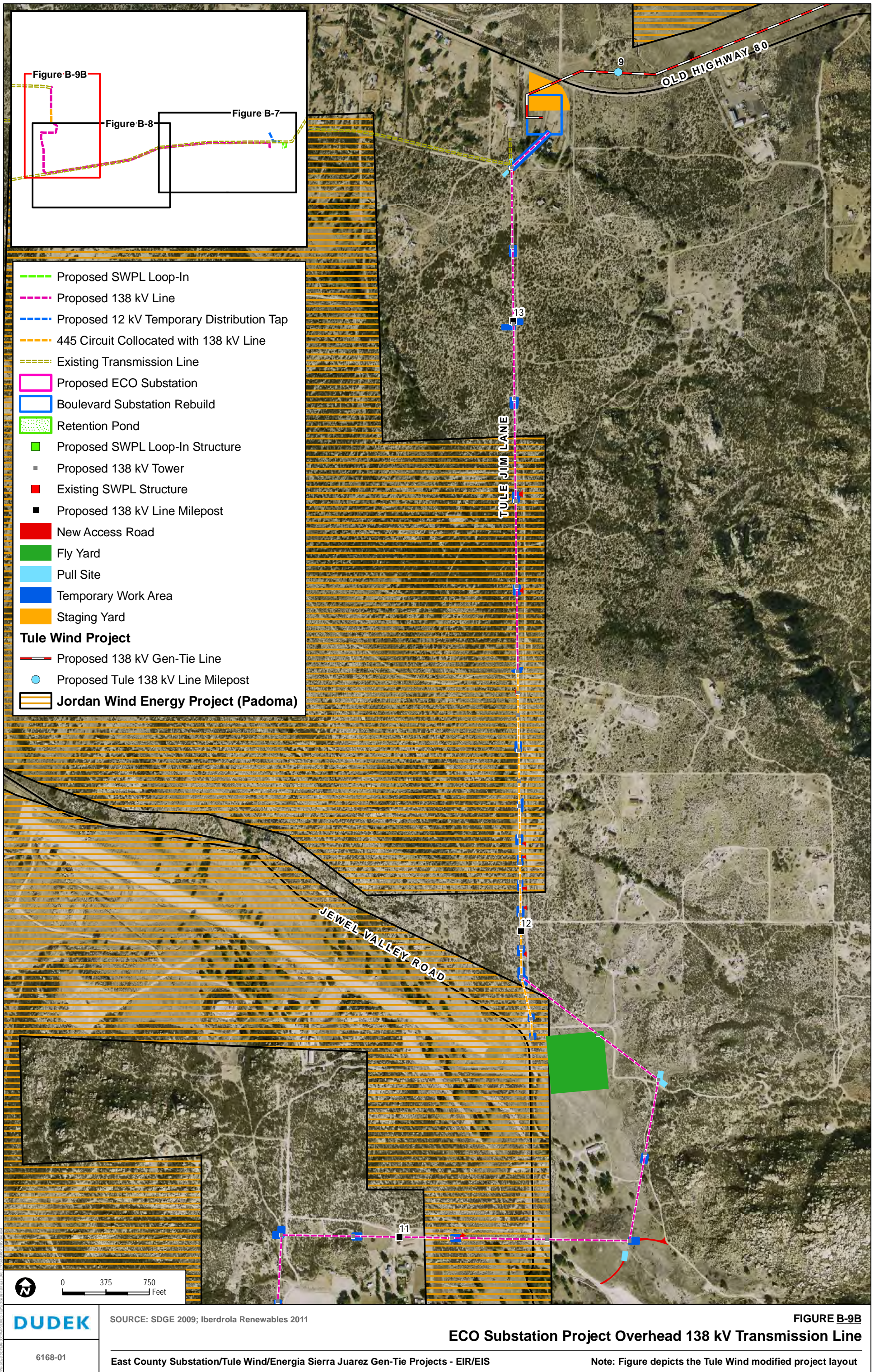

- Proposed SWPL Loop-In
- Proposed 138 kV Line
- Proposed 12 kV Temporary Distribution Tap
- 445 Circuit Collocated with 138 kV Line
- Existing Transmission Line
- Proposed ECO Substation
- Boulevard Substation Rebuild
- Retention Pond
- Proposed SWPL Loop-In Structure
- Proposed 138 kV Tower
- Existing SWPL Structure
- Proposed 138 kV Line Milepost
- New Access Road
- Fly Yard
- Pull Site
- Temporary Work Area
- Staging Yard
- Tule Wind Project**
- Proposed 138 kV Gen-Tie Line
- Proposed Tule 138 kV Line Milepost
- Jordan Wind Energy Project (Padoma)**

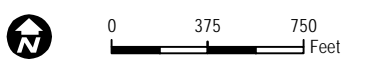

DUDEK
6168-01

SOURCE: SDGE 2009; Iberdrola Renewables 2011
East County Substation/Tule Wind/Energia Sierra Juarez Gen-Tie Projects - EIR/EIS

FIGURE B-9B
ECO Substation Project Overhead 138 kV Transmission Line
Note: Figure depicts the Tule Wind modified project layout

INTENTIONALLY LEFT BLANK

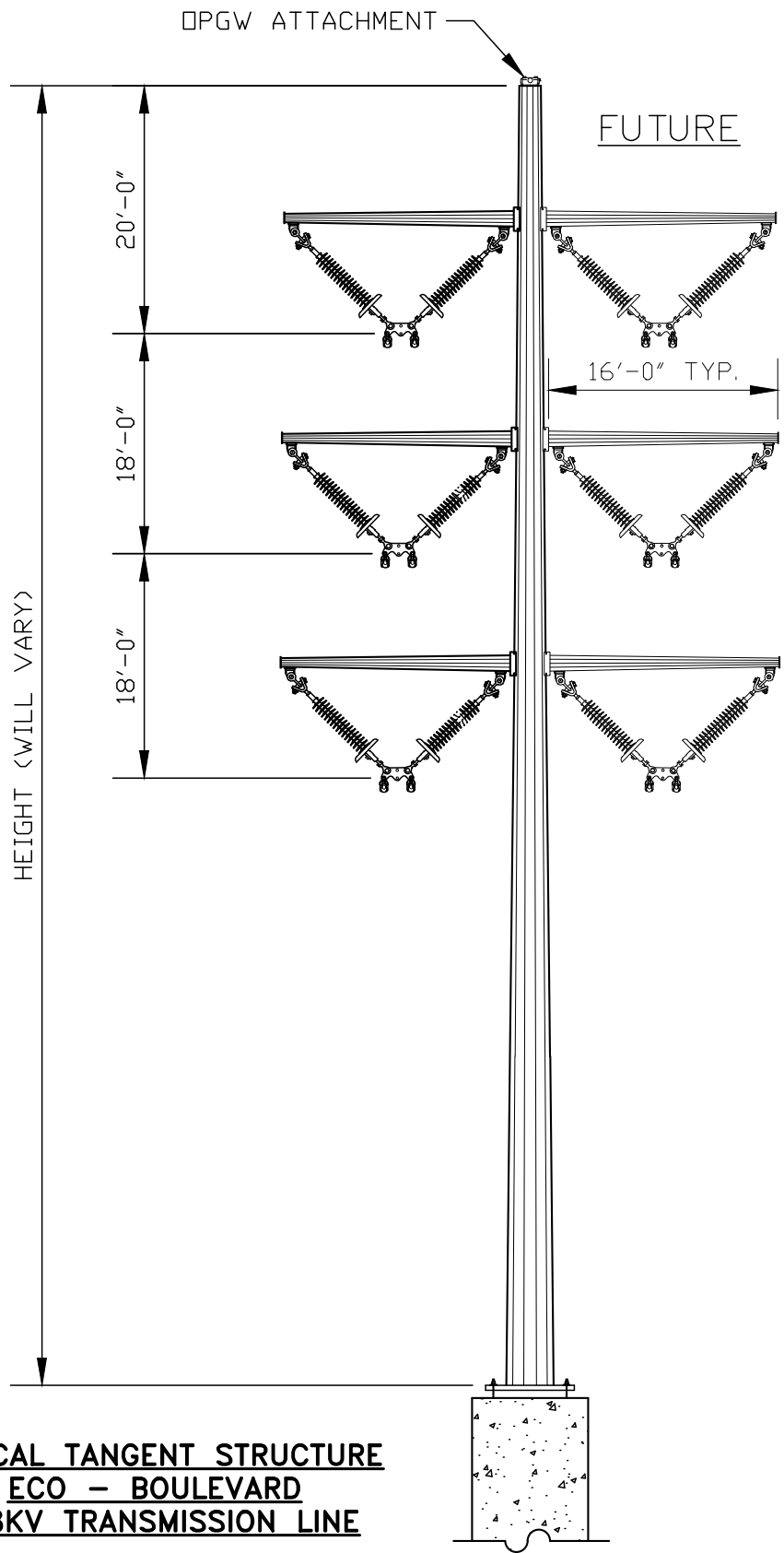

**TYPICAL TANGENT STRUCTURE
ECO – BOULEVARD
138KV TRANSMISSION LINE**

Z:\Projects\616801\WAPDOCC\WAPS\EIR\EIS Figs

DUDEK

SOURCE: SDG&E 2009

FIGURE B-10

ECO Substation Project 138 kV Steel Pole Typical Drawing

6168-01

East County Substation/Tule Wind/Energia Sierra Juarez Gen-Tie Projects EIR/EIS

INTENTIONALLY LEFT BLANK

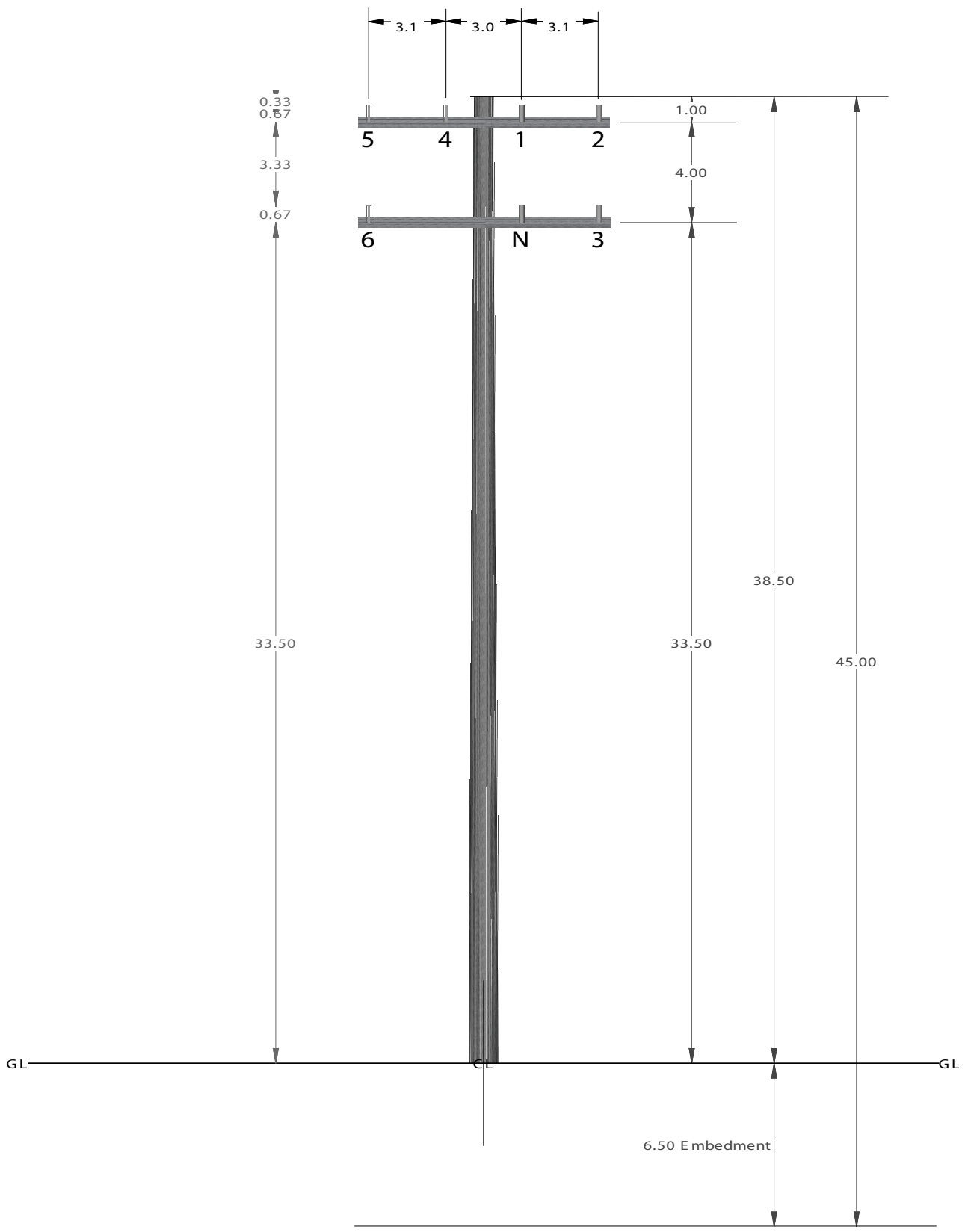

Z:\Projects\616801\WAPDOC\WAPS\IEIR\IEIS Figs

DUDEK

SOURCE: SDG&E 2009

FIGURE B-11

ECO Substation Project Typical Wooden Distribution Pole

6168-01

East County Substation/Tule Wind/Energia Sierra Juarez Gen-Tie Projects EIR/EIS

INTENTIONALLY LEFT BLANK

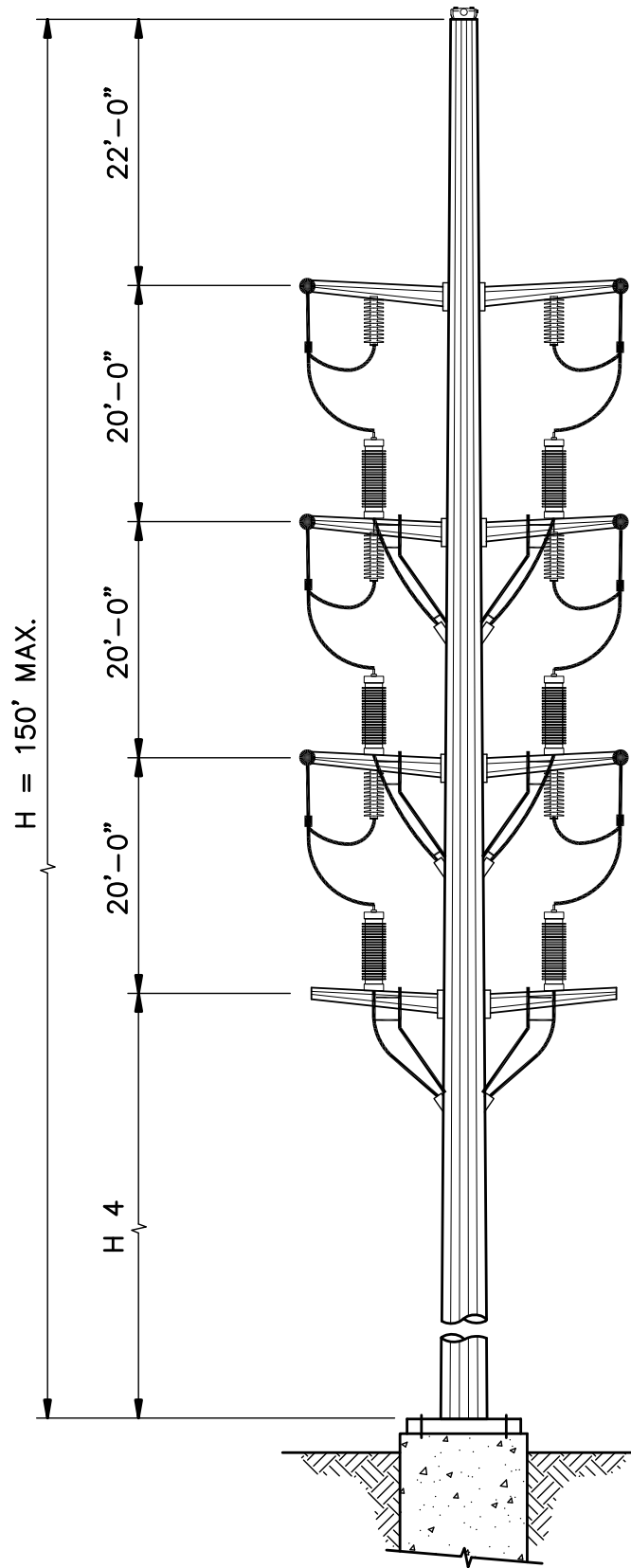

Z:\Projects\616801\WAPDOCC\WAPS\EIR\EIS Figs

DUDEK

SOURCE: SDG&E 2009

FIGURE B-12

ECO Substation Project Steel Cable Riser Pole Typical Drawing

6168-01

East County Substation/Tule Wind/Energia Sierra Juarez Gen-Tie Projects EIR/EIS

INTENTIONALLY LEFT BLANK

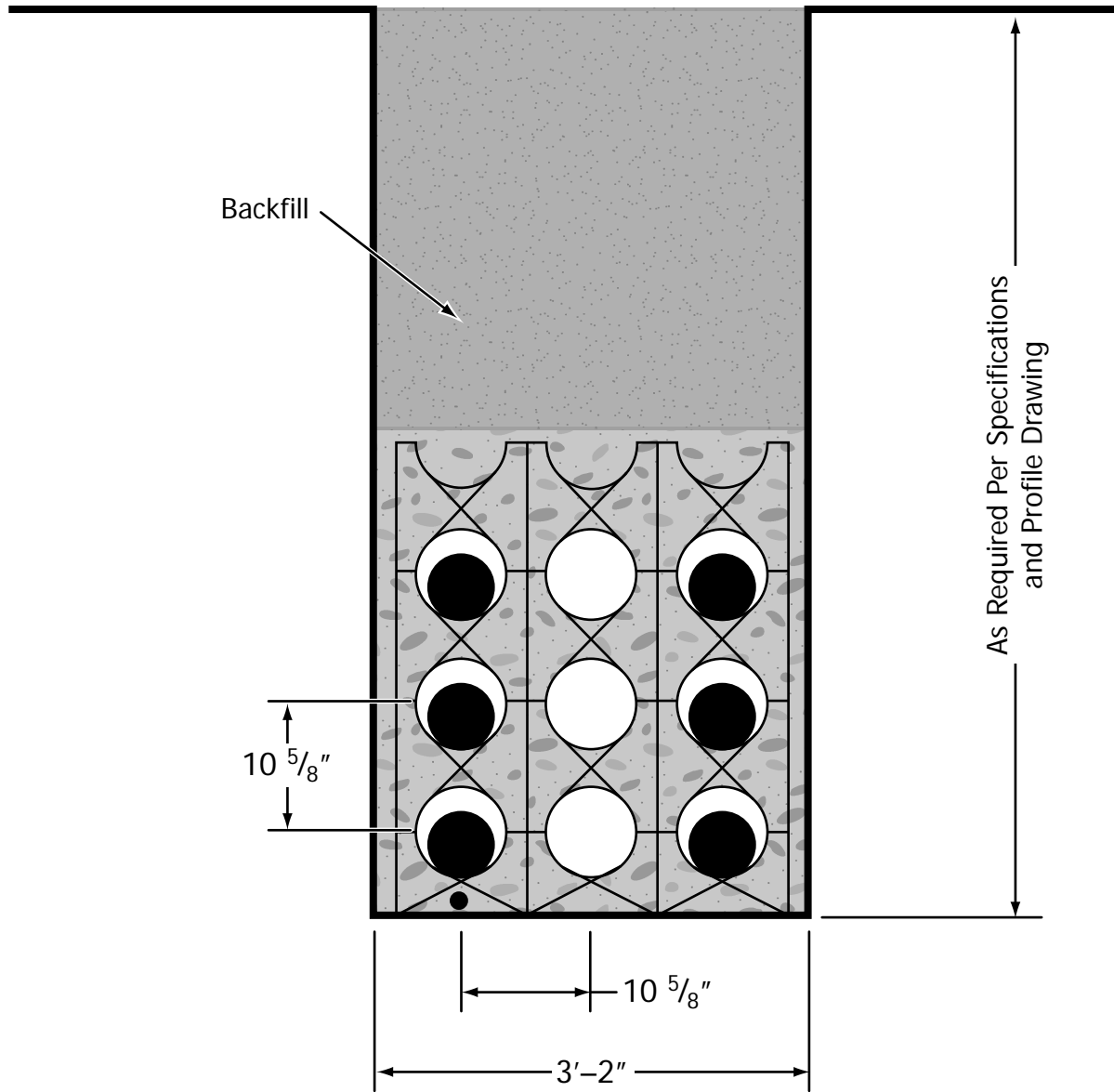

Z:\Projects\616801\WAPDOC\WAPSI\EIR\IS Figs\Section B

DUDEK

SOURCE: SDG&E 2009

FIGURE B-13

ECO Substation Project Underground 138 kV Concrete Duct Bank Typical Drawing

6168-01

East County Substation/Tule Wind/Energia Sierra Juarez Gen-Tie Projects EIR/EIS

INTENTIONALLY LEFT BLANK

INTENTIONALLY LEFT BLANK

INTENTIONALLY LEFT BLANK

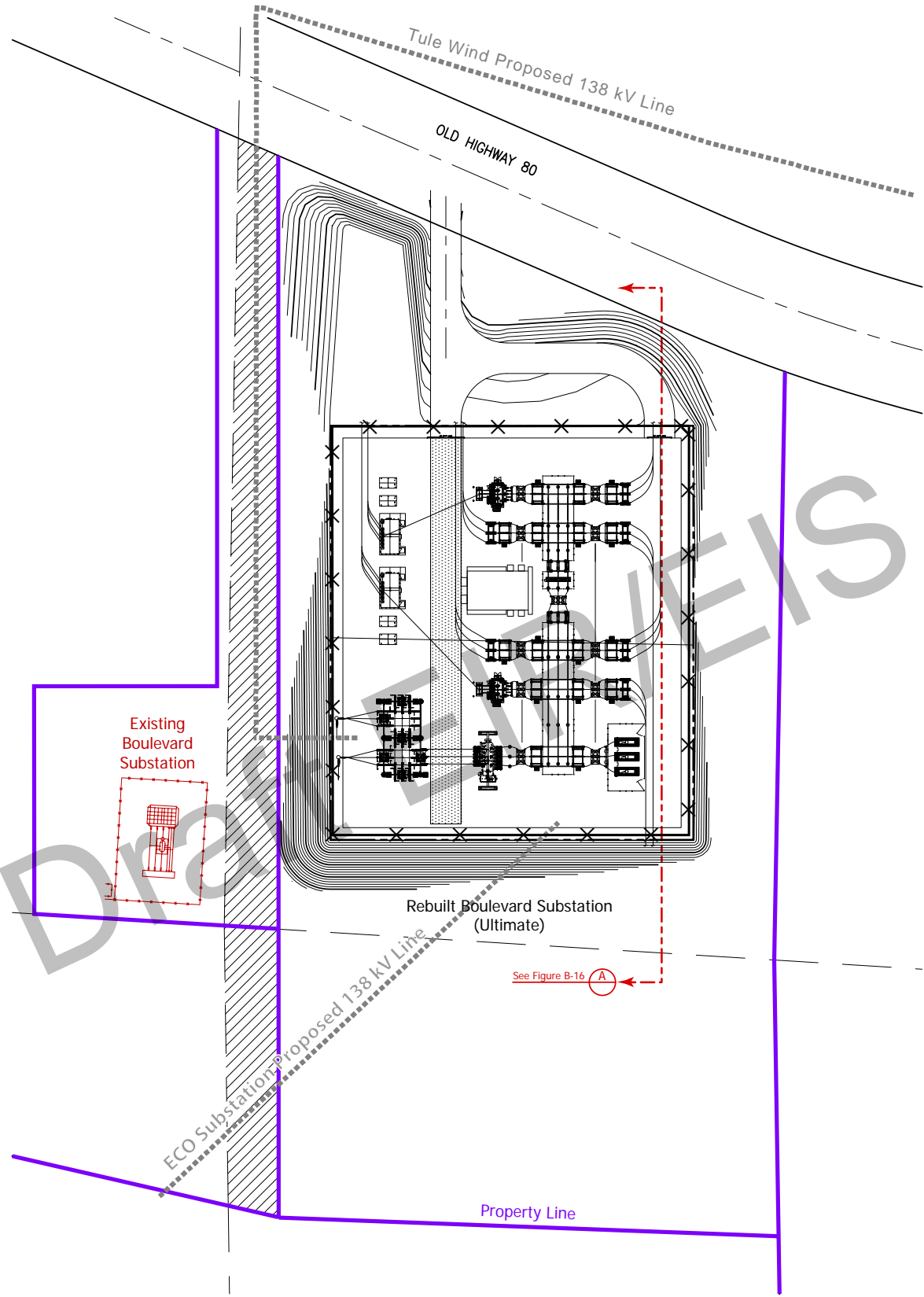

Z:\Projects\616801\WAPDOCC\WAPS\EIR/EIS Figs\Section B

DUDEK

SOURCE: SDG&E 2009

FIGURE B-15A

ECO Substation Project Boulevard Substation Rebuild

6168-01

East County Substation/Tule Wind/Energia Sierra Juarez Gen-Tie Projects EIR/EIS

INTENTIONALLY LEFT BLANK

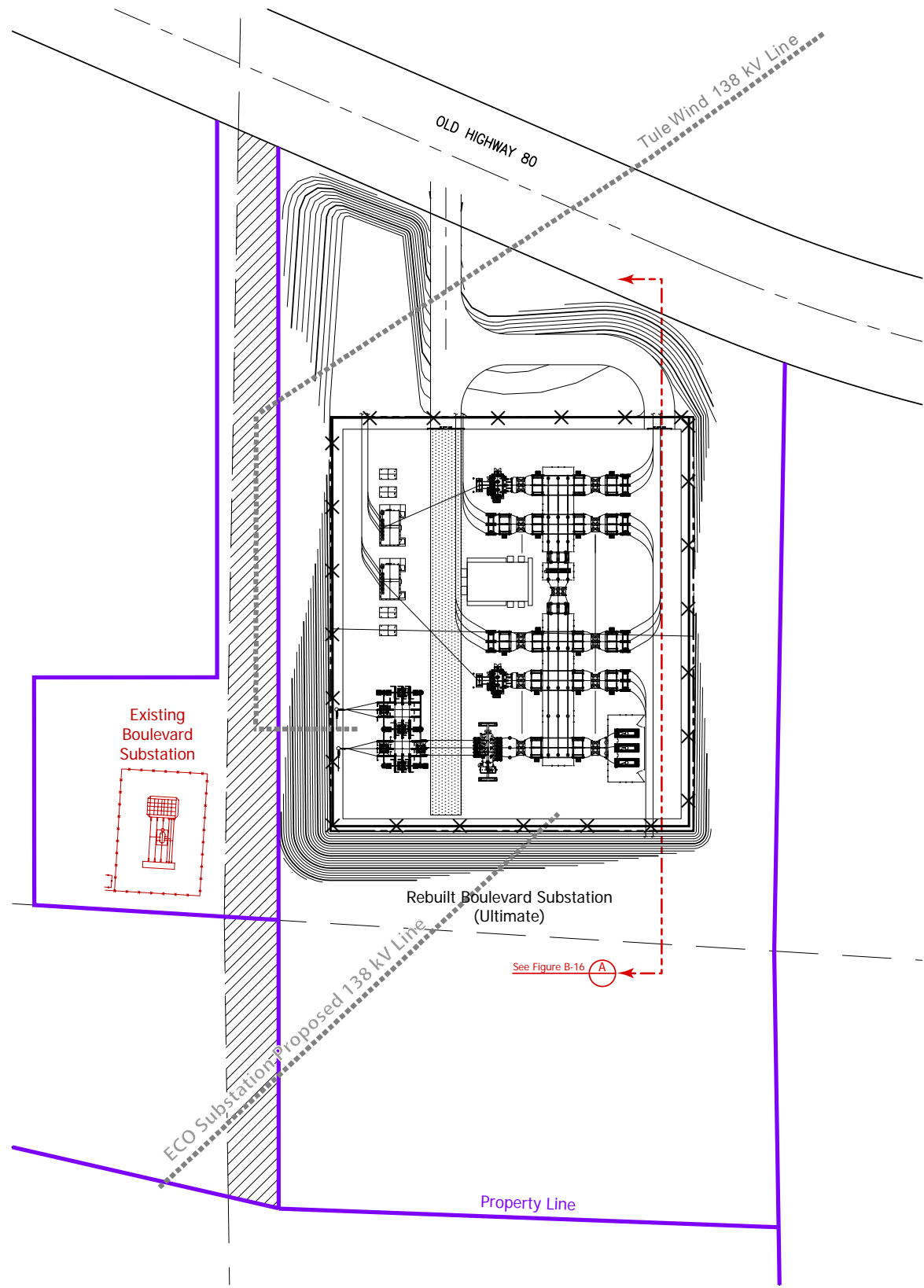

Note: Figure depicts Tule Wind modified project layout.

DUDEK

SOURCE: SDG&E 2009; IBERDROLA RENEWABLES 2011

FIGURE B-15B

ECO Substation Project Boulevard Substation Rebuild

6168-01

East County Substation/Tule Wind/Energia Sierra Juarez Gen-Tie Projects EIR/EIS

Z:\Projects\616801\MAPDOC\MAPS\EIR\EIS Figs\Section B

INTENTIONALLY LEFT BLANK

Z:\Projects\616801\MAPDOC\MAPS\EIR\EIS Figs

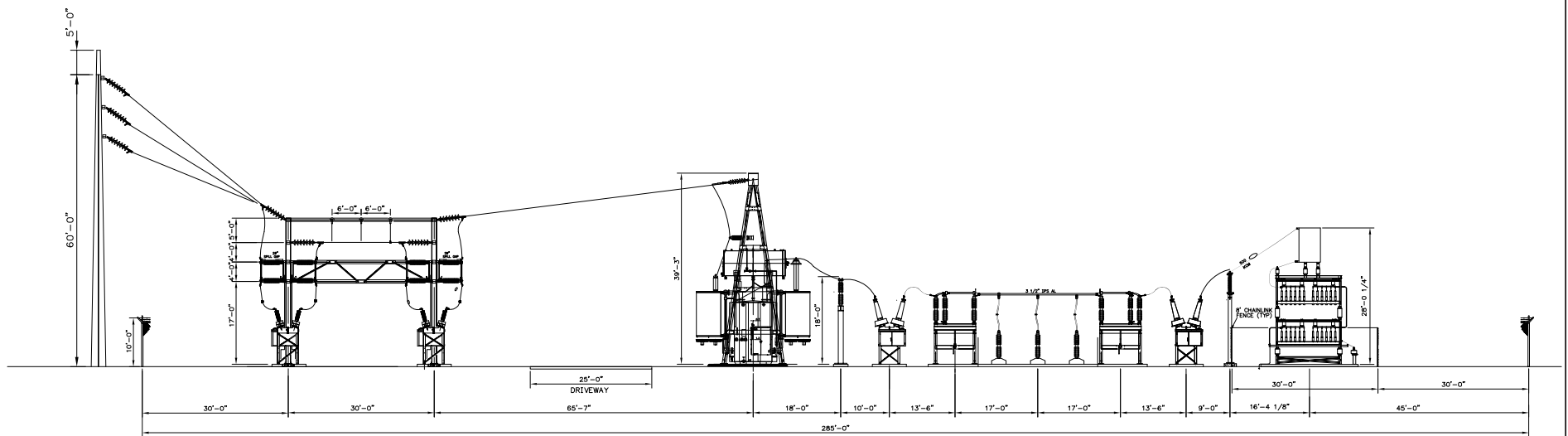

ELEVATION A
Looking West

DUDEK

SOURCE: SDG&E 2009

FIGURE B-16

ECO Substation Project Boulevard Substation Profile Drawing

6168-01

East County Substation/Tule Wind/Energia Sierra Juarez Gen-Tie Projects EIR/EIS

INTENTIONALLY LEFT BLANK

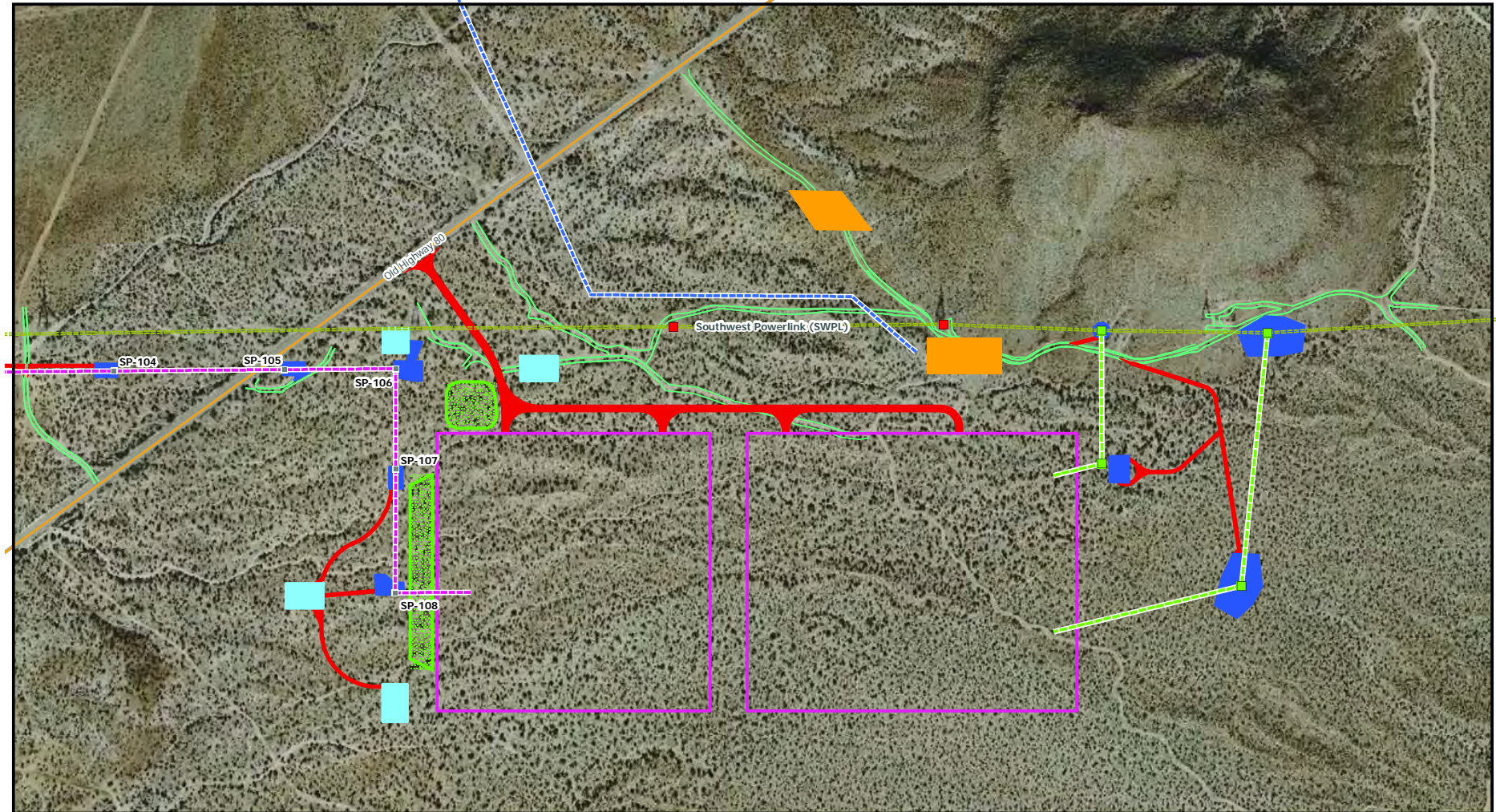

ECO Substation and SWPL Loop-In Vicinity Map

East County Substation Project

- | | | | |
|---|---------------------------------|---------------------|------------|
| Proposed SWPL Loop-In | Proposed ECO Substation | New Access Road | Major Road |
| Proposed 138 kV Line | Retention Pond | Pull Site | Interstate |
| Proposed 12 kV Temporary Distribution Tap | Existing SWPL Structure | Temporary Work Area | Highway |
| Existing Transmission Line | Proposed SWPL Loop-In Structure | Staging Yard | Railroad |
| Proposed 138 kV Tower | Existing Access Road | | |

Note: The Proposed Project facilities and work areas depicted are based on preliminary engineering data and are subject to change or refinement.

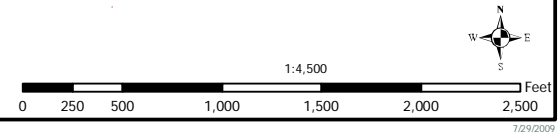

DUDEK

SOURCE: SDG&E 2009

FIGURE B-17

ECO Substation and SWPL Loop-In Temporary Workspace Areas

6168-01

East County Substation/Tule Wind/Energia Sierra Juarez Gen-Tie Projects EIR/EIS

Z:\Projects\616801\MAPDOC\MAPS\EIR\EIS_Figs

INTENTIONALLY LEFT BLANK

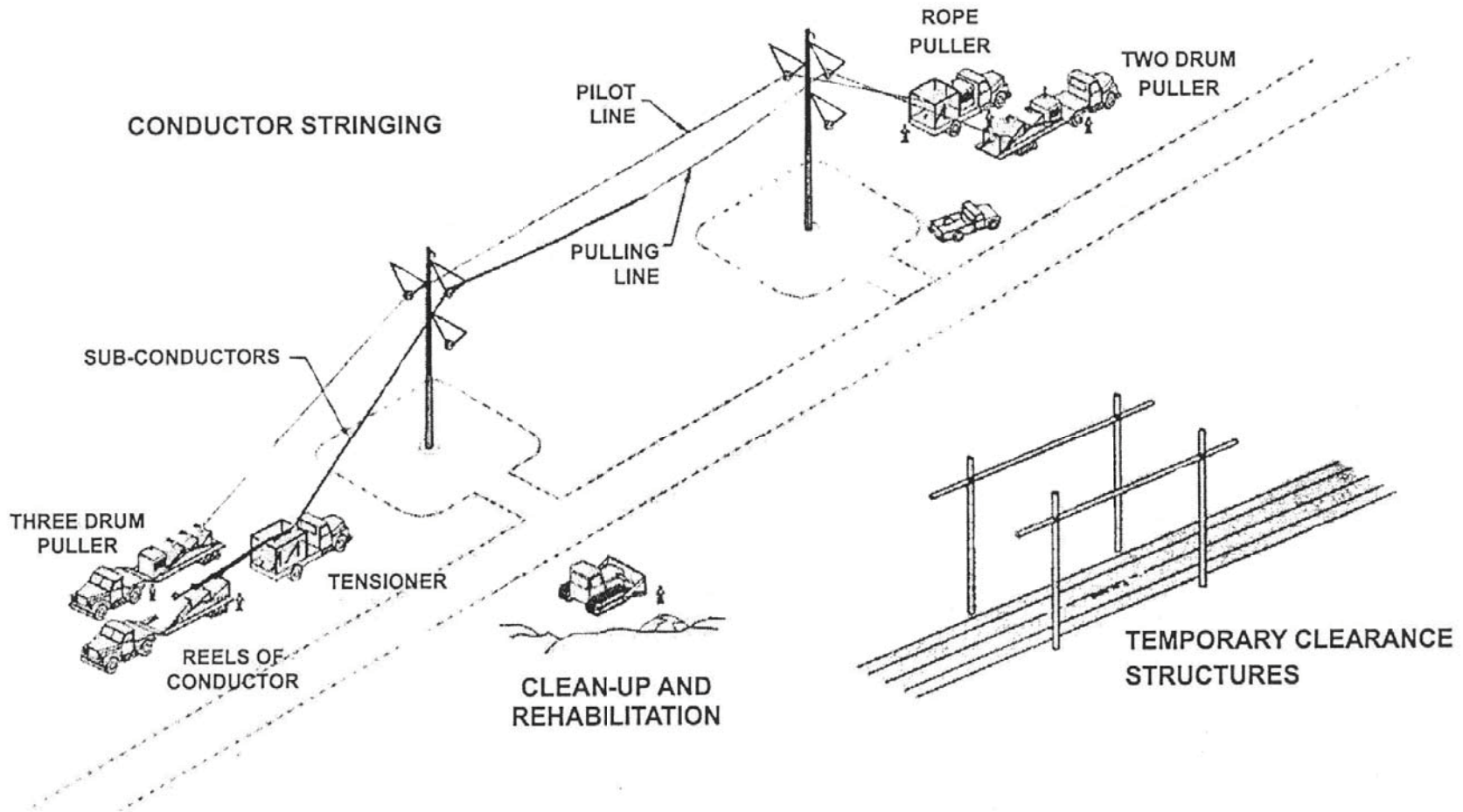

INTENTIONALLY LEFT BLANK

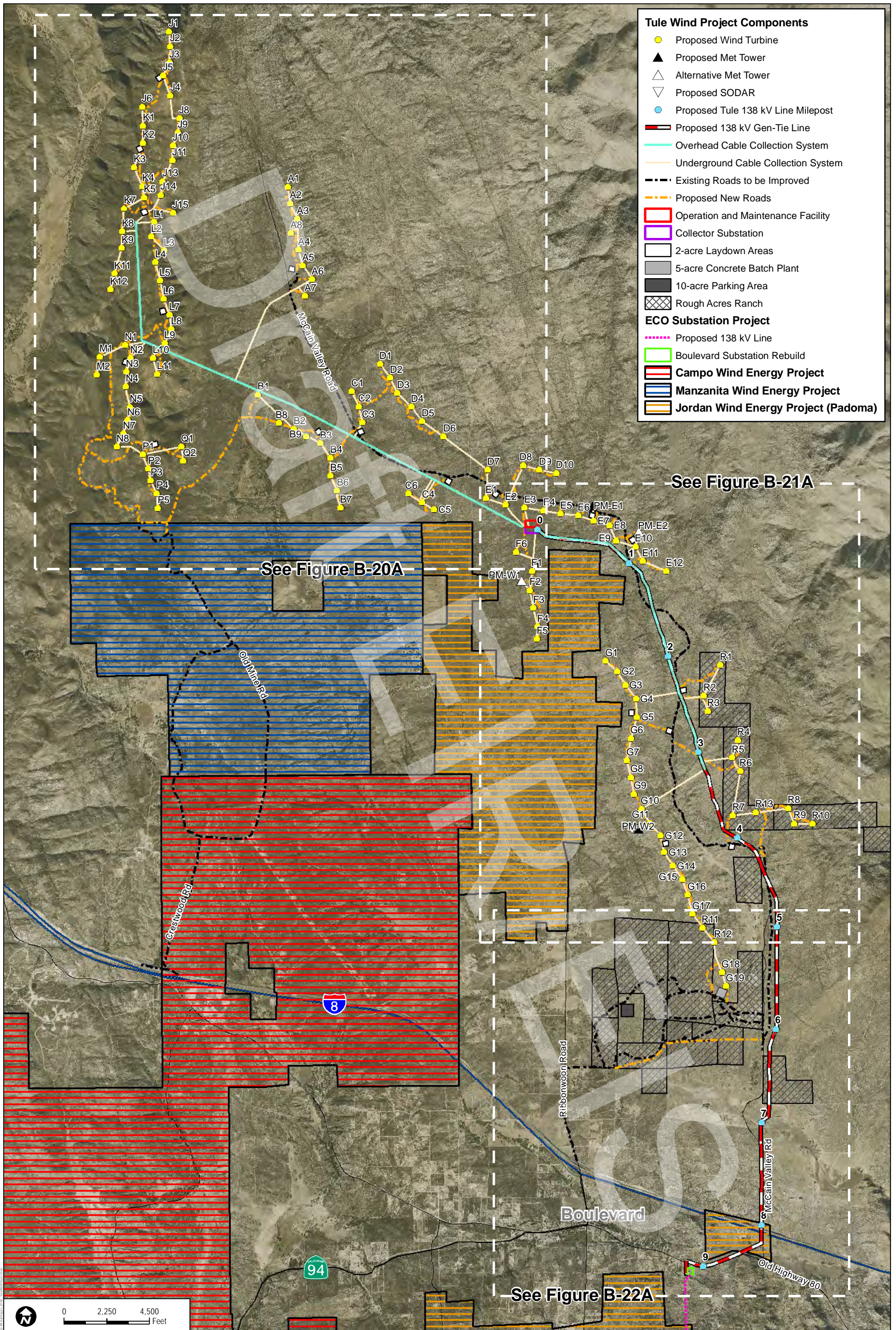

Tule Wind Project Components

- Proposed Wind Turbine
 - ▲ Proposed Met Tower
 - △ Alternative Met Tower
 - ▽ Proposed SODAR
 - Proposed Tule 138 kV Line Milepost
 - Proposed 138 kV Gen-Tie Line
 - Overhead Cable Collection System
 - Underground Cable Collection System
 - Existing Roads to be Improved
 - Proposed New Roads
 - Operation and Maintenance Facility
 - Collector Substation
 - 2-acre Laydown Areas
 - 5-acre Concrete Batch Plant
 - 10-acre Parking Area
 - ▨ Rough Acres Ranch
- ECO Substation Project**
- Proposed 138 kV Line
 - Boulevard Substation Rebuild
- Other Energy Projects**
- ▨ Campo Wind Energy Project
 - ▨ Manzanita Wind Energy Project
 - ▨ Jordan Wind Energy Project (Padoma)

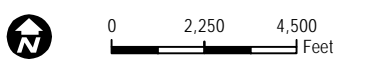

DUDEK

SOURCE: HDR 2010; SanGIS 2010; DigitalGlobe 2008

FIGURE B-19A

Tule Wind Project Overview

6168-01

INTENTIONALLY LEFT BLANK

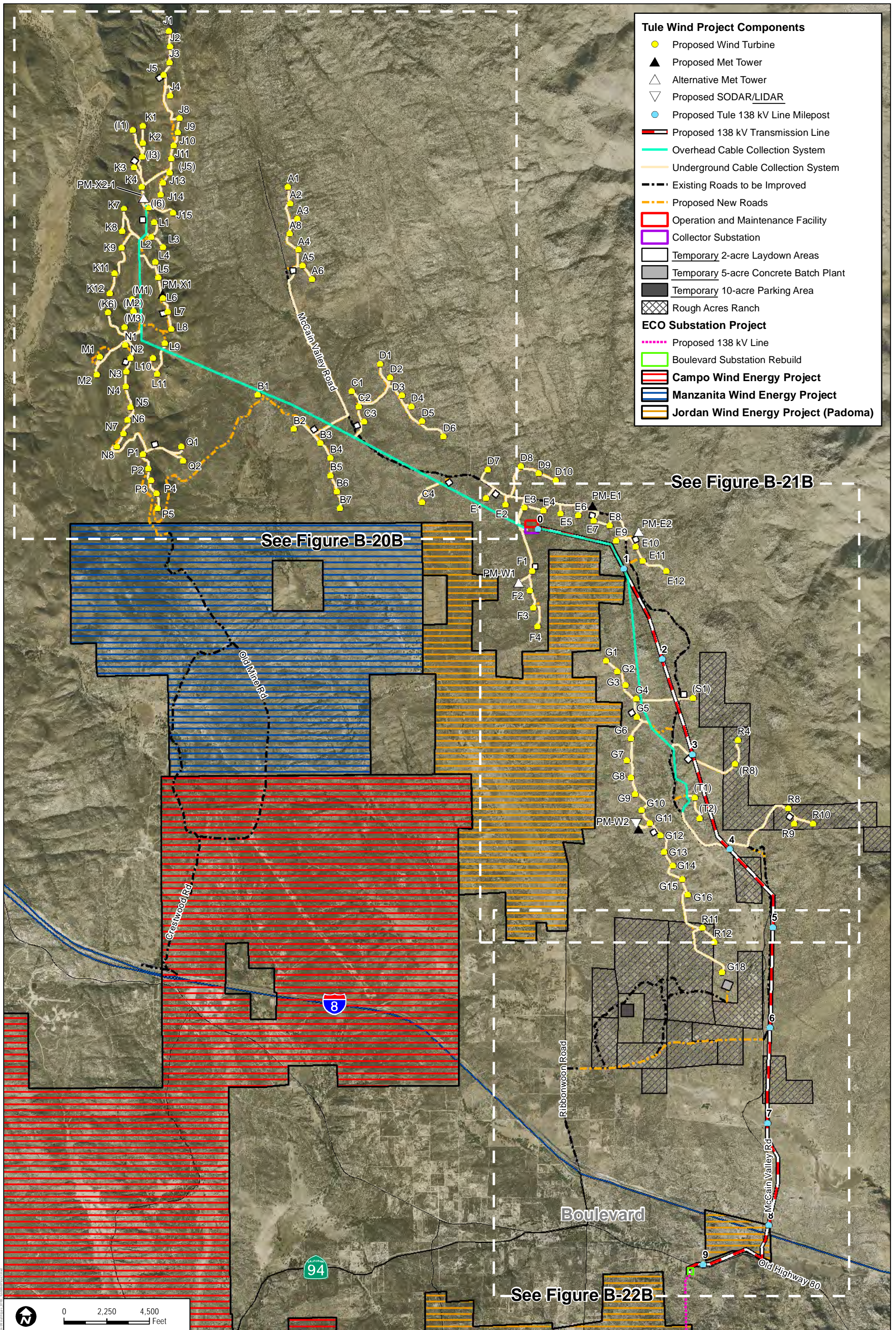

- Tule Wind Project Components**
- Proposed Wind Turbine
 - ▲ Proposed Met Tower
 - △ Alternative Met Tower
 - ▽ Proposed SODAR/LIDAR
 - Proposed Tule 138 kV Line Milepost
 - Proposed 138 kV Transmission Line
 - Overhead Cable Collection System
 - Underground Cable Collection System
 - - - Existing Roads to be Improved
 - - - Proposed New Roads
 - Operation and Maintenance Facility
 - Collector Substation
 - Temporary 2-acre Laydown Areas
 - Temporary 5-acre Concrete Batch Plant
 - Temporary 10-acre Parking Area
 - ▨ Rough Acres Ranch
- ECO Substation Project**
- Proposed 138 kV Line
 - Boulevard Substation Rebuild
- Wind Energy Projects**
- ▨ Campo Wind Energy Project
 - ▨ Manzanita Wind Energy Project
 - ▨ Jordan Wind Energy Project (Padoma)

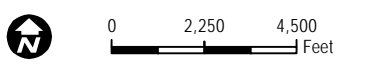

DUDEK

SOURCE: HDR 2010; Iberdrola Renewable 2011

FIGURE B-19B

Tule Wind Project Overview

6168-01

East County Substation/Tule Wind/Energia Sierra Juarez Gen-Tie Projects - EIR/EIS

Notes: 1) Figure depicts the Tule Wind modified project layout and 2) Draft EIR/EIS turbine numbering has been retained (modified turbine numbering shown in parenthesis).

INTENTIONALLY LEFT BLANK

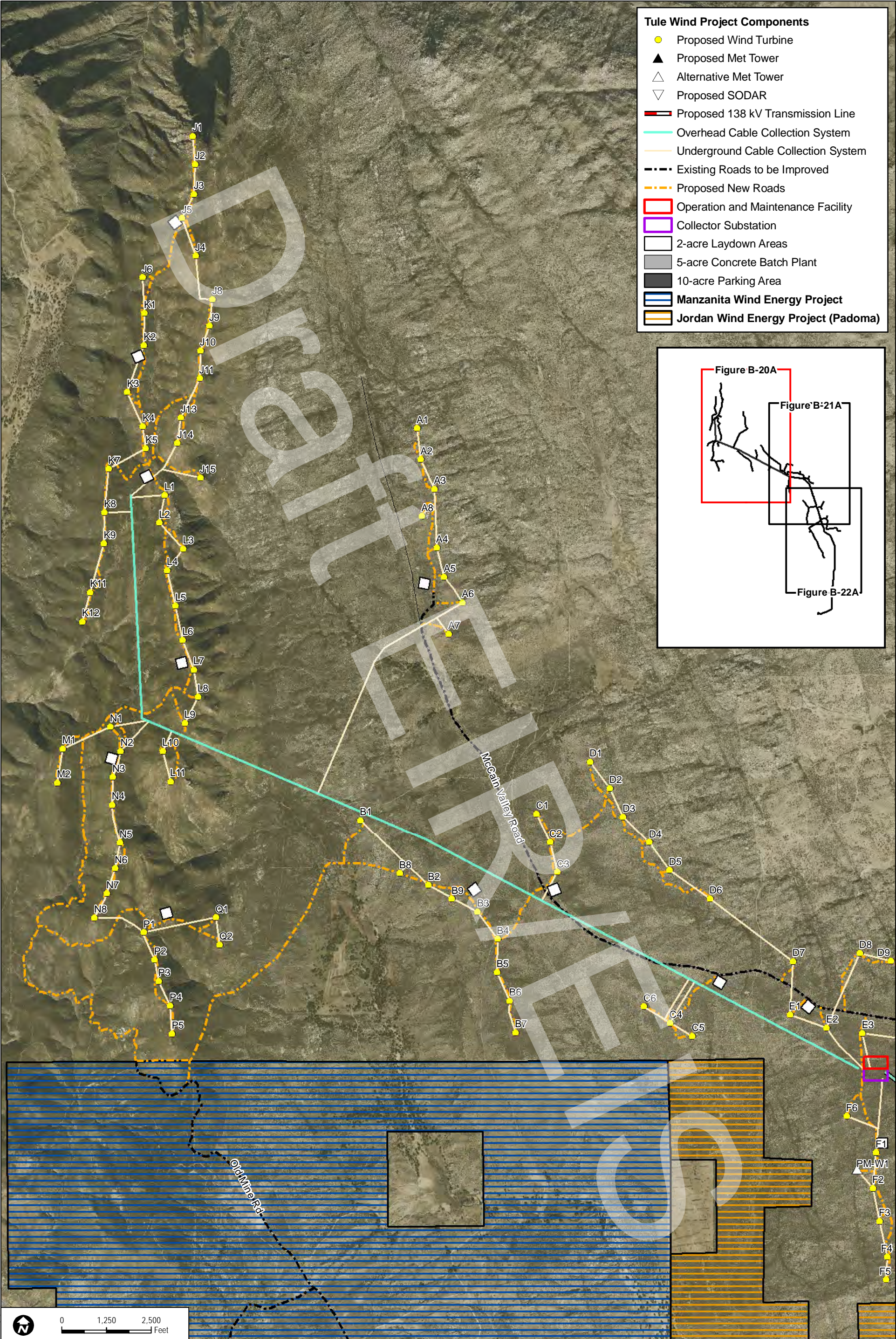

- Tule Wind Project Components**
- Proposed Wind Turbine
 - ▲ Proposed Met Tower
 - △ Alternative Met Tower
 - ▽ Proposed SODAR
 - Proposed 138 kV Transmission Line
 - Overhead Cable Collection System
 - Underground Cable Collection System
 - - - Existing Roads to be Improved
 - - - Proposed New Roads
 - Operation and Maintenance Facility
 - Collector Substation
 - 2-acre Laydown Areas
 - 5-acre Concrete Batch Plant
 - 10-acre Parking Area
 - ▨ Manzanita Wind Energy Project
 - ▨ Jordan Wind Energy Project (Padoma)

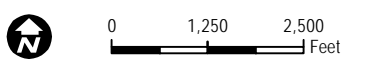
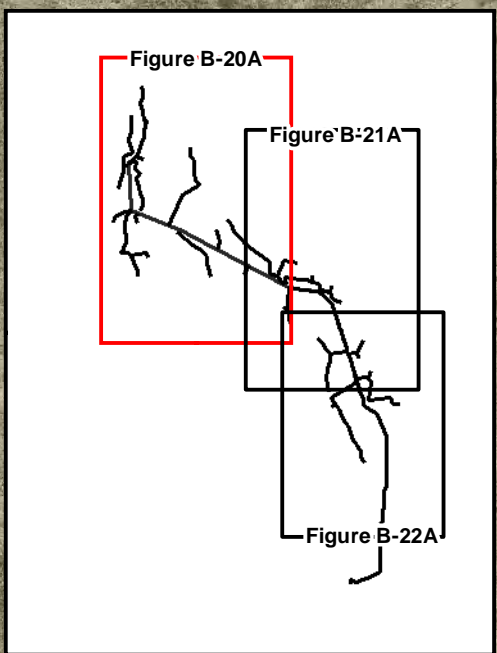

DUDEK

SOURCE: HDR 2010

**FIGURE B-20A
Tule Wind Project**

6168-01

INTENTIONALLY LEFT BLANK

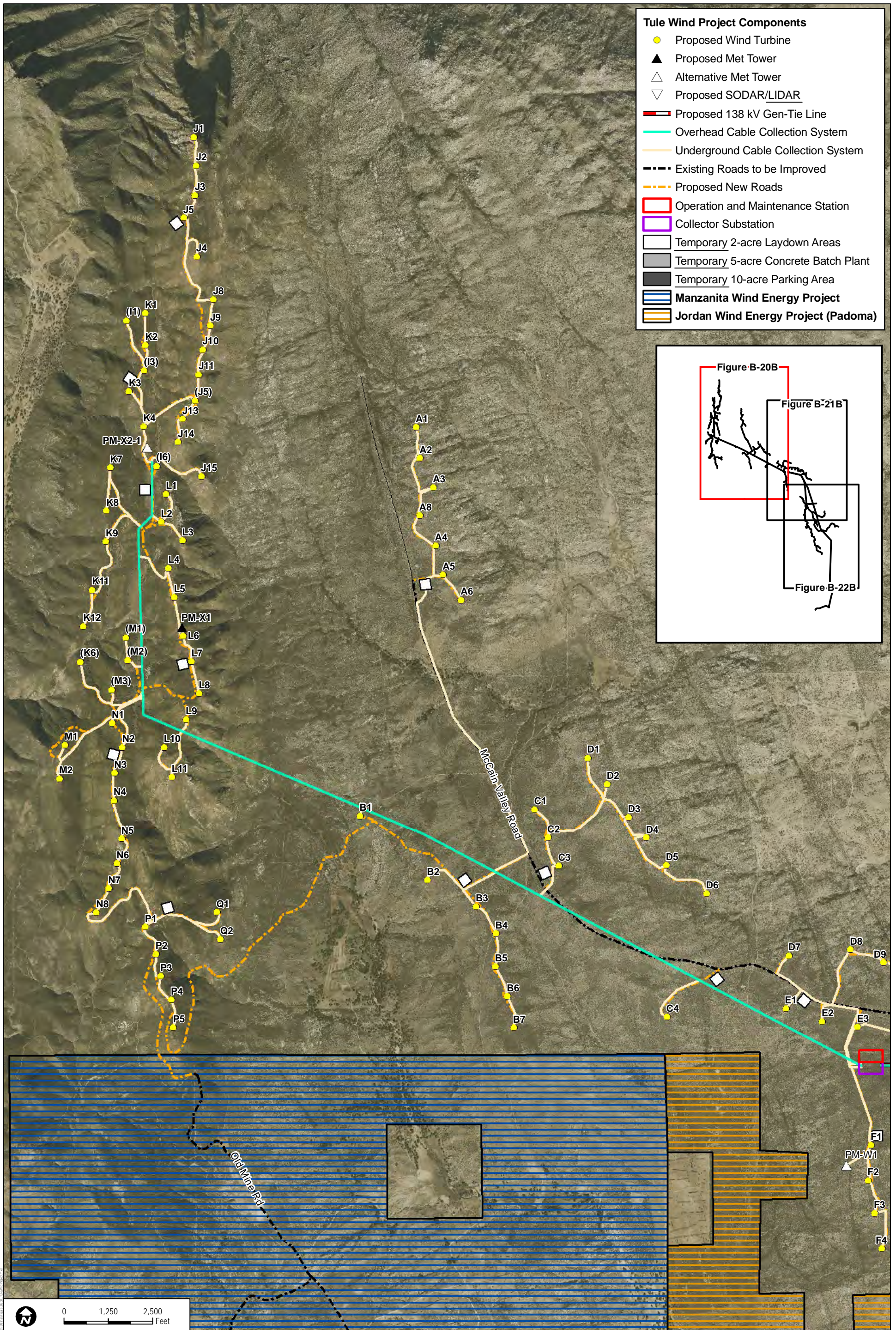

INTENTIONALLY LEFT BLANK

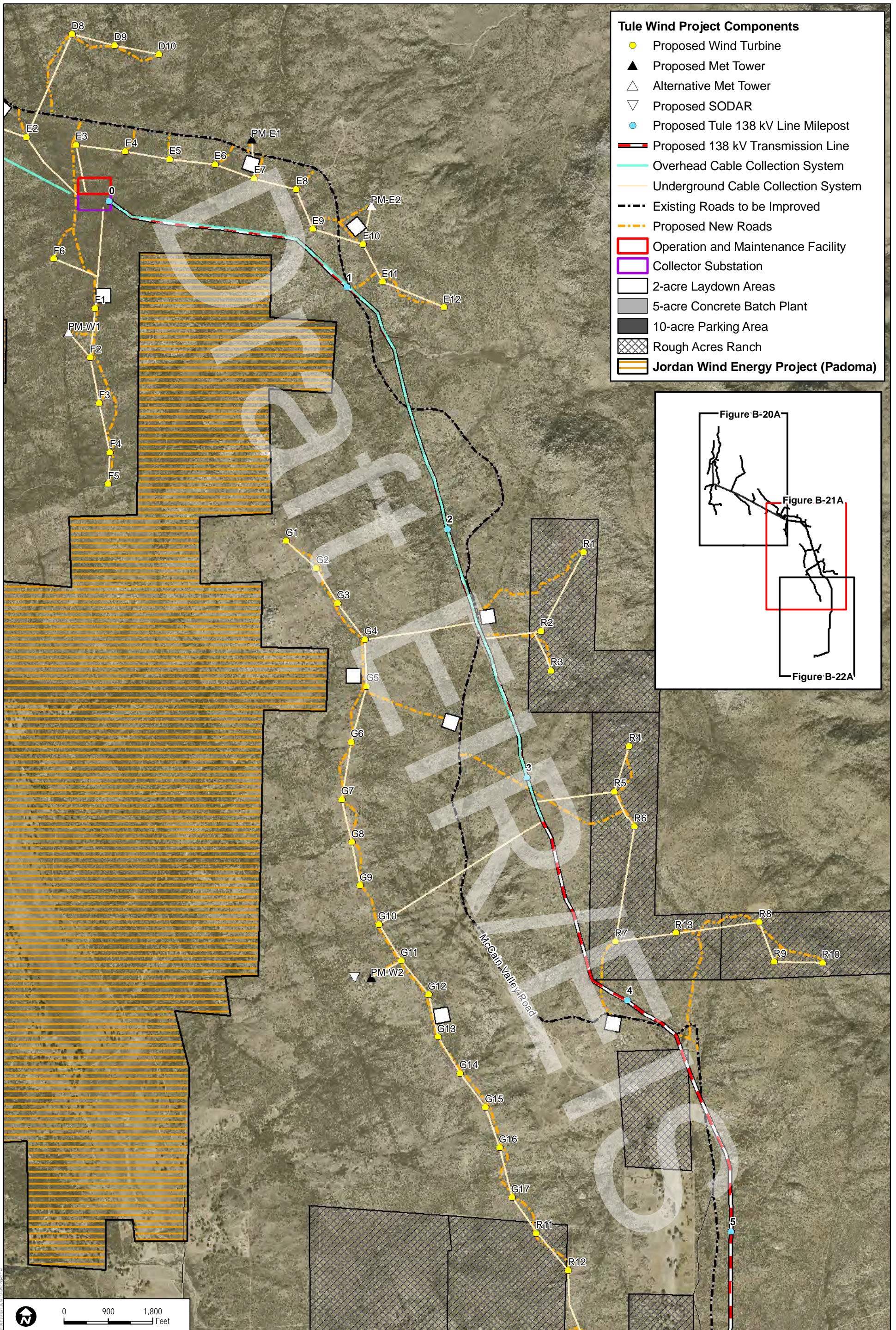

INTENTIONALLY LEFT BLANK

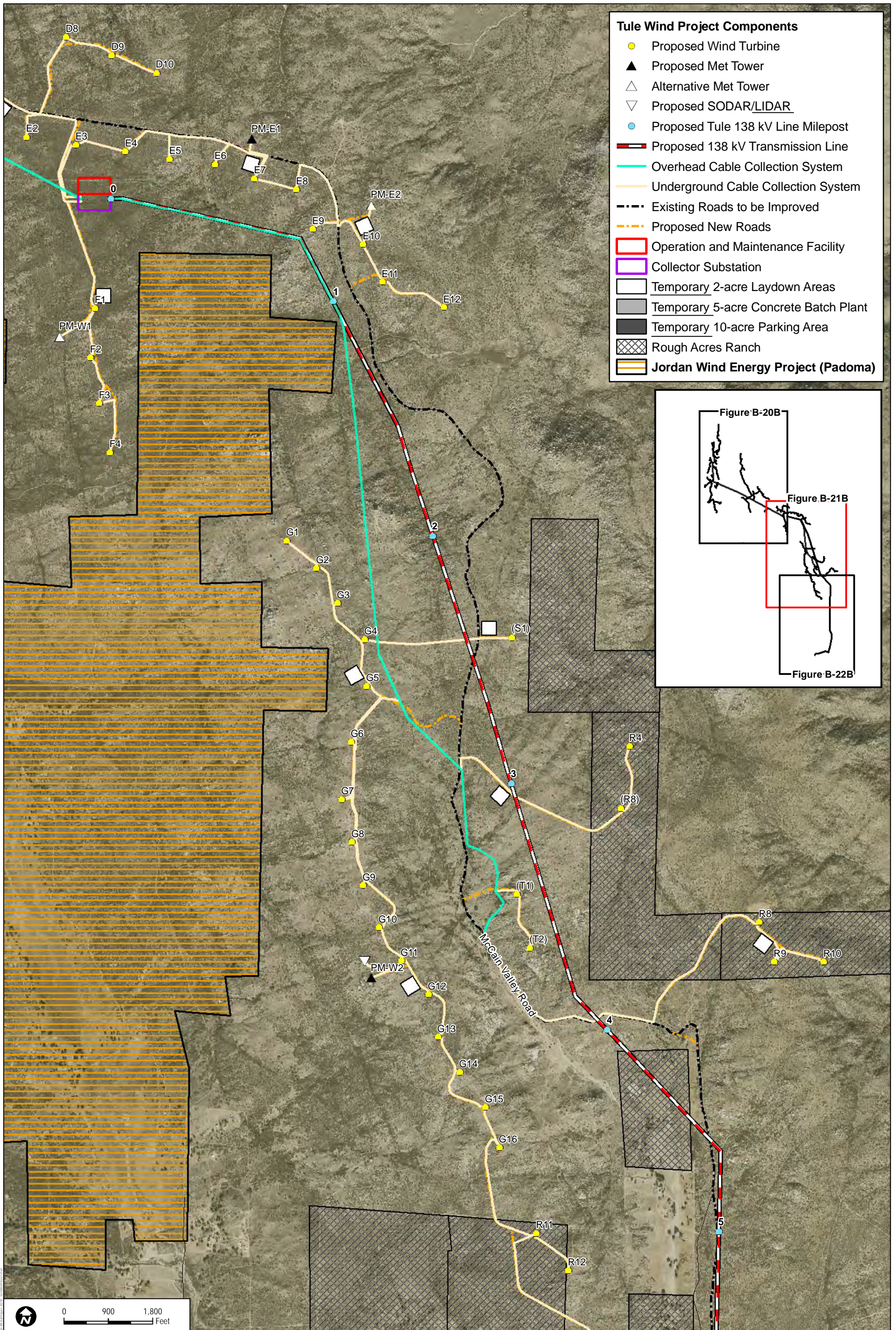

INTENTIONALLY LEFT BLANK

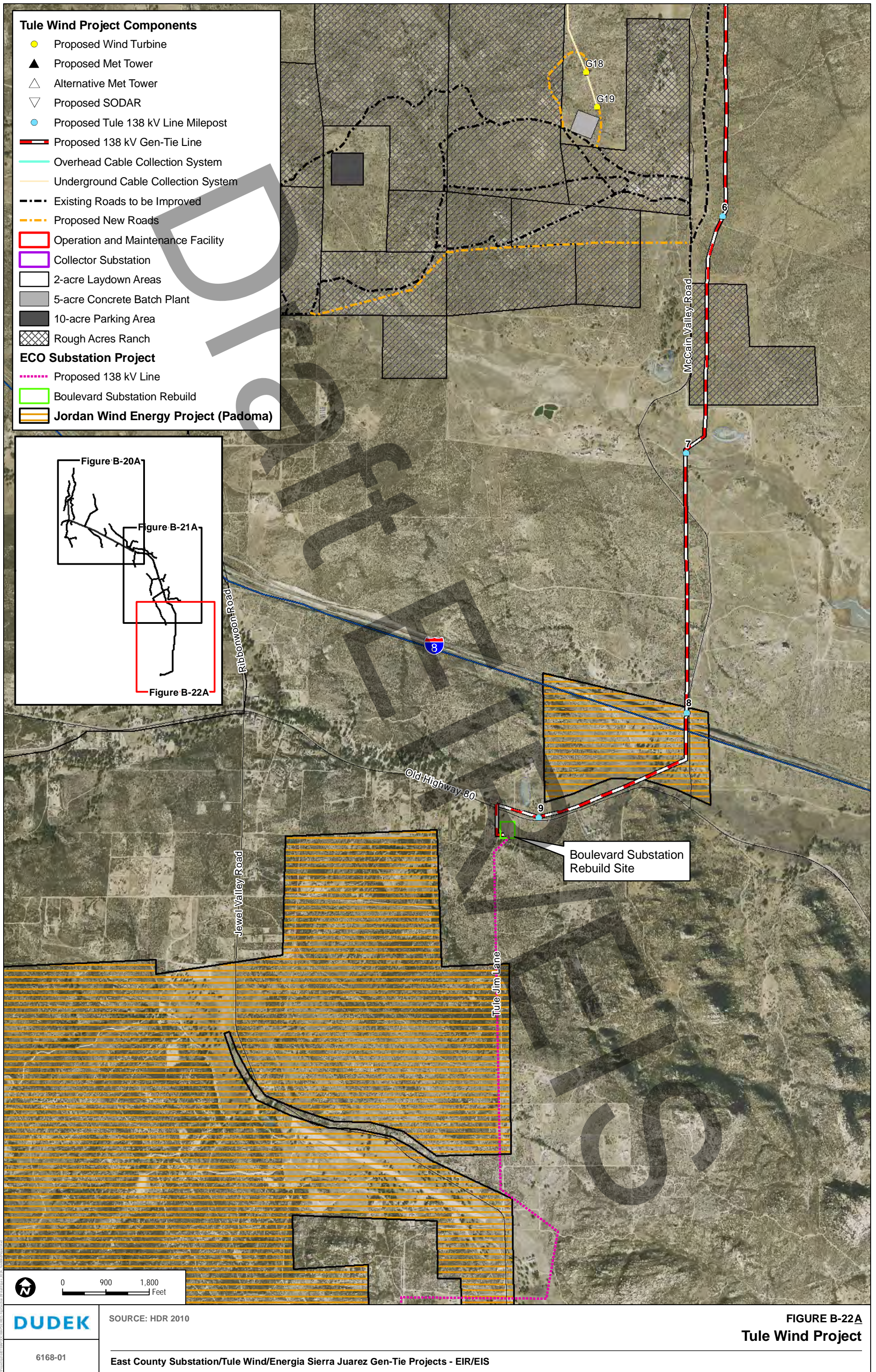
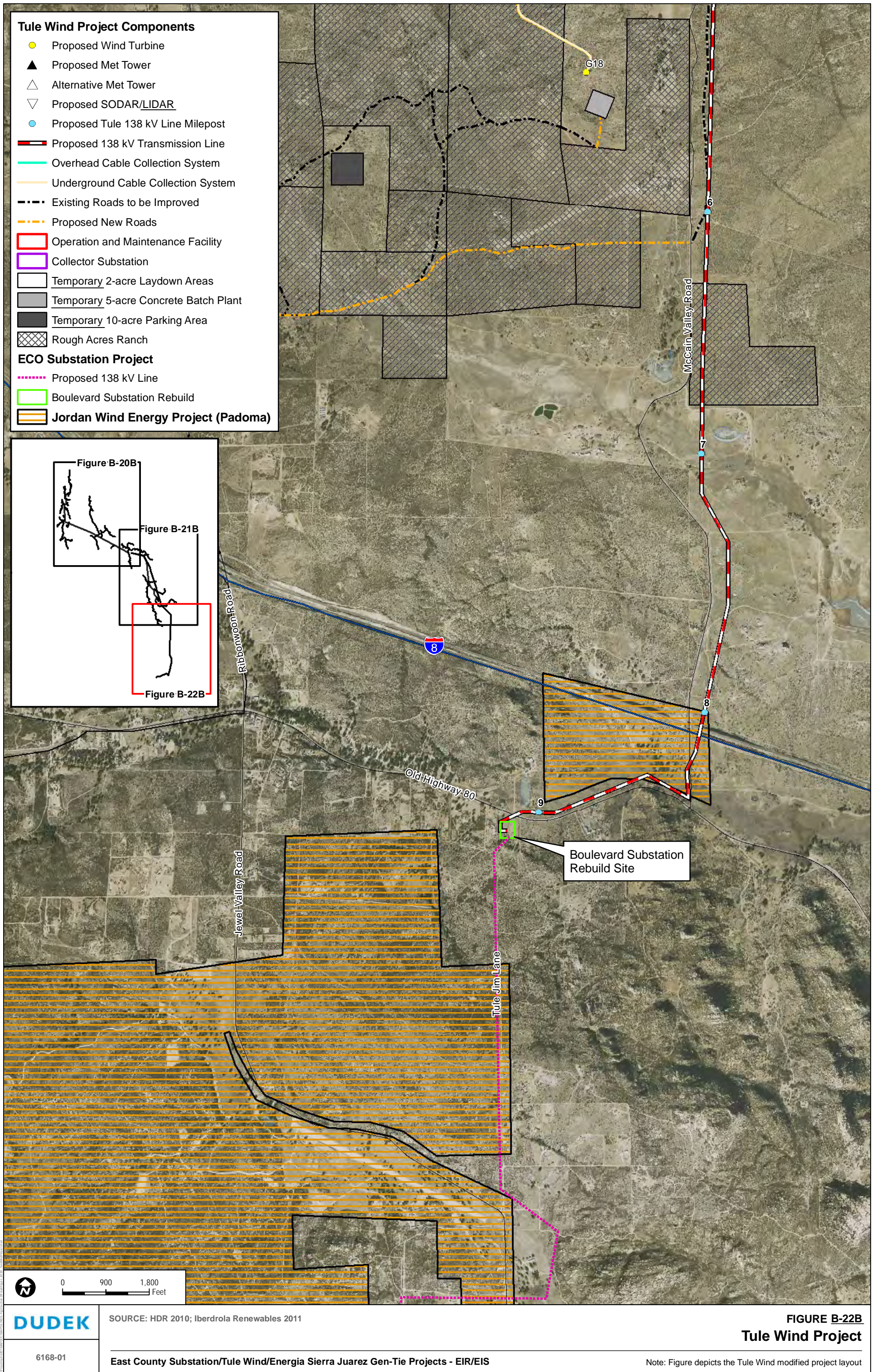

FIGURE B-22A
Tule Wind Project

INTENTIONALLY LEFT BLANK



Tule Wind Project Components

- Proposed Wind Turbine
- ▲ Proposed Met Tower
- △ Alternative Met Tower
- ▽ Proposed SODAR/LIDAR
- Proposed Tule 138 kV Line Milepost
- Proposed 138 kV Transmission Line
- Overhead Cable Collection System
- Underground Cable Collection System
- - - Existing Roads to be Improved
- - - Proposed New Roads
- Operation and Maintenance Facility
- Collector Substation
- Temporary 2-acre Laydown Areas
- Temporary 5-acre Concrete Batch Plant
- Temporary 10-acre Parking Area
- ▨ Rough Acres Ranch

ECO Substation Project

- Proposed 138 kV Line
- Boulevard Substation Rebuild

Jordan Wind Energy Project (Padoma)

- ▨ Jordan Wind Energy Project (Padoma)

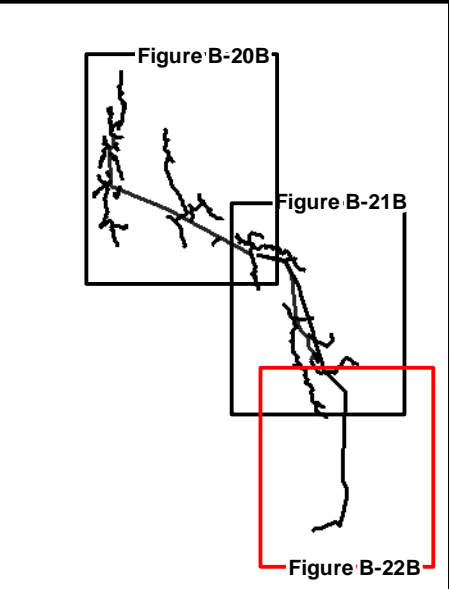

DUDEK

SOURCE: HDR 2010; Iberdrola Renewables 2011

**FIGURE B-22B
Tule Wind Project**

6168-01

East County Substation/Tule Wind/Energia Sierra Juarez Gen-Tie Projects - EIR/EIS

Note: Figure depicts the Tule Wind modified project layout

INTENTIONALLY LEFT BLANK

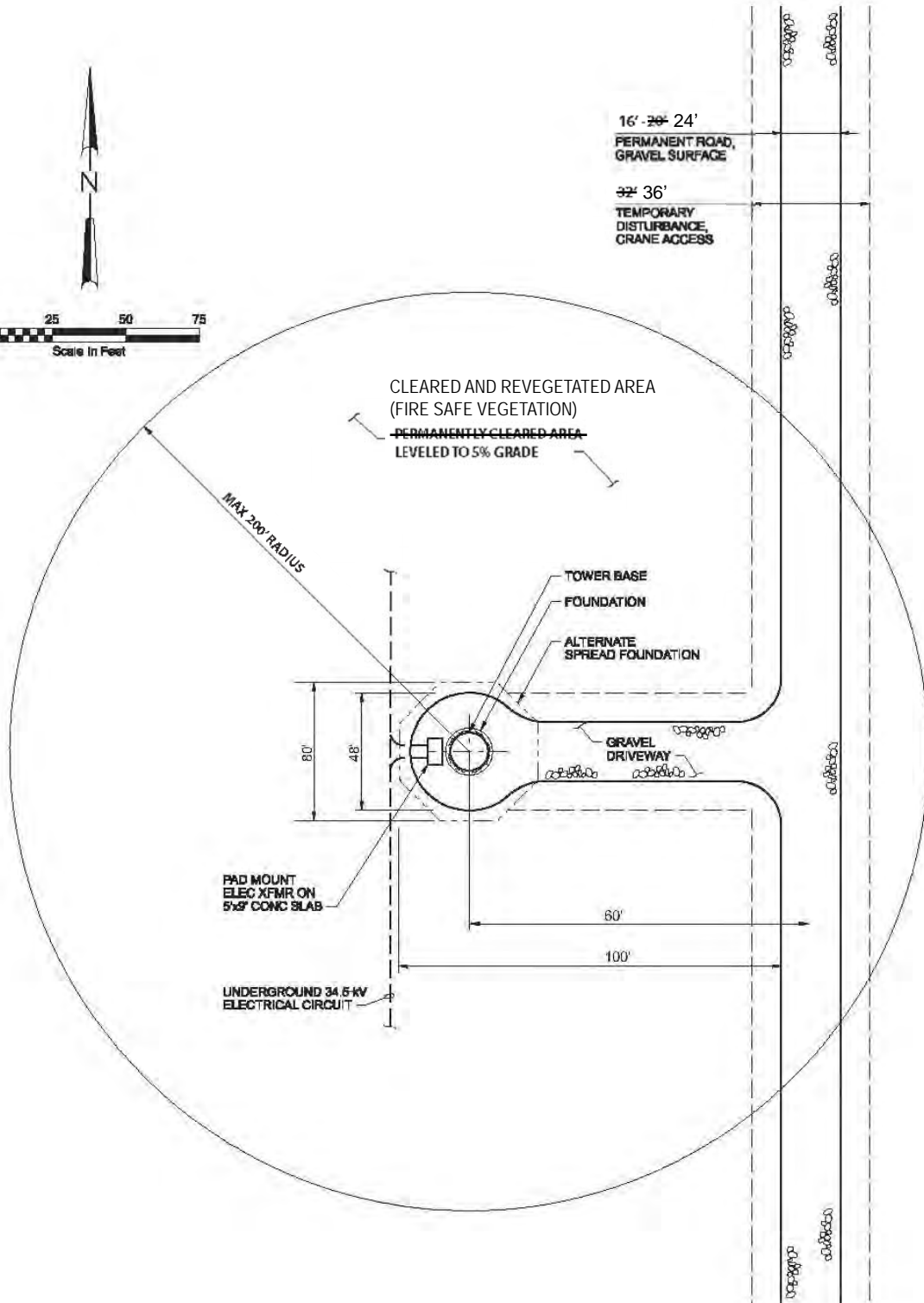
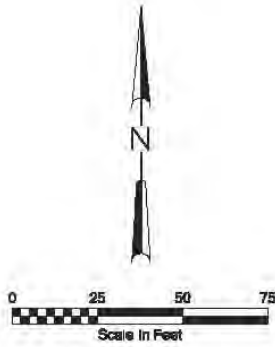

INTENTIONALLY LEFT BLANK

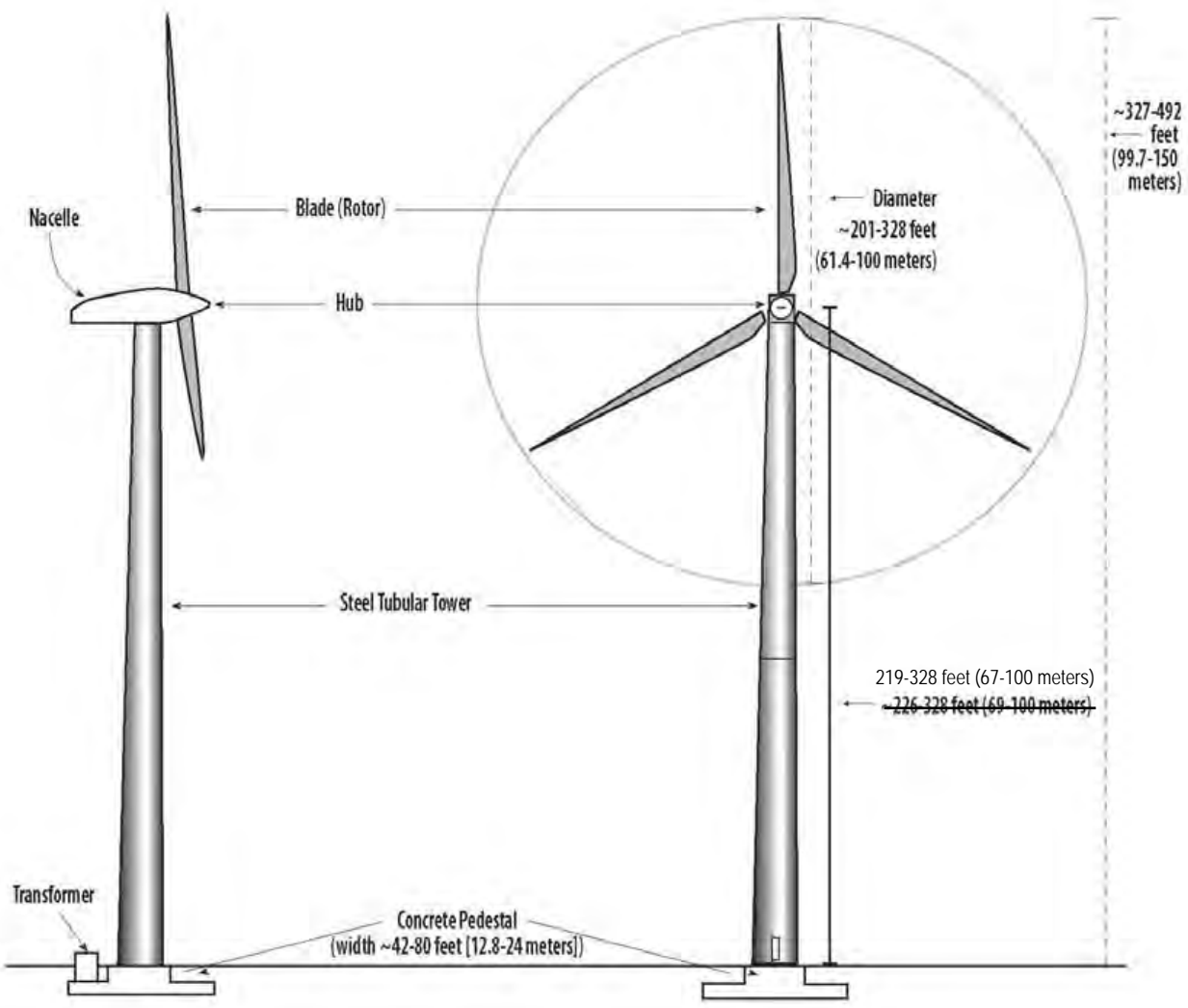

INTENTIONALLY LEFT BLANK

INTENTIONALLY LEFT BLANK

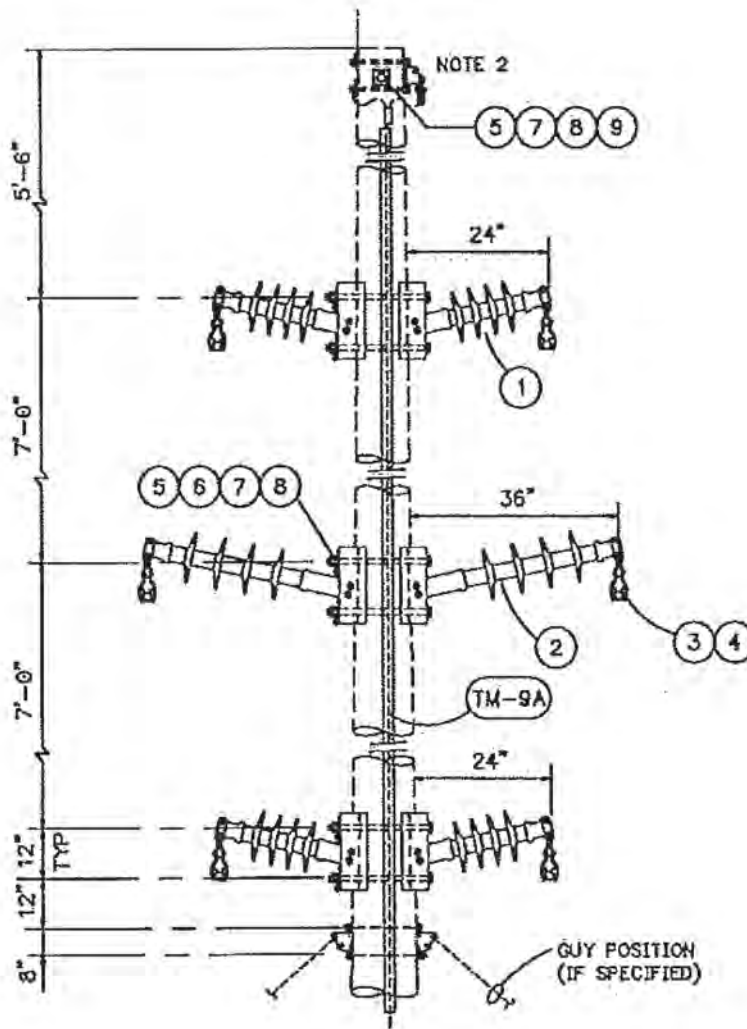

NOTES:

1. DO NOT GROUND INSULATOR BASE HARDWARE.
2. SHEILD WIRE ASSEMBLIES ARE CALLED OUT ON STAKING SHEETS.

ITEM	QTY	MATERIAL
1	4	Insulator, Polymer, Post, Horizontal, 24", 34.5-kV, MACLEAN H291024VX02
2	2	Insulator, Polymer, Post, Horizontal, 36", 34.5-kV, MACLEAN H391036VX01
3	6	Y Clevis-Eye, 25k lbs, PREFORMED YC-5209
4	6	Clamp, suspension, Armor Grip, 1272 AAC "NARCISSUS", PREFORMED AGS-5138
5	7	Bolt, machine, 3/8", by required length
6	6	Washer, round 2"x 1/4", 1 3/8" dia. hole
7	7	Locknut, 3/8", MF type
8	7	Washer, spring, 3/8"
9	2	Washer, curved, 4" Sq. x 3/8", 1 3/8" Dia. Hole
TM-9A	1	Pole Ground, Ground Rod

INTENTIONALLY LEFT BLANK

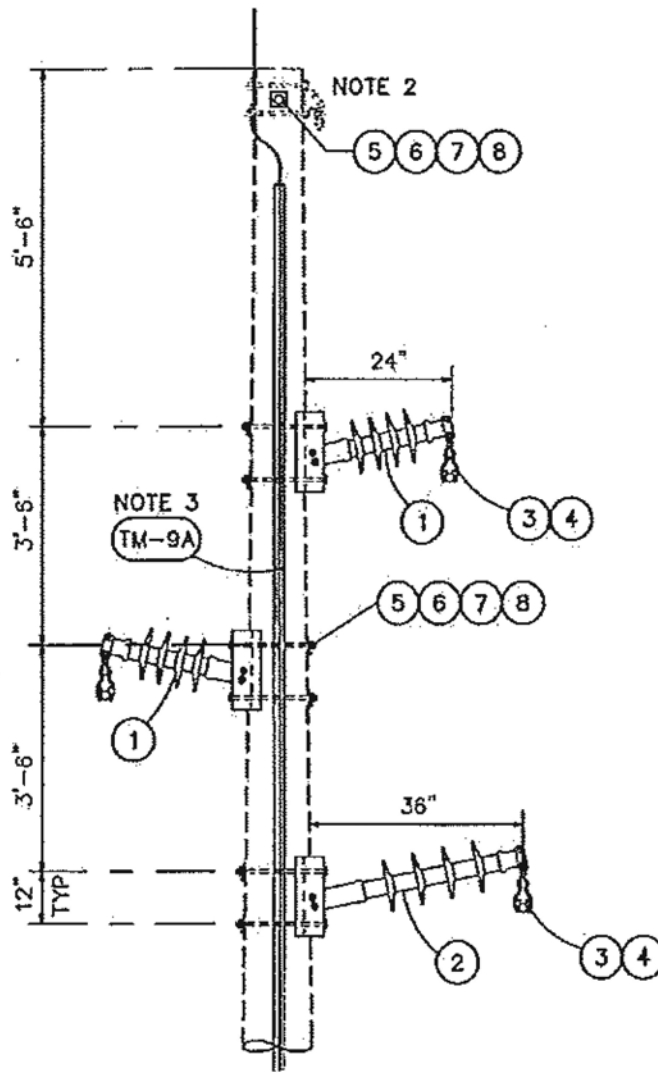

NOTES:

1. DO NOT GROUND INSULATOR BASE HARDWARE.
2. SHIELD WIRE ASSEMBLIES ARE CALLED OUT SEPARATELY ON STAKING SHEETS.
3. SPECIAL MOLDING REQUIRED FOR RAPTOR-SAFE DESIGN.

ITEM	QTY	MATERIAL
1	2	Insulator, polymer, post, horizontal, 24", 34.5-kV, 2½" rod, MACLEAN H291024VX02 OR LAPP CL2-024-210-29-A
2	1	Insulator, polymer, post, horizontal, 36", 34.5-kV, 3" rod, MACLEAN H391036VX01
3	3	Y Clevis-Eye, 25k lbs, PREFORMED YC-5209
4	3	Clamp, suspension, Cushlon-Grip, 1272 AAC "NARCISSUS", PREFORMED CGS-1115
5	7	Bolt, machine, ¾", by required length
6	8	Washer, curved, 4" sq.x ¼", 1⅝" dia. hole
7	7	Locknut, ¾", MF type
8	7	Washer, spring, ¾"
TM-9A	1	Pole Ground, Ground Rod

Z:\Projects\616801\WAPDOCC\WAPS\EIR\EIS Figs

DUDEK

SOURCE: HDR 2010: IBERDROLA RENEWABLES 2011

FIGURE B-26b
Tule Wind Project Preliminary 34.5 kV Overhead Collector
Cable System Transmission Pole – Double Circuit

6168-01

East County Substation/Tule Wind/Energia Sierra Juarez Gen-Tie Projects EIR/EIS

Single

INTENTIONALLY LEFT BLANK

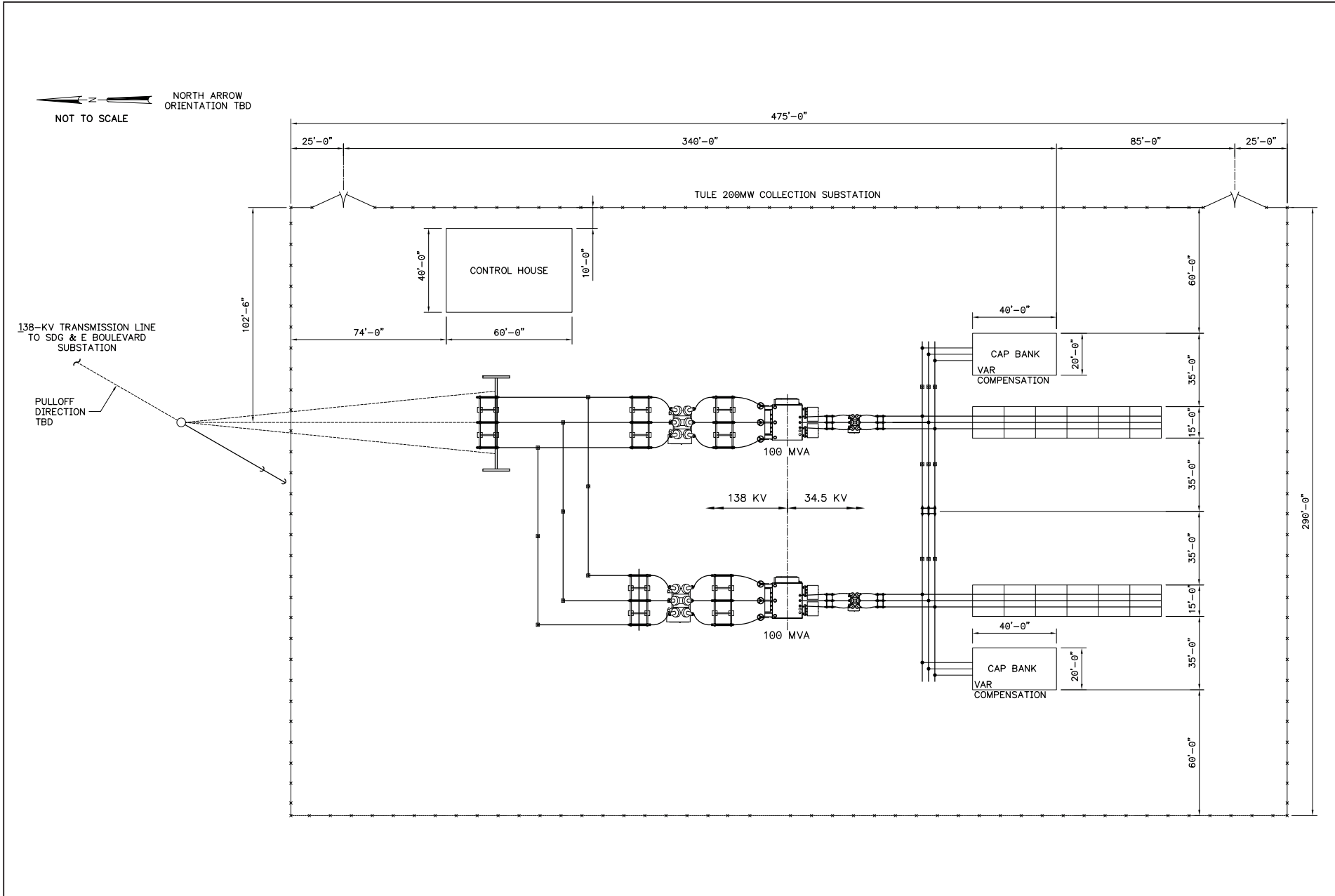
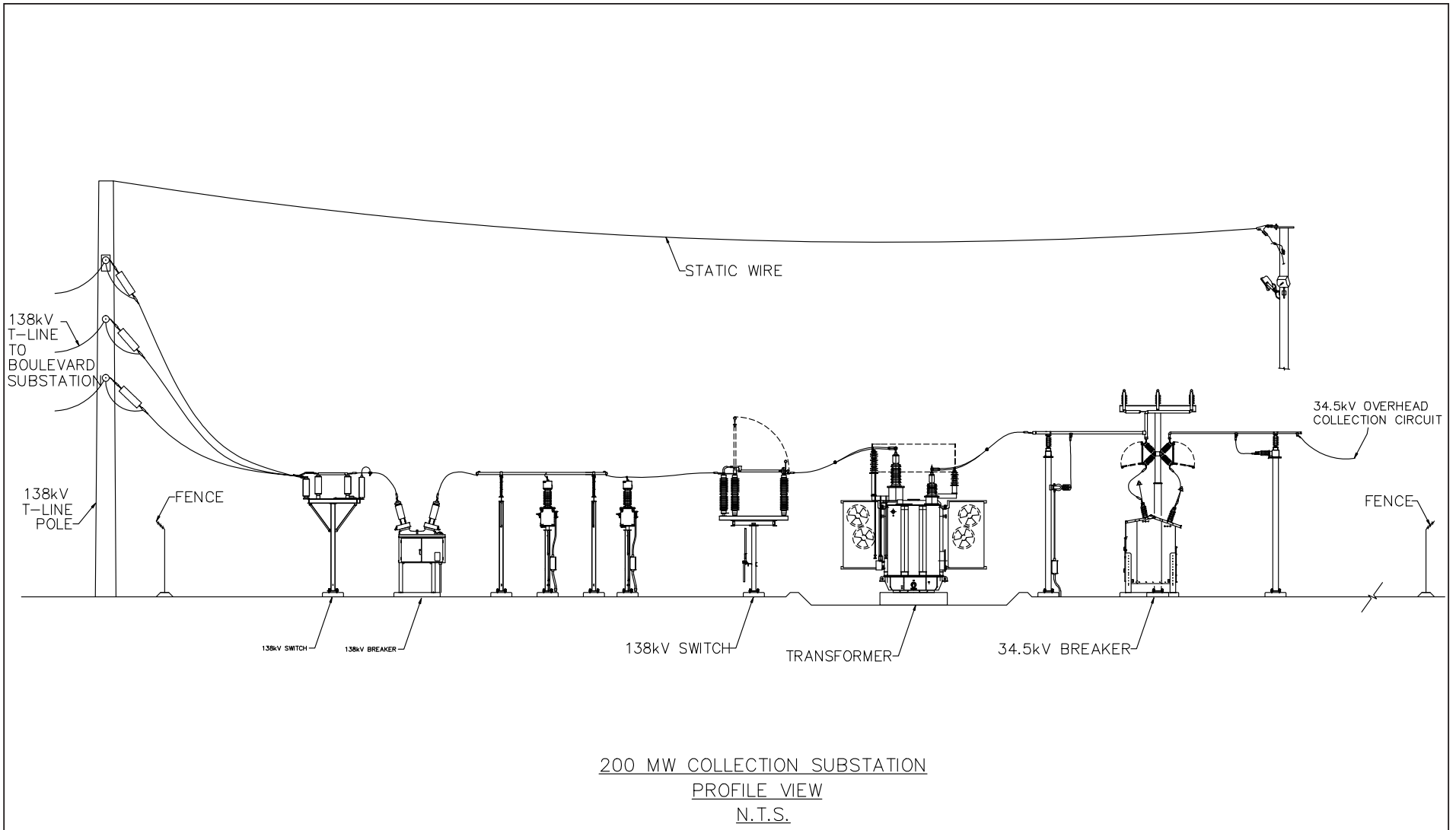

FIGURE B-27
Tule Wind Project Plan View of a Typical Collector Substation

INTENTIONALLY LEFT BLANK



Z:\Projects\616801\MAP\DOC\MAPS\EIR\EIS Figs

DUDEK

6168-01

SOURCE: HDR 2010

East County Substation/Tule Wind/Energia Sierra Juarez Gen-Tie Projects EIR/EIS

FIGURE B-28
Tule Wind Project Typical Collector Substation Profile

INTENTIONALLY LEFT BLANK

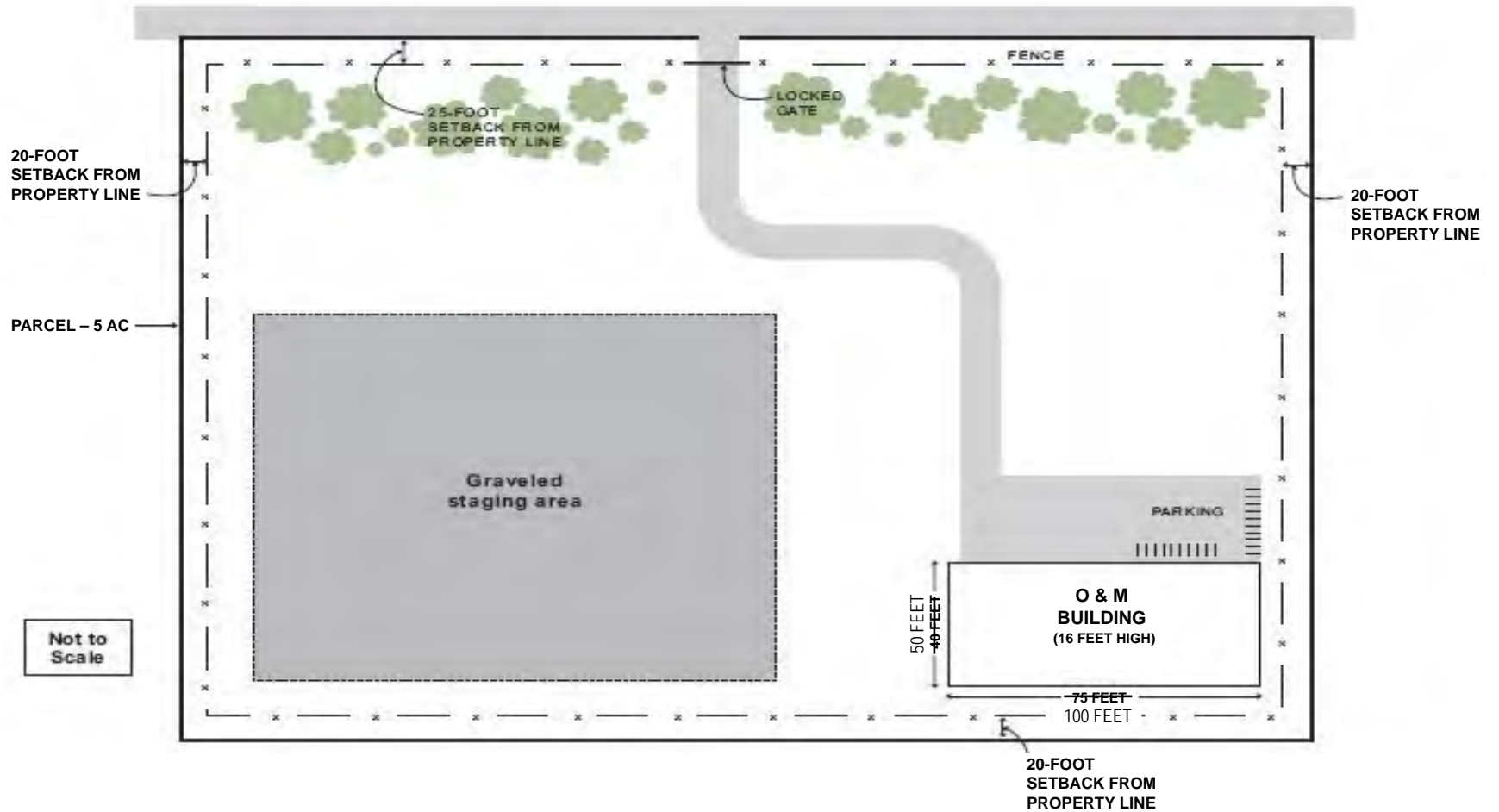

INTENTIONALLY LEFT BLANK

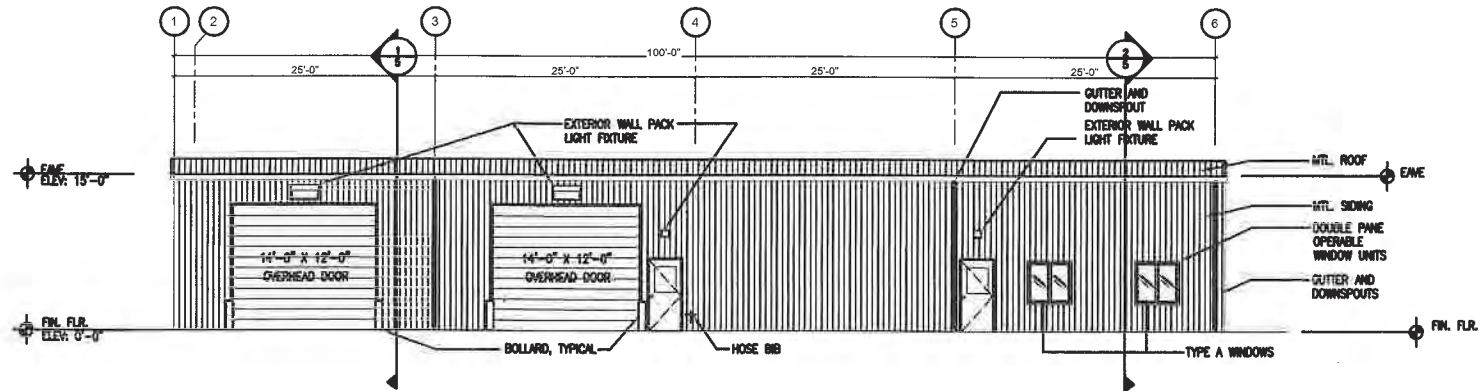

3 SOUTH ELEVATION
1/8"=1'-0"

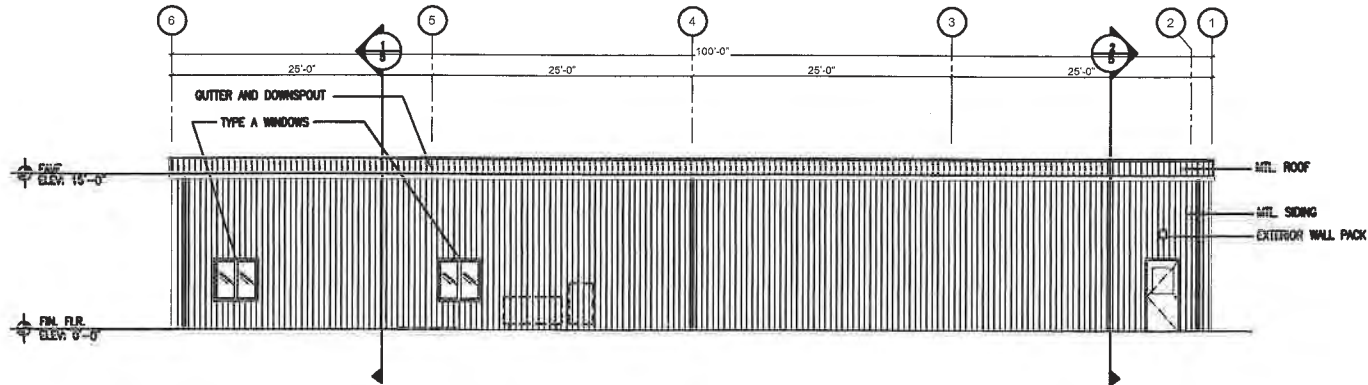

4 NORTH ELEVATION
1/8"=1'-0"

DUDEK

SOURCE: HDR 2010

Tule Wind Project Profile Views of Typical Operations and Maintenance Building

FIGURE B-30

6168-01

East County Substation/Tule Wind/Energia Sierra Juarez Gen-Tie Projects EIR/EIS

INTENTIONALLY LEFT BLANK

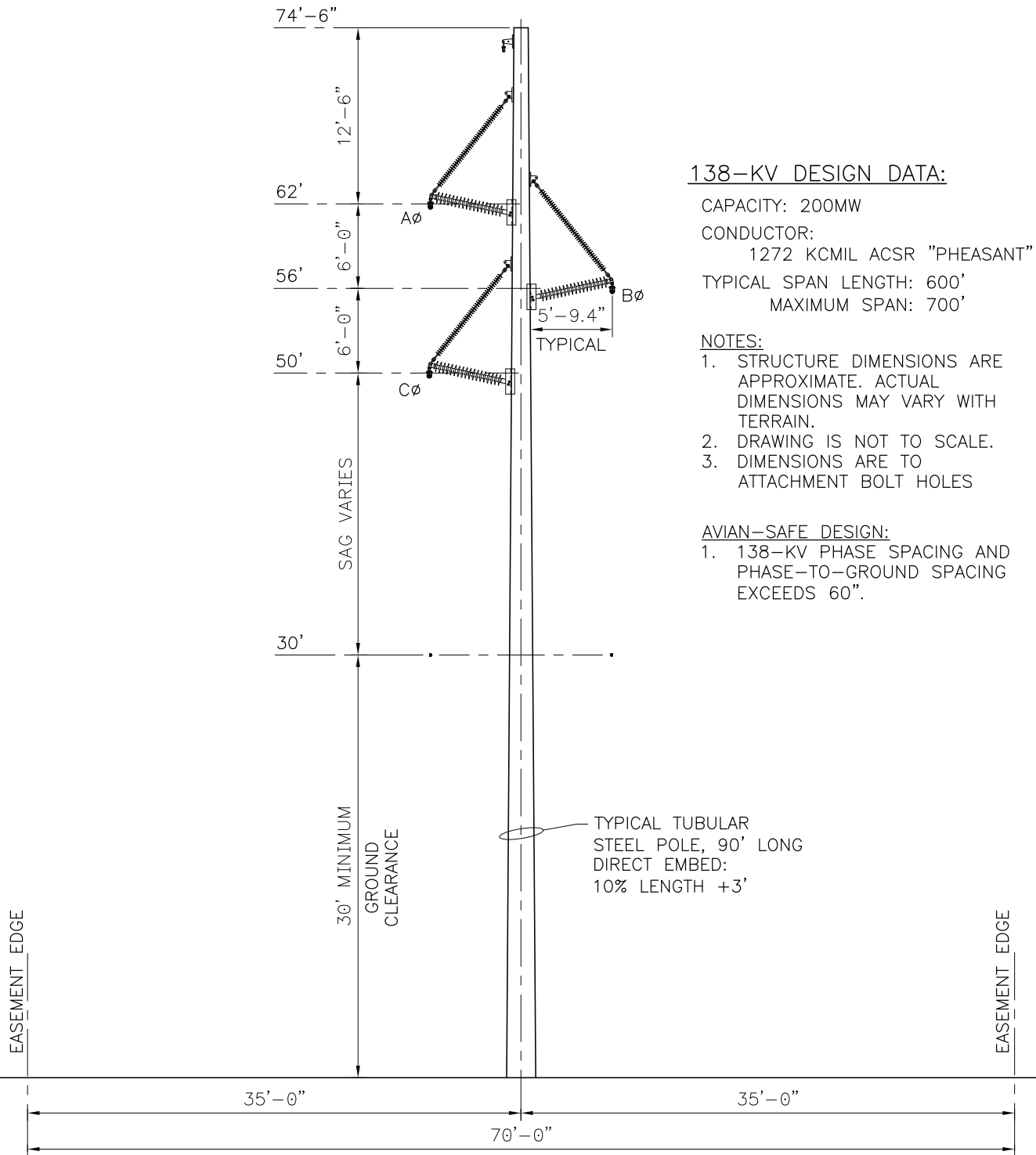

138-KV DESIGN DATA:

CAPACITY: 200MW
 CONDUCTOR:
 1272 KCMIL ACSR "PHEASANT"
 TYPICAL SPAN LENGTH: 600'
 MAXIMUM SPAN: 700'

- NOTES:**
1. STRUCTURE DIMENSIONS ARE APPROXIMATE. ACTUAL DIMENSIONS MAY VARY WITH TERRAIN.
 2. DRAWING IS NOT TO SCALE.
 3. DIMENSIONS ARE TO ATTACHMENT BOLT HOLES

- AVIAN-SAFE DESIGN:**
1. 138-KV PHASE SPACING AND PHASE-TO-GROUND SPACING EXCEEDS 60".

TYPICAL TUBULAR
 STEEL POLE, 90' LONG
 DIRECT EMBED:
 10% LENGTH + 3'

Z:\Projects\616801\MAPDOCC\MAPS\EIR\EIS Figs\Section B

INTENTIONALLY LEFT BLANK

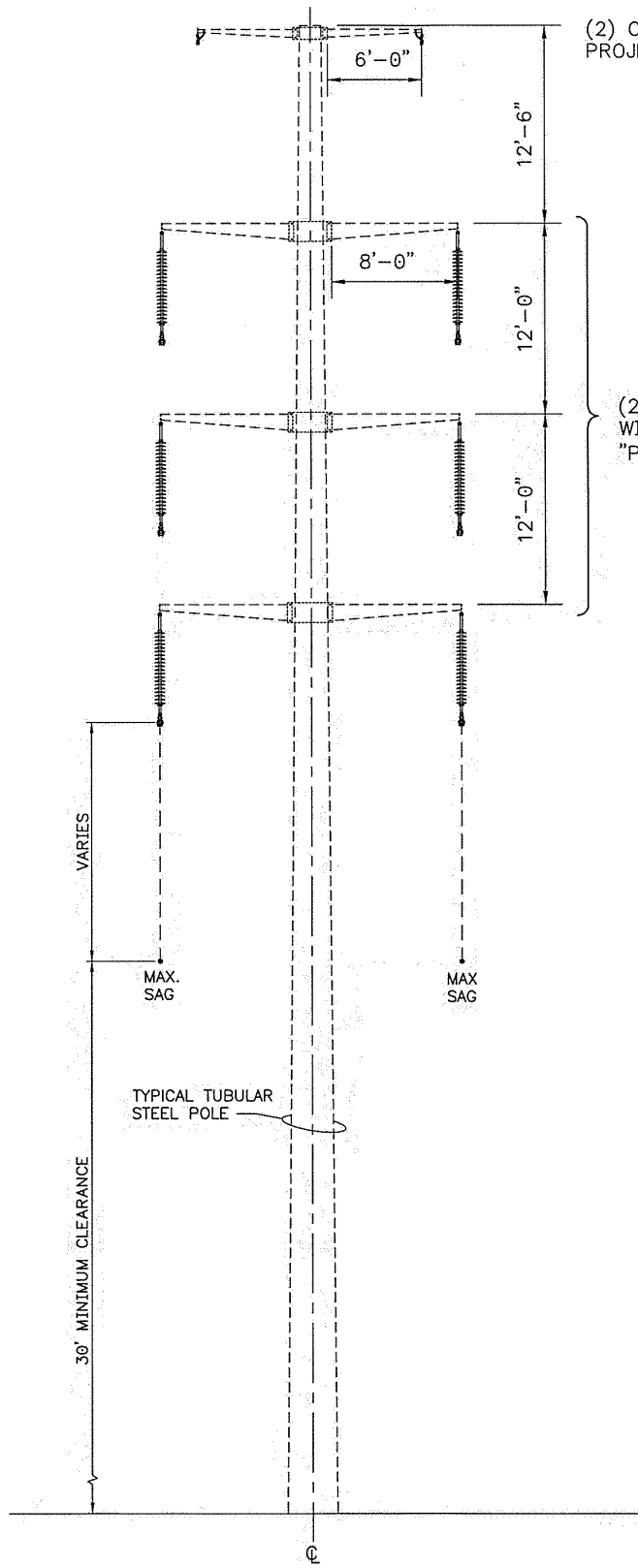

(2) OPGW CABLES FOR 138-KV PROJECTS.

(2) 138-KV CIRCUITS WITH 1272 KCMIL ACSR "PHEASANT"

PRELIMINARY CONCEPT

DESIGN ASSUMPTIONS:

- 1272 KCMIL ACSR "PHEASANT"
- RULING SPAN: 635 FT
- MAX SPAN: 700 FT

NOTES:

1. STRUCTURE DIMENSIONS ARE APPROXIMATE. ACTUAL DIMENSIONS MAY VARY.
2. DRAWING IS NOT TO EXACT SCALE

INTENTIONALLY LEFT BLANK

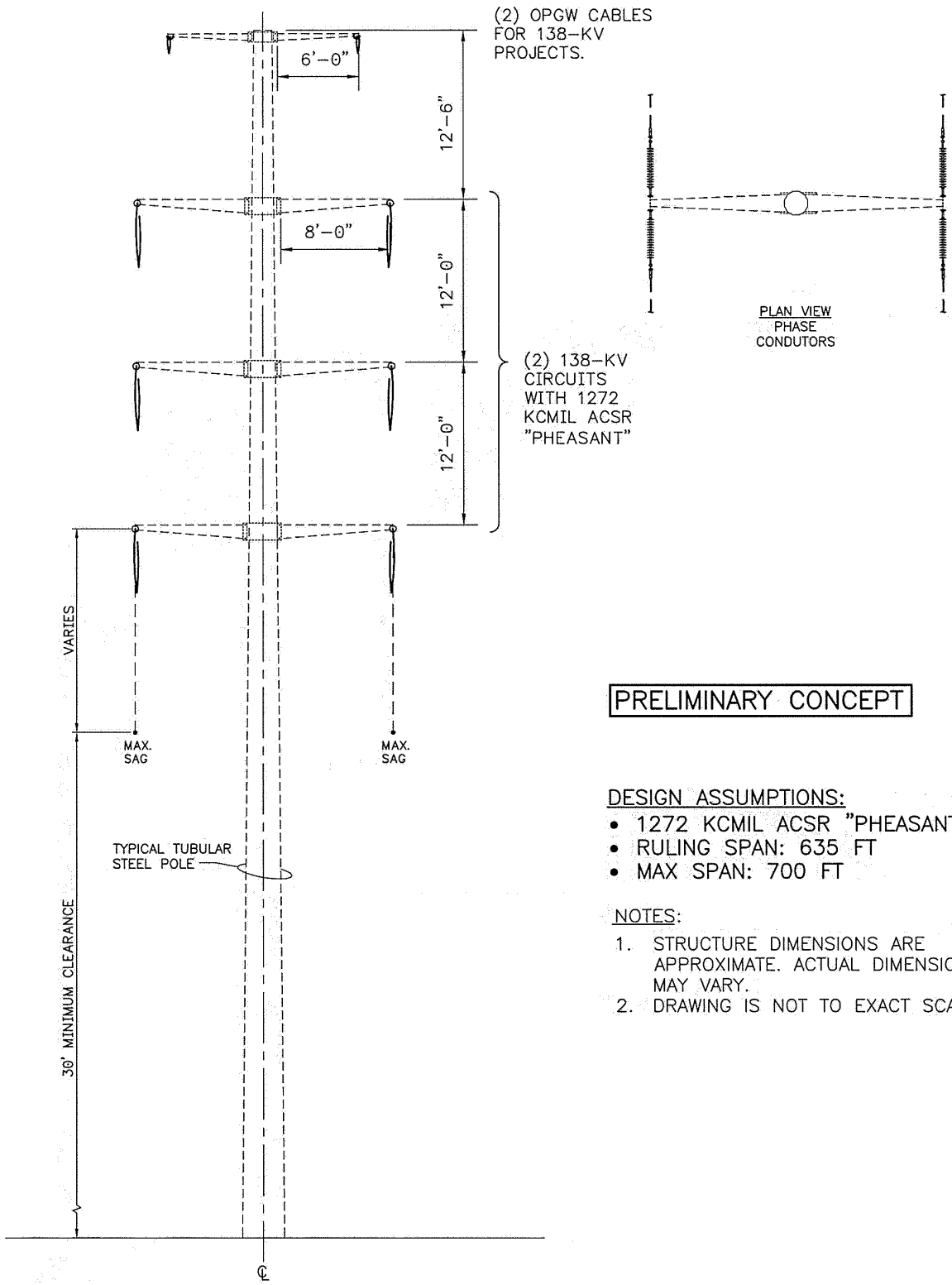

PRELIMINARY CONCEPT

- DESIGN ASSUMPTIONS:**
- 1272 KCMIL ACSR "PHEASANT"
 - RULING SPAN: 635 FT
 - MAX SPAN: 700 FT

- NOTES:**
1. STRUCTURE DIMENSIONS ARE APPROXIMATE. ACTUAL DIMENSIONS MAY VARY.
 2. DRAWING IS NOT TO EXACT SCALE

Z:\Projects\616801\MAPDOCC\MAPS\EIR\EIS Figs\Section B



SOURCE: IBERDROLA RENEWABLES 2011d

FIGURE B-31C

Tule Wind Project Typical 138 kV Double Deadend Double Circuit Pole

6168-01

East County Substation/Tule Wind/Energia Sierra Juarez Gen-Tie Projects EIR/EIS

INTENTIONALLY LEFT BLANK

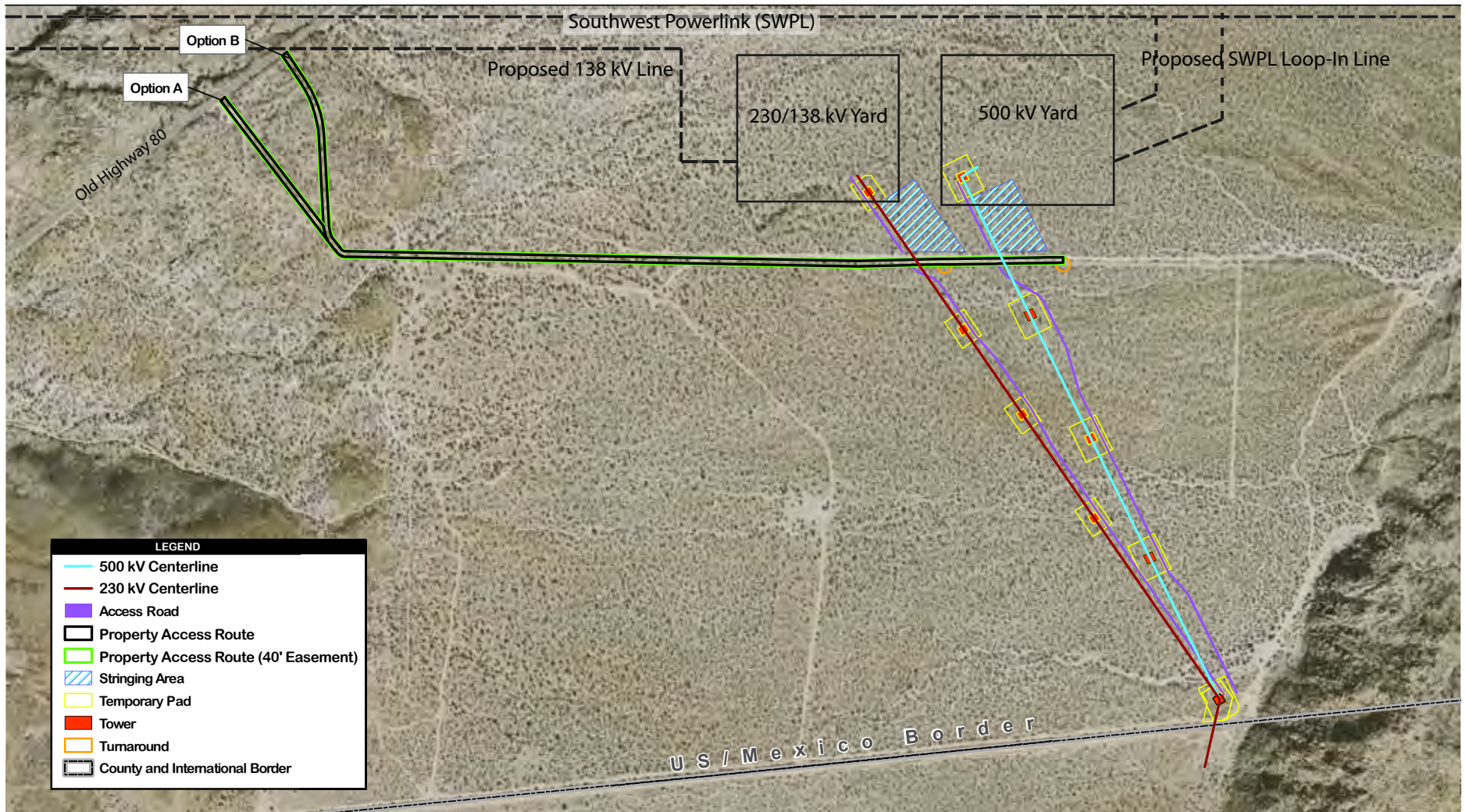

Source: DigitalGlobe 2008, Sempra Energy 2009, SANGIS 2008

500 250 0 500 Feet

Scale: 1 = 6,000; 1 inch = 500 feet

DUDEK

SOURCE: ENTRIX 2009

6168-01

East County Substation/Tule Wind/Energia Sierra Juarez Gen-Tie Projects EIR/EIS

FIGURE B-32
ESJ Gen-Tie Site Plan

INTENTIONALLY LEFT BLANK

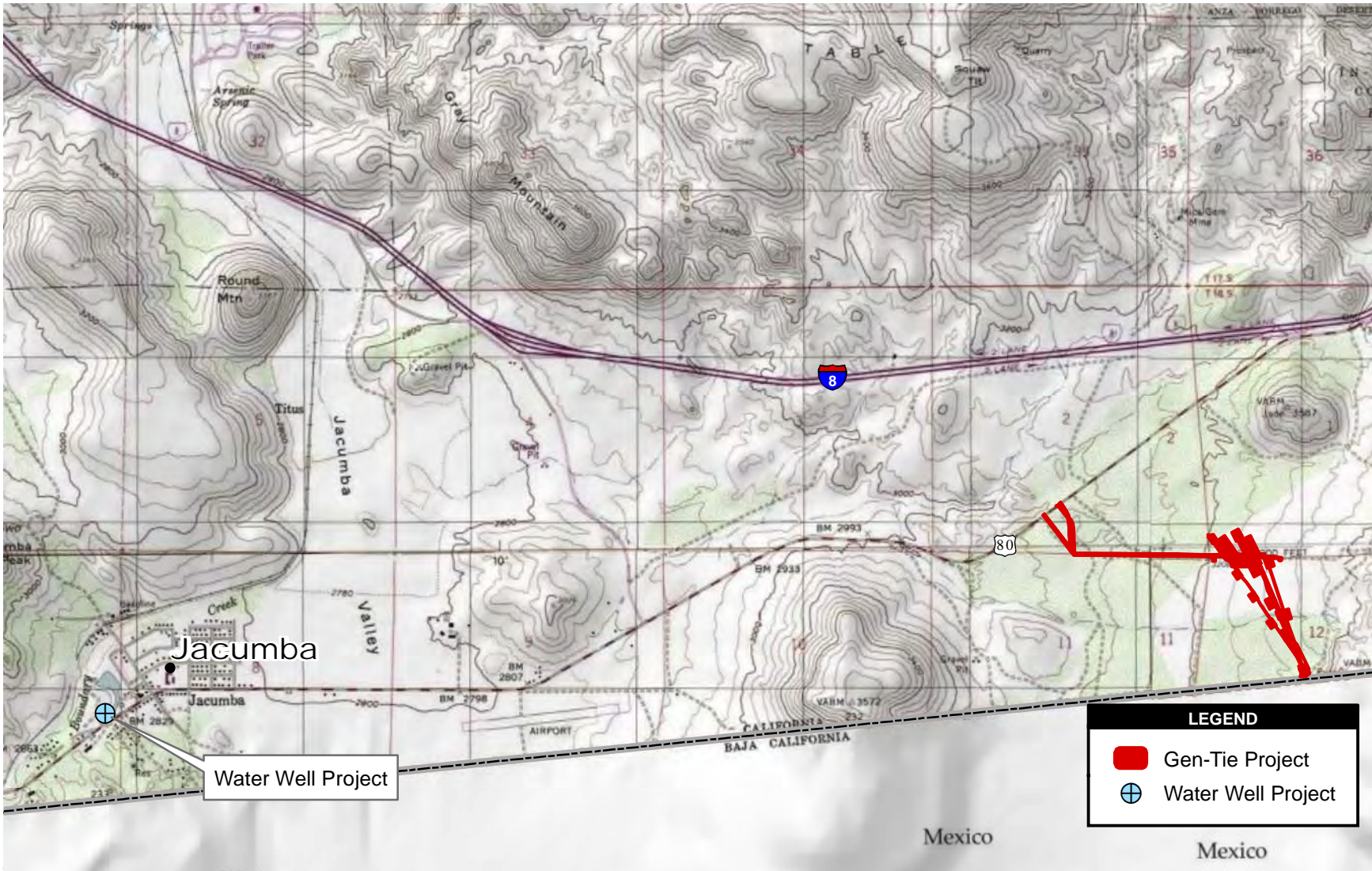

3,000 0 3,000 Feet
 Scale: 1 = 36,000; 1 inch = 3,000 feet

DUDEK

SOURCE: AECOM 2011

6168-01

East County Substation/Tule Wind/Energia Sierra Juarez Gen-Tie Projects EIR/EIS

FIGURE B-33
ESJ Gen-Tie Project and Off-Site Well Location

INTENTIONALLY LEFT BLANK