

STATE OF CALIFORNIA  
**PUBLIC UTILITIES COMMISSION**

505 VAN NESS AVENUE  
SAN FRANCISCO, CA 94102-3298

Edmund G. Brown Jr., Governor



September 18, 2015

Jack Horne  
Southern California Edison  
8631 Rush Street, General Office 4 – G10Q (Ground Floor)  
Rosemead, CA 91770

**Re: Data Request No. 5 for the Mesa 500-kV Substation Project (CPUC Proceeding A. 15-03-003)**

Mr. Horne:

Upon further review of Southern California Edison's Proponent's Environmental Assessment (PEA), the Energy Division requests the information contained in Attachment 1 to this letter. In an effort to expedite scheduling per SCE's request, we request that the responses to this item be provided to us within 14 days.

The Energy Division reserves the right to request additional information at any point in the process. Questions relating to the Mesa 500-kV Substation Project should be directed to me at (415) 703-1966 or [lisa.orsaba@cpuc.ca.gov](mailto:lisa.orsaba@cpuc.ca.gov).

Sincerely,

*MJ Orsaba*

Lisa Orsaba,  
California Public Utilities Commission  
Energy Division

CC: Claire Hodgkins, Ecology and Environment, Inc.  
Kristi Black, Ecology and Environment, Inc.

Attachment 1: Data Request #5

Attachment 2: Study of Mesa 500-kV Substation with One Transformer

Attachment 3: Study of No Project with Outages (N-1-1 outage of 500-kV transmission lines)

# Attachment 1

Item #	Reference/ Page #	Title	Request
DR#5 Q.1	N/A	<b>Alternatives: Load Shedding in Mission Viejo</b>	<p>CAISO transmission planning standards do not allow for non-consequential load shedding in high-density urban areas. SCE stated in its response to Data Request #2, Q.4-01(B) that load shedding in other areas (i.e. areas that are not identified as high-density urban areas) “would not be effective.” Provide substantiation to support SCE’s conclusion:</p> <ul style="list-style-type: none"> <li>A. State whether load shedding in Mission Viejo could be used after the first outage in either studied N-1-1 contingency (i.e., outage of the Eco-Miguel 500-kV Transmission Line followed by an outage of the Ocotillo-Suncrest 500-kV Transmission Line, or outage of the Lewis–Serrano No. 1 230-kV Transmission Line followed by an outage of the Serrano–Villa Park No. 1 230-kV Transmission Line) to meet reliability standards.</li> <li>B. Provide evidence, such as a power flow study or other data, that substantiates SCE’s answer to A.</li> </ul>
DR#5 Q.2	N/A	<b>Alternatives: Reduced substation alternative</b>	<p>A study, using SCE-provided data, demonstrates that one 500-kV transformer bank at a 500-kV Mesa Substation would address low voltage in the Serrano corridor following an outage of the Eco-Miguel 500-kV Transmission Line followed by an outage of the Ocotillo-Suncrest 500-kV Transmission Line (“500-kV N-1-1 contingency”). Refer to the study in Attachment 2. Provide the following information about a reduced substation alternative that would consist of one 500-kV transformer bank:</p> <ul style="list-style-type: none"> <li>A. State whether SCE concurs that one 500-kV transformer bank would address overloading on the Serrano Corridor following the 500-kV N-1-1 contingency. If not, explain why not.</li> <li>B. Would it be feasible to construct a 500-kV substation with one transformer bank west of the existing 230-kV substation? Explain why or</li> </ul>

Item #	Reference/ Page #	Title	Request
			<p>why not.</p> <p>C. Would it be feasible to loop in the Mira Loma–Vincent 500-kV transmission line and connect the new, one-transformer, 500-kV substation to the existing 220-kV substation in this configuration? Explain why or why not.</p>
DR#5 Q.3	PEA, pg. 2-4; N/A	<b>Alternatives/ Objectives; voltage collapse following the 500-kV N-1-1 contingency</b>	<p>Page 2-4 of the PEA states that the N-1-1 contingency involving an outage of the Eco-Miguel 500-kV Transmission Line followed by an outage of the Ocotillo-Suncrest 500-kV Transmission Line (“500-kV N-1-1 contingency”) would result in voltage collapse. In response to Data Request #2, Follow Up 01 Q.04-01(C), SCE states that this 500-kV N-1-1 contingency would result in “voltage issues . . . located at substations spread throughout the Western LA Basin.” In response to Data Request #3, in SCE’s Attachment A, SCE states that the 500-kV N-1-1 contingency would cause “low voltages [to] occur.”</p> <p>However, in a study of the 500-kV N-1-1 contingency with SCE-provided data, the CPUC was unable to substantiate SCE’s claim of a voltage collapse or voltage issues located at multiple substations. Only the Serrano Substation, with a voltage of 0.897 pu, was noted as experiencing a voltage below that allowed by CAISO Transmission Planning Standards, Table 1, in the event of a 500-kV N-1-1 contingency. Refer to the study in Attachment 3.</p> <p>Provide the following information about the voltage collapse and/or voltage issues identified by SCE following the 500-kV N-1-1 contingency:</p> <p>A. Substantiate the claim that the 500-kV N-1-1 contingency would result in voltage collapse. Do not refer to the CAISO 2013–14 Transmission Plan in the answer to this question. The CPUC has reviewed and is aware of the CAISO plan and requests information other than, or in addition to, the information provided in that plan.</p>

Item #	Reference/ Page #	Title	Request
			<p>B. Substantiate the claim that the 500-kV N-1-1 contingency would result in “voltage issues . . . located at substations spread throughout the Western LA Basin.” Specify which substation(s) would experience low voltage. Do not refer to the CAISO 2013–14 Transmission Plan in the answer to this question. The CPUC has reviewed and is aware of the CAISO plan and requests information other than, or in addition to, the information provided in that plan.</p> <p>C. State whether tap changing at Serrano Substation would address the low voltage issue at the Serrano Substation.</p>
DR#5 Q.4	N/A	<b>Alternatives; Gas-insulated substation</b>	<p>A gas-insulated substation would require a smaller footprint. Provide the following information:</p> <p>A. Would it be feasible to construct a 500-kV gas insulated substation west of the existing 230-kV substation? Explain why or why not.</p> <p>B. Would it be feasible to loop in the Mira Loma–Vincent 500-kV transmission line and connect the new 500-kV substation to the existing 220-kV substation in this configuration? Explain why or why not.</p>
DR#5 Q.5	N/A	<b>Alternatives; thermal overload on the Serrano-Villa Park No. 2 230-kV transmission line</b>	<p>One of SCE’s stated purposes of the proposed project is to address a thermal overload on the Serrano–Villa Park No. 2 230-kV Transmission Line caused by an N-1-1 outage of the Lewis–Serrano No. 1 230-kV Transmission Line followed by an outage of the Serrano–Villa Park No. 1 230-kV Transmission Line (“230-kV N-1-1 contingency”). However, the CPUC has insufficient power flow data to substantiate this claim.</p> <p>Further, the CAISO 2013–14 Transmission Plan states that the Mesa Substation Project would address the N-1-1 scenario involving an outage of the Eco-Miguel 500-kV Transmission Line followed by an outage of the Ocotillo–Suncrest 500-kV Transmission Line, but the Transmission Plan does not state that the Mesa Substation Project</p>

Item #	Reference/ Page #	Title	Request
			<p>would address a 230-kV N-1-1 contingency.</p> <ul style="list-style-type: none"> <li>A. State whether the proposed project is meant to address overloads on the Serrano – Villa Park No. 2 230-kV Transmission Line following the 230-kV N-1-1 contingency.</li> <li>B. If the proposed project is meant to address the 230-kV N-1-1 contingency, provide a rationale for why the CAISO did not make a statement to this effect in the Transmission Plan.</li> <li>C. If the proposed project is meant to address the 230-kV N-1-1 contingency, provide evidence, such as a power flow study or data, that substantiates that the project would address overloads on the Serrano – Villa Park No. 2 230-kV Transmission Line following the 230-kV N-1-1 contingency.</li> </ul>
DR#5 Q.6	N/A	<b>No Project Alternative</b>	<p>Provide the following information:</p> <ul style="list-style-type: none"> <li>A. Frequency and duration for outages on the Eco-Miguel 500-kV Transmission Line</li> <li>B. Frequency and duration for outages on the Ocotillo-Suncrest 500-kV Transmission Line</li> <li>C. Frequency and duration of outages on the Lewis–Serrano No. 1 230-kV Transmission Line</li> <li>D. Frequency and duration of outages on the Serrano–Villa Park No. 1 230-kV Transmission Line</li> <li>E. Frequency and duration of outages on the Serrano–Villa Park No. 2 230-kV Transmission Line</li> </ul>
DR#5 Q.7	N/A	<b>Alternatives/ Objectives</b>	<p>SONGS has already been retired.</p> <ul style="list-style-type: none"> <li>A. State whether the project would be needed in 2020 if OTC units would <i>not</i> be retired by 2020 per the State Water Resources Control Board’s Policy on the Use of Coastal and Estuarine Waters for Power Plant Cooling.</li> <li>B. Provide substantiation to support SCE’s</li> </ul>

Item #	Reference/ Page #	Title	Request
			<p>response to A, such as a power flow diagram or data. Do not refer to the CAISO 2013–14 Transmission Plan in the answer to this question. The CPUC has reviewed and is aware of the CAISO plan and requests information other than, or in addition to, the information provided in that plan.</p>

## Attachment 2



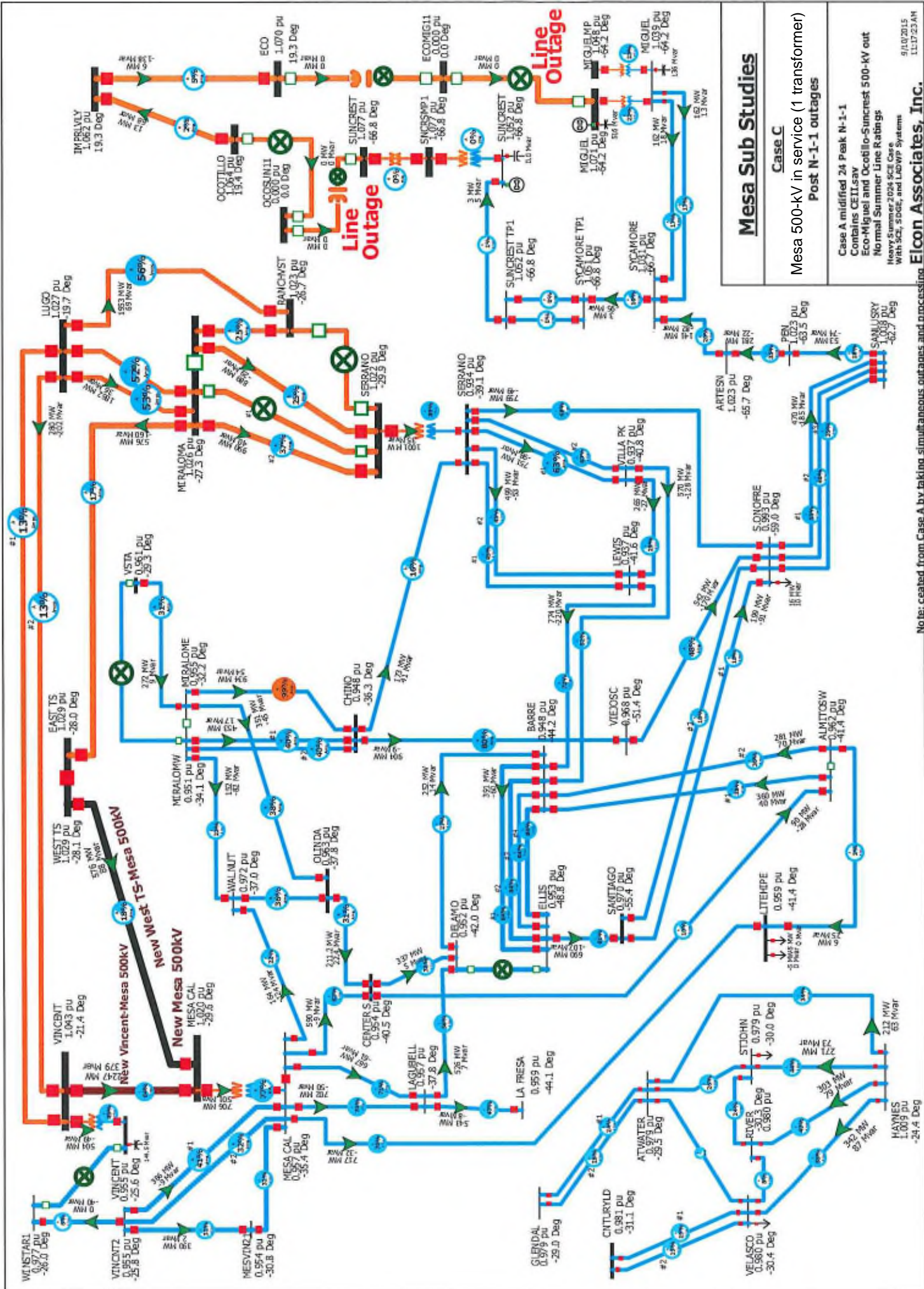

### Mesa Sub Studies

Case C  
Mesa 500-kV in service (1 transformer)  
Post N-1-1 outages

Case A modified 24 Peak N-1-1  
Contains CELLSAV  
Eco-Miguel and Ocotillo-Suncrest 500-kV out  
No small Summer Line Ratings  
Heavy Summer 2024 SCE Case  
With SCE, SDC, and LADWP Systems

Note: created from Case A by taking simultaneous outages and processing  
Eicon Associates, Inc.  
9/10/2016  
11:17:23 AM

## **Attachment 3**



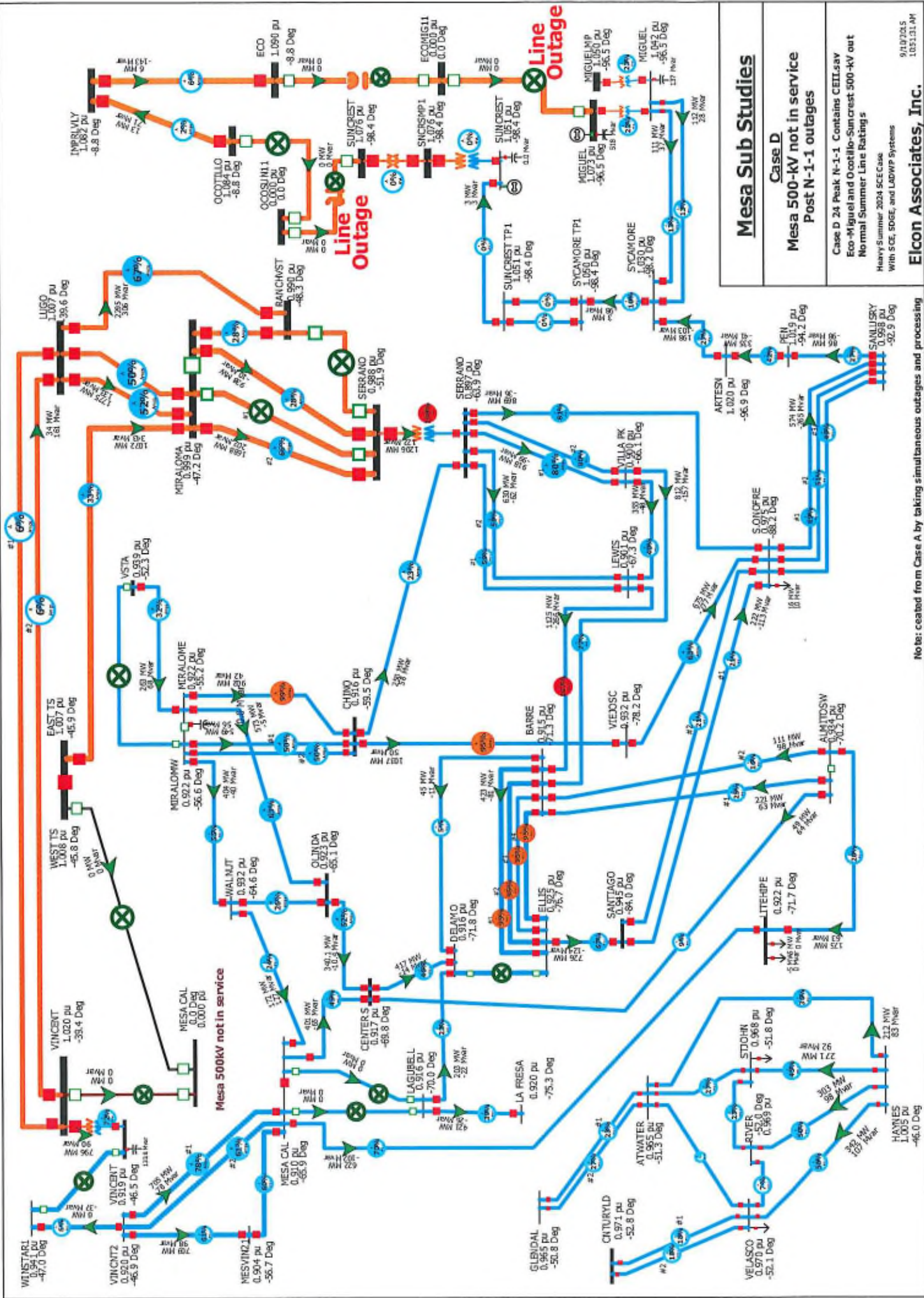

**Mesa Sub Studies**

**Case D**

**Mesa 500-kV not in service**

**Post N-1-1 outages**

Case D 24 Peak N-1-1 Contains CELLSAV  
Eco-Miguel and Ocotillo-Suncrest 500-kV out  
Normal Summer Line Ratings  
Heavy Summer 2024 SCE Case  
With SCE, SDGE, and LADWP Systems

**Elcon Associates, Inc.**

9/19/2025  
1.05:13:11 AM

Note: created from Case A by taking simultaneous outages and processing