STORM WATER POLLUTION PREVENTION PLAN (SWPPP)
FOR

SYCAMORE - PEÑASQUITOS
230 KV TRANSMISSION LINE PROJECT

Located in San Diego, California
San Diego Gas and Electric (SDG&E)

This SWPPP has been prepared in compliance with the **State Water Resources Control Board (SWRCB)** Order No. 2009-0009-DWQ as amended by Order Nos. 2010-0014-DWQ & 2012-0006-DWQ, National Pollutant Discharge Elimination System (NPDES) General Permit No. CAS000002 for Discharges of Storm Water Runoff Associated with Construction and Land Disturbance Activities.

WDID # <<<WDID Number>>>



A  Sempra Energy utility™

Prepared for:

San Diego Gas & Electric
8315 Century Park Court
San Diego, California 92123-1548
Phone Number: 858-503-5211

Prepared by:

TRC Solutions, Inc.
4393 Viewridge Ave, Suite A
San Diego, CA, 92123
858-505-8881

December, 2016

This Document Must Be Returned to
Edith Moreno – SX-PQ Environmental Compliance Lead, SD1116 at Job Completion

EMERGENCY CONTACT INFORMATION

Use the following contact numbers if there is an injury or other non-storm water related emergency occurs during the course the project:

SDG&E projects –

Life threatening: 911
Non-life threatening: (619) 725-5199 (Trouble Dispatch)

See Appendix XIII for the contact information for the Legally Responsible Person (LRP), Qualified SWPPP Developer (QSD), Qualified SWPPP Practitioner (QSP) and other parties responsible for the implementation of this SWPPP.

Table of Contents

EMERGENCY CONTACT INFORMATION	i
1.0 SWPPP APPROVAL AND CERTIFICATION	1
1.1 Qualified SWPPP Developer	1
1.2 Legally Responsible Person	2
2.0 GENERAL INFORMATION.....	3
2.1 Background	3
2.2 Permit Registration Documents (PRDs).....	3
2.3 SWPPP Amendments	3
2.4 Availability of the SWPPP	3
2.5 Anticipated Non-Compliance Reporting	4
2.6 Certifications	4
2.7 Soil Contamination	4
2.8 Responsible Parties.....	4
3.0 PROJECT INFORMATION	5
3.1 Overview	5
3.2 Project Characteristics	6
3.2.1 Project Location	6
3.2.2 Project Description.....	7
3.2.3 Staging Yards	8
3.2.4 Soil Disturbance and Total Area Estimate.....	9
3.2.5 Site Imperviousness.....	9
3.3 Receiving Waters	9
3.4 Wetlands	9
3.5 Non-Storm Water Discharges	10
3.6 Construction, BMP Implementation and Maintenance Schedules	11
3.7 Site Maps and Drawings.....	12
4.0 RISK TYPE SPECIFIC REQUIREMENTS	13
4.1 Project Risk Type Determination.....	13
4.2 Risk Type Requirements	13
5.0 MONITORING AND REPORTING PLAN	14
6.0 RECORD-KEEPING	15
6.1 Annual Reports	15
7.0 TRAINING	16

APPENDIX I – BLANK FORMS

Annual Reporting Form
BMP Selection Worksheet
Certification Form
Internal NAL Non-Compliance Documentation
Inventory of Potential Pollutant Sources Planned to Be Used or Stored at the Project Site
List of Responsible Parties
Notification of Anticipated Non-Compliance Form
Potential Materials Used or Stored
Record of PRDs Filed
QSP Implementation Checklist
Sample Chain of Custody Form
Sampling Event Worksheet
Secondary Containment and Spill Kit Inventory
Site Inspection Form
Spill/ Leak History Record
SWPPP Amendment Log
SWPPP Information Request Form
SWPPP Training and Qualifications Log
Visual Observation (Inspection) Form

APPENDIX II – COPY OF CONSTRUCTION GENERAL PERMIT

State Water Resources Control Board (SWRCB) Order No. 2009-0009-DWQ as amended by Order Nos. 2010-0014-DWQ & 2012-0006-DWQ, National Pollutant Discharge Elimination System (NPDES) General Permit No. CAS000002 Waste Discharge Requirements for Discharges of Storm Water Runoff Associated with Construction and Land Disturbance Activities

APPENDIX III – SITE MAPS AND DRAWINGS

(Retain in this appendix the current and all historic Site Maps; the original map is located in Appendix XII)

APPENDIX IV – CALCULATIONS/ ANALYSES/BACKGROUND INFORMATION

LUP Type Determination Analysis
Run-off Coefficient Calculations
Run-on Calculations
Particle Size Analysis Results
Alternative Type Analysis
Sediment Basin Sizing
SWPPP Information Request Form
Receiving Water Information, Including Applicable Water Quality Standards

APPENDIX V – CONSTRUCTION MATERIALS

Potential Materials Used or Stored
Inventory of Potential Pollutant Sources Planned to Be Used or Stored at the Project Site

APPENDIX VI – CONSTRUCTION BMPs

San Diego Gas & Electric Water Quality Construction Best Management Practices Manual
City of San Diego 2016 Storm Water Manual Construction Best Management Practices

APPENDIX VII – BMP INFORMATION

BMP Selection Worksheet
BMP Site Map (see Appendix III)
Final Landscaping and Site Stabilization BMPs
QSP Implementation Checklist

APPENDIX VIII – LUP TYPE REQUIREMENTS

- A. Risk Type 1
- B. Risk Type 2
- C. Risk Type 3

APPENDIX IX – SITE INSPECTION RECORDS

APPENDIX X – MONITORING AND REPORTING PLAN (M&RP)

- A. Risk Type 1
- B. Risk Type 2
- C. Risk Type 3

APPENDIX XI – M&RP ATTACHMENTS

- A. Completed Reports
 - Internal NAL Non-Compliance Documentation (Numeric Action Level Report located in Appendix XVII of the SWPPP)
- B. Sampling and Analysis Results
 - Sampling Event Worksheet
 - Field Meter Results
 - Calibration Records
 - Analytical Laboratory Results
- C. Completed Sample Forms
- D. RWQCB Correspondence: Additional Parameters for Storm Water Sampling
- E. Watershed Monitoring Option
- F. Contaminated Soil Documentation/ Notifications
- G. Completed Observation (Inspection) Forms
- H. Analytical Laboratory(ies)
 - I. Sample / Inspection Location Table
- J. Field QA/QC Document

APPENDIX XII – PERMIT REGISTRATION DOCUMENTS (PRDS)/ NOTICE OF TERMINATION (NOT)

PRDs, including:

- Record of PRDs Filed
- Notice of Intent (NOI)
- Site Maps and Drawings (original)
- SWPPP (electronic version, as submitted)
- Risk Determination
- Approved Signatory Delegation Letter
- Annual Fee (copy of check)
- Signed Certification Statement

Subsequent PRD Submittals

NOT, including:

- Application
- Receipt of Approval

APPENDIX XIII – RESPONSIBLE PARTIES

List of Responsible Parties, including

- LRP
- Approved Signatory
- QSD/ QSP
- Sampling personnel
- Inspection personnel
- Other SWPPP Implementation Personnel
- Non-Storm Water Management
- Project Contractors & Sub-Contractors List

Agency Contact Information

- Regional Water Quality Control Board
- Local Storm Water Management Agency

APPENDIX XIV – INSPECTION CHECKLISTS

Spill/ Leak History Record

APPENDIX XV – TRAINING DOCUMENTATION

Contractor Training

QSD

QSP (and personnel directed by QSP)

SWPPP Training and Qualifications Log

APPENDIX XVI – AMENDMENT LOG

SWPPP Amendment Log

APPENDIX XVII – REPORTS

Annual Report
NAL Exceedance Report
Anticipated Non-Compliance Reporting
Storm Water Reports
Bioassessment Study Reports

APPENDIX XVIII – SECONDARY CONTAINMENT AND SPILL KIT INVENTORY

Secondary Containment and Spill Kit Inventory

APPENDIX XIX – OTHER SWPPP EXHIBITS

APPENDIX XX - ACTIVE TREATMENT SYSTEM (ATS)

ATS Plan (if applicable)

APPENDIX XXI - BIOASSESSMENT

Study plan
RWQCB approval for payment in lieu of field study
Other documentation
Reports (see Appendix XVII)

APPENDIX XXII – GLOSSARY/ACRONYMS

APPENDIX XXIII – WEATHER TRACKING

1.0 SWPPP APPROVAL AND CERTIFICATION

1.1 Qualified SWPPP Developer

I, Christian Herencia, am a **Qualified Storm Water Pollution Prevention Plan (SWPPP) Developer** and certify that I have completed this SWPPP for the Sycamore - Peñasquitos 230 kilovolt Transmission Line Project and/or the amendments contained herein, in compliance with the **State Water Resources Control Board (SWRCB)** Order No. 2009-0009-DWQ as amended by Order Nos. 2010-0014-DWQ & 2012-0006-DWQ, National Pollutant Discharge Elimination System (NPDES) General Permit No. CAS000002 Waste Discharge Requirements for Discharges of Storm Water Runoff Associated with Construction and Land Disturbance Activities.

I certify under penalty of law that this document and all attachments were prepared under my direction or supervision in accordance with a system designed to assure that qualified personnel properly gather and evaluate the information submitted. Based on my inquiry of the person or persons who manage the system or those persons directly responsible for gathering the information, to the best of my knowledge and belief, the information submitted is true, accurate, and complete. I am aware that there are significant penalties for submitting false information, including the possibility of fine and imprisonment for knowing violations.

Signature: 

QSD Name: Christian Herencia

Title and Affiliation: Senior Project Engineer, TRC Solutions Inc. (TRC)

Date: December 6, 2016

Certificate Number: 00389

Telephone Number: (858-505-8881 ext.14923)

Email: CHerencia@TRCSolutions.com

1.2 Legally Responsible Person

I certify under penalty of law that this document and all attachments were prepared under my direction or supervision in accordance with a system designed to assure that qualified personnel properly gather and evaluate the information submitted. Based on my inquiry of the person or persons who manage the system or those persons directly responsible for gathering the information, to the best of my knowledge and belief, the information submitted is true, accurate, and complete. I am aware that there are significant penalties for submitting false information, including the possibility of fine and imprisonment for knowing violations.

Signature: _____

Name: Scott Pearson

Title: Director of Environmental Services

Company: San Diego Gas & Electric

Date: _____

Telephone Number: 858-654-3580

Email: spearson@semprautilities.com

2.0 GENERAL INFORMATION

2.1 Background

This SWPPP was prepared for the Sycamore – Peñasquitos 230 kilovolt (kV) Transmission Line Project, a linear construction project (“Project”).

This Storm Water Pollution Prevention Plan (SWPPP) has been prepared in accordance with the State Water Resources Control Board (SWRCB) Order No. 2009-0009-DWQ as amended by Order Nos. 2010-0014-DWQ & 2012-0006-DWQ, National Pollutant Discharge Elimination System (NPDES) General Permit No. CAS000002, Waste Discharge Requirements for Discharges of Storm Water Runoff Associated with Construction and Land Disturbance Activities (Construction General Permit) (hereto referred to as the CGP). The CGP became effective on July 17, 2012.

A copy of the CGP has been included in Appendix II of this SWPPP.

The goal of this SWPPP is to protect overall water quality during construction activities. Construction activities could potentially affect water quality by the storage and handling of various construction related materials as well as by causing soil erosion or sedimentation. With the implementation of the Best Management Practices (BMPs) and/or treatment outlined in this plan, the potential for the transport of contaminants or sediment to receiving waters will be minimized.

The SWPPP must be evaluated on an ongoing basis to document the changes and progression of construction activity throughout the life of the project.

2.2 Permit Registration Documents (PRDs)

The Project Registration Documents (PRDs) and the State Water Resources Control Board’s (SWRCB) confirmation of permit coverage (and associated Waste Discharge Identification Number) are contained in Appendix XII. Copies of PRD updates and annual fee checks are also contained in Appendix XII.

2.3 SWPPP Amendments

The Qualified SWPPP Developer (QSD) must prepare and certify each SWPPP amendment.

Blank SWPPP Amendment Log forms and Certification forms are located in Appendix I. The completed SWPPP Amendment Logs are located in Appendix XVI.

2.4 Availability of the SWPPP

The SWPPP shall be available at the construction site during working hours while construction is occurring and shall be made available upon request by State or Municipal inspectors. When the original SWPPP is retained by a crewmember in a construction vehicle and is not currently at the construction site, current copies of the BMPs and map/drawing will be left with the field crew and the original SWPPP shall be made available via a request by radio or telephone. The SWPPP shall be made

available by the Legally Responsible Person (LRP) until completion of construction activities and stabilization is achieved.

2.5 Anticipated Non-Compliance Reporting

If there is an anticipated non-compliance for the Project, an Anticipated Non-Compliance Form should be completed and retained in Appendix XVII.

This form must be completed and submitted in advance of the planned change in construction activity that may result in non-compliance with the CGP to the Regional Water Quality Control Board and local storm water management agency (see contact information in Appendix XIII).

2.6 Certifications

Certification requirements are described in Attachment A, Section E.9 and E.10 of the CGP.

2.7 Soil Contamination

If soil contamination is found, or suspected, and a responsible party is not identified, or the responsible party fails to promptly take the appropriate action, the LRP shall have those soils sampled and tested to ensure proper handling and public safety measures are implemented. Sampling and testing records shall be retained in Appendix XIV. The LRP shall notify the appropriate local, state, and federal agency(ies) when contaminated soil is found at a construction site, and will notify the appropriate Regional Water Quality Control Board through the Notice of Termination at the completion of the project.

LRPs shall ensure that trench spoils or any other soils disturbed during construction activities that are contaminated are not discharged with storm water or non-storm water discharges into any storm drain or water body except pursuant to a project specific NPDES permit.

2.8 Responsible Parties

Implementation of the SWPPP involves a number of responsible parties including, but not limited to, the Legally Responsible Person (LRP), Approved Signatory, Qualified SWPPP Developer (QSD) and Qualified SWPPP Practitioner (QSP). Additionally, other persons may be specifically responsible for conducting inspections, sampling, and BMP installation under the direction of the QSP. These responsible parties are identified in Appendix XIII.

3.0 PROJECT INFORMATION

3.1 Overview

San Diego Gas & Electric is dedicated to providing for the energy needs of its customers through the transmission and distribution of natural gas and/or electric services. The need to upgrade existing facilities and to construct new facilities in support of new development is the primary impetus for San Diego Gas & Electric construction projects.

The goal of this SWPPP is to protect overall water quality during construction activities. Construction activities could potentially affect water quality by the storage and handling of various construction-related materials as well as by causing soil erosion or sedimentation. With the implementation of the Best Management Practices (BMPs) outlined in this plan, the potential for the transport of contaminants or sediment to receiving waters will be minimized.

The Project will construct approximately 14 miles of 230 kV transmission line between the existing Sycamore Canyon and Peñasquitos Substations located in San Diego County.

The Project proposes the construction and operation of a 230 kV transmission line between the existing Sycamore Canyon and Peñasquitos substations. The Project route consists of approximately 14 miles traversing through developed residential and commercial areas as well as undeveloped areas and includes the following components:

- Segment A (includes SWPPP segments 1A and 2A) - Construction of approximately 0.74 mile of new 230 kV transmission line and relocated 138 kV power line on new tubular steel poles (monopole structures) and steel H-frame structures all within existing SDG&E right-of-way (ROW) located between the existing Sycamore Canyon Substation and a trail originating at Stonebridge Parkway. Construction of a new cable pole at the transition point from overhead to underground.
- Segment B (includes SWPPP segments 3B, 4B, and 5B) - Construction of approximately 11.45 miles of 230 kV underground transmission line in existing roads and bridges.
- Segment C (includes SWPPP segments 6C, 7C, and 8C) – Construction of approximately 2.2 miles of new 230 kV transmission line and all-dielectric self-supporting (ADSS) communication cable on existing 230 kV tubular steel poles within existing SDG&E ROW from Scranton Road to Peñasquitos Substation. Construction of a new cable pole at the transition point from underground to overhead.
- Minor modifications of the existing Sycamore Canyon and Peñasquitos substations to allow for connection of the new 230 kV transmission line.

The following sections provide a description of the project and its characteristics.

3.2 Project Characteristics

3.2.1 Project Location

The Project alignment extends from the Peñasquitos Substation in the west to the Sycamore Canyon Substation on Marine Corps Air Station (MCAS) Miramar in the east, in San Diego County, California. The Project begins as an overhead alignment at the Peñasquitos Substation in the west and heads southwest through a mix of commercial development and open space until Carroll Canyon Road. At Carroll Canyon Road, the Project takes a turn east and follows Carroll Canyon Road as an underground alignment alongside Poway Creek. The underground alignment continues to meander east through commercial development, crosses Interstate 15 (I-15), follows Pomerado Road and Stonebridge Parkway, and returns to an overhead position before terminating at the Sycamore Substation. The Project is located in the United States Geological Survey (USGS) Del Mar and Poway 7.5-minute quadrangles.

East End of Project	
Sycamore Canyon Substation	
ADDRESS	Spring Canyon Road
CITY, STATE, ZIP CODE	San Diego, CA 92131
THOMAS GUIDE LOCATION	2009, pg. 1210, G3, San Diego County
LATITUDE / LONGITUDE	32.917333°N, -117.030728°W

The Sycamore Canyon Substation is located between Stonebridge Parkway and Spring Canyon Road, east of Deprise Cove. To access the Sycamore Canyon Substation, the entrance (Spring Canyon Road) is located on Maple Grove Lane.

West End of Project	
Peñasquitos Substation	
ADDRESS	East Ocean Air Drive
CITY, STATE, ZIP CODE	San Diego, CA 92130
THOMAS GUIDE LOCATION	2009, pg. 1208, C3, San Diego County
LATITUDE / LONGITUDE	32.918247°N, -117.219228°W

The Peñasquitos Substation is located on the southeast quadrant between Carmel Mountain Road to the North and East Ocean Air Drive to the east. To access the Peñasquitos Substation, the entrance (Spring Canyon Road) is located on East Ocean Air Drive.

The project location is shown on the Site Maps included in Appendix III.

3.2.2 Project Description

This Project includes the following types of facilities:

Electric:

Overhead Underground Transmission Distribution Service

Gas:

Transmission Distribution Service

Other:

Access Road

Other:

Other:

This project will be constructed in the following types of areas:

Developed Areas Undeveloped Areas

Other:

The CGP identifies the following distinct phases of construction activities (listed below). Check the phases applicable to this Project:

- Grading and Land Development Phase
- Streets and Utilities Phase
- Vertical Construction Phase
- Final Landscaping and Site Stabilization, and
- Inactive Construction Phase (i.e., 14 or more days of inactivity).

This Project is not a part of a common plan of development or sale.

3.2.3 Staging Yards

There are 12 potential staging yards proposed for this project. Some of the staging yards are located on undeveloped land and may require the installation of Best Management Practices (BMPs). In addition, not all staging yards will be active during the life of the project. The table below identifies the staging yards and their corresponding acreage.

Staging Yard	Latitude/Longitude	Acreage
Stowe	Latitude: 32.94204°N, Longitude: -117.03604°W	3.55
Stonebridge	Latitude: 32.92124°N, Longitude: -117.03073°W	3.97
Site 1A	Latitude: 32.90268°N, Longitude: -117.12656°W	1.43
Site 1B	Latitude: 32.90104°N, Longitude: -117.12551°W	2.98
Site 2	Latitude: 32.8964°N, Longitude: -117.14716°W	1.25
Site 3	Latitude: 32.89394°N, Longitude: -117.15530°W	2.62
Shire Property (Sites 4A-4C)	Latitude: 32.89393°N, Longitude: -117.17209°W	Site 4A: 1.98 Site 4B: 1.16 Site 4C: 2.95
Driving Range (Site 5)	Latitude: 32.89105°N, Longitude: -117.19129°W	0.73
Evergreen Nursery	Latitude: 32.97245°N, Longitude: -117.16864°W	3.5
Carmel Valley Road	Latitude: 32.97828°N, Longitude: -117.14729°W	7.17

The acreage of each staging yard has been incorporated into the nearest construction segment (segments 1A thru 8C) and the appropriate risk level determination has been recalculated and revised. Based on the staging yard locations, Stowe and Stonebridge are included as part of construction Segment 2. The following staging yards, Site 1A, Site 1B, Site 2, Site 3, Shire Property (Sites 4A-4C), Driving Range (Site 5), Evergreen Nursery and Carmel Valley Road have been incorporated as part of construction Segment 5. It is noted that the staging yards may become active during construction activities as the need arises at any time during the life of the project.

The location of each staging yard is shown on the Site Maps included in Appendix III.

3.2.4 Soil Disturbance and Total Area Estimate

Based on the proposed construction activity and the criteria in Attachment A.2 of the CGP (“Calculating Land Disturbance Areas of LUPs”), the initial estimated soil disturbance area for this Project is 35.35 acres. Changes to the initial estimate will be documented in the copies of the revised Notice of Intent documents submitted to the SWRCB (see Appendix XII).

3.2.5 Site Imperviousness

Approximately 25% of the pre-project site is impervious, including staging areas. Runoff coefficient calculations and run-on flow calculations are found in Appendix IV.

3.3 Receiving Waters

This project is being constructed in the following hydrologic unit(s):

- 906.1 Los Peñasquitos Hydrologic Unit, Miramar Reservoir Hydrologic Area
- 906.2 Los Peñasquitos Hydrologic Unit, Poway Hydrologic Area

The receiving waters that are adjacent to the Project are an unnamed tributary to Beeler Creek, Soledad Canyon, Carroll Canyon and Los Peñasquitos Creek.

Additional receiving water information is included in the risk type determination(s) in Appendix IV.

3.4 Wetlands

No impacts to jurisdictional water bodies (e.g., waters of the United States or the State) are anticipated.

3.5 Non-Storm Water Discharges

Non-storm water discharges from the Project are prohibited unless they are specifically authorized by the permit.

The following checked discharges are **authorized non-storm water** discharges:

Discharge Source	Separate Permit Required?	
<input type="checkbox"/> Fire hydrant flushing	<input type="checkbox"/> Yes	<input type="checkbox"/> No
<input checked="" type="checkbox"/> Irrigation of vegetative erosion control measures	<input type="checkbox"/> Yes	<input checked="" type="checkbox"/> No
<input type="checkbox"/> Pipe flushing and testing	<input type="checkbox"/> Yes	<input type="checkbox"/> No
<input checked="" type="checkbox"/> Water to control dust	<input type="checkbox"/> Yes	<input checked="" type="checkbox"/> No
<input checked="" type="checkbox"/> Street cleaning	<input type="checkbox"/> Yes	<input checked="" type="checkbox"/> No
<input checked="" type="checkbox"/> Dewatering *	<input type="checkbox"/> Yes	<input checked="" type="checkbox"/> No
<input checked="" type="checkbox"/> Uncontaminated ground water from dewatering*	<input type="checkbox"/> Yes	<input checked="" type="checkbox"/> No
<input type="checkbox"/> Any other discharges not subject to a separate general NPDES permit adopted by a Regional Water Quality Control Board	<input type="checkbox"/> Yes	<input type="checkbox"/> No

* Dewatering operations will comply with the San Diego Regional Water Quality Control Board Conditional Waivers of Waste Discharge Requirements for Low Threat Discharges in the San Diego Region (Waivers) (Order No. R9-2014-0041)

The BMPs for these discharges are included in Appendix VI.

Additionally, these authorized non-storm water discharges:

- Shall not cause or contribute to a violation of any water quality standard;
- Shall not violate any other provision of the CGP;
- Shall not violate any applicable Basin Plan;
- Shall comply with BMPs as described in the SWPPP;

- Shall not contain toxic constituents in toxic amounts or (other) significant quantities of pollutants;
- Shall be monitored and meet the applicable NALs and NELs; and
- Shall be reported by the discharger in the Annual Report.

If any of the above conditions are not satisfied, the discharge is not authorized by the CGP. The LRP shall notify the Regional Water Quality Control Board of any anticipated non-storm water discharges not authorized by the CGP to determine the need for a separate NPDES permit.

Wherever feasible, alternatives that do not result in the discharge of non-storm water, shall be implemented concurrently with the commencement of soil disturbing activities.

3.6 Construction, BMP Implementation and Maintenance Schedules

The overall construction schedule for this project is provided below.

Estimated Date Construction will begin: *December 1, 2016*

Estimated Completion Date: *June 20, 2018*

The construction schedule for each project area is found in the Type determination(s) located in Appendix IV.

Applicable BMPs identified in this SWPPP are to be installed concurrently with the initiation of work and as work progresses at each location and will be routinely inspected and maintained.

The schedule for the inspections and maintenance of the Final Landscaping and Site Stabilization BMPs is included in Appendix VII.

3.7 Site Maps and Drawings

The Site Maps and Drawings are included in Appendix III, along with any additional information that could not be included on the maps or drawings.

In accordance with the CGP, the site maps and drawings include:

- Project's surrounding area (vicinity map)
- Site layout and Project components
- Areas of soil disturbance and construction site boundaries including temporary work areas
- The locations of storm drain inlets and waterbodies that may receive discharge from the construction activities
- Flow direction
- The locations of all SWPPP BMPs
- The locations of staging yards and access (including entrance points and access roads) to the construction site.

As site conditions change it is the responsibility of the QSP to document and date the BMPs implemented at the site on the Site Map.

4.0 RISK TYPE SPECIFIC REQUIREMENTS

4.1 Project Risk Type Determination

Different Risk Types may be present within one project. The table below identifies the areas of the project split into areas that have different Risk Types. The areas identified, segments 1A through 8C, are based on Risk Type and preliminary construction schedule. The linear nature of this Project allowed for different segments to have different receiving water risks, and subsequently, different overall Risk Levels. The Risk Type determination analysis for each of these areas is contained in Appendix IV. Based upon these analyses, the segments listed below have the following Risk Types:

Segment	Risk Type	From		To	
		GPS	Description	GPS	Description
Segment 1A	1	32.91733 °N, -117.03073°W	Sycamore Canyon Substation	32.91983°N, -117.03223°W	MCAS Miramar Boundary
Segment 2A	1	32.91983°N, -117.03223°W	MCAS Miramar Boundary	32.92250°N, -117.04244°W	P5; Including staging yards: Stowe and Stonebridge
Segment 3B	1	32.92250°N, -117.04244°W	P5	32.89347°N, -117.11358°W	1-15 Bridge
Segment 4B	1	32.89347°N, -117.11358°W	1-15 Bridge	32.89361°N, -117.11801°W	1-15 Bridge Crossing
Segment 5B	1	32.89361°N, -117.11801°W	1-15	32.88984°N, -117.20303°W	Carroll Canyon; Including staging yards: Site 1A, Site 1B, Site 2, Site 3, Shire Property (Sites 4A-4C), Driving Range (Site 5), Evergreen Nursery and Carmel Valley
Segment 6C	2	32.88984°N, -117.20303°W	Carroll Canyon	32.89926°N, -117.20886°W	Coastal Zone South End Boundary
Segment 7C	3	32.89926°N, -117.20886°W	Coastal Zone South End Boundary	32.91185°N, -117.21662°W	Coastal Zone North End Boundary
Segment 8C	1	32.91185°N, -117.21662°W	Coastal Zone North End Boundary	32.91825°N, -117.21923°W	Peñasquitos Substation

If project conditions (e.g., time of year the construction is conducted or the duration of the construction activities) change during the project, the Risk Type for the applicable area will be re-evaluated.

4.2 Risk Type Requirements

Each Risk Type has specific permit requirements. These requirements can be found in Appendix VIII.

5.0 MONITORING AND REPORTING PLAN

Each Risk Type has specific permit requirements. These requirements can be found in Appendix X and the corresponding attachments are found in Appendix XI.

6.0 RECORD-KEEPING

A paper or electronic copy of all required records (except storm water monitoring records), including a copy of the SWPPP, shall be retained for three years from the date generated or date submitted, whichever is last. These records shall be available at the construction site until construction is completed. These documents may be retained in a crew member's vehicle and made available upon request.

The Regional Water Quality Control Board, State Water Board, or USEPA, shall be furnished within a reasonable time, any requested information to determine compliance with the CGP, including copies of records that are required to be kept by the CGP.

Records of all storm water monitoring information and copies of all reports shall be retained for a period of at least three years. These records may be retained off-site while construction is ongoing, but must be made available upon request. These records include:

- The date, place, time of facility inspections, sampling, visual observation (inspections), and/or measurements, including precipitation (rain gauge);
- The name (s) of individual(s) who performed the facility inspections, sampling, visual observation (inspections), and or measurements;
- The date and approximate time of analyses;
- The individual(s) who performed the analyses;
- A summary of all analytical results from the last three years, the method detection limits and reporting units, the analytical techniques or methods used, and all chain of custody forms;
- Quality assurance/quality control records and results;
- Non-storm water discharge inspections and visual observation (inspections) and storm water discharge visual observation records (see Section M.4.a in Attachment A of the CGP);
- Visual observation and sample collection exception records (see Section M.4.g. in Attachment A of the CGP); and
- The records of any corrective actions and follow-up activities that resulted from analytical results, visual observation (inspections), or inspections;
- Annual reports.

After three years, records associated with the SWPPP shall be retained in accordance with the company's record retention policy. These records can be found in Appendix XI in the SWPPP.

6.1 Annual Reports

The Annual Report must be certified by the LRP. A blank certification form is located in Appendix I. Include the signed certification form with the Annual Report submittal. Records of the Annual Reports are maintained in Appendix XVII of this SWPPP.

The LRP shall prepare and electronically submit an Annual Report no later than September 1 of each year.

7.0 TRAINING

The LRP shall ensure that all persons responsible for implementing requirements of the CGP are appropriately trained in accordance with the requirements described in Section H of Attachment A of the CGP and shall provide documentation of all training for persons responsible for implementing the requirements of the CGP in the Annual Reports.

Specific training conducted for the project and documentation for the training is the responsibility of the QSP.

Storm water pollution prevention training should be provided regularly by the LRP. Topics can include, but are not limited to:

- Spill prevention and response;
- Inspections;
- Locations and functions of sediment/erosion control devices;
- Good housekeeping;
- Sampling;
- Fines and penalties;
- Material management practices;
- ATS (as appropriate).

Blank Training Logs can be found in Appendix I. Attendance records for each training session are located in Appendix XV. Training relevant for the QSD, QSP and individuals directed by the QSP are also located in Appendix XV.

APPENDIX I
BLANK FORMS

ANNUAL REPORTING FORM
(Store Completed Forms in Appendix XVII)

Project Name Sycamore - Peñasquitos 230 kV Transmission Line Project
WDID Number _____

- Electronically submit no later than September 1 of each year
- Keep a copy in Appendix XVII of the SWPPP. Retain an electronic or paper copy for a minimum of three years after the date that the Annual Report is filed; after three years, retain in accordance with the company's record retention policy.

This Annual Reporting Form is for the period of _____ to _____ and includes the following documents:

Training Information: (See Appendix XV)

1. Documentation of all training for individuals responsible for all activities associated with compliance with this Construction General Permit (CGP);
2. Documentation of all training for individuals responsible for BMP installation, inspection, maintenance, and repair; and
3. Documentation of all training for individuals responsible for overseeing, revising, and amending the SWPPP.

Storm Water Monitoring Information: (See Appendix XI)

1. A summary and evaluation of all sampling and analysis results, including original laboratory reports;
2. The analytical method(s), method reporting unit(s), and method detection limit(s) of each analytical parameter (analytical results that are less than the method detection limit shall be reported as "less than the method detection limit");
3. A summary of all corrective actions taken during the compliance year;
4. Identification of any compliance activities or corrective actions that were not implemented;
5. A summary of all violations of the Construction General Permit (CGP);
6. The names of individual(s) who performed the facility inspections, sampling, visual observation (inspections), and/or measurements;
7. The date, place, time of facility inspections, sampling, visual observation (inspections), and/or measurements, including precipitation (rain gauge); and
8. The visual observation and sample collection exception records and reports specified in Attachment A of the CGP.

Refer to Section XVI of the CGP for additional information specific to the Annual Reporting Requirements.

BMP Selection Worksheet (Store Completed Forms in Appendix VII)

BMP No.	BMP Options (Additional BMPs shall be implemented as necessary to protect water quality as determined by field conditions)	Selected BMPs	Option 1	Option 2
Section 1 Sediment Controls				
BMP-1-02	Silt Fence	<input type="checkbox"/>	*_*_*	-SF-
BMP-1-03	Fiber Rolls	<input type="checkbox"/>	- - -	-FR-
BMP-1-04	Gravel Bag Berm	<input type="checkbox"/>	○○○	~GBB~
BMP-1-05	Sand Bag Barrier	<input type="checkbox"/>	●●●	-SBB-
BMP-1-06	Storm Drain Inlet Protection	<input type="checkbox"/>	□	-SDIP-
BMP-1-07	Tracking Controls	<input type="checkbox"/>	■	-TC-
BMP-1-08	Stockpile Management	<input type="checkbox"/>	◇	-SM-
Other – User Defined	BMP Description	<input type="checkbox"/>		
The following rows have been provided to add additional BMPs that may be required during the course of the project. QSD to provide this information as applicable.				
Other – User Defined	BMP Description:	<input type="checkbox"/>		
Section 2 Waste Management and Material Controls				
BMP-2-01	Material Delivery and Storage	<input type="checkbox"/>	»»»»»	-MDS-
BMP-2-02	Material Use	<input type="checkbox"/>	☀	-MV-
BMP-2-03	Spill Control	<input type="checkbox"/>	⬡	-SC-
BMP-2-04	Solid Waste Management	<input type="checkbox"/>	○-○-○	-SWM-
BMP-2-05	Hazardous Materials/Waste Management	<input type="checkbox"/>	▴	-HM/WM-
BMP-2-06	Contaminated Soil Management	<input type="checkbox"/>	◎	-CSM-

BMP Selection Worksheet (Store Completed Forms in Appendix VII)

BMP No.	BMP Options (Additional BMPs shall be implemented as necessary to protect water quality as determined by field conditions)	Selected BMPs	Option 1	Option 2
BMP-2-07	Sanitary/Septic Waste Management	<input type="checkbox"/>	▲	-S/SWM-
BMP-2-08	Liquid Waste Management	<input type="checkbox"/>	△	-LWM-
The following rows have been provided to add additional BMPs that may be required during the course of the project. QSD to provide this information as applicable.				
Other – User Defined	BMP Description:	<input type="checkbox"/>		
Section 3 Non-Storm Water Discharge Controls				
BMP-3-01	Dewatering Operations	<input type="checkbox"/>	☆	-DW-
BMP-3-02	Paving Operations	<input type="checkbox"/>	●-●-●	-PO-
BMP-3-03	Vehicle and Equipment Washing	<input type="checkbox"/>	⬠	-VEW-
BMP-3-04	Vehicle and Equipment Fueling	<input type="checkbox"/>	⬡	-VEF-
BMP-3-05	Concrete/Coring/Saw Cutting and Drilling Waste Management	<input type="checkbox"/>	⊗	-CWM-
BMP-3-06	Dewatering Utility Substructures and Vaults	<input type="checkbox"/>	▶	-DUS&V-
BMP-3-07	Vegetation Management including Mechanical and Chemical Weed Control	<input type="checkbox"/>	↔	-VM-
BMP-3-08	Over-Water Protection	<input type="checkbox"/>	⬢	-OWP-
BMP-3-09	Removal of Utility Location/Mark-Out Paint	<input type="checkbox"/>	⊕	-UL-
The following rows have been provided to add additional BMPs that may be required during the course of the project. QSD to provide this information as applicable.				
Other – User Defined	BMP Description:	<input type="checkbox"/>		

BMP Selection Worksheet
(Store Completed Forms in Appendix VII)

BMP No.	BMP Options (Additional BMPs shall be implemented as necessary to protect water quality as determined by field conditions)	Selected BMPs	Option 1	Option 2
Section 4 Erosion Control and Soil Stabilization				
BMP-4-01	Preservation of Existing Vegetation	<input type="checkbox"/>	▼	-PEV-
BMP-4-02	Temporary Soil Stabilization	<input type="checkbox"/>	■-■-■	-TSS-
BMP-4-03	Hydraulic Mulch	<input type="checkbox"/>	≈≈≈	-M-
BMP-4-04	Hydroseeding	<input type="checkbox"/>	>>>>	-BP-
BMP-4-05	Soil Binders	<input type="checkbox"/>	┌┌┌┌	-SOS-
BMP-4-06	Straw Mulch	<input type="checkbox"/>	««««	-S-
BMP-4-07	Geotextiles, Plastic Covers and Erosion Control Blankets/Mats	<input type="checkbox"/>	▣▣▣▣	-ECB-
BMP-4-08	Dust (Wind Erosion) Control	<input type="checkbox"/>	-WE-
The following rows have been provided to add additional BMPs that may be required during the course of the project. QSD to provide this information as applicable.				
Other – User Defined	BMP Description:	<input type="checkbox"/>		

BMP Selection Worksheet
(Store Completed Forms in Appendix VII)

BMP No.	BMP Options (Additional BMPs shall be implemented as necessary to protect water quality as determined by field conditions)	Selected BMPs	Option 1	Option 2
Section 5 Streambed Discharges and Crossings				
CASQA EC-10	Velocity Dissipation Devices	<input type="checkbox"/>	≡≡≡≡	-VDD-
CASQA EC-12	Streambank Stabilization	<input type="checkbox"/>	~~~~	-SBS-
CASQA NS-4	Temporary Stream Crossing	<input type="checkbox"/>	<<<<	-TSC-
CASQA NS-5	Clear Water Diversion	<input type="checkbox"/>	+++++	-CWD-
The following rows have been provided to add additional BMPs that may be required during the course of the project. QSD to provide this information as applicable.				
Other – User Defined	BMP Description:	<input type="checkbox"/>		

QSD CERTIFICATION FORM
(Store Completed Forms in Appendix XII)

Project Name Sycamore - Peñasquitos 230 kV Transmission Line Project

WDID Number _____

This certification is for:

(Check the appropriate box and provide a brief description of any amendment or the other certification being made.)

Amendment to SWPPP (Appendix XVI)

Other: _____

"I certify under penalty of law that this document and all attachments were prepared under my direction or supervision in accordance with a system designed to assure that qualified personnel properly gather and evaluate the information submitted. Based on my inquiry of the person or persons who manage the system or those persons directly responsible for gathering the information, to the best of my knowledge and belief, the information submitted is, true, accurate, and complete. I am aware that there are significant penalties for submitting false information, including the possibility of fine and imprisonment for knowing violations."

Name

Title

Company

Telephone Number

Signature

Date

NUMERIC ACTION LEVEL (NAL) EXCEEDANCE REPORT (Store Completed Forms in Appendix XVII)

Not applicable to Type 1 projects – only Type 2 or 3 if Regional Water Board requires

Project Name Sycamore – Peñasquitos 230 kV Transmission Line Project

WDID Number _____

Risk Level _____

Attach the following documents to this NAL Exceedance Report:

- The analytical method(s), method reporting unit(s), and method detection limit(s) of each analytical parameter (Appendix X)
- The completed Visual Observation (Inspection) form and the sampling event worksheet (Appendix XI)

Date and Time of Sampling Event _____

Weather Conditions _____

Name of NAL Preparer _____

NAL Preparer's Company/Title _____

Sample Identification Number	Location	Parameter pH/Turbidity	Reporting Units	Results

Daily Average Value:

NAL Limitation:

Describe the current BMPs associated with the effluent sample that exceeded the NAL

Were any corrective actions taken? If yes, describe below:

INVENTORY OF POTENTIAL POLLUTANT SOURCES PLANNED TO BE USED OR STORE AT THE PROJECT SITE (Completed Form Stored in Appendix V)

Project Name Sycamore – Peñasquitos 230 kV Transmission Line Project

WDID Number _____

Date _____

- Conduct an inventory of the products used and/or expected to be used and the end products that are produced and/or expected to be produced at the site.
- As a reference a list of possible products that are typically found at construction sites are listed in Appendix V.

Typical Materials Handled, Produced, Stored, Recycled, or Disposed of at the Site	Quantity (e.g., gal, lbs, oz)	Physical Characteristics (e.g., liquid, powder, solid)	Location and Containment	Distance to Storm Drain Inlet/Receiving Waters

**Inventory of Potential Pollutant Sources Planned to be Used or Store at the Project Site
(Completed Form Stored in Appendix V)**

Based on the table above, describe the degree to which pollutants associated with those materials may be exposed to and mobilized by contact with storm water (ie proximity to storm drain inlets or receiving waters).

Describe BMPs implemented to address these pollutant sources below:

Consider the direct and indirect pathways that pollutants may be exposed to storm water or authorized non-storm water discharges. This shall include an assessment of past spills or leaks, non-storm water discharges, and discharges from adjoining areas

Based on the inventory and evaluation above, describe the anticipated pollutants for the project below and include these analytes in the Monitoring & Reporting Program (M&RP) in Appendix X of the SWPPP.

Appendix XIII List of Responsible Parties

PROJECT: Sycamore – Peñasquitos 230 kV
Transmission Line Project

WDID NUMBER: _____

LEGALLY RESPONSIBLE PART (LRP) THE LRP's APPROVED SIGNATORY

AREA OF RESPONSIBILITY: _____

NAME _____

TITLE: _____

COMPANY NAME: _____

ADDRESS _____

CITY _____

STATE _____

ZIP _____

TELEPHONE _____

EMERGENCY TELEPHONE _____

FAX _____

E-MAIL _____

QUALIFIED SWPPP DEVELOPER (QSD): RESPONSIBLE FOR PREPARING THE SWPPP:

NAME _____

TITLE: _____

COMPANY NAME: _____

ADDRESS _____

CITY _____

STATE _____

ZIP _____

TELEPHONE _____

EMERGENCY TELEPHONE _____

FAX _____

E-MAIL _____

ADDITIONAL QSD:

AREA OF RESPONSIBILITY: _____

NAME _____

TITLE: _____

COMPANY NAME: _____

ADDRESS _____

CITY _____

STATE _____

ZIP _____

TELEPHONE _____

EMERGENCY TELEPHONE _____

FAX _____

E-MAIL _____

START DATE _____

END DATE _____

QUALIFIED SWPPP PRACTITIONER (QSP):

AREA OF RESPONSIBILITY: _____

NAME _____

TITLE: _____

COMPANY NAME: _____

ADDRESS _____

CITY _____

STATE _____

ZIP _____

TELEPHONE _____

EMERGENCY TELEPHONE _____

FAX _____

E-MAIL _____

START DATE _____

END DATE _____

ADDITIONAL QSP:

AREA OF RESPONSIBILITY: _____

NAME _____

TITLE: _____

COMPANY NAME: _____

ADDRESS _____

CITY _____

STATE _____

ZIP _____

TELEPHONE _____

EMERGENCY TELEPHONE _____

FAX _____

E-MAIL _____

START DATE _____

END DATE _____

SPILL RESPONSE PERSONNEL

NAME _____

TITLE: _____

ADDRESS _____

CITY _____

STATE _____

ZIP _____

TELEPHONE _____

EMERGENCY TELEPHONE _____

FAX _____

E-MAIL _____

START DATE _____

END DATE _____

SPILL RESPONSE PERSONNEL

NAME _____ TITLE: _____
ADDRESS _____
CITY _____ STATE _____ ZIP _____
TELEPHONE _____
EMERGENCY TELEPHONE _____
FAX _____
E-MAIL _____
START DATE _____ END DATE _____

SPILL RESPONSE PERSONNEL

NAME _____ TITLE: _____
ADDRESS _____
CITY _____ STATE _____ ZIP _____
TELEPHONE _____
EMERGENCY TELEPHONE _____
FAX _____
E-MAIL _____
START DATE _____ END DATE _____

SPILL RESPONSE PERSONNEL

NAME _____ TITLE: _____
ADDRESS _____
CITY _____ STATE _____ ZIP _____
TELEPHONE _____
EMERGENCY TELEPHONE _____
FAX _____
E-MAIL _____
START DATE _____ END DATE _____

STORM WATER SAMPLING AGENT:

CONTACT PERSON _____ TITLE: _____

ADDRESS _____

CITY _____ STATE _____ ZIP _____

TELEPHONE _____

EMERGENCY TELEPHONE _____

FAX _____

E-MAIL _____

START DATE _____ END DATE _____

STORM WATER SAMPLING AGENT:

CONTACT PERSON _____ TITLE: _____

ADDRESS _____

CITY _____ STATE _____ ZIP _____

TELEPHONE _____

EMERGENCY TELEPHONE _____

FAX _____

E-MAIL _____

START DATE _____ END DATE _____

STORM WATER SAMPLING AGENT:

CONTACT PERSON _____ TITLE: _____

ADDRESS _____

CITY _____ STATE _____ ZIP _____

TELEPHONE _____

EMERGENCY TELEPHONE _____

FAX _____

E-MAIL _____

START DATE _____ END DATE _____

STORM WATER SAMPLING AGENT:

CONTACT PERSON	_____	TITLE:	_____
ADDRESS	_____		
CITY	_____	STATE	_____
TELEPHONE	_____		
EMERGENCY TELEPHONE	_____		
FAX	_____		
E-MAIL	_____		
START DATE	_____	END DATE	_____

REGIONAL BOARD CONTACT INFORMATION	RQWQB NAME:	_____	
CONTACT PERSON	_____	TITLE:	_____
ADDRESS	_____		
CITY	_____	STATE	_____
TELEPHONE	_____		
EMERGENCY TELEPHONE	_____		
FAX	_____		
E-MAIL	_____		

LOCAL STORM WATER MANAGEMENT AGENCY	AGENCY NAME:	_____	
CONTACT PERSON	_____	TITLE:	_____
ADDRESS	_____		
CITY	_____	STATE	_____
TELEPHONE	_____		
EMERGENCY TELEPHONE	_____		
FAX	_____		
E-MAIL	_____		

CONTRACTOR SUBCONTRACTOR INDIVIDUAL DIRECTED BY QSP OTHER

PLEASE CHECK APPROPRIATE BOX ABOVE. IF "OTHER", PLEASE INDICATE:

COMPANY NAME _____
CONTACT PERSON _____ TITLE: _____
ADDRESS _____
CITY _____ STATE _____ ZIP _____
TELEPHONE _____
EMERGENCY TELEPHONE _____
FAX _____
E-MAIL _____
START DATE _____ END DATE _____

CONTRACTOR SUBCONTRACTOR INDIVIDUAL DIRECTED BY QSP OTHER

PLEASE CHECK APPROPRIATE BOX ABOVE. IF "OTHER", PLEASE INDICATE:

NAME _____ TITLE: _____
ADDRESS _____
CITY _____ STATE _____ ZIP _____
TELEPHONE _____
EMERGENCY TELEPHONE _____
FAX _____
E-MAIL _____
START DATE _____ END DATE _____

CONTRACTOR SUBCONTRACTOR INDIVIDUAL DIRECTED BY QSP OTHER

PLEASE CHECK APPROPRIATE BOX ABOVE. IF "OTHER", PLEASE INDICATE:

NAME _____ TITLE: _____
ADDRESS _____
CITY _____ STATE _____ ZIP _____
TELEPHONE _____
EMERGENCY TELEPHONE _____
FAX _____
E-MAIL _____
START DATE _____ END DATE _____

CONTRACTOR SUBCONTRACTOR INDIVIDUAL DIRECTED BY QSP OTHER

PLEASE CHECK APPROPRIATE BOX ABOVE. IF "OTHER", PLEASE INDICATE:

NAME _____ TITLE: _____

ADDRESS _____

CITY _____ STATE _____ ZIP _____

TELEPHONE _____

EMERGENCY TELEPHONE _____

FAX _____

E-MAIL _____

START DATE _____ END DATE _____

CONTRACTOR SUBCONTRACTOR INDIVIDUAL DIRECTED BY QSP OTHER

PLEASE CHECK APPROPRIATE BOX ABOVE. IF "OTHER", PLEASE INDICATE:

NAME _____ TITLE: _____

ADDRESS _____

CITY _____ STATE _____ ZIP _____

TELEPHONE _____

EMERGENCY TELEPHONE _____

FAX _____

E-MAIL _____

START DATE _____ END DATE _____

CONTRACTOR SUBCONTRACTOR INDIVIDUAL DIRECTED BY QSP OTHER

PLEASE CHECK APPROPRIATE BOX ABOVE. IF "OTHER", PLEASE INDICATE:

NAME _____ TITLE: _____

ADDRESS _____

CITY _____ STATE _____ ZIP _____

TELEPHONE _____

EMERGENCY TELEPHONE _____

FAX _____

E-MAIL _____

START DATE _____ END DATE _____

CONTRACTOR SUBCONTRACTOR INDIVIDUAL DIRECTED BY QSP OTHER

PLEASE CHECK APPROPRIATE BOX ABOVE. IF "OTHER", PLEASE INDICATE:

NAME _____ TITLE: _____

ADDRESS _____

CITY _____ STATE _____ ZIP _____

TELEPHONE _____

EMERGENCY TELEPHONE _____

FAX _____

E-MAIL _____

START DATE _____ END DATE _____

CONTRACTOR SUBCONTRACTOR INDIVIDUAL DIRECTED BY QSP OTHER

PLEASE CHECK APPROPRIATE BOX ABOVE. IF "OTHER", PLEASE INDICATE:

NAME _____ TITLE: _____

ADDRESS _____

CITY _____ STATE _____ ZIP _____

TELEPHONE _____

EMERGENCY TELEPHONE _____

FAX _____

E-MAIL _____

START DATE _____ END DATE _____

CONTRACTOR SUBCONTRACTOR INDIVIDUAL DIRECTED BY QSP OTHER

PLEASE CHECK APPROPRIATE BOX ABOVE. IF "OTHER", PLEASE INDICATE:

NAME _____ TITLE: _____

ADDRESS _____

CITY _____ STATE _____ ZIP _____

TELEPHONE _____

EMERGENCY TELEPHONE _____

FAX _____

E-MAIL _____

START DATE _____ END DATE _____

Record of PRD Filing (Store Completed Forms in Appendix XII)

PRDs were filed:

Copy of Submittal:

The following documents, except the Annual Fee which was mailed, were submitted electronically to the SWRCB:

- Notice of Intent (NOI) – Enclosed
- Risk Assessment – Enclosed
- Site Map – Enclosed
- Drawings - Enclosed
- Storm Water Pollution Prevention Plan – Enclosed
- Annual Fee – Enclosed
- Signed Certification Statement – Enclosed

QSP IMPLEMENTATION CHECKLIST (Store Completed Forms in Appendix VII)

The QSP completes this checklist prior to each phase of construction.

Phase of construction: _____

A. Good Site Management ("Housekeeping") Measures for Construction Materials:

Construction Materials Measures ID No.	Construction Materials Measures	BMP Option		Alternative BMP Option *Describe why BMP was not implemented	
		Implemented?			
		Y	N*		
CM-b	Cover and berm loose stockpiled construction materials that are not actively being used (i.e. soil, spoils, aggregate, fly-ash, stucco, hydrated lime, etc.).	BMP-2-01 BMP-2-02 BMP-2-03 BMP-2-04 BMP-2-05 BMP-2-06			
CM-c	Store chemicals in watertight containers (with appropriate secondary containment to prevent any spillage or leakage) or in a storage shed (completely enclosed).	BMP-2-01 BMP-2-02 BMP-2-03 BMP-2-04 BMP-2-05 BMP-2-06 BMP-2-07 BMP-2-08			
CM-d	Minimize exposure of construction materials with precipitation.	BMP 1-07			

¹ QSP to review List of Potential Pollutant Sources in Appendix V and complete an Inventory of Potential Pollutant Sources planned to be used or stored at the project site in Appendix V as well.

B. Good Site Management ("Housekeeping") Measures for Waste Management:

Construction Materials Measures ID No.	Construction Materials Measures	BMP Option		Alternative BMP Option *Describe why BMP was not implemented	
		Implemented?			
		Y	N*		
WM-a	Prevent disposal of any rinse or wash waters or materials on impervious or pervious site surfaces or into the storm drain system.	BMP 3-02 BMP 3-03 BMP 3-04 BMP 3-05 BMP 3-06 BMP 3-07 BMP 3-08 BMP 3-09			
WM-b	Ensure the containment of sanitation facilities (e.g., portable toilets) to prevent discharges of pollutants to the storm water drainage system or receiving water.	BMP 2-07			
WM-c	Clean or replace sanitation facilities and inspecting them regularly for leaks and spills.	BMP 2-07			

QSP IMPLEMENTATION CHECKLIST

B. Good Site Management ("Housekeeping") Measures for Waste Management:

Construction	Construction Materials Measures	BMP Option		Alternative BMP Option
WM-d	Cover waste disposal containers at the end of every business day and during a rain event.	BMP 2-01 BMP 2-02 BMP 2-03 BMP 2-04 BMP 2-05 BMP 2-06 BMP 2-07 BMP 2-08		
WM-e	Prevent discharges from waste disposal containers to the storm water drainage system or receiving water.	BMP 2-01 BMP 2-02 BMP 2-03 BMP 2-04 BMP 2-05 BMP 2-06 BMP 2-07 BMP 2-08		
WM-f	Contain and securely protect stockpiled waste material from wind and rain at all times unless actively being used.	BMP 1-08		
WM-g	Implement procedures that effectively address hazardous and non-hazardous spills.	BMP 2-03		
WM-h	Develop a spill response and implementation element of the SWPPP prior to commencement of construction activities. The SWPPP shall require that: <ul style="list-style-type: none"> Equipment and materials for cleanup of spills shall be available on site and that spills and leaks shall be cleaned up immediately and disposed of properly; and Appropriate spill response personnel are assigned and trained. 	BMP 2-03		
WM-i	Ensure the containment of concrete washout areas and other washout areas that may contain additional pollutants so there is no discharge into the underlying soil and onto the surrounding areas.	BMP 2-04		

C. Good Site Management ("Housekeeping") Measures for Vehicle Storage and Maintenance:

Construction Materials Measures		BMP Option		Alternative BMP Option
		Implemented?		
		Y	N*	*Describe why BMP was not implemented
VSM-a	Prevent oil, grease, or fuel to leak in to the ground, storm drains or surface waters.	BMP 3-03 BMP 3-04 BMP 3-05		
VSM-b	Place all equipment or vehicles, which are to be fueled, maintained and stored in a designated area fitted with appropriate BMPs.	BMP 2-03 BMP 2-02 BMP 3-03 BMP 3-04		

QSP IMPLEMENTATION CHECKLIST

C. Good Site Management ("Housekeeping") Measures for Vehicle Storage and Maintenance:

Construction Materials Measures		BMP Option		Alternative BMP Option
VSM-c	Clean leaks immediately and disposing of leaked materials properly.	BMP 2-03		

D. Good Site Management ("Housekeeping") Measures for Landscape Materials:

Landscape Materials Measures		BMP Option		Alternative BMP Option
		Implemented?		
		Y	N*	
LM-a	Contain stockpiled materials such as mulches and topsoil when they are not actively being used.	BMP 1-08 BMP 4-07 BMP 4-02		
LM-b	Contain fertilizers and other landscape materials when they are not actively being used.	BMP 1-08 BMP 2-01 BMP 2-02		
LM-c	Discontinuing the application of any erodible landscape material within 2 days before a forecasted rain event ² or during periods of precipitation.	BMP 3-07 BMP 2-02		
LM-d	Apply erodible landscape material at quantities and application rates according to manufacture recommendations or based on written specifications by knowledgeable and experienced field personnel.	BMP 3-07 BMP 2-02		
LM-e	Stacking erodible landscape material on pallets and covering or storing such materials when not being used or applied.	BMP 3-07 BMP 2-01 BMP 2-02		

² Excerpt from CGP – 50% or greater chance of producing precipitation.

F. Good Site Management ("Housekeeping") Measures for Air Deposition:

Air Deposition		BMP Option		Alternative BMP Option
		Implemented?		
		Y	N*	
AD-a	Control the air deposition of site materials and from site operations. Such particulates can include, but are not limited to, sediment, nutrients, trash, metals, bacteria, oil and grease and organics.	BMP 4-08		

QSP IMPLEMENTATION CHECKLIST

Non-Storm Water Management:		BMP Option		Alternative BMP Option
		Implemented?		*Describe why BMP was not implemented
		Y	N*	
NSWM-a	Implement measures to control all non-storm water discharges during construction.	BMP 3-03 BMP 3-02 BMP 1-07		
NSWM-b	Wash vehicles in such a manner as to prevent non-storm water discharges to surface waters or MS4 drainage systems.	BMP 3-03		
NSWM-c	Clean streets in such a manner as to prevent non-storm water discharges from reaching surface water or MS4 drainage systems.	BMP 3-02 BMP 1-07		

² Inactive areas of construction are areas of construction activity that have been disturbed and are not scheduled to be re-disturbed for at least 14 days.

Erosion Control		BMP Option		Alternative BMP Option
		Implemented?		*Describe why BMP was not implemented
		Y	N*	
ECM-a	Effective wind erosion control	BMP 4-08		
ECM-b	Provide effective soil cover for inactive ³ areas and all finished slopes, open space, utility backfill, and completed lots.	BMP 4-02 BMP 4-03 BMP 4-04 BMP 4-05 BMP 4-06 BMP 4-07		
ECM-c	Limit the use of plastic materials when more sustainable, environmentally friendly alternatives exist. Where plastic materials are deemed necessary, the discharger shall consider the use of plastic materials resistant to solar degradation.	BMP 4-07		

³ Inactive areas of construction are areas of construction activity that have been disturbed and are not scheduled to be re-disturbed for at least 14 days.

QSP IMPLEMENTATION CHECKLIST

Sediment Control: SC-c, SC-d, SC-e, SC-f, SC-g, SC-h are not applicable to Risk Level 1 projects. If the project is a Risk Level 1, delete SC-c, SC-d, SC-e, SC-f, SC-g, SC-h in the table below. SC-h also does not apply to Risk Level 2 projects; delete this BMP if the project is Risk Level 2.

Sediment Control		BMP Option		Alternative BMP Option
		Implemented?		*Describe why BMP was not implemented
		Y	N*	
SC-a	Establish and maintain effective perimeter controls and stabilize all construction entrances and exits to sufficiently control erosion and sediment discharges from the site.	BMP 1-01 BMP 1-02 BMP 1-03 BMP 1-04 BMP 1-05 BMP 1-06 BMP 1-07 BMP 1-08		
SC-b	On sites where sediment basins are to be used, at a minimum, design sediment basins according to the method provided in CASQA's Construction BMP Guidance Handbook	N/A		

Excerpt from the CGP Attachment D and E (Only applicable to Risk Level 2 and 3):

Table 1 - Critical Slope/Sheet Flow Length Combinations

Slope Percentage	Sheet flow length not to exceed
0-25%	20 feet
25-50%	15 feet
Over 50%	10 feet

Run-on and Run-off Controls		Applicable to Project?		Alternative BMP Option
		Y	N*	*Describe why BMP was not implemented
RRC-a	Effectively manage all run-on, all runoff within the site and all runoff that discharges off the site.			
RRC-b	Run-on from off-site shall be directed away from all disturbed areas or shall collectively be in compliance with the effluent limitation in the CGP.			



CHAIN OF CUSTODY/SAMPLE SUBMITTAL FORM
 ENVIRONMENTAL ANALYSIS LABORATORY
 6555 Nancy Ridge Drive, Suite 300, San Diego, CA 92121-3221
 Office: 619-260-5747 Fax: 858-514-0154

LAB NO.

WORK ID	CLIENT'S NAME	CLIENT CODE
SAMPLED BY (Print & Signature)	CLIENT'S PHONE	PROJECT CODE
CLIENT'S ADDRESS	No. OF CONTAINERS	DUE DATE

SAMPLE ID	DATE	TIME	SAMPLE TYPE	SAMPLE CONTAINER	PRESERVATION	ANALYSIS NEEDED	TEST CODE(S)

COMMENTS

RELEASING	DATE	TIME	ACCEPTING	DATE	TIME
RELEASING	DATE	TIME	ACCEPTING	DATE	TIME

SAMPLING EVENT WORKSHEET (Store Completed Forms in Attachment B of Appendix XI)

Not applicable for Risk Level 1 projects.

to be submitted to the SWRCB within 5 days after the conclusion of the storm event

Name of Inspector: _____

Storm Event Date(s): _____

Rain Gauge Readings: _____

Samples collected:

Qualifying Rain Event

Non-Storm Water Discharge

(producing precipitation of ½ inch or more with a 48 hour or greater period between rain events)

Samples not collected:

Event was not preceded by 72 hours of dry weather

Event occurred outside of business hours

False Alert – Predicted storm event never started or did not produce runoff

Compliance Storm Event Exception

Dangerous Conditions

Storm Start Time:		Storm End Time:	
-------------------	--	-----------------	--

Runoff Start Time:		Total Precipitation:	
--------------------	--	----------------------	--

Check All That Apply (complete form for each sampling location per day):

Grab samples were collected of stored or contained storm water from discharges subsequent to a Qualifying Rain Event

Run-off location

Run-on location

ATS discharge location

Receiving Water Location

Type of Analysis (check all that apply):

Effluent Monitoring: 3 samples to be collected per day. This is sample:
 Sample 1 Sample 2 Sample 3

Effluent Sampled for:

pH
 Turbidity
 Any additional parameters for which monitoring is required by the Regional
Water Board:

Non-visible pollutant location

Who collected the sample? Name, company, phone number? Rain gauge readings?

Name:

Company:

Phone Number

Who collected the sample? Name, company, phone number? Rain gauge readings?

Name:

Company:

Phone Number

Who collected the sample? Name, company, phone number? Rain gauge readings?

Name:

Company:

Phone Number

Who collected the sample? Name, company, phone number? Rain gauge readings?

Name:

Company:

Phone Number

Effluent Monitoring Location: _____

		Sampler Name	Time Sample Taken	Results	Daily Average	Was there an NAL Exceedance (Y ¹ / N ²)	Was there an NEL Violation (Y ³ /N ²)
pH	1 st Sample						
	2 nd Sample						
	3 rd Sample						
Turbidity	1 st Sample						
	2 nd Sample						
	3 rd Sample						
SSC							

¹ Refer to Appendix X.7 for required action.
² No further action required.
³ Refer to Appendix X.8 for required action.

SECONDARY CONTAINMENT AND SPILL KIT INVENTORY (Store Completed Form in Appendix XVIII)

To be completed by the QSP

- Equipment and materials for cleanup of spills shall be available on site and spills and leaks shall be cleaned up **immediately** and the materials used to clean up the spills shall be disposed of properly; and
- Ensure appropriate spill response personnel are assigned and trained.
- Ensure the containment of washout areas that may contain additional pollutants so that there is no discharge into the underlying soil and/or surrounding areas.

The following spill control equipment can be found on-site:

Quantity ¹	Description ²	Location ³	Absorbent Capacity (Gallons) ⁴

1 – Number of spill kits or product
 2 - Contents of spill kit or product

3 – Storage location of spill kit or product
 4 – Absorbent capacity of the spill kit or product

Note: Spill response kits come from a variety of suppliers. Kit contents and absorbent capacity may vary from supplier’s description.

The following secondary containment equipment can be found on-site:

Description of Material Stored in Secondary Containment ⁵	Location ⁶	Type of Containment/Enclosure ⁷	Volume	
			Maximum Storage/Containment ⁸	Spill Potential ⁹

5- For example, paint, oil, lubricant, solvent, etc.

6- Location of secondary containment

7- Description of the secondary containment enclosure. For example, poly-pack, poly-pallet, cabinet, visqueen-lined sump.

8- Capacity of the secondary device (usually identified on the device or can be obtained from the manufacturer)

9- Quantity of material (in gallons) stored in the secondary containment

SITE INSPECTION FORM
(Store Completed Form in Appendix IX)

Project Name	Sycamore - Peñasquitos 230 kV Transmission Line Project
WDID Number	
Date of Inspection	
Date Inspection Report was Written	
Name of QSP*	
Inspector's Company/Title	
Inspector's Signature	
Inspection Type	
<input type="checkbox"/> Weekly	
<input type="checkbox"/> 24 Hour Interval During Extended Storm Events	
Date storm began: _____	Duration of Storm : _____
Rainfall Amount (inches): _____	Precipitation: <input type="checkbox"/> Present <input type="checkbox"/> Absent
Time elapsed since last storm (hours or days) _____	

*Or individual conducting the inspection that has been trained by the QSP (herein referred to as Inspector).

Is the site safely accessible during inclement weather? YES NO

If yes, complete the following pages to list the observations of all BMPs: erosion controls, sediment controls, chemical and waste controls, and non-storm water controls.

If no, list why not safely accessible.

Conduct a visual inspection at all relevant outfalls, discharge points, downstream locations and any projected maintenance activities. Document observations on the following pages.

A site map is attached that supplements this inspection form YES NO

Were photographs taken during the inspection? YES NO

BMP No.	BMP Options (Additional BMPs shall be implemented as necessary to protect water quality as determined by field conditions)	Selected BMPs
BMP-1-02	Silt Fence	<input type="checkbox"/>
BMP-1-03	Fiber Rolls	<input type="checkbox"/>
BMP-1-04	Gravel Bag Berm	<input type="checkbox"/>
BMP-1-05	Sand Bag Barrier	<input type="checkbox"/>
BMP-1-06	Storm Drain Inlet Protection	<input type="checkbox"/>
BMP-1-07	Tracking Controls	<input type="checkbox"/>
BMP-1-08	Stockpile Management	<input type="checkbox"/>
BMP-2-01	Material Delivery and Storage	<input type="checkbox"/>
BMP-2-02	Material Use	<input type="checkbox"/>
BMP-2-03	Spill Control	<input type="checkbox"/>
BMP-2-04	Solid Waste Management	<input type="checkbox"/>
BMP-2-05	Hazardous Materials/Waste Management	<input type="checkbox"/>
BMP-2-06	Contaminated Soil Management	<input type="checkbox"/>
BMP-2-07	Sanitary/Septic Waste Management	<input type="checkbox"/>
BMP-2-08	Liquid Waste Management	<input type="checkbox"/>
BMP-3-01	Dewatering Operations	<input type="checkbox"/>
BMP-3-02	Paving Operations	<input type="checkbox"/>
BMP-3-03	Vehicle and Equipment Washing	<input type="checkbox"/>
BMP-3-04	Vehicle and Equipment Fueling	<input type="checkbox"/>
BMP-3-05	Concrete/Coring/Saw Cutting and Drilling Waste Management	<input type="checkbox"/>
BMP-3-06	Dewatering Utility Substructures and Vaults	<input type="checkbox"/>
BMP-3-07	Vegetation Management including Mechanical and Chemical Weed Control	<input type="checkbox"/>
BMP-3-08	Over-Water Protection	<input type="checkbox"/>
BMP-3-09	Removal of Utility Location/Mark-Out Paint	<input type="checkbox"/>
BMP-4-01	Preservation of Existing Vegetation	<input type="checkbox"/>
BMP-4-02	Temporary Soil Stabilization	<input type="checkbox"/>
BMP-4-03	Hydraulic Mulch	<input type="checkbox"/>
BMP-4-04	Hydroseeding	<input type="checkbox"/>
BMP-4-05	Soil Binders	<input type="checkbox"/>
BMP-4-06	Straw Mulch	<input type="checkbox"/>
BMP-4-07	Geotextiles, Plastic Covers and Erosion Control Blankets/Mats	<input type="checkbox"/>
BMP-4-08	Dust (Wind Erosion) Control	<input type="checkbox"/>
CASQA EC-10	Velocity Dissipation Devices	<input type="checkbox"/>
CASQA EC-12	Streambank Stabilization	<input type="checkbox"/>
CASQA NS-4	Temporary Stream Crossing	<input type="checkbox"/>
CASQA NS-5	Clear Water Diversion	<input type="checkbox"/>

Site Information		
Current stage of construction (check which applies)	<input type="checkbox"/> Grading and Land Development Phase <input type="checkbox"/> Streets and Utilities Phase <input type="checkbox"/> Inactive Construction	<input type="checkbox"/> Final Landscaping and Site Stabilization <input type="checkbox"/> Vertical Construction Phase
Activities completed:		
Approximate area of the site exposed (in acres):		

Review and update (as applicable) the QSP Implementation Checklist in Appendix VIII. Based on a review of this checklist and an evaluation of BMPs on-site complete the following:

Inspected the site for good site management (i.e., "housekeeping") measures implemented for <u>Construction Materials</u>		
Were any BMP deficiencies observed (i.e., BMPs requiring maintenance and repair)?	<input type="checkbox"/> Yes*	<input type="checkbox"/> No
*If yes, describe the deficiency:		
Describe any BMP Corrective Actions:		
Date	BMP Corrective Action Taken	
Date		
Date		
Date		

Inspected the site for good site management (i.e., "housekeeping") measures implemented for <u>Waste Management</u> :	
Were any BMP deficiencies observed (i.e., BMPs requiring maintenance and repair)?	<input type="checkbox"/> Yes* <input type="checkbox"/> No
*If yes, describe below:	
Describe any BMP Corrective Actions:	
Date	BMP Corrective Action Taken
Date	
Date	
Date	

Inspected the site for good site management (i.e., "housekeeping") measures implemented for <u>Vehicle Storage and Maintenance</u> :	
Were any BMP deficiencies observed (i.e., BMPs requiring maintenance and repair)?	<input type="checkbox"/> Yes* <input type="checkbox"/> No
*If yes, describe below:	
Describe any BMP Corrective Actions:	
Date	BMP Corrective Action Taken
Date	
Date	
Date	

Inspected the site for good site management (i.e., "housekeeping") measures implemented for Landscape Materials:

Were any BMP deficiencies observed (i.e., BMPs requiring maintenance and repair)? *If yes, describe below:	<input type="checkbox"/> Yes*	<input type="checkbox"/> No
---	-------------------------------	-----------------------------

Describe any BMP Corrective Actions:	
Date	BMP Corrective Action Taken
Date	
Date	
Date	

Inspected the site for good site management (i.e., "housekeeping") measures implemented for Air Deposition:

Were any BMP deficiencies observed (i.e., BMPs requiring maintenance and repair)? *If yes, describe below:	<input type="checkbox"/> Yes*	<input type="checkbox"/> No
---	-------------------------------	-----------------------------

Describe any BMP Corrective Actions:	
Date	BMP Corrective Action Taken
Date	
Date	
Date	

Inspected the site for good site management (i.e., "housekeeping") measures implemented for <u>Non-Storm Water Discharges</u> :		
Were any BMP deficiencies observed (i.e., BMPs requiring maintenance and repair)? *If yes, describe below:	<input type="checkbox"/> Yes*	<input type="checkbox"/> No
Describe any BMP Corrective Actions:		
Date	BMP Corrective Action Taken	
Date		
Date		
Date		

Inspected the site for good site management (i.e., "housekeeping") measures implemented for <u>Erosion Control</u> :			<input type="checkbox"/> Yes	<input type="checkbox"/> No
Were any BMP deficiencies observed (i.e., BMPs requiring maintenance and repair)? *If yes, describe below:	<input type="checkbox"/> Yes*	<input type="checkbox"/> No		
Describe any BMP Corrective Actions:				
Date	BMP Corrective Action Taken			
Date				
Date				
Date				

Inspected the site for good site management (i.e., "housekeeping") measures implemented for <u>Sediment Control</u> :		<input type="checkbox"/> Yes <input type="checkbox"/> No
Were any BMP deficiencies observed (i.e., BMPs requiring maintenance and repair)? *If yes, describe below:	<input type="checkbox"/> Yes*	<input type="checkbox"/> No
Describe any BMP Corrective Actions:		
Date	BMP Corrective Action Taken	
Date		
Date		
Date		

Inspected the site for good site management (i.e., "housekeeping") measures implemented for <u>Run-on and Runoff Controls</u> :		<input type="checkbox"/> Yes <input type="checkbox"/> No
Were any BMP deficiencies observed (i.e., BMPs requiring maintenance and repair)? *If yes, describe below:	<input type="checkbox"/> Yes*	<input type="checkbox"/> No
Describe any BMP Corrective Actions:		
Date	BMP Corrective Action Taken	
Date		
Date		
Date		

List any corrective actions required, including any necessary changes to the SWPPP and the associated implementation dates:

Report the presence of noticeable odors/visible sheen on the surface of any discharges immediately to _____ at _____ and document observations below:

SPILL/ LEAK HISTORY (Completed Form Stored in Appendix XIV)

Immediately report any leaks or spills to the LRP

Name Sycamore – Peñasquitos 230 kV Transmission
Line Project

Phone Number _____

Date & Time of incident or
time of discovery of spill: _____

Material Spilled: Liquid Solid Gas

What is it used for? _____

Known dangerous quantities? _____

MSDS available YES * NO

If yes, consult the MSDS sheet for appropriate handling, storage and disposal practices

Chemical or Trade Name _____

Estimate Amount *Gallons if liquid*
 Pounds if solid or gas
 Leaked or Spilled

Potential dangers (as appropriate) Fire Explosion Toxic Fumes & Fluids Threat to life or property

Other
(describe): _____

Cause and source of incident (e.g., human error, corrosion):

SWPPP INFORMATION REQUEST FORM (Store Completed Form in Appendix IV)

Number of Copies Needed of SWPPP: _____

For Contractor: _____

For Submittal: _____

For Personal File (Project Manager): _____

Project Information

Project Name (exact project name to call SWPPP)

Project ID/Work Order/Contract Number/Request Number (if applicable)

Contact at SDG&E/SoCalGas to Return SWPPP to at job completion

Company Name and Division: _____
Street Address: _____
City, State, Zip Code: _____
Contact Person: _____
Contact Title: _____
Phone Number: _____
Emergency Phone Number: _____

Owner Information (Legally Responsible Party (LRP))

Owner Company Name: _____
Street Address: _____
City, State, Zip Code: _____
LRP Contact Person: _____
LRP Contact Title: _____
Phone Number: _____
Emergency Phone Number: _____

Duly Authorized Representative (LRP to assign this position), if applicable

Company Name: _____
Street Address: _____
City, State, Zip Code: _____
Contact Person: _____
Contact Title: _____
Phone Number: _____
Emergency Phone Number: _____

Qualified SWPPP Developer (QSD) Responsible for Preparation of SWPPP

QSD's Company Name: _____
Street Address: _____
City, State, Zip Code: _____
QSD (first and last name): _____
Type of Certification and Certification Number: _____

Phone Number: _____
Emergency Phone Number: _____

Qualified SWPPP Developer (QSD) Subsequent to SWPPP Preparation

QSD's Company Name: _____
Street Address: _____
City, State, Zip Code: _____
QSD (first and last name): _____
Type of Certification and Certification Number: _____

Phone Number: _____
Emergency Phone Number: _____

Qualified SWPPP Preparer (QSP)

QSD's Company Name: _____
Street Address: _____
City, State, Zip Code: _____
QSD (first and last name): _____
Type of Certification and Certification Number: _____

Phone Number: _____
Emergency Phone Number: _____

Contractor Information

Contractor Company Name: _____
Street Address: _____
City, State, Zip Code: _____
Contractor Contact Name: _____
Contractor's Title: _____
Phone Number: _____
Emergency Phone Number: _____

Storm Water Sampling Agent Information

Sampling Company Name: _____
Street Address: _____
City, State, Zip Code: _____
Contact Name: _____
Sampler's Title: _____
Phone Number: _____
Emergency Phone Number: _____

Site Information

Site Contact Person: _____
Phone Number: _____
Emergency Phone Number: _____

Project Description

Project description - describe the components of the proposed project

- Type of Construction: (Circle all that apply)

A. Residential C. Industrial E. Transportation
B. Commercial D. Development F. Utility
G. Other: _____

- Which of the following phases of construction are applicable to the project?

1. Grading and Land Development Phase
2. Streets and Utilities Phase
3. Vertical Construction Phase
4. Post-Construction Phase
5. Inactive Construction Phase

Project Location

- Site Address - (Examples: The project is located at 7910 Frost Street at the Northeast corner of the intersection of Frost St. and health Center Drive in the City of San Diego, County of San Diego. If there are no street address: W of I-15 N of I-8)

- Longitude and Latitude coordinates of project

- Thomas Brothers Guide location of project (year and page number(s))

- Construction Commencement date: _____

- % of construction site perimeter to be mass graded:

- Complete grading date: _____

- Completion project date: _____

- Percent Impervious Before and After Construction

- Runoff Coefficient Before and After Construction

- Number of acres to be disturbed as a result of the project (This will be referred to as construction site perimeter)

Onsite Acreage: _____

Offsite Acreage: _____

- Is this project part of a larger common plan of development? If so, please provide the name of the development.

- Number of acres to be left undisturbed (natural habitat) within the construction site perimeter defined above
-

- Determine the nearest rain gage
(See <http://www.cnrfc.noaa.gov/precipMaps.php?group=san&hour=24&synoptic=9>):
-

- Name of closest Receiving Water. See <http://bios.dfg.ca.gov/>
-

- Does the project drain to a Area of Special Biological Significance (ASBS) pursuant to the Ocean Plan?
-

- List receiving water impairments. For receiving water Impairments see:
http://www.waterboards.ca.gov/sandiego/water_issues/programs/303d_list/index.shtml
-

- Has setback distances been incorporated into the project design? If so, please explain and provide an exhibit showing these setbacks.
-

- Is the receiving water listed as a Beneficial Use for COLD, SPAWN or MIGRATORY?
-

- What Regional Board Jurisdiction does the project reside in?
See <http://maps.waterboards.ca.gov/webmap/rbound.html>
-

- Has a Drainage Study been prepared for the project? If so please provide the name of the study, date of the study and any revision dates. Also provide the information regarding who prepared the study. Provide a copy of the Drainage Study (please make sure that the drainage maps are attached/included in the report).
-
-

- Provide the discharges (and provide the storm event that the discharges are associated with, ie Q50 for 50-year storm event) for run-on (off-site area draining onto construction site), if any. Provide an exhibit that shows where all run-on locations occur.

- Has a Water Quality Technical Report (report addressing post-construction best management practices (BMPs)) been prepared? Is so, provide title, date, and preparer's information of the report. Also provide a copy of the report. If not, need to determine if the project resides in an area where a Phase I or Phase II Storm Water Management Plan has been approved. Discuss how to address Appendix 4 of the Construction General Permit (CGP) with the owner of the property that the project is located.

- Describe what Post-Construction BMP are being implemented for this project (if applicable):

Landscape Plans: _____

In-line Treatment: _____

Bio Swale: _____

Street Sweeping _____

Solid Waste Disposal _____

Controlled Use of Pesticides and Fertilizer: _____

Homeowners Association: _____

Other: _____

- Who is responsible for funding the Post-Construction BMPs both short and long term?

- Has a Spill Response and Implementation Procedure been prepared for the project?

- Are there any temporary Sediment Basins/Desilting Basins designed for the project? Have the basins been designed in conformance with Appendix 2 of the CGP? If yes, please provide all supporting calculations, a map showing the location of the basins and the details of the basins. If the basins have not been designed in conformance with Appendix 2 of the CGP please document below and consult with the person with whom respected this information.

- Does the project propose Active Treatment System (ATS)?

- Site History/Past Usage. Please provide a copy of the Phase I or Phase II Environmental Studies, if available. Has any environmental documents/studies been prepared for the project (such as California Environmental Quality Act (CEQA) or National Environmental Policy Act (NEPA). Please provide a copy. Document below what environmental studies if any have been prepared for the project. (Example: The site was previously a landfill or a gas station).

- If available, please provide copies of all Environmental Permits such as dewatering permits, demolition permits, CWA section 404 permit, CWA section 401 Water Quality Certification, and California Department of Fish and Game Code section 1600.

- Are you or the owner of the land that the project resides on aware of any toxic materials known to be treated or stored at the site? (Example: the site was used to store large quantities of gasoline in underground tanks). YES NO

If yes, please explain (provide documentation):

- Is this statement true: The primary impacts of wind erosion (dust control) will be controlled through water application on main driving areas, construction of gravel access road entrance/exits, and limitation of off-road driving? YES NO

- Are there any existing buildings or roadways within the construction site? If so list what kind of buildings are they and list road names, if any.

- Do you have a Construction Activity Schedule for this project at this time?

YES * NO * If yes, please attach a copy.

- Provide the information needed to access the construction drawings for the project. Have Erosion and Sediment Control Plans been prepared for the project? If so, please provide that information also.

SWPPP TRAINING AND QUALIFICATIONS LOG (Store Completed Form in Appendix XV)

Project Name: Sycamore – Peñasquitos 230 kV Transmission Line Project

WDID Number: _____

Training Location: _____

Trainer(s): _____ Date: _____

TRAINING TOPICS COVERED

- Review and Discussion of SWPPP
- General BMPs for Site and Materials Management
- BMPs for Erosion and Sediment Control
- Spill or Release Response
- Proper Selection of BMPs
- Proper BMP Implementation/Maintenance Techniques
- Review and Discussion of SWPPP Inspection Requirements
- Review and Discussion of Sampling Requirements
- Sampling and Monitoring
- Record Keeping
- Other: _____

NAME	AREA OF RESPONSIBILITY	COMPANY NAME	PHONE NUMBER

Qualified SWPPP Developer (QSD) Qualifications

I, _____, am a Qualified SWPPP Developer (QSD) and hold the following registration(s) and/or certification(s). (Check all that apply and include a copy of the registration(s) and/or certification(s)):

- A California registered professional civil engineer;
- A California registered professional geologist or engineering geologist;
- A California registered landscape architect;
- A professional hydrologist registered through the American Institute of Hydrology;
- A Certified Professional in Erosion and Sediment Control (CPESC)[™] registered through Enviro Cert, International, Inc.;
- A Certified Professional in Storm Water Quality (CPSWQ)[™] registered through Enviro Cert, International, Inc.; or
- A professional in erosion and sediment control registered through the National Institute for Certification in Engineering Technologies (NICET).

-- AND --

The QSD attended formal State Water Board sponsored or approved QSD training course on the following date (a requirement as of September 2, 2011):

Date: _____

Name of Course: _____

Presented by: _____

A copy of the certification of attendance is attached.

Signature: _____

Affix Certificate Number and/or Seal here:

Certificate Number _____

Seal:

Qualified SWPPP Practitioner (QSP) Qualifications

I, _____, am a Qualified SWPPP Practitioner (QSP)* and hold the following registration(s) and/or certification(s). (Check all that apply and include a copy of the registration(s) and/or certification(s)):

- Qualified SWPPP Developer (QSD)
- A certified erosion, sediment and storm water inspector registered through Enviro Cert, International, Inc.; or
- A certified inspector of sediment and erosion control registered through Certified Inspector of Sediment and Erosion Control, Inc.

* A requirement as of September 2, 2011, the QSP shall be either a QSD or have one of the above certifications:

-- AND --

The QSP attended formal State Water Board sponsored or approved QSP training course on the following date (a requirement as of September 2, 2011):

Date: _____

Name of Course: _____

Presented by: _____

A copy of the certification of attendance is attached.

Signature: _____

Affix Certificate Number and/or Seal here:

Certificate Number _____

Seal:

VISUAL OBSERVATION (INSPECTION) FORM FOR A QUALIFYING RAIN EVENT

(Store Complete Forms in Attachment G of Appendix XI)

Project Name: Sycamore - Peñasquitos 230 kV Transmission Line Project

WDID Number: _____

Date and Time of Inspection: _____

Current Weather Conditions: _____

Name of Inspector: _____

Inspector's Company/Title: _____

Inspector's Signature _____

Inspection Type Pre-rain 48 hours prior to a predicted qualifying rain event Post-Rain (within 48 hours after a qualifying rain event)

Stored or contained storm water being discharged that is derived from and discharged subsequent to a qualifying rain event producing 1/2 inch or more at the time of discharge Other: _____

Storm Event Date: _____

Site Rain Gauge Reading at Time of Inspection: _____

NOAA Rain Gauge Reading at Time of Inspection: _____

NOAA Rain Gauge ID: _____

Inspection Observations Are there any spills, leaks, or uncontrolled Yes* No pollutant sources? * If yes, describe below

Are BMPs improperly implemented in accordance with the SWPPP/REAP? Yes* No
* If yes, describe implemented corrective actions below

Do any storm water storage and containment areas have leaks? Yes* No
* If yes, describe below

All BMPs were adequately designed, implemented, and effective? Yes No*
If no, describe below:

Inspect all discharge locations. If any of the characteristics are observed, describe the conditions and discharge location(s) below.

Storm Water Characteristics	
Characteristic	Observation (Circle applicable response)
Discolorations	None Brown Gray Yellow Red Other _____
Turbidity	None Cloudy Opaque
Floating or Suspended Materials?	None Vegetation Mulch Trash Foam Other _____
Sheen	None Slight Heavy
Any observed pollutants? Possible sources?	None Sewage Other _____

Description of observations and location:

Is there a need for any additional BMPs? If so, describe below and inform the QSD that the SWPPP needs to be revised.

APPENDIX II
COPY OF CONSTRUCTION GENERAL PERMIT



Linda S. Adams
Secretary for
Environmental Protection

Arnold Schwarzenegger
Governor

CONSTRUCTION GENERAL PERMIT FACT SHEET TABLE OF CONTENTS

I. BACKGROUND 1

A. History 1

B. Legal Challenges and Court Decisions..... 1

C. Blue Ribbon Panel of Experts and Feasibility of Numeric Effluent Limitations 4

D. Summary of Panel Findings on Construction Activities 4

E. How the Panel’s Findings are Used in this General Permit 5

F. Summary of Significant Changes in This General Permit 5

II. RATIONALE 7

A. General Permit Approach..... 7

B. Construction Activities Covered..... 7

C. Construction Activities Not Covered 9

D. Obtaining and Terminating Permit Coverage 12

E. Discharge Prohibitions 12

F. Effluent Standards for All Types of Discharges..... 13

G. Receiving Water Limitations 20

H. Training Qualifications and Requirements 20

I. Sampling, Monitoring, Reporting and Record Keeping..... 21

J. Risk Determination..... 27

K. ATS Requirements..... 35

L. Post-Construction Requirements 37

M. Storm Water Pollution Prevention Plans 46

N. Regional Water Board Authorities..... 48

LIST OF TABLES

Table 1 - Regional Water Board Basin Plans, Water Quality Objectives for Turbidity	16
Table 2 - Results of Ecoregion Analysis	16
Table 3 – ACL Sampling Data taken by Regional Water Board Staff	17
Table 4 - Required Monitoring Elements for Risk Levels	21
Table 5 - Storm Water Effluent Monitoring Requirements by Risk Level	23
Table 6 - Receiving Water Monitoring Requirements	26
Table 7 - Combined Risk Level Matrix	29
Table 8 -National Oceanic and Atmospheric Administration (NOAA) Definition of Probability of Precipitation (PoP)	31
Table 9 - Qualified SWPPP Developer/ Qualified SWPPP Practitioner Certification Criteria	47

LIST OF FIGURES

Figure 1 -Statewide Map of K * LS	28
Figure 2 - Suite of Storm Events	37
Figure 3 - Northern CA (2009) Counties / Cities With SUSMP-Plus Coverage	39
Figure 4 - Southern CA (2009) Counties / Cities With SUSMP-Plus Coverage	40
Figure 5 - Schematic of the Lane Relationship	42
Figure 6 - Channel Changes Associated with Urbanization	43

I. BACKGROUND

A. History

In 1972, the Federal Water Pollution Control Act (also referred to as the Clean Water Act [CWA]) was amended to provide that the discharge of pollutants to waters of the United States from any point source is unlawful unless the discharge is in compliance with a National Pollutant Discharge Elimination System (NPDES) permit. The 1987 amendments to the CWA added Section 402(p), which establishes a framework for regulating municipal and industrial storm water discharges under the NPDES Program. On November 16, 1990, the U.S. Environmental Protection Agency (USEPA) published final regulations that established storm water permit application requirements for specified categories of industries. The regulations provide that discharges of storm water to waters of the United States from construction projects that encompass five or more acres of soil disturbance are effectively prohibited unless the discharge is in compliance with an NPDES Permit. Regulations (Phase II Rule) that became final on December 8, 1999 lowered the permitting threshold from five acres to one acre.

While federal regulations allow two permitting options for storm water discharges (Individual Permits and General Permits), the State Water Board has elected to adopt only one statewide General Permit at this time that will apply to most storm water discharges associated with construction activity.

On August 19, 1999, the State Water Board reissued the General Construction Storm Water Permit (Water Quality Order 99-08-DWQ). On December 8, 1999 the State Water Board amended Order 99-08-DWQ to apply to sites as small as one acre.

The General Permit accompanying this fact sheet regulates storm water runoff from construction sites. Regulating many storm water discharges under one permit will greatly reduce the administrative burden associated with permitting individual storm water discharges. To obtain coverage under this General Permit, dischargers shall electronically file the Permit Registration Documents (PRDs), which includes a Notice of Intent (NOI), Storm Water Pollution Prevention Plan (SWPPP), and other compliance related documents required by this General Permit and mail the appropriate permit fee to the State Water Board. It is expected that as the storm water program develops, the Regional Water Quality Control Boards (Regional Water Boards) may issue General Permits or Individual Permits containing more specific permit provisions. When this occurs, this General Permit will no longer regulate those dischargers.

B. Legal Challenges and Court Decisions

1. Early Court Decisions

Shortly after the passage of the CWA, the USEPA promulgated regulations exempting most storm water discharges from the NPDES permit requirements. (See 40 C.F.R. § 125.4 (1975); see also *Natural Resources Defense Council v. Costle* (D.C. Cir. 1977) 568 F.2d 1369, 1372 (*Costle*); *Defenders of Wildlife v. Browner* (9th Cir. 1999) 191 F.3d 1159, 1163 (*Defenders of Wildlife*)). When environmental groups challenged this exemption in federal court, the District of Columbia Court of Appeals invalidated the regulation, holding that the USEPA “does not have authority to exempt categories of point sources from the permit requirements of [CWA] § 402.” (*Costle*, 568 F.2d at 1377.) The *Costle* court rejected the USEPA’s argument that effluent-based storm sewer regulation was administratively infeasible because of the variable nature of storm water pollution and the number of affected storm sewers throughout the country. (*Id.* at 1377-82.) Although the court acknowledged the practical problems relating to storm sewer regulation, the court found the USEPA had the flexibility under the CWA to design regulations that would overcome these problems. (*Id.* at 1379-83.) In particular, the court pointed to general permits and permits based on requiring best management practices (BMPs).

During the next 15 years, the USEPA made numerous attempts to reconcile the statutory requirement of point source regulation with the practical problem of regulating possibly millions of diverse point source discharges of storm water. (See *Defenders of Wildlife*, 191 F.3d at 1163; see also Gallagher, Clean Water Act in Environmental Law Handbook (Sullivan, edit., 2003) p. 300 (Environmental Law Handbook); Eisen, *Toward a Sustainable Urbanism: Lessons from Federal Regulation of Urban Storm Water Runoff* (1995) 48 Wash. U.J. Urb. & Contemp. L.1, 40-41 [Regulation of Urban Storm Water Runoff].)

In 1987, Congress amended the CWA to require NPDES permits for storm water discharges. (See CWA § 402(p), 33 U.S.C. § 1342(p); *Defenders of Wildlife*, 191 F.3d at 1163; *Natural Resources Defense Council v. USEPA* (9th Cir. 1992) 966 F.2d 1292, 1296.) In these amendments, enacted as part of the Water Quality Act of 1987, Congress distinguished between industrial and municipal storm water discharges. With respect to industrial storm water discharges, Congress provided that NPDES permits "shall meet all applicable provisions of this section and section 1311 [requiring the USEPA to establish effluent limitations under specific timetables]." (CWA § 402(p)(3)(A), 33 U.S.C. § 1342(p)(3)(A); see also *Defenders of Wildlife*, 191 F.3d at 1163-64.)

In 1990, USEPA adopted regulations specifying what activities were considered "industrial" and thus required discharges of storm water associated with those activities to obtain coverage under NPDES permits. (55 Fed. Reg. 47,990 (1990); 40 C.F.R. § 122.26(b)(14).) Construction activities, deemed a subset of the industrial activities category, must also be regulated by an NPDES permit. (40 C.F.R. § 122.26(b)(14)(x)). In 1999, USEPA issued regulations for "Phase II" of storm water regulation, which required most small construction sites (1-5 acres) to be regulated under the NPDES program. (64 Fed. Reg. 68,722; 40 C.F.R. § 122.26(b)(15)(i).)

2. Court Decisions on Public Participation

Two recent federal court opinions have vacated USEPA rules that denied meaningful public review of NPDES permit conditions. On January 14, 2003, the Ninth Circuit Court of Appeals held that certain aspects of USEPA's Phase II regulations governing MS4s were invalid primarily because the general permit did not contain express requirements for public participation. (*Environmental Defense Center v. USEPA* (9th Cir. 2003) 344 F.3d 832.) Specifically, the court determined that applications for general permit coverage (including the Notice of Intent (NOI) and Storm Water Management Program (SWMP)) must be made available to the public, the applications must be reviewed and determined to meet the applicable standard by the permitting authority before coverage commences, and there must be a process to accommodate public hearings. (*Id.* at 852-54.) Similarly, on February 28, 2005, the Second Circuit Court of Appeals held that the USEPA's confined animal feeding operation (CAFO) rule violated the CWA because it allowed dischargers to write their own nutrient management plans without public review. (*Waterkeeper Alliance v. USEPA* (2d Cir. 2005) 399 F.3d 486.) Although neither decision involved the issuance of construction storm water permits, the State Water Board's Office of Chief Counsel has recommended that the new General Permit address the courts' rulings where feasible¹.

¹ In *Texas Independent Producers and Royalty Owners Assn. v. USEPA* (7th Cir. 2005) 410 F.3d 964, the Seventh Circuit Court of Appeals held that the USEPA's construction general permit was not required to provide the public with the opportunity for a public hearing on the Notice of Intent or Storm Water Pollution Prevention Plan. The Seventh Circuit briefly discussed why it agreed with the Ninth Circuit's dissent in *Environmental Defense Center*, but

The CWA and the USEPA's regulations provide states with the discretion to formulate permit terms, including specifying best management practices (BMPs), to achieve strict compliance with federal technology-based and water quality-based standards. (*Natural Resources Defense Council v. USEPA* (9th Cir. 1992) 966 F.2d 1292, 1308.) Accordingly, this General Permit has developed specific BMPs as well as numeric action levels (NALs) in order to achieve these minimum federal standards. In addition, the General Permit requires a SWPPP and REAP (another dynamic, site-specific plan) to be developed but has removed all language requiring the discharger to implement these plans – instead, the discharger is required to comply with specific requirements. By requiring the dischargers to implement these specific BMPs and NALs, this General Permit ensures that the dischargers do not “write their own permits.” As a result this General Permit does not require each discharger's SWPPP and REAP to be reviewed and approved by the Regional Water Boards.

This General Permit also requires dischargers to electronically file all permit-related compliance documents. These documents include, but are not limited to, NOIs, SWPPPs, annual reports, Notice of Terminations (NOTs), and numeric action level (NAL) exceedance reports. Electronically submitted compliance information is immediately available to the public, as well as the Regional Water Quality Control Board (Regional Water Board) offices, via the Internet. In addition, this General Permit enables public review and hearings on permit applications when appropriate. Under this General Permit, the public clearly has a meaningful opportunity to participate in the permitting process.

generally did not discuss the substantive holdings in *Environmental Defense Center and Waterkeeper Alliance*, because neither court addressed the initial question of whether the plaintiffs had standing to challenge the permits at issue. However, notwithstanding the Seventh Circuit's decision, it is not binding or controlling on the State Water Board because California is located within the Ninth Circuit.

C. Blue Ribbon Panel of Experts and Feasibility of Numeric Effluent Limitations

In 2005 and 2006, the State Water Board convened an expert panel (panel) to address the feasibility of numeric effluent limitations (NELs) in California's storm water permits. Specifically, the panel was asked to address:

"Is it technically feasible to establish numeric effluent limitations, or some other quantifiable limit, for inclusion in storm water permits? How would such limitations or criteria be established, and what information and data would be required?"

"The answers should address industrial general permits, construction general permits, and area-wide municipal permits. The answers should also address both technology-based limitations or criteria and water quality-based limitations or criteria. In evaluating establishment of any objective criteria, the panel should address all of the following:

The ability of the State Water Board to establish appropriate objective limitations or criteria;

How compliance determinations would be made;

The ability of dischargers and inspectors to monitor for compliance; and

The technical and financial ability of dischargers to comply with the limitations or criteria."

Through a series of public participation processes (State Water Board meetings, State Water Board workshops, and the solicitation of written comments), a number of water quality, public process and overall program effectiveness problems were identified. Some of these problems are addressed through this General Permit.

D. Summary of Panel Findings on Construction Activities

The panel's final report can be downloaded and viewed through links at www.waterboards.ca.gov or by clicking [here](#)².

The panel made the following observations:

"Limited field studies indicate that traditional erosion and sediment controls are highly variable in performance, resulting in highly variable turbidity levels in the site discharge."

"Site-to-site variability in runoff turbidity from undeveloped sites can also be quite large in many areas of California, particularly in more arid regions with less natural vegetative cover and steep slopes."

² http://www.waterboards.ca.gov/stormwtr/docs/numeric/swpanel_final_report.pdf

“Active treatment technologies involving the use of polymers with relatively large storage systems now exist that can provide much more consistent and very low discharge turbidity. However, these technologies have as yet only been applied to larger construction sites, generally five acres or greater. Furthermore, toxicity has been observed at some locations, although at the vast majority of sites, toxicity has not occurred. There is also the potential for an accidental large release of such chemicals with their use.”

“To date most of the construction permits have focused on TSS and turbidity, but have not addressed other, potentially significant pollutants such as phosphorus and an assortment of chemicals used at construction sites.”

“Currently, there is no required training or certification program for contractors, preparers of soil erosion and sediment control Storm Water Pollution Prevention Plans, or field inspectors.”

“The quality of storm water discharges from construction sites that effectively employ BMPs likely varies due to site conditions such as climate, soil, and topography.”

“The States of Oregon and Washington have recently adopted similar concepts to the Action Levels described earlier.”

In addition, the panel made the following conclusions:

“It is the consensus of the Panel that active treatment technologies make Numeric Limits technically feasible for pollutants commonly associated with storm water discharges from construction sites (e.g. TSS and turbidity) for larger construction sites. Technical practicalities and cost-effectiveness may make these technologies less feasible for smaller sites, including small drainages within a larger site, as these technologies have seen limited use at small construction sites. If chemical addition is not permitted, then Numeric Limits are not likely feasible.”

“The Board should consider Numeric Limits or Action Levels for other pollutants of relevance to construction sites, but in particular pH. It is of particular concern where fresh concrete or wash water from cement mixers/equipment is exposed to storm water.”

“The Board should consider the phased implementation of Numeric Limits and Action Levels, commensurate with the capacity of the dischargers and support industry to respond.”

E. How the Panel’s Findings are Used in this General Permit

The State Water Board carefully considered the findings of the panel and related public comments. The State Water Board also reviewed and considered the comments regarding statewide storm water policy and the reissuance of the Industrial General Permit. From the input received the State Water Board identified some permit and program performance gaps that are addressed in this General Permit. The Summary of Significant Changes (below) in this General Permit are a direct result of this process.

F. Summary of Significant Changes in This General Permit

The State Water Board has significant changes to Order 99-08-DWQ. This General Permit differs from Order 99-08-DWQ in the following significant ways:

Rainfall Erosivity Waiver: this General Permit includes the option allowing a small construction site (>1 and <5 acres) to self-certify if the rainfall erosivity value (R value) for their site's given location and time frame compute to be less than or equal to 5.

Technology-Based Numeric Action Levels: this General Permit includes NALs for pH and turbidity.

Risk-Based Permitting Approach: this General Permit establishes three levels of risk possible for a construction site. Risk is calculated in two parts: 1) Project Sediment Risk, and 2) Receiving Water Risk.

Minimum Requirements Specified: this General Permit imposes more minimum BMPs and requirements that were previously only required as elements of the SWPPP or were suggested by guidance.

Project Site Soil Characteristics Monitoring and Reporting: this General Permit provides the option for dischargers to monitor and report the soil characteristics at their project location. The primary purpose of this requirement is to provide better risk determination and eventually better program evaluation.

Effluent Monitoring and Reporting: this General Permit requires effluent monitoring and reporting for pH and turbidity in storm water discharges. The purpose of this monitoring is to evaluate whether NALs and NELs for Active Treatment Systems included in this General Permit are exceeded.

Receiving Water Monitoring and Reporting: this General Permit requires some Risk Level 3 and LUP Type 3 dischargers to monitor receiving waters and conduct bioassessments.

Post-Construction Storm Water Performance Standards: this General Permit specifies runoff reduction requirements for all sites not covered by a Phase I or Phase II MS4 NPDES permit, to avoid, minimize and/or mitigate post-construction storm water runoff impacts.

Rain Event Action Plan: this General Permit requires certain sites to develop and implement a Rain Event Action Plan (REAP) that must be designed to protect all exposed portions of the site within 48 hours prior to any likely precipitation event.

Annual Reporting: this General Permit requires all projects that are enrolled for more than one continuous three-month period to submit information and annually certify that their site is in compliance with these requirements. The primary purpose of this requirement is to provide information needed for overall program evaluation and public information.

Certification/Training Requirements for Key Project Personnel: this General Permit requires that key personnel (e.g., SWPPP preparers, inspectors, etc.) have specific training or certifications to ensure their level of knowledge and skills are adequate to ensure their ability to design and evaluate project specifications that will comply with General Permit requirements.

Linear Underground/Overhead Projects: this General Permit includes requirements for all Linear Underground/Overhead Projects (LUPs).

II. RATIONALE

A. General Permit Approach

A general permit for construction activities is an appropriate permitting approach for the following reasons:

1. A general permit is an efficient method to establish the essential regulatory requirements for a broad range of construction activities under differing site conditions;
2. A general permit is the most efficient method to handle the large number of construction storm water permit applications;
3. The application process for coverage under a general permit is far less onerous than that for individual permit and hence more cost effective;
4. A general permit is consistent with USEPA's four-tier permitting strategy, the purpose of which is to use the flexibility provided by the CWA in designing a workable and efficient permitting system; and
5. A general permit is designed to provide coverage for a group of related facilities or operations of a specific industry type or group of industries. It is appropriate when the discharge characteristics are sufficiently similar, and a standard set of permit requirements can effectively provide environmental protection and comply with water quality standards for discharges. In most cases, the general permit will provide sufficient and appropriate management requirements to protect the quality of receiving waters from discharges of storm water from construction sites.

There may be instances where a general permit is not appropriate for a specific construction project. A Regional Water Board may require any discharger otherwise covered under the General Permit to apply for and obtain an Individual Permit or apply for coverage under a more specific General Permit. The Regional Water Board must determine that this General Permit does not provide adequate assurance that water quality will be protected, or that there is a site-specific reason why an individual permit should be required.

B. Construction Activities Covered

1. Construction activity subject to this General Permit:

Any construction or demolition activity, including, but not limited to, clearing, grading, grubbing, or excavation, or any other activity that results in a land disturbance of equal to or greater than one acre.

Construction activity that results in land surface disturbances of less than one acre if the construction activity is part of a larger common plan of development or sale of one or more acres of disturbed land surface.

Construction activity related to residential, commercial, or industrial development on lands currently used for agriculture including, but not limited to, the construction of buildings related to agriculture that are considered industrial pursuant to USEPA regulations, such as dairy barns or food processing facilities.

Construction activity associated with LUPs including, but not limited to, those activities necessary for the installation of underground and overhead linear facilities (e.g., conduits, substructures, pipelines, towers, poles, cables, wires, connectors, switching, regulating and transforming equipment and associated ancillary facilities) and include, but are not limited to, underground utility mark-out, potholing, concrete

and asphalt cutting and removal, trenching, excavation, boring and drilling, access road and pole/tower pad and cable/wire pull station, substation construction, substructure installation, construction of tower footings and/or foundations, pole and tower installations, pipeline installations, welding, concrete and/or pavement repair or replacement, and stockpile/borrow locations.

Discharges of sediment from construction activities associated with oil and gas exploration, production, processing, or treatment operations or transmission facilities.³

Storm water discharges from dredge spoil placement that occur outside of U.S. Army Corps of Engineers jurisdiction⁴ (upland sites) and that disturb one or more acres of land surface from construction activity are covered by this General Permit. Construction projects that intend to disturb one or more acres of land within the jurisdictional boundaries of a CWA § 404 permit should contact the appropriate Regional Water Board to determine whether this permit applies to the project.

2. Linear Underground/Overhead Projects (LUPs) subject to this General Permit:

Underground/overhead facilities typically constructed as LUPs include, but are not limited to, any conveyance, pipe, or pipeline for the transportation of any gaseous, liquid (including water, wastewater for domestic municipal services), liquescent, or slurry substance; any cable line or wire for the transmission of electrical energy; any cable line or wire for communications (e.g., telephone, telegraph, radio or television messages); and associated ancillary facilities. Construction activities associated with LUPs include, but are not limited to, those activities necessary for the installation of underground and overhead linear facilities (e.g., conduits, substructures, pipelines, towers, poles, cables, wires, connectors, switching, regulating and transforming equipment and associated ancillary facilities) and include, but are not limited to, underground utility mark-out, potholing, concrete and asphalt cutting and removal, trenching, excavation, boring and drilling, access road and pole/tower pad and cable/wire pull station, substation construction, substructure installation, construction of tower footings and/or foundations, pole and tower installations, pipeline installations, welding, concrete and/or pavement repair or replacement, and stockpile/borrow locations.

Water Quality Order 2003-0007-DWQ regulated construction activities associated with small LUPs that resulted in land disturbances greater than one acre, but less than five acres. These projects were considered non-traditional construction projects. Attachment A of this Order now regulates all construction activities from LUPs resulting in land disturbances greater than one acre.

3. Common Plan of Development or Sale

USEPA regulations include the term “common plan of development or sale” to ensure that acreage within a common project does not artificially escape the permit requirements because construction activities are phased, split among smaller parcels, or completed by different owners/developers. In the absence of an

³ Pursuant to the Ninth Circuit Court of Appeals' decision in *NRDC v. EPA* (9th Cir. 2008) 526 F.3d 591, and subsequent denial of the USEPA's petition for reconsideration in November 2008, oil and gas construction activities discharging storm water contaminated only with sediment are no longer exempt from the NPDES program.

⁴ A construction site that includes a dredge and/or fill discharge to any water of the United States (e.g., wetland, channel, pond, or marine water) requires a CWA Section 404 permit from the U.S. Army Corps of Engineers and a CWA Section 401 Water Quality Certification from the Regional Water Board or State Water Board.

exact definition of “common plan of development or sale,” the State Water Board is required to exercise its regulatory discretion in providing a common sense interpretation of the term as it applies to construction projects and permit coverage. An overbroad interpretation of the term would render meaningless the clear “one acre” federal permitting threshold and would potentially trigger permitting of almost any construction activity that occurs within an area that had previously received area-wide utility or road improvements.

Construction projects generally receive grading and/or building permits (Local Permits) from local authorities prior to initiating construction activity. These Local Permits spell out the scope of the project, the parcels involved, the type of construction approved, etc. Referring to the Local Permit helps define “common plan of development or sale.” In cases such as tract home development, a Local Permit will include all phases of the construction project including rough grading, utility and road installation, and vertical construction. All construction activities approved in the Local Permit are part of the common plan and must remain under the General Permit until construction is completed. For custom home construction, Local Permits typically only approve vertical construction as the rough grading, utilities, and road improvements were already independently completed under the a previous Local Permit. In the case of a custom home site, the homeowner must submit plans and obtain a distinct and separate Local Permit from the local authority in order to proceed. It is not the intent of the State Water Board to require permitting for an individual homeowner building a custom home on a private lot of less than one acre if it is subject to a separate Local Permit. Similarly, the installation of a swimming pool, deck, or landscaping that disturbs less than one acre that was not part of any previous Local Permit are not required to be permitted.

The following are several examples of construction activity of less than one acre that would require permit coverage:

- a. A landowner receives a building permit(s) to build tract homes on a 100-acre site split into 200 one-third acre parcels, (the remaining acreage consists of streets and parkways) which are sold to individual homeowners as they are completed. The landowner completes and sells all the parcels except for two. Although the remaining two parcels combined are less than one acre, the landowner must continue permit coverage for the two parcels.
- b. One of the parcels discussed above is sold to another owner who intends to complete the construction as already approved in the Local Permit. The new landowner must file Permit Registration Documents (PRDs) to complete the construction even if the new landowner is required to obtain a separate Local Permit.
- c. Landowner in (1) above purchases 50 additional one half-acre parcels adjacent to the original 200-acre project. The landowner seeks a Local Permit (or amendment to existing Local permit) to build on 20 parcels while leaving the remaining 30 parcels for future development. The landowner must amend PRDs to include the 20 parcels 14 days prior to commencement of construction activity on those parcels.

C. Construction Activities Not Covered

1. Traditional Construction Projects Not Covered

This General Permit does not apply to the following construction activity:

- a. Routine maintenance to maintain original line and grade, hydraulic capacity, or original purpose of the facility.

- b. Disturbances to land surfaces solely related to agricultural operations such as disking, harrowing, terracing and leveling, and soil preparation.
- c. Discharges of storm water from areas on tribal lands; construction on tribal lands is regulated by a federal permit.
- d. Discharges of storm water within the Lake Tahoe Hydrologic Unit. The Lahontan Regional Water Board has adopted its own permit to regulate storm water discharges from construction activity in the Lake Tahoe Hydrologic Unit (Regional Water Board 6SLT). Owners of construction projects in this watershed must apply for the Lahontan Regional Water Board permit rather than the statewide Construction General Permit. Construction projects within the Lahontan region must also comply with the Lahontan Region Project Guideline for Erosion Control (R6T-2005-0007 Section), which can be found at http://www.waterboards.ca.gov/lahontan/Adopted_Orders/2005/r6t_2005_0007.pdf
- e. Construction activity that disturbs less than one acre of land surface, unless part of a larger common plan of development or the sale of one or more acres of disturbed land surface.
- f. Construction activity covered by an individual NPDES Permit for storm water discharges.
- g. Landfill construction activity that is subject to the Industrial General Permit.
- h. Construction activity that discharges to Combined Sewer Systems.
- i. Conveyances that discharge storm water runoff combined with municipal sewage.
- j. Discharges of storm water identified in CWA § 402(l)(2), 33 U.S.C. § 1342(l)(2).

2. Linear Projects Not Covered

- a. LUP construction activity does not include linear routine maintenance projects. Routine maintenance projects are projects associated with operations and maintenance activities that are conducted on existing lines and facilities and within existing right-of-way, easements, franchise agreements, or other legally binding agreements of the discharger. Routine maintenance projects include, but are not limited to projects that are conducted to:
 - i. Maintain the original purpose of the facility or hydraulic capacity.
 - ii. Update existing lines⁵ and facilities to comply with applicable codes, standards, and regulations regardless if such projects result in increased capacity.
 - iii. Repairing leaks.

⁵Update existing lines includes replacing existing lines with new materials or pipes.

Routine maintenance does not include construction of new⁶ lines or facilities resulting from compliance with applicable codes, standards, and regulations.

Routine maintenance projects do not include those areas of maintenance projects that are outside of an existing right-of-way, franchise, easements, or agreements. When a project must secure new areas, those areas may be subject to this General Permit based on the area of disturbed land outside the original right-of-way, easement, or agreement.

- b. LUP construction activity does not include field activities associated with the planning and design of a project (e.g., activities associated with route selection).
- c. Tie-ins conducted immediately adjacent to “energized” or “pressurized” facilities by the discharger are not considered construction activities where all other LUP construction activities associated with the tie-in are covered by an NOI and SWPPP of a third party or municipal agency.

3. EPA’s Small Construction Rainfall Erosivity Waiver

EPA’s Storm Water Phase II Final Rule provides the option for a Small Construction Rainfall Erosivity Waiver. This waiver applies to small construction sites between 1 and 5 acres, and allows permitting authorities to waive those sites that do not have adverse water quality impacts.

Dischargers eligible for this waiver are exempt from Construction General Permit Coverage. In order to obtain the waiver, the discharger must certify to the State Water Board that small construction activity will occur only when the rainfall erosivity factor is less than 5 (“R” in the Revised Universal Soil Loss Equation). The period of construction activity begins at initial earth disturbance and ends with final stabilization. Where vegetation will be used for final stabilization, the date of installation of a practice that provides interim non-vegetative stabilization can be used for the end of the construction period. The operator must agree (as a condition waiver eligibility) to periodically inspect and properly maintain the area until the criteria for final stabilization as defined in the General Permit have been met. If use of this interim stabilization eligibility condition was relied on to qualify for the waiver, signature on the waiver with a certification statement constitutes acceptance of and commitment to complete the final stabilization process. The discharger must submit a waiver certification to the State Board prior to commencing construction activities.

USEPA funded a cooperative agreement with Texas A&M University to develop an online rainfall erosivity calculator. Dischargers can access the calculator from EPA’s website at: www.epa.gov/npdes/stormwater/cgp. Use of the calculator allows the discharger to determine potential eligibility for the rainfall erosivity waiver. It may also be useful in determining the time periods during which construction activity could be waived from permit coverage.

⁶New lines are those that are not associated with existing facilities and are not part of a project to update or replace existing lines.

D. Obtaining and Terminating Permit Coverage

The appropriate Legally Responsible Person (LRP) must obtain coverage under this General Permit. To obtain coverage, the LRP or the LRP's Approved Signatory must file Permit Registration Documents (PRDs) prior to the commencement of construction activity. Failure to obtain coverage under this General Permit for storm water discharges to waters of the United States is a violation of the CWA and the California Water Code.

To obtain coverage under this General Permit, LRPs must electronically file the PRDs, which include a Notice of Intent (NOI), Storm Water Pollution Prevention Plan (SWPPP), and other documents required by this General Permit, and mail the appropriate permit fee to the State Water Board. It is expected that as the storm water program develops, the Regional Water Boards may issue General Permits or Individual Permits that contain more specific permit provisions. When this occurs, this General Permit will no longer regulate those dischargers that obtain coverage under Individual Permits.

Any information provided to the Regional Water Board shall comply with the Homeland Security Act and any other federal law that concerns security in the United States; any information that does not comply should not be submitted.

The application requirements of the General Permit establish a mechanism to clearly identify the responsible parties, locations, and scope of operations of dischargers covered by the General Permit and to document the discharger's knowledge of the General Permit's requirements.

This General Permit provides a grandfathering exception to existing dischargers subject to Water Quality Order No. 99-08-DWQ. Construction projects covered under Water Quality Order No. 99-08-DWQ shall obtain permit coverage at Risk Level 1. LUP projects covered under Water Quality Order No. 2003-0007-DWQ shall obtain permit coverage at LUP Type 1. The Regional Water Boards have the authority to require Risk Determination to be performed on projects currently covered under Water Quality Order No. 99-08-DWQ and 2003-0007-DWQ where they deem necessary.

LRPs must file a Notice of Termination (NOT) with the Regional Water Board when construction is complete and final stabilization has been reached or ownership has been transferred. The discharger must certify that all State and local requirements have been met in accordance with this General Permit. In order for construction to be found complete, the discharger must install post-construction storm water management measures and establish a long-term maintenance plan. This requirement is intended to ensure that the post-construction conditions at the project site do not cause or contribute to direct or indirect water quality impacts (i.e., pollution and/or hydromodification) upstream and downstream. Specifically, the discharger must demonstrate compliance with the post-construction standards set forth in this General Permit (Section XIII). The discharger is responsible for all compliance issues including all annual fees until the NOT has been filed and approved by the local Regional Water Board.

E. Discharge Prohibitions

This General Permit authorizes the discharge of storm water to surface waters from construction activities that result in the disturbance of one or more acres of land, provided that the discharger satisfies all permit conditions set forth in the Order. This General Permit prohibits the discharge of pollutants other than storm water and non-storm water discharges authorized by this General Permit or another NPDES permit. This General Permit also prohibits all discharges which contain a hazardous substance in excess of reportable quantities established in 40 C.F.R. §§ 117.3 and 302.4, unless a separate NPDES Permit has been issued to regulate those discharges. In addition, this General Permit incorporates discharge prohibitions contained in water quality control plans, as implemented by the nine Regional Water Boards. Discharges to Areas of Special Biological Significance (ASBS) are prohibited unless covered by an exception that the State Water Board has approved.

Non-storm water discharges include a wide variety of sources, including improper dumping, spills, or leakage from storage tanks or transfer areas. Non-storm water discharges may contribute significant pollutant loads to receiving waters. Measures to control spills, leakage, and dumping, and to prevent illicit connections during construction must be addressed through structural as well as non-structural BMPs. The State Water Board recognizes, however, that certain non-storm water discharges may be necessary for the completion of construction projects. Authorized non-storm water discharges may include those from de-chlorinated potable water sources such as: fire hydrant flushing, irrigation of vegetative erosion control measures, pipe flushing and testing, water to control dust, uncontaminated ground water dewatering, and other discharges not subject to a separate general NPDES permit adopted by a region. Therefore this General Permit authorizes such discharges provided they meet the following conditions.

These authorized non-storm water discharges must:

1. be infeasible to eliminate;
2. comply with BMPs as described in the SWPPP;
3. filter or treat, using appropriate technology, all dewatering discharges from sedimentation basins;
4. meet the NALs for pH and turbidity; and
5. not cause or contribute to a violation of water quality standards.

Additionally, authorized non-storm water discharges must not be used to clean up failed or inadequate construction or post-construction BMPs designed to keep materials onsite. Authorized non-storm water dewatering discharges may require a permit because some Regional Water Boards have adopted General Permits for dewatering discharges.

This General Permit prohibits the discharge of storm water that causes or threatens to cause pollution, contamination, or nuisance.

F. Effluent Standards for All Types of Discharges

1. Technology-Based Effluent Limitations

Permits for storm water discharges associated with construction activity must meet all applicable provisions of Sections 301 and 402 of the CWA. These provisions require controls of pollutant discharges that utilize best available technology economically achievable (BAT) for toxic pollutants and non conventional pollutants and best conventional pollutant control technology (BCT) for conventional pollutants. Additionally, these provisions require controls of pollutant discharges to reduce pollutants and any more stringent controls necessary to meet water quality standards. The USEPA has already established such limitations, known as effluent limitation guidelines (ELGs), for some industrial categories. This is not the case with construction discharges. In instances where there are no ELGs the permit writer is to use best professional judgment (BPJ) to establish requirements that the discharger must meet using BAT/BCT technology. This General Permit contains only narrative effluent limitations and does not contain numeric effluent limitations, except for Active Treatment Systems (ATS).

Order No. 2009-0009-DWQ, as originally adopted by the State Water Board on September 2, 2009, contained numeric effluent limitations for pH (within the range of 6.0 and 9.0 pH units) and turbidity (500 NTU) that applied only to Risk Level 3 and LUP Type 3 construction sites. The State Water Board adopted the numeric effluent limitations as technology-based effluent limitations based upon its best professional judgment. The California Building Industry Association, the Building Industry Legal Defense

Foundation, and the California Business Properties Association (petitioners) challenged Order No. 2009-0009-DWQ in *California Building Industry Association et al. v. State Water Resources Control Board*. On December 27, 2011, the Superior Court issued a judgment and writ of mandamus. The Superior Court ruled in favor of the State Water Board on almost all of the issues the petitioners raised, but the Superior Court invalidated the numeric effluent limitations for pH and turbidity for Risk Level 3 and LUP Type 3 sites because it determined that the State Water Board did not have sufficient BMP performance data to support those numeric effluent limitations. Therefore, the Superior Court concluded that the State Water Board did not comply with the federal regulations that apply to the use of best professional judgment. In invalidating the numeric effluent limitations, the Superior Court also suspended two ancillary requirements (a compliance storm event provision and receiving water monitoring at Risk Level 3 and LUP Type 3 sites that violated the numeric effluent limitations) that related solely to the invalidated numeric effluent limitations.

As a result of the Superior Court's writ of mandamus, this Order no longer contains numeric effluent limitations for pH and turbidity, except for ATS. In addition, as a result of the Superior Court's writ of mandamus, the receiving water monitoring requirements for Risk Level 3 and LUP Type 3 sites were suspended until the State Water Board amended this Order to restore the receiving water monitoring requirements. As amended, this Order now requires Risk Level 3 and LUP Type 3 Dischargers with direct discharges to surface waters to conduct receiving water monitoring whenever their effluent exceeds specified receiving water monitoring triggers. The receiving water monitoring triggers were established at the same levels as the previous numeric effluent limitations (effluent pH outside the range of 6.0 and 9.0 pH units or turbidity exceeding 500 NTU). In restoring the receiving water monitoring requirements, the State Water Board determined that it was appropriate to require receiving water monitoring for these types of sites with direct discharges to surface waters that exceeded the receiving water monitoring triggers under any storm event scenarios, because these sites represent the highest threat to receiving water quality. An exceedance of a receiving water monitoring trigger does not constitute a violation of this General Permit. These receiving water monitoring requirements take effect on the effective date of the amendment to this Order.

BAT/BCT technologies not only include passive systems such as conventional runoff and sediment control, but also treatment systems such as coagulation/flocculation using sand filtration, when appropriate. Such technologies allow for effective treatment of soil particles less 0.02 mm (medium silt) in diameter. The discharger must install structural-controls, as necessary, such as erosion and sediment controls that meet BAT and BCT to achieve compliance with water quality standards. The narrative effluent limitations constitute compliance with the requirements of the CWA.

Because the permit is an NPDES permit, there is no legal requirement to address the factors set forth in Water Code sections 13241 and 13263, unless the permit is more stringent than what federal law requires. (See *City of Burbank v. State Water Resources Control Bd.* (2005) 35 Cal.4th 613, 618, 627.) None of the requirements in this permit are more stringent than the minimum federal requirements, which include technology-based requirements achieving BAT/BCT and strict compliance with water quality standards. The inclusion of numeric effluent limitations (NELs) in the permit for Active Treatment Systems does not cause the permit to be more stringent than current federal law. NELs and best management practices are simply two different methods of achieving the same federal requirement: strict compliance with state water quality standards. Federal law authorizes both narrative and numeric effluent limitations to meet state water quality standards. The use of NELs to achieve compliance with water quality standards is not a more stringent requirement than the use of BMPs. (State Water Board Order No. WQ 2006-0012 (*Boeing*)). Accordingly, the State Water Board does not need to take into account the factors in Water Code sections 13241 and 13263.

The State Water Board has concluded that the establishment of BAT/BCT will not create or aggravate other environmental problems through increases in air pollution, solid waste generation, or energy consumption.—While there may be a slight increase in non-water quality impacts due to the implementation of additional monitoring or the construction of additional BMPs, these impacts will be negligible in comparison with the construction activities taking place on site and would be justified by the water quality benefits associated with compliance.

pH Receiving Water Monitoring Trigger

Given the potential contaminants, the minimum standard method for control of pH in runoff requires the use of preventive measures such as avoiding concrete pours during rainy weather, covering concrete and directing flow away from fresh concrete if a pour occurs during rain, covering scrap drywall and stucco materials when stored outside and potentially exposed to rain, and other housekeeping measures. If necessary, pH-impaired storm water from construction sites can be treated in a filter or settling pond or basin, with additional natural or chemical treatment required to meet pH limits set forth in this permit. The basin or pond acts as a collection point and holds storm water for a sufficient period for the contaminants to be settled out, either naturally or artificially, and allows any additional treatment to take place. The State Water Board considers these techniques to be equivalent to BCT. In determining the pH concentration trigger for discharges, the State Water Board used BPJ to set these limitations.

The chosen trigger was established by calculating three standard deviations above and below the mean pH of runoff from highway construction sites⁷ in California. Proper implementation of BMPs should result in discharges that are within the range of 6.0 to 9.0 pH Units.

Turbidity Receiving Water Monitoring Trigger

The Turbidity receiving water monitoring trigger of 500 NTU is a technology-based trigger and was developed using three different analyses aimed at finding the appropriate threshold to set the technology-based limit to ensure environmental protection, effluent quality and cost-effectiveness. The analyses fell into three, main types: (1) an ecoregion-specific dataset developed by Simon et. al. (2004)⁸; (2) Statewide Regional Water Quality Control Board enforcement data; and (3) published, peer-reviewed studies and reports on in-situ performance of best management practices in terms of erosion and sediment control on active construction sites.

A 1:3 relationship between turbidity (expressed as NTU) and suspended sediment concentration (expressed as mg/L) is assumed based on a review of suspended sediment and turbidity data from three gages used in the USGS National Water Quality Assessment Program:

USGS 11074000 SANTA ANA R BL PRADO DAM CA
USGS 11447650 SACRAMENTO R A FREEPORT CA
USGS 11303500 SAN JOAQUIN R NR VERNALIS CA

The receiving water monitoring trigger represents staff determination that the trigger value is the most practicable based on available data. The turbidity receiving water monitoring trigger represents a bridge between the narrative effluent limitations and receiving water limitations. To support this receiving water monitoring trigger, State Water Board staff analyzed construction site discharge information (monitoring data, estimates) and receiving water monitoring information.

Since the turbidity receiving water monitoring trigger represents an appropriate threshold level expected at a site, compliance with this value does not necessarily represent compliance with either the narrative effluent limitations (as enforced through the BAT/BCT standard) or the receiving water limitations. In the San Diego region, some inland surface waters have a receiving water objective for turbidity equal to 20 NTU. Obviously a discharge up to, but not exceeding, the turbidity receiving water monitoring trigger of

⁷ Caltrans Construction Sites Runoff Characterization Study, 2002. Available at: <http://www.dot.ca.gov/hq/env/stormwater/pdf/CTSW-RT-02-055.pdf>.

500 NTU may still cause or contribute to the exceedance of the 20 NTU standard. Most of the waters of the State are protected by turbidity objectives based on background conditions.

Table 1 - Regional Water Board Basin Plans, Water Quality Objectives for Turbidity

REGIONAL WATER BOARD	WQ Objective	Background/Natural Turbidity	Maximum Increase
1	Based on background	All levels	20%
2	Based on background	> 50 NTU	10%
3	Based on background	0-50 JTU 50-100 JTU > 100 JTU	20% 10 NTU 10%
4	Based on background	0-50 NTU > 50 NTU	20% 10%
5	Based on background	0-5 NTU 5-50 NTU 50-100 NTU >100 NTU	1 NTU 20% 10 NTU 10%
6	Based on background	All levels	10%
7	Based on background	N/A	N/A
8	Based on background	0-50 NTU 50-100 NTU >100 NTU	20% 10 NTU 10%
9	Inland Surface Waters, 20 NTU All others, based on background	 0-50 NTU 50-100 NTU >100 NTU	 20% 10 NTU 10%

Table 2 shows the suspended sediment concentrations at the 1.5 year flow recurrence interval for the 12 ecoregions in California from Simon et. al (2004).

Table 2 - Results of Ecoregion Analysis

Ecoregion	Percent of California Land Area	Median Suspended Sediment Concentration (mg/L)
1	9.1	874
4	0.2	120
5	8.8	35.6
6	20.7	1530
7	7.7	122
8	3.0	47.4
9	9.4	284
13	5.2	143
14	21.7	5150
78	8.1	581
80	2.4	199
81	3.7	503
Area-weighted average		1633

If a 1:3 relationship between turbidity and suspended sediment is assumed, the median turbidity is 544 NTU.

The following table is composed of turbidity readings measured in NTUs from administrative civil liability (ACL) actions for construction sites from 2003 - 2009. This data was derived from the complete listing of construction-related ACLs for the six year period. All ACLs were reviewed and those that included turbidimeter readings at the point of storm water discharge were selected for this dataset.

Table 3 – ACL Sampling Data taken by Regional Water Board Staff

WDID#	Region	Discharger	Turbidity (NTU)
5S34C331884	5S	Bradshaw Interceptor Section 6B	1800
5S05C325110	5S	Bridalwood Subdivision	1670
5S48C336297	5S	Cheyenne at Browns Valley	1629
5R32C314271	5R	Grizzly Ranch Construction	1400
6A090406008	6T	El Dorado County Department of Transportation, Angora Creek	97.4
5S03C346861	5S	TML Development, LLC	1600
6A31C325917	6T	Northstar Village	See Subdata Set

Subdata Set - Turbidity for point of storm water runoff discharge at Northstar Village

Date	Turbidity (NTU)	Location
10/5/2006	900	Middle Martis Creek
11/2/2006	190	Middle Martis Creek
01/04/2007	36	West Fork, West Martis Creek
02/08/2007	180	Middle Martis Creek
02/09/2007	130	Middle Martis Creek
02/09/2007	290	Middle Martis Creek
02/09/2007	100	West Fork, West Martis Creek
02/10/2007	28	Middle Martis Creek
02/10/2007	23	Middle Martis Creek
02/10/2007	32	Middle Martis Creek
02/10/2007	12	Middle Martis Creek
02/10/2007	60	West Fork, West Martis Creek
02/10/2007	34	West Fork, West Martis Creek

A 95% confidence interval for mean turbidity in an ACL order was constructed. The data set used was a small sample size, so the 500 NTU (the value derived as the receiving water monitoring trigger for this General Permit) needed to be verified as a possible population mean. In this case, the population refers to a hypothetical population of turbidity measurements of which our sample of 20 represents. A t-distribution was assumed due to the small sample size:

<p>Mean: 512.23 NTU Standard Deviation: 686.85 Margin of Error: 321.45 Confidence Interval: 190.78 NTU (Low) 833.68 NTU (High)</p>
--

Based on a constructed 95% confidence interval, an ACL order turbidity measurement will be between 190.78 – 833.68 NTU. 500 NTU falls within this range. Using the same data set, a small-sample hypothesis test was also performed to test if the ACL turbidity data set contains enough information to cast doubt on choosing a 500 NTU as a mean. 500 NTU was again chosen due to its proposed use as an acceptable value. The test was carried out using a 95% confidence interval. Results indicated that the ACL turbidity data set *does not* contain significant sample evidence to reject the claim of 500 NTU as an acceptable mean for the ACL turbidity population.

There are not many published, peer-reviewed studies and reports on in-situ performance of best management practices in terms of erosion and sediment control on active construction sites. The most often cited study is a report titled, “Improving the Cost Effectiveness of Highway Construction Site Erosion and Pollution Control” (Horner, Guedry, and Kortenof 1990, <http://www.wsdot.wa.gov/Research/Reports/200/200.1.htm>). In a comment letter summarizing this report sent to the State Water Board, the primary author, Dr. Horner, states:

“The most effective erosion control product was wood fiber mulch applied at two different rates along with a bonding agent and grass seed in sufficient time before the tests to achieve germination. Plots treated in this way reduced influent turbidity by more than 97 percent and discharged effluent exhibiting mean and maximum turbidity values of 21 and 73 NTU, respectively. Some other mulch and blanket materials performed nearly as well. These tests demonstrated the control ability of widely available BMPs over a very broad range of erosion potential.”

Other technologies studied in this report produced effluent quality at or near 100 NTU. It is the BPJ of the State Water Board staff that erosion control, while preferred, is not always an option on construction sites and that technology performance in a controlled study showing effluent quality directly leaving a BMP is always easier and cheaper to control than effluent being discharged from the project (edge of property, etc.). As a result, it is the BPJ of the State Water Board staff that it is not cost effective or feasible, at this time, for all risk level and type 3 sites in California to achieve effluent discharges with turbidity values that are less than 100 NTU.

To summarize, the analysis showed that: (1) results of the Simon et. al dataset reveals turbidity values in background receiving water in California’s ecoregions range from 16 NTU to 1716 NTU (with a mean of 544 NTU); (2) based on a constructed 95% confidence interval, construction sites will be subject to administrative civil liability (ACL) when their turbidity measurement falls between 190.78 – 833.68 NTU; and (3) sites with highly controlled discharges employing and maintaining good erosion control practices can discharge effluent from the BMP with turbidity values less than 100 NTU. State Water Board staff has determined, using its BPJ, that it is most cost effective to set the receiving water monitoring trigger for turbidity at 500 NTU.

i. Compliance Storm Event

While this General Permit no longer contains “compliance storm event” exceptions from technology-based NELs, the “compliance storm event” exception from the ATS NELs remain in effect. See Section K of this Fact Sheet, and Attachment F of this General Permit for more information.

a. TMDLs and Waste Load Allocations

Dischargers located within the watershed of a CWA § 303(d) impaired water body, for which a TMDL for sediment has been adopted by the Regional Water Board or USEPA, must comply with the approved TMDL if it identifies “construction activity” or land disturbance as a source of sediment. If it does, the

TMDL should include a specific waste load allocation for this activity/source. The discharger, in this case, may be required by a separate Regional Water Board order to implement additional BMPs, conduct additional monitoring activities, and/or comply with an applicable waste load allocation and implementation schedule. If a specific waste load allocation has been established that would apply to a specific discharge, the Regional Water Board may adopt an order requiring specific implementation actions necessary to meet that allocation. In the instance where an approved TMDL has specified a general waste load allocation to construction storm water discharges, but no specific requirements for construction sites have been identified in the TMDL, dischargers must consult with the state TMDL authority⁹ to confirm that adherence to a SWPPP that meets the requirements of the General Permit will be consistent with the approved TMDL.

2. Determining Compliance with Effluent Standards

a. Technology-Based Numeric Action Levels (NALs)

This General Permit contains technology-based NALs for pH and turbidity, and requirements for effluent monitoring at all Risk level 2 & 3, and LUP Type 2 & 3 sites. Numeric action levels are essentially numeric benchmark values for certain parameters that, if exceeded in effluent sampling, trigger the discharger to take actions. Exceedance of an NAL does not itself constitute a violation of the General Permit. If the discharger fails to take the corrective action required by the General Permit, though, that may constitute a violation.

The primary purpose of NALs is to assist dischargers in evaluating the effectiveness of their on-site measures. Construction sites need to employ many different systems that must work together to achieve compliance with the permit's requirements. The NALs chosen should indicate whether the systems are working as intended.

Another purpose of NALs is to provide information regarding construction activities and water quality impacts. This data will provide the State and Regional Water Boards and the rest of the storm water community with more information about levels and types of pollutants present in runoff and how effective the dischargers BMPs are at reducing pollutants in effluent. The State Water Board also hopes to learn more about the linkage between effluent and receiving water quality. In addition, these requirements will provide information on the mechanics needed to establish compliance monitoring programs at construction sites in future permit deliberations.

i. pH

The chosen limits were established by calculating one standard deviation above and below the mean pH of runoff from highway construction sites¹⁰ in California. Proper implementation of BMPs should result in discharges that are within the range of 6.5 to 8.5 pH Units.

⁹ <http://www.waterboards.ca.gov/tmdl/tmdl.html>.

¹⁰ Caltrans Construction Sites Runoff Characterization Study, 2002. Available at: <http://www.dot.ca.gov/hq/env/stormwater/pdf/CTSW-RT-02-055.pdf>.

The Caltrans study included 33 highway construction sites throughout California over a period of four years, which included 120 storm events. All of these sites had BMPs in place that would be generally implemented at all types of construction sites in California.

ii. *Turbidity*

BPJ was used to develop an NAL that can be used as a learning tool to help dischargers improve their site controls, and to provide meaningful information on the effectiveness of storm water controls. A statewide turbidity NAL has been set at 250 NTU.

G. Receiving Water Limitations

Construction-related activities that cause or contribute to an exceedance of water quality standards must be addressed. The dynamic nature of construction activity gives the discharger the ability to quickly identify and monitor the source of the exceedances. This is because when storm water mobilizes sediment, it provides visual cues as to where corrective actions should take place and how effective they are once implemented.

This General Permit requires that storm water discharges and authorized non-storm water discharges must not contain pollutants that cause or contribute to an exceedance of any applicable water quality objective or water quality standards. The monitoring requirements in this General Permit for sampling and analysis procedures will help determine whether BMPs installed and maintained are preventing pollutants in discharges from the construction site that may cause or contribute to an exceedance of water quality standards.

Water quality standards consist of designated beneficial uses of surface waters and the adoption of ambient criteria necessary to protect those uses. When adopted by the State Water Board or a Regional Water Board, the ambient criteria are termed “water quality objectives.” If storm water runoff from construction sites contains pollutants, there is a risk that those pollutants could enter surface waters and cause or contribute to an exceedance of water quality standards. For that reason, dischargers should be aware of the applicable water quality standards in their receiving waters. (The best method to ensure compliance with receiving water limitations is to implement BMPs that prevent pollutants from contact with storm water or from leaving the construction site in runoff.)

In California, water quality standards are published in the Basin Plans adopted by each Regional Water Board, the California Toxics Rule (CTR), the National Toxics Rule (NTR), and the Ocean Plan.

Dischargers can determine the applicable water quality standards by contacting Regional Water Board staff or by consulting one of the following sources. The actual Basin Plans that contain the water quality standards can be viewed at the website of the appropriate Regional Water Board. (<http://www.waterboards.ca.gov/regions.html>), the State Water Board site for statewide plans (<http://www.waterboards.ca.gov/plnspols/index.html>), or the USEPA regulations for the NTR and CTR (40 C.F.R. §§ 131.36-38). Basin Plans and statewide plans are also available by mail from the appropriate Regional Water Board or the State Water Board. The USEPA regulations are available at <http://www.epa.gov/>. Additional information concerning water quality standards can be accessed through http://www.waterboards.ca.gov/stormwtr/gen_const.html.

H. Training Qualifications and Requirements

The Blue Ribbon Panel (BRP) made the following observation about the lack of industry-specific training requirements:

“Currently, there is no required training or certification program for contractors, preparers of soil erosion and sediment control Storm Water Pollution Prevention Plans, or field inspectors.”

Order 99-08-DWQ required that all dischargers train their employees on how to comply with the permit, but it did not specify a curriculum or certification program. This has resulted in inconsistent implementation by all affected parties - the dischargers, the local governments where the construction activity occurs, and the regulators required to enforce 99-08-DWQ. This General Permit requires Qualified SWPPP Developers and practitioners to obtain appropriate training, and makes this curriculum mandatory two years after adoption, to allow time for course completion. The State and Regional Water Board are working with many stakeholders to develop the curriculum and mechanisms needed to develop and deliver the courses.

To ensure that the preparation, implementation, and oversight of the SWPPP is sufficient for effective pollution prevention, the Qualified SWPPP Developer and Qualified SWPPP Practitioners responsible for creating, revising, overseeing, and implementing the SWPPP must attend a State Water Board-sponsored or approved Qualified SWPPP Developer and Qualified SWPPP Practitioner training course.

I. Sampling, Monitoring, Reporting and Record Keeping

1. Traditional Construction Monitoring Requirements

This General Permit requires visual monitoring at all sites, and effluent water quality at all Risk Level 2 & 3 sites. It requires receiving water monitoring at some Risk Level 3 sites. All sites are required to submit annual reports, which contain various types of information, depending on the site characteristics and events. A summary of the monitoring and reporting requirements is found in Table 4.

Table 4 - Required Monitoring Elements for Risk Levels

	Visual	Non-visible Pollutant	Effluent	Receiving Water
Risk Level 1			where applicable	not required
Risk Level 2			pH, turbidity	not required
Risk Level 3	three types required for all Risk Levels: non-storm water, pre-rain and post-rain	As needed for all Risk Levels (see below)	pH, turbidity	(if Receiving Water Monitoring Trigger exceeded) pH, turbidity and SSC. Bioassessment for sites 30 acres or larger.

a. Visual

All dischargers are required to conduct quarterly, non-storm water visual inspections. For these inspections, the discharger must visually observe each drainage area for the presence of (or indications of prior) unauthorized and authorized non-storm water discharges and their sources. For storm-related inspections, dischargers must visually observe storm water discharges at all discharge locations within two business days after a qualifying event. For this requirement, a qualifying rain event is one producing precipitation of ½ inch or more of discharge. Dischargers must conduct a post-storm event inspection to (1) identify whether BMPs were adequately designed, implemented, and effective, and (2) identify any additional BMPs necessary and revise the SWPPP accordingly. Dischargers must maintain on-site records of all visual observations, personnel performing the observations, observation dates, weather conditions, locations observed, and corrective actions taken in response to the observations.

b. Non-Visible Pollutant Monitoring

This General Permit requires that all dischargers develop a sampling and analysis strategy for monitoring pollutants that are not visually detectable in storm water. Monitoring for non-visible pollutants must be required at any construction site when the exposure of construction materials occurs and where a discharge can cause or contribute to an exceedance of a water quality objective.

Of significant concern for construction discharges are the pollutants found in materials used in large quantities at construction sites throughout California and exposed throughout the rainy season, such as cement, flyash, and other recycled materials or by-products of combustion. The water quality standards that apply to these materials will depend on their composition. Some of the more common storm water pollutants from construction activity are not CTR pollutants. Examples of non-visible pollutants include glyphosate (herbicides), diazinon and chlorpyrifos (pesticides), nutrients (fertilizers), and molybdenum (lubricants). The use of diazinon and chlorpyrifos is a common practice among landscaping professionals and may trigger sampling and analysis requirements if these materials come into contact with storm water. High pH values from cement and gypsum, high pH and SSC from wash waters, and chemical/fecal contamination from portable toilets, also are not CTR pollutants. Although some of these constituents do have numeric water quality objectives in individual Basin Plans, many do not and are subject only to narrative water quality standards (i.e. not causing toxicity). Dischargers are encouraged to discuss these issues with Regional Water Board staff and other storm water quality professionals.

The most effective way to avoid the sampling and analysis requirements, and to ensure permit compliance, is to avoid the exposure of construction materials to precipitation and storm water runoff. Materials that are not exposed do not have the potential to enter storm water runoff, and therefore receiving waters sampling is not required. Preventing contact between storm water and construction materials is one of the most important BMPs at any construction site.

Preventing or eliminating the exposure of pollutants at construction sites is not always possible. Some materials, such as soil amendments, are designed to be used in a manner that will result in exposure to storm water. In these cases, it is important to make sure that these materials are applied according to the manufacturer's instructions and at a time when they are unlikely to be washed away. Other construction materials can be exposed when storage, waste disposal or the application of the material is done in a manner not protective of water quality. For these situations, sampling is required unless there is capture and containment of all storm water that has been exposed. In cases where construction materials may be exposed to storm water, but the storm water is contained and is not allowed to run off the site, sampling will only be required when inspections show that the containment failed or is breached, resulting in potential exposure or discharge to receiving waters.

The discharger must develop a list of potential pollutants based on a review of potential sources, which will include construction materials soil amendments, soil treatments, and historic contamination at the site. The discharger must review existing environmental and real estate documentation to determine the potential for pollutants that could be present on the construction site as a result of past land use activities.

Good sources of information on previously existing pollution and past land uses include:

- i. Environmental Assessments;
- ii. Initial Studies;
- iii. Phase 1 Assessments prepared for property transfers; and
- iv. Environmental Impact Reports or Environmental Impact Statements prepared under the requirements of the National Environmental Policy Act or the California Environmental Quality Act.

In some instances, the results of soil chemical analyses may be available and can provide additional information on potential contamination.

The potential pollutant list must include all non-visible pollutants that are known or should be known to occur on the construction site including, but not limited to, materials that:

- i. are being used in construction activities;
- ii. are stored on the construction site;
- iii. were spilled during construction operations and not cleaned up;
- iv. were stored (or used) in a manner that created the potential for a release of the materials during past land use activities;
- v. were spilled during previous land use activities and not cleaned up; or
- vi. were applied to the soil as part of past land use activities.

C. Effluent Monitoring

Federal regulations¹¹ require effluent monitoring for discharges subject to NALs. Subsequently, all Risk Level 2 and 3 dischargers must perform sampling and analysis of effluent discharges to characterize discharges associated with construction activity from the entire area disturbed by the project. Dischargers must collect samples of stored or contained storm water that is discharged subsequent to a storm event producing precipitation of ½ inch or more at the time of discharge.

Table 5 - Storm Water Effluent Monitoring Requirements by Risk Level

	Frequency	Effluent Monitoring (Section E, below)
Risk Level 1	when applicable	non-visible pollutant parameters (if applicable)
Risk Level 2	Minimum of 3 samples per day during qualifying rain event characterizing discharges associated with construction activity from the entire project disturbed area.	pH, turbidity, and non-visible pollutant parameters (if applicable)
Risk Level 3	Minimum of 3 samples per day during qualifying rain event characterizing discharges associated with construction activity from the entire project disturbed area.	pH, turbidity, and non-visible pollutant parameters if applicable

Risk Level 1 dischargers must analyze samples for:

- i. any parameters indicating the presence of pollutants identified in the pollutant source assessment required in Attachment C contained in the General Permit.

¹¹ 40 C.F.R. § 122.44.

Risk Level 2 dischargers must analyze samples for:

- i. pH and turbidity;
- ii. any parameters indicating the presence of pollutants identified in the pollutant source assessment required in Attachment D contained in the General Permit, and
- iii. any additional parameters for which monitoring is required by the Regional Water Board.

Risk Level 3 dischargers must analyze samples for:

- i. pH, turbidity;
- ii. any parameters indicating the presence of pollutants identified in the pollutant source assessment required in Attachment E contained in the General Permit, and
- iii. any additional parameters for which monitoring is required by the Regional Water Board.

2. Linear Monitoring and Sampling Requirements

Attachment A, establishes minimum monitoring and reporting requirements for all LUPs. It establishes different monitoring requirements depending on project complexity and risk to water quality. The monitoring requirements for Type 1 LUPs are less than Type 2 & 3 projects because Type 1 projects have a lower potential to impact water quality.

A discharger shall prepare a monitoring program prior to the start of construction and immediately implement the program at the start of construction for LUPs. The monitoring program must be implemented at the appropriate level to protect water quality at all times throughout the life of the project.

a. Type 1 LUP Monitoring Requirements

A discharger must conduct daily visual inspections of Type 1 LUPs during working hours while construction activities are occurring. Inspections are to be conducted by qualified personnel and can be conducted in conjunction with other daily activities. Inspections will be conducted to ensure the BMPs are adequate, maintained, and in place at the end of the construction day. The discharger will revise the SWPPP, as appropriate, based on the results of the daily inspections. Inspections can be discontinued in non-active construction areas where soil disturbing activities have been completed and final stabilization has been achieved (e.g., trench has been paved, substructures have been installed, and successful final vegetative cover or other stabilization criteria have been met).

A discharger shall implement the monitoring program for inspecting Type 1 LUPs. This program requires temporary and permanent stabilization BMPs after active construction is completed. Inspection activities will continue until adequate permanent stabilization has been established and will continue in areas where re-vegetation is chosen until minimum vegetative coverage has been established. Photographs shall be taken during site inspections and submitted to the State Water Board.

b. Type 2 & 3 LUP Monitoring Requirements

A discharger must conduct daily visual inspections of Type 2 & 3 LUPs during working hours while construction activities are occurring. Inspections are to be conducted by qualified personnel and can be in conjunction with other daily activities.

All dischargers of Type 2 & 3 LUPs are required to conduct inspections by qualified personnel of the construction site during normal working hours prior to all anticipated storm events and after actual storm events. During extended storm events, the discharger shall conduct inspections during normal working hours for each 24-hour period. Inspections can be discontinued in non-active construction areas where soil disturbing activities have been completed and final stabilization has been achieved (e.g., trench has been paved, substructures installed, and successful vegetative cover or other stabilization criteria have been met).

The goals of these inspections are (1) to identify areas contributing to a storm water discharge; (2) to evaluate whether measures to reduce pollutant loadings identified in the SWPPP are adequate and properly installed and functioning in accordance with the terms of the General Permit; and (3) to determine whether additional control practices or corrective maintenance activities are needed. Equipment, materials, and workers must be available for rapid response to failures and emergencies. All corrective maintenance to BMPs shall be performed as soon as possible, depending upon worker safety.

All dischargers shall develop and implement a monitoring program for inspecting Type 2 & 3 LUPs that require temporary and permanent stabilization BMPs after active construction is completed. Inspections will be conducted to ensure the BMPs are adequate and maintained. Inspection activities will continue until adequate permanent stabilization has been established and will continue in areas where revegetation is chosen until minimum vegetative coverage has been established.

A log of inspections conducted before, during, and after the storm events must be maintained in the SWPPP. The log will provide the date and time of the inspection and who conducted the inspection. Photographs must be taken during site inspections and submitted to the State Water Board.

C. Sampling Requirements for all LUP Project Types

LUPs are also subject to sampling and analysis requirements for visible pollutants (i.e., sedimentation/siltation, turbidity) and for non-visible pollutants.

Sampling for visible pollutants is required for Type 2 & 3 LUPs.

Non-visible pollutant monitoring is required for pollutants associated with construction sites and activities that (1) are not visually detectable in storm water discharges, and (2) are known or should be known to occur on the construction site, and (3) could cause or contribute to an exceedance of water quality objectives in the receiving waters. Sample collection for non-visible pollutants must only be required (1) during a storm event when pollutants associated with construction activities may be discharged with storm water runoff due to a spill, or in the event there was a breach, malfunction, failure, and/or leak of any BMP, and (2) when the discharger has failed to adequately clean the area of material and pollutants. Failure to implement appropriate BMPs will trigger the same sampling requirements as those required for a breach, malfunction and/or leak, or when the discharger has failed to implement appropriate BMPs prior to the next storm event.

Additional monitoring parameters may be required by the Regional Water Boards.

It is not anticipated that many LUPs will be required to collect samples for pollutants not visually detected in runoff due to the nature and character of the construction site and activities as previously described in this fact sheet. Most LUPs are constructed in urban areas with public access (e.g., existing roadways, road shoulders, parking areas, etc.). This raises a concern regarding the potential contribution of pollutants from vehicle use and/or from normal activities of the public (e.g., vehicle washing, landscape fertilization, pest spraying, etc.) in runoff from the project site. Since the dischargers are not the land owners of the project area and are not able to control the presence of these pollutants in the storm water that runs through their projects, it is not the intent of this General Permit to require dischargers to sample for these pollutants. This General Permit does not require the discharger to sample for these types of pollutants except where the discharger has brought materials onsite that contain these pollutants and when a condition (e.g., breach, failure, etc.) described above occurs.

3. Receiving Water Monitoring

In order to ensure that receiving water limitations are met, dischargers subject to receiving water monitoring triggers (i.e., Risk Level 3 and LUP Type 3 sites) or numeric effluent limitations (i.e., Risk Level 3 and LUP Type 3 sites utilizing ATS with direct discharges into receiving waters) must also monitor the downstream receiving water(s) for turbidity, SSC, and pH (if applicable) when a receiving water monitoring trigger or NEL is exceeded.

a. Bioassessment Monitoring

This General Permit requires a bioassessment of receiving waters for dischargers of Risk Level 3 or LUP Type 3 construction projects equal to or larger than 30 acres with direct discharges into receiving waters. Benthic macroinvertebrate samples will be taken upstream and downstream of the site's discharge point in the receiving water. Bioassessments measure the quality of the stream by analyzing the aquatic life present. Higher levels of appropriate aquatic species tend to indicate a healthy stream; whereas low levels of organisms can indicate stream degradation. Active construction sites have the potential to discharge large amounts of sediment and pollutants into receiving waters. Requiring a bioassessment for large project sites, with the most potential to impact water quality, provides a snapshot of the health of the receiving water prior to initiation of construction activities. This snapshot can be used in comparison to the health of the receiving water after construction has commenced.

Each ecoregion (biologically and geographically related area) in the State has a specific yearly peak time where stream biota is in a stable and abundant state. This time of year is called an Index Period. The bioassessment requirements in this General Permit, requires benthic macroinvertebrate sampling within a sites index period. The State Water Board has developed a map designating index periods for the ecoregions in the State (see State Water Board Website).

This General Permit requires the bioassessment methods to be in accordance with the Surface Water Ambient Monitoring Program (SWAMP) in order to provide data consistency within the state as well as generate useable biological stream data.

Table 6 - Receiving Water Monitoring Requirements

	Receiving Water Monitoring Parameters
Risk Level 1 /LUP Type 1	not required
Risk Level 2 / LUP Type 2	not required
Risk Level 3 / LUP Type 3	If Receiving Water Monitoring Trigger exceeded: pH (if applicable), turbidity, and SSC. Bioassessment for sites 30 acres or larger.

4. Reporting Requirements

a. NAL Exceedance Report

All Risk Level 3 and LUP Type 3 dischargers must electronically submit all storm event sampling results to the State And Regional Boards, via the electronic data system, no later than 10 days after the conclusion of the storm event.

b. Annual Report

All dischargers must prepare and electronically submit an annual report no later than September 1 of each year using the Storm water Multi-Application Reporting and Tracking System (SMARTS). The

Annual Report must include a summary and evaluation of all sampling and analysis results, original laboratory reports, chain of custody forms, a summary of all corrective actions taken during the compliance year, and identification of any compliance activities or corrective actions that were not implemented.

5. Record Keeping

According to 40 C.F.R. Parts 122.21(p) and 122.41(j), the discharger is required to retain paper or electronic copies of all records required by this General Permit for a period of at least three years from the date generated or the date submitted to the State Water Board or Regional Water Boards. A discharger must retain records for a period beyond three years as directed by Regional Water Board.

J. Risk Determination

1. Traditional Projects

a. Overall Risk Determination

There are two major requirements related to site planning and risk determination in this General Permit. The project's overall risk is broken up into two elements – (1) project sediment risk (the relative amount of sediment that can be discharged, given the project and location details) and (2) receiving water risk (the risk sediment discharges pose to the receiving waters).

Project Sediment Risk:

Project Sediment Risk is determined by multiplying the R, K, and LS factors from the Revised Universal Soil Loss Equation (RUSLE) to obtain an estimate of project-related bare ground soil loss expressed in tons/acre. The RUSLE equation is as follows:

$$A = (R)(K)(LS)(C)(P)$$

Where: A = the rate of sheet and rill erosion

R = rainfall-runoff erosivity factor

K = soil erodibility factor

LS = length-slope factor

C = cover factor (erosion controls)

P = management operations and support practices (sediment controls)

The C and P factors are given values of 1.0 to simulate bare ground conditions.

There is a map option and a manual calculation option for determining soil loss. For the map option, the R factor for the project is calculated using the online calculator at <http://cfpub.epa.gov/npdes/stormwater/LEW/lewCalculator.cfm>. The product of K and LS are shown on Figure 1. To determine soil loss in tons per acre, the discharger multiplies the R factor times the value for K times LS from the map.

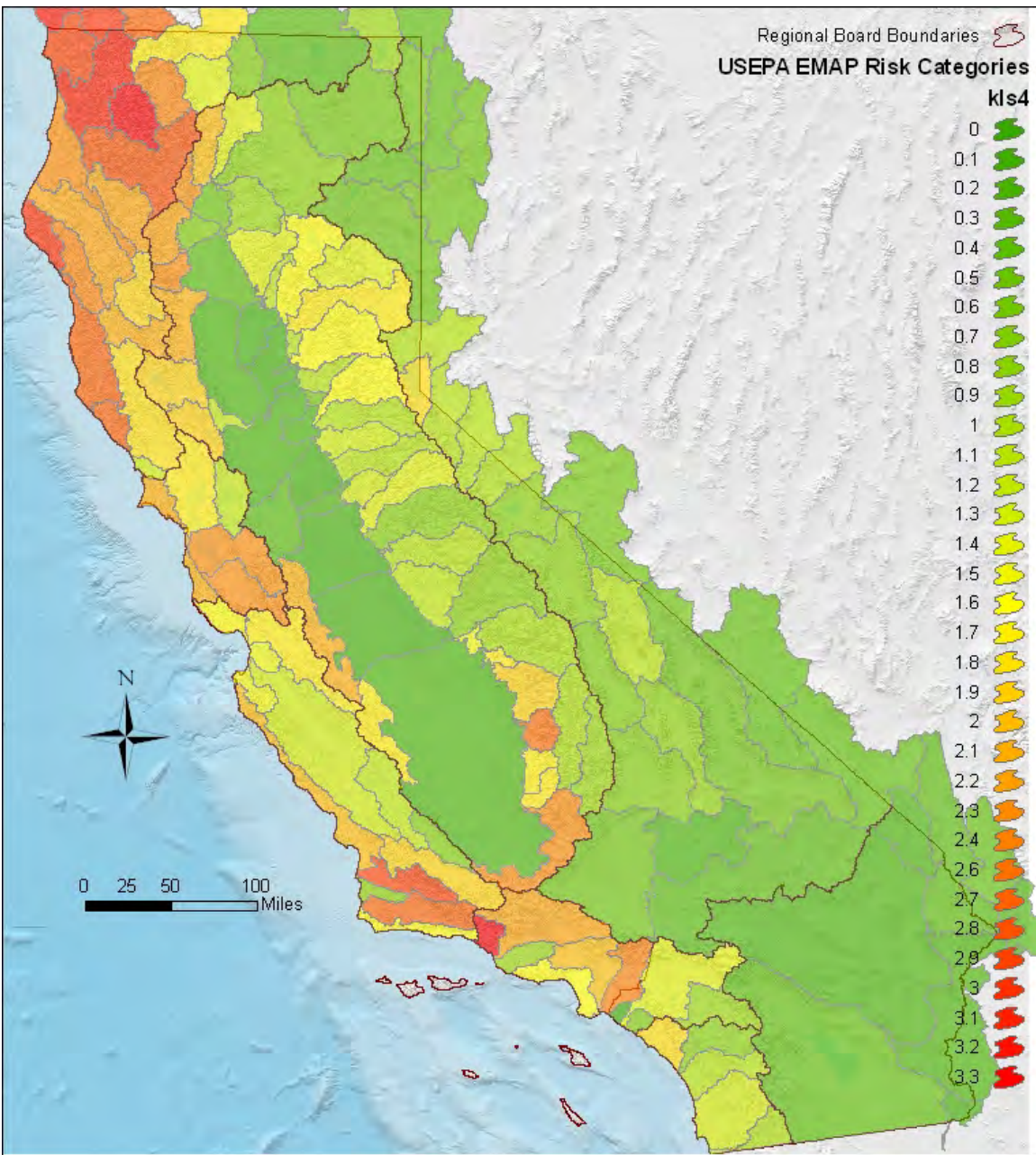

State Water Resources Control Board, January 15, 2008

Figure 1 -Statewide Map of K * LS

For the manual calculation option, the R factor for the project is calculated using the online calculator at <http://cfpub.epa.gov/npdes/stormwater/LEW/lewCalculator.cfm>. The K and LS factors are determined using Appendix 1.

Soil loss of less than 15 tons/acre is considered **low** sediment risk.
 Soil loss between 15 and 75 tons/acre is **medium** sediment risk.
 Soil loss over 75 tons/acre is considered **high** sediment risk.

The soil loss values and risk categories were obtained from mean and standard deviation RKLS values from the USEPA EMAP program. High risk is the mean RKLS value plus two standard deviations. Low risk is the mean RKLS value minus two standard deviations.

Receiving Water Risk:

Receiving water risk is based on whether a project drains to a sediment-sensitive waterbody. A sediment-sensitive waterbody is either

- on the most recent 303d list for waterbodies impaired for sediment;
- has a USEPA-approved Total Maximum Daily Load implementation plan for sediment; **or**
- has the beneficial uses of COLD, SPAWN, and MIGRATORY.

A project that meets at least one of the three criteria has a high receiving water risk. A list of sediment-sensitive waterbodies will be posted on the State Water Board’s website. It is anticipated that an interactive map of sediment sensitive water bodies in California will be available in the future.

The Risk Levels have been altered by eliminating the possibility of a Risk Level 4, and expanding the constraints for Risk Levels 1, 2, and 3. Therefore, projects with high receiving water risk and high sediment risk will be considered a Risk Level 3 risk to water quality.

In response to public comments, the Risk Level requirements have also been changed such that Risk Level 1 projects will be subject to minimum BMP and visual monitoring requirements, Risk Level 2 projects will be subject to NALs and some additional monitoring requirements, and Risk Level 3 projects will be subject to NALs, and more rigorous monitoring requirements such as receiving water monitoring and in some cases bioassessment.

Table 7 - Combined Risk Level Matrix

Combined Risk Level Matrix			
Receiving Water Risk		Sediment Risk	
		Low	Medium
	Low	Level 1	Level 2
High	Level 2		Level 3

b. Effluent Standards

All dischargers are subject to the narrative effluent limitations specified in the General Permit. The narrative effluent limitations require storm water discharges associated with construction activity to meet all applicable provisions of Sections 301 and 402 of the CWA. These provisions require controls of pollutant discharges that utilize BAT and BCT to reduce pollutants and any more stringent controls necessary to meet water quality standards.

Risk Level 2 dischargers that pose a medium risk to water quality are subject to technology-based NALs for pH and turbidity. Risk Level 3 dischargers that pose a high risk to water quality are also subject to technology-based NALs for pH and turbidity.

c. Good Housekeeping

Proper handling and managing of construction materials can help minimize threats to water quality. The discharger must consider good housekeeping measures for: construction materials, waste management, vehicle storage & maintenance, landscape materials, and potential pollutant sources. Examples include; conducting an inventory of products used, implementing proper storage & containment, and properly cleaning all leaks from equipment and vehicles.

d. Non-Storm Water Management

Non-storm water discharges directly connected to receiving waters or the storm drain system have the potential to negatively impact water quality. The discharger must implement measures to control all non-storm water discharges during construction, and from dewatering activities associated with construction. Examples include; properly washing vehicles in contained areas, cleaning streets, and minimizing irrigation runoff.

e. Erosion Control

The best way to minimize the risk of creating erosion and sedimentation problems during construction is to disturb as little of the land surface as possible by fitting the development to the terrain. When development is tailored to the natural contours of the land, little grading is necessary and, consequently, erosion potential is lower.¹⁴ Other effective erosion control measures include: preserving existing vegetation where feasible, limiting disturbance, and stabilizing and re-vegetating disturbed areas as soon as possible after grading or construction activities. Particular attention must be paid to large, mass-graded sites where the potential for soil exposure to the erosive effects of rainfall and wind is great and where there is potential for significant sediment discharge from the site to surface waters. Until permanent vegetation is established, soil cover is the most cost-effective and expeditious method to protect soil particles from detachment and transport by rainfall. Temporary soil stabilization can be the single most important factor in reducing erosion at construction sites. The discharger is required to consider measures such as: covering disturbed areas with mulch, temporary seeding, soil stabilizers, binders, fiber rolls or blankets, temporary vegetation, and permanent seeding. These erosion control measures are only examples of what should be considered and should not preclude new or innovative approaches currently available or being developed. Erosion control BMPs should be the primary means of preventing storm water contamination, and sediment control techniques should be used to capture any soil that becomes eroded.¹²

Risk Level 3 dischargers pose a higher risk to water quality and are therefore additionally required to ensure that post-construction soil loss is equivalent to or less than the pre-construction levels.

f. Sediment Control

Sediment control BMPs should be the secondary means of preventing storm water contamination. When erosion control techniques are ineffective, sediment control techniques should be used to capture any soil that becomes eroded. The discharger is required to consider perimeter control measures such as: installing silt fences or placing straw wattles below slopes. These sediment control measures are only

¹² U.S. Environmental Protection Agency. 2007. Developing Your Storm Water Pollution Prevention Plan: A Guide for Construction Sites.

examples of what should be considered and should not preclude new or innovative approaches currently available or being developed.

Because Risk Level 2 and 3 dischargers pose a higher risk to water quality, additional requirements for the application of sediment controls are imposed on these projects. This General Permit also authorizes the Regional Water Boards to require Risk Level 3 dischargers to implement additional site-specific sediment control requirements if the implementation of other erosion or sediment controls are not adequately protecting the receiving waters.

g. Run-on and Runoff Control

Inappropriate management of run-on and runoff can result in excessive physical impacts to receiving waters from sediment and increased flows. The discharger is required to manage all run-on and runoff from a project site. Examples include: installing berms and other temporary run-on and runoff diversions.

Risk Level 1 dischargers with lower risks to impact water quality are not subject to the run-on and runoff control requirements unless an evaluation deems them necessary or visual inspections show that such controls are required.

h. Inspection, Maintenance and Repair

All measures must be periodically inspected, maintained and repaired to ensure that receiving water quality is protected. Frequent inspections coupled with thorough documentation and timely repair is necessary to ensure that all measures are functioning as intended.

i. Rain Event Action Plan (REAP)

A Rain Event Action Plan (REAP) is a written document, specific for each rain event. A REAP should be designed that when implemented it protects all exposed portions of the site within 48 hours of any likely precipitation event forecast of 50% or greater probability.

This General Permit requires Risk Level 2 and 3 dischargers to develop and implement a REAP designed to protect all exposed portions of their sites within 48 hours prior to any likely precipitation event. The REAP requirement is designed to ensure that the discharger has adequate materials, staff, and time to implement erosion and sediment control measures that are intended to reduce the amount of sediment and other pollutants generated from the active site. A REAP must be developed when there is likely a forecast of 50% or greater probability of precipitation in the project area. (The National Oceanic and Atmospheric Administration (NOAA) defines a chance of precipitation as a probability of precipitation of 30% to 50% chance of producing precipitation in the project area.¹³ NOAA defines the probability of precipitation (PoP) as the likelihood of occurrence (expressed as a percent) of a measurable amount (0.01 inch or more) of liquid precipitation (or the water equivalent of frozen precipitation) during a specified period of time at any given point in the forecast area.) Forecasts are normally issued for 12-hour time periods. Descriptive terms for uncertainty and aerial coverage are used as follows:

Table 8 -National Oceanic and Atmospheric Administration (NOAA) Definition of Probability of Precipitation (PoP)

¹³ <http://www.crh.noaa.gov/lot/severe/wxterms.php>.

PoP	Expressions of Uncertainty	Aerial Coverage
0%	none used	none used
10%	none used	isolated
20%	slight chance	isolated
30-50%	chance	scattered
60-70%	likely	numerous
80-100%	none used	none used

The discharger must obtain the precipitation forecast information from the National Weather Service Forecast Office (<http://www.srh.noaa.gov/>).

2. Linear Projects

a. Linear Risk Determination

LUPs vary in complexity and water quality concerns based on the type of project. This General Permit has varying application requirements based on the project's risk to water quality. Factors that lead to the characterization of the project include location, sediment risk, and receiving water risk.

Based on the location and complexity of a project area or project section area, LUPs are separated into project types. As described below, LUPs have been categorized into three project types.

i. *Type 1 LUPs*

Type 1 LUPs are those construction projects where:

- (1) 70 percent or more of the construction activity occurs on a paved surface and where areas disturbed during construction will be returned to preconstruction conditions or equivalent protection established at the end of the construction activities for the day, or
- (2) greater than 30 percent of construction activities occur within the non-paved shoulders or land immediately adjacent to paved surfaces, or where construction occurs on unpaved improved roads, including their shoulders or land immediately adjacent to them where:

Areas disturbed during construction will be returned to pre-construction conditions or equivalent protection established at the end of the construction activities for the day to minimize the potential for erosion and sediment deposition, and

Areas where established vegetation was disturbed during construction will be stabilized and re-vegetated by the end of project. When required, adequate temporary stabilization Best Management Practices (BMPs) will be installed and maintained until vegetation is established to meet minimum cover requirements established in this General Permit for final stabilization.

Type 1 LUPs typically do not have a high potential to impact storm water quality because (1) these construction activities are not typically conducted during a rain event, (2) these projects are normally constructed over a short period of time¹⁴, minimizing the duration that pollutants could potentially be exposed to rainfall; and (3) disturbed soils such as those from trench excavation are required to be hauled away, backfilled into the trench, and/or covered (e.g., metal plates, pavement, plastic covers over spoil piles) at the end of the construction day.

Type 1 LUPs are determined during the risk assessment found in Attachment A.1 to be 1) low sediment risk and low receiving water risk; 2) low sediment risk and medium receiving water risk; and 3) medium sediment risk and low receiving water risk.

This General Permit requires the discharger to ensure a SWPPP is developed for these construction activities that is specific to project type, location and characteristics.

ii. Type 2 LUPs:

Type 2 projects are determined to have a combination of High, Medium, and Low project sediment risk along with High, Medium, and Low receiving water risk. Like Type 1 projects, Type 2 projects are typically constructed over a short period of time. However, these projects have a higher potential to impact water quality because they:

- (1) typically occur outside the more urban/developed areas;
- (2) have larger areas of soil disturbance that are not closed or restored at the end of the day;
- (3) may have onsite stockpiles of soil, spoil and other materials;
- (4) cross or occur in close proximity to a wide variety of sensitive resources that may include, but are not limited to, steep topography and/or water bodies; and
- (5) have larger areas of disturbed soils that may be exposed for a longer time interval before final stabilization, cleanup and/or reclamation occurs.

This General Permit requires the discharger to develop and implement a SWPPP for these construction activities that are specific for project type, location and characteristics.

iii. Type 3 LUPs:

¹⁴ Short period of time refers to a project duration of weeks to months, but typically less than one year in duration.

Type 3 projects are determined to have a combination of High and Medium project sediment risk along with High and Medium receiving water risk. Similar to Type 2 projects, Type 3 projects have a higher potential to impact water quality because they:

- (1) typically occur outside of the more urban/developed areas;
- (2) have larger areas of soil disturbance that are not closed or restored at the end of the day;
- (3) may have onsite stockpiles of soil, spoil and other materials;
- (4) cross or occur in close proximity to a wide variety of sensitive resources that may include, but are not limited to, steep topography and/or water bodies; and
- (5) have larger areas of disturbed soils that may be exposed for a longer time interval before final stabilization, cleanup and/or reclamation occurs.

This General Permit requires the discharger to develop and implement a SWPPP for these construction activities that are specific for project type, location, and characteristics.

b. Linear Effluent Standards

All LUPs are subject to the narrative effluent limitations specified in the General Permit.

Type 2 and Type 3 projects are subject to technology-based NALs for pH and turbidity.

c. Linear Good Housekeeping

Improper use and handling of construction materials could potentially cause a threat to water quality. In order to ensure proper site management of these construction materials, all LUP dischargers must comply with a minimum set of Good Housekeeping measures specified in Attachment A of this General Permit.

d. Linear Non-Storm Water Management

In order to ensure control of all non-storm water discharges during construction, all LUP dischargers must comply with the Non-Storm Water Management measures specified in Attachment A of this General Permit.

e. Linear Erosion Control

This General Permit requires all LUP dischargers to implement effective wind erosion control measures, and soil cover for inactive areas. Type 3 LUPs posing a higher risk to water quality are additionally required to ensure the post-construction soil loss is equivalent to or less than the pre-construction levels.

f. Linear Sediment Control

In order to ensure control and containment of all sediment discharges, all LUP dischargers must comply with the general Sediment Control measures specified in Attachment A or this General Permit. Additional requirements for sediment controls are imposed on Type 2 & 3 LUPs due to their higher risk to water quality.

g. Linear Run-on and Runoff Control

Discharges originating outside of a project's perimeter and flowing onto the property can adversely affect the quantity and quality of discharges originating from a project site. In order to ensure proper management of run-on and runoff, all LUPs must comply with the run-on and runoff control measures specified in Attachment A of this General Permit. Due to the lower risk of impacting water quality, Type 1 LUPs are not required to implement run-on and runoff controls unless deemed necessary by the discharger.

h. Linear Inspection, Maintenance and Repair

Proper inspection, maintenance, and repair activities are important to ensure the effectiveness of on-site measures to control water quality. In order to ensure that inspection, maintenance, and repair activities are adequately performed, the all LUP dischargers are required to comply with the Inspection, Maintenance, and Repair requirements specified in Attachment A of this General Permit.

K. ATS¹⁵ Requirements

There are instances on construction sites where traditional erosion and sediment controls do not effectively control accelerated erosion. Under such circumstances, or under circumstances where storm water discharges leaving the site may cause or contribute to an exceedance of a water quality standard, the use of an Active Treatment System (ATS) may be necessary. Additionally, it may be appropriate to use an ATS when site constraints inhibit the ability to construct a correctly sized sediment basin, when clay and/or highly erosive soils are present, or when the site has very steep or long slope lengths.¹⁶

Although treatment systems have been in use in some form since the mid-1990s, the ATS industry in California is relatively young, and detailed regulatory standards have not yet been developed. Many developers are using these systems to treat storm water discharges from their construction sites. The new ATS requirements set forth in this General Permit are based on those in place for small wastewater treatment systems, ATS regulations from the Central Valley Regional Water Quality Control Board (September 2005 memorandum "2005/2006 Rainy Season – Monitoring Requirements for Storm Water Treatment Systems that Utilize Chemical Additives to Enhance Sedimentation"), the Construction Storm Water Program at the State of Washington's Department of Ecology, as well as recent advances in technology and knowledge of coagulant performance and aquatic safety.

The effective design of an ATS requires a detailed survey and analysis of site conditions. With proper planning, ATS performance can provide exceptional water quality discharge and prevent significant impacts to surface water quality, even under extreme environmental conditions.

These systems can be very effective in reducing the sediment in storm water runoff, but the systems that use additives/polymers to enhance sedimentation also pose a potential risk to water quality (e.g., operational failure, equipment failure, additive/polymer release, etc.). The State Water Board is concerned about the potential acute and chronic impacts that the polymers and other chemical additives may have on fish and aquatic organisms if released in sufficient quantities or concentrations. In addition

¹⁵ An ATS is a treatment system that employs chemical coagulation, chemical flocculation, or electrocoagulation in order to reduce turbidity caused by fine suspended sediment.

¹⁶ Pitt, R., S. Clark, and D. Lake. 2006. Construction Site Erosion and Sediment Controls: Planning, Design, and Performance. DEStech Publications. Lancaster, PA. 370pp.

to anecdotal evidence of polymer releases causing aquatic toxicity in California, the literature supports this concern.¹⁷ For example, cationic polymers have been shown to bind with the negatively charged gills of fish, resulting in mechanical suffocation.¹⁸ Due to the potential toxicity impacts, which may be caused by the release of additives/polymers into receiving waters, this General Permit establishes residual polymer monitoring and toxicity testing requirements have been established in this General Permit for discharges from construction sites that utilize an ATS in order to protect receiving water quality and beneficial uses.

The primary treatment process in an ATS is coagulation/flocculation. ATS's operate on the principle that the added coagulant is bound to suspended sediment, forming floc, which is gravitationally settled in tanks or a basin, or removed by sand filters. A typical installation utilizes an injection pump upstream from the clarifier tank, basin, or sand filters, which is electronically metered to both flow rate and suspended solids level of the influent, assuring a constant dose. The coagulant mixes and reacts with the influent, forming a dense floc. The floc may be removed by gravitational setting in a clarifier tank or basin, or by filtration. Water from the clarifier tank, basin, or sand filters may be routed through cartridge(s) and/or bag filters for final polishing. Vendor-specific systems use various methods of dose control, sediment/floc removal, filtration, etc., that are detailed in project-specific documentation. The particular coagulant/flocculant to be used for a given project is determined based on the water chemistry of the site because the coagulants are specific in their reactions with various types of sediments. Appropriate selection of dosage must be carefully matched to the characteristics of each site.

ATS's are operated in two differing modes, either Batch or Flow-Through. Batch treatment can be defined as Pump-Treat-Hold-Test-Release. In Batch treatment, water is held in a basin or tank, and is not discharged until treatment is complete. Batch treatment involves holding or recirculating the treated water in a holding basin or tank(s) until treatment is complete or the basin or storage tank(s) is full. In Flow-Through treatment, water is pumped into the ATS directly from the runoff collection system or storm water holding pond, where it is treated and filtered as it flows through the system, and is then directly discharged. "Flow-Through Treatment" is also referred to as "Continuous Treatment."

1. Effluent Standards

This General Permit establishes NELs for discharges from construction sites that utilize an ATS. These systems lend themselves to NELs for turbidity and pH because of their known reliable treatment. Advanced systems have been in use in some form since the mid-1990s. An ATS is considered reliable, can consistently produce a discharge of less than 10 NTU, and has been used successfully at many sites in several states since 1995 to reduce turbidity to very low levels.¹⁹

This General Permit contains "compliance storm event" exceptions from the technology-based NELs for ATS discharges. The rationale is that technology-based requirements are developed assuming a certain design storm. In the case of ATS the industry-standard design storm is 10-year, 24-hour (as stated in

¹⁷ Romøen, K., B. Thu, and Ø. Evensen. 2002. Immersion delivery of plasmid DNA II. A study of the potentials of a chitosan based delivery system in rainbow trout (*Oncorhynchus mykiss*) fry. *Journal of Controlled Release* **85**: 215-225.

¹⁸ Bullock, G., V. Blazer, S. Tsukuda, and S. Summerfelt. 2000. Toxicity of acidified chitosan for cultured rainbow trout (*Oncorhynchus mykiss*). *Aquaculture* **185**:273-280.

¹⁹ Currier, B., G. Minton, R. Pitt, L. Roesner, K. Schiff, M. Stenstrom, E. Strassler, and E. Strecker. 2006. The Feasibility of Numeric Effluent Limits Applicable to Discharges of Storm Water Associated with Municipal, Industrial and Construction Activities.

Attachment F of this General Permit), so the compliance storm event has been established as the 10-year 24-hour event as well to provide consistency.

2. Training

Operator training is critical to the safe and efficient operation and maintenance of the ATS, and to ensure that all State Water Board monitoring and sampling requirements are met. The General Permit requires that all ATS operators have training specific to using ATS's liquid coagulants.

L. Post-Construction Requirements

Under past practices, new and redevelopment construction activities have resulted in modified natural watershed and stream processes. This is caused by altering the terrain, modifying the vegetation and soil characteristics, introducing impervious surfaces such as pavement and buildings, increasing drainage density through pipes and channels, and altering the condition of stream channels through straightening, deepening, and armoring. These changes result in a drainage system where sediment transport capacity is increased and sediment supply is decreased. A receiving channel's response is dependent on dominant channel materials and its stage of adjustment.

Construction activity can lead to impairment of beneficial uses in two main ways. First, during the actual construction process, storm water discharges can negatively affect the chemical, biological, and physical properties of downstream receiving waters. Due to the disturbance of the landscape, the most likely pollutant is sediment, however pH and other non-visible pollutants are also of great concern. Second, after most construction activities are completed at a construction site, the finished project may result in significant modification of the site's response to precipitation. New development and redevelopment projects have almost always resulted in permanent post-construction water quality impacts because more precipitation ends up as runoff and less precipitation is intercepted, evapotranspired, and infiltrated.

General Permit 99-08-DWQ required the SWPPP to include a description of all post-construction BMPs on a site and a maintenance schedule. An effective storm water management strategy must address the full suite of storm events (water quality, channel protection, overbank flood protection, extreme flood protection) (Figure 2).

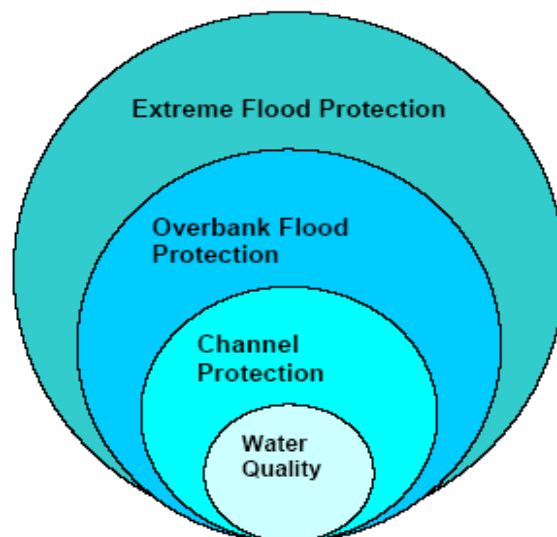

Figure 2 - Suite of Storm Events

The post-construction storm water performance standards in this General Permit specifically address water quality and channel protection events. Overbank flood protection and extreme flood protection events are traditionally dealt with in local drainage and flood protection ordinances. However, measures in this General Permit to address water quality and channel protection also reduce overbank and extreme flooding impacts. This General Permit aims to match post-construction runoff to pre-construction runoff for the 85th percentile storm event, which not only reduces the risk of impact to the receiving water's channel morphology but also provides some protection of water quality.

This General Permit clarifies that its runoff reduction requirements only apply to projects that lie outside of jurisdictions covered by a Standard Urban Storm water Management Plan (SUSMP) (or other more protective) post-construction requirements in either Phase I or Phase II permits.

Figures 3 and 4, below, show the General Permit enrollees (to Order 99-08-DWQ, as of March 10, 2008) overlaid upon a map with SUSMP (or more protective) areas in blue and purple. Areas without blue or purple indicate where the General Permit's runoff reduction requirements would actually apply.

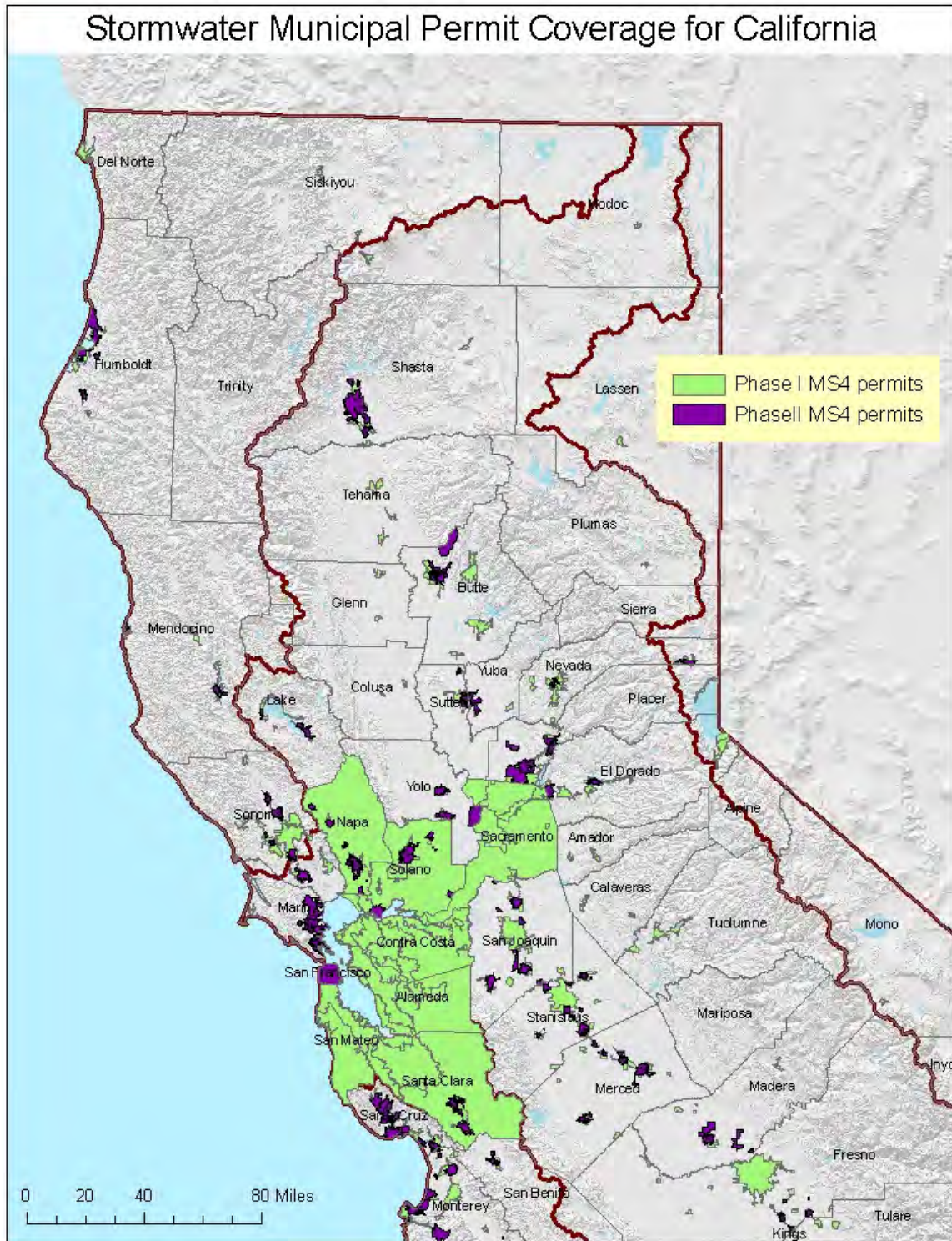
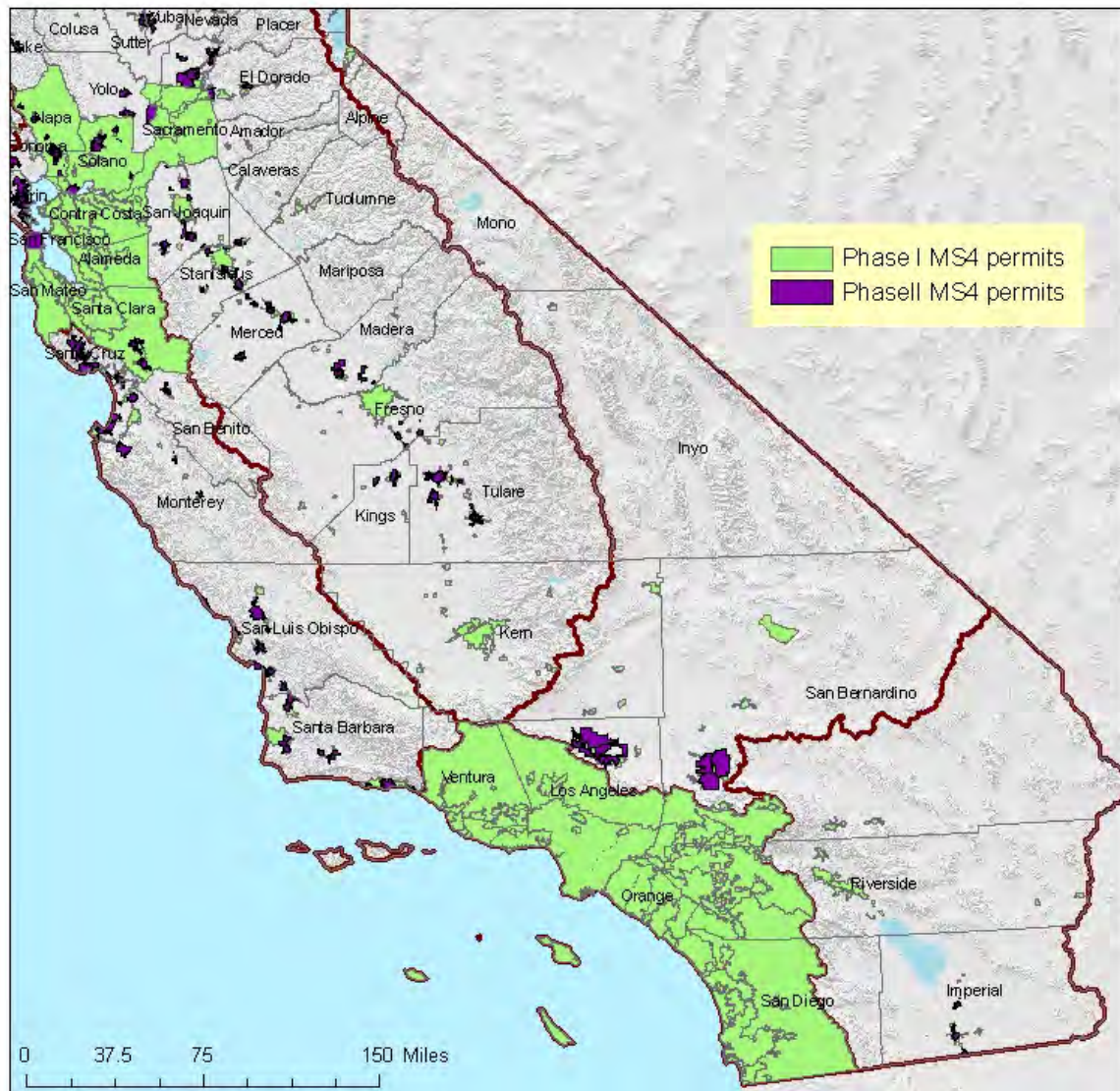

Figure 3 - Northern CA (2009) Counties / Cities With SUSMP-Plus Coverage



Stormwater Municipal Permit Coverage for California

Figure 4 - Southern CA (2009) Counties / Cities With SUSMP-Plus Coverage

Water Quality:

This General Permit requires dischargers to replicate the pre-project runoff water balance (defined as the amount of rainfall that ends up as runoff) for the smallest storms up to the 85th percentile storm event, or the smallest storm event that generates runoff, whichever is larger. Contemporary storm water management generally routes these flows directly to the drainage system, increasing pollutant loads and potentially causing adverse effects on receiving waters. These smaller water quality events happen much more frequently than larger events and generate much higher pollutant loads on an annual basis. There are other adverse hydrological impacts that result from not designing according to the site's pre-construction water balance. In Maryland, Klein²⁰ noted that baseflow decreases as the extent of urbanization increases. Ferguson and Suckling²¹ noted a similar relation in watersheds in Georgia. On Long Island, Spinello and Simmons²² noted substantial decreases in base flow in intensely urbanized watersheds.

The permit emphasizes runoff reduction through on-site storm water reuse, interception, evapotranspiration and infiltration through non-structural controls and conservation design measures (e.g., downspout disconnection, soil quality preservation/enhancement, interceptor trees). Employing these measures close to the source of runoff generation is the easiest and most cost-effective way to comply with the pre-construction water balance standard. Using low-tech runoff reduction techniques close to the source is consistent with a number of recommendations in the literature.²³ In many cases, BMPs implemented close to the source of runoff generation cost less than end-of the pipe measures.²⁴ Dischargers are given the option of using Appendix 2 to calculate the required runoff volume or a watershed process-based, continuous simulation model such as the EPA's Storm Water Management Model (SWMM) or Hydrologic Simulation Program Fortran (HSPF). Such methods used by the discharger will be reviewed by the Regional Water Board upon NOT application.

Channel Protection:

In order to address channel protection, a basic understanding of fluvial geomorphic concepts is necessary. A dominant paradigm in fluvial geomorphology holds that streams adjust their channel dimensions (width and depth) in response to long-term changes in sediment supply and bankfull discharge (1.5 to 2 year recurrence interval). The bankfull stage corresponds to the discharge at which channel maintenance is the most effective, that is, the discharge at which the moving sediment, forming or removing bars, forming or changing bends and meanders, and generally doing work that results in the average morphologic characteristics of channels.²⁵ Lane (1955 as cited in Rosgen 1996²⁶) showed the generalized relationship between sediment load, sediment size, stream discharge and stream slope in

²⁰ Klein 1979 as cited in Delaware Department of Natural Resources (DDNR). 2004. Green Technology: The Delaware Urban Runoff Management Approach. Dover, DE. 117 pp.

²¹ Ferguson and Suckling 1990 as cited Delaware Department of Natural Resources (DDNR). 2004. Green Technology: The Delaware Urban Runoff Management Approach. Dover, DE. 117 pp.

²² Center for Watershed Protection (CWP). 2000. The Practice of Watershed Protection: Techniques for protecting our nation's streams, lakes, rivers, and estuaries. Ellicott City, MD. 741 pp.

²³ Bay Area Storm Water Management Agencies Association (BASMAA). 1997. Start at the Source: Residential Site Planning and Design Guidance Manual for Storm Water Quality Protection. Palo Alto, CA;

McCuen, R.H. 2003 Smart Growth: hydrologic perspective. Journal of Professional Issues in Engineering Education and Practice. Vol (129), pp.151-154;

Moglen, G.E. and S. Kim. 2007. Impervious imperviousness-are threshold based policies a good idea? Journal of the American Planning Association, Vol 73 No. 2. pp 161-171.

²⁴ Delaware Department of natural Resources (DDNR). 2004. Green technology: The Delaware urban Runoff Management Approach. Dover, DE. 117 pp.

²⁵ Dunne, T and L.B. Leopold. 1978. Water in Environmental Planning. San Francisco W.H. Freeman and Company

²⁶ Rosgen. D.L. 1996. Applied River Morphology. Pagosa Springs. Wildland Hydrology

Figure 5. A change in any one of these variables sets up a series of mutual adjustments in the companion variables with a resulting direct change in the physical characteristics of the stream channel.

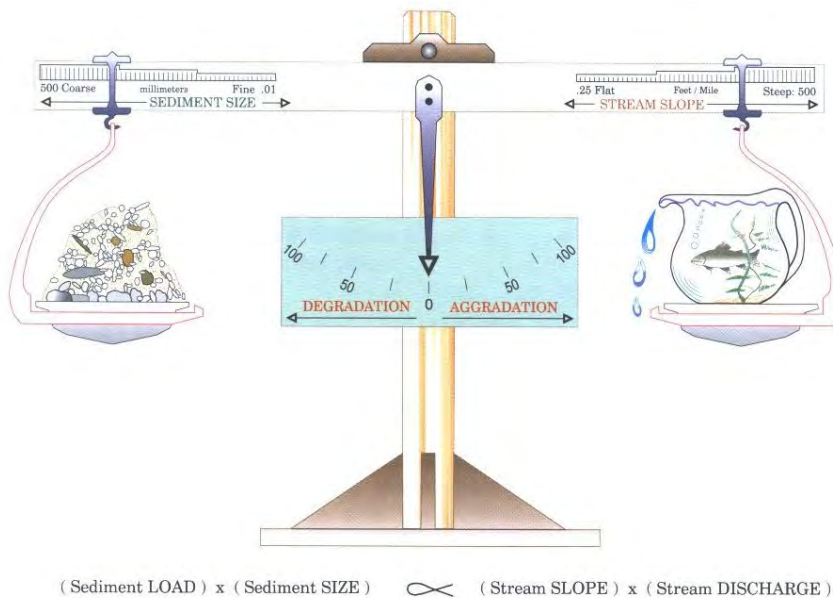

Figure 5 - Schematic of the Lane Relationship
After Lane (1955) as cited in Rosgen (1996)

Stream slope multiplied by stream discharge (the right side of the scale) is essentially an approximation of stream power, a unifying concept in fluvial geomorphology (Bledsoe 1999). Urbanization generally increases stream power and affects the resisting forces in a channel (sediment load and sediment size represented on the left side of the scale).

During construction, sediment loads can increase from 2 to 40,000 times over pre-construction levels.²⁷ Most of this sediment is delivered to stream channels during large, episodic rain events.²⁸ This increased sediment load leads to an initial aggradation phase where stream depths may decrease as sediment fills the channel, leading to a decrease in channel capacity and increase in flooding and overbank deposition. A degradation phase initiates after construction is completed.

Schumm et. al (1984) developed a channel evolution model that describes the series of adjustments from initial downcutting, to widening, to establishing new floodplains at lower elevations (Figure 6).

²⁷ Goldman S.J., K. Jackson, and T.A. Bursztynsky. 1986. Erosion and Sediment Control Handbook. McGraw Hill. San Francisco.

²⁸ Wolman 1967 as cited in Paul, M.P. and J.L. Meyer. 2001. Streams in the Urban Landscape. *Annu. Rev.Ecol. Syst.* 32: 333-365.

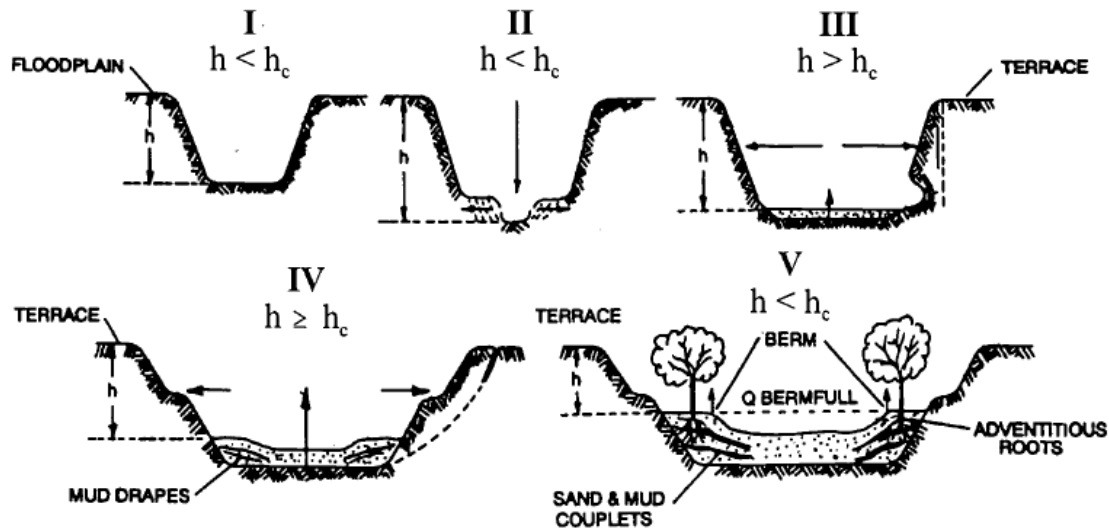

Figure 6 - Channel Changes Associated with Urbanization

After Incised Channel Evolution Sequence in Schumm et. al 1984

Channel incision (Stage II) and widening (Stages III and to a lesser degree, Stage IV) are due to a number of fundamental changes on the landscape. Connected impervious area and compaction of pervious surfaces increase the frequency and volume of bankfull discharges.²⁹ Increased drainage density (miles of stream length per square mile of watershed) also negatively impacts receiving stream channels.³⁰ Increased drainage density and hydraulic efficiency leads to an increase in the frequency and volume of bankfull discharges because the time of concentration is shortened. Flows from engineered pipes and channels are also often “sediment starved” and seek to replenish their sediment supply from the channel.

Encroachment of stream channels can also lead to an increase in stream slope, which leads to an increase in stream power. In addition, watershed sediment loads and sediment size (with size generally represented as the median bed and bank particle size, or d_{50}) decrease during urbanization.³¹ This means

²⁹ Booth, D. B. and C. R. Jackson. 1997. Urbanization of Aquatic Systems: Degradation Thresholds, Storm Water Detection, and the Limits of Mitigation. *Journal of the American Water Resources Association* Vol. 33, No.5, pp. 1077-1089.

³⁰ May, C.W. 1998. Cumulative effects of urbanization on small streams in the Puget Sound Lowland ecoregion. Conference proceedings from Puget Sound Research '98 held March 12, 13 1998 in Seattle, WA;

Santa Clara Valley Urban Runoff Pollution Prevention Program. 2002. Hydromodification Management Plan Literature Review. 80 pp.

³¹ Finkenbine, J.K., D.S. Atwater, and D.S. Mavinic. 2000. Stream health after urbanization. *J. Am. Water Resour. Assoc.* 36:1149-60;

that even if pre- and post-development stream power are the same, more erosion will occur in the post-development stage because the smaller particles are less resistant (provided they are non-cohesive).

As shown in Stages II and III, the channel deepens and widens to accommodate the increased stream power³² and decrease in sediment load and sediment size. Channels may actually narrow as entrained sediment from incision is deposited laterally in the channel. After incised channels begin to migrate laterally (Stage III), bank erosion begins, which leads to general channel widening.³³ At this point, a majority of the sediment that leaves a drainage area comes from within the channel, as opposed to the background and construction related hillslope contribution. Stage IV is characterized by more aggradation and localized bank instability. Stage V represents a new quasi-equilibrium channel morphology in balance with the new flow and sediment supply regime. In other words, stream power is in balance with sediment load and sediment size.

The magnitude of the channel morphology changes discussed above varies along a stream network as well as with the age of development, slope, geology (sand-bedded channels may cycle through the evolution sequence in a matter of decades whereas clay-dominated channels may take much longer), watershed sediment load and size, type of urbanization, and land use history. It is also dependent on a channel's stage in the channel evolution sequence when urbanization occurs. Management strategies

Pizzuto, J.E. W.S. Hession, and M. McBride. 2000. Comparing gravel-bed rivers in paired urban and rural catchments of southeastern Pennsylvania. *Geology* 28:79-82.

³² Hammer 1973 as cited in Delaware Department of Natural Resources (DDNR). 2004. Green Technology: The Delaware Urban Runoff Management Approach. Dover, DE. 117 pp;

Booth, D.B. 1990. Stream Channel Incision Following Drainage Basin Urbanization. *Water Resour. Bull.* 26:407-417.

³³ Trimble, S.W. 1997. Contribution of Stream Channel Erosion to Sediment Yield from an Urbanizing Watershed. *Science*: Vol. 278 (21), pp. 1442-1444.

must take into account a channel's stage of adjustment and account for future changes in the evolution of channel form (Stein and Zaleski 2005).³⁴

Traditional structural water quality BMPs (e.g. detention basins and other devices used to store volumes of runoff) unless they are highly engineered to provide adequate flow duration control, do not adequately protect receiving waters from accelerated channel bed and bank erosion, do not address post-development increases in runoff volume, and do not mitigate the decline in benthic macroinvertebrate communities in the receiving waters³⁵ suggest that structural BMPs are not as effective in protecting aquatic communities as a continuous riparian buffer of native vegetation. This is supported by the findings of Zucker and White³⁶, where instream biological metrics were correlated with the extent of forested buffers.

This General Permit requires dischargers to maintain pre-development drainage densities and times of concentration in order to protect channels and encourages dischargers to implement setbacks to reduce channel slope and velocity changes that can lead to aquatic habitat degradation.

There are a number of other approaches for modeling fluvial systems, including statistical and physical models and simpler stream power models.³⁷ The use of these models in California is described in Stein and Zaleski (2005).³⁸ Rather than prescribe a specific one-size-fits-all modeling method in this permit, the State Water Board intends to develop a stream power and channel evolution model-based framework to assess channels and develop a hierarchy of suitable analysis methods and management strategies. In time, this framework may become a State Water Board water quality control policy.

Permit Linkage to Overbank and Extreme Flood Protection

Site design BMPs (e.g. rooftop and impervious disconnection, vegetated swales, setbacks and buffers) filter and settle out pollutants and provide for more infiltration than is possible for traditional centralized structural BMPs placed at the lowest point in a site. They provide source control for runoff and lead to a reduction in pollutant loads. When implemented, they also help reduce the magnitude and volume of larger, less frequent storm events (e.g., 10-yr, 24-hour storm and larger), thereby reducing the need for expensive flood control infrastructure. Nonstructural BMPs can also be a landscape amenity, instead of a large isolated structure requiring substantial area for ancillary access, buffering, screening and maintenance facilities.²⁵ The multiple benefits of using non-structural benefits will be critically important as the state's population increases and imposes strains upon our existing water resources.

Maintaining predevelopment drainage densities and times of concentration will help reduce post-development peak flows and volumes in areas not covered under a municipal permit. The most effective way to preserve drainage areas and maximize time of concentration is to implement landform grading,

³⁴ Stein, E.S. and S. Zaleski. 2005. Managing runoff to protect natural stream: the latest developments on investigation and management of hydromodification in California. Southern California Coastal Water Research Project Technical Report 475. 26 pp.

³⁵ Horner, R.R. 2006. Investigation of the Feasibility and Benefits of Low-Impact Site Design Practices (LID) for the San Diego Region. Available at: http://www.projectcleanwater.org/pdf/permit/case-study_lid.pdf.

³⁶ Delaware Department of Natural Resources (DDNR). 2004. Green Technology: The Delaware Urban Runoff Management Approach. Dover, DE. 117 pp.

³⁷ Finlayson, D.P. and D.R. Montgomery. 2003. Modeling large-scale fluvial erosion in geographic information systems. *Geomorphology* (53), pp. 147-164).

³⁸ Stein, E.S. and S. Zaleski. 2005. Managing runoff to protect natural stream: the latest developments on investigation and management of hydromodification in California. Southern California Coastal Water Research Project Technical Report 475. 26 pp.

incorporate site design BMPs and implement distributed structural BMPs (e.g., bioretention cells, rain gardens, rain cisterns).

M. Storm Water Pollution Prevention Plans

USEPA's Construction General Permit requires that qualified personnel conduct inspections. USEPA defines qualified personnel as "a person knowledgeable in the principles and practice of erosion and sediment controls who possesses the skills to assess conditions at the construction site that could impact storm water quality and to assess the effectiveness of any sediment and erosion control measures selected to control the quality of storm water discharges from the construction activity."³⁹ USEPA also suggests that qualified personnel prepare SWPPPs and points to numerous states that require certified professionals to be on construction sites at all times. States that currently have certification programs are Washington, Georgia, Florida, Delaware, Maryland, and New Jersey. The Permit 99-08-DWQ did not require that qualified personnel prepare SWPPPs or conduct inspections. However, to ensure that water quality is being protected, this General Permit requires that all SWPPPs be written, amended, and certified by a Qualified SWPPP Developer. A Qualified SWPPP Developer must possess one of the eight certifications and or registrations specified in this General Permit and effective two years after the adoption date of this General Permit, must have attended a State Water Board-sponsored or approved Qualified SWPPP Developer training course. Table 9 provides an overview of the criteria used in determining qualified certification titles for a QSD and QSP.

39 US Environmental Protection Agency. Stormwater Pollution Prevention Plans for Construction Activities. <<http://cfpub.epa.gov/npdes/stormwater/swppp.cfm>> and <http://www.epa.gov/npdes/pubs/sw_swppp_guide.pdf>.

Table 9 - Qualified SWPPP Developer/ Qualified SWPPP Practitioner Certification Criteria

Certification/ Title	Registered By	QSD/QSP	Certification Criteria
Professional Civil Engineer	California	Both	1. Approval Process 2. Code of Ethics 3. Accountability 4. Pre-requisites
Professional Geologist or Engineering Geologist	California	Both	1. Approval Process 2. Code of Ethics 3. Accountability 4. Pre-requisites
Landscape Architect	California	Both	1. Approval Process 2. Code of Ethics 3. Accountability 4. Pre-requisites
Professional Hydrologist	American Institute of Hydrology	Both	1. Approval Process 2. Code of Ethics 3. Accountability 4. Pre-requisites
Certified Professional in Erosion and Sediment Control™ (CPESC)	Enviro Cert International Inc.	Both	1. Approval Process 2. Code of Ethics 3. Accountability 4. Pre-requisites 5. Continuing Education
Certified Inspector of Sediment and Erosion Control™ (CISEC)	Certified Inspector of Sediment and Erosion Control, Inc.	QSP	1. Approval Process 2. Code of Ethics 3. Accountability 4. Pre-requisites 5. Continuing Education
Certified Erosion, Sediment and Storm Water Inspector™ (CESSWI)	Enviro Cert International Inc.	QSP	1. Approval Process 2. Code of Ethics 3. Accountability 4. Pre-requisites 5. Continuing Education
Certified Professional in Storm Water Quality™ (CPSWQ)	Enviro Cert International Inc.	Both	1. Approval Process 2. Code of Ethics 3. Accountability 4. Pre-requisites 5. Continuing Education

The previous versions of the General Permit required development and implementation of a SWPPP as the primary compliance mechanism. The SWPPP has two major objectives: (1) to help identify the sources of sediment and other pollutants that affect the quality of storm water discharges; and (2) to describe and ensure the implementation of BMPs to reduce or eliminate sediment and other pollutants in storm water and non-storm water discharges. The SWPPP must include BMPs that address source control, BMPs that address pollutant control, and BMPs that address treatment control.

This General Permit shifts some of the measures that were covered by this general requirement to specific permit requirements, each individually enforceable as a permit term. This General Permit emphasizes the use of appropriately selected, correctly installed and maintained pollution reduction BMPs. This approach provides the flexibility necessary to establish BMPs that can effectively address source control of pollutants during changing construction activities. These specific requirements also improve both the clarity and the enforceability of the General Permit so that the dischargers understand, and the public can determine whether the discharges are in compliance with, permit requirements.

The SWPPP must be implemented at the appropriate level to protect water quality at all times throughout the life of the project. The SWPPP must remain on the site during construction activities, commencing with the initial mobilization and ending with the termination of coverage under the General Permit. For LUPs the discharger shall make the SWPPP available at the construction site during working hours while construction is occurring and shall be made available upon request by a State or Municipal inspector. When the original SWPPP is retained by a crewmember in a construction vehicle and is not currently at the construction site, current copies of the BMPs and map/drawing will be left with the field crew and the original SWPPP shall be made available via a request by radio or telephone. Once construction activities are complete, until stabilization is achieved, the SWPPP shall be available from the SWPPP contact listed in the PRDs

A SWPPP must be appropriate for the type and complexity of a project and will be developed and implemented to address project specific conditions. Some projects may have similarities or complexities, yet each project is unique in its progressive state that requires specific description and selection of BMPs needed to address all possible generated pollutants

N. Regional Water Board Authorities

Because this General Permit will be issued to thousands of construction sites across the State, the Regional Water Boards retain discretionary authority over certain issues that may arise from the discharges in their respective regions. This General Permit does not grant the Regional Water Boards any authority they do not otherwise have; rather, it merely emphasizes that the Regional Water Boards can take specific actions related to this General Permit. For example, the Regional Water Boards will be enforcing this General Permit and may need to adjust some requirements for a discharger based on the discharger's compliance history.



Linda S. Adams
Secretary for
Environmental Protection

State Water Resources Control Board



Arnold Schwarzenegger
Governor

Division of Water Quality

1001 I Street • Sacramento, California 95814 • (916) 341-5455
Mailing Address: P.O. Box 100 • Sacramento, California • 95812-0100
Fax (916) 341-5463 • <http://www.waterboards.ca.gov>

NATIONAL POLLUTANT DISCHARGE ELIMINATION SYSTEM (NPDES)
GENERAL PERMIT FOR
STORM WATER DISCHARGES
ASSOCIATED WITH CONSTRUCTION AND LAND DISTURBANCE
ACTIVITIES

ORDER NO. 2009-0009-DWQ
NPDES NO. **CAS000002**

This Order was adopted by the State Water Resources Control Board on:	September 2, 2009
This Order shall become effective on:	July 1, 2010
This Order shall expire on:	September 2, 2014

IT IS HEREBY ORDERED, that this Order supersedes Order No. 99-08-DWQ [as amended by Order No. 2010-0014-DWQ] except for enforcement purposes. The Discharger shall comply with the requirements in this Order to meet the provisions contained in Division 7 of the California Water Code (commencing with section 13000) and regulations adopted thereunder, and the provisions of the federal Clean Water Act and regulations and guidelines adopted thereunder.

I, Jeanine Townsend, Clerk to the Board, do hereby certify that this Order with all attachments is a full, true, and correct copy of an Order adopted by the State Water Resources Control Board, on September 2, 2009.

AYE: Vice Chair Frances Spivy-Weber
Board Member Arthur G. Baggett, Jr.
Board Member Tam M. Doduc

NAY: Chairman Charles R. Hoppin

ABSENT: None

ABSTAIN: None

Jeanine Townsend
Clerk to the Board



Linda S. Adams
Secretary for
Environmental Protection

State Water Resources Control Board



Arnold Schwarzenegger
Governor

Division of Water Quality

1001 I Street • Sacramento, California 95814 • (916) 341-5455
Mailing Address: P.O. Box 100 • Sacramento, California • 95812-0100
Fax (916) 341-5463 • <http://www.waterboards.ca.gov>

NATIONAL POLLUTANT DISCHARGE ELIMINATION SYSTEM (NPDES) GENERAL PERMIT FOR STORM WATER DISCHARGES ASSOCIATED WITH CONSTRUCTION AND LAND DISTURBANCE ACTIVITIES

**ORDER NO. 2010-0014-DWQ
NPDES NO. CAS000002**

Order No. 2009-0009-DWQ was adopted by the State Water Resources Control Board on:	September 2, 2009
Order No. 2009-0009-DWQ became effective on:	July 1, 2010
Order No. 2009-0009-DWQ shall expire on:	September 2, 2014
This Order, which amends Order No. 2009-0009-DWQ, was adopted by the State Water Resources Control Board on:	November 16, 2010
This Order shall become effective on:	February 14, 2011

IT IS HEREBY ORDERED that this Order amends Order No. 2009-0009-DWQ. Additions to Order No. 2009-0009-DWQ are reflected in [blue-underline](#) text and deletions are reflected in ~~red-strikeout~~ text.

IT IS FURTHER ORDERED that staff are directed to prepare and post a conformed copy of Order No. 2009-0009-DWQ incorporating the revisions made by this Order.

I, Jeanine Townsend, Clerk to the Board, do hereby certify that this Order with all attachments is a full, true, and correct copy of an Order adopted by the State Water Resources Control Board, on **November 16, 2010**.

AYE: Chairman Charles R. Hoppin
Vice Chair Frances Spivy-Weber
Board Member Arthur G. Baggett, Jr.
Board Member Tam M. Doduc

NAY: None

ABSENT: None

ABSTAIN: None

Jeanine Townsend
Clerk to the Board

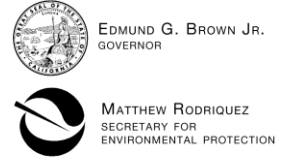

State Water Resources Control Board

NATIONAL POLLUTANT DISCHARGE ELIMINATION SYSTEM (NPDES)
GENERAL PERMIT FOR
STORM WATER DISCHARGES
ASSOCIATED WITH CONSTRUCTION AND LAND DISTURBANCE ACTIVITIES

ORDER NO. 2012-0006-DWQ
NPDES NO. CAS000002

Table with 2 columns: Description of order changes and Effective dates. Rows include adoption of 2009-0009-DWQ, effectiveness dates for 2009-0009-DWQ, 2010-0014-DWQ, expiration of 2009-0009-DWQ as amended, adoption of the current order, and its effectiveness date.

IT IS HEREBY ORDERED that this Order amends Order No. 2009-0009-DWQ. Additions to Order No. 2009-0009-DWQ are reflected in blue-underline text and deletions are reflected in red-strikeout text.

IT IS FURTHER ORDERED that staff are directed to prepare and post a conformed copy of Order No. 2009-000-DWQ incorporating the revisions made by this Order.

I, Jeanine Townsend, Clerk to the Board, do hereby certify that this Order with all attachments is a full, true, and correct copy of an Order adopted by the State Water Resources Control Board, on July 17, 2012.

AYE: Chairman Charles R. Hoppin
Vice Chair Frances Spivy-Weber
Board Member Tam M. Doduc
Board Member Steven Moore
Board Member Felicia Marcus

NAY: None

ABSENT: None

ABSTAIN: None

Handwritten signature of Jeanine Townsend
Jeanine Townsend
Clerk to the Board

TABLE OF CONTENTS

I.	FINDINGS	1
II.	CONDITIONS FOR PERMIT COVERAGE.....	14
III.	DISCHARGE PROHIBITIONS.....	20
IV.	SPECIAL PROVISIONS.....	22
V.	EFFLUENT STANDARDS & RECEIVING WATER MONITORING.....	28
VI.	RECEIVING WATER LIMITATIONS	31
VII.	TRAINING QUALIFICATIONS AND CERTIFICATION REQUIREMENTS.....	32
VIII.	RISK DETERMINATION	33
IX.	RISK LEVEL 1 REQUIREMENTS.....	34
X.	RISK LEVEL 2 REQUIREMENTS.....	34
XI.	RISK LEVEL 3 REQUIREMENTS.....	34
XII.	ACTIVE TREATMENT SYSTEMS (ATS).....	34
XIII.	POST-CONSTRUCTION STANDARDS	35
XIV.	SWPPP REQUIREMENTS	37
XV.	REGIONAL WATER BOARD AUTHORITIES.....	38
XVI.	ANNUAL REPORTING REQUIREMENTS.....	39

LIST OF ATTACHMENTS

Attachment A – Linear Underground/Overhead Requirements
Attachment A.1 – LUP Type Determination
Attachment A.2 – LUP Permit Registration Documents
Attachment B – Permit Registration Documents
Attachment C – Risk Level 1 Requirements
Attachment D – Risk Level 2 Requirements
Attachment E – Risk Level 3 Requirements
Attachment F – Active Treatment System (ATS) Requirements

LIST OF APPENDICES

Appendix 1 – Risk Determination Worksheet
Appendix 2 – Post-Construction Water Balance Performance Standard
Appendix 2.1 – Post-Construction Water Balance Performance Standard Spreadsheet
Appendix 3 – Bioassessment Monitoring Guidelines
Appendix 4 – Adopted/Implemented Sediment TMDLs
Appendix 5 – Glossary
Appendix 6 – Acronyms
Appendix 7 – State and Regional Water Resources Control Board Contacts

**STATE WATER RESOURCES CONTROL BOARD
ORDER NO. 2009-0009-DWQ
[AS AMENDED BY ORDER NO. 2010-0014-DWQ]
NATIONAL POLLUTANT DISCHARGE ELIMINATION SYSTEM
GENERAL PERMIT NO. CAS000002**

**WASTE DISCHARGE REQUIREMENTS
FOR
DISCHARGES OF STORM WATER RUNOFF ASSOCIATED WITH
CONSTRUCTION AND LAND DISTURBANCE ACTIVITIES**

I. FINDINGS

A. General Findings

The State Water Resources Control Board (State Water Board) finds that:

1. The federal Clean Water Act (CWA) prohibits certain discharges of storm water containing pollutants except in compliance with a National Pollutant Discharge Elimination System (NPDES) permit (Title 33 United States Code (U.S.C.) §§ 1311 and 1342(p); also referred to as Clean Water Act (CWA) §§ 301 and 402(p)). The U.S. Environmental Protection Agency (U.S. EPA) promulgates federal regulations to implement the CWA's mandate to control pollutants in storm water runoff discharges. (Title 40 Code of Federal Regulations (C.F.R.) Parts 122, 123, and 124). The federal statutes and regulations require discharges to surface waters comprised of storm water associated with construction activity, including demolition, clearing, grading, and excavation, and other land disturbance activities (except operations that result in disturbance of less than one acre of total land area and which are not part of a larger common plan of development or sale), to obtain coverage under an NPDES permit. The NPDES permit must require implementation of Best Available Technology Economically Achievable (BAT) and Best Conventional Pollutant Control Technology (BCT) to reduce or eliminate pollutants in storm water runoff. The NPDES permit must also include additional requirements necessary to implement applicable water quality standards.
2. This General Permit authorizes discharges of storm water associated with construction activity so long as the dischargers comply with all requirements, provisions, limitations and prohibitions in the permit. In addition, this General Permit regulates the discharges of storm water associated with construction activities from all Linear

Underground/Overhead Projects resulting in the disturbance of greater than or equal to one acre (Attachment A).

3. This General Permit regulates discharges of pollutants in storm water associated with construction activity (storm water discharges) to waters of the United States from construction sites that disturb one or more acres of land surface, or that are part of a common plan of development or sale that disturbs more than one acre of land surface.
4. This General Permit does not preempt or supersede the authority of local storm water management agencies to prohibit, restrict, or control storm water discharges to municipal separate storm sewer systems or other watercourses within their jurisdictions.
5. This action to adopt a general NPDES permit is exempt from the provisions of Chapter 3 of the California Environmental Quality Act (CEQA) (Public Resources Code Section 21100, et seq.), pursuant to Section 13389 of the California Water Code.
6. Pursuant to 40 C.F.R. § 131.12 and State Water Board [Resolution No. 68-16](#),¹ which incorporates the requirements of § 131.12 where applicable, the State Water Board finds that discharges in compliance with this General Permit will not result in the lowering of water quality standards, and are therefore consistent with those provisions. Compliance with this General Permit will result in improvements in water quality.
7. This General Permit serves as an NPDES permit in compliance with CWA § 402 and will take effect on July 1, 2010 by the State Water Board provided the Regional Administrator of the U.S. EPA has no objection. If the U.S. EPA Regional Administrator objects to its issuance, the General Permit will not become effective until such objection is withdrawn.
8. Following adoption and upon the effective date of this General Permit, the Regional Water Quality Control Boards (Regional Water Boards) shall enforce the provisions herein.
9. Regional Water Boards establish water quality standards in Basin Plans. The State Water Board establishes water quality standards in various statewide plans, including the California Ocean Plan. U.S. EPA establishes water quality standards in the National Toxic Rule (NTR) and the California Toxic Rule (CTR).

¹ Resolution No. 68-16 generally requires that existing water quality be maintained unless degradation is justified based on specific findings.

10. This General Permit does not authorize discharges of fill or dredged material regulated by the U.S. Army Corps of Engineers under CWA § 404 and does not constitute a waiver of water quality certification under CWA § 401.
11. The primary storm water pollutant at construction sites is excess sediment. Excess sediment can cloud the water, which reduces the amount of sunlight reaching aquatic plants, clog fish gills, smother aquatic habitat and spawning areas, and impede navigation in our waterways. Sediment also transports other pollutants such as nutrients, metals, and oils and greases.
12. Construction activities can impact a construction site's runoff sediment supply and transport characteristics. These modifications, which can occur both during and after the construction phase, are a significant cause of degradation of the beneficial uses established for water bodies in California. Dischargers can avoid these effects through better construction site design and activity practices.
13. This General Permit recognizes four distinct phases of construction activities. The phases are Grading and Land Development Phase, Streets and Utilities Phase, Vertical Construction Phase, and Final Landscaping and Site Stabilization Phase. Each phase has activities that can result in different water quality effects from different water quality pollutants. This General Permit also recognizes inactive construction as a category of construction site type.
14. Compliance with any specific limits or requirements contained in this General Permit does not constitute compliance with any other applicable requirements.
15. Following public notice in accordance with State and Federal laws and regulations, the State Water Board heard and considered all comments and testimony in a public hearing on 06/03/2009. The State Water Board has prepared written responses to all significant comments.
16. Construction activities obtaining coverage under the General Permit may have multiple discharges subject to requirements that are specific to general, linear, and/or active treatment system discharge types.
17. The State Water Board may reopen the permit if the U.S. EPA adopts a final effluent limitation guideline for construction activities.

B. Activities Covered Under the General Permit

18. Any construction or demolition activity, including, but not limited to, clearing, grading, grubbing, or excavation, or any other activity that results in a land disturbance of equal to or greater than one acre.
19. Construction activity that results in land surface disturbances of less than one acre if the construction activity is part of a larger common plan of development or the sale of one or more acres of disturbed land surface.
20. Construction activity related to residential, commercial, or industrial development on lands currently used for agriculture including, but not limited to, the construction of buildings related to agriculture that are considered industrial pursuant to U.S. EPA regulations, such as dairy barns or food processing facilities.
21. Construction activity associated with Linear Underground/Overhead Utility Projects (LUPs) including, but not limited to, those activities necessary for the installation of underground and overhead linear facilities (e.g., conduits, substructures, pipelines, towers, poles, cables, wires, connectors, switching, regulating and transforming equipment and associated ancillary facilities) and include, but are not limited to, underground utility mark-out, potholing, concrete and asphalt cutting and removal, trenching, excavation, boring and drilling, access road and pole/tower pad and cable/wire pull station, substation construction, substructure installation, construction of tower footings and/or foundations, pole and tower installations, pipeline installations, welding, concrete and/or pavement repair or replacement, and stockpile/borrow locations.
22. Discharges of sediment from construction activities associated with oil and gas exploration, production, processing, or treatment operations or transmission facilities.²
23. Storm water discharges from dredge spoil placement that occur outside of U.S. Army Corps of Engineers jurisdiction (upland sites) and that disturb one or more acres of land surface from construction activity are covered by this General Permit. Construction sites that intend to disturb one or more acres of land within the jurisdictional boundaries of

² Pursuant to the Ninth Circuit Court of Appeals' decision in *NRDC v. EPA* (9th Cir. 2008) 526 F.3d 591, and subsequent denial of the U.S. EPA's petition for reconsideration in November 2008, oil and gas construction activities discharging storm water contaminated only with sediment are no longer exempt from the NPDES program.

a CWA § 404 permit should contact the appropriate Regional Water Board to determine whether this permit applies to the site.

C. Activities Not Covered Under the General Permit

24. Routine maintenance to maintain original line and grade, hydraulic capacity, or original purpose of the facility.
25. Disturbances to land surfaces solely related to agricultural operations such as disking, harrowing, terracing and leveling, and soil preparation.
26. Discharges of storm water from areas on tribal lands; construction on tribal lands is regulated by a federal permit.
27. Construction activity and land disturbance involving discharges of storm water within the Lake Tahoe Hydrologic Unit. The Lahontan Regional Water Board has adopted its own permit to regulate storm water discharges from construction activity in the Lake Tahoe Hydrologic Unit (Regional Water Board 6SLT). Owners of construction sites in this watershed must apply for the Lahontan Regional Water Board permit rather than the statewide Construction General Permit.
28. Construction activity that disturbs less than one acre of land surface, and that is not part of a larger common plan of development or the sale of one or more acres of disturbed land surface.
29. Construction activity covered by an individual NPDES Permit for storm water discharges.
30. Discharges from small (1 to 5 acre) construction activities with an approved Rainfall Erosivity Waiver authorized by U.S. EPA Phase II regulations certifying to the State Board that small construction activity will occur only when the Rainfall Erosivity Factor is less than 5 ("R" in the Revised Universal Soil Loss Equation).
31. Landfill construction activity that is subject to the Industrial General Permit.
32. Construction activity that discharges to Combined Sewer Systems.
33. Conveyances that discharge storm water runoff combined with municipal sewage.
34. Discharges of storm water identified in CWA § 402(l)(2), 33 U.S.C. § 1342(l)(2).

35. Discharges occurring in basins that are not tributary or hydrologically connected to waters of the United States (for more information contact your Regional Water Board).

D. Obtaining and Modifying General Permit Coverage

36. This General Permit requires all dischargers to electronically file all Permit Registration Documents (PRDs), Notices of Termination (NOT), changes of information, annual reporting, and other compliance documents required by this General Permit through the State Water Board's Storm water Multi-Application and Report Tracking System (SMARTS) website.
37. Any information provided to the Regional Water Board shall comply with the Homeland Security Act and any other federal law that concerns security in the United States; any information that does not comply should not be submitted.
38. This General Permit grants an exception from the Risk Determination requirements for existing sites covered under Water Quality Orders No. 99-08-DWQ, and [No. 2003-0007-DWQ](#). For certain sites, adding additional requirements may not be cost effective. Construction sites covered under Water Quality Order No. 99-08-DWQ shall obtain permit coverage at the Risk Level 1. LUPs covered under Water Quality Order No. 2003-0007-DWQ shall obtain permit coverage as a Type 1 LUP. The Regional Water Boards have the authority to require Risk Determination to be performed on sites currently covered under Water Quality Orders No. 99-08-DWQ and No. 2003-0007-DWQ where they deem it necessary. The State Water Board finds that there are two circumstances when it may be appropriate for the Regional Water Boards to require a discharger that had filed an NOI under State Water Board Order No. 99-08-DWQ to recalculate the site's risk level. These circumstances are: (1) when the discharger has a demonstrated history of noncompliance with State Water Board Order No. 99-08-DWQ or; (2) when the discharger's site poses a significant risk of causing or contributing to an exceedance of a water quality standard without the implementation of the additional Risk Level 2 or 3 requirements.

E. Prohibitions

39. All discharges are prohibited except for the storm water and non-storm water discharges specifically authorized by this General Permit or another NPDES permit. Non-storm water discharges include a wide variety of sources, including improper dumping, spills, or leakage from storage tanks or transfer areas. Non-storm water discharges may

contribute significant pollutant loads to receiving waters. Measures to control spills, leakage, and dumping, and to prevent illicit connections during construction must be addressed through structural as well as non-structural Best Management Practices (BMPs)³. The State Water Board recognizes, however, that certain non-storm water discharges may be necessary for the completion of construction.

40. This General Permit prohibits all discharges which contain a hazardous substance in excess of reportable quantities established in 40 C.F.R. §§ 117.3 and 302.4, unless a separate NPDES Permit has been issued to regulate those discharges.
41. This General Permit incorporates discharge prohibitions contained in water quality control plans, as implemented by the State Water Board and the nine Regional Water Boards.
42. Pursuant to the Ocean Plan, discharges to Areas of Special Biological Significance (ASBS) are prohibited unless covered by an exception that the State Water Board has approved.
43. This General Permit prohibits the discharge of any debris⁴ from construction sites. Plastic and other trash materials can cause negative impacts to receiving water beneficial uses. The State Water Board encourages the use of more environmentally safe, biodegradable materials on construction sites to minimize the potential risk to water quality.

F. Training

44. In order to improve compliance with and to maintain consistent enforcement of this General Permit, all dischargers are required to appoint two positions - the Qualified SWPPP Developer (QSD) and the Qualified SWPPP Practitioner (QSP) - who must obtain appropriate training. Together with the key stakeholders, the State and Regional Water Boards are leading the development of this curriculum through a collaborative organization called The Construction General Permit (CGP) Training Team.
45. The Professional Engineers Act (Bus. & Prof. Code section 6700, et seq.) requires that all engineering work must be performed by a California licensed engineer.

³ BMPs are scheduling of activities, prohibitions of practices, maintenance procedures, and other management practices to prevent or reduce the discharge of pollutants to waters of the United States. BMPs also include treatment requirements, operating procedures, and practice to control site runoff, spillage or leaks, sludge or waste disposal, or drainage from raw material storage.

⁴ Litter, rubble, discarded refuse, and remains of destroyed inorganic anthropogenic waste.

G. Determining and Reducing Risk

46. The risk of accelerated erosion and sedimentation from wind and water depends on a number of factors, including proximity to receiving water bodies, climate, topography, and soil type.
47. This General Permit requires dischargers to assess the risk level of a site based on both sediment transport and receiving water risk. This General Permit contains requirements for Risk Levels 1, 2 and 3, and LUP Risk Type 1, 2, and 3 (Attachment A). Risk levels are established by determining two factors: first, calculating the site's sediment risk; and second, receiving water risk during periods of soil exposure (i.e. grading and site stabilization). Both factors are used to determine the site-specific Risk Level(s). LUPs can be determined to be Type 1 based on the flowchart in Attachment A.1.
48. Although this General Permit does not mandate specific setback distances, dischargers are encouraged to set back their construction activities from streams and wetlands whenever feasible to reduce the risk of impacting water quality (e.g., natural stream stability and habitat function). Because there is a reduced risk to receiving waters when setbacks are used, this General Permit gives credit to setbacks in the risk determination and post-construction storm water performance standards. The risk calculation and runoff reduction mechanisms in this General Permit are expected to facilitate compliance with any Regional Water Board and local agency setback requirements, and to encourage voluntary setbacks wherever practicable.
49. Rain events can occur at any time of the year in California. Therefore, a Rain Event Action Plan (REAP) is necessary for Risk Level 2 and 3 traditional construction projects (LUPs exempt) to ensure that active construction sites have adequate erosion and sediment controls implemented prior to the onset of a storm event, even if construction is planned only during the dry season.
50. Soil particles smaller than 0.02 millimeters (mm) (i.e., finer than medium silt) do not settle easily using conventional measures for sediment control (i.e., sediment basins). Given their long settling time, dislodging these soils results in a significant risk that fine particles will be released into surface waters and cause unacceptable downstream impacts. If operated correctly, an Active Treatment System (ATS⁵) can prevent or reduce the release of fine particles from construction sites.

⁵ An ATS is a treatment system that employs chemical coagulation, chemical flocculation, or electro coagulation in order to reduce turbidity caused by fine suspended sediment.

Use of an ATS can effectively reduce a site's risk of impacting receiving waters.

51. Dischargers located in a watershed area where a Total Maximum Daily Load (TMDL) has been adopted or approved by the Regional Water Board or U.S. EPA may be required by a separate Regional Water Board action to implement additional BMPs, conduct additional monitoring activities, and/or comply with an applicable waste load allocation and implementation schedule. Such dischargers may also be required to obtain an individual Regional Water Board permit specific to the area.

H. Effluent Standards

52. The State Water Board convened a blue ribbon panel of storm water experts that submitted a report entitled, "The Feasibility of Numeric Effluent Limits Applicable to Discharges of Storm Water Associated with Municipal, Industrial and Construction Activities," dated June 19, 2006. The panel concluded that numeric limits or action levels are technically feasible to control construction storm water discharges, provided that certain conditions are considered. The panel also concluded that numeric effluent limitations (NELs) are feasible for discharges from construction sites that utilize an ATS. The State Water Board has incorporated the expert panel's suggestions into this General Permit, which includes numeric action levels (NALs) for pH and turbidity, and special numeric limits for ATS discharges.

Determining Compliance with Numeric Limitations

53. This General Permit sets a pH NAL of 6.5 to 8.5, and a turbidity NAL of 250 NTU. The purpose of the NAL and its associated monitoring requirement is to provide operational information regarding the performance of the measures used at the site to minimize the discharge of pollutants and to protect beneficial uses and receiving waters from the adverse effects of construction-related storm water discharges. An exceedance of a NAL does not constitute a violation of this General Permit.
54. This General Permit requires dischargers with NAL exceedances to immediately implement additional BMPs and revise their Storm Water Pollution Prevention Plans (SWPPPs) accordingly to either prevent pollutants and authorized non-storm water discharges from contaminating storm water, or to substantially reduce the pollutants to levels consistently below the NALs. NAL exceedances are reported in the State Water Boards SMARTS system, and the discharger is

required to provide an NAL Exceedance Report when requested by a Regional Water Board.

I. Receiving Water Limitations

55. This General Permit requires all enrolled dischargers to determine the receiving waters potentially affected by their discharges and to comply with all applicable water quality standards, including any more stringent standards applicable to a water body.

J. Sampling, Monitoring, Reporting and Record Keeping

56. Visual monitoring of storm water and non-storm water discharges is required for all sites subject to this General Permit.

57. Records of all visual monitoring inspections are required to remain on-site during the construction period and for a minimum of three years.

58. For all Risk Level 3/LUP Type 3 and Risk Level 2/LUP Type 2 sites, this General Permit requires effluent monitoring for pH and turbidity. Sampling, analysis and monitoring requirements for effluent monitoring for pH and turbidity are contained in this General Permit.

59. Risk Level 3 and LUP Type 3 sites with effluent that exceeds the Receiving Water Monitoring Triggers contained in this General Permit and with direct discharges to receiving water are required to conduct receiving water monitoring. An exceedance of a Receiving Water Monitoring Trigger does not constitute a violation of this General Permit.

60. This General Permit establishes a 5 year, 24 hour (expressed in inches of rainfall) as an exemptions to the receiving water monitoring requirements for Risk Level 3 and LUP Type 3 dischargers.

61. If run-on is caused by a forest fire or any other natural disaster, then receiving water monitoring triggers do not apply.

62. For Risk Level 3 and LUP Type 3 sites larger than 30 acres and with direct discharges to receiving waters, this General Permit requires bioassessment sampling before and after site completion to determine if significant degradation to the receiving water's biota has occurred. Bioassessment sampling guidelines are contained in this General Permit.

63. A summary and evaluation of the sampling and analysis results will be submitted in the Annual Reports.
64. This General Permit contains sampling, analysis and monitoring requirements for non-visible pollutants at all sites subject to this General Permit.
65. Compliance with the General Permit relies upon dischargers to electronically self-report any discharge violations and to comply with any Regional Water Board enforcement actions.
66. This General Permit requires that all dischargers maintain a paper or electronic copy of all required records for three years from the date generated or date submitted, whichever is last. These records must be available at the construction site until construction is completed. For LUPs, these documents may be retained in a crew member's vehicle and made available upon request.

K. Active Treatment System (ATS) Requirements

67. Active treatment systems add chemicals to facilitate flocculation, coagulation and filtration of suspended sediment particles. The uncontrolled release of these chemicals to the environment can negatively affect the beneficial uses of receiving waters and/or degrade water quality (e.g., acute and chronic toxicity). Additionally, the batch storage and treatment of storm water through an ATS' can potentially cause physical impacts on receiving waters if storage volume is inadequate or due to sudden releases of the ATS batches and improperly designed outfalls.
68. If designed, operated and maintained properly an ATS can achieve very high removal rates of suspended sediment (measured as turbidity), albeit at sometimes significantly higher costs than traditional erosion/sediment control practices. As a result, this General Permit establishes NELs consistent with the expected level of typical ATS performance.
69. This General Permit requires discharges of storm water associated with construction activity that undergo active treatment to comply with special operational and effluent limitations to ensure that these discharges do not adversely affect the beneficial uses of the receiving waters or cause degradation of their water quality.
70. For ATS discharges, this General Permit establishes technology-based NELs for turbidity.

71. This General Permit establishes a 10 year, 24 hour (expressed in inches of rainfall) Compliance Storm Event exemption from the technology-based numeric effluent limitations for ATS discharges. Exceedances of the ATS turbidity NEL constitutes a violation of this General Permit.

L. Post-Construction Requirements

72. This General Permit includes performance standards for post-construction that are consistent with State Water Board [Resolution No. 2005-0006](#), "Resolution Adopting the Concept of Sustainability as a Core Value for State Water Board Programs and Directing Its Incorporation," and [2008-0030](#), "Requiring Sustainable Water Resources Management." The requirement for all construction sites to match pre-project hydrology will help ensure that the physical and biological integrity of aquatic ecosystems are sustained. This "runoff reduction" approach is analogous in principle to Low Impact Development (LID) and will serve to protect related watersheds and waterbodies from both hydrologic-based and pollution impacts associated with the post-construction landscape.
73. LUP projects are not subject to post-construction requirements due to the nature of their construction to return project sites to pre-construction conditions.

M. Storm Water Pollution Prevention Plan Requirements

74. This General Permit requires the development of a site-specific SWPPP. The SWPPP must include the information needed to demonstrate compliance with all requirements of this General Permit, and must be kept on the construction site and be available for review. The discharger shall ensure that a QSD develops the SWPPP.
75. To ensure proper site oversight, this General Permit requires a Qualified SWPPP Practitioner to oversee implementation of the BMPs required to comply with this General Permit.

N. Regional Water Board Authorities

76. Regional Water Boards are responsible for implementation and enforcement of this General Permit. A general approach to permitting is not always suitable for every construction site and environmental circumstances. Therefore, this General Permit recognizes that Regional Water Boards must have some flexibility and authority to alter, approve, exempt, or rescind permit authority granted under this

General Permit in order to protect the beneficial uses of our receiving waters and prevent degradation of water quality.

IT IS HEREBY ORDERED that all dischargers subject to this General Permit shall comply with the following conditions and requirements (including all conditions and requirements as set forth in Attachments A, B, C, D, E and F)⁶:

II. CONDITIONS FOR PERMIT COVERAGE

A. Linear Underground/Overhead Projects (LUPs)

1. Linear Underground/Overhead Projects (LUPs) include, but are not limited to, any conveyance, pipe, or pipeline for the transportation of any gaseous, liquid (including water and wastewater for domestic municipal services), liquescent, or slurry substance; any cable line or wire for the transmission of electrical energy; any cable line or wire for communications (e.g. telephone, telegraph, radio or television messages); and associated ancillary facilities. Construction activities associated with LUPs include, but are not limited to, (a) those activities necessary for the installation of underground and overhead linear facilities (e.g., conduits, substructures, pipelines, towers, poles, cables, wires, connectors, switching, regulating and transforming equipment, and associated ancillary facilities); and include, but are not limited to, (b) underground utility mark-out, potholing, concrete and asphalt cutting and removal, trenching, excavation, boring and drilling, access road and pole/tower pad and cable/wire pull station, substation construction, substructure installation, construction of tower footings and/or foundations, pole and tower installations, pipeline installations, welding, concrete and/ or pavement repair or replacement, and stockpile/borrow locations.
2. The Legally Responsible Person is responsible for obtaining coverage under the General Permit where the construction of pipelines, utility lines, fiber-optic cables, or other linear underground/overhead projects will occur across several properties unless the LUP construction activities are covered under another construction storm water permit.
3. Only LUPs shall comply with the conditions and requirements in Attachment A, A.1 & A.2 of this Order. The balance of this Order is not applicable to LUPs except as indicated in Attachment A.

⁶ These attachments are part of the General Permit itself and are not separate documents that are capable of being updated independently by the State Water Board.

B. Obtaining Permit Coverage Traditional Construction Sites

1. The Legally Responsible Person (LRP) (see Special Provisions, Electronic Signature and Certification Requirements, Section IV.I.1) must obtain coverage under this General Permit.
2. To obtain coverage, the LRP must electronically file Permit Registration Documents (PRDs) prior to the commencement of construction activity. Failure to obtain coverage under this General Permit for storm water discharges to waters of the United States is a violation of the CWA and the California Water Code.
3. PRDs shall consist of:
 - a. Notice of Intent (NOI)
 - b. Risk Assessment (Section VIII)
 - c. Site Map
 - d. Storm Water Pollution Prevention Plan (Section XIV)
 - e. Annual Fee
 - f. Signed Certification Statement

Any information provided to the Regional Water Board shall comply with the Homeland Security Act and any other federal law that concerns security in the United States; any information that does not comply should not be submitted.

Attachment B contains additional PRD information. Dischargers must electronically file the PRDs, and mail the appropriate annual fee to the State Water Board.

4. This permit is effective on July 1, 2010.
 - a. **Dischargers Obtaining Coverage On or After July 1, 2010:** All dischargers requiring coverage on or after July 1, 2010, shall electronically file their PRDs prior to the commencement of construction activities, and mail the appropriate annual fee no later than seven days prior to the commencement of construction activities. Permit coverage shall not commence until the PRDs and the annual fee are received by the State Water Board, and a WDID number is assigned and sent by SMARTS.
 - b. **Dischargers Covered Under 99-08-DWQ and 2003-0007-DWQ:** Existing dischargers subject to State Water Board Order No. 99-08-DWQ (existing dischargers) will continue coverage under 99-08-DWQ until July 1, 2010. After July 1, 2010, all NOIs subject to State Water Board Order No. 99-08-DWQ will be terminated.

Existing dischargers shall electronically file their PRDs no later than July 1, 2010. If an existing discharger's site acreage subject to the annual fee has changed, it shall mail a revised annual fee no less than seven days after receiving the revised annual fee notification, **or else lose permit coverage**. All existing dischargers shall be exempt from the risk determination requirements in Section VIII of this General Permit until two years after permit adoption. All existing dischargers are therefore subject to Risk Level 1 requirements regardless of their site's sediment and receiving water risks. However, a Regional Board retains the authority to require an existing discharger to comply with the Section VIII risk determination requirements.

5. The discharger is only considered covered by this General Permit upon receipt of a Waste Discharger Identification (WDID) number assigned and sent by the State Water Board Storm water Multi-Application and Report Tracking System (SMARTS). In order to demonstrate compliance with this General Permit, the discharger must obtain a WDID number and must present documentation of a valid WDID upon demand.
6. During the period this permit is subject to review by the U.S. EPA, the prior permit (State Water Board Order No. 99-08-DWQ) remains in effect. Existing dischargers under the prior permit will continue to have coverage under State Water Board Order No. 99-08-DWQ until this General Permit takes effect on July 1, 2010. Dischargers who complete their projects and electronically file an NOT prior to July 1, 2010, are not required to obtain coverage under this General Permit.
7. Small Construction Rainfall Erosivity Waiver

EPA's Small Construction Erosivity Waiver applies to sites between one and five acres demonstrating that there are no adverse water quality impacts.

Dischargers eligible for a Rainfall Erosivity Waiver based on low erosivity potential shall complete the electronic Notice of Intent (NOI) and Sediment Risk form through the State Water Board's SMARTS system, certifying that the construction activity will take place during a period when the value of the rainfall erosivity factor is less than five. Where the LRP changes or another LRP is added during construction, the new LRP must also submit a waiver certification through the SMARTS system.

If a small construction site continues beyond the projected completion date given on the waiver certification, the LRP shall recalculate the

rainfall erosivity factor for the new project duration and submit this information through the SMARTS system. If the new R factor is below five (5), the discharger shall update through SMARTS all applicable information on the waiver certification and retain a copy of the revised waiver onsite. The LRP shall submit the new waiver certification 30 days prior to the projected completion date listed on the original waiver form to assure exemption from permitting requirements is uninterrupted. If the new R factor is five (5) or above, the LRP shall be required to apply for coverage under this Order.

8. In the case of a public emergency that requires immediate construction activities, a discharger shall submit a brief description of the emergency construction activity within five days of the onset of construction, and then shall submit all PRDs within thirty days.

C. Revising Permit Coverage for Change of Acreage or New Ownership

1. The discharger may reduce or increase the total acreage covered under this General Permit when a portion of the site is complete and/or conditions for termination of coverage have been met (See Section II.D Conditions for Termination of Coverage); when ownership of a portion of the site is sold to a different entity; or when new acreage, subject to this General Permit, is added to the site.
2. Within 30 days of a reduction or increase in total disturbed acreage, the discharger shall electronically file revisions to the PRDs that include:
 - a. A revised NOI indicating the new project size;
 - b. A revised site map showing the acreage of the site completed, acreage currently under construction, acreage sold/transferred or added, and acreage currently stabilized in accordance with the Conditions for Termination of Coverage in Section II.D below.
 - c. SWPPP revisions, as appropriate; and
 - d. Certification that any new landowners have been notified of applicable requirements to obtain General Permit coverage. The certification shall include the name, address, telephone number, and e-mail address of the new landowner.
 - e. If the project acreage has increased, dischargers shall mail payment of revised annual fees within 14 days of receiving the revised annual fee notification.

3. The discharger shall continue coverage under the General Permit for any parcel that has not achieved “Final Stabilization” as defined in Section II.D.
4. When an LRP with active General Permit coverage transfers its LRP status to another person or entity that qualifies as an LRP, the existing LRP shall inform the new LRP of the General Permit’s requirements. In order for the new LRP to continue the construction activity on its parcel of property, the new LRP, or the new LRP’s approved signatory, must submit PRDs in accordance with this General Permit’s requirements.

D. Conditions for Termination of Coverage

1. Within 90 days of when construction is complete or ownership has been transferred, the discharger shall electronically file a Notice of Termination (NOT), a final site map, and photos through the State Water Boards SMARTS system. Filing a NOT certifies that all General Permit requirements have been met. The Regional Water Board will consider a construction site complete only when all portions of the site have been transferred to a new owner, or all of the following conditions have been met:
 - a. For purposes of “final stabilization,” the site will not pose any additional sediment discharge risk than it did prior to the commencement of construction activity;
 - b. There is no potential for construction-related storm water pollutants to be discharged into site runoff;
 - c. Final stabilization has been reached;
 - d. Construction materials and wastes have been disposed of properly;
 - e. Compliance with the Post-Construction Standards in Section XIII of this General Permit has been demonstrated;
 - f. Post-construction storm water management measures have been installed and a long-term maintenance plan⁷ has been established; and
 - g. All construction-related equipment, materials and any temporary BMPs no longer needed are removed from the site.

⁷ For the purposes of this requirement a long-term maintenance plan will be designed for a minimum of five years, and will describe the procedures to ensure that the post-construction storm water management measures are adequately maintained.

2. The discharger shall certify that final stabilization conditions are satisfied in their NOT. Failure to certify shall result in continuation of permit coverage and annual billing.
3. The NOT must demonstrate through photos, RUSLE or RUSLE2, or results of testing and analysis that the site meets all of the conditions above (Section II.D.1) and the final stabilization condition (Section II.D.1.a) is attained by one of the following methods:

- a. "70% final cover method," no computational proof required

OR:

- b. "RUSLE or RUSLE2 method," computational proof required

OR:

- c. "Custom method", the discharger shall demonstrate in some other manner than a or b, above, that the site complies with the "final stabilization" requirement in Section II.D.1.a.

III. DISCHARGE PROHIBITIONS

- A.** Dischargers shall not violate any discharge prohibitions contained in applicable Basin Plans or statewide water quality control plans. Waste discharges to Areas of Special Biological Significance (ASBS) are prohibited by the California Ocean Plan, unless granted an exception issued by the State Water Board.
- B.** All discharges are prohibited except for the storm water and non-storm water discharges specifically authorized by this General Permit or another NPDES permit.
- C.** Authorized non-storm water discharges may include those from de-chlorinated potable water sources such as: fire hydrant flushing, irrigation of vegetative erosion control measures, pipe flushing and testing, water to control dust, uncontaminated ground water from dewatering, and other discharges not subject to a separate general NPDES permit adopted by a Regional Water Board. The discharge of non-storm water is authorized under the following conditions:
1. The discharge does not cause or contribute to a violation of any water quality standard;
 2. The discharge does not violate any other provision of this General Permit;
 3. The discharge is not prohibited by the applicable Basin Plan;
 4. The discharger has included and implemented specific BMPs required by this General Permit to prevent or reduce the contact of the non-storm water discharge with construction materials or equipment.
 5. The discharge does not contain toxic constituents in toxic amounts or (other) significant quantities of pollutants;
 6. The discharge is monitored and meets the applicable NALs; and
 7. The discharger reports the sampling information in the Annual Report.

If any of the above conditions are not satisfied, the discharge is not authorized by this General Permit. The discharger shall notify the Regional Water Board of any anticipated non-storm water discharges not already authorized by this General Permit or another NPDES permit, to determine whether a separate NPDES permit is necessary.

- D.** Debris resulting from construction activities are prohibited from being discharged from construction sites.

- E.** When soil contamination is found or suspected and a responsible party is not identified, or the responsible party fails to promptly take the appropriate action, the discharger shall have those soils sampled and tested to ensure proper handling and public safety measures are implemented. The discharger shall notify the appropriate local, State, and federal agency(ies) when contaminated soil is found at a construction site, and will notify the appropriate Regional Water Board.

IV. SPECIAL PROVISIONS

A. Duty to Comply

1. The discharger shall comply with all of the conditions of this General Permit. Any permit noncompliance constitutes a violation of the Clean Water Act (CWA) and the Porter-Cologne Water Quality Control Act and is grounds for enforcement action and/or removal from General Permit coverage.
2. The discharger shall comply with effluent standards or prohibitions established under Section 307(a) of the CWA for toxic pollutants within the time provided in the regulations that establish these standards or prohibitions, even if this General Permit has not yet been modified to incorporate the requirement.

B. General Permit Actions

1. This General Permit may be modified, revoked and reissued, or terminated for cause. The filing of a request by the discharger for a General Permit modification, revocation and reissuance, or termination, or a notification of planned changes or anticipated noncompliance does not annul any General Permit condition.
2. If any toxic effluent standard or prohibition (including any schedule of compliance specified in such effluent standard or prohibition) is promulgated under Section 307(a) of the CWA for a toxic pollutant which is present in the discharge and that standard or prohibition is more stringent than any limitation on the pollutant in this General Permit, this General Permit shall be modified or revoked and reissued to conform to the toxic effluent standard or prohibition and the dischargers so notified.

C. Need to Halt or Reduce Activity Not a Defense

It shall not be a defense for a discharger in an enforcement action that it would have been necessary to halt or reduce the permitted activity in order to maintain compliance with the conditions of this General Permit.

D. Duty to Mitigate

The discharger shall take all responsible steps to minimize or prevent any discharge in violation of this General Permit, which has a reasonable likelihood of adversely affecting human health or the environment.

E. Proper Operation and Maintenance

The discharger shall at all times properly operate and maintain any facilities and systems of treatment and control (and related appurtenances) which are installed or used by the discharger to achieve compliance with the conditions of this General Permit. Proper operation and maintenance also includes adequate laboratory controls and appropriate quality assurance procedures. Proper operation and maintenance may require the operation of backup or auxiliary facilities or similar systems installed by a discharger when necessary to achieve compliance with the conditions of this General Permit.

F. Property Rights

This General Permit does not convey any property rights of any sort or any exclusive privileges, nor does it authorize any injury to private property or any invasion of personal rights, nor does it authorize any infringement of Federal, State, or local laws or regulations.

G. Duty to Maintain Records and Provide Information

1. The discharger shall maintain a paper or electronic copy of all required records, including a copy of this General Permit, for three years from the date generated or date submitted, whichever is last. These records shall be available at the construction site until construction is completed.
2. The discharger shall furnish the Regional Water Board, State Water Board, or U.S. EPA, within a reasonable time, any requested information to determine compliance with this General Permit. The discharger shall also furnish, upon request, copies of records that are required to be kept by this General Permit.

H. Inspection and Entry

The discharger shall allow the Regional Water Board, State Water Board, U.S. EPA, and/or, in the case of construction sites which discharge through a municipal separate storm sewer, an authorized representative of the municipal operator of the separate storm sewer system receiving the discharge, upon the presentation of credentials and other documents as may be required by law, to:

1. Enter upon the discharger's premises at reasonable times where a regulated construction activity is being conducted or where records must be kept under the conditions of this General Permit;

2. Access and copy at reasonable times any records that must be kept under the conditions of this General Permit;
3. Inspect at reasonable times the complete construction site, including any off-site staging areas or material storage areas, and the erosion/sediment controls; and
4. Sample or monitor at reasonable times for the purpose of ensuring General Permit compliance.

I. Electronic Signature and Certification Requirements

1. All Permit Registration Documents (PRDs) and Notices of Termination (NOTs) shall be electronically signed, certified, and submitted via SMARTS to the State Water Board. Either the Legally Responsible Person (LRP), as defined in Appendix 5 – Glossary, or a person legally authorized to sign and certify PRDs and NOTs on behalf of the LRP (the LRP's Approved Signatory, as defined in Appendix 5 - Glossary) must submit all information electronically via SMARTS.
2. Changes to Authorization. If an Approved Signatory's authorization is no longer accurate, a new authorization satisfying the requirements of paragraph (a) of this section must be submitted via SMARTS prior to or together with any reports, information or applications to be signed by an Approved Signatory.
3. All Annual Reports, or other information required by the General Permit (other than PRDs and NOTs) or requested by the Regional Water Board, State Water Board, U.S. EPA, or local storm water management agency shall be certified and submitted by the LRP or the LRP's Approved Signatory.

J. Certification

Any person signing documents under Section IV.I above, shall make the following certification:

"I certify under penalty of law that this document and all attachments were prepared under my direction or supervision in accordance with a system designed to assure that qualified personnel properly gather and evaluate the information submitted. Based on my inquiry of the person or persons who manage the system or those persons directly responsible for gathering the information, to the best of my knowledge and belief, the information submitted is, true, accurate, and complete. I am aware that there are significant penalties for submitting false information, including the possibility of fine and imprisonment for knowing violations."

K. Anticipated Noncompliance

The discharger shall give advance notice to the Regional Water Board and local storm water management agency of any planned changes in the construction activity, which may result in noncompliance with General Permit requirements.

L. Bypass

Bypass⁸ is prohibited. The Regional Water Board may take enforcement action against the discharger for bypass unless:

1. Bypass was unavoidable to prevent loss of life, personal injury or severe property damage;⁹
2. There were no feasible alternatives to bypass, such as the use of auxiliary treatment facilities, retention of untreated waste, or maintenance during normal periods of equipment downtime. This condition is not satisfied if adequate back-up equipment should have been installed in the exercise of reasonable engineering judgment to prevent a bypass that could occur during normal periods of equipment downtime or preventative maintenance;
3. The discharger submitted a notice at least ten days in advance of the need for a bypass to the Regional Water Board; or
4. The discharger may allow a bypass to occur that does not cause effluent limitations to be exceeded, but only if it is for essential maintenance to assure efficient operation. In such a case, the above bypass conditions are not applicable. The discharger shall submit notice of an unanticipated bypass as required.

M. Upset

1. A discharger that wishes to establish the affirmative defense of an upset¹⁰ in an action brought for noncompliance shall demonstrate,

⁸ The intentional diversion of waste streams from any portion of a treatment facility

⁹ Severe property damage means substantial physical damage to property, damage to the treatment facilities that causes them to become inoperable, or substantial and permanent loss of natural resources that can reasonably be expected to occur in the absence of a bypass. Severe property damage does not mean economic loss caused by delays in production.

¹⁰ An exceptional incident in which there is unintentional and temporary noncompliance the technology based numeric effluent limitations because of factors beyond the reasonable control of the discharger. An upset does not include noncompliance to the extent caused by operational error, improperly designed treatment facilities, inadequate treatment facilities, lack of preventative maintenance, or careless or improper operation.

through properly signed, contemporaneous operating logs, or other relevant evidence that:

- a. An upset occurred and that the discharger can identify the cause(s) of the upset
 - b. The treatment facility was being properly operated by the time of the upset
 - c. The discharger submitted notice of the upset as required; and
 - d. The discharger complied with any remedial measures required
2. No determination made before an action of noncompliance occurs, such as during administrative review of claims that noncompliance was caused by an upset, is final administrative action subject to judicial review.
 3. In any enforcement proceeding, the discharger seeking to establish the occurrence of an upset has the burden of proof

N. Penalties for Falsification of Reports

Section 309(c)(4) of the CWA provides that any person who knowingly makes any false material statement, representation, or certification in any record or other document submitted or required to be maintained under this General Permit, including reports of compliance or noncompliance shall upon conviction, be punished by a fine of not more than \$10,000 or by imprisonment for not more than two years or by both.

O. Oil and Hazardous Substance Liability

Nothing in this General Permit shall be construed to preclude the institution of any legal action or relieve the discharger from any responsibilities, liabilities, or penalties to which the discharger is or may be subject to under Section 311 of the CWA.

P. Severability

The provisions of this General Permit are severable; and, if any provision of this General Permit or the application of any provision of this General Permit to any circumstance is held invalid, the application of such provision to other circumstances and the remainder of this General Permit shall not be affected thereby.

Q. Reopener Clause

This General Permit may be modified, revoked and reissued, or terminated for cause due to promulgation of amended regulations, receipt of U.S. EPA guidance concerning regulated activities, judicial decision, or in accordance with 40 Code of Federal Regulations (CFR) 122.62, 122.63, 122.64, and 124.5.

R. Penalties for Violations of Permit Conditions

1. Section 309 of the CWA provides significant penalties for any person who violates a permit condition implementing Sections 301, 302, 306, 307, 308, 318, or 405 of the CWA or any permit condition or limitation implementing any such section in a permit issued under Section 402. Any person who violates any permit condition of this General Permit is subject to a civil penalty not to exceed \$37,500¹¹ per calendar day of such violation, as well as any other appropriate sanction provided by Section 309 of the CWA.
2. The Porter-Cologne Water Quality Control Act also provides for civil and criminal penalties, which in some cases are greater than those under the CWA.

S. Transfers

This General Permit is not transferable.

T. Continuation of Expired Permit

This General Permit continues in force and effect until a new General Permit is issued or the SWRCB rescinds this General Permit. Only those dischargers authorized to discharge under the expiring General Permit are covered by the continued General Permit.

¹¹ May be further adjusted in accordance with the Federal Civil Penalties Inflation Adjustment Act.

V. EFFLUENT STANDARDS & RECEIVING WATER MONITORING

A. Narrative Effluent Limitations

1. Storm water discharges and authorized non-storm water discharges regulated by this General Permit shall not contain a hazardous substance equal to or in excess of reportable quantities established in 40 C.F.R. §§ 117.3 and 302.4, unless a separate NPDES Permit has been issued to regulate those discharges.
2. Dischargers shall minimize or prevent pollutants in storm water discharges and authorized non-storm water discharges through the use of controls, structures, and management practices that achieve BAT for toxic and non-conventional pollutants and BCT for conventional pollutants.

Table 1- Numeric Action Levels, Test Methods, Detection Limits, and Reporting Units

Parameter	Test Method	Discharge Type	Min. Detection Limit	Units	Numeric Action Level
pH	Field test with calibrated portable instrument	Risk Level 2	0.2	pH units	lower NAL = 6.5 upper NAL = 8.5
		Risk Level 3			lower NAL = 6.5 upper NAL = 8.5
Turbidity	EPA 0180.1 and/or field test with calibrated portable instrument	Risk Level 2	1	NTU	250 NTU
		Risk Level 3			250 NTU

B. Numeric Action Levels (NALs)

1. For Risk Level 2 and 3 dischargers, the lower storm event average NAL for pH is 6.5 pH units and the upper storm event average NAL for

pH is 8.5 pH units. The discharger shall take actions as described below if the discharge is outside of this range of pH values.

2. For Risk Level 2 and 3 dischargers, the NAL storm event daily average for turbidity is 250 NTU. The discharger shall take actions as described below if the discharge is outside of this range of turbidity values.
3. Whenever the results from a storm event daily average indicate that the discharge is below the lower NAL for pH, exceeds the upper NAL for pH, or exceeds the turbidity NAL (as listed in Table 1), the discharger shall conduct a construction site and run-on evaluation to determine whether pollutant source(s) associated with the site's construction activity may have caused or contributed to the NAL exceedance and shall immediately implement corrective actions if they are needed.
4. The site evaluation shall be documented in the SWPPP and specifically address whether the source(s) of the pollutants causing the exceedance of the NAL:
 - a. Are related to the construction activities and whether additional BMPs are required to (1) meet BAT/BCT requirements; (2) reduce or prevent pollutants in storm water discharges from causing exceedances of receiving water objectives; and (3) determine what corrective action(s) were taken or will be taken and with a description of the schedule for completion.

AND/OR:

- b. Are related to the run-on associated with the construction site location and whether additional BMPs measures are required to (1) meet BAT/BCT requirements; (2) reduce or prevent pollutants in storm water discharges from causing exceedances of receiving water objectives; and (3) what corrective action(s) were taken or will be taken with a description of the schedule for completion.

C. Receiving Water Monitoring Triggers

1. The receiving water monitoring triggers for Risk Level 3 dischargers with direct discharges to surface waters are triggered when the daily average effluent pH values during any site phase when there is a high risk of pH discharge¹² fall outside of the range of 6.0 and 9.0 pH units, or when the daily average effluent turbidity exceeds 500 NTU.

2. Risk Level 3 dischargers with with direct discharges to surface waters shall conduct receiving water monitoring whenever their effluent monitoring results exceed the receiving water monitoring triggers. If the pH trigger is exceeded, the receiving water shall be monitored for pH for the duration of coverage under this General Permit. If the turbidity trigger is exceeded, the receiving water shall be monitored for turbidity and SSC for the duration of coverage under this general permit.
3. Risk Level 3 dischargers with direct discharges to surfaces waters shall initiate receiving water monitoring when the triggers are exceeded unless the storm event causing the exceedance is determined after the fact to equal to or greater than the 5-year 24-hour storm (expressed in inches of rainfall) as determined by using these maps:

<http://www.wrcc.dri.edu/pcpnfreq/nca5y24.gif>
<http://www.wrcc.dri.edu/pcpnfreq/sca5y24.gif>

Verification of the 5-year 24-hour storm event shall be done by reporting on-site rain gauge readings as well as nearby governmental rain gauge readings.

4. If run-on is caused by a forest fire or any other natural disaster, then receiving water monitoring triggers do not apply.

¹² A period of high risk of pH discharge is defined as a project's complete utilities phase, complete vertical build phase, and any portion of any phase where significant amounts of materials are placed directly on the land at the site in a manner that could result in significant alterations of the background pH of the discharges.

VI. RECEIVING WATER LIMITATIONS

- A.** The discharger shall ensure that storm water discharges and authorized non-storm water discharges to any surface or ground water will not adversely affect human health or the environment.
- B.** The discharger shall ensure that storm water discharges and authorized non-storm water discharges will not contain pollutants in quantities that threaten to cause pollution or a public nuisance.
- C.** The discharger shall ensure that storm water discharges and authorized non-storm water discharges will not contain pollutants that cause or contribute to an exceedance of any applicable water quality objectives or water quality standards (collectively, WQS) contained in a Statewide Water Quality Control Plan, the California Toxics Rule, the National Toxics Rule, or the applicable Regional Water Board's Water Quality Control Plan (Basin Plan).
- D.** Dischargers located within the watershed of a CWA § 303(d) impaired water body, for which a TMDL has been approved by the U.S. EPA, shall comply with the approved TMDL if it identifies "construction activity" or land disturbance as a source of the pollution.

VII. TRAINING QUALIFICATIONS AND CERTIFICATION REQUIREMENTS

A. General

The discharger shall ensure that all persons responsible for implementing requirements of this General Permit shall be appropriately trained in accordance with this Section. Training should be both formal and informal, occur on an ongoing basis, and should include training offered by recognized governmental agencies or professional organizations. Those responsible for preparing and amending SWPPPs shall comply with the requirements in this Section VII.

The discharger shall provide documentation of all training for persons responsible for implementing the requirements of this General Permit in the Annual Reports.

B. SWPPP Certification Requirements

1. **Qualified SWPPP Developer:** The discharger shall ensure that SWPPPs are written, amended and certified by a Qualified SWPPP Developer (QSD). A QSD shall have one of the following registrations or certifications, and appropriate experience, as required for:
 - a. A California registered professional civil engineer;
 - b. A California registered professional geologist or engineering geologist;
 - c. A California registered landscape architect;
 - d. A professional hydrologist registered through the American Institute of Hydrology;
 - e. A Certified Professional in Erosion and Sediment Control (CPESC)TM registered through Enviro Cert International, Inc.;
 - f. A Certified Professional in Storm Water Quality (CPSWQ)TM registered through Enviro Cert International, Inc.; or
 - g. A professional in erosion and sediment control registered through the National Institute for Certification in Engineering Technologies (NICET).

Effective two years after the adoption date of this General Permit, a QSD shall have attended a State Water Board-sponsored or approved QSD training course.

2. The discharger shall list the name and telephone number of the currently designated Qualified SWPPP Developer(s) in the SWPPP.
3. **Qualified SWPPP Practitioner:** The discharger shall ensure that all BMPs required by this General Permit are implemented by a Qualified SWPPP Practitioner (QSP). A QSP is a person responsible for non-storm water and storm water visual observations, sampling and analysis. Effective two years from the date of adoption of this General Permit, a QSP shall be either a QSD or have one of the following certifications:
 - a. A certified erosion, sediment and storm water inspector registered through Enviro Cert International, Inc.; or
 - b. A certified inspector of sediment and erosion control registered through Certified Inspector of Sediment and Erosion Control, Inc.

Effective two years after the adoption date of this General Permit, a QSP shall have attended a State Water Board-sponsored or approved QSP training course.

4. The LRP shall list in the SWPPP, the name of any Approved Signatory, and provide a copy of the written agreement or other mechanism that provides this authority from the LRP in the SWPPP.
5. The discharger shall include, in the SWPPP, a list of names of all contractors, subcontractors, and individuals who will be directed by the Qualified SWPPP Practitioner. This list shall include telephone numbers and work addresses. Specific areas of responsibility of each subcontractor and emergency contact numbers shall also be included.
6. The discharger shall ensure that the SWPPP and each amendment will be signed by the Qualified SWPPP Developer. The discharger shall include a listing of the date of initial preparation and the date of each amendment in the SWPPP.

VIII. RISK DETERMINATION

The discharger shall calculate the site's sediment risk and receiving water risk during periods of soil exposure (i.e. grading and site stabilization) and use the calculated risks to determine a Risk Level(s) using the methodology in

Appendix 1. For any site that spans two or more planning watersheds,¹³ the discharger shall calculate a separate Risk Level for each planning watershed. The discharger shall notify the State Water Board of the site's Risk Level determination(s) and shall include this determination as a part of submitting the PRDs. If a discharger ends up with more than one Risk Level determination, the Regional Water Board may choose to break the project into separate levels of implementation.

IX. RISK LEVEL 1 REQUIREMENTS

Risk Level 1 Dischargers shall comply with the requirements included in Attachment C of this General Permit.

X. RISK LEVEL 2 REQUIREMENTS

Risk Level 2 Dischargers shall comply with the requirements included in Attachment D of this General Permit.

XI. RISK LEVEL 3 REQUIREMENTS

Risk Level 3 Dischargers shall comply with the requirements included in Attachment E of this General Permit.

XII. ACTIVE TREATMENT SYSTEMS (ATS)

Dischargers choosing to implement an ATS on their site shall comply with all of the requirements in Attachment F of this General Permit.

¹³ Planning watershed: defined by the Calwater Watershed documents as a watershed that ranges in size from approximately 3,000 to 10,000 acres <http://cain.ice.ucdavis.edu/calwater/calwfaq.html>, <http://gis.ca.gov/catalog/BrowseRecord.epl?id=22175> .

XIII. POST-CONSTRUCTION STANDARDS

- A.** All dischargers shall comply with the following runoff reduction requirements unless they are located within an area subject to post-construction standards of an active Phase I or II municipal separate storm sewer system (MS4) permit that has an approved Storm Water Management Plan.
1. This provision shall take effect three years from the adoption date of this permit, or later at the discretion of the Executive Officer of the Regional Board.
 2. The discharger shall demonstrate compliance with the requirements of this section by submitting with their NOI a map and worksheets in accordance with the instructions in Appendix 2. The discharger shall use non-structural controls unless the discharger demonstrates that non-structural controls are infeasible or that structural controls will produce greater reduction in water quality impacts.
 3. The discharger shall, through the use of non-structural and structural measures as described in Appendix 2, replicate the pre-project water balance (for this permit, defined as the volume of rainfall that ends up as runoff) for the smallest storms up to the 85th percentile storm event (or the smallest storm event that generates runoff, whichever is larger). Dischargers shall inform Regional Water Board staff at least 30 days prior to the use of any structural control measure used to comply with this requirement. Volume that cannot be addressed using non-structural practices shall be captured in structural practices and approved by the Regional Water Board. When seeking Regional Board approval for the use of structural practices, dischargers shall document the infeasibility of using non-structural practices on the project site, or document that there will be fewer water quality impacts through the use of structural practices.
 4. For sites whose disturbed area exceeds two acres, the discharger shall preserve the pre-construction drainage density (miles of stream length per square mile of drainage area) for all drainage areas within the area serving a first order stream¹⁴ or larger stream and ensure that post-project time of runoff concentration is equal or greater than pre-project time of concentration.

¹⁴ A first order stream is defined as a stream with no tributaries.

- B.** All dischargers shall implement BMPs to reduce pollutants in storm water discharges that are reasonably foreseeable after all construction phases have been completed at the site (Post-construction BMPs).

XIV. SWPPP REQUIREMENTS

- A.** The discharger shall ensure that the Storm Water Pollution Prevention Plans (SWPPPs) for all traditional project sites are developed and amended or revised by a QSD. The SWPPP shall be designed to address the following objectives:
1. All pollutants and their sources, including sources of sediment associated with construction, construction site erosion and all other activities associated with construction activity are controlled;
 2. Where not otherwise required to be under a Regional Water Board permit, all non-storm water discharges are identified and either eliminated, controlled, or treated;
 3. Site BMPs are effective and result in the reduction or elimination of pollutants in storm water discharges and authorized non-storm water discharges from construction activity to the BAT/BCT standard;
 4. Calculations and design details as well as BMP controls for site run-on are complete and correct, and
 5. Stabilization BMPs installed to reduce or eliminate pollutants after construction are completed.
- B.** To demonstrate compliance with requirements of this General Permit, the QSD shall include information in the SWPPP that supports the conclusions, selections, use, and maintenance of BMPs.
- C.** The discharger shall make the SWPPP available at the construction site during working hours while construction is occurring and shall be made available upon request by a State or Municipal inspector. When the original SWPPP is retained by a crewmember in a construction vehicle and is not currently at the construction site, current copies of the BMPs and map/drawing will be left with the field crew and the original SWPPP shall be made available via a request by radio/telephone.

XV. REGIONAL WATER BOARD AUTHORITIES

- A.** In the case where the Regional Water Board does not agree with the discharger's self-reported risk level (e.g., they determine themselves to be a Level 1 Risk when they are actually a Level 2 Risk site), Regional Water Boards may either direct the discharger to reevaluate the Risk Level(s) for their site or terminate coverage under this General Permit.
- B.** Regional Water Boards may terminate coverage under this General Permit for dischargers who fail to comply with its requirements or where they determine that an individual NPDES permit is appropriate.
- C.** Regional Water Boards may require dischargers to submit a Report of Waste Discharge / NPDES permit application for Regional Water Board consideration of individual requirements.
- D.** Regional Water Boards may require additional Monitoring and Reporting Program Requirements, including sampling and analysis of discharges to sediment-impaired water bodies.
- E.** Regional Water Boards may require dischargers to retain records for more than the three years required by this General Permit.

XVI. ANNUAL REPORTING REQUIREMENTS

- A.** All dischargers shall prepare and electronically submit an Annual Report no later than September 1 of each year.
- B.** The discharger shall certify each Annual Report in accordance with the Special Provisions.
- C.** The discharger shall retain an electronic or paper copy of each Annual Report for a minimum of three years after the date the annual report is filed.
- D.** The discharger shall include storm water monitoring information in the Annual Report consisting of:
 - 1. a summary and evaluation of all sampling and analysis results, including copies of laboratory reports;
 - 2. the analytical method(s), method reporting unit(s), and method detection limit(s) of each analytical parameter (analytical results that are less than the method detection limit shall be reported as "less than the method detection limit");
 - 3. a summary of all corrective actions taken during the compliance year;
 - 4. identification of any compliance activities or corrective actions that were not implemented;
 - 5. a summary of all violations of the General Permit;
 - 6. the names of individual(s) who performed the facility inspections, sampling, visual observation (inspections), and/or measurements;
 - 7. the date, place, time of facility inspections, sampling, visual observation (inspections), and/or measurements, including precipitation (rain gauge); and
 - 8. the visual observation and sample collection exception records and reports specified in Attachments C, D, and E.
- E.** The discharger shall provide training information in the Annual Report consisting of:
 - 1. documentation of all training for individuals responsible for all activities associated with compliance with this General Permit;

2. documentation of all training for individuals responsible for BMP installation, inspection, maintenance, and repair; and
3. documentation of all training for individuals responsible for overseeing, revising, and amending the SWPPP.

ATTACHMENT A
Linear Underground/ Overhead Requirements

A. DEFINITION OF LINEAR UNDERGROUND/OVERHEAD PROJECTS 1
 B. LINEAR PROJECT PERMIT REGISTRATION DOCUMENTS (PRDs) 3
 C. LINEAR PROJECT TERMINATION OF COVERAGE REQUIREMENTS .. 4
 D. DISCHARGE PROHIBITIONS 6
 E. SPECIAL PROVISIONS..... 8
 F. EFFLUENT STANDARDS & RECEIVING WATER MONITORING 13
 G. RECEIVING WATER LIMITATIONS 16
 H. TRAINING QUALIFICATIONS 17
 I. TYPES OF LINEAR PROJECTS 19
 J. LUP TYPE-SPECIFIC REQUIREMENTS 20
 K. STORM WATER POLLUTION PREVENTION PLAN (SWPPP) REQUIREMENTS 28
 L. REGIONAL WATER BOARD AUTHORITIES 29
 M. MONITORING AND REPORTING REQUIREMENTS 31

All Linear Underground/Overhead project dischargers who submit permit registration documents (PRDs) indicating their intention to be regulated under the provisions of this General Permit shall comply with the following:

A. DEFINITION OF LINEAR UNDERGROUND/OVERHEAD PROJECTS

1. Linear Underground/Overhead Projects (LUPs) include, but are not limited to, any conveyance, pipe, or pipeline for the transportation of any gaseous, liquid (including water and wastewater for domestic municipal services), liquescent, or slurry substance; any cable line or wire for the transmission of electrical energy; any cable line or wire for communications (e.g., telephone, telegraph, radio, or television messages); and associated ancillary facilities. Construction activities associated with LUPs include, but are not limited to, (a) those activities necessary for the installation of underground and overhead linear facilities (e.g., conduits, substructures, pipelines, towers, poles, cables, wires, connectors, switching, regulating and transforming equipment, and associated ancillary facilities); and include, but are not limited to, (b) underground utility mark-out, potholing, concrete and asphalt cutting and removal, trenching, excavation, boring and drilling, access road and pole/tower pad and cable/wire pull station, substation construction, substructure installation, construction of tower footings and/or foundations, pole and tower installations, pipeline installations, welding, concrete and/ or pavement repair or replacement, and stockpile/borrow locations.
2. LUP evaluation shall consist of two tasks:

- a. Confirm that the project or project section(s) qualifies as an LUP. The State Water Board website contains a project determination guidance flowchart.
http://www.waterboards.ca.gov/water_issues/programs/stormwater/constructionpermits.shtml
 - b. Identify which Type(s) (1, 2 or 3 described in Section I below) are applicable to the project or project sections based on project sediment and receiving water risk. (See Attachment A.1)
3. A Legally Responsible Person (LRP) for a Linear Underground/Overhead project is required to obtain CGP coverage under one or more permit registration document (PRD) electronic submittals to the State Water Board's Storm Water Multi-Application and Report Tracking (SMARTs) system. Attachment A.1 contains a flow chart to be used when determining if a linear project qualifies for coverage and to determine LUP Types. Since a LUP may be constructed within both developed and undeveloped locations and portions of LUPs may be constructed by different contractors, LUPs may be broken into logical permit sections. Sections may be determined based on portions of a project conducted by one contractor. Other situations may also occur, such as the time period in which the sections of a project will be constructed (e.g. project phases), for which separate permit coverage is possible. For projects that are broken into separate sections, a description of how each section relates to the overall project and the definition of the boundaries between sections shall be clearly stated.
 4. Where construction activities transverse or enter into different Regional Water Board jurisdictions, LRPs shall obtain permit coverage for each Regional Water Board area involved prior to the commencement of construction activities.
 5. Small Construction Rainfall Erosivity Waiver

EPA's Small Construction Erosivity Waiver applies to sites between one and five acres demonstrating that there are no adverse water quality impacts.

Dischargers eligible for a Rainfall Erosivity Waiver based on low erosivity potential shall complete the electronic Notice of Intent (NOI) and Sediment Risk form through the State Water Board's SMARTS system, certifying that the construction activity will take place during a period when the value of the rainfall erosivity factor is less than five. Where the LRP changes or another LRP is added during construction, the new LRP must also submit a waiver certification through the SMARTS system.

If a small linear construction site continues beyond the projected completion date given on the waiver certification, the LRP shall recalculate the rainfall erosivity factor for the new project duration and submit this information through the SMARTS system. If the new R factor is below five (5), the discharger shall update through SMARTS all applicable information on the waiver certification and retain a copy of the revised waiver onsite. The LRP shall submit the new waiver certification 30 days prior to the projected completion date listed on the original waiver form to assure exemption from permitting requirements is uninterrupted. If the new R factor is five (5) or above, the LRP shall be required to apply for coverage under this Order.

B. LINEAR PROJECT PERMIT REGISTRATION DOCUMENTS (PRDs)

Any information provided to the Regional Water Board shall comply with the Homeland Security Act and any other federal law that concerns security in the United States; any information that does not comply should not be submitted. PRDs shall consist of the following:

1. Notice of Intent (NOI)

Prior to construction activities, the LRP of a proposed linear underground/overhead project shall utilize the processes and methods provided in Attachment A.2, Permit Registration Documents (PRDs) – General Instructions for Linear Underground/Overhead Projects to comply with the Construction General Permit.

2. Site Maps

LRPs submitting PRDs shall include at least 3 maps. The first map will be a zoomed¹ 1000-1500 ft vicinity map that shows the starting point of the project. The second will be a zoomed map of 1000-1500 ft showing the ending location of the project. The third will be a larger view vicinity map, 1000 ft to 2000 ft, displaying the entire project location depending on the project size, and indicating the LUP type (1, 2 or 3) areas within the total project footprint.

3. Drawings

LRPs submitting PRDs shall include a construction drawing(s) or other appropriate drawing(s) or map(s) that shows the locations of storm drain

¹ An image with a close-up/enhanced detailed view of site features that show minute details such as streets and neighboring structures.

Or: An image with a close-up/enhanced detailed view of the site's surrounding infrastructure.

Or: An image with a close up detailed view of the project and its surroundings.

inlets and waterbodies² that may receive discharges from the construction activities and that shows the locations of BMPs to be installed for all those BMPs that can be illustrated on the revisable drawing(s) or map(s). If storm drain inlets, waterbodies, and/or BMPs cannot be adequately shown on the drawing(s) or map(s) they should be described in detail within the SWPPP.

4. Storm Water Pollution Prevention Plan (SWPPP)

LUP dischargers shall comply with the SWPPP Preparation, Implementation, and Oversight requirements in Section K of this Attachment.

5. Contact information

LUP dischargers shall include contact information for all contractors (or subcontractors) responsible for each area of an LUP project. This should include the names, telephone numbers, and addresses of contact personnel. Specific areas of responsibility of each contact, and emergency contact numbers should also be included.

6. In the case of a public emergency that requires immediate construction activities, a discharger shall submit a brief description of the emergency construction activity within five days of the onset of construction, and then shall submit all PRDs within thirty days.

C. LINEAR PROJECT TERMINATION OF COVERAGE REQUIREMENTS

The LRP may terminate coverage of an LUP when construction activities are completed by submitting an electronic notice of termination (NOT) through the State Water Board's SMARTS system. Termination requirements are different depending on the complexity of the LUP. An LUP is considered complete when: (a) there is no potential for construction-related storm water pollution; (b) all elements of the SWPPP have been completed; (c) construction materials and waste have been disposed of properly; (d) the site is in compliance with all local storm water management requirements; and (e) the LRP submits a notice of termination (NOT) and has received approval for termination from the appropriate Regional Water Board office.

1. LUP Stabilization Requirements

The LUP discharger shall ensure that all disturbed areas of the construction site are stabilized prior to termination of coverage under this General Permit. Final stabilization for the purposes of submitting an NOT

² Includes basin(s) that the MS4 storm sewer systems may drain to for Hydromodification or Hydrological Conditional of Concerns under the MS4 permits.

is satisfied when all soil disturbing activities are completed and one of the following criteria is met:

- a. In disturbed areas that were vegetated prior to construction activities of the LUP, the area disturbed must be re-established to a uniform vegetative cover equivalent to 70 percent coverage of the preconstruction vegetative conditions. Where preconstruction vegetation covers less than 100 percent of the surface, such as in arid areas, the 70 percent coverage criteria is adjusted as follows: if the preconstruction vegetation covers 50 percent of the ground surface, 70 percent of 50 percent ($.70 \times .50 = .35$) would require 35 percent total uniform surface coverage; or
- b. Where no vegetation is present prior to construction, the site is returned to its original line and grade and/or compacted to achieve stabilization; or
- c. Equivalent stabilization measures have been employed. These measures include, but are not limited to, the use of such BMPs as blankets, reinforced channel liners, soil cement, fiber matrices, geotextiles, or other erosion resistant soil coverings or treatments.

2. LUP Termination of Coverage Requirements

The LRP shall file an NOT through the State Water Board's SMARTS system. By submitting an NOT, the LRP is certifying that construction activities for an LUP are complete and that the project is in full compliance with requirements of this General Permit and that it is now compliant with soil stabilization requirements where appropriate. Upon approval by the appropriate Regional Water Board office, permit coverage will be terminated.

3. Revising Coverage for Change of Acreage

When the LRP of a portion of an LUP construction project changes, or when a phase within a multi-phase project is completed, the LRP may reduce the total acreage covered by this General Permit. In reducing the acreage covered by this General Permit, the LRP shall electronically file revisions to the PRDs that include:

- a. a revised NOI indicating the new project size;
- b. a revised site map showing the acreage of the project completed, acreage currently under construction, acreage sold, transferred or added, and acreage currently stabilized.
- c. SWPPP revisions, as appropriate; and
- d. certification that any new LRPs have been notified of applicable requirements to obtain General Permit coverage. The certification shall include the name, address, telephone number, and e-mail address (if known) of the new LRP.

If the project acreage has increased, dischargers shall mail payment of revised annual fees within 14 days of receiving the revised annual fee notification.

D. DISCHARGE PROHIBITIONS

1. LUP dischargers shall not violate any discharge prohibitions contained in applicable Basin Plans or statewide water quality control plans. Waste discharges to Areas of Special Biological Significance (ASBS) are prohibited by the California Ocean Plan, unless granted an exception issued by the State Water Board.
2. LUP dischargers are prohibited from discharging non-storm water that is not otherwise authorized by this General Permit. Non-storm water discharges authorized by this General Permit³ may include, fire hydrant flushing, irrigation of vegetative erosion control measures, pipe flushing and testing, water to control dust, street cleaning, dewatering,⁴ uncontaminated groundwater from dewatering, and other discharges not subject to a separate general NPDES permit adopted by a Regional Water Board. Such discharges are allowed by this General Permit provided they are not relied upon to clean up failed or inadequate construction or post-construction BMPs designed to keep materials on site. These authorized non-storm water discharges:

³ Dischargers must identify all authorized non-storm water discharges in the LUP's SWPPP and identify BMPs that will be implemented to either eliminate or reduce pollutants in non-storm water discharges. Regional Water Boards may direct the discharger to discontinue discharging such non-storm water discharges if determined that such discharges discharge significant pollutants or threaten water quality.

⁴Dewatering activities may be prohibited or need coverage under a separate permit issued by the Regional Water Boards. Dischargers shall check with the appropriate Regional Water Boards for any required permit or basin plan conditions prior to initial dewatering activities to land, storm drains, or waterbodies.

- a. Shall not cause or contribute to a violation of any water quality standard;
- b. Shall not violate any other provision of this General Permit;
- c. Shall not violate any applicable Basin Plan;
- d. Shall comply with BMPs as described in the SWPPP;
- e. Shall not contain toxic constituents in toxic amounts or (other) significant quantities of pollutants;
- f. Shall be monitored and meets the applicable NALs; and
- g. Shall be reported by the discharger in the Annual Report.

If any of the above conditions are not satisfied, the discharge is not authorized by this General Permit. The discharger shall notify the Regional Water Board of any anticipated non-storm water discharges not authorized by this General Permit to determine the need for a separate NPDES permit.

Additionally, some LUP dischargers may be required to obtain a separate permit if the applicable Regional Water Board has adopted a General Permit for dewatering discharges. Wherever feasible, alternatives, that do not result in the discharge of non-storm water, shall be implemented in accordance with this Attachment's Section K.2 - SWPPP Implementation Schedule.

3. LUP dischargers shall ensure that trench spoils or any other soils disturbed during construction activities that are contaminated⁵ are not discharged with storm water or non-storm water discharges into any storm drain or water body except pursuant to an NPDES permit.

When soil contamination is found or suspected and a responsible party is not identified, or the responsible party fails to promptly take the appropriate action, the LUP discharger shall have those soils sampled and tested to ensure that proper handling and public safety measures are

⁵ Contaminated soil contains pollutants in concentrations that exceed the appropriate thresholds that various regulatory agencies set for those substances. Preliminary testing of potentially contaminated soils will be based on odor, soil discoloration, or prior history of the site's chemical use and storage and other similar factors. When soil contamination is found or suspected and a responsible party is not identified, or the responsible party fails to promptly take the appropriate action, the discharger shall have those soils sampled and tested to ensure proper handling and public safety measures are implemented. The legally responsible person will notify the appropriate local, State, or federal agency(ies) when contaminated soil is found at a construction site, and will notify the Regional Water Board by submitting an NOT at the completion of the project.

- implemented. The LUP discharger shall notify the appropriate local, State, and federal agency(ies) when contaminated soil is found at a construction site, and will notify the appropriate Regional Water Board.
4. Discharging any pollutant-laden water that will cause or contribute to an exceedance of the applicable Regional Water Board's Basin Plan from a dewatering site or sediment basin into any receiving water or storm drain is prohibited.
 5. Debris⁶ resulting from construction activities are prohibited from being discharged from construction project sites.

E. SPECIAL PROVISIONS

1. Duty to Comply

- a. The LUP discharger must comply with all of the conditions of this General Permit. Any permit noncompliance constitutes a violation of the Clean Water Act (CWA) and the Porter-Cologne Water Quality Control Act and is grounds for enforcement action and/or removal from General Permit coverage.
- b. The LUP discharger shall comply with effluent standards or prohibitions established under Section 307(a) of the CWA for toxic pollutants within the time provided in the regulations that establish these standards or prohibitions, even if this General Permit has not yet been modified to incorporate the requirement.

2. General Permit Actions

- a. This General Permit may be modified, revoked and reissued, or terminated for cause. The filing of a request by the discharger for a General Permit modification, revocation and reissuance, or termination, or a notification of planned changes or anticipated noncompliance does not annul any General Permit condition.

⁶ Litter, rubble, discarded refuse, and remains of something destroyed.

- b. If any toxic effluent standard or prohibition (including any schedule of compliance specified in such effluent standard or prohibition) is promulgated under Section 307(a) of the CWA for a toxic pollutant which is present in the discharge and that standard or prohibition is more stringent than any limitation on the pollutant in this General Permit, this General Permit shall be modified or revoked and reissued to conform to the toxic effluent standard or prohibition and the dischargers so notified.

3. Need to Halt or Reduce Activity Not a Defense

It shall not be a defense for an LUP discharger in an enforcement action that it would have been necessary to halt or reduce the permitted activity in order to maintain compliance with the conditions of this General Permit.

4. Duty to Mitigate

The LUP discharger shall take all responsible steps to minimize or prevent any discharge in violation of this General Permit, which has a reasonable likelihood of adversely affecting human health or the environment.

5. Proper Operation and Maintenance

The LUP discharger shall at all times properly operate and maintain any facilities and systems of treatment and control (and related appurtenances) which are installed or used by the discharger to achieve compliance with the conditions of this General Permit and with the requirements of the Storm Water Pollution Prevention Plan (SWPPP). Proper operation and maintenance also includes adequate laboratory controls and appropriate quality assurance procedures. Proper operation and maintenance may require the operation of backup or auxiliary facilities or similar systems installed by a discharger when necessary to achieve compliance with the conditions of this General Permit.

6. Property Rights

This General Permit does not convey any property rights of any sort or any exclusive privileges, nor does it authorize any injury to private property or any invasion of personal rights, nor does it authorize any infringement of Federal, State, or local laws or regulations.

7. Duty to Maintain Records and Provide Information

- a. The LUP discharger shall maintain a paper or electronic copy of all required records, including a copy of this General Permit, for three years from the date generated or date submitted, whichever is last. These records shall be kept at the construction site or in a crew

member's vehicle until construction is completed, and shall be made available upon request.

- b. The LUP discharger shall furnish the Regional Water Board, State Water Board, or USEPA, within a reasonable time, any requested information to determine compliance with this General Permit. The LUP discharger shall also furnish, upon request, copies of records that are required to be kept by this General Permit.

8. Inspection and Entry

The LUP discharger shall allow the Regional Water Board, State Water Board, USEPA, and/or, in the case of construction sites which discharge through a municipal separate storm sewer, an authorized representative of the municipal operator of the separate storm sewer system receiving the discharge, upon the presentation of credentials and other documents as may be required by law, to:

- a. Enter upon the discharger's premises at reasonable times where a regulated construction activity is being conducted or where records must be kept under the conditions of this General Permit;
- b. Access and copy at reasonable times any records that must be kept under the conditions of this General Permit;
- c. Inspect at reasonable times the complete construction site, including any off-site staging areas or material storage areas, and the erosion/sediment controls; and
- d. Sample or monitor at reasonable times for the purpose of ensuring General Permit compliance.

9. Electronic Signature and Certification Requirements

- a. All Permit Registration Documents (PRDs) and Notices of Termination (NOTs) shall be electronically signed, certified, and submitted via SMARTS to the State Water Board. Either the Legally Responsible Person (LRP), as defined in Appendix 5 – Glossary, or a person legally authorized to sign and certify PRDs and NOTs on behalf of the LRP (the LRP's Approved Signatory, as defined in Appendix 5 - Glossary) must submit all information electronically via SMARTS.
- b. Changes to Authorization. If an Approved Signatory's authorization is no longer accurate, a new authorization satisfying the requirements of paragraph (a) of this section must be submitted via SMARTS prior to or

together with any reports, information or applications to be signed by an Approved Signatory.

- c. All SWPPP revisions, annual reports, or other information required by the General Permit (other than PRDs and NOTs) or requested by the Regional Water Board, State Water Board, USEPA, or local storm water management agency shall be certified and submitted by the LRP or the LRP's Approved Signatory.

10. Certification

Any person signing documents under Section E.9 above, shall make the following certification:

"I certify under penalty of law that this document and all attachments were prepared under my direction or supervision in accordance with a system designed to assure that qualified personnel properly gather and evaluate the information submitted. Based on my inquiry of the person or persons who manage the system or those persons directly responsible for gathering the information, to the best of my knowledge and belief, the information submitted is, true, accurate, and complete. I am aware that there are significant penalties for submitting false information, including the possibility of fine and imprisonment for knowing violations."

11. Anticipated Noncompliance

The LUP discharger shall give advance notice to the Regional Water Board and local storm water management agency of any planned changes in the construction activity, which may result in noncompliance with General Permit requirements.

12. Penalties for Falsification of Reports

Section 309(c)(4) of the CWA provides that any person who knowingly makes any false material statement, representation, or certification in any record or other document submitted or required to be maintained under this General Permit, including reports of compliance or noncompliance shall upon conviction, be punished by a fine of not more than \$10,000 or by imprisonment for not more than two years or by both.

13. Oil and Hazardous Substance Liability

Nothing in this General Permit shall be construed to preclude the institution of any legal action or relieve the discharger from any responsibilities, liabilities, or penalties to which the LUP discharger is or may be subject to under Section 311 of the CWA.

14. Severability

The provisions of this General Permit are severable; and, if any provision of this General Permit or the application of any provision of this General Permit to any circumstance is held invalid, the application of such provision to other circumstances and the remainder of this General Permit shall not be affected thereby.

15. Reopener Clause

This General Permit may be modified, revoked and reissued, or terminated for cause due to promulgation of amended regulations, receipt of USEPA guidance concerning regulated activities, judicial decision, or in accordance with 40 Code of Federal Regulations (CFR) 122.62, 122.63, 122.64, and 124.5.

16. Penalties for Violations of Permit Conditions

- a. Section 309 of the CWA provides significant penalties for any person who violates a permit condition implementing Sections 301, 302, 306, 307, 308, 318, or 405 of the CWA or any permit condition or limitation implementing any such section in a permit issued under Section 402. Any person who violates any permit condition of this General Permit is subject to a civil penalty not to exceed \$37,500⁷ per calendar day of such violation, as well as any other appropriate sanction provided by Section 309 of the CWA.
- b. The Porter-Cologne Water Quality Control Act also provides for civil and criminal penalties, which in some cases are greater than those under the CWA.

17. Transfers

This General Permit is not transferable. A new LRP of an ongoing construction activity must submit PRDs in accordance with the requirements of this General Permit to be authorized to discharge under this General Permit. An LRP who is a property owner with active General Permit coverage who sells a fraction or all the land shall inform the new property owner(s) of the requirements of this General Permit.

18. Continuation of Expired Permit

This General Permit continues in force and effect until a new General Permit is issued or the SWRCB rescinds this General Permit. Only those

⁷ May be further adjusted in accordance with the Federal Civil Penalties Inflation Adjustment Act

dischargers authorized to discharge under the expiring General Permit are covered by the continued General Permit.

F. EFFLUENT STANDARDS & RECEIVING WATER MONITORING

1. Narrative Effluent Limitations

- a. LUP dischargers shall ensure that storm water discharges and authorized non-storm water discharges regulated by this General Permit do not contain a hazardous substance equal to or in excess of reportable quantities established in 40 C.F.R. §§ 117.3 and 302.4, unless a separate NPDES Permit has been issued to regulate those discharges.
- b. LUP dischargers shall minimize or prevent pollutants in storm water discharges and authorized non-storm water discharges through the use of structural or non-structural controls, structures, and management practices that achieve BAT for toxic and non-conventional pollutants and BCT for conventional pollutants.

Table 1. Numeric Action Levels, Test Methods, Detection Limits, and Reporting Units

Parameter	Test Method	Discharge Type	Min. Detection Limit	Units	Numeric Action Level
pH	Field test with calibrated portable instrument	LUP Type 2	0.2	pH units	lower NAL = 6.5 upper NAL = 8.5
		LUP Type 3			lower NAL = 6.5 upper NAL = 8.5
Turbidity	EPA 0180.1 and/or field test with calibrated portable instrument	LUP Type 2	1	NTU	250 NTU
		LUP Type 3			250 NTU

2. Numeric Action Levels (NALs)

- a. For LUP Type 2 and 3 dischargers, the lower storm event daily average NAL for pH is 6.5 pH units and the upper storm event daily average NAL for pH is 8.5 pH units. The LUP discharger shall take actions as described below if the storm event daily average discharge is outside of this range of pH values.
- b. For LUP Type 2 and 3 dischargers, the storm event daily average NAL for turbidity is 250 NTU. The discharger shall take actions as described below if the storm event daily average discharge is outside of this range of turbidity values.
- c. Whenever daily average analytical effluent monitoring results indicate that the discharge is below the lower NAL for pH, exceeds the upper NAL for pH, or exceeds the turbidity NAL (as listed in Table 1), the LUP discharger shall conduct a construction site and run-on evaluation to determine whether pollutant source(s) associated with the site's construction activity may have caused or contributed to the NAL exceedance and shall immediately implement corrective actions if they are needed.
- d. The site evaluation will be documented in the SWPPP and specifically address whether the source(s) of the pollutants causing the exceedance of the NAL:
 - i. Are related to the construction activities and whether additional BMPs or SWPPP implementation measures are required to (1) meet BAT/BCT requirements; (2) reduce or prevent pollutants in storm water discharges from causing exceedances of receiving water objectives; and (3) determine what corrective action(s) were taken or will be taken and with a description of the schedule for completion.

AND/OR:

- ii. Are related to the run-on associated with the construction site location and whether additional BMPs or SWPPP implementation measures are required to (1) meet BAT/BCT requirements; (2) reduce or prevent pollutants in storm water discharges from causing exceedances of receiving water objectives; and (3) decide what corrective action(s) were taken or will be taken, including a description of the schedule for completion.

3. Receiving Water Monitoring Triggers

- a. The receiving water monitoring triggers for LUP Type 3 dischargers with direct discharges to surface waters are triggered when the daily average effluent pH values during any site phase when there is a high risk of pH discharge⁸ fall outside of the range of 6.0 and 9.0 pH units, or when the daily average effluent turbidity exceeds 500 NTU.
- b. LUP Type 3 dischargers with direct discharges to surface waters shall conduct receiving water monitoring whenever their effluent monitoring results exceed the receiving water monitoring triggers. If the pH trigger is exceeded, the receiving water shall be monitored for pH for the duration of coverage under this General Permit. If the turbidity trigger is exceeded, the receiving water shall be monitored for turbidity and SSC for the duration of coverage under this General Permit.
- c. LUP Type 3 dischargers with direct discharges to surface waters shall initiate receiving water monitoring when the triggers are exceeded unless the storm event causing the exceedance is determined after the fact to equal to or greater than the 5-year 24-hour storm (expressed in inches of rainfall) as determined by using these maps:

<http://www.wrcc.dri.edu/pcpnfreq/nca5y24.gif>
<http://www.wrcc.dri.edu/pcpnfreq/sca5y24.gif>

Verification of the 5-year 24-hour storm event shall be done by reporting on-site rain gauge readings as well as nearby governmental rain gauge readings.

- d. If run-on is caused by a forest fire or any other natural disaster, then receiving water monitoring triggers do not apply.

G. RECEIVING WATER LIMITATIONS

1. LUP dischargers shall ensure that storm water discharges and authorized non-storm water discharges to any surface or ground water will not adversely affect human health or the environment.
2. LUP dischargers shall ensure that storm water discharges and authorized non-storm water discharges will not contain pollutants in quantities that threaten to cause pollution or a public nuisance.
3. LUP dischargers shall ensure that storm water discharges and authorized non-storm water discharges will not contain pollutants that cause or

⁸ A period of high risk of pH discharge is defined as a project's complete utilities phase, complete vertical build phase, and any portion of any phase where significant amounts of materials are placed directly on the land at the site in a manner that could result in significant alterations of the background pH of the discharges.

contribute to an exceedance of any applicable water quality objectives or water quality standards (collectively, WQS) contained in a Statewide Water Quality Control Plan, the California Toxics Rule, the National Toxics Rule, or the applicable Regional Water Board's Water Quality Control Plan (Basin Plan).

H. TRAINING QUALIFICATIONS

1. General

All persons responsible for implementing requirements of this General Permit shall be appropriately trained. Training should be both formal and informal, occur on an ongoing basis, and should include training offered by recognized governmental agencies or professional organizations. Persons responsible for preparing, amending and certifying SWPPPs shall comply with the requirements in this Section H.

2. SWPPP Certification Requirements

- a. **Qualified SWPPP Developer:** The LUP discharger shall ensure that all SWPPPs be written, amended and certified by a Qualified SWPPP Developer (QSD). A QSD shall have one of the following registrations or certifications, and appropriate experience, as required for:
 - i A California registered professional civil engineer;
 - ii A California registered professional geologist or engineering geologist;
 - iii A California registered landscape architect;
 - iv A professional hydrologist registered through the American Institute of Hydrology;
 - v A certified professional in erosion and sediment control (CPESC)TM registered through Enviro Cert International, Inc;
 - vi A certified professional in storm water quality (CPSWQ)TM registered through Enviro Cert International, Inc.; or
 - vii A certified professional in erosion and sediment control registered through the National Institute for Certification in Engineering Technologies (NICET).

Effective two years after the adoption date of this General Permit, a QSD shall have attended a State Water Board-sponsored or approved QSD training course.

- b. The LUP discharger shall ensure that the SWPPP is written and amended, as needed, to address the specific circumstances for each construction site covered by this General Permit prior to commencement of construction activity for any stage.
- c. The LUP discharger shall list the name and telephone number of the currently designated Qualified SWPPP Developer(s) in the SWPPP.
- d. **Qualified SWPPP Practitioner:** The LUP discharger shall ensure that all elements of any SWPPP for each project will be implemented by a Qualified SWPPP Practitioner (QSP). A QSP is a person responsible for non-storm water and storm water visual observations, sampling and analysis, and for ensuring full compliance with the permit and implementation of all elements of the SWPPP. Effective two years from the date of adoption of this General Permit, a QSP shall be either a QSD or have one of the following certifications:
 - i. A certified erosion, sediment and storm water inspector registered through Certified Professional in Erosion and Sediment Control, Inc.; or
 - ii. A certified inspector of sediment and erosion control registered through Certified Inspector of Sediment and Erosion Control, Inc.

Effective two years after the adoption date of this General Permit, a QSP shall have attended a State Water Board-sponsored or approved QSP training course.

- e. The LUP discharger shall ensure that the SWPPP include a list of names of all contractors, subcontractors, and individuals who will be directed by the Qualified SWPPP Practitioner, and who is ultimately responsible for implementation of the SWPPP. This list shall include telephone numbers and work addresses. Specific areas of responsibility of each subcontractor and emergency contact numbers shall also be included.
- f. The LUP discharger shall ensure that the SWPPP and each amendment be signed by the Qualified SWPPP Developer. The LUP discharger shall include a listing of the date of initial preparation and the dates of each amendment in the SWPPP.

I. TYPES OF LINEAR PROJECTS

This attachment establishes three types (Type 1, 2 & 3) of complexity for areas within an LUP or project section based on threat to water quality. Project area Types are determined through Attachment A.1.

The Type 1 requirements below establish the baseline requirements for all LUPs subject to this General Permit. Additional requirements for Type 2 and Type 3 LUPs are labeled.

1. Type 1 LUPs:

LUP dischargers with areas of a LUP designated as Type 1 shall comply with the requirements in this Attachment. Type 1 LUPs are:

- a. Those construction areas where 70 percent or more of the construction activity occurs on a paved surface and where areas disturbed during construction will be returned to preconstruction conditions or equivalent protection established at the end of the construction activities for the day; or
- b. Where greater than 30 percent of construction activities occur within the non-paved shoulders or land immediately adjacent to paved surfaces, or where construction occurs on unpaved improved roads, including their shoulders or land immediately adjacent to them where:
 - i. Areas disturbed during construction will be returned to preconstruction conditions or equivalent protection is established at the end of the construction activities for the day to minimize the potential for erosion and sediment deposition, and
 - ii. Areas where established vegetation was disturbed during construction will be stabilized and re-vegetated by the end of project. When required, adequate temporary stabilization BMPs will be installed and maintained until vegetation is established to meet minimum cover requirements established in this General Permit for final stabilization.
- c. Where the risk determination is as follows:
 - i. Low sediment risk, low receiving water risk, or
 - ii. Low sediment risk, medium receiving water risk, or
 - iii. Medium sediment risk, low receiving water risk

2. Type 2 LUPs:

Type 2 LUPs are determined by the Combined Risk Matrix in Attachment A.1. Type 2 LUPs have the specified combination of risk:

- d. High sediment risk, low receiving water risk, or
- e. Medium sediment risk, medium receiving water risk, or
- f. Low sediment risk, high receiving water risk

Receiving water risk is either considered “Low” for those areas of the project that are not in close proximity to a sensitive receiving watershed, “Medium” for those areas of the project within a sensitive receiving watershed yet outside of the flood plain of a sensitive receiving water body, and “High” where the soil disturbance is within close proximity to a sensitive receiving water body. Project sediment risk is calculated based on the Risk Factor Worksheet in Attachment C of this General Permit.

3. Type 3 LUPs:

Type 3 LUPs are determined by the Combined Risk Matrix in Attachment A.1. Type 3 LUPs have the specified combination of risk:

- a. High sediment risk, high receiving water risk, or
- b. High sediment risk, medium receiving water risk, or
- c. Medium sediment risk, high receiving water risk

Receiving water risk is either considered “Medium” for those areas of the project within a sensitive receiving watershed yet outside of the flood plain of a sensitive receiving water body, or “High” where the soil disturbance is within close proximity to a sensitive receiving water body. Project sediment risk is calculated based on the Risk Factor Worksheet in Attachment C.

J. LUP TYPE-SPECIFIC REQUIREMENTS**1. Effluent Standards**

- a. Narrative – LUP dischargers shall comply with the narrative effluent standards below.

- i Storm water discharges and authorized non-storm water discharges regulated by this General Permit shall not contain a hazardous substance equal to or in excess of reportable quantities established in 40 C.F.R. §§ 117.3 and 302.4, unless a separate NPDES Permit has been issued to regulate those discharges.
 - ii LUP dischargers shall minimize or prevent pollutants in storm water discharges and authorized non-storm water discharges through the use of controls, structures, and management practices that achieve BAT for toxic and non-conventional pollutants and BCT for conventional pollutants.
- b. Numeric – LUP Type 1 dischargers are not subject to a numeric effluent standard
 - c. Numeric –LUP Type 2 dischargers are subject to a pH NAL of 6.5-8.5, and a turbidity NAL of 250 NTU.
 - d. Numeric – LUP Type 3 dischargers are subject to a pH NAL of 6.5-8.5, and a turbidity NAL of 250 NTU.

2. Good Site Management "Housekeeping"

- a. LUP dischargers shall implement good site management (i.e., "housekeeping") measures for construction materials that could potentially be a threat to water quality if discharged. At a minimum, the good housekeeping measures shall consist of the following:
 - i Identify the products used and/or expected to be used and the end products that are produced and/or expected to be produced. This does not include materials and equipment that are designed to be outdoors and exposed to environmental conditions (i.e. poles, equipment pads, cabinets, conductors, insulators, bricks, etc.).
 - ii Cover and berm loose stockpiled construction materials that are not actively being used (i.e. soil, spoils, aggregate, fly-ash, stucco, hydrated lime, etc.).
 - iii Store chemicals in watertight containers (with appropriate secondary containment to prevent any spillage or leakage) or in a storage shed (completely enclosed).
 - iv Minimize exposure of construction materials to precipitation (not applicable to materials designed to be outdoors and exposed to the environment).

- v Implement BMPs to control the off-site tracking of loose construction and landscape materials.
- b. LUP dischargers shall implement good housekeeping measures for waste management, which, at a minimum, shall consist of the following:
 - i Prevent disposal of any rinse or wash waters or materials on impervious or pervious site surfaces or into the storm drain system.
 - ii Ensure the containment of sanitation facilities (e.g., portable toilets) to prevent discharges of pollutants to the storm water drainage system or receiving water.
 - iii Clean or replace sanitation facilities and inspecting them regularly for leaks and spills.
 - iv Cover waste disposal containers at the end of every business day and during a rain event.
 - v Prevent discharges from waste disposal containers to the storm water drainage system or receiving water.
 - vi Contain and securely protect stockpiled waste material from wind and rain at all times unless actively being used.
 - vii Implement procedures that effectively address hazardous and non-hazardous spills.
 - viii Develop a spill response and implementation element of the SWPPP prior to commencement of construction activities. The SWPPP shall require that:
 - (1) Equipment and materials for cleanup of spills shall be available on site and that spills and leaks shall be cleaned up immediately and disposed of properly; and
 - (2) Appropriate spill response personnel are assigned and trained.
 - ix Ensure the containment of concrete washout areas and other washout areas that may contain additional pollutants so there is no discharge into the underlying soil and onto the surrounding areas.

- c. LUP dischargers shall implement good housekeeping for vehicle storage and maintenance, which, at a minimum, shall consist of the following:
 - i. Prevent oil, grease, or fuel from leaking into the ground, storm drains or surface waters.
 - ii. Implement appropriate BMPs whenever equipment or vehicles are fueled, maintained or stored.
 - iii. Clean leaks immediately and disposing of leaked materials properly.

- d. LUP dischargers shall implement good housekeeping for landscape materials, which, at a minimum, shall consist of the following:
 - i. Contain stockpiled materials such as mulches and topsoil when they are not actively being used.
 - ii. Contain fertilizers and other landscape materials when they are not actively being used.
 - iii. Discontinue the application of any erodible landscape material at least 2 days before a forecasted rain event⁹ or during periods of precipitation.
 - iv. Applying erodible landscape material at quantities and application rates according to manufacture recommendations or based on written specifications by knowledgeable and experienced field personnel.
 - v. Stacking erodible landscape material on pallets and covering or storing such materials when not being used or applied.

- e. LUP dischargers shall conduct an assessment and create a list of potential pollutant sources and identify any areas of the site where additional BMPs are necessary to reduce or prevent pollutants in storm water discharges and authorized non-storm water discharges. This potential pollutant list shall be kept with the SWPPP and shall identify all non-visible pollutants which are known, or should be known, to occur on the construction site. At a minimum, when developing BMPs, LUP dischargers shall do the following:

⁹ 50% or greater chance of producing precipitation.

- i Consider the quantity, physical characteristics (e.g., liquid, powder, solid), and locations of each potential pollutant source handled, produced, stored, recycled, or disposed of at the site.
 - ii Consider the degree to which pollutants associated with those materials may be exposed to and mobilized by contact with storm water.
 - iii Consider the direct and indirect pathways that pollutants may be exposed to storm water or authorized non-storm water discharges. This shall include an assessment of past spills or leaks, non-storm water discharges, and discharges from adjoining areas.
 - iv Ensure retention of sampling, visual observation, and inspection records.
 - v Ensure effectiveness of existing BMPs to reduce or prevent pollutants in storm water discharges and authorized non-storm water discharges.
- f. LUP dischargers shall implement good housekeeping measures on the construction site to control the air deposition of site materials and from site operations.

3. Non-Storm Water Management

- a. LUP dischargers shall implement measures to control all non-storm water discharges during construction.
- b. LUP dischargers shall wash vehicles in such a manner as to prevent non-storm water discharges to surface waters or MS4 drainage systems.
- c. LUP dischargers shall clean streets in such a manner as to prevent unauthorized non-storm water discharges from reaching surface water or MS4 drainage systems.

4. Erosion Control

- a. LUP dischargers shall implement effective wind erosion control.
- b. LUP dischargers shall provide effective soil cover for inactive¹⁰ areas and all finished slopes, and utility backfill.

¹⁰ Areas of construction activity that have been disturbed and are not scheduled to be re-disturbed for at least 14 days

- c. LUP dischargers shall limit the use of plastic materials when more sustainable, environmentally friendly alternatives exist. Where plastic materials are deemed necessary, the discharger shall consider the use of plastic materials resistant to solar degradation.

5. Sediment Controls

- a. LUP dischargers shall establish and maintain effective perimeter controls as needed, and implement effective BMPs for all construction entrances and exits to sufficiently control erosion and sediment discharges from the site.
- b. On sites where sediment basins are to be used, LUP dischargers shall, at minimum, design sediment basins according to the guidance provided in CASQA’s Construction BMP Handbook.
- c. **Additional LUP Type 2 & 3 Requirement:** LUP Type 2 & 3 dischargers shall apply linear sediment controls along the toe of the slope, face of the slope, and at the grade breaks of exposed slopes to comply with sheet flow lengths¹¹ in accordance with Table 2 below.

Table 2 – Critical Slope/Sheet Flow Length Combinations

Slope Percentage	Sheet flow length not to exceed
0-25%	20 feet
25-50%	15 feet
Over 50%	10 feet

- d. **Additional LUP Type 2 & 3 Requirement:** LUP Type 2 & 3 dischargers shall ensure that construction activity traffic to and from the project is limited to entrances and exits that employ effective controls to prevent off-site tracking of sediment.
- e. **Additional LUP Type 2 & 3 Requirement:** LUP Type 2 & 3 dischargers shall ensure that all storm drain inlets and perimeter controls, runoff control BMPs, and pollutant controls at entrances and exits (e.g. tire washoff locations) are maintained and protected from activities that reduce their effectiveness.
- f. **Additional LUP Type 2 & 3 Requirement:** LUP Type 2 & 3 dischargers shall inspect all immediate access roads. At a minimum daily and prior to any rain event, the discharger shall remove any

¹¹ Sheet flow length is the length that shallow, low velocity flow travels across a site.

sediment or other construction activity-related materials that are deposited on the roads (by vacuuming or sweeping).

- g. **Additional LUP Type 3 Requirement:** The Regional Water Board may require LUP Type 3 dischargers to implement additional site-specific sediment control requirements if the implementation of the other requirements in this section are not adequately protecting the receiving waters.

6. Run-on and Run-off Controls

- a. LUP dischargers shall effectively manage all run-on, all runoff within the site and all runoff that discharges off the site. Run-on from off site shall be directed away from all disturbed areas or shall collectively be in compliance with the effluent limitations in this Attachment.
- b. Run-on and runoff controls are not required for Type 1 LUPs unless the evaluation of quantity and quality of run-on and runoff deems them necessary or visual inspections show that the site requires such controls.

7. Inspection, Maintenance and Repair

- a. All inspection, maintenance repair and sampling activities at the discharger's LUP location shall be performed or supervised by a QSP representing the discharger. The QSP may delegate any or all of these activities to an employee trained to do the task(s) appropriately, but shall ensure adequate deployment.
- b. LUP dischargers shall conduct visual inspections and observations daily during working hours (not recorded). At least once each 24-hour period during extended storm events, **LUP Type 2 & 3 dischargers** shall conduct visual inspections to identify and record BMPs that need maintenance to operate effectively, that have failed, or that could fail to operate as intended. Inspectors shall be the QSP or be trained by the QSP.
- c. Upon identifying failures or other shortcomings, as directed by the QSP, LUP dischargers shall begin implementing repairs or design changes to BMPs within 72 hours of identification and complete the changes as soon as possible.
- d. For each pre- and post-rain event inspection required, LUP dischargers shall complete an inspection checklist, using a form provided by the State Water Board or Regional Water Board or in an alternative format that includes the information described below.

- e. The LUP discharger shall ensure that the checklist remains on-site or with the SWPPP. At a minimum, an inspection checklist should include:
 - i Inspection date and date the inspection report was written.
 - ii Weather information, including presence or absence of precipitation, estimate of beginning of qualifying storm event, duration of event, time elapsed since last storm, and approximate amount of rainfall in inches.
 - iii Site information, including stage of construction, activities completed, and approximate area of the site exposed.
 - iv A description of any BMPs evaluated and any deficiencies noted.
 - v If the construction site is safely accessible during inclement weather, list the observations of all BMPs: erosion controls, sediment controls, chemical and waste controls, and non-storm water controls. Otherwise, list the results of visual inspections at all relevant outfalls, discharge points, downstream locations and any projected maintenance activities.
 - vi Report the presence of noticeable odors or of any visible sheen on the surface of any discharges.
 - vii Any corrective actions required, including any necessary changes to the SWPPP and the associated implementation dates.
 - viii Photographs taken during the inspection, if any.
 - ix Inspector's name, title, and signature.

K. STORM WATER POLLUTION PREVENTION PLAN (SWPPP) REQUIREMENTS

1. Objectives

SWPPPs for all LUPs shall be developed and amended or revised by a QSD. The SWPPP shall be designed to address the following objectives:

- a. All pollutants and their sources, including sources of sediment, associated with construction activities associated with LUP activity are controlled;
- b. All non-storm water discharges are identified and either eliminated, controlled, or treated;
- c. BMPs are effective and result in the reduction or elimination of pollutants in storm water discharges and authorized non-storm water discharges from LUPs during construction; and
- d. Stabilization BMPs installed to reduce or eliminate pollutants after construction is completed are effective and maintained.

2. SWPPP Implementation Schedule

- a. LUPs for which PRDs have been submitted to the State Water Board shall develop a site/project location SWPPP prior to the start of land-disturbing activity in accordance with this Section and shall implement the SWPPP concurrently with commencement of soil-disturbing activities.
- b. For an ongoing LUP involving a change in the LRP, the new LRP shall review the existing SWPPP and amend it, if necessary, or develop a new SWPPP within 15 calendar days to conform to the requirements set forth in this General Permit.

3. Availability

The SWPPP shall be available at the construction site during working hours while construction is occurring and shall be made available upon request by a State or Municipal inspector. When the original SWPPP is retained by a crewmember in a construction vehicle and is not currently at the construction site, copies of the BMPs and map/drawing will be left with the field crew and the original SWPPP shall be made available via a request by radio/telephone.

L. REGIONAL WATER BOARD AUTHORITIES

1. Regional Water Boards shall administer the provisions of this General Permit. Administration of this General Permit may include, but is not limited to, requesting the submittal of SWPPPs, reviewing SWPPPs, reviewing monitoring and sampling and analysis reports, conducting compliance inspections, gathering site information by any medium including sampling, photo and video documentation, and taking enforcement actions.
2. Regional Water Boards may terminate coverage under this General Permit for dischargers who fail to comply with its requirements or where they determine that an individual NPDES permit is appropriate.
3. Regional Water Boards may issue separate permits for discharges of storm water associated with construction activity to individual dischargers, categories of dischargers, or dischargers in a geographic area. Upon issuance of such permits by a Regional Water Board, dischargers subject to those permits shall no longer be regulated by this General Permit.
4. Regional Water Boards may direct the discharger to reevaluate the LUP Type(s) for the project (or elements/areas of the project) and impose the appropriate level of requirements.
5. Regional Water Boards may terminate coverage under this General Permit for dischargers who negligently or with willful intent incorrectly determine or report their LUP Type (e.g., they determine themselves to be a LUP Type 1 when they are actually a Type 2).
6. Regional Water Boards may review PRDs and reject or accept applications for permit coverage or may require dischargers to submit a Report of Waste Discharge / NPDES permit application for Regional Water Board consideration of individual requirements.
7. Regional Water Boards may impose additional requirements on dischargers to satisfy TMDL implementation requirements or to satisfy provisions in their Basin Plans.
8. Regional Water Boards may require additional Monitoring and Reporting Program Requirements, including sampling and analysis of discharges to sediment-impaired water bodies.
9. Regional Water Boards may require dischargers to retain records for more than the three years required by this General Permit.

- 10.** Based on an LUP's threat to water quality and complexity, the Regional Water Board may determine on a case-by-case basis that an LUP, or a portion of an LUP, is not eligible for the linear project requirements contained in this Attachment, and require that the discharger comply with all standard requirements in this General Permit.

- 11.** The Regional Water Board may require additional monitoring and reporting program requirements including sampling and analysis of discharges to CWA § 303(d)-listed water bodies. Additional requirements imposed by the Regional Water Board shall be consistent with the overall monitoring effort in the receiving waters.

M. MONITORING AND REPORTING REQUIREMENTS

Table 3. LUP Summary of Monitoring Requirements

LUP Type	Visual Inspections				Sample Collection		
	Daily Site BMP	Pre-storm Event	Daily Storm BMP	Post Storm	Storm Water Discharge	Receiving Water	Non-Visible (when applicable)
		Baseline					
1	X						X
2	X	X	X	X	X		X
3	X	X	X	X	X	X	X

1. Objectives

LUP dischargers shall prepare a monitoring and reporting program (M&RP) prior to the start of construction and immediately implement the program at the start of construction for LUPs. The monitoring program must be implemented at the appropriate level to protect water quality at all times throughout the life of the project. The M&RP must be a part of the SWPPP, included as an appendix or separate SWPPP chapter.

2. M&RP Implementation Schedule

- a. LUP dischargers shall implement the requirements of this Section at the time of commencement of construction activity. LUP dischargers are responsible for implementing these requirements until construction activity is complete and the site is stabilized.
- b. LUP dischargers shall revise the M&RP when:
 - i. Site conditions or construction activities change such that a change in monitoring is required to comply with the requirements and intent of this General Permit.
 - ii. The Regional Water Board requires the discharger to revise its M&RP based on its review of the document. Revisions may include, but not be limited to, conducting additional site inspections, submitting reports, and certifications. Revisions shall be submitted via postal mail or electronic e-mail.

- iii The Regional Water Board may require additional monitoring and reporting program requirements including sampling and analysis of discharges to CWA § 303(d)-listed water bodies. Additional requirements imposed by the Regional Water Board shall be consistent with the overall monitoring effort in the receiving waters.

3. LUP Type 1 Monitoring and Reporting Requirements

a. LUP Type 1 Inspection Requirements

- i LUP Type 1 dischargers shall ensure that all inspections are conducted by trained personnel. The name(s) and contact number(s) of the assigned inspection personnel should be listed in the SWPPP.
- ii LUP Type 1 dischargers shall ensure that all visual inspections are conducted daily during working hours and in conjunction with other daily activities in areas where active construction is occurring.
- iii LUP Type 1 dischargers shall ensure that photographs of the site taken before, during, and after storm events are taken during inspections, and submitted through the State Water Board's SMARTS website once every three rain events.
- iv LUP Type 1 dischargers shall conduct daily visual inspections to verify that:
 - (1) Appropriate BMPs for storm water and non-storm water are being implemented in areas where active construction is occurring (including staging areas);
 - (2) Project excavations are closed, with properly protected spoils, and that road surfaces are cleaned of excavated material and construction materials such as chemicals by either removing or storing the material in protective storage containers at the end of every construction day;
 - (3) Land areas disturbed during construction are returned to pre-construction conditions or an equivalent protection is used at the end of each workday to eliminate or minimize erosion and the possible discharge of sediment or other pollutants during a rain event.
- v Inspections may be discontinued in non-active construction areas where soil-disturbing activities are completed and final soil stabilization is achieved (e.g., paving is completed, substructures

are installed, vegetation meets minimum cover requirements for final stabilization, or other stabilization requirements are met).

- vi Inspection programs are required for LUP Type 1 projects where temporary and permanent stabilization BMPs are installed and are to be monitored after active construction is completed. Inspection activities shall continue until adequate permanent stabilization is established and, in areas where re-vegetation is chosen, until minimum vegetative coverage is established in accordance with Section C.1 of this Attachment.

b. LUP Type 1 Monitoring Requirements for Non-Visible Pollutants

LUP Type 1 dischargers shall implement sampling and analysis requirements to monitor non-visible pollutants associated with (1) construction sites; (2) activities producing pollutants that are not visually detectable in storm water discharges; and (3) activities which could cause or contribute to an exceedance of water quality objectives in the receiving waters.

- i Sampling and analysis for non-visible pollutants is only required where the LUP Type 1 discharger believes pollutants associated with construction activities have the potential to be discharged with storm water runoff due to a spill or in the event there was a breach, malfunction, failure and/or leak of any BMP. Also, failure to implement BMPs may require sample collection.
 - (1) Visual observations made during the monitoring program described above will help the LUP Type 1 discharger determine when to collect samples.
 - (2) The LUP Type 1 discharger is not required to sample if one of the conditions described above (e.g., breach or spill) occurs and the site is cleaned of material and pollutants and/or BMPs are implemented prior to the next storm event.
- ii LUP Type 1 dischargers shall collect samples down-gradient from all discharge locations where the visual observations were made triggering the monitoring, and which can be safely accessed. For sites where sampling and analysis is required, personnel trained in water quality sampling procedures shall collect storm water samples.
- iii If sampling for non-visible pollutant parameters is required, LUP Type 1 dischargers shall ensure that samples be analyzed for parameters indicating the presence of pollutants identified in the pollutant source assessment required in Section J.2.a.i.

- iv LUP Type 1 dischargers shall collect samples during the first two hours of discharge from rain events that occur during business hours and which generate runoff.
 - v LUP Type 1 dischargers shall ensure that a sufficiently large sample of storm water that has not come into contact with the disturbed soil or the materials stored or used on-site (uncontaminated sample¹²) will be collected for comparison with the discharge sample. Samples shall be collected during the first two hours of discharge from rain events that occur during daylight hours and which generate runoff.
 - vi LUP Type 1 dischargers shall compare the uncontaminated sample to the samples of discharge using field analysis or through laboratory analysis. Analyses may include, but are not limited to, indicator parameters such as: pH, specific conductance, dissolved oxygen, conductivity, salinity, and Total Dissolved Solids (TDS).
 - vii For laboratory analyses, all sampling, sample preservation, and other analyses must be conducted according to test procedures pursuant to 40 C.F.R. Part 136. LUP Type 1 dischargers shall ensure that field samples are collected and analyzed according to manufacturer specifications of the sampling devices employed. Portable meters shall be calibrated according to manufacturer's specification.
 - viii LUP Type 1 dischargers shall ensure that all field and/or analytical data are kept in the SWPPP document.
- c. LUP Type 1 Visual Observation Exceptions
- i LUP Type 1 dischargers shall be prepared to collect samples and conduct visual observation (inspections) to meet the minimum visual observation requirements of this Attachment. The Type 1 LUP discharger is not required to physically collect samples or conduct visual observation (inspections) under the following conditions:
 - (1) During dangerous weather conditions such as flooding and electrical storms;
 - (2) Outside of scheduled site business hours.
 - (3) When access to the site is unsafe due to storm events.

¹² Sample collected at a location unaffected by construction activities.

- ii If the LUP Type 1 discharger does not collect the required samples or visual observation (inspections) due to these exceptions, an explanation why the sampling or visual observation (inspections) were not conducted shall be included in both the SWPPP and the Annual Report.
- d. Particle Size Analysis for Risk Justification

LUP Type 1 dischargers utilizing justifying an alternative project risk shall report a soil particle size analysis used to determine the RUSLE K-Factor. ASTM D-422 (Standard Test Method for Particle-Size Analysis of Soils), as revised, shall be used to determine the percentages of sand, very fine sand, silt, and clay on the site.

4. LUP Type 2 & 3 Monitoring and Reporting Requirements

- a. LUP Type 2 & 3 Inspection Requirements
- i LUP Type 2 & 3 dischargers shall ensure that all inspections are conducted by trained personnel. The name(s) and contact number(s) of the assigned inspection personnel should be listed in the SWPPP.
 - ii LUP Type 2 & 3 dischargers shall ensure that all visual inspections are conducted daily during working hours and in conjunction with other daily activities in areas where active construction is occurring.
 - iii LUP Type 2 & 3 dischargers shall ensure that photographs of the site taken before, during, and after storm events are taken during inspections, and submitted through the State Water Board's SMARTS website once every three rain events.
 - iv LUP Type 2 & 3 dischargers shall conduct daily visual inspections to verify that appropriate BMPs for storm water and non-storm water are being implemented and in place in areas where active construction is occurring (including staging areas).
 - v LUP Type 2 & 3 dischargers shall conduct inspections of the construction site prior to anticipated storm events, during extended storm events, and after actual storm events to identify areas contributing to a discharge of storm water associated with construction activity. Pre-storm inspections are to ensure that BMPs are properly installed and maintained; post-storm inspections are to assure that BMPs have functioned adequately. During

extended storm events, inspections shall be required during normal working hours for each 24-hour period.

- vi Inspections may be discontinued in non-active construction areas where soil-disturbing activities are completed and final soil stabilization is achieved (e.g., paving is completed, substructures are installed, vegetation meets minimum cover requirements for final stabilization, or other stabilization requirements are met).
- vii LUP Type 2 & 3 dischargers shall implement a monitoring program for inspecting projects that require temporary and permanent stabilization BMPs after active construction is complete. Inspections shall ensure that the BMPs are adequate and maintained. Inspection activities shall continue until adequate permanent stabilization is established and, in vegetated areas, until minimum vegetative coverage is established in accordance with Section C.1 of this Attachment.
- viii If possible, LUP Type 2 & 3 dischargers shall install a rain gauge on-site at an accessible and secure location with readings made during all storm event inspections. When readings are unavailable, data from the closest rain gauge with publically available data may be used.
- ix LUP Type 2 & 3 dischargers shall include and maintain a log of the inspections conducted in the SWPPP. The log will provide the date and time of the inspection and who conducted the inspection.

b. LUP Type 2 & 3 Storm Water Effluent Monitoring Requirements

Table 4. LUP Type 2 & 3 Effluent Monitoring Requirements

LUP Type	Frequency	Effluent Monitoring
2	Minimum of 3 samples per day characterizing discharges associated with construction activity from the project active areas of construction.	Turbidity, pH, and non-visible pollutant parameters (if applicable)
3	Minimum of 3 samples per day characterizing discharges associated with construction activity from the project active areas of construction.	turbidity, pH, and non-visible pollutant parameters (if applicable)

- i LUP Type 2 & 3 dischargers shall collect storm water grab samples from sampling locations characterizing discharges associated with activity from the LUP active areas of construction. At a minimum, 3 samples shall be collected per day of discharge.

- ii LUP Type 2 & 3 dischargers shall collect samples of stored or contained storm water that is discharged subsequent to a storm event producing precipitation of ½ inch or more at the time of discharge.
- iii LUP Type 2 & 3 dischargers shall ensure that storm water grab sample(s) obtained be representative of the flow and characteristics of the discharge.
- iv LUP Type 2 & 3 dischargers shall analyze their effluent samples for:
 - (1) pH and turbidity
 - (2) Any additional parameter for which monitoring is required by the Regional Water Board.

c. LUP Type 2 & 3 Storm Water Effluent Sampling Locations

- i LUP Type 2 & 3 dischargers shall perform sampling and analysis of storm water discharges to characterize discharges associated with construction activity from the entire disturbed project or area.
- ii LUP Type 2 & 3 dischargers may monitor and report run-on from surrounding areas if there is reason to believe run-on may contribute to exceedance of NALs.
- iii LUP Type 2 & 3 dischargers shall select analytical test methods from the list provided in Table 5 below.
- iv LUP Type 2 & 3 dischargers shall ensure that all storm water sample collection preservation and handling shall be conducted in accordance with the “Storm Water Sample Collection and Handling Instructions” below.

d. LUP Type 3 Receiving Water Monitoring Requirements

- i In the event that an LUP Type 3 discharger’s effluent exceeds the receiving water monitoring triggers of 500 NTU turbidity or pH range of 6.0-9.0, contained in this General Permit and has a direct discharge to receiving waters, the LUP discharger shall subsequently sample Receiving Waters (RWs) for turbidity, pH (if applicable) and SSC for the duration of coverage under this General Permit. In the event that an LUP Tupe 3 discharger utilizing ATS with direct discharges into receiving waters discharges effluent that exceeds the NELs in this permit, the discharger shall

subsequently sample RWs for turbidity, pH (if applicable), and SSC for the duration of coverage under this General Permit.

- ii LUP Type 3 dischargers that meet the project criteria in Appendix 3 of this General Permit and have more than 30 acres of soil disturbance in the project area or project section area designated as Type 3, shall comply with the Bioassessment requirements prior to commencement of construction activity.
 - iii LUP Type 3 dischargers shall obtain RW samples in accordance with the requirements of the Receiving Water Sampling Locations section (Section M.4.c. of this Attachment).
- e. LUP Type 3 Receiving Water Sampling Locations
- i **Upstream/up-gradient RW samples:** LUP Type 3 dischargers shall obtain any required upstream/up-gradient receiving water samples from a representative and accessible location as close as possible to and upstream from the effluent discharge point.
 - ii **Downstream/down-gradient RW samples:** LUP Type 3 dischargers shall obtain any required downstream/down-gradient receiving water samples from a representative and accessible location as close as possible to and downstream from the effluent discharge point.
 - iii If two or more discharge locations discharge to the same receiving water, LUP Type 3 dischargers may sample the receiving water at a single upstream and downstream location.

f. LUP Type 2 & 3 Monitoring Requirements for Non-Visible Pollutants

LUP Type 2 & 3 dischargers shall implement sampling and analysis requirements to monitor non-visible pollutants associated with (1) construction sites; (2) activities producing pollutants that are not visually detectable in storm water discharges; and (3) activities which could cause or contribute to an exceedance of water quality objectives in the receiving waters.

- i Sampling and analysis for non-visible pollutants is only required where LUP Type 2 & 3 dischargers believe pollutants associated with construction activities have the potential to be discharged with storm water runoff due to a spill or in the event there was a breach, malfunction, failure and/or leak of any BMP. Also, failure to implement BMPs may require sample collection.

- (1) Visual observations made during the monitoring program described above will help LUP Type 2 & 3 dischargers determine when to collect samples.
 - (2) LUP Type 2 & 3 dischargers are not required to sample if one of the conditions described above (e.g., breach or spill) occurs and the site is cleaned of material and pollutants and/or BMPs are implemented prior to the next storm event.
- ii LUP Type 2 & 3 dischargers shall collect samples down-gradient from the discharge locations where the visual observations were made triggering the monitoring and which can be safely accessed. For sites where sampling and analysis is required, personnel trained in water quality sampling procedures shall collect storm water samples.
 - iii If sampling for non-visible pollutant parameters is required, LUP Type 2 & 3 dischargers shall ensure that samples be analyzed for parameters indicating the presence of pollutants identified in the pollutant source assessment required in Section J.2.a.i.
 - iv LUP Type 2 & 3 dischargers shall collect samples during the first two hours of discharge from rain events that occur during business hours and which generate runoff.
 - v LUP Type 2 & 3 dischargers shall ensure that a sufficiently large sample of storm water that has not come into contact with the disturbed soil or the materials stored or used on-site (uncontaminated sample¹³) will be collected for comparison with the discharge sample. Samples shall be collected during the first two hours of discharge from rain events that occur during daylight hours and which generate runoff.
 - vi LUP Type 2 & 3 dischargers shall compare the uncontaminated sample to the samples of discharge using field analysis or through laboratory analysis. Analyses may include, but are not limited to, indicator parameters such as: pH, specific conductance, dissolved oxygen, conductivity, salinity, and Total Dissolved Solids (TDS).
 - vii For laboratory analyses, all sampling, sample preservation, and other analyses must be conducted according to test procedures pursuant to 40 C.F.R. Part 136. LUP Type 2 & 3 dischargers shall ensure that field samples are collected and analyzed according to manufacturer specifications of the sampling devices employed.

¹³ Sample collected at a location unaffected by construction activities

Portable meters shall be calibrated according to manufacturer's specification.

viii LUP Type 2 & 3 dischargers shall ensure that all field and/or analytical data are kept in the SWPPP document.

g. LUP Type 2 & 3 Visual Observation and Sample Collection Exceptions

i LUP Type 2 & 3 dischargers shall be prepared to collect samples and conduct visual observation (inspections) to meet the minimum visual observation requirements of this Attachment. Type 2 & 3 LUP dischargers are not required to physically collect samples or conduct visual observation (inspections) under the following conditions:

(1) During dangerous weather conditions such as flooding and electrical storms;

(2) Outside of scheduled site business hours.

(3) When access to the site is unsafe due to storm events.

ii If the LUP Type 2 or 3 discharger does not collect the required samples or visual observation (inspections) due to these exceptions, an explanation why the sampling or visual observation (inspections) were not conducted shall be included in both the SWPPP and the Annual Report.

h. LUP Type 2 & 3 Storm Water Sample Collection and Handling Instructions

LUP Type 2 & 3 dischargers shall refer to Table 5 below for test Methods, detection Limits, and reporting Units. During storm water sample collection and handling, the LUP Type 2 & 3 discharger shall:

i Identify the parameters required for testing and the number of storm water discharge points that will be sampled. Request the laboratory to provide the appropriate number of sample containers, types of containers, sample container labels, blank chain of custody forms, and sample preservation instructions.

ii Determine how to ship the samples to the laboratory. The testing laboratory should receive samples within 48 hours of the physical sampling (unless otherwise required by the laboratory). The options are to either deliver the samples to the laboratory, arrange to have the laboratory pick them up, or ship them overnight to the laboratory.

- iii Use only the sample containers provided by the laboratory to collect and store samples. Use of any other type of containers could contaminate your samples.
- iv Prevent sample contamination, by not touching, or putting anything into the sample containers before collecting storm water samples.
- v Not overfilling sample containers. Overfilling can change the analytical results.
- vi Tightly screw the cap of each sample container without stripping the threads of the cap.
- vii Complete and attach a label to each sample container. The label shall identify the date and time of sample collection, the person taking the sample, and the sample collection location or discharge point. The label should also identify any sample containers that have been preserved.
- viii Carefully pack sample containers into an ice chest or refrigerator to prevent breakage and maintain temperature during shipment. Remember to place frozen ice packs into the shipping container. Samples should be kept as close to 4° C (39° F) as possible until arriving at the laboratory. Do not freeze samples.
- ix Complete a Chain of Custody form for each set of samples. The Chain of Custody form shall include the discharger's name, address, and phone number, identification of each sample container and sample collection point, person collecting the samples, the date and time each sample container was filled, and the analysis that is required for each sample container.
- x Upon shipping/delivering the sample containers, obtain both the signatures of the persons relinquishing and receiving the sample containers.
- xi Designate and train personnel to collect, maintain, and ship samples in accordance with the above sample protocols and good laboratory practices.
- xii Refer to the Surface Water Ambient Monitoring Program's (SWAMP) 2008 Quality Assurance Program Plan (QAPrP) for more

information on sampling collection and analysis. See http://www.waterboards.ca.gov/water_issues/programs/swamp/¹⁴

Table 5. Test Methods, Detection Limits, Reporting Units and Applicable NALs

Parameter	Test Method	Discharge Type	Min. Detection Limit	Reporting Units	Numeric Action Levels	(LUP Type 3) Receiving Water Monitoring Trigger
pH	Field test with calibrated portable instrument	Type 2 & 3	0.2	pH units	Lower = 6.5 upper = 8.5	Lower = 6.0 upper = 9.0
Turbidity	EPA 0180.1 and/or field test with calibrated portable instrument	Type 2 & 3	1	NTU	250 NTU	500 NTU
SSC	ASTM Method D 3977-97 ¹⁵	Type 3 if Receiving Water Monitoring Trigger is exceeded	5	Mg/L	N/A	N/A
Bioassessment	(STE) Level I of (SAFIT), ¹⁶ fixed-count of 600 org/sample	Type 3 LUPs > 30 acres	N/A	N/A	N/A	N/A

i. LUP Type 2 & 3 Monitoring Methods

- i The LUP Type 2 or 3 discharger's project M&RP shall include a description of the following items:

- (1) Visual observation locations, visual observation procedures, and visual observation follow-up and tracking procedures.

¹⁴ Additional information regarding SWAMP's QAPrP can be found at: http://www.waterboards.ca.gov/water_issues/programs/swamp/.

¹⁵ ASTM, 1999, Standard Test Method for Determining Sediment Concentration in Water Samples: American Society of Testing and Materials, D 3977-97, Vol. 11.02, pp. 389-394

¹⁶ The current SAFIT STEs (28 November 2006) list requirements for both the Level I and Level II taxonomic effort, and are located at: http://www.swrcb.ca.gov/swamp/docs/safit/ste_list.pdf. When new editions are published by SAFIT, they will supersede all previous editions. All editions will be posted at the State Water Board's SWAMP website.

- (2) Sampling locations, and sample collection and handling procedures. This shall include detailed procedures for sample collection, storage, preservation, and shipping to the testing lab to assure that consistent quality control and quality assurance is maintained. Dischargers shall attach to the monitoring program a copy of the Chain of Custody form used when handling and shipping samples.
 - (3) Identification of the analytical methods and related method detection limits (if applicable) for each parameter required in Section M.4.f above.
- ii LUP Type 2 & 3 dischargers shall ensure that all sampling and sample preservation be in accordance with the current edition of "Standard Methods for the Examination of Water and Wastewater" (American Public Health Association). All monitoring instruments and equipment (including a discharger's own field instruments for measuring pH and turbidity) shall be calibrated and maintained in accordance with manufacturers' specifications to ensure accurate measurements. All laboratory analyses shall be conducted according to test procedures under 40 CFR Part 136, unless other test procedures have been specified in this General Permit or by the Regional Water Board. With the exception of field analysis conducted by the discharger for turbidity and pH, all analyses shall be sent to and conducted at a laboratory certified for such analyses by the State Department of Health Services (SSC exception). The LUP discharger shall conduct its own field analysis of pH and may conduct its own field analysis of turbidity if the discharger has sufficient capability (qualified and trained employees, properly calibrated and maintained field instruments, etc.) to adequately perform the field analysis.
- j. LUP Type 2 & 3 Analytical Methods

LUP Type 2 & 3 dischargers shall refer to Table 5 above for test Methods, detection Limits, and reporting Units.

- i **pH:** LUP Type 2 & 3 dischargers shall perform pH analysis on-site with a calibrated pH meter or pH test kit. The LUP discharger shall record pH monitoring results on paper and retain these records in accordance with Section M.4.o, below.
- ii **Turbidity:** LUP Type 2 & 3 dischargers shall perform turbidity analysis using a calibrated turbidity meter (turbidimeter), either on-site or at an accredited lab. Acceptable test methods include Standard Method 2130 or USEPA Method 180.1. The results shall

be recorded in the site log book in Nephelometric Turbidity Units (NTU).

- iii **Suspended sediment concentration (SSC):** LUP Type 3 dischargers exceeding the turbidity Receiving Water Monitoring Trigger, shall perform SSC analysis using ASTM Method D3977-97.
- iv **Bioassessment:** LUP Type 3 dischargers shall perform bioassessment sampling and analysis according to Appendix 3 of this General Permit.

k. Watershed Monitoring Option

If an LUP Type 2 or 3 discharger is part of a qualified regional watershed-based monitoring program the LUP Type 2 or 3 discharger may be eligible for relief from the monitoring requirements in this Attachment. The Regional Water Board may approve proposals to substitute an acceptable watershed-based monitoring program if it determines that the watershed-based monitoring program will provide information to determine each discharger's compliance with the requirements of this General Permit.

l. Particle Size Analysis for Risk Justification

LUP Type 2 & 3 dischargers justifying an alternative project risk shall report a soil particle size analysis used to determine the RUSLE K-Factor. ASTM D-422 (Standard Test Method for Particle-Size Analysis of Soils), as revised, shall be used to determine the percentages of sand, very fine sand, silt, and clay on the site.

m. NAL Exceedance Report

- i In the event that any effluent sample exceeds an applicable NAL, the Regional Water Boards may require LUP Type 2 & 3 dischargers to submit NAL Exceedance Reports.
- ii LUP Type 2 & 3 dischargers shall certify each NAL Exceedance Report in accordance with the Special Provisions for Construction Activity.
- iii LUP Type 2 & 3 dischargers shall retain an electronic or paper copy of each NAL Exceedance Report for a minimum of three years after the date the exceedance report is filed.
- iv LUP Type 2 & 3 dischargers shall include in the NAL Exceedance Report:

- (1) the analytical method(s), method reporting unit(s), and method detection limit(s) of each analytical parameter (analytical results that are less than the method detection limit shall be reported as “less than the method detection limit”); and
- (2) the date, place, time of sampling, visual observation (inspections), and/or measurements, including precipitation.
- (3) Description of the current BMPs associated with the effluent sample that exceeded the NAL and the proposed corrective actions taken.

n. Monitoring Records

LUP Type 2 & 3 dischargers shall ensure that records of all storm water monitoring information and copies of all reports (including Annual Reports) required by this General Permit be retained for a period of at least three years. LUP Type 2 & 3 dischargers may retain records off-site and make them available upon request. These records shall include:

- i The date, place, time of facility inspections, sampling, visual observation (inspections), and/or measurements, including precipitation (rain gauge);
- ii The individual(s) who performed the facility inspections, sampling, visual observation (inspections), and or measurements;
- iii The date and approximate time of analyses;
- iv The individual(s) who performed the analyses;
- v A summary of all analytical results from the last three years, the method detection limits and reporting units, the analytical techniques or methods used, and all chain of custody forms;
- vi Quality assurance/quality control records and results;
- vii Non-storm water discharge inspections and visual observation (inspections) and storm water discharge visual observation records (see Section M.4.a above);
- viii Visual observation and sample collection exception records (see Section M.4.g above); and

- ix The records of any corrective actions and follow-up activities that resulted from analytical results, visual observation (inspections), or inspections.

ATTACHMENT A.1 LUP Project Area or Project Section Area Type Determination

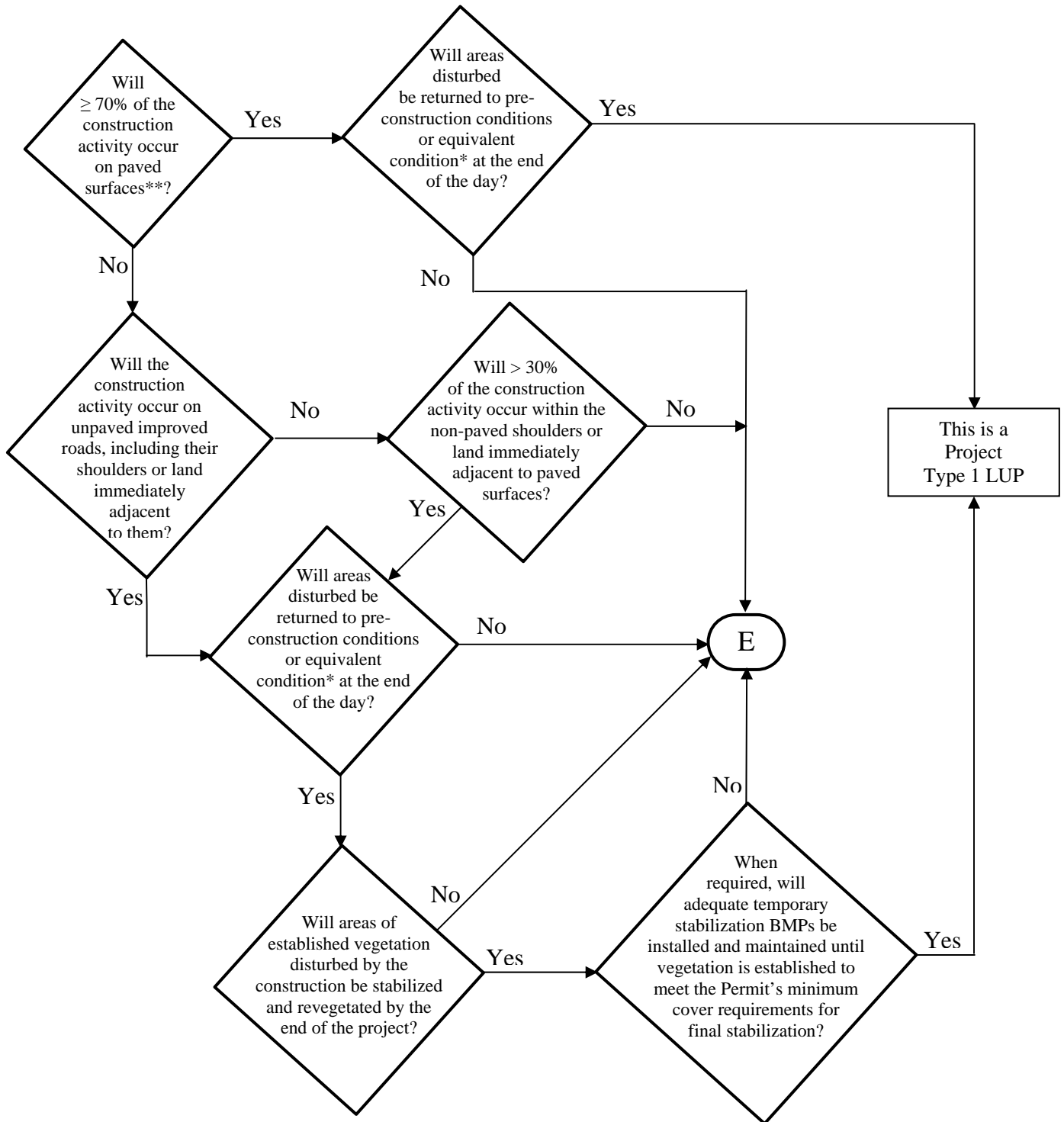

*See Definition of Terms

** Or: "Will < 30% of the soil disturbance occur on unpaved surfaces?"

ATTACHMENT A.1 LUP Project Area or Project Section Area Type Determination

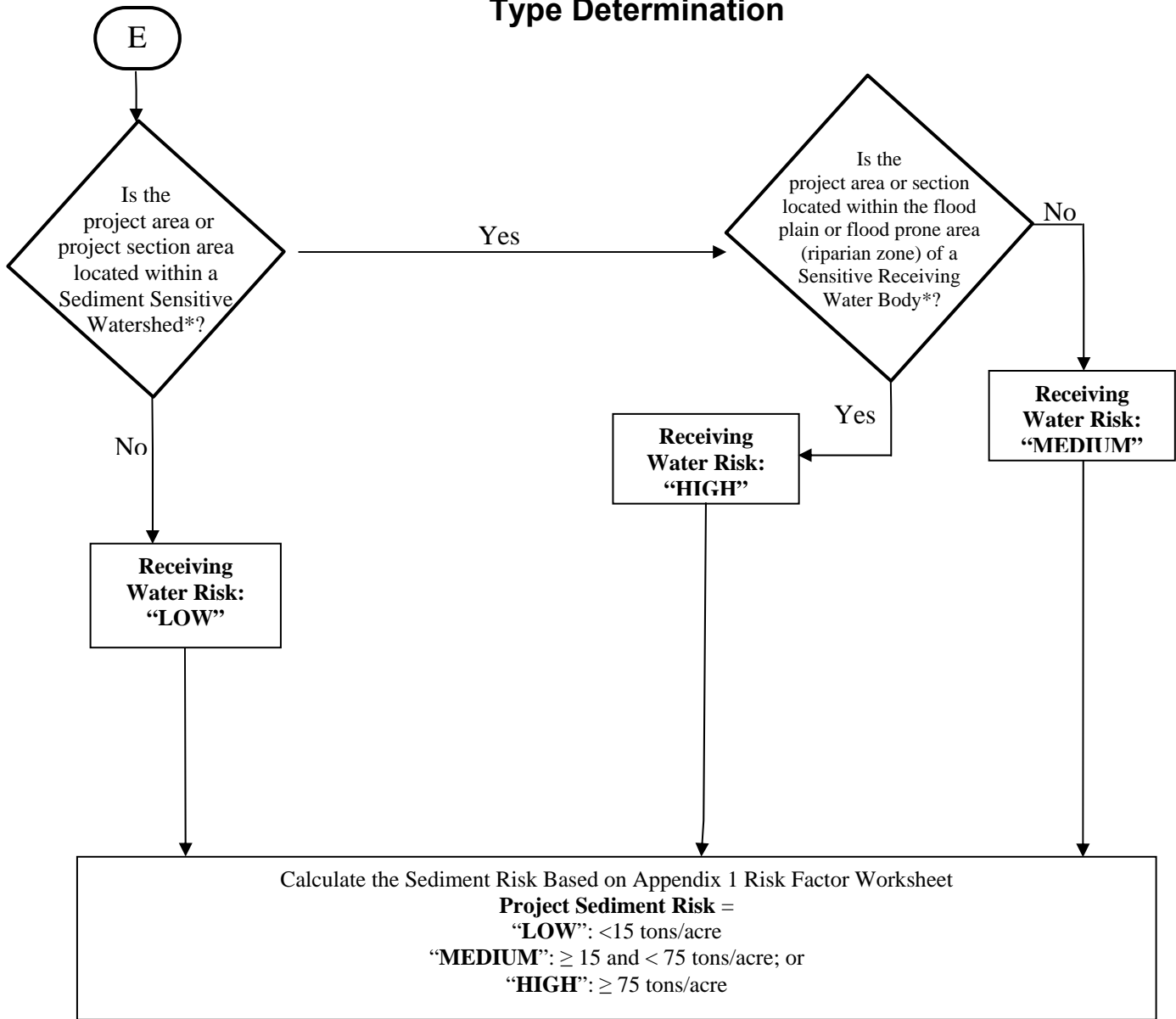

* See Definition of Terms

PROJECT SEDIMENT RISK

RECEIVING WATER RISK

	LOW	MEDIUM	HIGH
LOW	Type 1	Type 1	Type 2
MEDIUM	Type 1	Type 2	Type 3
HIGH	Type 2	Type 3	Type 3

ATTACHMENT A.1 Definition of Terms

1. **Equivalent Condition** – Means disturbed soils such as those from trench excavation are required to be hauled away, backfilled into the trench, and/or covered (e.g., metal plates, pavement, plastic covers over spoil piles) at the end of the construction day.
2. **Linear Construction Activity** – Linear construction activity consists of underground/ overhead facilities that typically include, but are not limited to, any conveyance, pipe or pipeline for the transportation of any gaseous, liquid (including water, wastewater for domestic municipal services), liquescent, or slurry substance; any cable line or wire for the transmission of electrical energy; any cable line or wire for communications (e.g., telephone, telegraph, radio or television messages); and associated ancillary facilities. Construction activities associated with LUPs include, but are not limited to those activities necessary for the installation of underground and overhead linear facilities (e.g., conduits, substructures, pipelines, towers, poles, cables, wires, connectors, switching, regulating and transforming equipment and associated ancillary facilities) and include, but are not limited to, underground utility mark-out, potholing, concrete and asphalt cutting and removal, trenching, excavation, boring and drilling, access road and pole/ tower pad and cable/ wire pull station, substation construction, substructure installation, construction of tower footings and/or foundations, pole and tower installations, pipeline installations, welding, concrete and/or pavement repair or replacement, and stockpile/ borrow locations.
3. **Sediment Sensitive Receiving Water Body** – Defined as a water body segment that is listed on EPA's approved CWA 303(d) list for sedimentation/siltation, turbidity, or is designated with beneficial uses of SPAWN, MIGRATORY, and COLD.
4. **Sediment Sensitive Watershed** – Defined as a watershed draining into a receiving water body listed on EPA's approved CWA 303(d) list for sedimentation/siltation, turbidity, or a water body designated with beneficial uses of SPAWN, MIGRATORY, and COLD.

**ATTACHMENT A.2
PERMIT REGISTRATION DOCUMENTS (PRDs)
GENERAL INSTRUCTIONS FOR LINEAR UNDERGROUND/OVERHEAD PROJECTS TO
COMPLY WITH THE CONSTRUCTION GENERAL PERMIT**

GENERAL INSTRUCTIONS

Who Must Submit

This permit is effective on July 1, 2010.

The Legally Responsible Person (LRP) for construction activities associated with linear underground/overhead project (LUP) must electronically apply for coverage under this General Permit on or after July 1, 2010. If it is determined that the LUP construction activities require an NPDES permit, the Legally Responsible Person¹ (LRP) shall submit PRDs for this General Permit in accordance with the following:

LUPs associated with Private or Municipal Development Projects

1. For LUPs associated with pre-development and pre-redevelopment construction activities:

The LRP must obtain coverage² under this General Permit for its pre-development and pre-redevelopment construction activities where the total disturbed land area of these construction activities is greater than 1 acre.

2. For LUPs associated with new development and redevelopment construction projects:

The LRP must obtain coverage under this General Permit for LUP construction activities associated with new development and redevelopment projects where the total disturbed land area of the LUP is greater than 1 acre. Coverage under this permit is not required where the same LUP construction activities are covered by another NPDES permit.

LUPs not associated with private or municipal new development or redevelopment projects:

The LRP must obtain coverage under this General Permit on or after July 1, 2010 for its LUP construction activities where the total disturbed land area is greater than 1 acre.

PRD Submittal Requirements

Prior to the start of construction activities a LRP must submit PRDs and fees to the State Water Board for each LUP.

New and Ongoing LUPs

Dischargers of new LUPs that commence construction activities after the adoption date of this General Permit shall file PRDs prior to the commencement of construction and implement the SWPPP upon the start of construction.

¹ person possessing the title of the land on which the construction activities will occur for the regulated site

² obtain coverage means filing PRDs for the project.

PERMIT REGISTRATION DOCUMENTS (PRDs) GENERAL INSTRUCTIONS (CONTINUED)

Dischargers of ongoing LUPs that are currently covered under State Water Board Order No. 2003-0007 (Small LUP General Permit) shall electronically file Permit Registration Documents no later than July 1, 2010. After July 1, 2010, all NOIs subject to State Water Board Order No. 2003-0007-DWQ will be terminated. All existing dischargers shall be exempt from the risk determination requirements in Attachment A. All existing dischargers are therefore subject to LUP Type 1 requirements regardless of their project's sediment and receiving water risks. However, a Regional Board retains the authority to require an existing discharger to comply with the risk determination requirements in Attachment A.

Where to Apply

The Permit Registration Documents (PRDs) can be found at www.waterboards.ca.gov/water_issues/programs/stormwater/

Fees

The annual fee for storm water permits are established through the State of California Code of Regulations.

When Permit Coverage Commences

To obtain coverage under the General Permit, the LRP must include the complete PRDs and the annual fee. All PRDs deemed incomplete will be rejected with an explanation as to what is required to complete submittal. Upon receipt of complete PRDs and associated fee, each discharger will be sent a waste discharger's identification (WDID) number.

Projects and Activities Not Defined As Construction Activity

1. LUP construction activity does not include routine maintenance projects to maintain original line and grade, hydraulic capacity, or original purpose of the facility. Routine maintenance projects are projects associated with operations and maintenance activities that are conducted on existing lines and facilities and within existing right-of-way, easements, franchise agreements or other legally binding agreements of the discharger. Routine maintenance projects include, but are not limited to projects that are conducted to:
 - Maintain the original purpose of the facility, or hydraulic capacity.
 - Update existing lines³ and facilities to comply with applicable codes, standards and regulations regardless if such projects result in increased capacity.
 - Repairing leaks.

Routine maintenance does not include construction of new⁴ lines or facilities resulting from compliance with applicable codes, standards and regulations.

³ Update existing lines includes replacing existing lines with new materials or pipes.

⁴ New lines are those that are not associated with existing facilities and are not part of a project to update or replace existing lines.

**PERMIT REGISTRATION DOCUMENTS (PRDs)
GENERAL INSTRUCTIONS (CONTINUED)**

Routine maintenance projects do not include those areas of maintenance projects that are outside of an existing right-of-way, franchise, easements, or agreements. When a project must acquire new areas, those areas may be subject to this General Permit based on the area of disturbed land outside the original right-of-way, easement, or agreement.

2. LUP construction activity does not include field activities associated with the planning and design of a project (e.g., activities associated with route selection).
3. Tie-ins conducted immediately adjacent to “energized” or “pressurized” facilities by the discharger are not considered small construction activities where all other LUP construction activities associated with the tie-in are covered by a NOI and SWPPP of a third party or municipal agency.

Calculating Land Disturbance Areas of LUPs

The total land area disturbed for LUPs is the sum of the:

- Surface areas of trenches, laterals and ancillary facilities, plus
- Area of the base of stockpiles on unpaved surfaces, plus
- Surface area of the borrow area, plus
- Areas of paved surfaces constructed for the project, plus
- Areas of new roads constructed or areas of major reconstruction to existing roads (e.g. improvements to two-track surfaces or road widening) for the sole purpose of accessing construction activities or as part of the final project, plus
- Equipment and material storage, staging, and preparation areas (laydown areas) not on paved surfaces, plus
- Soil areas outside the surface area of trenches, laterals and ancillary facilities that will be graded, and/or disturbed by the use of construction equipment, vehicles and machinery during construction activities.

Stockpiling Areas

Stockpiling areas, borrow areas and the removal of soils from a construction site may or may not be included when calculating the area of disturbed soil for a site depending on the following conditions:

- For stockpiling of soils onsite or immediately adjacent to a LUP site and the stockpile is not on a paved surface, the area of the base of the stockpile is to be included in the disturbed area calculation.
- The surface area of borrow areas that are onsite or immediately adjacent to a project site are to be included in the disturbed area calculation.
- For soil that is hauled offsite to a location owned or operated by the discharger that is not a paved surface, the area of the base of the stockpile is to be included in the disturbed area calculation except when the offsite location is already subject to a separate storm water permit.

**PERMIT REGISTRATION DOCUMENTS (PRDs)
GENERAL INSTRUCTIONS (CONTINUED)**

- For soil that is brought to the project from an off-site location owned or operated by the discharger the surface area of the borrow pit is to be included in the disturbed area calculation except when the offsite location is already subject to a separate storm water permit.
- Trench spoils on a paved surface that are either returned to the trench or excavation or hauled away from the project daily for disposal or reuse will not be included in the disturbed area calculation.

If you have any questions concerning submittal of PRDs, please call the State Water Board at (866) 563-3107.

This page intentionally left blank.

**ATTACHMENT B
PERMIT REGISTRATION DOCUMENTS (PRDs) TO COMPLY WITH THE TERMS
OF THE GENERAL PERMIT TO DISCHARGE STORM WATER
ASSOCIATED WITH CONSTRUCTION ACTIVITY**

GENERAL INSTRUCTIONS

- A.** All Linear Construction Projects shall comply with the PRD requirements in Attachment A.2 of this Order.

B. Who Must Submit

Discharges of storm water associated with construction that results in the disturbance of one acre or more of land must apply for coverage under the General Construction Storm Water Permit (General Permit). Any construction activity that is a part of a larger common plan of development or sale must also be permitted, regardless of size. (For example, if 0.5 acre of a 20-acre subdivision is disturbed by the construction activities of discharger A and the remaining 19.5 acres is to be developed by discharger B, discharger A must obtain a General Storm Water Permit for the 0.5 acre project).

Other discharges from construction activities that are covered under this General Permit can be found in the General Permit Section II.B.

It is the LRP's responsibility to obtain coverage under this General Permit by electronically submitting complete PRDs (Permit Registration Documents).

In all cases, the proper procedures for submitting the PRDs must be completed before construction can commence.

C. Construction Activity Not Covered By This General Permit

Discharges from construction that are not covered under this General Permit can be found in the General Permit Sections II.A & B..

D. Annual Fees and Fee Calculation

Annual fees are calculated based upon the total area of land to be disturbed not the total size of the acreage owned. However, the calculation includes all acres to be disturbed during the duration of the project. For example, if 10 acres are scheduled to be disturbed the first year and 10 in each subsequent year for 5 years, the annual fees would be based upon 50 acres of disturbance. The State Water Board will evaluate adding acreage to an existing Permit Waste Discharge Identification (WDID) number on a case-by-case basis. In general, any acreage to be considered must be contiguous to the permitted land area and the existing

SWPPP must be appropriate for the construction activity and topography of the acreage under consideration. As acreage is built out and stabilized or sold, the Change of Information (COI) form enables the applicant to remove those acres from inclusion in the annual fee calculation. Checks should be made payable to: State Water Board.

The Annual fees are established through regulations adopted by the State Water Board. The total annual fee is the current base fee plus applicable surcharges for all construction sites submitting an NOI, based on the total acreage to be disturbed during the life of the project. Annual fees are subject to change by regulation.

Dischargers that apply for and satisfy the Small Construction Erosivity Waiver requirements shall pay a fee of \$200.00 plus an applicable surcharge, see the General Permit Section II.B.7.

E. When to Apply

LRP's proposing to conduct construction activities subject to this General Permit must submit their PRDs prior to the commencement of construction activity.

F. Requirements for Completing Permit Registration Documents (PRDs)

All dischargers required to comply with this General Permit shall electronically submit the required PRDs for their type of construction as defined below.

G. Standard PRD Requirements (All Dischargers)

1. Notice of Intent
2. Risk Assessment (Standard or Site-Specific)
3. Site Map
4. SWPPP
5. Annual Fee
6. Certification

H. Additional PRD Requirements Related to Construction Type

1. Discharger in unincorporated areas of the State (not covered under an adopted Phase I or II SUSMP requirements) and that are not a linear project shall also submit a completed:
 - a. Post-Construction Water Balance Calculator (Appendix 2).
2. Dischargers who are proposing to implement ATS shall submit:
 - a. Complete ATS Plan in accordance with Attachment F at least 14 days prior to the planned operation of the ATS and a paper copy shall be available onsite during ATS operation.

- b. Certification proof that design done by a professional in accordance with Attachment F.
- 3. Dischargers who are proposing an alternate Risk Justification:
 - a. Particle Size Analysis.

I. Exceptions to Standard PRD Requirements

Construction sites with an R value less than 5 as determined in the Risk Assessment are not required to submit a SWPPP.

J. Description of PRDs

1. Notice of Intent (NOI)
2. Site Map(s) Includes:
 - a. The project's surrounding area (vicinity)
 - b. Site layout
 - c. Construction site boundaries
 - d. Drainage areas
 - e. Discharge locations
 - f. Sampling locations
 - g. Areas of soil disturbance (temporary or permanent)
 - h. Active areas of soil disturbance (cut or fill)
 - i. Locations of all runoff BMPs
 - j. Locations of all erosion control BMPs
 - k. Locations of all sediment control BMPs
 - l. ATS location (if applicable)
 - m. Locations of sensitive habitats, watercourses, or other features which are not to be disturbed
 - n. Locations of all post-construction BMPs
 - o. Locations of storage areas for waste, vehicles, service, loading/unloading of materials, access (entrance/exits) points to construction site, fueling, and water storage, water transfer for dust control and compaction practices
3. **SWPPPs**
A site-specific SWPPP shall be developed by each discharger and shall be submitted with the PRDs.
4. **Risk Assessment**
All dischargers shall use the Risk Assessment procedure as describe in the General Permit Appendix 1.
 - a. The Standard Risk Assessment includes utilization of the following:
 - i. Receiving water Risk Assessment interactive map

- ii. EPA Rainfall Erosivity Factor Calculator Website
 - iii. Sediment Risk interactive map
 - iv. Sediment sensitive water bodies list
- b. The Site-Specific Risk Assessment includes the completion of the hand calculated R value Risk Calculator
5. **Post-Construction Water Balance Calculator**
All dischargers subject to this requirement shall complete the Water Balance Calculator (in Appendix 2) in accordance with the instructions.
6. **ATS Design Document and Certification**
All dischargers using ATS must submit electronically their system design (as well as any supporting documentation) and proof that the system was designed by a qualified ATS design professional (See Attachment F).

To obtain coverage under the General Permit PRDs must be included and completed. If any of the required items are missing, the PRD submittal is considered incomplete and will be rejected. Upon receipt of a complete PRD submittal, the State Water Board will process the application package in the order received and assign a (WDID) number.

Questions?

If you have any questions on completing the PRDs please email stormwater@waterboards.ca.gov or call (866) 563-3107.

ATTACHMENT C RISK LEVEL 1 REQUIREMENTS

A. Effluent Standards

[These requirements are the same as those in the General Permit order.]

1. Narrative – Risk Level 1 dischargers shall comply with the narrative effluent standards listed below:
 - a. Storm water discharges and authorized non-storm water discharges regulated by this General Permit shall not contain a hazardous substance equal to or in excess of reportable quantities established in 40 C.F.R. §§ 117.3 and 302.4, unless a separate NPDES Permit has been issued to regulate those discharges.
 - b. Dischargers shall minimize or prevent pollutants in storm water discharges and authorized non-storm water discharges through the use of controls, structures, and management practices that achieve BAT for toxic and non-conventional pollutants and BCT for conventional pollutants.
2. Numeric – Risk Level 1 dischargers are not subject to a numeric effluent standard.

B. Good Site Management "Housekeeping"

1. Risk Level 1 dischargers shall implement good site management (i.e., "housekeeping") measures for construction materials that could potentially be a threat to water quality if discharged. At a minimum, Risk Level 1 dischargers shall implement the following good housekeeping measures:
 - a. Conduct an inventory of the products used and/or expected to be used and the end products that are produced and/or expected to be produced. This does not include materials and equipment that are designed to be outdoors and exposed to environmental conditions (i.e. poles, equipment pads, cabinets, conductors, insulators, bricks, etc.).
 - b. Cover and berm loose stockpiled construction materials that are not actively being used (i.e. soil, spoils, aggregate, fly-ash, stucco, hydrated lime, etc.).

- c. Store chemicals in watertight containers (with appropriate secondary containment to prevent any spillage or leakage) or in a storage shed (completely enclosed).
 - d. Minimize exposure of construction materials to precipitation. This does not include materials and equipment that are designed to be outdoors and exposed to environmental conditions (i.e. poles, equipment pads, cabinets, conductors, insulators, bricks, etc.).
 - e. Implement BMPs to prevent the off-site tracking of loose construction and landscape materials.
2. Risk Level 1 dischargers shall implement good housekeeping measures for waste management, which, at a minimum, shall consist of the following:
- a. Prevent disposal of any rinse or wash waters or materials on impervious or pervious site surfaces or into the storm drain system.
 - b. Ensure the containment of sanitation facilities (e.g., portable toilets) to prevent discharges of pollutants to the storm water drainage system or receiving water.
 - c. Clean or replace sanitation facilities and inspecting them regularly for leaks and spills.
 - d. Cover waste disposal containers at the end of every business day and during a rain event.
 - e. Prevent discharges from waste disposal containers to the storm water drainage system or receiving water.
 - f. Contain and securely protect stockpiled waste material from wind and rain at all times unless actively being used.
 - g. Implement procedures that effectively address hazardous and non-hazardous spills.
 - h. Develop a spill response and implementation element of the SWPPP prior to commencement of construction activities. The SWPPP shall require that:
 - i. Equipment and materials for cleanup of spills shall be available on site and that spills and leaks shall be cleaned up immediately and disposed of properly; and

- ii. Appropriate spill response personnel are assigned and trained.
 - i. Ensure the containment of concrete washout areas and other washout areas that may contain additional pollutants so there is no discharge into the underlying soil and onto the surrounding areas.
3. Risk Level 1 dischargers shall implement good housekeeping for vehicle storage and maintenance, which, at a minimum, shall consist of the following:
 - a. Prevent oil, grease, or fuel to leak in to the ground, storm drains or surface waters.
 - b. Place all equipment or vehicles, which are to be fueled, maintained and stored in a designated area fitted with appropriate BMPs.
 - c. Clean leaks immediately and disposing of leaked materials properly.
4. Risk Level 1 dischargers shall implement good housekeeping for landscape materials, which, at a minimum, shall consist of the following:
 - a. Contain stockpiled materials such as mulches and topsoil when they are not actively being used.
 - b. Contain fertilizers and other landscape materials when they are not actively being used.
 - c. Discontinue the application of any erodible landscape material within 2 days before a forecasted rain event or during periods of precipitation.
 - d. Apply erodible landscape material at quantities and application rates according to manufacture recommendations or based on written specifications by knowledgeable and experienced field personnel.
 - e. Stack erodible landscape material on pallets and covering or storing such materials when not being used or applied.
5. Risk Level 1 dischargers shall conduct an assessment and create a list of potential pollutant sources and identify any areas of the site where additional BMPs are necessary to reduce or prevent pollutants in storm water discharges and authorized non-storm water discharges. This potential pollutant list shall be kept with the SWPPP and shall identify

all non-visible pollutants which are known, or should be known, to occur on the construction site. At a minimum, when developing BMPs, Risk Level 1 dischargers shall do the following:

- a. Consider the quantity, physical characteristics (e.g., liquid, powder, solid), and locations of each potential pollutant source handled, produced, stored, recycled, or disposed of at the site.
 - b. Consider the degree to which pollutants associated with those materials may be exposed to and mobilized by contact with storm water.
 - c. Consider the direct and indirect pathways that pollutants may be exposed to storm water or authorized non-storm water discharges. This shall include an assessment of past spills or leaks, non-storm water discharges, and discharges from adjoining areas.
 - d. Ensure retention of sampling, visual observation, and inspection records.
 - e. Ensure effectiveness of existing BMPs to reduce or prevent pollutants in storm water discharges and authorized non-storm water discharges.
6. Risk Level 1 dischargers shall implement good housekeeping measures on the construction site to control the air deposition of site materials and from site operations. Such particulates can include, but are not limited to, sediment, nutrients, trash, metals, bacteria, oil and grease and organics.

C. Non-Storm Water Management

1. Risk Level 1 dischargers shall implement measures to control all non-storm water discharges during construction.
2. Risk Level 1 dischargers shall wash vehicles in such a manner as to prevent non-storm water discharges to surface waters or MS4 drainage systems.
3. Risk Level 1 dischargers shall clean streets in such a manner as to prevent unauthorized non-storm water discharges from reaching surface water or MS4 drainage systems.

D. Erosion Control

1. Risk Level 1 dischargers shall implement effective wind erosion control.
2. Risk Level 1 dischargers shall provide effective soil cover for inactive¹ areas and all finished slopes, open space, utility backfill, and completed lots.
3. Risk Level 1 dischargers shall limit the use of plastic materials when more sustainable, environmentally friendly alternatives exist. Where plastic materials are deemed necessary, the discharger shall consider the use of plastic materials resistant to solar degradation.

E. Sediment Controls

1. Risk Level 1 dischargers shall establish and maintain effective perimeter controls and stabilize all construction entrances and exits to sufficiently control erosion and sediment discharges from the site.
2. On sites where sediment basins are to be used, Risk Level 1 dischargers shall, at minimum, design sediment basins according to the method provided in CASQA's Construction BMP Guidance Handbook.

F. Run-on and Runoff Controls

Risk Level 1 dischargers shall effectively manage all run-on, all runoff within the site and all runoff that discharges off the site. Run-on from off site shall be directed away from all disturbed areas or shall collectively be in compliance with the effluent limitations in this General Permit.

G. Inspection, Maintenance and Repair

1. Risk Level 1 dischargers shall ensure that all inspection, maintenance repair and sampling activities at the project location shall be performed or supervised by a Qualified SWPPP Practitioner (QSP) representing the discharger. The QSP may delegate any or all of these activities to an employee trained to do the task(s) appropriately, but shall ensure adequate deployment.
2. Risk Level 1 dischargers shall perform weekly inspections and observations, and at least once each 24-hour period during extended

¹ Inactive areas of construction are areas of construction activity that have been disturbed and are not scheduled to be re-disturbed for at least 14 days.

storm events, to identify and record BMPs that need maintenance to operate effectively, that have failed, or that could fail to operate as intended. Inspectors shall be the QSP or be trained by the QSP.

3. Upon identifying failures or other shortcomings, as directed by the QSP, Risk Level 1 dischargers shall begin implementing repairs or design changes to BMPs within 72 hours of identification and complete the changes as soon as possible.
4. For each inspection required, Risk Level 1 dischargers shall complete an inspection checklist, using a form provided by the State Water Board or Regional Water Board or in an alternative format.
5. Risk Level 1 dischargers shall ensure that checklists shall remain onsite with the SWPPP and at a minimum, shall include:
 - a. Inspection date and date the inspection report was written.
 - b. Weather information, including presence or absence of precipitation, estimate of beginning of qualifying storm event, duration of event, time elapsed since last storm, and approximate amount of rainfall in inches.
 - c. Site information, including stage of construction, activities completed, and approximate area of the site exposed.
 - d. A description of any BMPs evaluated and any deficiencies noted.
 - e. If the construction site is safely accessible during inclement weather, list the observations of all BMPs: erosion controls, sediment controls, chemical and waste controls, and non-storm water controls. Otherwise, list the results of visual inspections at all relevant outfalls, discharge points, downstream locations and any projected maintenance activities.
 - f. Report the presence of noticeable odors or of any visible sheen on the surface of any discharges.
 - g. Any corrective actions required, including any necessary changes to the SWPPP and the associated implementation dates.
 - h. Photographs taken during the inspection, if any.
 - i. Inspector's name, title, and signature.

H. Rain Event Action Plan

Not required for Risk Level 1 dischargers.

I. Risk Level 1 Monitoring and Reporting Requirements

Table 1- Summary of Monitoring Requirements

Risk Level	Visual Inspections					Sample Collection	
	Quarterly Non-storm Water Discharge	Pre-storm Event		Daily Storm BMP	Post Storm	Storm Water Discharge	Receiving Water
		Baseline	REAP				
1	X	X		X	X		

1. Construction Site Monitoring Program Requirements

- a. Pursuant to Water Code Sections 13383 and 13267, all dischargers subject to this General Permit shall develop and implement a written site-specific Construction Site Monitoring Program (CSMP) in accordance with the requirements of this Section. The CSMP shall include all monitoring procedures and instructions, location maps, forms, and checklists as required in this section. The CSMP shall be developed prior to the commencement of construction activities, and revised as necessary to reflect project revisions. The CSMP shall be a part of the Storm Water Pollution Prevention Plan (SWPPP), included as an appendix or separate SWPPP chapter.
- b. Existing dischargers registered under the State Water Board Order No. 99-08-DWQ shall make and implement necessary revisions to their Monitoring Programs to reflect the changes in this General Permit in a timely manner, but no later than July 1, 2010. Existing dischargers shall continue to implement their existing Monitoring Programs in compliance with State Water Board Order No. 99-08-DWQ until the necessary revisions are completed according to the schedule above.
- c. When a change of ownership occurs for all or any portion of the construction site prior to completion or final stabilization, the new discharger shall comply with these requirements as of the date the ownership change occurs.

2. Objectives

The CSMP shall be developed and implemented to address the following objectives:

- a. To demonstrate that the site is in compliance with the Discharge Prohibitions;

- b. To determine whether non-visible pollutants are present at the construction site and are causing or contributing to exceedances of water quality objectives;
 - c. To determine whether immediate corrective actions, additional Best Management Practice (BMP) implementation, or SWPPP revisions are necessary to reduce pollutants in storm water discharges and authorized non-storm water discharges; and
 - d. To determine whether BMPs included in the SWPPP are effective in preventing or reducing pollutants in storm water discharges and authorized non-storm water discharges.
- 3. Risk Level 1 - Visual Monitoring (Inspection) Requirements for Qualifying Rain Events**
- a. Risk Level 1 dischargers shall visually observe (inspect) storm water discharges at all discharge locations within two business days (48 hours) after each qualifying rain event.
 - b. Risk Level 1 dischargers shall visually observe (inspect) the discharge of stored or contained storm water that is derived from and discharged subsequent to a qualifying rain event producing precipitation of ½ inch or more at the time of discharge. Stored or contained storm water that will likely discharge after operating hours due to anticipated precipitation shall be observed prior to the discharge during operating hours.
 - c. Risk Level 1 dischargers shall conduct visual observations (inspections) during business hours only.
 - d. Risk Level 1 dischargers shall record the time, date and rain gauge reading of all qualifying rain events.
 - e. Within 2 business days (48 hours) prior to each qualifying rain event, Risk Level 1 dischargers shall visually observe (inspect):
 - i. All storm water drainage areas to identify any spills, leaks, or uncontrolled pollutant sources. If needed, the discharger shall implement appropriate corrective actions.
 - ii. All BMPs to identify whether they have been properly implemented in accordance with the SWPPP. If needed, the discharger shall implement appropriate corrective actions.

- iii. Any storm water storage and containment areas to detect leaks and ensure maintenance of adequate freeboard.
- f. For the visual observations (inspections) described in e.i and e.iii above, Risk Level 1 dischargers shall observe the presence or absence of floating and suspended materials, a sheen on the surface, discolorations, turbidity, odors, and source(s) of any observed pollutants.
- g. Within two business days (48 hours) after each qualifying rain event, Risk Level 1 dischargers shall conduct post rain event visual observations (inspections) to (1) identify whether BMPs were adequately designed, implemented, and effective, and (2) identify additional BMPs and revise the SWPPP accordingly.
- h. Risk Level 1 dischargers shall maintain on-site records of all visual observations (inspections), personnel performing the observations, observation dates, weather conditions, locations observed, and corrective actions taken in response to the observations.

4. Risk Level 1 – Visual Observation Exemptions

- a. Risk Level 1 dischargers shall be prepared to conduct visual observation (inspections) until the minimum requirements of Section I.3 above are completed. Risk Level 1 dischargers are not required to conduct visual observation (inspections) under the following conditions:
 - i. During dangerous weather conditions such as flooding and electrical storms.
 - ii. Outside of scheduled site business hours.
- b. If no required visual observations (inspections) are collected due to these exceptions, Risk Level 1 dischargers shall include an explanation in their SWPPP and in the Annual Report documenting why the visual observations (inspections) were not conducted.

5. Risk Level 1 – Monitoring Methods

Risk Level 1 dischargers shall include a description of the visual observation locations, visual observation procedures, and visual observation follow-up and tracking procedures in the CSMP.

6. Risk Level 1 – Non-Storm Water Discharge Monitoring Requirements

- a. Visual Monitoring Requirements:
 - i. Risk Level 1 dischargers shall visually observe (inspect) each drainage area for the presence of (or indications of prior) unauthorized and authorized non-storm water discharges and their sources.
 - ii. Risk Level 1 dischargers shall conduct one visual observation (inspection) quarterly in each of the following periods: January-March, April-June, July-September, and October-December. Visual observation (inspections) are only required during daylight hours (sunrise to sunset).
 - iii. Risk Level 1 dischargers shall ensure that visual observations (inspections) document the presence or evidence of any non-storm water discharge (authorized or unauthorized), pollutant characteristics (floating and suspended material, sheen, discoloration, turbidity, odor, etc.), and source. Risk Level 1 dischargers shall maintain on-site records indicating the personnel performing the visual observation (inspections), the dates and approximate time each drainage area and non-storm water discharge was observed, and the response taken to eliminate unauthorized non-storm water discharges and to reduce or prevent pollutants from contacting non-storm water discharges.

7. Risk Level 1 – Non-Visible Pollutant Monitoring Requirements

- a. Risk Level 1 dischargers shall collect one or more samples during any breach, malfunction, leakage, or spill observed during a visual inspection which could result in the discharge of pollutants to surface waters that would not be visually detectable in storm water.
- b. Risk Level 1 dischargers shall ensure that water samples are large enough to characterize the site conditions.
- c. Risk Level 1 dischargers shall collect samples at all discharge locations that can be safely accessed.
- d. Risk Level 1 dischargers shall collect samples during the first two hours of discharge from rain events that occur during business hours and which generate runoff.
- e. Risk Level 1 dischargers shall analyze samples for all non-visible pollutant parameters (if applicable) - parameters indicating the

presence of pollutants identified in the pollutant source assessment required (Risk Level 1 dischargers shall modify their CSMPs to address these additional parameters in accordance with any updated SWPPP pollutant source assessment).

- f. Risk Level 1 dischargers shall collect a sample of storm water that has not come in contact with the disturbed soil or the materials stored or used on-site (uncontaminated sample) for comparison with the discharge sample.
- g. Risk Level 1 dischargers shall compare the uncontaminated sample to the samples of discharge using field analysis or through laboratory analysis.²
- h. Risk Level 1 dischargers shall keep all field /or analytical data in the SWPPP document.

8. Risk Level 1 – Particle Size Analysis for Project Risk Justification

Risk Level 1 dischargers justifying an alternative project risk shall report a soil particle size analysis used to determine the RUSLE K-Factor. ASTM D-422 (Standard Test Method for Particle-Size Analysis of Soils), as revised, shall be used to determine the percentages of sand, very fine sand, silt, and clay on the site.

9. Risk Level 1 – Records

Risk Level 1 dischargers shall retain records of all storm water monitoring information and copies of all reports (including Annual Reports) for a period of at least three years. Risk Level 1 dischargers shall retain all records on-site while construction is ongoing. These records include:

- a. The date, place, time of facility inspections, sampling, visual observation (inspections), and/or measurements, including precipitation.
- b. The individual(s) who performed the facility inspections, sampling, visual observation (inspections), and or measurements.
- c. The date and approximate time of analyses.
- d. The individual(s) who performed the analyses.

² For laboratory analysis, all sampling, sample preservation, and analyses must be conducted according to test procedures under 40 CFR Part 136. Field discharge samples shall be collected and analyzed according to the specifications of the manufacturer of the sampling devices employed.

- e. A summary of all analytical results from the last three years, the method detection limits and reporting units, and the analytical techniques or methods used.
- f. Rain gauge readings from site inspections.
- g. Quality assurance/quality control records and results.
- h. Non-storm water discharge inspections and visual observation (inspections) and storm water discharge visual observation records (see Sections I.3 and I.6 above).
- i. Visual observation and sample collection exception records (see Section I.4 above).
- j. The records of any corrective actions and follow-up activities that resulted from analytical results, visual observation (inspections), or inspections.

This page intentionally left blank.

ATTACHMENT D RISK LEVEL 2 REQUIREMENTS

A. Effluent Standards

[These requirements are the same as those in the General Permit order.]

1. Narrative – Risk Level 2 dischargers shall comply with the narrative effluent standards listed below:
 - a. Storm water discharges and authorized non-storm water discharges regulated by this General Permit shall not contain a hazardous substance equal to or in excess of reportable quantities established in 40 C.F.R. §§ 117.3 and 302.4, unless a separate NPDES Permit has been issued to regulate those discharges.
 - b. Dischargers shall minimize or prevent pollutants in storm water discharges and authorized non-storm water discharges through the use of controls, structures, and management practices that achieve BAT for toxic and non-conventional pollutants and BCT for conventional pollutants.
2. Numeric – Risk level 2 dischargers are subject to a pH NAL of 6.5-8.5, and a turbidity NAL of 250 NTU.

B. Good Site Management "Housekeeping"

1. Risk Level 2 dischargers shall implement good site management (i.e., "housekeeping") measures for construction materials that could potentially be a threat to water quality if discharged. At a minimum, Risk Level 2 dischargers shall implement the following good housekeeping measures:
 - a. Conduct an inventory of the products used and/or expected to be used and the end products that are produced and/or expected to be produced. This does not include materials and equipment that are designed to be outdoors and exposed to environmental conditions (i.e. poles, equipment pads, cabinets, conductors, insulators, bricks, etc.).
 - b. Cover and berm loose stockpiled construction materials that are not actively being used (i.e. soil, spoils, aggregate, fly-ash, stucco, hydrated lime, etc.).

- c. Store chemicals in watertight containers (with appropriate secondary containment to prevent any spillage or leakage) or in a storage shed (completely enclosed).
 - d. Minimize exposure of construction materials to precipitation. This does not include materials and equipment that are designed to be outdoors and exposed to environmental conditions (i.e. poles, equipment pads, cabinets, conductors, insulators, bricks, etc.).
 - e. Implement BMPs to prevent the off-site tracking of loose construction and landscape materials.
2. Risk Level 2 dischargers shall implement good housekeeping measures for waste management, which, at a minimum, shall consist of the following:
- a. Prevent disposal of any rinse or wash waters or materials on impervious or pervious site surfaces or into the storm drain system.
 - b. Ensure the containment of sanitation facilities (e.g., portable toilets) to prevent discharges of pollutants to the storm water drainage system or receiving water.
 - c. Clean or replace sanitation facilities and inspecting them regularly for leaks and spills.
 - d. Cover waste disposal containers at the end of every business day and during a rain event.
 - e. Prevent discharges from waste disposal containers to the storm water drainage system or receiving water.
 - f. Contain and securely protect stockpiled waste material from wind and rain at all times unless actively being used.
 - g. Implement procedures that effectively address hazardous and non-hazardous spills.
 - h. Develop a spill response and implementation element of the SWPPP prior to commencement of construction activities. The SWPPP shall require:
 - i. Equipment and materials for cleanup of spills shall be available on site and that spills and leaks shall be cleaned up immediately and disposed of properly.

- ii. Appropriate spill response personnel are assigned and trained.
 - i. Ensure the containment of concrete washout areas and other washout areas that may contain additional pollutants so there is no discharge into the underlying soil and onto the surrounding areas.
3. Risk Level 2 dischargers shall implement good housekeeping for vehicle storage and maintenance, which, at a minimum, shall consist of the following:
 - a. Prevent oil, grease, or fuel to leak in to the ground, storm drains or surface waters.
 - b. Place all equipment or vehicles, which are to be fueled, maintained and stored in a designated area fitted with appropriate BMPs.
 - c. Clean leaks immediately and disposing of leaked materials properly.
4. Risk Level 2 dischargers shall implement good housekeeping for landscape materials, which, at a minimum, shall consist of the following:
 - a. Contain stockpiled materials such as mulches and topsoil when they are not actively being used.
 - b. Contain all fertilizers and other landscape materials when they are not actively being used.
 - c. Discontinue the application of any erodible landscape material within 2 days before a forecasted rain event or during periods of precipitation.
 - d. Apply erodible landscape material at quantities and application rates according to manufacture recommendations or based on written specifications by knowledgeable and experienced field personnel.
 - e. Stack erodible landscape material on pallets and covering or storing such materials when not being used or applied.
5. Risk Level 2 dischargers shall conduct an assessment and create a list of potential pollutant sources and identify any areas of the site where additional BMPs are necessary to reduce or prevent pollutants in storm water discharges and authorized non-storm water discharges. This potential pollutant list shall be kept with the SWPPP and shall identify

all non-visible pollutants which are known, or should be known, to occur on the construction site. At a minimum, when developing BMPs, Risk Level 2 dischargers shall do the following:

- a. Consider the quantity, physical characteristics (e.g., liquid, powder, solid), and locations of each potential pollutant source handled, produced, stored, recycled, or disposed of at the site.
 - b. Consider the degree to which pollutants associated with those materials may be exposed to and mobilized by contact with storm water.
 - c. Consider the direct and indirect pathways that pollutants may be exposed to storm water or authorized non-storm water discharges. This shall include an assessment of past spills or leaks, non-storm water discharges, and discharges from adjoining areas.
 - d. Ensure retention of sampling, visual observation, and inspection records.
 - e. Ensure effectiveness of existing BMPs to reduce or prevent pollutants in storm water discharges and authorized non-storm water discharges.
6. Risk Level 2 dischargers shall implement good housekeeping measures on the construction site to control the air deposition of site materials and from site operations. Such particulates can include, but are not limited to, sediment, nutrients, trash, metals, bacteria, oil and grease and organics.
 7. **Additional Risk Level 2 Requirement:** Risk Level 2 dischargers shall document all housekeeping BMPs in the SWPPP and REAP(s) in accordance with the nature and phase of the construction project. Construction phases at traditional land development projects include Grading and Land Development Phase, Streets and Utilities, or Vertical Construction for traditional land development projects.

C. Non-Storm Water Management

1. Risk Level 2 dischargers shall implement measures to control all non-storm water discharges during construction.
2. Risk Level 2 dischargers shall wash vehicles in such a manner as to prevent non-storm water discharges to surface waters or MS4 drainage systems.

3. Risk Level 2 dischargers shall clean streets in such a manner as to prevent unauthorized non-storm water discharges from reaching surface water or MS4 drainage systems.

D. Erosion Control

1. Risk Level 2 dischargers shall implement effective wind erosion control.
2. Risk Level 2 dischargers shall provide effective soil cover for inactive¹ areas and all finished slopes, open space, utility backfill, and completed lots.
3. Risk Level 2 dischargers shall limit the use of plastic materials when more sustainable, environmentally friendly alternatives exist. Where plastic materials are deemed necessary, the discharger shall consider the use of plastic materials resistant to solar degradation.

E. Sediment Controls

1. Risk Level 2 dischargers shall establish and maintain effective perimeter controls and stabilize all construction entrances and exits to sufficiently control erosion and sediment discharges from the site.
2. On sites where sediment basins are to be used, Risk Level 2 dischargers shall, at minimum, design sediment basins according to the method provided in CASQA's Construction BMP Guidance Handbook.
3. **Additional Risk Level 2 Requirement:** Risk Level 2 dischargers shall implement appropriate erosion control BMPs (runoff control and soil stabilization) in conjunction with sediment control BMPs for areas under active² construction.
4. **Additional Risk Level 2 Requirement:** Risk Level 2 dischargers shall apply linear sediment controls along the toe of the slope, face of the slope, and at the grade breaks of exposed slopes to comply with sheet flow lengths³ in accordance with Table 1.

¹ Inactive areas of construction are areas of construction activity that have been disturbed and are not scheduled to be re-disturbed for at least 14 days.

² Active areas of construction are areas undergoing land surface disturbance. This includes construction activity during the preliminary stage, mass grading stage, streets and utilities stage and the vertical construction stage.

³ Sheet flow length is the length that shallow, low velocity flow travels across a site.

Table 1 - Critical Slope/Sheet Flow Length Combinations

Slope Percentage	Sheet flow length not to exceed
0-25%	20 feet
25-50%	15 feet
Over 50%	10 feet

5. **Additional Risk Level 2 Requirement:** Risk Level 2 dischargers shall ensure that construction activity traffic to and from the project is limited to entrances and exits that employ effective controls to prevent offsite tracking of sediment.
6. **Additional Risk Level 2 Requirement:** Risk Level 2 dischargers shall ensure that all storm drain inlets and perimeter controls, runoff control BMPs, and pollutant controls at entrances and exits (e.g. tire washoff locations) are maintained and protected from activities that reduce their effectiveness.
7. **Additional Risk Level 2 Requirement:** Risk Level 2 dischargers shall inspect on a daily basis all immediate access roads daily. At a minimum daily (when necessary) and prior to any rain event, the discharger shall remove any sediment or other construction activity-related materials that are deposited on the roads (by vacuuming or sweeping).

F. Run-on and Run-off Controls

Risk Level 2 dischargers shall effectively manage all run-on, all runoff within the site and all runoff that discharges off the site. Run-on from off site shall be directed away from all disturbed areas or shall collectively be in compliance with the effluent limitations in this General Permit.

G. Inspection, Maintenance and Repair

1. Risk Level 2 dischargers shall ensure that all inspection, maintenance repair and sampling activities at the project location shall be performed or supervised by a Qualified SWPPP Practitioner (QSP) representing the discharger. The QSP may delegate any or all of these activities to an employee appropriately trained to do the task(s).
2. Risk Level 2 dischargers shall perform weekly inspections and observations, and at least once each 24-hour period during extended storm events, to identify and record BMPs that need maintenance to operate effectively, that have failed, or that could fail to operate as intended. Inspectors shall be the QSP or be trained by the QSP.

3. Upon identifying failures or other shortcomings, as directed by the QSP, Risk Level 2 dischargers shall begin implementing repairs or design changes to BMPs within 72 hours of identification and complete the changes as soon as possible.
4. For each inspection required, Risk Level 2 dischargers shall complete an inspection checklist, using a form provided by the State Water Board or Regional Water Board or in an alternative format.
5. Risk Level 2 dischargers shall ensure that checklists shall remain onsite with the SWPPP and at a minimum, shall include:
 - a. Inspection date and date the inspection report was written.
 - b. Weather information, including presence or absence of precipitation, estimate of beginning of qualifying storm event, duration of event, time elapsed since last storm, and approximate amount of rainfall in inches.
 - c. Site information, including stage of construction, activities completed, and approximate area of the site exposed.
 - d. A description of any BMPs evaluated and any deficiencies noted.
 - e. If the construction site is safely accessible during inclement weather, list the observations of all BMPs: erosion controls, sediment controls, chemical and waste controls, and non-storm water controls. Otherwise, list the results of visual inspections at all relevant outfalls, discharge points, downstream locations and any projected maintenance activities.
 - f. Report the presence of noticeable odors or of any visible sheen on the surface of any discharges.
 - g. Any corrective actions required, including any necessary changes to the SWPPP and the associated implementation dates.
 - h. Photographs taken during the inspection, if any.
 - i. Inspector's name, title, and signature.

H. Rain Event Action Plan

1. **Additional Risk Level 2 Requirement:** The discharger shall ensure a QSP develop a Rain Event Action Plan (REAP) 48 hours prior to any

likely precipitation event. A likely precipitation event is any weather pattern that is forecast to have a 50% or greater probability of producing precipitation in the project area. The discharger shall ensure a QSP obtain a printed copy of precipitation forecast information from the National Weather Service Forecast Office (e.g., by entering the zip code of the project's location at <http://www.srh.noaa.gov/forecast>).

2. **Additional Risk Level 2 Requirement:** The discharger shall ensure a QSP develop the REAPs for all phases of construction (i.e., Grading and Land Development, Streets and Utilities, Vertical Construction, Final Landscaping and Site Stabilization).
3. **Additional Risk Level 2 Requirement:** The discharger shall ensure a QSP ensure that the REAP include, at a minimum, the following site information:
 - a. Site Address
 - b. Calculated Risk Level (2 or 3)
 - c. Site Storm Water Manager Information including the name, company, and 24-hour emergency telephone number
 - d. Erosion and Sediment Control Provider information including the name, company, and 24-hour emergency telephone number
 - e. Storm Water Sampling Agent information including the name, company, and 24-hour emergency telephone number
4. **Additional Risk Level 2 Requirement:** The discharger shall ensure a QSP include in the REAP, at a minimum, the following project phase information:
 - a. Activities associated with each construction phase
 - b. Trades active on the construction site during each construction phase
 - c. Trade contractor information
 - d. Suggested actions for each project phase
5. **Additional Risk Level 2 Requirement:** The discharger shall ensure a QSP develop additional REAPs for project sites where construction activities are indefinitely halted or postponed (Inactive Construction). At a minimum, Inactive Construction REAPs must include:
 - a. Site Address
 - b. Calculated Risk Level (2 or 3)
 - c. Site Storm Water Manager Information including the name, company, and 24-hour emergency telephone number

- d. Erosion and Sediment Control Provider information including the name, company, and 24-hour emergency telephone number
 - e. Storm Water Sampling Agent information including the name, company, and 24-hour emergency telephone number
 - f. Trades active on site during Inactive Construction
 - g. Trade contractor information
 - h. Suggested actions for inactive construction sites
6. **Additional Risk Level 2 Requirement:** The discharger shall ensure a QSP begin implementation and make the REAP available onsite no later than 24 hours prior to the likely precipitation event.
7. **Additional Risk Level 2 Requirement:** The discharger shall ensure a QSP maintain onsite a paper copy of each REAP onsite in compliance with the record retention requirements of the Special Provisions in this General Permit.

I. Risk Level 2 Monitoring and Reporting Requirements

Table 2- Summary of Monitoring Requirements

Risk Level	Visual Inspections					Sample Collection	
	Quarterly Non-storm Water Discharge	Pre-storm Event		Daily Storm BMP	Post Storm	Storm Water Discharge	Receiving Water
		Baseline	REAP				
2	X	X	X	X	X	X	

1. Construction Site Monitoring Program Requirements

- a. Pursuant to Water Code Sections 13383 and 13267, all dischargers subject to this General Permit shall develop and implement a written site-specific Construction Site Monitoring Program (CSMP) in accordance with the requirements of this Section. The CSMP shall include all monitoring procedures and instructions, location maps, forms, and checklists as required in this section. The CSMP shall be developed prior to the commencement of construction activities, and revised as necessary to reflect project revisions. The CSMP shall be a part of the Storm Water Pollution Prevention Plan (SWPPP), included as an appendix or separate SWPPP chapter.
- b. Existing dischargers registered under the State Water Board Order No. 99-08-DWQ shall make and implement necessary revisions to their Monitoring Program to reflect the changes in this General Permit in a timely manner, but no later than July 1, 2010. Existing dischargers shall continue to implement their existing Monitoring Programs in compliance with State Water Board Order No. 99-08-DWQ until the necessary revisions are completed according to the schedule above.
- c. When a change of ownership occurs for all or any portion of the construction site prior to completion or final stabilization, the new discharger shall comply with these requirements as of the date the ownership change occurs.

2. Objectives

The CSMP shall be developed and implemented to address the following objectives:

- a. To demonstrate that the site is in compliance with the Discharge Prohibitions and applicable Numeric Action Levels (NALs).

- b. To determine whether non-visible pollutants are present at the construction site and are causing or contributing to exceedances of water quality objectives.
 - c. To determine whether immediate corrective actions, additional Best Management Practice (BMP) implementation, or SWPPP revisions are necessary to reduce pollutants in storm water discharges and authorized non-storm water discharges.
 - d. To determine whether BMPs included in the SWPPP/Rain Event Action Plan (REAP) are effective in preventing or reducing pollutants in storm water discharges and authorized non-storm water discharges.
- 3. Risk Level 2 – Visual Monitoring (Inspection) Requirements for Qualifying Rain Events**
- a. Risk Level 2 dischargers shall visually observe (inspect) storm water discharges at all discharge locations within two business days (48 hours) after each qualifying rain event.
 - b. Risk Level 2 dischargers shall visually observe (inspect) the discharge of stored or contained storm water that is derived from and discharged subsequent to a qualifying rain event producing precipitation of ½ inch or more at the time of discharge. Stored or contained storm water that will likely discharge after operating hours due to anticipated precipitation shall be observed prior to the discharge during operating hours.
 - c. Risk Level 2 dischargers shall conduct visual observations (inspections) during business hours only.
 - d. Risk Level 2 dischargers shall record the time, date and rain gauge reading of all qualifying rain events.
 - e. Within 2 business days (48 hours) prior to each qualifying rain event, Risk Level 2 dischargers shall visually observe (inspect):
 - i. all storm water drainage areas to identify any spills, leaks, or uncontrolled pollutant sources. If needed, the discharger shall implement appropriate corrective actions.
 - ii. all BMPs to identify whether they have been properly implemented in accordance with the SWPPP/REAP. If needed, the discharger shall implement appropriate corrective actions.

- iii. any storm water storage and containment areas to detect leaks and ensure maintenance of adequate freeboard.
- f. For the visual observations (inspections) described in c.i and c.iii above, Risk Level 2 dischargers shall observe the presence or absence of floating and suspended materials, a sheen on the surface, discolorations, turbidity, odors, and source(s) of any observed pollutants.
- g. Within two business days (48 hours) after each qualifying rain event, Risk Level 2 dischargers shall conduct post rain event visual observations (inspections) to (1) identify whether BMPs were adequately designed, implemented, and effective, and (2) identify additional BMPs and revise the SWPPP accordingly.
- h. Risk Level 2 dischargers shall maintain on-site records of all visual observations (inspections), personnel performing the observations, observation dates, weather conditions, locations observed, and corrective actions taken in response to the observations.

4. Risk Level 2 – Water Quality Sampling and Analysis

- a. Risk Level 2 dischargers shall collect storm water grab samples from sampling locations, as defined in Section I.5. The storm water grab sample(s) obtained shall be representative of the flow and characteristics of the discharge.
- b. At minimum, Risk Level 2 dischargers shall collect 3 samples per day of the qualifying event.
- c. Risk Level 2 dischargers shall ensure that the grab samples collected of stored or contained storm water are from discharges subsequent to a qualifying rain event (producing precipitation of ½ inch or more at the time of discharge).

Storm Water Effluent Monitoring Requirements

- d. Risk Level 2 dischargers shall analyze their effluent samples for:
 - i. pH and turbidity.
 - ii. Any additional parameters for which monitoring is required by the Regional Water Board.

5. Risk Level 2 – Storm Water Discharge Water Quality Sampling Locations

Effluent Sampling Locations

- a. Risk Level 2 dischargers shall perform sampling and analysis of storm water discharges to characterize discharges associated with construction activity from the entire project disturbed area.
- b. Risk Level 2 dischargers shall collect effluent samples at all discharge points where storm water is discharged off-site.
- c. Risk Level 2 dischargers shall ensure that storm water discharge collected and observed represent⁴ the effluent in each drainage area based on visual observation of the water and upstream conditions.
- d. Risk Level 2 dischargers shall monitor and report site run-on from surrounding areas if there is reason to believe run-on may contribute to an exceedance of NALs.
- e. Risk Level 2 dischargers who deploy an ATS on their site, or a portion on their site, shall collect ATS effluent samples and measurements from the discharge pipe or another location representative of the nature of the discharge.
- f. Risk Level 2 dischargers shall select analytical test methods from the list provided in Table 3 below.
- g. All storm water sample collection preservation and handling shall be conducted in accordance with Section I.7 “Storm Water Sample Collection and Handling Instructions” below.

6. Risk Level 2 – Visual Observation and Sample Collection Exemptions

- a. Risk Level 2 dischargers shall be prepared to collect samples and conduct visual observation (inspections) until the minimum requirements of Sections I.3 and I.4 above are completed. Risk Level 2 dischargers are not required to physically collect samples or conduct visual observation (inspections) under the following conditions:

⁴ For example, if there has been concrete work recently in an area, or drywall scrap is exposed to the rain, a pH sample shall be taken of drainage from the relevant work area. Similarly, if sediment laden water is flowing through some parts of a silt fence, samples shall be taken of the sediment-laden water even if most water flowing through the fence is clear.

- i. During dangerous weather conditions such as flooding and electrical storms.
 - ii. Outside of scheduled site business hours.
- b. If no required samples or visual observation (inspections) are collected due to these exceptions, Risk Level 2 dischargers shall include an explanation in their SWPPP and in the Annual Report documenting why the sampling or visual observation (inspections) were not conducted.
- 7. Risk Level 2 – Storm Water Sample Collection and Handling Instructions**
- a. Risk Level 2 dischargers shall refer to Table 3 below for test methods, detection limits, and reporting units.
 - b. Risk Level 2 dischargers shall ensure that testing laboratories will receive samples within 48 hours of the physical sampling (unless otherwise required by the laboratory), and shall use only the sample containers provided by the laboratory to collect and store samples.
 - c. Risk Level 2 dischargers shall designate and train personnel to collect, maintain, and ship samples in accordance with the Surface Water Ambient Monitoring Program's (SWAMP) 2008 Quality Assurance Program Plan (QAPrP).⁵

8. Risk Level 2 – Monitoring Methods

- a. Risk Level 2 dischargers shall include a description of the following items in the CSMP:
 - i. Visual observation locations, visual observation procedures, and visual observation follow-up and tracking procedures.
 - ii. Sampling locations, and sample collection and handling procedures. This shall include detailed procedures for sample collection, storage, preservation, and shipping to the testing lab to assure that consistent quality control and quality assurance is maintained. Dischargers shall attach to the monitoring program

⁵ Additional information regarding SWAMP's QAPrP can be found at http://www.waterboards.ca.gov/water_issues/programs/swamp/.
QAPrP:http://www.waterboards.ca.gov/water_issues/programs/swamp/docs/qapp/swamp_qapp_master090108a.pdf.

an example Chain of Custody form used when handling and shipping samples.

- iii. Identification of the analytical methods and related method detection limits (if applicable) for each parameter required in Section I.4 above.
- b. Risk Level 2 dischargers shall ensure that all sampling and sample preservation are in accordance with the current edition of "Standard Methods for the Examination of Water and Wastewater" (American Public Health Association). All monitoring instruments and equipment (including a discharger's own field instruments for measuring pH and turbidity) should be calibrated and maintained in accordance with manufacturers' specifications to ensure accurate measurements. Risk Level 2 dischargers shall ensure that all laboratory analyses are conducted according to test procedures under 40 CFR Part 136, unless other test procedures have been specified in this General Permit or by the Regional Water Board. With the exception of field analysis conducted by the discharger for turbidity and pH, all analyses should be sent to and conducted at a laboratory certified for such analyses by the State Department of Health Services. Risk Level 2 dischargers shall conduct their own field analysis of pH and may conduct their own field analysis of turbidity if the discharger has sufficient capability (qualified and trained employees, properly calibrated and maintained field instruments, etc.) to adequately perform the field analysis.

9. Risk Level 2 – Analytical Methods

- a. Risk Level 2 dischargers shall refer to Table 3 below for test methods, detection limits, and reporting units.
- b. **pH:** Risk Level 2 dischargers shall perform pH analysis on-site with a calibrated pH meter or a pH test kit. Risk Level 2 dischargers shall record pH monitoring results on paper and retain these records in accordance with Section I.14, below.
- c. **Turbidity:** Risk Level 2 dischargers shall perform turbidity analysis using a calibrated turbidity meter (turbidimeter), either on-site or at an accredited lab. Acceptable test methods include Standard Method 2130 or USEPA Method 180.1. The results will be recorded in the site log book in Nephelometric Turbidity Units (NTU).

10. Risk Level 2 - Non-Storm Water Discharge Monitoring Requirements

- a. Visual Monitoring Requirements:
- i. Risk Level 2 dischargers shall visually observe (inspect) each drainage area for the presence of (or indications of prior) unauthorized and authorized non-storm water discharges and their sources.
 - ii. Risk Level 2 dischargers shall conduct one visual observation (inspection) quarterly in each of the following periods: January-March, April-June, July-September, and October-December. Visual observation (inspections) are only required during daylight hours (sunrise to sunset).
 - iii. Risk Level 2 dischargers shall ensure that visual observations (inspections) document the presence or evidence of any non-storm water discharge (authorized or unauthorized), pollutant characteristics (floating and suspended material, sheen, discoloration, turbidity, odor, etc.), and source. Risk Level 2 dischargers shall maintain on-site records indicating the personnel performing the visual observation (inspections), the dates and approximate time each drainage area and non-storm water discharge was observed, and the response taken to eliminate unauthorized non-storm water discharges and to reduce or prevent pollutants from contacting non-storm water discharges.
- b. Effluent Sampling Locations:
- i. Risk Level 2 dischargers shall sample effluent at all discharge points where non-storm water and/or authorized non-storm water is discharged off-site.
 - ii. Risk Level 2 dischargers shall send all non-storm water sample analyses to a laboratory certified for such analyses by the State Department of Health Services.
 - iii. Risk Level 2 dischargers shall monitor and report run-on from surrounding areas if there is reason to believe run-on may contribute to an exceedance of NALs.

11. Risk Level 2 – Non-Visible Pollutant Monitoring Requirements

- a. Risk Level 2 dischargers shall collect one or more samples during any breach, malfunction, leakage, or spill observed during a visual

inspection which could result in the discharge of pollutants to surface waters that would not be visually detectable in storm water.

- b. Risk Level 2 dischargers shall ensure that water samples are large enough to characterize the site conditions.
- c. Risk Level 2 dischargers shall collect samples at all discharge locations that can be safely accessed.
- d. Risk Level 2 dischargers shall collect samples during the first two hours of discharge from rain events that occur during business hours and which generate runoff.
- e. Risk Level 2 dischargers shall analyze samples for all non-visible pollutant parameters (if applicable) - parameters indicating the presence of pollutants identified in the pollutant source assessment required (Risk Level 2 dischargers shall modify their CSMPs to address these additional parameters in accordance with any updated SWPPP pollutant source assessment).
- f. Risk Level 2 dischargers shall collect a sample of storm water that has not come in contact with the disturbed soil or the materials stored or used on-site (uncontaminated sample) for comparison with the discharge sample.
- g. Risk Level 2 dischargers shall compare the uncontaminated sample to the samples of discharge using field analysis or through laboratory analysis.⁶
- h. Risk Level 2 dischargers shall keep all field /or analytical data in the SWPPP document.

12. Risk Level 2 – Watershed Monitoring Option

Risk Level 2 dischargers who are part of a qualified regional watershed-based monitoring program may be eligible for relief from the requirements in Sections I.5. The Regional Water Board may approve proposals to substitute an acceptable watershed-based monitoring program by determining if the watershed-based monitoring program will provide substantially similar monitoring information in evaluating discharger compliance with the requirements of this General Permit.

⁶ For laboratory analysis, all sampling, sample preservation, and analyses must be conducted according to test procedures under 40 CFR Part 136. Field discharge samples shall be collected and analyzed according to the specifications of the manufacturer of the sampling devices employed.

13. Risk Level 2 – Particle Size Analysis for Project Risk Justification

Risk Level 2 dischargers justifying an alternative project risk shall report a soil particle size analysis used to determine the RUSLE K-Factor. ASTM D-422 (Standard Test Method for Particle-Size Analysis of Soils), as revised, shall be used to determine the percentages of sand, very fine sand, silt, and clay on the site.

14. Risk Level 2 – Records

Risk Level 2 dischargers shall retain records of all storm water monitoring information and copies of all reports (including Annual Reports) for a period of at least three years. Risk Level 2 dischargers shall retain all records on-site while construction is ongoing. These records include:

- a. The date, place, time of facility inspections, sampling, visual observation (inspections), and/or measurements, including precipitation.
- b. The individual(s) who performed the facility inspections, sampling, visual observation (inspections), and or measurements.
- c. The date and approximate time of analyses.
- d. The individual(s) who performed the analyses.
- e. A summary of all analytical results from the last three years, the method detection limits and reporting units, the analytical techniques or methods used, and the chain of custody forms.
- f. Rain gauge readings from site inspections;
- g. Quality assurance/quality control records and results.
- h. Non-storm water discharge inspections and visual observation (inspections) and storm water discharge visual observation records (see Sections I.3 and I.10 above).
- i. Visual observation and sample collection exception records (see Section I.6 above).
- j. The records of any corrective actions and follow-up activities that resulted from analytical results, visual observation (inspections), or inspections.

15. Risk Level 2 – NAL Exceedance Report

- a. In the event that any effluent sample exceeds an applicable NAL, Risk Level 2 dischargers shall electronically submit all storm event sampling results to the State Water Board no later than 10 days after the conclusion of the storm event. The Regional Boards have the authority to require the submittal of an NAL Exceedance Report.
- b. Risk Level 2 dischargers shall certify each NAL Exceedance Report in accordance with the Special Provisions for Construction Activity.
- c. Risk Level 2 dischargers shall retain an electronic or paper copy of each NAL Exceedance Report for a minimum of three years after the date the annual report is filed.
- d. Risk Level 2 dischargers shall include in the NAL Exceedance Report:
 - i. The analytical method(s), method reporting unit(s), and method detection limit(s) of each analytical parameter (analytical results that are less than the method detection limit shall be reported as “less than the method detection limit”).
 - ii. The date, place, time of sampling, visual observation (inspections), and/or measurements, including precipitation.
 - iii. A description of the current BMPs associated with the effluent sample that exceeded the NAL and the proposed corrective actions taken.

Table 3 – Risk Level 2 Test Methods, Detection Limits, Reporting Units and Applicable NALs/NELs

Parameter	Test Method / Protocol	Discharge Type	Min. Detection Limit	Reporting Units	Numeric Action Level
pH	Field test with calibrated portable instrument	Risk Level 2 Discharges	0.2	pH units	lower NAL = 6.5 upper NAL = 8.5
Turbidity	EPA 0180.1 and/or field test with calibrated portable instrument	Risk Level 2 Discharges other than ATS	1	NTU	250 NTU
		For ATS discharges	1	NTU	N/A

ATTACHMENT E RISK LEVEL 3 REQUIREMENTS

A. Effluent Standards

[These requirements are the same as those in the General Permit order.]

1. Narrative – Risk Level 3 dischargers shall comply with the narrative effluent standards listed below:
 - a. Storm water discharges and authorized non-storm water discharges regulated by this General Permit shall not contain a hazardous substance equal to or in excess of reportable quantities established in 40 C.F.R. §§ 117.3 and 302.4, unless a separate NPDES Permit has been issued to regulate those discharges.
 - b. Dischargers shall minimize or prevent pollutants in storm water discharges and authorized non-storm water discharges through the use of controls, structures, and management practices that achieve BAT for toxic and non-conventional pollutants and BCT for conventional pollutants.
2. Numeric –Risk Level 3 dischargers are subject to a pH NAL of 6.5-8.5, and a turbidity NAL of 250 NTU.

B. Good Site Management "Housekeeping"

1. Risk Level 3 dischargers shall implement good site management (i.e., "housekeeping") measures for construction materials that could potentially be a threat to water quality if discharged. At a minimum, Risk Level 3 dischargers shall implement the following good housekeeping measures:
 - a. Conduct an inventory of the products used and/or expected to be used and the end products that are produced and/or expected to be produced. This does not include materials and equipment that are designed to be outdoors and exposed to environmental conditions (i.e. poles, equipment pads, cabinets, conductors, insulators, bricks, etc.).
 - b. Cover and berm loose stockpiled construction materials that are not actively being used (i.e. soil, spoils, aggregate, fly-ash, stucco, hydrated lime, etc.).

- c. Store chemicals in watertight containers (with appropriate secondary containment to prevent any spillage or leakage) or in a storage shed (completely enclosed).
 - d. Minimize exposure of construction materials to precipitation. This does not include materials and equipment that are designed to be outdoors and exposed to environmental conditions (i.e. poles, equipment pads, cabinets, conductors, insulators, bricks, etc.).
 - e. Implement BMPs to prevent the off-site tracking of loose construction and landscape materials.
2. Risk Level 3 dischargers shall implement good housekeeping measures for waste management, which, at a minimum, shall consist of the following:
- a. Prevent disposal of any rinse or wash waters or materials on impervious or pervious site surfaces or into the storm drain system.
 - b. Ensure the containment of sanitation facilities (e.g., portable toilets) to prevent discharges of pollutants to the storm water drainage system or receiving water.
 - c. Clean or replace sanitation facilities and inspecting them regularly for leaks and spills.
 - d. Cover waste disposal containers at the end of every business day and during a rain event.
 - e. Prevent discharges from waste disposal containers to the storm water drainage system or receiving water.
 - f. Contain and securely protecting stockpiled waste material from wind and rain at all times unless actively being used.
 - g. Implement procedures that effectively address hazardous and non-hazardous spills.
 - h. Develop a spill response and implementation element of the SWPPP prior to commencement of construction activities. The SWPPP shall require that:
 - i. Equipment and materials for cleanup of spills shall be available on site and that spills and leaks shall be cleaned up immediately and disposed of properly; and

- ii. Appropriate spill response personnel are assigned and trained.
 - i. Ensure the containment of concrete washout areas and other washout areas that may contain additional pollutants so there is no discharge into the underlying soil and onto the surrounding areas.
3. Risk Level 3 dischargers shall implement good housekeeping for vehicle storage and maintenance, which, at a minimum, shall consist of the following:
- a. Prevent oil, grease, or fuel to leak in to the ground, storm drains or surface waters.
 - b. Place all equipment or vehicles, which are to be fueled, maintained and stored in a designated area fitted with appropriate BMPs.
 - c. Clean leaks immediately and disposing of leaked materials properly.
4. Risk Level 3 dischargers shall implement good housekeeping for landscape materials, which, at a minimum, shall consist of the following:
- a. Contain stockpiled materials such as mulches and topsoil when they are not actively being used.
 - b. Contain fertilizers and other landscape materials when they are not actively being used.
 - c. Discontinuing the application of any erodible landscape material within 2 days before a forecasted rain event or during periods of precipitation.
 - d. Applying erodible landscape material at quantities and application rates according to manufacture recommendations or based on written specifications by knowledgeable and experienced field personnel.
 - e. Stacking erodible landscape material on pallets and covering or storing such materials when not being used or applied.
5. Risk Level 3 dischargers shall conduct an assessment and create a list of potential pollutant sources and identify any areas of the site where additional BMPs are necessary to reduce or prevent pollutants in storm water discharges and authorized non-storm water discharges. This potential pollutant list shall be kept with the SWPPP and shall identify

all non-visible pollutants which are known, or should be known, to occur on the construction site. At a minimum, when developing BMPs, Risk Level 3 dischargers shall do the following:

- a. Consider the quantity, physical characteristics (e.g., liquid, powder, solid), and locations of each potential pollutant source handled, produced, stored, recycled, or disposed of at the site.
 - b. Consider the degree to which pollutants associated with those materials may be exposed to and mobilized by contact with storm water.
 - c. Consider the direct and indirect pathways that pollutants may be exposed to storm water or authorized non-storm water discharges. This shall include an assessment of past spills or leaks, non-storm water discharges, and discharges from adjoining areas.
 - d. Ensure retention of sampling, visual observation, and inspection records.
 - e. Ensure effectiveness of existing BMPs to reduce or prevent pollutants in storm water discharges and authorized non-storm water discharges.
6. Risk Level 3 dischargers shall implement good housekeeping measures on the construction site to control the air deposition of site materials and from site operations. Such particulates can include, but are not limited to, sediment, nutrients, trash, metals, bacteria, oil and grease and organics.
7. **Additional Risk Level 3 Requirement:** Risk Level 3 dischargers shall document all housekeeping BMPs in the SWPPP and REAP(s) in accordance with the nature and phase of the construction project. Construction phases at traditional land development projects include Grading and Land Development Phase, Streets and Utilities, or Vertical Construction for traditional land development projects.

C. Non-Storm Water Management

1. Risk Level 3 dischargers shall implement measures to control all non-storm water discharges during construction.
2. Risk Level 3 dischargers shall wash vehicles in such a manner as to prevent non-storm water discharges to surface waters or MS4 drainage systems.

3. Risk Level 3 dischargers shall clean streets in such a manner as to prevent unauthorized non-storm water discharges from reaching surface water or MS4 drainage systems.

D. Erosion Control

1. Risk Level 3 dischargers shall implement effective wind erosion control.
2. Risk Level 3 dischargers shall provide effective soil cover for inactive¹ areas and all finished slopes, open space, utility backfill, and completed lots.
3. Dischargers shall limit the use of plastic materials when more sustainable, environmentally friendly alternatives exist. Where plastic materials are deemed necessary, the discharger shall consider the use of plastic materials resistant to solar degradation.

E. Sediment Controls

1. Risk Level 3 dischargers shall establish and maintain effective perimeter controls and stabilize all construction entrances and exits to sufficiently control erosion and sediment discharges from the site.
2. On sites where sediment basins are to be used, Risk Level 3 dischargers shall, at minimum, design sediment basins according to the method provided in CASQA's Construction BMP Guidance Handbook.
3. **Additional Risk Level 3 Requirement:** Risk Level 3 dischargers shall implement appropriate erosion control BMPs (runoff control and soil stabilization) in conjunction with sediment control BMPs for areas under active² construction.
4. **Additional Risk Level 3 Requirement:** Risk Level 3 dischargers shall apply linear sediment controls along the toe of the slope, face of the slope, and at the grade breaks of exposed slopes to comply with sheet flow lengths³ in accordance with Table 1.

¹ Inactive areas of construction are areas of construction activity that have been disturbed and are not scheduled to be re-disturbed for at least 14 days.

² Active areas of construction are areas undergoing land surface disturbance. This includes construction activity during the preliminary stage, mass grading stage, streets and utilities stage and the vertical construction stage

³ Sheet flow length is the length that shallow, low velocity flow travels across a site.

Table 1 - Critical Slope/Sheet Flow Length Combinations

Slope Percentage	Sheet flow length not to exceed
0-25%	20 feet
25-50%	15 feet
Over 50%	10 feet

5. **Additional Risk Level 3 Requirement:** Risk Level 3 dischargers shall ensure that construction activity traffic to and from the project is limited to entrances and exits that employ effective controls to prevent offsite tracking of sediment.
6. **Additional Risk Level 3 Requirement:** Risk Level 3 dischargers shall ensure that all storm drain inlets and perimeter controls, runoff control BMPs, and pollutant controls at entrances and exits (e.g. tire washoff locations) are maintained and protected from activities that reduce their effectiveness.
7. **Additional Risk Level 3 Requirement:** Risk Level 3 dischargers shall inspect on a daily basis all immediate access roads daily. At a minimum daily (when necessary) and prior to any rain event, the discharger shall remove any sediment or other construction activity-related materials that are deposited on the roads (by vacuuming or sweeping).
8. **Additional Risk Level 3 Requirement:** The Regional Water Board may require Risk Level 3 dischargers to implement additional site-specific sediment control requirements if the implementation of the other requirements in this section are not adequately protecting the receiving waters.

F. Run-on and Run-off Controls

Risk Level 3 dischargers shall effectively manage all run-on, all runoff within the site and all runoff that discharges off the site. Run-on from off site shall be directed away from all disturbed areas or shall collectively be in compliance with the effluent limitations in this General Permit.

G. Inspection, Maintenance and Repair

1. Risk Level 3 dischargers shall ensure that all inspection, maintenance repair and sampling activities at the project location shall be performed or supervised by a Qualified SWPPP Practitioner (QSP) representing the discharger. The QSP may delegate any or all of these activities to an employee appropriately trained to do the task(s).

2. Risk Level 3 dischargers shall perform weekly inspections and observations, and at least once each 24-hour period during extended storm events, to identify and record BMPs that need maintenance to operate effectively, that have failed, or that could fail to operate as intended. Inspectors shall be the QSP or be trained by the QSP.
3. Upon identifying failures or other shortcomings, as directed by the QSP, Risk Level 3 dischargers shall begin implementing repairs or design changes to BMPs within 72 hours of identification and complete the changes as soon as possible.
4. For each inspection required, Risk Level 3 dischargers shall complete an inspection checklist, using a form provided by the State Water Board or Regional Water Board or in an alternative format.
5. Risk Level 3 dischargers shall ensure that checklists shall remain onsite with the SWPPP and at a minimum, shall include:
 - a. Inspection date and date the inspection report was written.
 - b. Weather information, including presence or absence of precipitation, estimate of beginning of qualifying storm event, duration of event, time elapsed since last storm, and approximate amount of rainfall in inches.
 - c. Site information, including stage of construction, activities completed, and approximate area of the site exposed.
 - d. A description of any BMPs evaluated and any deficiencies noted.
 - e. If the construction site is safely accessible during inclement weather, list the observations of all BMPs: erosion controls, sediment controls, chemical and waste controls, and non-storm water controls. Otherwise, list the results of visual inspections at all relevant outfalls, discharge points, downstream locations and any projected maintenance activities.
 - f. Report the presence of noticeable odors or of any visible sheen on the surface of any discharges.
 - g. Any corrective actions required, including any necessary changes to the SWPPP and the associated implementation dates.
 - h. Photographs taken during the inspection, if any.

- i. Inspector's name, title, and signature.

H. Rain Event Action Plan

1. **Additional Risk Level 3 Requirement:** The discharger shall ensure a QSP develop a Rain Event Action Plan (REAP) 48 hours prior to any likely precipitation event. A likely precipitation event is any weather pattern that is forecast to have a 50% or greater probability of producing precipitation in the project area. The QSP shall obtain a printed copy of precipitation forecast information from the National Weather Service Forecast Office (e.g., by entering the zip code of the project's location at <http://www.srh.noaa.gov/forecast>).
2. **Additional Risk Level 3 Requirement:** The discharger shall ensure a QSP develop the REAPs for all phases of construction (i.e., Grading and Land Development, Streets and Utilities, Vertical Construction, Final Landscaping and Site Stabilization).
3. **Additional Risk Level 3 Requirement:** The discharger shall ensure a QSP ensure that the REAP include, at a minimum, the following site information:
 - a. Site Address.
 - b. Calculated Risk Level (2 or 3).
 - c. Site Storm Water Manager Information including the name, company, and 24-hour emergency telephone number.
 - d. Erosion and Sediment Control Provider information including the name, company, and 24-hour emergency telephone number.
 - e. Storm Water Sampling Agent information including the name, company, and 24-hour emergency telephone number.
4. **Additional Risk Level 3 Requirement:** The QSP shall include in the REAP, at a minimum, the following project phase information:
 - a. Activities associated with each construction phase.
 - b. Trades active on the construction site during each construction phase.
 - c. Trade contractor information.
 - d. Suggested actions for each project phase.
5. **Additional Risk Level 3 Requirement:** The QSP shall develop additional REAPs for project sites where construction activities are indefinitely halted or postponed (Inactive Construction). At a minimum, Inactive Construction REAPs must include:

- a. Site Address.
 - b. Calculated Risk Level (2 or 3).
 - c. Site Storm Water Manager Information including the name, company, and 24-hour emergency telephone number.
 - d. Erosion and Sediment Control Provider information including the name, company, and 24-hour emergency telephone number.
 - e. Storm Water Sampling Agent information including the name, company, and 24-hour emergency telephone number.
 - f. Trades active on site during Inactive Construction.
 - g. Trade contractor information.
 - h. Suggested actions for inactive construction sites.
6. **Additional Risk Level 3 Requirement:** The discharger shall ensure a QSP begin implementation and make the REAP available onsite no later than 24 hours prior to the likely precipitation event.
7. **Additional Risk Level 3 Requirement:** The discharger shall ensure a QSP maintain onsite a paper copy of each REAP onsite in compliance with the record retention requirements of the Special Provisions in this General Permit.

I. Risk Level 3 Monitoring and Reporting Requirements

Table 2- Summary of Monitoring Requirements

Risk Level	Visual Inspections					Sample Collection	
	Quarterly Non-storm Water Discharge	Pre-storm Event		Daily Storm BMP	Post Storm	Storm Water Discharge	Receiving Water
		Baseline	REAP				
3	X	X	X	X	X	X	X⁴

1. Construction Site Monitoring Program Requirements

- a. Pursuant to Water Code Sections 13383 and 13267, all dischargers subject to this General Permit shall develop and implement a written site-specific Construction Site Monitoring Program (CSMP) in accordance with the requirements of this Section. The CSMP shall include all monitoring procedures and instructions, location maps, forms, and checklists as required in this section. The CSMP shall be developed prior to the commencement of construction activities, and revised as necessary to reflect project revisions. The CSMP shall be a part of the Storm Water Pollution Prevention Plan (SWPPP), included as an appendix or separate SWPPP chapter.
- b. Existing dischargers registered under the State Water Board Order No. 99-08-DWQ shall make and implement necessary revisions to their Monitoring Program to reflect the changes in this General Permit in a timely manner, but no later than July 1, 2010. Existing dischargers shall continue to implement their existing Monitoring Program in compliance with State Water Board Order No. 99-08-DWQ until the necessary revisions are completed according to the schedule above.
- c. When a change of ownership occurs for all or any portion of the construction site prior to completion or final stabilization, the new discharger shall comply with these requirements as of the date the ownership change occurs.

2. Objectives

The CSMP shall be developed and implemented to address the following objectives:

⁴ When receiving water monitoring trigger is exceeded

- a. To demonstrate that the site is in compliance with the Discharge Prohibitions and applicable Numeric Action Levels (NALs) of this General Permit.
 - b. To determine whether non-visible pollutants are present at the construction site and are causing or contributing to exceedances of water quality objectives.
 - c. To determine whether immediate corrective actions, additional Best Management Practice (BMP) implementation, or SWPPP revisions are necessary to reduce pollutants in storm water discharges and authorized non-storm water discharges.
 - d. To determine whether BMPs included in the SWPPP/Rain Event Action Plan (REAP) are effective in preventing or reducing pollutants in storm water discharges and authorized non-storm water discharges.
- 3. Risk Level 3 – Visual Monitoring (Inspection) Requirements for Qualifying Rain Events**
- a. Risk Level 3 dischargers shall visually observe (inspect) storm water discharges at all discharge locations within two business days (48 hours) after each qualifying rain event.
 - b. Risk Level 3 dischargers shall visually observe (inspect) the discharge of stored or contained storm water that is derived from and discharged subsequent to a qualifying rain event producing precipitation of ½ inch or more at the time of discharge. Stored or contained storm water that will likely discharge after operating hours due to anticipated precipitation shall be observed prior to the discharge during operating hours.
 - c. Risk Level 3 dischargers shall conduct visual observations (inspections) during business hours only.
 - d. Risk Level 3 dischargers shall record the time, date and rain gauge reading of all qualifying rain events.
 - e. Within 2 business days (48 hours) prior to each qualifying rain event, Risk Level 3 dischargers shall visually observe (inspect):
 - i. all storm water drainage areas to identify any spills, leaks, or uncontrolled pollutant sources. If needed, the discharger shall implement appropriate corrective actions.

- ii. all BMPs to identify whether they have been properly implemented in accordance with the SWPPP/REAP. If needed, the discharger shall implement appropriate corrective actions.
 - iii. any storm water storage and containment areas to detect leaks and ensure maintenance of adequate freeboard.
- f. For the visual observations (inspections) described in c.i. and c.iii above, Risk Level 3 dischargers shall observe the presence or absence of floating and suspended materials, a sheen on the surface, discolorations, turbidity, odors, and source(s) of any observed pollutants.
 - g. Within two business days (48 hours) after each qualifying rain event, Risk Level 3 dischargers shall conduct post rain event visual observations (inspections) to (1) identify whether BMPs were adequately designed, implemented, and effective, and (2) identify additional BMPs and revise the SWPPP accordingly.
 - h. Risk Level 3 dischargers shall maintain on-site records of all visual observations (inspections), personnel performing the observations, observation dates, weather conditions, locations observed, and corrective actions taken in response to the observations.

4. Risk Level 3 – Water Quality Sampling and Analysis

- a. Risk Level 3 dischargers shall collect storm water grab samples from sampling locations, as defined in Section I.5. The storm water grab sample(s) obtained shall be representative of the flow and characteristics of the discharge.
- b. At minimum, Risk Level 3 dischargers shall collect 3 samples per day of the qualifying event.
- c. Risk Level 3 dischargers shall ensure that the grab samples collected of stored or contained storm water are from discharges subsequent to a qualifying rain event (producing precipitation of ½ inch or more at the time of discharge).

Storm Water Effluent Monitoring Requirements

- d. Risk Level 3 dischargers shall analyze their effluent samples for:
 - i. pH and turbidity.

- ii. Any additional parameters for which monitoring is required by the Regional Water Board.
- e. Risk 3 dischargers shall electronically submit all storm event sampling results to the State Water Board no later than 10 days after the conclusion of the storm event.

Receiving Water Monitoring Requirements

- f. In the event that a Risk Level 3 discharger's effluent exceeds the daily average receiving water monitoring trigger of 500 NTU turbidity or the daily average pH range 6.0-9.0 contained in this General Permit and has a direct discharge into receiving waters, the Risk Level 3 discharger shall subsequently sample receiving waters (RWs) for turbidity, pH (if applicable), and SSC for the duration of coverage under this General Permit. If a Risk Level 3 discharger utilizing ATS with direct discharges into receiving waters discharges effluent that exceeds the NELs in this permit, the discharger shall subsequently sample RWs for turbidity, pH (if applicable), and SSC for the duration of coverage under this General Permit.
 - g. Risk Level 3 dischargers disturbing 30 acres or more of the landscape and with direct discharges into receiving waters shall conduct or participate in benthic macroinvertebrate bioassessment of RWs prior to commencement of construction activity (See Appendix 3).
 - h. Risk Level 3 dischargers shall obtain RW samples in accordance with the Receiving Water sampling location section (Section I.5), below.
- 5. Risk Level 3 – Storm Water Discharge Water Quality Sampling Locations**

Effluent Sampling Locations

- a. Risk Level 3 dischargers shall perform sampling and analysis of storm water discharges to characterize discharges associated with construction activity from the entire project disturbed area.
- b. Risk Level 3 dischargers shall collect effluent samples at all discharge points where storm water is discharged off-site.

- c. Risk Level 3 dischargers shall ensure that storm water discharge collected and observed represent⁵ the effluent in each drainage area based on visual observation of the water and upstream conditions.
- d. Risk Level 3 dischargers shall monitor and report site run-on from surrounding areas if there is reason to believe run-on may contribute to an exceedance of NALs.
- e. Risk Level 3 dischargers who deploy an ATS on their site, or a portion on their site, shall collect ATS effluent samples and measurements from the discharge pipe or another location representative of the nature of the discharge.
- f. Risk Level 3 dischargers shall select analytical test methods from the list provided in Table 3 below.
- g. All storm water sample collection preservation and handling shall be conducted in accordance with Section 1.7 “Storm Water Sample Collection and Handling Instructions” below.

Receiving Water Sampling Locations

- h. **Upstream/up-gradient RW samples:** Risk Level 3 dischargers shall obtain any required upstream/up-gradient receiving water samples from a representative and accessible location as close as possible and upstream from the effluent discharge point.
- i. **Downstream/down-gradient RW samples:** Risk Level 3 dischargers shall obtain any required downstream/down-gradient receiving water samples from a representative and accessible location as close as possible and downstream from the effluent discharge point.
- j. If two or more discharge locations discharge to the same receiving water, Risk Level 3 dischargers may sample the receiving water at a single upstream and downstream location.

⁵ For example, if there has been concrete work recently in an area, or drywall scrap is exposed to the rain, a pH sample shall be taken of drainage from the relevant work area. Similarly, if sediment-laden water is flowing through some parts of a silt fence, samples shall be taken of the sediment laden water even if most water flowing through the fence is clear.

6. Risk Level 3 – Visual Observation and Sample Collection Exemptions

- a. Risk Level 3 dischargers shall be prepared to collect samples and conduct visual observation (inspections) until the minimum requirements of Sections I.3 and I.4 above are completed. Risk Level 3 dischargers are not required to physically collect samples or conduct visual observation (inspections) under the following conditions:
 - i. During dangerous weather conditions such as flooding and electrical storms.
 - ii. Outside of scheduled site business hours.
- b. If no required samples or visual observation (inspections) are collected due to these exceptions, Risk Level 3 dischargers shall include an explanation in their SWPPP and in the Annual Report documenting why the sampling or visual observation (inspections) were not conducted.

7. Risk Level 3 – Storm Water Sample Collection and Handling Instructions

- a. Risk Level 3 dischargers shall refer to Table 3 below for test methods, detection limits, and reporting units.
- b. Risk Level 3 dischargers shall ensure that testing laboratories will receive samples within 48 hours of the physical sampling (unless otherwise required by the laboratory), and shall use only the sample containers provided by the laboratory to collect and store samples.
- c. Risk Level 3 dischargers shall designate and train personnel to collect, maintain, and ship samples in accordance with the Surface Water Ambient Monitoring Program's (SWAMP) 2008 Quality Assurance Program Plan (QAPrP).⁶

⁶ Additional information regarding SWAMP's QAPrP can be found at http://www.waterboards.ca.gov/water_issues/programs/swamp/.

QAPrP:http://www.waterboards.ca.gov/water_issues/programs/swamp/docs/qapp/swamp_qapp_master090108a.pdf

8. Risk Level 3 – Monitoring Methods

- a. Risk Level 3 dischargers shall include a description of the following items in the CSMP:
 - i. Visual observation locations, visual observation procedures, and visual observation follow-up and tracking procedures.
 - ii. Sampling locations, and sample collection and handling procedures. This shall include detailed procedures for sample collection, storage, preservation, and shipping to the testing lab to assure that consistent quality control and quality assurance is maintained. Dischargers shall attach to the monitoring program an example Chain of Custody form used when handling and shipping samples.
 - iii. Identification of the analytical methods and related method detection limits (if applicable) for each parameter required in Section I.4 above.
- b. Risk Level 3 dischargers shall ensure that all sampling and sample preservation are in accordance with the current edition of "Standard Methods for the Examination of Water and Wastewater" (American Public Health Association). All monitoring instruments and equipment (including a discharger's own field instruments for measuring pH and turbidity) should be calibrated and maintained in accordance with manufacturers' specifications to ensure accurate measurements. Risk Level 3 dischargers shall ensure that all laboratory analyses are conducted according to test procedures under 40 CFR Part 136, unless other test procedures have been specified in this General Permit or by the Regional Water Board. With the exception of field analysis conducted by the discharger for turbidity and pH, all analyses should be sent to and conducted at a laboratory certified for such analyses by the State Department of Health Services (SSC exception). Risk Level 3 dischargers shall conduct their own field analysis of pH and may conduct their own field analysis of turbidity if the discharger has sufficient capability (qualified and trained employees, properly calibrated and maintained field instruments, etc.) to adequately perform the field analysis.

9. Risk Level 3 – Analytical Methods

- a. Risk Level 3 dischargers shall refer to Table 3 below for test methods, detection limits, and reporting units.

- b. **pH:** Risk Level 3 dischargers shall perform pH analysis on-site with a calibrated pH meter or a pH test kit. Risk Level 3 dischargers shall record pH monitoring results on paper and retain these records in accordance with Section I.14, below.
- c. **Turbidity:** Risk Level 3 dischargers shall perform turbidity analysis using a calibrated turbidity meter (turbidimeter), either on-site or at an accredited lab. Acceptable test methods include Standard Method 2130 or USEPA Method 180.1. The results will be recorded in the site log book in Nephelometric Turbidity Units (NTU).
- d. **Suspended sediment concentration (SSC):** Risk Level 3 dischargers that exceed the turbidity Receiving Water Monitoring Trigger shall perform SSC analysis using ASTM Method D3977-97.
- e. **Bioassessment:** Risk Level 3 dischargers shall perform bioassessment sampling and analysis according to Appendix 3 of this General Permit.

10. Risk Level 3 - Non-Storm Water Discharge Monitoring Requirements

- a. Visual Monitoring Requirements:
 - i. Risk Level 3 dischargers shall visually observe (inspect) each drainage area for the presence of (or indications of prior) unauthorized and authorized non-storm water discharges and their sources.
 - ii. Risk Level 3 dischargers shall conduct one visual observation (inspection) quarterly in each of the following periods: January-March, April-June, July-September, and October-December. Visual observation (inspections) are only required during daylight hours (sunrise to sunset).
 - iii. Risk Level 3 dischargers shall ensure that visual observations (inspections) document the presence or evidence of any non-storm water discharge (authorized or unauthorized), pollutant characteristics (floating and suspended material, sheen, discoloration, turbidity, odor, etc.), and source. Risk Level 3 dischargers shall maintain on-site records indicating the personnel performing the visual observation (inspections), the dates and approximate time each drainage area and non-storm water discharge was observed, and the response taken to eliminate unauthorized non-storm water discharges and to

reduce or prevent pollutants from contacting non-storm water discharges.

- b. Effluent Sampling Locations:
 - i. Risk Level 3 dischargers shall sample effluent at all discharge points where non-storm water and/or authorized non-storm water is discharged off-site.
 - ii. Risk Level 3 dischargers shall send all non-storm water sample analyses to a laboratory certified for such analyses by the State Department of Health Services.
 - iii. Risk Level 3 dischargers shall monitor and report run-on from surrounding areas if there is reason to believe run-on may contribute to an exceedance of NALs.

11. Risk Level 3 – Non-Visible Pollutant Monitoring Requirements

- a. Risk Level 3 dischargers shall collect one or more samples during any breach, malfunction, leakage, or spill observed during a visual inspection which could result in the discharge of pollutants to surface waters that would not be visually detectable in storm water.
- b. Risk Level 3 dischargers shall ensure that water samples are large enough to characterize the site conditions.
- c. Risk Level 3 dischargers shall collect samples at all discharge locations that can be safely accessed.
- d. Risk Level 3 dischargers shall collect samples during the first two hours of discharge from rain events that occur during business hours and which generate runoff.
- e. Risk Level 3 dischargers shall analyze samples for all non-visible pollutant parameters (if applicable) - parameters indicating the presence of pollutants identified in the pollutant source assessment required (Risk Level 3 dischargers shall modify their CSMPs to address these additional parameters in accordance with any updated SWPPP pollutant source assessment).
- f. Risk Level 3 dischargers shall collect a sample of storm water that has not come in contact with the disturbed soil or the materials stored or used on-site (uncontaminated sample) for comparison with the discharge sample.

- g. Risk Level 3 dischargers shall compare the uncontaminated sample to the samples of discharge using field analysis or through laboratory analysis.⁷
- h. Risk Level 3 dischargers shall keep all field /or analytical data in the SWPPP document.

12. Risk Level 3 – Watershed Monitoring Option

Risk Level 3 dischargers who are part of a qualified regional watershed-based monitoring program may be eligible for relief from the requirements in Sections I.5. The Regional Water Board may approve proposals to substitute an acceptable watershed-based monitoring program by determining if the watershed-based monitoring program will provide substantially similar monitoring information in evaluating discharger compliance with the requirements of this General Permit.

13. Risk Level 3 – Particle Size Analysis for Project Risk Justification

Risk Level 3 dischargers justifying an alternative project risk shall report a soil particle size analysis used to determine the RUSLE K-Factor. ASTM D-422 (Standard Test Method for Particle-Size Analysis of Soils), as revised, shall be used to determine the percentages of sand, very fine sand, silt, and clay on the site.

14. Risk Level 3 – Records

Risk Level 3 dischargers shall retain records of all storm water monitoring information and copies of all reports (including Annual Reports) for a period of at least three years. Risk Level 3 dischargers shall retain all records on-site while construction is ongoing. These records include:

- a. The date, place, time of facility inspections, sampling, visual observation (inspections), and/or measurements, including precipitation.
- b. The individual(s) who performed the facility inspections, sampling, visual observation (inspections), and or measurements.
- c. The date and approximate time of analyses.

⁷ For laboratory analysis, all sampling, sample preservation, and analyses must be conducted according to test procedures under 40 CFR Part 136. Field discharge samples shall be collected and analyzed according to the specifications of the manufacturer of the sampling devices employed.

- d. The individual(s) who performed the analyses.
- e. A summary of all analytical results from the last three years, the method detection limits and reporting units, the analytical techniques or methods used, and the chain of custody forms.
- f. Rain gauge readings from site inspections.
- g. Quality assurance/quality control records and results.
- h. Non-storm water discharge inspections and visual observation (inspections) and storm water discharge visual observation records (see Sections I.3 and I.10 above).
- i. Visual observation and sample collection exception records (see Section I.6 above).
- j. The records of any corrective actions and follow-up activities that resulted from analytical results, visual observation (inspections), or inspections.

15. Risk Level 3 – NAL Exceedance Report

- a. Risk Level 3 dischargers shall electronically submit all storm event sampling results to the State Water Board no later than 10 days after the conclusion of the storm event. The Regional Boards have the authority to require the submittal of an NAL Exceedance Report.
- b. Risk Level 3 dischargers shall certify each NAL Exceedance Report in accordance with the Special Provisions for Construction Activity In this General Permit.
- c. Risk Level 3 dischargers shall retain an electronic or paper copy of each NAL Exceedance Report for a minimum of three years after the date the annual report is filed.
- d. Risk Level 3 dischargers shall include in the NAL Exceedance Report:
 - i. The analytical method(s), method reporting unit(s), and method detection limit(s) of each analytical parameter (analytical results that are less than the method detection limit shall be reported as “less than the method detection limit”).

- ii. The date, place, time of sampling, visual observation (inspections), and/or measurements, including precipitation.
- iii. A description of the current BMPs associated with the effluent sample that exceeded the NAL and the proposed corrective actions taken.

16. Risk Level 3 – Bioassessment

- a. Risk Level 3 dischargers with a total project-related ground disturbance exceeding 30 acres shall:
 - i. Conduct bioassessment monitoring, as described in Appendix 3.
 - ii. Include the collection and reporting of specified in stream biological data and physical habitat.
 - iii. Use the bioassessment sample collection and Quality Assurance & Quality Control (QA/QC) protocols developed by the State of California's Surface Water Ambient Monitoring Program (SWAMP).⁸
- b. Risk Level 3 dischargers qualifying for bioassessment, where construction commences out of an index period for the site location shall:
 - i. Receive Regional Board approval for the sampling exception.
 - ii. Conduct bioassessment monitoring, as described in Appendix 3.
 - iii. Include the collection and reporting of specified instream biological data and physical habitat.
 - iv. Use the bioassessment sample collection and Quality Assurance & Quality Control (QA/QC) protocols developed by the State of California's Surface Water Ambient Monitoring Program (SWAMP).

OR

- v. Make a check payable to: Cal State Chico Foundation (SWAMP Bank Account) or San Jose State Foundation (SWAMP Bank Account) and include the WDID# on the check for the amount calculated for the exempted project.

⁸ http://www.waterboards.ca.gov/water_issues/programs/swamp/.

- vi. Send a copy of the check to the Regional Water Board office for the site's region.
- vii. Invest **\$7,500.00 X The number of samples required** into the SWAMP program as compensation (upon regional board approval).

Table 3 – Risk Level 3 Test Methods, Detection Limits, Reporting Units and Applicable NALs

Parameter	Test Method / Protocol	Discharge Type	Min. Detection Limit	Reporting Units	Numeric Action Level	Numeric Effluent Limitation	Receiving Water Monitoring Trigger
pH	Field test with calibrated portable instrument	Risk Level 3 Discharges	0.2	pH units	lower NAL = 6.5 upper NAL = 8.5	N/A	lower limit = 6.0 upper limit = 9.0
Turbidity	EPA 0180.1 and/or field test with calibrated portable instrument	Risk Level 3 Discharges other than ATS	1	NTU	250 NTU	N/A	500 NTU
		For ATS discharges	1	NTU	N/A	10 NTU for Daily Weighted Average & 20 NTU for Any Single Sample	10 NTU for Daily Weighted Average & 20 NTU for Any Single Sample
SSC	ASTM Method D 3977-97 ⁹	Risk Level 3 (if Receiving Water Monitoring Trigger exceeded)	5	mg/L	N/A	N/A	N/A
Bioassessment	(STE) Level I of (SAFIT), ¹⁰ fixed-count of 600 org/sample	Risk Level 3 projects > 30 acres	N/A	N/A	N/A	N/A	N/A

⁹ ASTM, 1999, Standard Test Method for Determining Sediment Concentration in Water Samples: American Society of Testing and Materials, D 3977-97, Vol. 11.02, pp. 389-394.

¹⁰ The current SAFIT STEs (28 November 2006) list requirements for both the Level I and Level II taxonomic effort, and are located at: http://www.swrcb.ca.gov/swamp/docs/safit/ste_list.pdf. When new editions are published by SAFIT, they will supersede all previous editions. All editions will be posted at the State Water Board's SWAMP website.

ATTACHMENT F: Active Treatment System (ATS) Requirements

Table 1 – Numeric Effluent Limitations, Numeric Action Levels, Test Methods, Detection Limits, and Reporting Units

Parameter	Test Method	Discharge Type	Min. Detection Limit	Units	Numeric Action Level	Numeric Effluent Limitation
Turbidity	EPA 0180.1 and/or field test with a calibrated portable instrument	For ATS discharges	1	NTU	N/A	10 NTU for Daily Flow-Weighted Average & 20 NTU for Any Single Sample

A. Dischargers choosing to implement an Active Treatment System (ATS) on their site shall comply with all of the requirements in this Attachment.

B. The discharger shall maintain a paper copy of each ATS specification onsite in compliance with the record retention requirements in the Special Provisions of this General Permit.

C. ATS Design, Operation and Submittals

1. The ATS shall be designed and approved by a Certified Professional in Erosion and Sediment Control (CPESC), a Certified Professional in Storm Water Quality (CPSWQ); a California registered civil engineer; or any other California registered engineer.
2. The discharger shall ensure that the ATS is designed in a manner to preclude the accidental discharge of settled floc¹ during floc pumping or related operations.
3. The discharger shall design outlets to dissipate energy from concentrated flows.
4. The discharger shall install and operate an ATS by assigning a lead person (or project manager) who has either a minimum of five years construction storm

¹ Floc is defined as a clump of solids formed by the chemical action in ATS systems.

water experience or who is a licensed contractors specifically holding a California Class A Contractors license.²

5. The discharger shall prepare an ATS Plan that combines the site-specific data and treatment system information required to safely and efficiently operate an ATS. The ATS Plan shall be electronically submitted to the State Water Board at least 14 days prior to the planned operation of the ATS and a paper copy shall be available onsite during ATS operation. At a minimum, the ATS Plan shall include:
 - a. ATS Operation and Maintenance Manual for All Equipment.
 - b. ATS Monitoring, Sampling & Reporting Plan, including Quality Assurance/Quality Control (QA/QC).
 - c. ATS Health and Safety Plan.
 - d. ATS Spill Prevention Plan.
6. The ATS shall be designed to capture and treat (within a 72-hour period) a volume equivalent to the runoff from a 10-year, 24-hour storm event using a watershed runoff coefficient of 1.0.

D. Treatment – Chemical Coagulation/Flocculation

1. Jar tests shall be conducted using water samples selected to represent typical site conditions and in accordance with ASTM D2035-08 (2003).
2. The discharger shall conduct, at minimum, six site-specific jar tests (per polymer with one test serving as a control) for each project to determine the proper polymer and dosage levels for their ATS.
3. Single field jar tests may also be conducted during a project if conditions warrant, for example if construction activities disturb changing types of soils, which consequently cause change in storm water and runoff characteristics.

E. Residual Chemical and Toxicity Requirements

1. The discharger shall utilize a residual chemical test method that has a method detection limit (MDL) of 10% or less than the maximum allowable threshold

² Business and Professions Code Division 3, Chapter 9, Article 4, Class A Contractor: A general engineering contractor is a contractor whose principal contracting business is in connection with fixed works requiring specialized engineering knowledge and skill. [<http://www.cslb.ca.gov/General-Information/library/licensing-classifications.asp>].

concentration³ (MATC) for the specific coagulant in use and for the most sensitive species of the chemical used.

2. The discharger shall utilize a residual chemical test method that produces a result within one hour of sampling.
3. The discharger shall have a California State certified laboratory validate the selected residual chemical test. Specifically the lab will review the test protocol, test parameters, and the detection limit of the coagulant. The discharger shall electronically submit this documentation as part of the ATS Plan.
4. If the discharger cannot utilize a residual chemical test method that meets the requirements above, the discharger shall operate the ATS in Batch Treatment⁴ mode.
5. A discharger planning to operate in Batch Treatment mode shall perform toxicity testing in accordance with the following:
 - a. The discharger shall initiate acute toxicity testing on effluent samples representing effluent from each batch prior to discharge⁵. All bioassays shall be sent to a laboratory certified by the Department of Health Services (DHS) Environmental Laboratory Accreditation Program (ELAP). The required field of testing number for Whole Effluent Toxicity (WET) testing is E113.⁶
 - b. Acute toxicity tests shall be conducted with the following species and protocols. The methods to be used in the acute toxicity testing shall be those outlined for a 96-hour acute test in "Methods for Measuring the Acute Toxicity of Effluents and Receiving Water to Freshwater and Marine Organisms, USEPA-841-R-02-012" for Fathead minnow, *Pimephales promelas* (fathead minnow). Acute toxicity for *Oncorhynchus mykiss* (Rainbow Trout) may be used as a substitute for testing fathead minnows.
 - c. All toxicity tests shall meet quality assurance criteria and test acceptability criteria in the most recent versions of the EPA test method for WET testing.
 - d. The discharger shall electronically report all acute toxicity testing.

³ The Maximum Allowable Threshold Concentration (MATC) is the allowable concentration of residual, or dissolved, coagulant/flocculant in effluent. The MATC shall be coagulant/flocculant-specific, and based on toxicity testing conducted by an independent, third-party laboratory. A typical MATC would be: The MATC is equal to the geometric mean of the NOEC (No Observed Effect Concentration) and LOEC (Lowest Observed Effect Concentration) Acute and Chronic toxicity results for most sensitive species determined for the specific coagulant. The most sensitive species test shall be used to determine the MATC.

⁴ Batch Treatment mode is defined as holding or recirculating the treated water in a holding basin or tank(s) until treatment is complete or the basin or storage tank(s) is full.

⁵ This requirement only requires that the test be initiated prior to discharge.

⁶ http://www.dhs.ca.gov/ps/ls/elap/pdf/FOT_Desc.pdf.

F. Filtration

1. The ATS shall include a filtration step between the coagulant treatment train and the effluent discharge. This is commonly provided by sand, bag, or cartridge filters, which are sized to capture suspended material that might pass through the clarifier tanks.
2. Differential pressure measurements shall be taken to monitor filter loading and confirm that the final filter stage is functioning properly.

G. Residuals Management

1. Sediment shall be removed from the storage or treatment cells as necessary to ensure that the cells maintain their required water storage (i.e., volume) capability.
2. Handling and disposal of all solids generated during ATS operations shall be done in accordance with all local, state, and federal laws and regulations.

H. ATS Instrumentation

1. The ATS shall be equipped with instrumentation that automatically measures and records effluent water quality data and flow rate.
2. The minimum data recorded shall be consistent with the Monitoring and Reporting requirements below, and shall include:
 - a. Influent Turbidity
 - b. Effluent Turbidity
 - c. Influent pH
 - d. Effluent pH
 - e. Residual Chemical
 - f. Effluent Flow rate
 - g. Effluent Flow volume
3. Systems shall be equipped with a data recording system, such as data loggers or webserver-based systems, which records each measurement on a frequency no longer than once every 15 minutes.

4. Cumulative flow volume shall be recorded daily. The data recording system shall have the capacity to record a minimum of seven days continuous data.
5. Instrumentation systems shall be interfaced with system control to provide auto shutoff or recirculation in the event that effluent measurements exceed turbidity or pH.
6. The system shall also assure that upon system upset, power failure, or other catastrophic event, the ATS will default to a recirculation mode or safe shut down.
7. Instrumentation (flow meters, probes, valves, streaming current detectors, controlling computers, etc.) shall be installed and maintained per manufacturer's recommendations, which shall be included in the QA/QC plan.
8. The QA/QC plan shall also specify calibration procedures and frequencies, instrument method detection limit or sensitivity verification, laboratory duplicate procedures, and other pertinent procedures.
9. The instrumentation system shall include a method for controlling coagulant dose, to prevent potential overdosing. Available technologies include flow/turbidity proportional metering, periodic jar testing and metering pump adjustment, and ionic charge measurement controlling the metering pump.

I. ATS Effluent Discharge

1. ATS effluent shall comply with all provisions and prohibitions in this General Permit, specifically the NELs.
2. NELs for discharges from an ATS:
 - a. Turbidity of all ATS discharges shall be less than 10 NTU for daily flow-weighted average of all samples and 20 NTU for any single sample.
 - b. Residual Chemical shall be < 10% of MATC⁷ for the most sensitive species of the chemical used.

⁷ The Maximum Allowable Threshold Concentration (MATC) is the allowable concentration of residual, or dissolved, coagulant/flocculant in effluent. The MATC shall be coagulant/flocculant-specific, and based on toxicity testing conducted by an independent, third-party laboratory. The MATC is equal to the geometric mean of the NOEC (No Observed Effect Concentration) and LOEC (Lowest Observed Effect Concentration) Acute and Chronic toxicity results for most sensitive species determined for the specific coagulant. The most sensitive species test shall be used to determine the MATC.

3. If an analytical effluent sampling result exceeds the turbidity NEL (as listed in Table 1), the discharger is in violation of this General Permit and shall electronically file the results in violation within 24-hours of obtaining the results.
4. If ATS effluent is authorized to discharge into a sanitary sewer system, the discharger shall comply with any pre-treatment requirements applicable for that system. The discharger shall include any specific criteria required by the municipality in the ATS Plan.
5. Compliance Storm Event:

Discharges of storm water from ATS shall comply with applicable NELs (above) unless the storm event causing the discharges is determined after the fact to be equal to or larger than the Compliance Storm Event (expressed in inches of rainfall). The Compliance Storm Event for ATS discharges is the 10 year, 24 hour storm, as determined using these maps:

<http://www.wrcc.dri.edu/pcpnfreq/nca10y24.gif>
<http://www.wrcc.dri.edu/pcpnfreq/sca10y24.gif>

This exemption is dependent on the submission of rain gauge data verifying the storm event is equal to or larger than the Compliance Storm.

J. Operation and Maintenance Plan

1. Each Project shall have a site-specific Operation and Maintenance (O&M) Manual covering the procedures required to install, operate and maintain the ATS.⁸
2. The O&M Manual shall only be used in conjunction with appropriate project-specific design specifications that describe the system configuration and operating parameters.
3. The O&M Manual shall have operating manuals for specific pumps, generators, control systems, and other equipment.

K. Sampling and Reporting Quality Assurance/ Quality Check (QA/QC) Plan

4. A project-specific QA/QC Plan shall be developed for each project. The QA/QC Plan shall include at a minimum:
 - a. Calibration – Calibration methods and frequencies for all system and field instruments shall be specified.

⁸ The manual is typically in a modular format covering generalized procedures for each component that is utilized in a particular system.

- b. Method Detection Limits (MDLs) – The methods for determining MDLs shall be specified for each residual coagulant measurement method. Acceptable minimum MDLs for each method, specific to individual coagulants, shall be specified.
- c. Laboratory Duplicates – Requirements for monthly laboratory duplicates for residual coagulant analysis shall be specified.

L. Personnel Training

- 1. Operators shall have training specific to using an ATS and liquid coagulants for storm water discharges in California.
- 2. The training shall be in the form of a formal class with a certificate and requirements for testing and certificate renewal.
- 3. Training shall include a minimum of eight hours classroom and 32 hours field training. The course shall cover the following topics:
 - a. Coagulation Basics –Chemistry and physical processes
 - b. ATS System Design and Operating Principles
 - c. ATS Control Systems
 - d. Coagulant Selection – Jar testing, dose determination, etc.
 - e. Aquatic Safety/Toxicity of Coagulants, proper handling and safety
 - f. Monitoring, Sampling, and Analysis
 - g. Reporting and Recordkeeping
 - h. Emergency Response

M. Active Treatment System (ATS) Monitoring Requirements

Any discharger who deploys an ATS on their site shall conduct the following:

- 1. Visual Monitoring
 - a. A designated responsible person shall be on site daily at all times during treatment operations.

- b. Daily on-site visual monitoring of the system for proper performance shall be conducted and recorded in the project data log.
 - i. The log shall include the name and phone number of the person responsible for system operation and monitoring.
 - ii. The log shall include documentation of the responsible person's training.

2. Operational and Compliance Monitoring

- a. Flow shall be continuously monitored and recorded at not greater than 15-minute intervals for total volume treated and discharged.
- b. Influent and effluent pH must be continuously monitored and recorded at not greater than 15-minute intervals.
- c. Influent and effluent turbidity (expressed in NTU) must be continuously monitored and recorded at not greater than 15-minute intervals.
- d. The type and amount of chemical used for pH adjustment, if any, shall be monitored and recorded.
- e. Dose rate of chemical used in the ATS system (expressed in mg/L) shall be monitored and reported 15-minutes after startup and every 8 hours of operation.
- f. Laboratory duplicates – monthly laboratory duplicates for residual coagulant analysis must be performed and records shall be maintained onsite.
- g. Effluent shall be monitored and recorded for residual chemical/additive levels.
- h. If a residual chemical/additive test does not exist and the ATS is operating in a batch treatment mode of operation refer to the toxicity monitoring requirements below.

3. Toxicity Monitoring

A discharger operating in batch treatment mode shall perform toxicity testing in accordance with the following:

- a. The discharger shall initiate acute toxicity testing on effluent samples representing effluent from each batch prior to discharge.⁹ All bioassays shall be sent to a laboratory certified by the Department of Health Services (DHS)

⁹ This requirement only requires that the test be initiated prior to discharge.

Environmental Laboratory Accreditation Program (ELAP). The required field of testing number for Whole Effluent Toxicity (WET) testing is E113.¹⁰

- b. Acute toxicity tests shall be conducted with the following species and protocols. The methods to be used in the acute toxicity testing shall be those outlined for a 96-hour acute test in “Methods for Measuring the Acute Toxicity of Effluents and Receiving Water to Freshwater and Marine Organisms, USEPA-841-R-02-012” for Fathead minnow, *Pimephales promelas* or Rainbow trout *Oncorhynchus mykiss* may be used as a substitute for fathead minnow.
- c. All toxicity tests shall meet quality assurance criteria and test acceptability criteria in the most recent versions of the EPA test method for WET testing.¹¹

4. Reporting and Recordkeeping

At a minimum, every 30 days a LRP representing the discharger shall access the State Water Boards Storm Water Multi-Application and Report Tracking system (SMARTS) and electronically upload field data from the ATS. Records must be kept for three years after the project is completed .

5. Non-compliance Reporting

- a. Any indications of toxicity or other violations of water quality objectives shall be reported to the appropriate regulatory agency as required by this General Permit.
- b. Upon any measurements that exceed water quality standards, the system operator shall immediately notify his supervisor or other responsible parties, who shall notify the Regional Water Board.
- c. If any monitoring data exceeds any applicable NEL in this General Permit, the discharger shall electronically submit a NEL Violation Report to the State Water Board within 24 hours after the NEL exceedance has been identified.
 - i. ATS dischargers shall certify each NEL Violation Report in accordance with the Special Provisions for Construction Activity in this General Permit.
 - ii. ATS dischargers shall retain an electronic or paper copy of each NEL Violation Report for a minimum of three years after the date the annual report is filed.
 - iii. ATS dischargers shall include in the NEL Violation Report:

¹⁰ http://www.dhs.ca.gov/ps/ls/elap/pdf/FOT_Desc.pdf.

¹¹ <http://www.epa.gov/waterscience/methods/wet/>.

- (1) The analytical method(s), method reporting unit(s), and method detection limit(s) of each analytical parameter (analytical results that are less than the method detection limit shall be reported as “less than the method detection limit”);
 - (2) The date, place, time of sampling, visual observation (inspections), and/or measurements, including precipitation; and
 - (3) A description of the current onsite BMPs, and the proposed corrective actions taken to manage the NEL exceedance.
- iv. Compliance Storm Exemption - In the event that an applicable NEL has been exceeded during a storm event equal to or larger than the Compliance Storm Event, ATS dischargers shall report the on-site rain gauge reading and nearby governmental rain gauge readings for verification.

	A	B	C
1	Sediment Risk Factor Worksheet		Entry
2	A) R Factor		
3	Analyses of data indicated that when factors other than rainfall are held constant, soil loss is directly proportional to a rainfall factor composed of total storm kinetic energy (E) times the maximum 30-min intensity (I30) (Wischmeier and Smith, 1958). The numerical value of R is the average annual sum of EI30 for storm events during a rainfall record of at least 22 years. "Isoerodent" maps were developed based on R values calculated for more than 1000 locations in the Western U.S. Refer to the link below to determine the R factor for the project site.		
4	http://cfpub.epa.gov/npdes/stormwater/LEW/lewCalculator.cfm		
5		R Factor Value	0
6	B) K Factor (weighted average, by area, for all site soils)		
7	The soil-erodibility factor K represents: (1) susceptibility of soil or surface material to erosion, (2) transportability of the sediment, and (3) the amount and rate of runoff given a particular rainfall input, as measured under a standard condition. Fine-textured soils that are high in clay have low K values (about 0.05 to 0.15) because the particles are resistant to detachment. Coarse-textured soils, such as sandy soils, also have low K values (about 0.05 to 0.2) because of high infiltration resulting in low runoff even though these particles are easily detached. Medium-textured soils, such as a silt loam, have moderate K values (about 0.25 to 0.45) because they are moderately susceptible to particle detachment and they produce runoff at moderate rates. Soils having a high silt content are especially susceptible to erosion and have high K values, which can exceed 0.45 and can be as large as 0.65. Silt-size particles are easily detached and tend to crust, producing high rates and large volumes of runoff. Use Site-specific data must be submitted.		
8	Site-specific K factor guidance		
9		K Factor Value	0
10	C) LS Factor (weighted average, by area, for all slopes)		
11	The effect of topography on erosion is accounted for by the LS factor, which combines the effects of a hillslope-length factor, L, and a hillslope-gradient factor, S. Generally speaking, as hillslope length and/or hillslope gradient increase, soil loss increases. As hillslope length increases, total soil loss and soil loss per unit area increase due to the progressive accumulation of runoff in the downslope direction. As the hillslope gradient increases, the velocity and erosivity of runoff increases. Use the LS table located in separate tab of this spreadsheet to determine LS factors. Estimate the weighted LS for the site prior to construction.		
12	LS Table		
13		LS Factor Value	0
14			
15	Watershed Erosion Estimate (=R_xK_xLS) in tons/acre		0
16	Site Sediment Risk Factor		Low
17	Low Sediment Risk: < 15 tons/acre		
18	Medium Sediment Risk: >=15 and <75 tons/acre		
19	High Sediment Risk: >= 75 tons/acre		
20			
21			
22			
23	GIS Map Method:		
24	1. The R factor for the project is calculated using the online calculator at:		
25	http://cfpub.epa.gov/npdes/stormwater/LEW/lewCalculator.cfm		
26			
27	2. The K and LS factors may be obtained by accessing the GIS maps located on the State Water Board FTP website at:		
28	ftp://swrcb2a.waterboards.ca.gov/pub/swrcb/dwq/cgp/Risk/		
29			

Receiving Water (RW) Risk Factor Worksheet	Entry	Score
A. Watershed Characteristics	yes/no	
A.1. Does the disturbed area discharge (either directly or indirectly) to a 303(d)-listed waterbody impaired by sediment (For help with impaired waterbodies please visit the link below) or has a USEPA approved TMDL implementation plan for sediment ? http://www.waterboards.ca.gov/water_issues/programs/tmdl/integrated2010.shtml	no	Low
OR		
A.2. Does the disturbed area discharge to a waterbody with designated beneficial uses of SPAWN & COLD & MIGRATORY? (For help please review the appropriate Regional Board Basin Plan) http://www.waterboards.ca.gov/waterboards_map.shtml		
Region 1 Basin Plan Region 2 Basin Plan Region 3 Basin Plan Region 4 Basin Plan Region 5 Basin Plan Region 6 Basin Plan Region 7 Basin Plan Region 8 Basin Plan Region 9 Basin Plan		

Combined Risk Level Matrix

		<u>Sediment Risk</u>		
		Low	Medium	High
<u>Receiving Water Risk</u>	Low	Level 1	Level 2	
	High	Level 2		Level 3

Project Sediment Risk: **Low**

Project RW Risk: **Low**

Project Combined Risk: **Level 1**

Soil Erodibility Factor (K)

The K factor can be determined by using the nomograph method, which requires that a particle size analysis (ASTM D-422) be done to determine the percentages of sand, very fine sand, silt and clay. Use the figure below to determine appropriate K value.

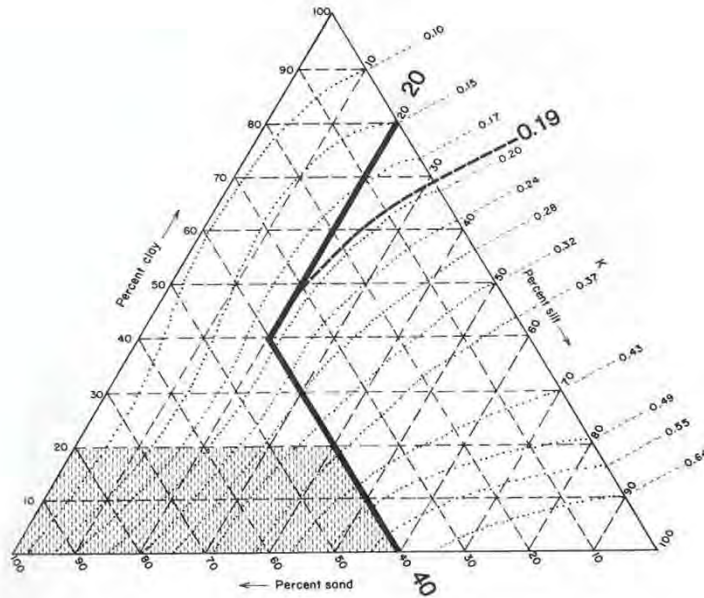

Erickson triangular nomograph used to estimate soil erodibility (K) factor.

The figure above is the USDA nomograph used to determine the K factor for a soil, based on its texture (% silt plus very fine sand, % sand, % organic matter, soil structure, and permeability). *Nomograph from Erickson 1977 as referenced in Goldman et. al., 1986.*

		Average Watershed Slope (%)																	
Sheet Flow Length (ft)																			
	0.2	0.5	1.0	2.0	3.0	4.0	5.0	6.0	8.0	10.0	12.0	14.0	16.0	20.0	25.0	30.0	40.0	50.0	60.0
<3	0.05	0.07	0.09	0.13	0.17	0.20	0.23	0.26	0.32	0.35	0.36	0.38	0.39	0.41	0.45	0.48	0.53	0.58	0.63
6	0.05	0.07	0.09	0.13	0.17	0.20	0.23	0.26	0.32	0.37	0.41	0.45	0.49	0.56	0.64	0.72	0.85	0.97	1.07
9	0.05	0.07	0.09	0.13	0.17	0.20	0.23	0.26	0.32	0.38	0.45	0.51	0.56	0.67	0.80	0.91	1.13	1.31	1.47
12	0.05	0.07	0.09	0.13	0.17	0.20	0.23	0.26	0.32	0.39	0.47	0.55	0.62	0.76	0.93	1.08	1.37	1.62	1.84
15	0.05	0.07	0.09	0.13	0.17	0.20	0.23	0.26	0.32	0.40	0.49	0.58	0.67	0.84	1.04	1.24	1.59	1.91	2.19
25	0.05	0.07	0.10	0.16	0.21	0.26	0.31	0.36	0.45	0.57	0.71	0.85	0.98	1.24	1.56	1.86	2.41	2.91	3.36
50	0.05	0.08	0.13	0.21	0.30	0.38	0.46	0.54	0.70	0.91	1.15	1.40	1.64	2.10	2.67	3.22	4.24	5.16	5.97
75	0.05	0.08	0.14	0.25	0.36	0.47	0.58	0.69	0.91	1.20	1.54	1.87	2.21	2.86	3.67	4.44	5.89	7.20	8.37
100	0.05	0.09	0.15	0.28	0.41	0.55	0.68	0.82	1.10	1.46	1.88	2.31	2.73	3.57	4.59	5.58	7.44	9.13	10.63
150	0.05	0.09	0.17	0.33	0.50	0.68	0.86	1.05	1.43	1.92	2.51	3.09	3.68	4.85	6.30	7.70	10.35	12.75	14.89
200	0.06	0.10	0.18	0.37	0.57	0.79	1.02	1.25	1.72	2.34	3.07	3.81	4.56	6.04	7.88	9.67	13.07	16.16	18.92
250	0.06	0.10	0.19	0.40	0.64	0.89	1.16	1.43	1.99	2.72	3.60	4.48	5.37	7.16	9.38	11.55	15.67	19.42	22.78
300	0.06	0.10	0.20	0.43	0.69	0.98	1.28	1.60	2.24	3.09	4.09	5.11	6.15	8.23	10.81	13.35	18.17	22.57	26.51
400	0.06	0.11	0.22	0.48	0.80	1.14	1.51	1.90	2.70	3.75	5.01	6.30	7.60	10.24	13.53	16.77	22.95	28.60	33.67
600	0.06	0.12	0.24	0.56	0.96	1.42	1.91	2.43	3.52	4.95	6.67	8.45	10.26	13.94	18.57	23.14	31.89	39.95	47.18
800	0.06	0.12	0.26	0.63	1.10	1.65	2.25	2.89	4.24	6.03	8.17	10.40	12.69	17.35	23.24	29.07	40.29	50.63	59.93
1000	0.06	0.13	0.27	0.69	1.23	1.86	2.55	3.30	4.91	7.02	9.57	12.23	14.96	20.57	27.66	34.71	48.29	60.84	72.15

LS Factors for Construction Sites. *Table from Renard et. al., 1997.*

APPENDIX 2: Post-Construction Water Balance Performance Standard Spreadsheet

The discharger shall submit with their Notice of Intent (NOI) the following information to demonstrate compliance with the New and Re-Development Water Balance Performance Standard.

Map Instructions

The discharger must submit a small-scale topographic map of the site to show the existing contour elevations, pre- and post-construction drainage divides, and the total length of stream in each watershed area. Recommended scales include 1 in. = 20 ft., 1 in. = 30 ft., 1 in. = 40 ft., or 1 in. = 50 ft. The suggested contour interval is usually 1 to 5 feet, depending upon the slope of the terrain. The contour interval may be increased on steep slopes. Other contour intervals and scales may be appropriate given the magnitude of land disturbance.

Spreadsheet Instructions

The intent of the spreadsheet is to help dischargers calculate the project-related increase in runoff volume and select impervious area and runoff reduction credits to reduce the project-related increase in runoff volume to pre-project levels.

The discharger has the option of using the spreadsheet (**Appendix 2.1**) or a more sophisticated, watershed process-based model (e.g. Storm Water Management Model, Hydrological Simulation Program Fortran) to determine the project-related increase in runoff volume.

In Appendix 4.1, you must complete the worksheet for each land use/soil type combination for each project sub-watershed.

Steps 1 through 9 pertain specifically to the Runoff Volume Calculator:

Step 1: Enter the county where the project is located in cell H3.

Step 2: Enter the soil type in cell H6.

Step 3: Enter the existing pervious (dominant) land use type in cell H7.

Step 4: Enter the proposed pervious (dominant) land use type in cell H8.

Step 5: Enter the total project site area in cell H11 or J11.

Step 6: Enter the sub-watershed area in cell H12 or J12.

- Step 7: Enter the existing rooftop area in cell H17 or J17, the existing non-rooftop impervious area in cell H18 or J18, the proposed rooftop area in cell H19 or J19, and the proposed non-rooftop impervious area in cell H20 or J20
- Step 8: Work through each of the impervious area reduction credits and claim credits where applicable. Volume that cannot be addressed using non-structural practices must be captured in structural practices and approved by the Regional Water Board.
- Step 9: Work through each of the impervious volume reduction credits and claim credits where applicable. Volume that cannot be addressed using non-structural practices must be captured in structural practices and approved by the Regional Water Board.

Non-structural Practices Available for Crediting

- ***Porous Pavement***
- ***Tree Planting***
- ***Downspout Disconnection***
- ***Impervious Area Disconnection***
- ***Green Roof***
- ***Stream Buffer***
- ***Vegetated Swales***
- ***Rain Barrels and Cisterns***
- ***Landscaping Soil Quality***

Post-Construction Water Balance Calculator

1	Post-Construction Water Balance Calculator													
2														
3	User may make changes from any cell that is orange or brown in color (similar to the cells to the immediate right). Cells in green are calculated for you.		(Step 1a) If you know the 85th percentile storm event for your location enter it in the box below		(Step 1b) If you can not answer 1a then select the county where the project is located (click on the cell to the right for drop-down): This will determine the average 85th percentile 24 hr. storm event for your site, which will appear under precipitation to left.		SACRAMENTO							
4			(Step 1c) If you would like a more precise value select the location closest to your site. If you do not recognize any of these locations, leave this drop-down menu at location. The average value for the County will be used.		SACRAMENTO FAA ARPT									
5	Project Information				Runoff Calculations									
6	Project Name:		Optional		(Step 2) Indicate the Soil Type (dropdown menu to right):		Group C Soils		Low infiltration. Sandy clay loam. Infiltration rate 0.05 to 0.15 inch/hr when wet.					
7	Waste Discharge Identification (WDID):		Optional		(Step 3) Indicate the existing dominant non-built land Use Type (dropdown menu to right):		Wood & Grass: <50% ground cover							
8	Date:		Optional		(Step 4) Indicate the proposed dominant non-built land Use Type (dropdown menu to right):		Lawn, Grass, or Pasture covering more than 75% of the open space							
9	Sub Drainage Area Name (from map):		Optional				Complete Either							
10	Runoff Curve Numbers						Sq Ft		Acres					
11	Existing Pervious Runoff Curve Number		82		(Step 5) Total Project Site Area:		5.00		5.00					
12	Proposed Development Pervious Runoff Curve Number		74		(Step 6) Sub-watershed Area:		5.00		5.00					
13	Design Storm				Percent of total project :		100%							
14	Based on the County you indicated above, we have included the 85 percentile average 24 hr event - P85 (in)^* for your area.		0.62		in									
15	The Amount of rainfall needed for runoff to occur (Existing runoff curve number -P from existing RCN (in)^*)		0.44		in		(Step 7) Sub-watershed Conditions		Complete Either					
16	P used for calculations (in) (the greater of the above two criteria)		0.62		in		Sub-watershed Area (acres)		Calculated Acres					
17	*Available at www.cabmphandbooks.com				Existing Rooftop Impervious Coverage		0		0.00					
18					Existing Non-Rooftop Impervious Coverage		0		0.00					
19					Proposed Rooftop Impervious Coverage		0		0.00					
20					Proposed Non-Rooftop Impervious Coverage		0		0.00					
21					Credits		Acres		Square Feet					
22					Porous Pavement		0.00		0					
23					Tree Planting		0.00		0					
24														
25	Pre-Project Runoff Volume (cu ft)		247		Cu.Ft.		Downspout Disconnection		0.00					
26	Project-Related Runoff Volume Increase w/o credits (cu ft)		0		Cu.Ft.		Impervious Area Disconnection		0.00					
27							Green Roof		0.00					
28							Stream Buffer		0.00					
29							Vegetated Swales		0.00					
30	Project-Related Volume Increase with Credits (cu ft)		0		Cu.Ft.		Subtotal		0.00					
31							Subtotal Runoff Volume Reduction Credit		0 Cu. Ft.					
32	You have achieved your minimum requirements						(Step 9) Impervious Volume Reduction Credits		Volume (cubic feet)					
33									Rain Barrels/Cisterns		0 Cu. Ft.			
34									Soil Quality		0 Cu. Ft.			
35											Subtotal Runoff Volume Reduction		0 Cu. Ft.	
36											Total Runoff Volume Reduction Credit		0 Cu. Ft.	
37														
38														
39														

Porous Pavement Credit Worksheet

Please fill out a porous pavement credit worksheet for each project sub-watershed.

For the PROPOSED Development:

Proposed Porous Pavement	Runoff Reduction*	Fill in either Acres or SqFt		Equivalent Acres
		In SqFt.	In Acres	
Area of Brick without Grout on <u>less than 12 inches</u> of base with at least 20% void space over soil	0.45			0.00
Area of Brick without Grout on <u>more than 12 inches</u> of base with at least 20% void space over soil	0.90			0.00
Area of Cobbles <u>less than 12 inches</u> deep and over soil	0.30			0.00
Area of Cobbles <u>less than 12 inches</u> deep and over soil	0.60			0.00
Area of Reinforced Grass Pavement on <u>less than 12 inches</u> of base with at least 20% void space over soil	0.45			0.00
Area of Reinforced Grass Pavement on <u>at least 12 inches</u> of base with at least 20% void space over soil	0.90			0.00
Area of Porous Gravel Pavement on <u>less than 12 inches</u> of base with at least 20% void space over soil	0.38			0.00
Area of Porous Gravel Pavement on <u>at least 12 inches</u> of base with at least 20% void space over soil	0.75			0.00
Area of Poured Porous Concrete or Asphalt Pavement with <u>less than 4 inches</u> of gravel base (washed stone)	0.40			0.00
Area of Poured Porous Concrete or Asphalt Pavement with <u>4 to 8 inches</u> of gravel base (washed stone)	0.60			0.00
Area of Poured Porous Concrete or Asphalt Pavement with <u>8 to 12 inches</u> of gravel base (washed stone)	0.80			0.00
Area of Poured Porous Concrete or Asphalt Pavement with <u>12 or more</u> inches of gravel base (washed stone)	1.00			0.00

*=1-Rv**

[Return to Calculator](#)

**Using Site Design Techniques to meet Development Standards for Stormwater Quality (BASMAA 2003)

**NCDENR Stormwater BMP Manual (2007)

Tree Planting Credit Worksheet

Please fill out a tree canopy credit worksheet for each project sub-watershed.

Tree Canopy Credit Criteria	Number of Trees Planted	Credit (acres)
Number of proposed evergreen trees to be planted (credit = number of trees x 0.005)*	0	0.00
Number of proposed deciduous trees to be planted (credit = number of trees x 0.0025)*		0.00
	Square feet Under Canopy	
Square feet under an existing tree canopy, that will remain on the property, with an average diameter at 4.5 ft above grade (i.e., diameter at breast height or DBH) is LESS than 12 in diameter.		0.00
Square feet under an existing tree canopy that will remain on the property, with an average diameter at 4.5 ft above grade (i.e., diameter at breast height or DBH) is 12 in diameter or GREATER.		0.00
Please describe below how the project will ensure that these trees will be maintained.		

0

[Return to Calculator](#)

* credit amount based on credits from Stormwater Quality Design Manual for the Sacramento and South Placer Regions

Downspout Disconnection Credit Worksheet

Please fill out a downspout disconnection credit worksheet for each project subwatershed. If you answer yes to all questions, all rooftop area draining to each downspout will be subtracted from your proposed rooftop impervious coverage.

Downspout Disconnection Credit Criteria					
Do downspouts and any extensions extend at least six feet from a basement and two feet from a crawl space or concrete slab?				<input type="radio"/> Yes	<input checked="" type="radio"/> No
Is the area of rooftop connecting to each disconnected downspout 600 square feet or less?				<input type="radio"/> Yes	<input checked="" type="radio"/> No
Is the roof runoff from the design storm event fully contained in a raised bed or planter box or does it drain as sheet flow to a landscaped area large enough to contain the roof runoff from the design storm event?				<input type="radio"/> Yes	<input checked="" type="radio"/> No
The Stream Buffer and/or Vegetated Swale credits will not be taken in this sub-watershed area?				<input type="radio"/> Yes	<input checked="" type="radio"/> No
Percentage of existing	0.00	Acres	of rooftop surface has disconnected downspouts		
Percentage of the proposed	0.00	Acres	of rooftop surface has disconnected downspouts		
				Return to Calculator	

Impervious Area Disconnection Credit Worksheet

Please fill out an impervious area disconnection credit worksheet for each project sub-watershed. If you answer yes to all questions, all non-rooftop impervious surface area will be subtracted from your proposed non-rooftop impervious coverage.

Non-Rooftop Disconnection Credit Criteria	Response
Is the maximum contributing impervious flow path length less than 75 feet or, if equal or greater than 75 feet, is a storage device (e.g. French drain, bioretention area, gravel trench) implemented to achieve the required disconnection length?	<input checked="" type="radio"/> Yes <input type="radio"/> No
Is the impervious area to any one discharge location less than 5,000 square feet?	<input checked="" type="radio"/> Yes <input type="radio"/> No
The Stream Buffer credit will not be taken in this sub-watershed area?	<input checked="" type="radio"/> Yes <input type="radio"/> No

Percentage of existing	0.00	Acres non-rooftop surface area disconnected	
Percentage of the proposed	0.00	Acres non-rooftop surface area disconnected	70

[Return to Calculator](#)

Green Roof Credit Worksheet

Please fill out a greenroof credit worksheet for each project sub-watershed. If you answer yes to all questions, 70% of the greenroof area will be subtracted from your proposed rooftop impervious coverage.

Green Roof Credit Criteria		Response
Is the roof slope less than 15% or does it have a grid to hold the substrate in place until it forms a thick vegetation mat?	<input checked="" type="radio"/> Yes <input type="radio"/> No	
Has a professional engineer assessed the necessary load reserves and designed a roof structure to meet state and local codes?	<input checked="" type="radio"/> Yes <input type="radio"/> No	
Is the irrigation needed for plant establishment and/or to sustain the green roof during extended dry periods, is the source from stored, recycled, reclaimed, or reused water?	<input checked="" type="radio"/> Yes <input type="radio"/> No	
Percentage of existing 0.0 0 Acres rooftop surface area in greenroof		
Percentage of the proposed 0.0 0 Acres rooftop surface area in greenroof		
Return to Calculator		

Stream Buffer Credit Worksheet

Please fill out a stream buffer credit worksheet for each project sub-watershed. If you answer yes to all questions, you may subtract all impervious surface draining to each stream buffer that has not been addressed using the Downspout and/or Impervious Area Disconnection credits.

Stream Buffer Credit Criteria				Response
Does runoff enter the floodprone width* or within 500 feet (whichever is larger) of a stream channel as sheet flow**?				<input type="radio"/> Yes <input checked="" type="radio"/> No
Is the contributing overland slope 5% or less, or if greater than 5%, is a level spreader used?				<input type="radio"/> Yes <input checked="" type="radio"/> No
Is the buffer area protected from vehicle or other traffic barriers to reduce compaction?				<input type="radio"/> Yes <input checked="" type="radio"/> No
Will the stream buffer be maintained in an ungraded and uncompacted condition and will the vegetation be maintained in a natural condition?				<input type="radio"/> Yes <input checked="" type="radio"/> No
Percentage of existing	0.00	Acres	impervious surface area draining into a stream buffer:	
Percentage of the proposed	0.00	Acres	impervious surface area that will drain into a stream buffer:	
Please describe below how the project will ensure that the buffer areas will remain in ungraded and uncompacted condition and that the vegetation will be maintained in a natural condition.				

[Return to Calculator](#)

* floodprone width is the width at twice the bankfull depth.

** the maximum contributing length shall be 75 feet for impervious area

Vegetated Swale Credit Worksheet

Please fill out a vegetated swale worksheet for each project subwatershed. If you answer yes to all questions, you may subtract all impervious surface draining to each stream buffer that has not been addressed using the Downspout Disconnection credit.

Vegetated Swale Credit Criteria

Have all vegetated swales been designed in accordance with Treatment Control BMP 30 (TC-30 - Vegetated Swale) from the California Stormwater BMP Handbook, New Development and Redevelopment (available at www.cabmphandbooks.com)?

<input type="radio"/> Yes	<input checked="" type="radio"/> No
---------------------------	-------------------------------------

Is the maximum flow velocity for runoff from the design storm event less than or equal to 1.0 foot per second?

<input type="radio"/> Yes	<input checked="" type="radio"/> No
---------------------------	-------------------------------------

Percentage of existing	0.00	Acres of impervious area draining to a vegetated swale	
Percentage of the proposed	0.00	Acres of impervious area draining to a vegetated swale	

[Return to Calculator](#)

Rain Barrel/Cistern Credit Worksheet

Please fill out a rain barrel/cistern worksheet for each project sub-watershed.

Rain Barrel/Cistern Credit Criteria	Response
Total number of rain barrel(s)/cisterns	
Average capacity of rain barrel(s)/cistern(s) (in gallons)	
Total capacity rain barrel(s)/cistern(s) (in cu ft) ¹	0

¹ accounts for 10% loss

[Return to Calculator](#)

Please fill out a soil quality worksheet for each project sub-watershed.

	Response
Will the landscaped area be lined with an impervious membrane?	
Will the soils used for landscaping meet the ideal bulk densities listed in Table 1 below? ¹	<input type="radio"/> Yes <input checked="" type="radio"/> No
If you answered yes to the question above, and you know the area-weighted bulk density within the top 12 inches for soils used for landscaping (in g/cm ³)*, fill in the cell to the right and skip to cell G11. If not select from the drop-down menu in G10.	1.3
If you answered yes to the question above, but you do not know the exact bulk density, which of the soil types in the drop down menu to the right best describes the top 12 inches for soils used for landscaping (in g/cm ³).	Sandy loams, loams
What is the average depth of your landscaped soil media meeting the above criteria (inches)?	12
What is the total area of the landscaped areas meeting the above criteria (in acres)?	2.97

[Return to Calculator](#)

Table 1

Sands, loamy sands	<1.6
Sandy loams, loams	<1.4
Sandy clay loams, loams, clay loams	<1.4
Silts, silt loams	<1.3
Silt loams, silty clay loams	<1.1
Sandy clays, silty clays, some clay loams (35-45% clay)	<1.1
Clays (>45% clay)	<1.1

Porosity (%) 50.94%

Mineral grains in many soils are mainly quartz and feldspar, so 2.65 a good average for particle density. To determine percent porosity, use the formula: Porosity (%) = (1-Bulk Density/2.65) X 100

¹ USDA NRCS. "Soil Quality Urban Technical Note No.2-Urban Soil Compaction". March 2000.

http://soils.usda.gov/sqi/management/files/sq_utn_2.pdf

* To determine how to calculate density see:

<http://www.globe.gov/tctg/bulkden.pdf?sectionID=94>

APPENDIX 3 Bioassessment Monitoring Guidelines

Bioassessment monitoring is required for projects that meet all of the following criteria:

1. The project is rated Risk Level 3 or LUP Type 3
2. The project directly discharges runoff to a freshwater wadeable stream (or streams) that is either: (a) listed by the State Water Board or USEPA as impaired due to sediment, and/or (b) tributary to any downstream water body that is listed for sediment; and/or have the beneficial use SPAWN & COLD & MIGRATORY
3. Total project-related ground disturbance exceeds 30 acres.

For all such projects, the discharger shall conduct bioassessment monitoring, as described in this section, to assess the effect of the project on the biological integrity of receiving waters.

Bioassessment shall include:

1. The collection and reporting of specified instream biological data
2. The collection and reporting of specified instream physical habitat data

Bioassessment Exception

If a site qualifies for bioassessment, but construction commences out of an index period for the site location, the discharger shall:

1. Receive Regional Water Board approval for the sampling exception
2. Make a check payable to: Cal State Chico Foundation (SWAMP Bank Account) or San Jose State Foundation (SWAMP Bank Account) and include the WDID# on the check for the amount calculated for the exempted project.
3. Send a copy of the check to the Regional Water Board office for the site's region
4. Invest **7,500.00 X The number of samples required** into the SWAMP program as compensation (upon Regional Water Board approval).
5. Conduct bioassessment monitoring, as described in Appendix 4
6. Include the collection and reporting of specified instream biological data and physical habitat
7. Use the bioassessment sample collection and Quality Assurance & Quality Control (QA/QC) protocols developed by the State of California's Surface Water Ambient Monitoring Program (SWAMP)

Site Locations and Frequency

Macroinvertebrate samples shall be collected both before ground disturbance is initiated and after the project is completed. The "after" sample(s) shall be collected after at least one winter season resulting in surface runoff has transpired after project-related ground disturbance has ceased. "Before" and "after" samples shall be collected both upstream and downstream of the project's

discharge. Upstream samples should be taken immediately before the sites outfall and downstream samples should be taken immediately after the outfall (when safe to collect the samples). Samples should be collected for each freshwater wadeable stream that is listed as impaired due to sediment, or tributary to a water body that is listed for sediment. Habitat assessment data shall be collected concurrently with all required macroinvertebrate samples.

Index Period (Timing of Sample Collection)

Macroinvertebrate sampling shall be conducted during the time of year (i.e., the “index period”) most appropriate for bioassessment sampling, depending on ecoregion. This map is posted on the State Water Board’s Website: http://www.waterboards.ca.gov/water_issues/programs/stormwater/construction.shtml

Field Methods for Macroinvertebrate Collections

In collecting macroinvertebrate samples, the discharger shall use the “Reachwide Benthos (Multi-habitat) Procedure” specified in *Standard Operating Procedures for Collecting Benthic Macroinvertebrate Samples and Associated Physical and Chemical Data for Ambient Bioassessments in California* (Ode 2007).¹

Physical - Habitat Assessment Methods

The discharger shall conduct, concurrently with all required macroinvertebrate collections, the “Full” suite of physical habitat characterization measurements as specified in *Standard Operating Procedures for Collecting Benthic Macroinvertebrate Samples and Associated Physical and Chemical Data for Ambient Bioassessments in California* (Ode 2007), and as summarized in the Surface Water Ambient Monitoring Program’s *Stream Habitat Characterization Form — Full Version*.

Laboratory Methods

Macroinvertebrates shall be identified and classified according to the Standard Taxonomic Effort (STE) Level I of the Southwestern Association of Freshwater Invertebrate Taxonomists (SAFIT),² and using a fixed-count of 600 organisms per sample.

Quality Assurance

The discharger or its consultant(s) shall have and follow a quality assurance (QA) plan that covers the required bioassessment monitoring. The QA plan shall include, or be supplemented to include, a specific requirement for external QA checks (i.e., verification of taxonomic identifications and correction of data where

¹ This document is available on the Internet at: http://www.swrcb.ca.gov/swamp/docs/phab_sopr6.pdf.
http://swamp.mpsl.mml.calstate.edu/wp-content/uploads/2009/04/swamp_sop_bioassessment_collection_020107.pdf.

² The current SAFIT STEs (28 November 2006) list requirements for both the Level I and Level II taxonomic effort, and are located at: http://www.swrcb.ca.gov/swamp/docs/safit/ste_list.pdf
http://www.safit.org/Docs/ste_list.pdf. When new editions are published by SAFIT, they will supersede all previous editions. All editions will be posted at the State Water Board’s SWAMP website.

errors are identified). External QA checks shall be performed on one of the discharger's macroinvertebrate samples collected per calendar year, or ten percent of the samples per year (whichever is greater). QA samples shall be randomly selected. The external QA checks shall be paid for by the discharger, and performed by the California Department of Fish and Game's Aquatic Bioassessment Laboratory. An alternate laboratory with equivalent or better expertise and performance may be used if approved in writing by State Water Board staff.

Sample Preservation and Archiving

The original sample material shall be stored in 70 percent ethanol and retained by the discharger until: 1) all QA analyses specified herein and in the relevant QA plan are completed; and 2) any data corrections and/or re-analyses recommended by the external QA laboratory have been implemented. The remaining subsampled material shall be stored in 70 percent ethanol and retained until completeness checks have been performed according to the relevant QA plan. The identified organisms shall be stored in 70 percent ethanol, in separate glass vials for each final ID taxon. (For example, a sample with 45 identified taxa would be archived in a minimum of 45 vials, each containing all individuals of the identified taxon.) Each of the vials containing identified organisms shall be labeled with taxonomic information (i.e., taxon name, organism count) and collection information (i.e., site name/site code, waterbody name, date collected, method of collection). The identified organisms shall be archived (i.e., retained) by the discharger for a period of not less than three years from the date that all QA steps are completed, and shall be checked at least once per year and "topped off" with ethanol to prevent desiccation. The identified organisms shall be relinquished to the State Water Board upon request by any State Water Board staff.

Data Submittal

The macroinvertebrate results (i.e., taxonomic identifications consistent with the specified SAFIT STEs, and number of organisms within each taxa) shall be submitted to the State Water Board in electronic format. The State Water Board's Surface Water Ambient Monitoring Program (SWAMP) is currently developing standardized formats for reporting bioassessment data. All bioassessment data collected after those formats become available shall be submitted using the SWAMP formats. Until those formats are available, the biological data shall be submitted in MS-Excel (or equivalent) format.³

The physical/habitat data shall be reported using the standard format titled *SWAMP Stream Habitat Characterization Form — Full Version*.⁴

³ Any version of Excel, 2000 or later, may be used.

⁴ Available at:

http://www.waterboards.ca.gov/water_issues/programs/swamp/docs/reports/fieldforms_fullversion052908.pdf

Invasive Species Prevention

In conducting the required bioassessment monitoring, the discharger and its consultants shall take precautions to prevent the introduction or spread of aquatic invasive species. At minimum, the discharger and its consultants shall follow the recommendations of the California Department of Fish and Game to minimize the introduction or spread of the New Zealand mudsnail.⁵

⁵ Instructions for controlling the spread of NZ mudsnails, including decontamination methods, can be found at: <http://www.dfg.ca.gov/invasives/mudsnail/>
More information on AIS More information on AIS
http://www.waterboards.ca.gov/water_issues/programs/swamp/ais/

Appendix 4 Non Sediment TMDLs

Region 1 Lost River-DIN and CBOD

Region 1 Source: Cal Trans Construction TMDL Completion Date: 12 30 2008 TMDL Type: River, Lake Watershed Area= 2996 mi ²	Pollutant Stressors/WLA	
	Dissolved inorganic nitrogen (DIN) (metric tons/yr)	Carbonaceous biochemical oxygen demand (CBOD) (metric tons/yr)
Lost River from the Oregon border to Tule Lake	.1	.2
Tule Lake Refuge	.1	.2
Lower Klamath Refuge	.1	.2

Region 2 San Francisco Bay-Mercury

Region 2 Source: Non-Urban Stormwater Runoff TMDL Type: Bay	Name	Pollutant Stressor/WLA	TMDL Completion Date
	San Francisco Bay	Mercury 25 kg/year	08 09 2006

Region 4 Ballona Creek-Metals and Selenium

Region 4 Source: NPDES General Construction TMDL Completion Date: 12 22 2005 TMDL Type: Creek	Pollutant Stressors/WLA							
	Copper (Cu)		Lead (Pb)		Selenium (Se)		Zinc (Zn)	
	g/day	g/day/acre	g/day	g/day/acre	g/day	g/day/acre	g/day	g/day/acre
Ballona Creek	4.94E-07 x Daily storm volume (L)	2.20E-10 x Daily storm volume (L)	1.62E-06 x Daily storm volume (L)	7.20E-10 x Daily storm volume (L)	1.37E-07 x Daily storm volume (L)	6.10E-11 x Daily storm volume (L)	3.27E-06 x Daily storm volume (L)	1.45E-09 x Daily storm volume (L)

General Construction Storm Water Permits:

Waste load allocations will be incorporated into the State Board general permit upon renewal or into a watershed-specific general permit developed by the Regional Board.

- Dry-weather Implementation Non-storm water flows authorized by the General Permit for Storm Water Discharges Associated with Construction Activity (Water Quality Order No. 99-08 DWQ), or any successor order, are exempt from the dry-weather waste load allocation equal to zero as long as they comply with the provisions of sections C.3 and A.9 of the Order No. 99-08 DWQ, which state that these authorized non-storm discharges shall be:
 - (1) infeasible to eliminate
 - (2) comply with BMPs as described in the Storm Water Pollution Prevention Plan prepared by the permittee, and
 - (3) not cause or contribute to a violation of water quality standards, or comparable provisions in any successor order.
 Unauthorized non-storm water flows are already prohibited by Order No. 99-08 DWQ.
- Wet-weather Implementation Within seven years of the effective date of the TMDL, the construction industry will submit the results of BMP effectiveness studies to determine BMPs that will achieve compliance with the final waste load allocations assigned to construction storm water permittees.
- Regional Board staff will bring the recommended BMPs before the Regional Board for consideration within eight years of the effective date of the TMDL.
- General construction storm water permittees will be considered in compliance with final waste load allocations if they implement these Regional Board approved BMPs. All permittees must implement the approved BMPs within nine years of the effective date of the TMDL. If no effectiveness studies are conducted and no BMPs are approved by the Regional Board within eight years of the effective date of the TMDL, each general construction storm water permit holder will be subject to site-specific BMPs and monitoring requirements to demonstrate compliance with final waste load allocations.

Region 4 Calleaguas Creek-OC Pesticides, PCBs, and Siltation**Interim Requirements**

Region 4 Calleaguas Creek	Pollutant Stressor	WLA Daily Max (µg/L)	WLA Monthly Ave (µg/L)
Source: Minor NPDES point sources/WDRs	Chlordane	1.2	0.59
TMDL Completion Date: 3 14 2006	4,4-DDD	1.7	0.84
TMDL Type:Creek	4,4-DDE	1.2	0.59
	4,4-DDT	1.2	0.59
	Dieldrin	0.28	0.14
	PCB's	0.34	0.17
	Toxaphene	0.33	0.16

Final WLA (ng/g)							
Region 4 Calleguas Creek Source: Stormwater Permittees TMDL Completion Date: 3 14 2006 TMDL Type:Creek	Chlordane	4,4-DDD	4,4-DDE	4,4-DDT	Dieldrin	PCB's	Toxaphene
Mugu Lagoon*	3.3	2.0	2.2	0.3	4.3	180.0	360.0
Calleguas Creek	3.3	2.0	1.4	0.3	0.2	120.0	0.6
Revolon Slough (SW)*	0.9	2.0	1.4	0.3	0.1	130.0	1.0
Arroyo Las posas(SW)*	3.3	2.0	1.4	0.3	0.2	120.0	0.6
Arroyo Simi	3.3	2.0	1.4	0.3	0.2	120.0	0.6
Conejo Creek	3.3	2.0	1.4	0.3	0.2	120.0	0.6
Interim Requirements (ng/g)							
Mugu Lagoon*	25.0	69.0	300.0	39.0	19.0	180.	22900.0
Calleguas Creek	17.0	66.0	470.0	110.0	3.0	3800.0	260.0
Revolon Slough (SW)*	48.0	400.0	1600.0	690.0	5.7	7600.0	790.0
Arroyo Las posas(SW)*	3.3	290.0	950.0	670.0	1.1	25700.0	230.0
Arroyo Simi	3.3	14.0	170.0	25.0	1.1	25700.0	230.0
Conejo Creek	3.4	5.3	20.0	2.0	3.0	3800.0	260.0

*(SW)=Subwatershed

*Mugu Lagoon includes Duck pond/Agricultural Drain/Mugu/Oxnard Drain #2

Compliance with sediment based WLAs is measured as an instream annual average at the base of each subwatershed where the discharges are located.

Region 4 Calleguas Creek-Salts

Final Dry Weather Pollutant WLA (mg/L)					
Region 4 Calleguas Creek Source Permitted Stormwater Dischargers TMDL Completion Date: 12 2 2008 TMDL Type:Creek	Critical Condition Flow Rate (mgd)	Chloride (lb/day)	TDS (lb/day)	Sulfate (lb/day)	Boron (lb/day)
Simi	1.39	1738.0	9849.0	2897.0	12.0
Las Posas	0.13	157.0	887.0	261.0	N/A
Conejo	1.26	1576.0	8931.0	2627.0	N/A

Camarillo	0.06	72.0	406.0	119.0	N/A
Pleasant Valley (Calleguas)	0.12	150.0	850.0	250.0	N/A
Pleasant Valley (Revolon)	0.25	314.0	1778.0	523.0	2.0
Dry Weather Interim Pollutant WLA (mg/L)					
	Chloride (mg/L)	TDS (mg/L)	Sulfate (mg/L)	Boron (mg/L)	
Simi	230.0	1720.0	1289.0	1.3	
Las Posas	230.0	1720.0	1289.0	1.3	
Conejo	230.0	1720.0	1289.0	1.3	
Camarillo	230.0	1720.0	1289.0	1.3	
Pleasant Valley (Calleguas)	230.0	1720.0	1289.0	1.3	
Pleasant Valley (Revolon)	230.0	1720.0	1289.0	1.3	

- General Construction permittees are assigned a dry weather wasteload allocation equal to the average dry weather critical condition flow rate multiplied by the numeric target for each constituent. Waste load allocations apply in the receiving water at the base of each subwatershed. Dry weather allocations apply when instream flow rates are below the 86th percentile flow and there has been no measurable precipitation in the previous 24 hours.
- Because wet weather flows transport a large mass of salts at low concentrations, these dischargers meet water quality objectives during wet weather.
- Interim limits are assigned for dry weather discharges from areas covered by NPDES stormwater permits to allow time to implement appropriate actions. The interim limits are assigned as concentration based receiving water limits set to the 95th percentile of the discharger data as a monthly average limit except for chloride. The 95th percentile for chloride was 267 mg/L which is higher than the recommended criteria set forth in the Basin Plan for protection of sensitive beneficial uses including aquatic life. Therefore, the interim limit for chloride for Permitted Stormwater Dischargers is set equal to 230 mg/L to ensure protection of sensitive beneficial uses in the Calleguas Creek watershed.

Region 4 San Gabriel River and Tributaries-Metals and Selenium

Region 4 San Gabriel River and Tributaries Source: Construction Stormwater Dischargers TMDL Completion Date: 3 2007 TMDL Type: Creek	Pollutant Stressor	Wet weather Allocations	Dry Weather Allocations	% of Watershed
--	---------------------------	--------------------------------	--------------------------------	-----------------------

San Gabriel Reach 2	Lead (Pb)	0.7% * 166 µg/l * Daily Storm Vol	N/A	0.7%
San Gabriel Reach 2	Lead (Pb) Mass based	0.8 kg/d	N/A	0.7%
Coyote Creek	Copper (Cu)	0.285 kg/d	0	5.0%
Coyote Creek	Lead (Pb)	1.70 kg/d	N/A	5.0%
Coyote Creek	Zinc (Zn)	2.4 kg/d	N/A	5.0%
San Jose Creek Reach 1 and 2	Selenium	5 µg/L	5 µg/L	5.0%

Wet-weather allocations for lead in San Gabriel River Reach 2. Concentration-based allocations apply to non-stormwater NPDES discharges. Stormwater allocations are expressed as a percent of load duration curve. Mass-based values presented in table are based on a flow of 260 cfs (daily storm volume = 6.4×10^8 liters).

There are 1555 acres of water in the entire watershed, 37.4 acres of water in the Reach 1 subwatershed (2.4%), and 269 acres in the Coyote Creek subwatershed (17%).

General Construction Storm Water Permits

Waste load allocations for the general construction storm water permits may be incorporated into the State Board general permit upon renewal or into a watershed-specific general permit developed by the Regional Board. An estimate of direct atmospheric deposition is developed based on the percent area of surface water in the watershed. Approximately 0.4% of the watershed area draining to San Gabriel River Reach 2 is comprised of water and approximately 0.2% of the watershed area draining to Coyote Creek is comprised of water.

Region 4 The Harbor Beaches of Ventura County-Bacteria

The TMDL has a multi-part numeric target based on the bacteriological water quality objectives for marine water to protect the water contact recreation use. These targets are the most appropriate indicators of public health risk in recreational waters. Bacteriological objectives are set forth in Chapter 3 of the Basin Plan. The objectives are based on four bacteria indicators and include both geometric mean limits and single sample limits. The Basin Plan objectives that serve as the numeric targets for this TMDL are:

The General NPDES Construction permit is seen as a minor contributor and is given no allocation

General NPDES permits, individual NPDES permits, the Statewide Industrial Storm Water General Permit, the Statewide Construction Activity Storm Water General Permit, and WDR permittees in the Channel Islands Harbor subwatershed are assigned WLAs of zero (0) days of allowable exceedances for all three time periods and for the single sample limits and the rolling 30-day geometric mean. Any future enrollees under a general NPDES permit, individual NPDES permit, the Statewide Industrial Storm Water General Permit, the Statewide Construction Activity Storm Water General Permit, and WDR will also be subject to a WLA of zero (0) days of allowable exceedances.

Region 4 Resolution No. 03-009 Los Angeles River and Tributaries-Nutrients

Minor Point Sources

Waste loads are allocated to minor point sources enrolled under NPDES or WDR permits including but not limited to Tapia WRP, Whittier Narrows WRP, Los Angeles Zoo WRP, industrial and construction stormwater, and municipal storm water and urban runoff from municipal separate storm sewer systems (MS4s)

Region 4 Minor Point Sources for NPDES/WDR Permits TMDL Completion Date: 7 10 2003 TMDL Type: River	Pollutant Stressor/WLA				
	Total Ammonia (NH ₃)		Nitrate-nitrogen (NO ₃ -N)	Nitrite-nitrogen (NO ₂ -N)	NO ₃ -N + NO ₃ -N
	1 Hr Ave mg/l	30 Day Ave mg/l	30 Day Ave mg/l		30 Day Ave mg/l
LA River Above Los Angeles-Glendale WRP (LAG)	4.7	1.6	8.0	1.0	8.0
LA River Below LAG	8.7	2.4	8.0	1.0	8.0
Los Angeles Tributaries	10.1	2.3	8.0	1.0	8.0

Malibu Creek Attachment A to Resolution No. 2004-019R-Bacteria

12 13 2004 The WLAs for permittees under the NPDES General Stormwater Construction Permit are zero (0) days of allowable exceedances for all three time periods and for the single sample limits and the rolling 30-day geometric mean.

Region 4 Marina del Rey Harbor, Mothers' Beach and Back Basins

Attachment A to Resolution No. 2003-012-Bacteria

8 7 2003 As discussed in "Source Analysis", discharges from general NPDES permits, general industrial storm water permits and general construction storm water permits are not expected to be a significant source of bacteria. Therefore, the WLAs for these discharges are zero (0) days of allowable exceedances for all three time periods and for the single sample limits and the rolling 30-day geometric mean. Any future enrollees under a general NPDES permit, general industrial storm water permit or general construction storm water permit within the MdR Watershed will also be subject to a WLA of zero days of allowable exceedances.

Region 4 San Gabriel River and Tributaries-Metals and Selenium

Dry Weather Selenium WLA

A zero WLA is assigned to the industrial and construction stormwater permits during dry weather. Non-storm water discharges are already prohibited or restricted by existing general permits.

Region 4 General Construction Permittees TMDL Completion Date: 7 13 2006 TMDL Type: River	Total Recoverable Metals (kg/day)		
	Copper (Cu) Kg/day	Lead (Pb) Kg/day	Zinc (Zn) Kg/day
San Gabriel River Reach 2 and upstream reaches/tributaries	XXXX	Daily storm volume x 1.24 µg/L	XXXX
Coyote Creek and Tributaries	Daily storm volume x 0.7 µg/L	Daily storm volume x 4.3 µg/L	Daily storm volume x 6.2 µg/L

Each enrollee under the general construction stormwater permit receives a WLA on a per acre basis

Region 4 General Construction Permittees TMDL Completion Date: 7 13 2006 TMDL Type: River	Total Recoverable Metals (kg/day/acre)		
	Copper (Cu) Kg/acre/day	Lead (Pb) Kg/acre/day	Zinc (Zn) Kg/acre/day
San Gabriel River Reach 2 and upstream reaches/tributaries	XXXX	Daily storm volume x 0.56 µg/L	XXXX

Coyote Creek and Tributaries	Daily storm volume x 0.12 µg/L	Daily storm volume x 0.70 µg/L	Daily storm volume x 1.01 µg/L
------------------------------	-----------------------------------	-----------------------------------	-----------------------------------

For the general industrial and construction storm water permits, the daily storm volume is measured at USGS station 11085000 for discharges to Reach 2 and above and at LACDPW flow gauge station F354-R for discharges to Coyote Creek.

General construction storm water permits

WLAs will be incorporated into the State Board general permit upon renewal or into a watershed-specific general permit developed by the Regional Board.

Dry-weather implementation

Non-storm water flows authorized by the General Permit for Storm Water Discharges Associated with Construction Activity (NPDES Permit No. CAS000002), or any successor permit, are exempt from the dry-weather WLA equal to zero as long as they comply with the provisions of sections C.3.and A.9 of the Order No. 99-08 DWQ, which state that these authorized non-storm discharges shall be (1) infeasible to eliminate (2) comply with BMPs as described in the Storm Water Pollution Prevention Plan prepared by the permittee, and (3) not cause or contribute to a violation of water quality standards, or comparable provisions in any successor order. Unauthorized non-storm water flows are already prohibited by Permit No. CAS000002.

Upon permit issuance, renewal, or re-opener

Non-storm water flows not authorized by Order No. 99-08 DWQ, or any successor order, shall achieve dry-weather WLAs. WLAs shall be expressed as NPDES water quality-based effluent limitations specified in accordance with federal regulations and state policy on water quality control. Effluent limitations may be expressed as permit conditions, such as the installation, maintenance, and monitoring of Regional Board-approved BMPs.

Six years from the effective date of the TMDL

The construction industry will submit the results of wet-weather BMP effectiveness studies to the Los Angeles Regional Board for consideration. In the event that no effectiveness studies are conducted and no BMPs are approved, permittees shall be subject to site-specific BMPs and monitoring to demonstrate BMP effectiveness.

Seven years from the effective date of the TMDL

The Los Angeles Regional Board will consider results of the wet weather BMP effectiveness studies and consider approval of BMPs.

Eight years from the effective date of the TMDL

All general construction storm water permittees shall implement Regional Board-approved BMPs.

Region 8 RESOLUTION NO. R8-2007- 0024

Total Maximum Daily Loads (TMDLs) for San Diego Creek, Upper and Lower Newport Bay, Orange County, California

Region 8 NPDES Construction Permit TMDL Completion Date: 1 24 1995 TMDL Type: River, Cr, Bay	Organochlorine Compounds							
	Total DDT		Chlordane		Total PCBs		Toxaphene	
	g/day	g/yr	g/day	g/yr	g/day	g/yr	g/day	g/yr
San Diego Creek	.27	99.8	.18*	64.3*	.09*	31.5*	.004	1.5
Upper Newport Bay	.11	40.3	.06	23.4	.06	23.2	X	X
Lower Newport Bay	.04	14.9	.02	8.6	.17	60.7	X	X

*Red= Informational WLA only, not for enforcement purposes

Organochlorine Compounds TMDLs Implementation Tasks and Schedule

Regional Board staff shall develop a SWPPP Improvement Program that identifies the Regional Board’s expectations with respect to the content of SWPPPs, including documentation regarding the selection and implementation of BMPs, and a sampling and analysis plan. The Improvement Program shall include specific guidance regarding the development and implementation of monitoring plans, including the constituents to be monitored, sampling frequency and analytical protocols. The SWPPP Improvement Program shall be completed by *(the date of OAL approval of this BPA)*. **No later than two months** from completion of the Improvement Program, Board staff shall assure that the requirements of the Program are communicated to interested parties, including dischargers with existing authorizations under the General Construction Permit. Existing, authorized dischargers shall revise their project SWPPPs as needed to address the Program requirements as soon as possible but **no later than (three months of completion of the SWPPP Improvement Program)**. Applicable SWPPPs that do not adequately address the Program requirements shall be considered inadequate and enforcement by the Regional Board shall proceed accordingly. The Caltrans and Orange County MS4 permits shall be revised as needed to assure that the permittees communicate the Regional Board’s SWPPP expectations, based on the SWPPP Improvement Program, with the Standard Conditions of Approval.

Appendix 4 Sediment TMDLs

Implemented Sediment TMDLs in California. Construction was listed as a source in all fo these TMDLs in relation to road construction. Although construction was mentioned as a source, it was not given a specific allocation amount. The closest allocation amount would be for the road activity management WLA. **Implementation Phase** – Adoption process by the Regional Board, the State Water Resources Control Board, the Office of Administrative Law, and the US Environmental Protection Agency completed and TMDL being implemented.

A. Region	Type	Name	Pollutant Stressor	Potential Sources	TMDL Completion Date	Watershed Acres	WLA tons mi² yr
1 R1.epa.albionfinaltmdl	R	Albion River	Sedimentation	Road Construction	2001	43 acres	See A (table 6)

B Region	Type	Name	Pollutant Stressor	Potential Sources	TMDL Completion Date	Watershed Acres	WLA tons mi² yr
1 R1.epa.EelR-middle.mainSed.temp	R	Middle Main Eel River and Tributaries (from Dos Rios to the South Fork)	Sedimentation	Road Construction	2005-2006	521 mi ²	100

C Region	Type	Name	Pollutant Stressor	Potential Sources	TMDL Completion Date	Watershed Acres	WLA tons mi² yr
1 R1.epa.EelRsouth.sed.temp	R	South Fork Eel River	Sedimentation	Road Construction	12 1999	See chart	473

D Region	Type	Name	Pollutant Stressor	Potential Sources	TMDL Completion Date	Watershed Acres	WLA tons mi² yr
1 R1.epa.bigfinaltmdl	R	Big River	Sedimentation	Road Construction	12 2001	181 mi ² watershed drainage	TMDL = loading capacity = nonpoint sources + background =

							393 t mi ² yr
--	--	--	--	--	--	--	--------------------------

E Region	Type	Name	Pollutant Stressor	Potential Sources	TMDL Completion Date	Watershed Acres	WLA tons mi² yr
1 R1.epa.EelR-lower.Sed.temp-121807-signed	R	Lower Eel River	Sedimentation	Road Construction	12 2007	300 square-mile watershed	898

F Region	Type	Name	Pollutant Stressor	Potential Sources	TMDL Completion Date	Watershed Acres	WLA tons mi² yr
1 R1.epa.EelR-middle.Sed.temp-	R	Middle Fork Eel River	Sedimentation	Road Construction	12 2003	753 mi ² (approx. 482,000 acres)	82

G Region	Type	Name	Pollutant Stressor	Potential Sources	TMDL Completion Date	Watershed Acres Mi²	WLA tons mi² yr
1 R1.epa.EelRnorth-Sed.temp.final-121807-signed	R	North Fork Eel River	Sedimentation	Road Construction	12 30 2002	289 (180,020 acres)	20

H Region	Type	Name	Pollutant Stressor	Potential Sources	TMDL Completion Date	Watershed Acres Mi²	WLA tons mi² yr
1 R1.epa.EelR-upper.mainSed.temp-	R	Upper Main Eel River and Tributaries (including Tomki Creek, Outlet Creek and Lake Pillsbury)	Sedimentation	Road Construction	12 29 2004	688 (approx. 440,384 acres)	14

I Region	Type	Name	Pollutant Stressor	Potential Sources	TMDL Completion Date	Watershed Acres	WLA tons mi ² yr
1 R1.epa.gualalafina ltmdl	R	Gualala River	Sedimentation	Road Construction	Not sure	300 (191,145 acres)	7

J Region	Type	Name	Pollutant Stressor	Potential Sources	TMDL Completion Date	Watershed Acres mi ²	WLA tons mi ² yr
1 R1.epa.Mad- sed.turbidity	R	Mad River	Sedimentation	Road Construction	12 21 2007	480	174

K Region	Type	Name	Pollutant Stressor	Potential Sources	TMDL Completion Date	Watershed Acres mi ²	WLA tons mi ² yr
1 R1.epa.mattole.se diment	R	Mattole River	Sedimentation	Road Construction	12 30 2003	296	27 or 520+27 = 547

L Region	Type	Name	Pollutant Stressor	Potential Sources	TMDL Completion Date	Watershed Acres mi ²	WLA tons mi ² yr
1 R1.epa.navarro.se d.temp	R	Navarro River	Sedimentation	Road Construction	Not sure	315 (201,600 acres).	50

M Region	Type	Name	Pollutant Stressor	Potential Sources	TMDL Completion Date	Watershed Acres mi ²	WLA tons mi ² yr
1 R1.epa.noyo.sedi ment	R	Noyo River	Sedimentation	Road Construction	12 16 1999	113 (72,323 acres)	68 (three areas measured) Table 16 in the TMDL

N Region	Type	Name	Pollutant Stressor	Potential Sources	TMDL Completion Date	Watershed Acres mi²	WLA tons mi² yr
1 R1.epa.RedwoodCk.sed	Cr	Redwood Creek	Sedimentation	Road Construction	12 30 1998	278	1900 Total allocation

O Region	Type	Name	Pollutant Stressor	Potential Sources	TMDL Completion Date	Watershed Acres mi²	WLA – Roads tons mi² yr
1 R1.epa.tenmile.sed	R	Ten Mile River	Sedimentation	Road Construction	2000	120	9

P Region	Type	Name	Pollutant Stressor	Potential Sources	TMDL Completion Date	Watershed Acres mi²	WLA management tons mi² yr
1 R1.epa.trinity.sed	R	Trinity River	Sedimentation	Road Construction	12 20 2001	2000 of 3000 covered in this TMDL	See rows below
1	Cr	Horse Linto Creek	Sedimentation	Road Construction	12 20 2001	64	528
1	Cr	Mill creek and Tish Tang	Sedimentation	Road Construction	12 20 2001	39	210
1	Cr	Willow Creek	Sedimentation	Road Construction	12 20 2001	43	94
1	Cr	Campbell Creek and Supply Creek	Sedimentation	Road Construction	12 20 2001	11	1961
1	Cr	Lower Mainstem and Coon Creek	Sedimentation	Road Construction	12 20 2001	32	63
1	R	Reference	Sedimentation	Road	12 20 2001	434	24

		Subwatershed ¹		Construction			
1	Cr	Canyon Creek	Sedimentation	Road Construction	12 20 2001	64	326
1	R	Upper Tributaries ²	Sedimentation	Road Construction	12 20 2001	72	67
1	R	Middle Tributaries ³	Sedimentation	Road Construction	12 20 2001	54	53
1	R	Lower Tributaries ⁴	Sedimentation	Road Construction	12 20 2001	96	55
1	Cr	Weaver and Rush Creeks	Sedimentation	Road Construction	12 20 2001	72	169
1	Cr	Deadwood Creek Hoadley Gulch Poker Bar	Sedimentation	Road Construction	12 20 2001	47	68
1	L	Lewiston Lake	Sedimentation	Road Construction	12 20 2001	25	49
1	Cr	Grassvalley Creek	Sedimentation	Road Construction	12 20 2001	37	44
1	Cr	Indian Creek	Sedimentation	Road Construction	12 20 2001	34	81
1	Cr	Reading and Browns Creek	Sedimentation	Road Construction	12 20 2001	104	66
1	Cr	Reference Subwatersheds ⁵	Sedimentation	Road Construction	12 20 2001	235	281
1	L, Cr	Westside tributaries ⁶	Sedimentation	Road Construction	12 20 2001	93	105
1	R, Cr, G	Upper trinity ⁷	Sedimentation	Road Construction	12 20 2001	161	690
1	R, Cr, G	East Fork Tributaries ⁸	Sedimentation	Road Construction	12 20 2001	115	65

1
2
3
4
5
6
7
8

1	R, L	Eastside Tributaries ⁹	Sedimentation	Road Construction	12 20 2001	89	60
---	------	-----------------------------------	---------------	-------------------	------------	----	----

- 1 New River, Big French, Manzanita, North Fork, East Fork, North Fork
- 2 Dutch, Soldier, Oregon gulch, Conner Creek
- 3 Big Bar, Prairie Creek, Little French Creek
- 4 Swede, Italian, Canadian, Cedar Flat, Mill, McDonald, Hennessy, Quimby, Hawkins, Sharber
- 5 Stuarts Fork, Swift Creek, Coffee Creek
- 6 Stuart Arm, Stoney Creek, Mule Creek, East Fork, Stuart Fork, West Side Trinity Lake, Hatchet Creek, Buckeye Creek,
- 7 Upper Trinity River, Tangle Blue, Sunflower, Graves, Bear Upper Trinity Mainstream, Ramshorn Creek, Ripple Creek, Minnehaha Creek, Snowslide Gulch, Scorpion Creek
- 8 East Fork Trinity, Cedar Creek, Squirrel Gulch
- 9 East Side Tributaries, Trinity Lake

Q Region	Type	Name	Pollutant Stressor	Potential Sources	TMDL Completion Date	Watershed Acres mi ²	WLA tons mi ² yr
1 R1.epa.trinity.so.sed	R, Cr	South Fork Trinity River and Hayfork Creek	Sedimentation	Road Construction	12 1998	Not given, 19 miles long	33 (road total)

R Region	Type	Name	Pollutant Stressor	Potential Sources	TMDL Completion Date	Watershed Acres mi ²	WLA tons mi ² yr
1 R1.epa.vanduzen.sed	R, Cr	Van Duzen River and Yager Creek	Sedimentation	Various	12 16 1999	429	1353 total allocation
1		Upper Basin	Sedimentation	Road Construction			7
1		Middle Basin	Sedimentation	Road Construction			22
1		Lower Basin	Sedimentation	Road Construction			20

S Region	Type	Name	Pollutant Stressor	Potential	TMDL	Watershed	WLA tons mi ²
----------	------	------	--------------------	-----------	------	-----------	--------------------------

⁹

				Sources	Completion Date	Acres mi ²	yr	
6	R6.blackwood.sed	Cr	Blackwood Creek (Placer County)	Bedded Sediment	Various	9 2007	11	17272 total

T Region	Type	Name	Pollutant Stressor	Potential Sources	TMDL Completion Date	Watershed Acres mi ²	WLA tons mi ² yr	
6	R6.SquawCk.sed	R	Squaw Creek (Placer County)	Sedimentation /controllable sources	Various – basin plan amendment	4 13 2006	8.2	10,900

Adopted TMDLs for Construction Sediment Sources

Region	Type	Name	Pollutant Stressor	Potential Sources	TMDL Completion Date	Watershed Area mi ²	Waste load Allocation tons mi ² yr
8	R	Newport Bay San Diego Creek Watershed	Sedimentation	Construction Land Development	1999	2.24 (1432 acres)	125,000 tons per Year (no more than 13,000 tons per year from construction sites)

APPENDIX 5: Glossary

Active Areas of Construction

All areas subject to land surface disturbance activities related to the project including, but not limited to, project staging areas, immediate access areas and storage areas. All previously active areas are still considered active areas until final stabilization is complete. [The construction activity Phases used in this General Permit are the Preliminary Phase, Grading and Land Development Phase, Streets and Utilities Phase, and the Vertical Construction Phase.]

Active Treatment System (ATS)

A treatment system that employs chemical coagulation, chemical flocculation, or electrocoagulation to aid in the reduction of turbidity caused by fine suspended sediment.

Acute Toxicity Test

A chemical stimulus severe enough to rapidly induce a negative effect; in aquatic toxicity tests, an effect observed within 96 hours or less is considered acute.

Air Deposition

Airborne particulates from construction activities.

Approved Signatory

A person who has been authorized by the Legally Responsible Person to sign, certify, and electronically submit Permit Registration Documents, Notices of Termination, and any other documents, reports, or information required by the General Permit, the State or Regional Water Board, or U.S. EPA. The Approved Signatory must be one of the following:

1. For a corporation or limited liability company: a responsible corporate officer. For the purpose of this section, a responsible corporate officer means: (a) a president, secretary, treasurer, or vice-president of the corporation in charge of a principal business function, or any other person who performs similar policy or decision-making functions for the corporation or limited liability company; or (b) the manager of the facility if authority to sign documents has been assigned or delegated to the manager in accordance with corporate procedures;
2. For a partnership or sole proprietorship: a general partner or the proprietor, respectively;
3. For a municipality, State, Federal, or other public agency: a principal executive officer, ranking elected official, city manager, council president, or any other authorized public employee with managerial responsibility over the

construction or land disturbance project (including, but not limited to, project manager, project superintendent, or resident engineer);

4. For the military: any military officer or Department of Defense civilian, acting in an equivalent capacity to a military officer, who has been designated;
5. For a public university: an authorized university official;
6. For an individual: the individual, because the individual acts as both the Legally Responsible Person and the Approved Signatory; or
7. For any type of entity not listed above (e.g. trusts, estates, receivers): an authorized person with managerial authority over the construction or land disturbance project.

Beneficial Uses

As defined in the California Water Code, beneficial uses of the waters of the state that may be protected against quality degradation include, but are not limited to, domestic, municipal, agricultural and industrial supply; power generation; recreation; aesthetic enjoyment; navigation; and preservation and enhancement of fish, wildlife, and other aquatic resources or preserves.

Best Available Technology Economically Achievable (BAT)

As defined by USEPA, BAT is a technology-based standard established by the Clean Water Act (CWA) as the most appropriate means available on a national basis for controlling the direct discharge of toxic and nonconventional pollutants to navigable waters. The BAT effluent limitations guidelines, in general, represent the best existing performance of treatment technologies that are economically achievable within an industrial point source category or subcategory.

Best Conventional Pollutant Control Technology (BCT)

As defined by USEPA, BCT is a technology-based standard for the discharge from existing industrial point sources of conventional pollutants including biochemical oxygen demand (BOD), total suspended sediment (TSS), fecal coliform, pH, oil and grease.

Best Professional Judgment (BPJ)

The method used by permit writers to develop technology-based NPDES permit conditions on a case-by-case basis using all reasonably available and relevant data.

Best Management Practices (BMPs)

BMPs are scheduling of activities, prohibitions of practices, maintenance procedures, and other management practices to prevent or reduce the discharge of pollutants. BMPs also include treatment requirements, operating procedures,

and practices to control site runoff, spillage or leaks, sludge or waste disposal, or drainage from raw material storage.

Chain of Custody (COC)

Form used to track sample handling as samples progress from sample collection to the analytical laboratory. The COC is then used to track the resulting analytical data from the laboratory to the client. COC forms can be obtained from an analytical laboratory upon request.

Coagulation

The clumping of particles in a discharge to settle out impurities, often induced by chemicals such as lime, alum, and iron salts.

Common Plan of Development

Generally a contiguous area where multiple, distinct construction activities may be taking place at different times under one plan. A plan is generally defined as any piece of documentation or physical demarcation that indicates that construction activities may occur on a common plot. Such documentation could consist of a tract map, parcel map, demolition plans, grading plans or contract documents. Any of these documents could delineate the boundaries of a common plan area. However, broad planning documents, such as land use master plans, conceptual master plans, or broad-based CEQA or NEPA documents that identify potential projects for an agency or facility are not considered common plans of development.

Daily Average Discharge

The discharge of a pollutant measured during any 24-hour period that reasonably represents a calendar day for purposes of sampling. For pollutants with limitations expressed in units of mass, the daily discharge is calculated as the total mass of the pollutant discharged during the day. For pollutants with limitations expressed in other units of measurement (e.g., concentration) the daily discharge is calculated as the average measurement of the pollutant throughout the day (40 CFR 122.2). In the case of pH, the pH must first be converted from a log scale.

Debris

Litter, rubble, discarded refuse, and remains of destroyed inorganic anthropogenic waste.

Direct Discharge

A discharge that is routed directly to waters of the United States by means of a pipe, channel, or ditch (including a municipal storm sewer system), or through surface runoff.

Discharger

The Legally Responsible Person (see definition) or entity subject to this General Permit.

Dose Rate (for ATS)

In exposure assessment, dose (e.g. of a chemical) per time unit (e.g. mg/day), sometimes also called dosage.

Drainage Area

The area of land that drains water, sediment, pollutants, and dissolved materials to a common outlet.

Effluent

Any discharge of water by a discharger either to the receiving water or beyond the property boundary controlled by the discharger.

Effluent Limitation

Any numeric or narrative restriction imposed on quantities, discharge rates, and concentrations of pollutants which are discharged from point sources into waters of the United States, the waters of the contiguous zone, or the ocean.

Erosion

The process, by which soil particles are detached and transported by the actions of wind, water, or gravity.

Erosion Control BMPs

Vegetation, such as grasses and wildflowers, and other materials, such as straw, fiber, stabilizing emulsion, protective blankets, etc., placed to stabilize areas of disturbed soils, reduce loss of soil due to the action of water or wind, and prevent water pollution.

Field Measurements

Testing procedures performed in the field with portable field-testing kits or meters.

Final Stabilization

All soil disturbing activities at each individual parcel within the site have been completed in a manner consistent with the requirements in this General Permit.

First Order Stream

Stream with no tributaries.

Flocculants

Substances that interact with suspended particles and bind them together to form flocs.

Good Housekeeping BMPs

BMPs designed to reduce or eliminate the addition of pollutants to construction site runoff through analysis of pollutant sources, implementation of proper handling/disposal practices, employee education, and other actions.

Grading Phase (part of the Grading and Land Development Phase)

Includes reconfiguring the topography and slope including; alluvium removals; canyon cleanouts; rock undercuts; keyway excavations; land form grading; and stockpiling of select material for capping operations.

Hydromodification

Hydromodification is the alteration of the hydrologic characteristics of coastal and non-coastal waters, which in turn could cause degradation of water resources. Hydromodification can cause excessive erosion and/or sedimentation rates, causing excessive turbidity, channel aggradation and/or degradation.

Identified Organisms

Organisms within a sub-sample that is specifically identified and counted.

Inactive Areas of Construction

Areas of construction activity that are not active and those that have been active and are not scheduled to be re-disturbed for at least 14 days.

Index Period

The period of time during which bioassessment samples must be collected to produce results suitable for assessing the biological integrity of streams and rivers. Instream communities naturally vary over the course of a year, and sampling during the index period ensures that samples are collected during a time frame when communities are stable so that year-to-year consistency is obtained. The index period approach provides a cost-effective alternative to year-round sampling. Furthermore, sampling within the appropriate index period will yield results that are comparable to the assessment thresholds or criteria for a given region, which are established for the same index period. Because index periods differ for different parts of the state, it is essential to know the index period for your area.

K Factor

The soil erodibility factor used in the Revised Universal Soil Loss Equation (RUSLE). It represents the combination of detachability of the soil, runoff potential of the soil, and the transportability of the sediment eroded from the soil.

Legally Responsible Person

The Legally Responsible Person (LRP) will typically be the project proponent. The categories of persons or entities that are eligible to serve as the LRP are set forth below. For any construction or land disturbance project where multiple persons or entities are eligible to serve as the LRP, those persons or entities

shall select a single LRP. In exceptional circumstances, a person or entity that qualifies as the LRP may provide written authorization to another person or entity to serve as the LRP. In such a circumstance, the person or entity that provides the authorization retains all responsibility for compliance with the General Permit. Except as provided in category 2(d), a contractor who does not satisfy the requirements of any of the categories below is not qualified to be an LRP.

The following persons or entities may serve as an LRP:

1. A person, company, agency, or other entity that possesses a real property interest (including, but not limited to, fee simple ownership, easement, leasehold, or other rights of way) in the land upon which the construction or land disturbance activities will occur for the regulated site.
2. In addition to the above, the following persons or entities may also serve as an LRP:
 - a. For linear underground/overhead projects, the utility company, municipality, or other public or private company or agency that owns or operates the LUP;
 - b. For land controlled by an estate or similar entity, the person who has day-to-day control over the land (including, but not limited to, a bankruptcy trustee, receiver, or conservator);
 - c. For pollution investigation and remediation projects, any potentially responsible party that has received permission to conduct the project from the holder of a real property interest in the land; or
 - d. For U.S. Army Corp of Engineers projects, the U.S. Army Corps of Engineers may provide written authorization to its bonded contractor to serve as the LRP, provided, however, that the U.S. Army Corps of Engineers is also responsible for compliance with the general permit, as authorized by the Clean Water Act or the Federal Facilities Compliance Act.

Likely Precipitation Event

Any weather pattern that is forecasted to have a 50% or greater chance of producing precipitation in the project area. The discharger shall obtain likely precipitation forecast information from the National Weather Service Forecast Office (e.g., by entering the zip code of the project's location at <http://www.srh.noaa.gov/forecast>).

Maximum Allowable Threshold Concentration (MATC)

The allowable concentration of residual, or dissolved, coagulant/flocculant in effluent. The MATC shall be coagulant/flocculant-specific, and based on toxicity

testing conducted by an independent, third-party laboratory. A typical MATC would be:

The MATC is equal to the geometric mean of the NOEC (No Observed Effect Concentration) and LOEC (Lowest Observed Effect Concentration) Acute and Chronic toxicity results for most sensitive species determined for the specific coagulant. The most sensitive species test shall be used to determine the MATC.

Natural Channel Evolution

The physical trend in channel adjustments following a disturbance that causes the river to have more energy and degrade or aggrade more sediment. Channels have been observed to pass through 5 to 9 evolution types. Once they pass through the suite of evolution stages, they will rest in a new state of equilibrium.

Non-Storm Water Discharges

Discharges are discharges that do not originate from precipitation events. They can include, but are not limited to, discharges of process water, air conditioner condensate, non-contact cooling water, vehicle wash water, sanitary wastes, concrete washout water, paint wash water, irrigation water, or pipe testing water.

Non-Visible Pollutants

Pollutants associated with a specific site or activity that can have a negative impact on water quality, but cannot be seen through observation (ex: chlorine). Such pollutants being discharged are not authorized.

Numeric Action Level (NAL)

Level is used as a warning to evaluate if best management practices are effective and take necessary corrective actions. Not an effluent limit.

Original Sample Material

The material (i.e., macroinvertebrates, organic material, gravel, etc.) remaining after the subsample has been removed for identification.

pH

Unit universally used to express the intensity of the acid or alkaline condition of a water sample. The pH of natural waters tends to range between 6 and 9, with neutral being 7. Extremes of pH can have deleterious effects on aquatic systems.

Post-Construction BMPs

Structural and non-structural controls which detain, retain, or filter the release of pollutants to receiving waters after final stabilization is attained.

Preliminary Phase (Pre-Construction Phase - Part of the Grading and Land Development Phase)

Construction stage including rough grading and/or disking, clearing and grubbing operations, or any soil disturbance prior to mass grading.

Project

Qualified SWPPP Developer

Individual who is authorized to develop and revise SWPPPs.

Qualified SWPPP Practitioner

Individual assigned responsibility for non-storm water and storm water visual observations, sampling and analysis, and responsibility to ensure full compliance with the permit and implementation of all elements of the SWPPP, including the preparation of the annual compliance evaluation and the elimination of all unauthorized discharges.

Qualifying Rain Event

Any event that produces 0.5 inches or more precipitation with a 48 hour or greater period between rain events.

R Factor

Erosivity factor used in the Revised Universal Soil Loss Equation (RUSLE). The R factor represents the erosivity of the climate at a particular location. An average annual value of R is determined from historical weather records using erosivity values determined for individual storms. The erosivity of an individual storm is computed as the product of the storm's total energy, which is closely related to storm amount, and the storm's maximum 30-minute intensity.

Rain Event Action Plan (REAP)

Written document, specific for each rain event, that when implemented is designed to protect all exposed portions of the site within 48 hours of any likely precipitation event.

Remaining Sub sampled Material

The material (e.g., organic material, gravel, etc.) that remains after the organisms to be identified have been removed from the subsample for identification. (Generally, no macroinvertebrates are present in the remaining subsampled material, but the sample needs to be checked and verified using a complete Quality Assurance (QA) plan)

Routine Maintenance

Activities intended to maintain the original line and grade, hydraulic capacity, or original purpose of a facility.

Runoff Control BMPs

Measures used to divert runoff from offsite and runoff within the site.

Run-on

Discharges that originate offsite and flow onto the property of a separate project site.

Revised Universal Soil Loss Equation (RUSLE)

Empirical model that calculates average annual soil loss as a function of rainfall and runoff erosivity, soil erodibility, topography, erosion controls, and sediment controls.

Sampling and Analysis Plan

Document that describes how the samples will be collected, under what conditions, where and when the samples will be collected, what the sample will be tested for, what test methods and detection limits will be used, and what methods/procedures will be maintained to ensure the integrity of the sample during collection, storage, shipping and testing (i.e., quality assurance/quality control protocols).

Sediment

Solid particulate matter, both mineral and organic, that is in suspension, is being transported, or has been moved from its site of origin by air, water, gravity, or ice and has come to rest on the earth's surface either above or below sea level.

Sedimentation

Process of deposition of suspended matter carried by water, wastewater, or other liquids, by gravity. It is usually accomplished by reducing the velocity of the liquid below the point at which it can transport the suspended material.

Sediment Control BMPs

Practices that trap soil particles after they have been eroded by rain, flowing water, or wind. They include those practices that intercept and slow or detain the flow of storm water to allow sediment to settle and be trapped (e.g., silt fence, sediment basin, fiber rolls, etc.).

Settleable Solids (SS)

Solid material that can be settled within a water column during a specified time frame. It is typically tested by placing a water sample into an Imhoff settling cone and then allowing the solids to settle by gravity for a given length of time. Results are reported either as a volume (mL/L) or a mass (mg/L) concentration.

Sheet Flow

Flow of water that occurs overland in areas where there are no defined channels where the water spreads out over a large area at a uniform depth.

Site**Soil Amendment**

Any material that is added to the soil to change its chemical properties, engineering properties, or erosion resistance that could become mobilized by storm water.

Streets and Utilities Phase

Construction stage including excavation and street paving, lot grading, curbs, gutters and sidewalks, public utilities, public water facilities including fire hydrants, public sanitary sewer systems, storm sewer system and/or other drainage improvements.

Structural Controls

Any structural facility designed and constructed to mitigate the adverse impacts of storm water and urban runoff pollution

Suspended Sediment Concentration (SSC)

The measure of the concentration of suspended solid material in a water sample by measuring the dry weight of all of the solid material from a known volume of a collected water sample. Results are reported in mg/L.

Total Suspended Solids (TSS)

The measure of the suspended solids in a water sample includes inorganic substances, such as soil particles and organic substances, such as algae, aquatic plant/animal waste, particles related to industrial/sewage waste, etc. The TSS test measures the concentration of suspended solids in water by measuring the dry weight of a solid material contained in a known volume of a sub-sample of a collected water sample. Results are reported in mg/L.

Toxicity

The adverse response(s) of organisms to chemicals or physical agents ranging from mortality to physiological responses such as impaired reproduction or growth anomalies.

Turbidity

The cloudiness of water quantified by the degree to which light traveling through a water column is scattered by the suspended organic and inorganic particles it contains. The turbidity test is reported in Nephelometric Turbidity Units (NTU) or Jackson Turbidity Units (JTU).

Vertical Construction Phase

The Build out of structures from foundations to roofing, including rough landscaping.

Waters of the United States

Generally refers to surface waters, as defined by the federal Environmental Protection Agency in 40 C.F.R. § 122.2.¹

Water Quality Objectives (WQO)

Water quality objectives are defined in the California Water Code as limits or levels of water quality constituents or characteristics, which are established for the reasonable protection of beneficial uses of water or the prevention of nuisance within a specific area.

¹ The application of the definition of “waters of the United States” may be difficult to determine; there are currently several judicial decisions that create some confusion. If a landowner is unsure whether the discharge must be covered by this General Permit, the landowner may wish to seek legal advice.

This page intentionally left blank.

APPENDIX 6: Acronym List

ASBS	Areas of Special Biological Significance
ASTM	American Society of Testing and Materials; Standard Test Method for Particle-Size Analysis of Soils
ATS	Active Treatment System
BASMAA	Bay Area Storm water Management Agencies Association
BAT	Best Available Technology Economically Achievable
BCT	Best Conventional Pollutant Control Technology
BMP	Best Management Practices
BOD	Biochemical Oxygen Demand
BPJ	Best Professional Judgment
CAFO	Confined Animal Feeding Operation
CCR	California Code of Regulations
CEQA	California Environmental Quality Act
CFR	Code of Federal Regulations
CGP	NPDES General Permit for Storm Water Discharges Associated with Construction Activities
CIWQS	California Integrated Water Quality System
CKD	Cement Kiln Dust
COC	Chain of Custody
CPESC	Certified Professional in Erosion and Sediment Control
CPSWQ	Certified Professional in Storm Water Quality
CSMP	Construction Site Monitoring Program
CTB	Cement Treated Base
CTR	California Toxics Rule
CWA	Clean Water Act
CWC	California Water Code
CWP	Center for Watershed Protection
DADMAC	Diallyldimethyl-ammonium chloride
DDNR	Delaware Department of Natural Resources
DFG	Department of Fish and Game
DHS	Department of Health Services
DWQ	Division of Water Quality
EC	Electrical Conductivity
ELAP	Environmental Laboratory Accreditation Program
EPA	Environmental Protection Agency
ESA	Environmentally Sensitive Area
ESC	Erosion and Sediment Control
HSPF	Hydrologic Simulation Program Fortran
JTU	Jackson Turbidity Units
LID	Low Impact Development
LOEC	Lowest Observed Effect Concentration
LRP	Legally Responsible Person
LUP	Linear Underground/Overhead Projects

MATC	Maximum Allowable Threshold Concentration
MDL	Method Detection Limits
MRR	Monitoring and Reporting Requirements
MS4	Municipal Separate Storm Sewer System
MUSLE	Modified Universal Soil Loss Equation
NAL	Numeric Action Level
NEL	Numeric Effluent Limitation
NICET	National Institute for Certification in Engineering Technologies
NOAA	National Oceanic and Atmospheric Administration
NOEC	No Observed Effect Concentration
NOI	Notice of Intent
NOT	Notice of Termination
NPDES	National Pollutant Discharge Elimination System
NRCS	Natural Resources Conservation Service
NTR	National Toxics Rule
NTU	Nephelometric Turbidity Units
O&M	Operation and Maintenance
PAC	Polyaluminum chloride
PAM	Polyacrylamide
PASS	Polyaluminum chloride Silica/sulfate
POC	Pollutants of Concern
PoP	Probability of Precipitation
POTW	Publicly Owned Treatment Works
PRDs	Permit Registration Documents
PWS	Planning Watershed
QAMP	Quality Assurance Management Plan
QA/QC	Quality Assurance/Quality Control
REAP	Rain Event Action Plan
Regional Board	Regional Water Quality Control Board
ROWD	Report of Waste Discharge
RUSLE	Revised Universal Soil Loss Equation
RW	Receiving Water
SMARTS System	Storm water Multi Application Reporting and Tracking
SS	Settleable Solids
SSC	Suspended Sediment Concentration
SUSMP	Standard Urban Storm Water Mitigation Plan
SW	Storm Water
SWARM	Storm Water Annual Report Module
SWAMP	Surface Water Ambient Monitoring Program
SWMM	Storm Water Management Model
SWMP	Storm Water Management Program
SWPPP	Storm Water Pollution Prevention Plan
TC	Treatment Control
TDS	Total Dissolved Solids

TMDL	Total Maximum Daily Load
TSS	Total Suspended Solids
USACOE	U.S. Army Corps of Engineers
USC	United States Code
USEPA	United States Environmental Protection Agency
USGS	United States Geological Survey
WDID	Waste Discharge Identification Number
WDR	Waste Discharge Requirements
WLA	Waste Load Allocation
WET	Whole Effluent Toxicity
WRCC	Western Regional Climate Center
WQBEL	Water Quality Based Effluent Limitation
WQO	Water Quality Objective
WQS	Water Quality Standard

This page intentionally left blank.

APPENDIX 7: State and Regional Water Resources Control Board Contacts

NORTH COAST REGION (1)
5550 Skylane Blvd, Ste. A
Santa Rose, CA 95403
(707) 576-2220 FAX: (707)523-0135

SAN FRANCISCO BAY REGION (2)
1515 Clay Street, Ste. 1400
Oakland, CA 94612
(510) 622-2300 FAX: (510) 622-2640

CENTRAL COAST REGION (3)
895 Aerovista Place, Ste 101
San Luis Obispo, CA 93401
(805) 549-3147 FAX: (805) 543-0397

LOS ANGELES REGION (4)
320 W. 4th Street, Ste. 200
Los Angeles, CA 90013
(213) 576-6600 FAX: (213) 576-6640

LAHONTAN REGION (6 SLT)
2501 Lake Tahoe Blvd.
South Lake Tahoe, CA 96150
(530) 542-5400 FAX: (530) 544-2271

VICTORVILLE OFFICE (6V)
14440 Civic Drive, Ste. 200
Victorville, CA 92392-2383
(760) 241-6583 FAX: (760) 241-7308

CENTRAL VALLEY REGION (5S)
11020 Sun Center Dr., #200
Rancho Cordova, CA 95670-6114
(916) 464-3291 FAX: (916) 464-4645

FRESNO BRANCH OFFICE (5F)
1685 E St.
Fresno, CA 93706
(559) 445-5116 FAX: (559) 445-5910

REDDING BRANCH OFFICE (5R)
364 Knollcrest Drive, Ste. 205
Redding, CA 96002
(530) 224-4845 FAX: (530) 224-4857

COLORADO RIVER BASIN REGION (7)
73-720 Fred Waring Dr., Ste. 100
Palm Desert, CA 92260
(760) 346-7491 FAX: (760) 341-6820

SANTA ANA REGION (8)
3737 Main Street, Ste. 500
Riverside, CA 92501-3339
Phone (951) 782-4130 FAX: (951) 781-6288

SAN DIEGO REGION (9)
9174 Sky Park Court, Ste. 100
San Diego, CA 92123-4340
(858) 467-2952 FAX: (858) 571-6972

STATE WATER BOARD
PO Box 1977
Sacramento, CA 95812-1977
stormwater@waterboards.ca.gov

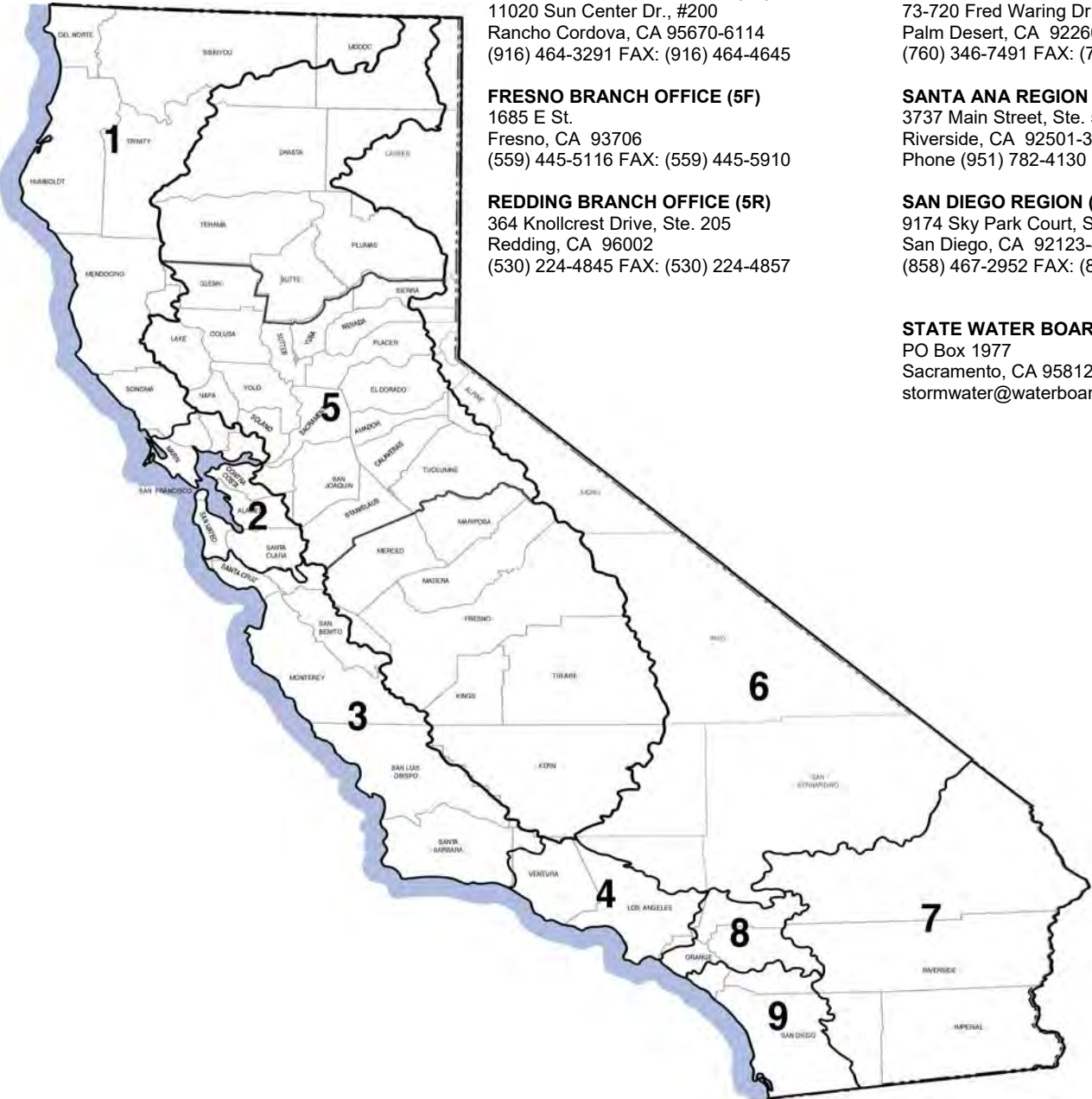

This page intentionally left blank.

APPENDIX III
SITE MAPS AND DRAWINGS

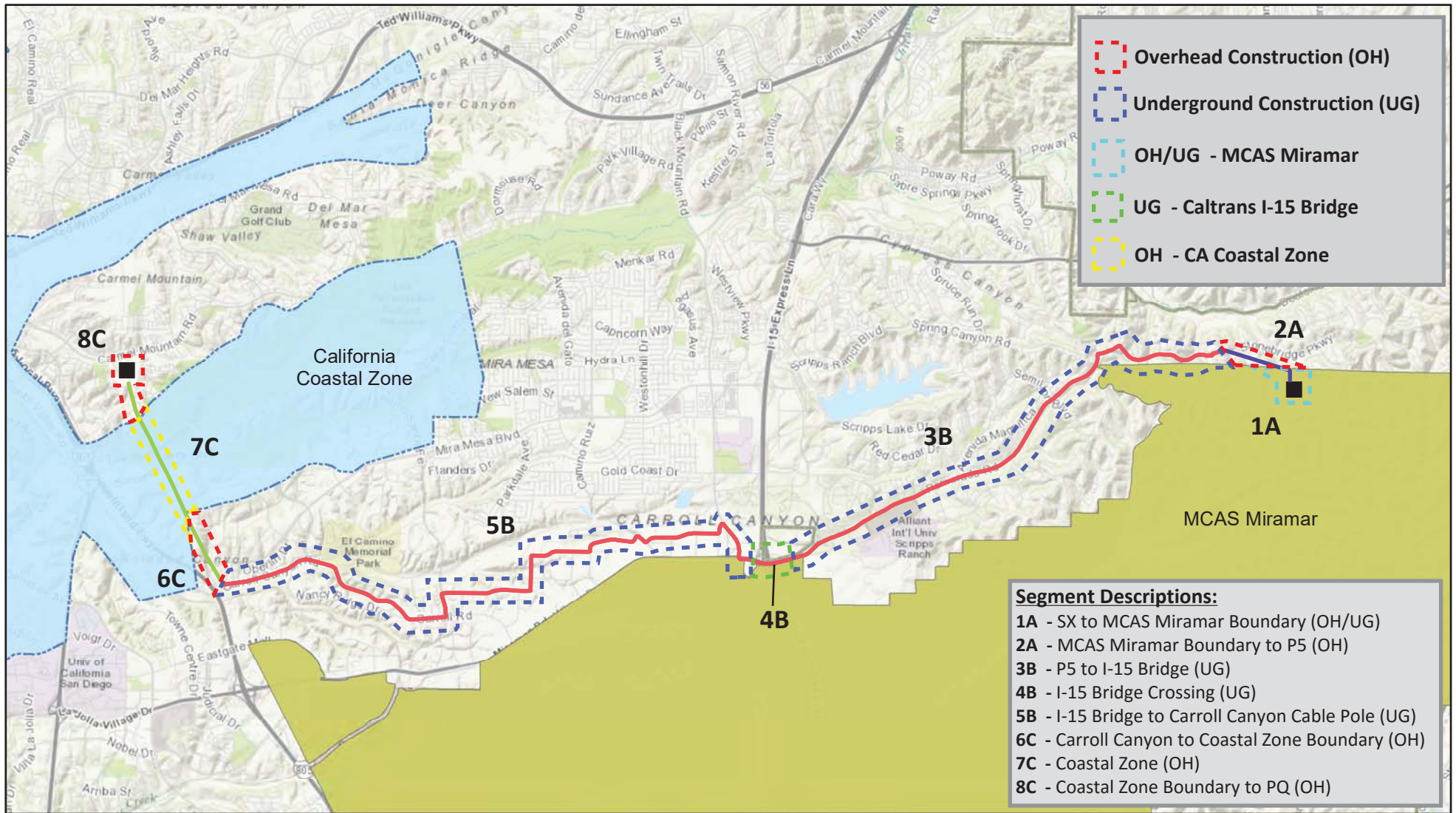

G:\SDGE_SX2PQandTL6961\SDGE_SunriseSX2PQMXD\AI15_CDP_Fig1.mxd

Sycamore to Peñasquitos 230kV Transmission Line Project Project Overview Map Figure 1

CONFIDENTIAL - PROPERTY OF SDG&E. FOR INTERNAL USE ONLY. UNAUTHORIZED DISSEMINATION PROHIBITED. THIS DOCUMENT SHALL BE TREATED AS CONFIDENTIAL PURSUANT TO Public Utilities Code Section 583, General Order 66-C, any applicable non-disclosure agreement, and/or the North American Electric Reliability Corporation's Rules of Procedure, Section 1500 et seq, and any other applicable federal and state laws and regulations. THIS MAP IS NOT SURVEY GRADE, and SDG&E makes no representations or warranties, expressed or implied, as to its accuracy, correctness, defensibility, completeness or any other standard or measure of quality or adequacy, or as to its fitness for use or intended use for any particular purpose. SDG&E disclaims all liability for your selection or use of this map or any consequences therefrom. *Certain technology used under license from AT&T Intellectual Property I, L.P. Copyright ©1998 - 2007 AT&T Intellectual Property I, L.P. All Rights Reserved.*

- Substation
- Segment A - New 230kV Overhead - New Poles and Conductor- 0.74 mile
- Segment B - 230kV Underground - New Duct and Cable - 11.45 miles
- Segment C - New 230kV Overhead - New Conductor on Existing Structures - 2.08 miles







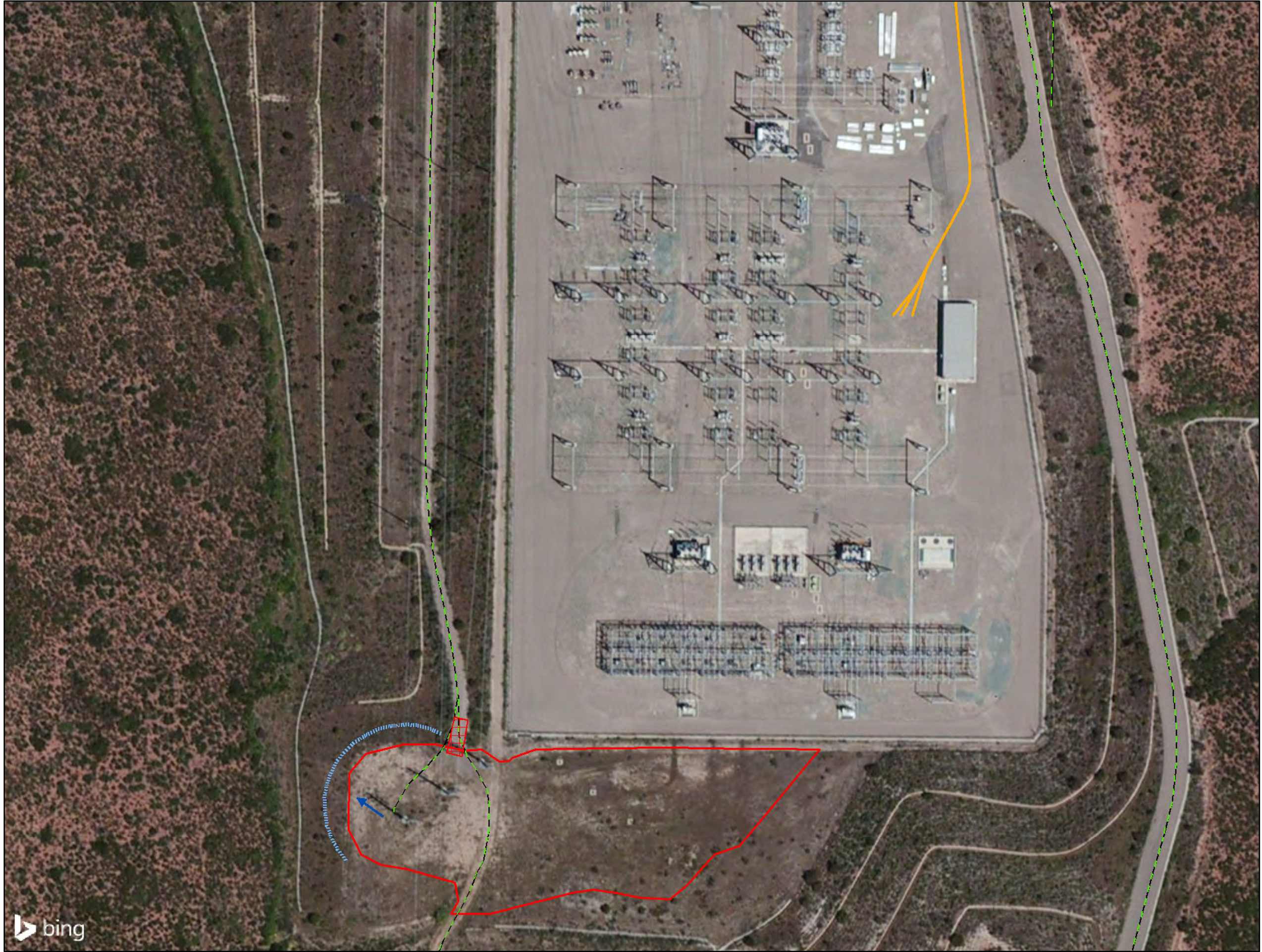

6/9/2016













**Sycamore to Peñasquitos
230kV Transmission
Line Project
SWPPP Detail Map
Sheet 1 of 68**

DRAFT

-  Tracking Control
-  Flow Direction
-  Silt Fence
-  Fiber Roll
-  Storm Drain Inlet Protection
-  Streams & Rivers

Project Features

-  Entrance Point
-  Project Overhead TL
-  Project Underground TL
-  Access Road
-  Underground Vault
-  Potential Staging Yards
-  Temporary Work Area
-  Permanent Impact

Notes:
Locations of perimeter control BMPs are not to scale. BMP locations are conceptual in nature and must be field-verified prior to construction. Protect all inlets where applicable. Staging yards may be active during any time of construction.

SDG&E is providing this map with the understanding that the map is not survey grade. Certain technology used under license from AT&T Intellectual Property I, L.P. Copyright ©1998 – 2007 AT&T Intellectual Property 1, L.P. All Rights Reserved.

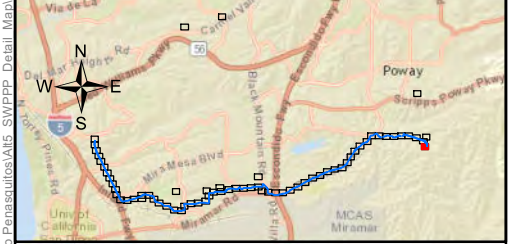
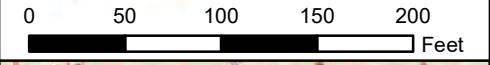

Service Layer Credits: Sources: Esri, HERE, DeLorme, USGS, Intermap, INCREMENT P, NRCan, Esri Japan, METI, Esri China (Hong Kong), Esri Korea, Esri (Thailand), MapmyIndia, NGCC, © OpenStreetMap contributors, and the GIS User Community © 2016 Microsoft Corporation © 2010 NAVTEQ © AND



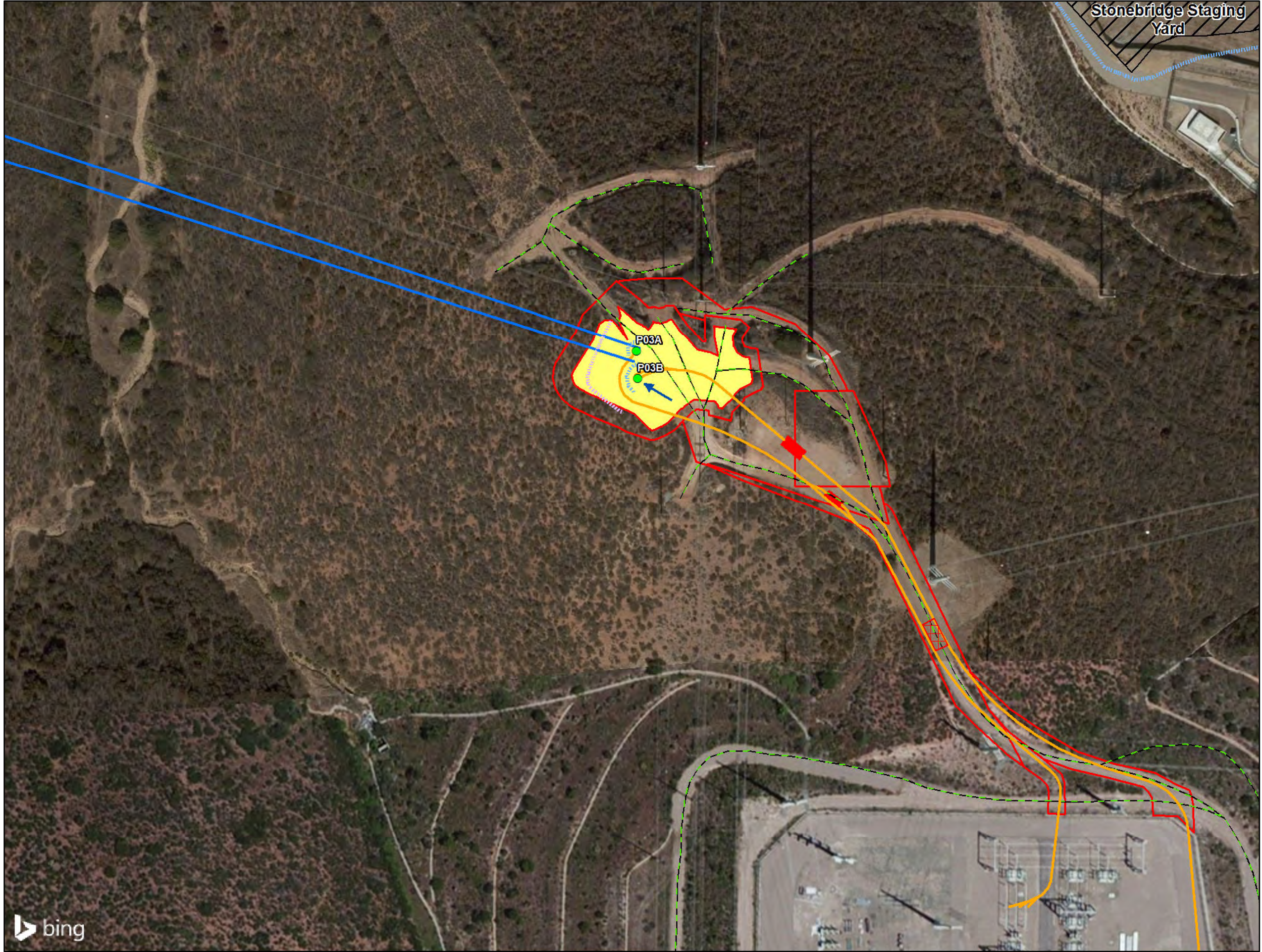

**Sycamore to Peñasquitos
230kV Transmission
Line Project
SWPPP Detail Map
Sheet 2 of 68**

- DRAFT**
- Tracking Control
 - Flow Direction
 - Silt Fence
 - Fiber Roll
 - Storm Drain Inlet Protection
 - Streams & Rivers
- Project Features**
- Entrance Point
 - Project Overhead TL
 - Project Underground TL
 - Access Road
 - Underground Vault
 - Potential Staging Yards
 - Temporary Work Area
 - Permanent Impact

Notes:
Locations of perimeter control BMPs are not to scale. BMP locations are conceptual in nature and must be field-verified prior to construction. Protect all inlets where applicable. Staging yards may be active during any time of construction.

SDG&E is providing this map with the understanding that the map is not survey grade. Certain technology used under license from AT&T Intellectual Property I, L.P. Copyright ©1998 – 2007 AT&T Intellectual Property 1, L.P. All Rights Reserved.

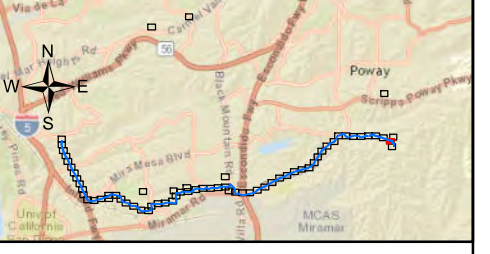
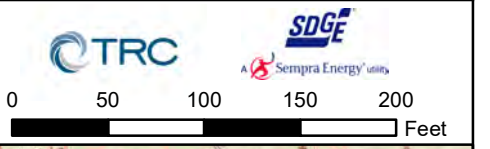

Service Layer Credits: Sources: Esri, HERE, DeLorme, USGS, Intermap, INCREMENT P, NRCan, Esri Japan, METI, Esri China (Hong Kong), Esri Korea, Esri (Thailand), MapmyIndia, NGCC, © OpenStreetMap contributors, and the GIS User Community © 2016 Microsoft Corporation © 2010 NAVTEQ © AND



**Sycamore to Peñasquitos
230kV Transmission
Line Project
SWPPP Detail Map
Sheet 3 of 68**

- DRAFT**
- Tracking Control
 - Flow Direction
 - Silt Fence
 - Fiber Roll
 - Storm Drain Inlet Protection
 - Streams & Rivers
- Project Features**
- Entrance Point
 - Project Overhead TL
 - Project Underground TL
 - Access Road
 - Underground Vault
 - Potential Staging Yards
 - Temporary Work Area
 - Permanent Impact

Notes:
Locations of perimeter control BMPs are not to scale. BMP locations are conceptual in nature and must be field-verified prior to construction. Protect all inlets where applicable. Staging yards may be active during any time of construction.

SDG&E is providing this map with the understanding that the map is not survey grade. Certain technology used under license from AT&T Intellectual Property I, L.P. Copyright ©1998 – 2007 AT&T Intellectual Property 1, L.P. All Rights Reserved.

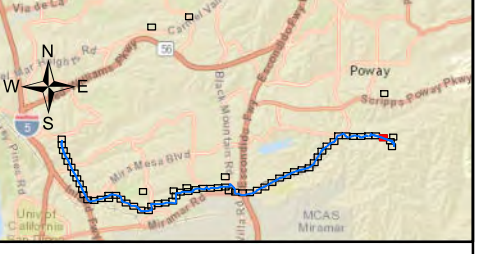
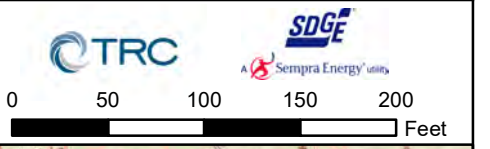

Service Layer Credits: Sources: Esri, HERE, DeLorme, USGS, Intermap, INCREMENT P, NRCan, Esri Japan, METI, Esri China (Hong Kong), Esri Korea, Esri (Thailand), MapmyIndia, NGCC, © OpenStreetMap contributors, and the GIS User Community © 2016 Microsoft Corporation © 2010 NAVTEQ © AND



**Sycamore to Peñasquitos
230kV Transmission
Line Project
SWPPP Detail Map
Sheet 4 of 68**

DRAFT

-  Tracking Control
-  Flow Direction
-  Silt Fence
-  Fiber Roll
-  Storm Drain Inlet Protection
-  Streams & Rivers
- Project Features**
-  Entrance Point
-  Project Overhead TL
-  Project Underground TL
-  Access Road
-  Underground Vault
-  Potential Staging Yards
-  Temporary Work Area
-  Permanent Impact

Notes:
Locations of perimeter control BMPs are not to scale. BMP locations are conceptual in nature and must be field-verified prior to construction. Protect all inlets where applicable. Staging yards may be active during any time of construction.

SDG&E is providing this map with the understanding that the map is not survey grade. Certain technology used under license from AT&T Intellectual Property I, L.P. Copyright ©1998 – 2007 AT&T Intellectual Property 1, L.P. All Rights Reserved.

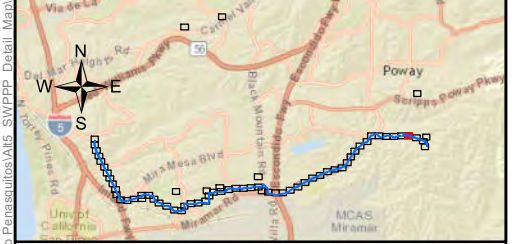
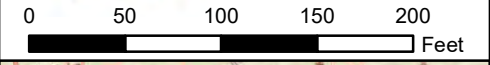

Service Layer Credits: Sources: Esri, HERE, DeLorme, USGS, Intermap, INCREMENT P, NRCan, Esri Japan, METI, Esri China (Hong Kong), Esri Korea, Esri (Thailand), MapmyIndia, NGCC, © OpenStreetMap contributors, and the GIS User Community © 2016 Microsoft Corporation © 2010 NAVTEQ © AND

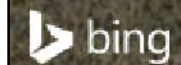



Sycamore to Peñasquitos 230kV Transmission Line Project SWPPP Detail Map Sheet 5 of 68

DRAFT

-  Tracking Control
-  Flow Direction
-  Silt Fence
-  Fiber Roll
-  Storm Drain Inlet Protection
-  Streams & Rivers
- Project Features**
-  Entrance Point
-  Project Overhead TL
-  Project Underground TL
-  Access Road
-  Underground Vault
-  Potential Staging Yards
-  Temporary Work Area
-  Permanent Impact

Notes:
Locations of perimeter control BMPs are not to scale. BMP locations are conceptual in nature and must be field-verified prior to construction. Protect all inlets where applicable. Staging yards may be active during any time of construction.

SDG&E is providing this map with the understanding that the map is not survey grade. Certain technology used under license from AT&T Intellectual Property L, L.P. Copyright ©1998 – 2007 AT&T Intellectual Property 1, L.P. All Rights Reserved.

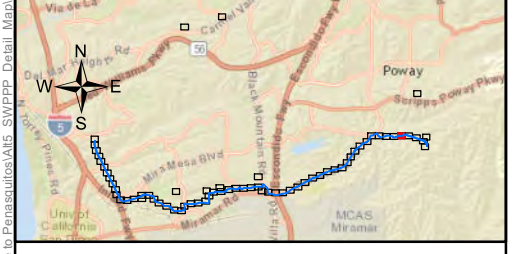

Service Layer Credits: Sources: Esri, HERE, DeLorme, USGS, Intermap, INCREMENT P, NRCan, Esri Japan, METI, Esri China (Hong Kong), Esri Korea, Esri (Thailand), MapmyIndia, NGCC, © OpenStreetMap contributors, and the GIS User Community
© 2016 Microsoft Corporation © 2010 NAVTEQ © AND

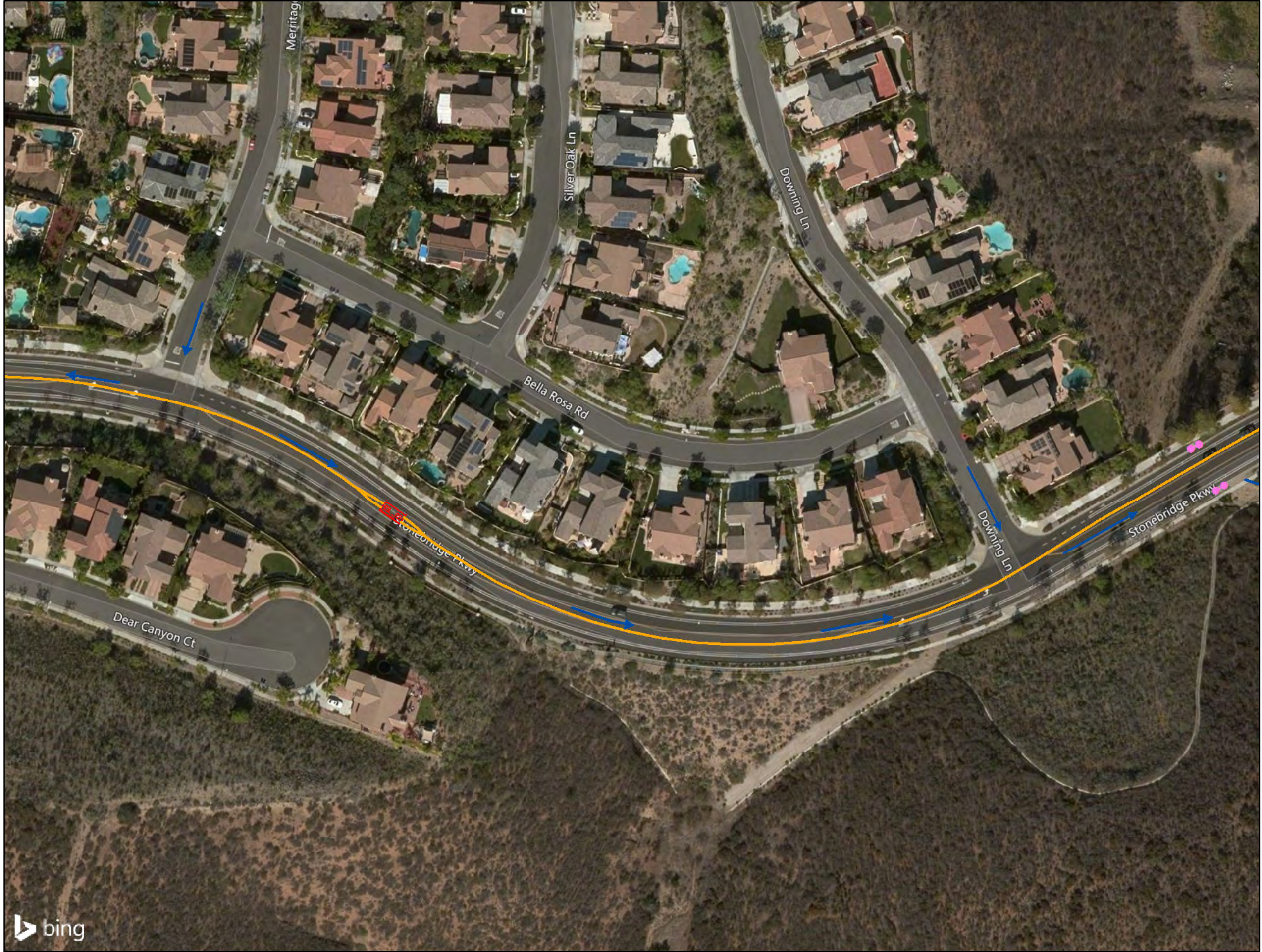

**Sycamore to Peñasquitos
230kV Transmission
Line Project
SWPPP Detail Map
Sheet 6 of 68**

DRAFT

-  Tracking Control
 -  Flow Direction
 -  Silt Fence
 -  Fiber Roll
 -  Storm Drain Inlet Protection
 -  Streams & Rivers
- Project Features**
-  Entrance Point
 -  Project Overhead TL
 -  Project Underground TL
 -  Access Road
 -  Underground Vault
 -  Potential Staging Yards
 -  Temporary Work Area
 -  Permanent Impact

Notes:
Locations of perimeter control BMPs are not to scale. BMP locations are conceptual in nature and must be field-verified prior to construction. Protect all inlets where applicable. Staging yards may be active during any time of construction.

SDG&E is providing this map with the understanding that the map is not survey grade. Certain technology used under license from AT&T Intellectual Property I, L.P. Copyright ©1998 – 2007 AT&T Intellectual Property 1, L.P. All Rights Reserved.

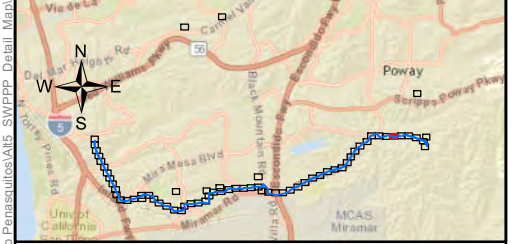

Service Layer Credits: Sources: Esri, HERE, DeLorme, USGS, Intermap, INCREMENT P, NRCan, Esri Japan, METI, Esri China (Hong Kong), Esri Korea, Esri (Thailand), MapmyIndia, NGCC, © OpenStreetMap contributors, and the GIS User Community © 2016 Microsoft Corporation © 2010 NAVTEQ © AND



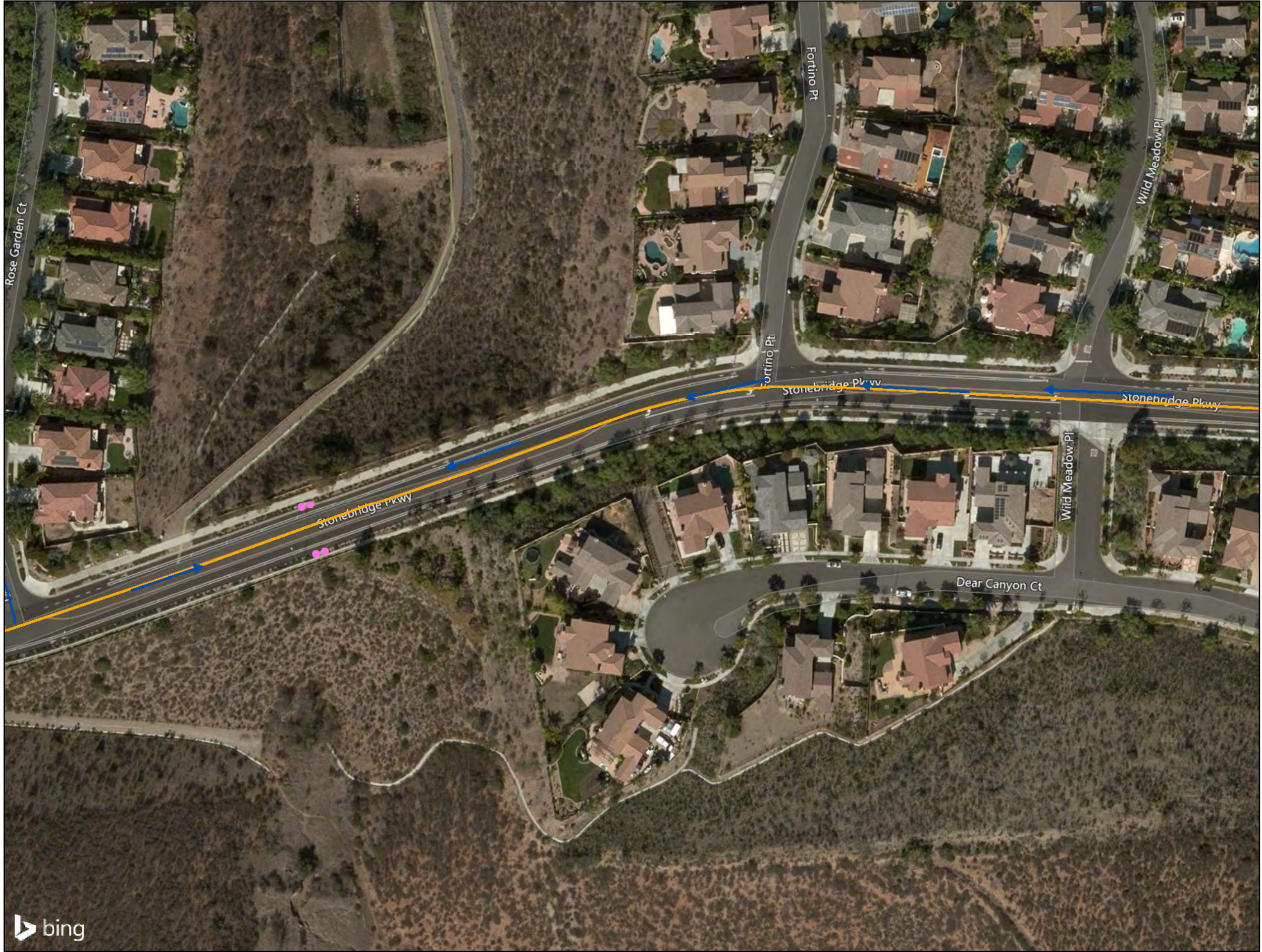

**Sycamore to Peñasquitos
230kV Transmission
Line Project
SWPPP Detail Map
Sheet 7 of 68**

DRAFT

-  Tracking Control
-  Flow Direction
-  Silt Fence
-  Fiber Roll
-  Storm Drain Inlet Protection
-  Streams & Rivers

- Project Features**
-  Entrance Point
-  Project Overhead TL
-  Project Underground TL
-  Access Road
-  Underground Vault
-  Potential Staging Yards
-  Temporary Work Area
-  Permanent Impact

Notes:
Locations of perimeter control BMPs are not to scale. BMP locations are conceptual in nature and must be field-verified prior to construction. Protect all inlets where applicable. Staging yards may be active during any time of construction.

SDG&E is providing this map with the understanding that the map is not survey grade. Certain technology used under license from AT&T Intellectual Property I, L.P. Copyright ©1998 – 2007 AT&T Intellectual Property 1, L.P. All Rights Reserved.

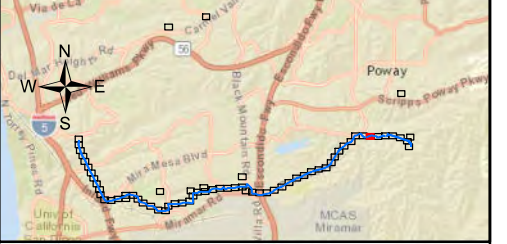
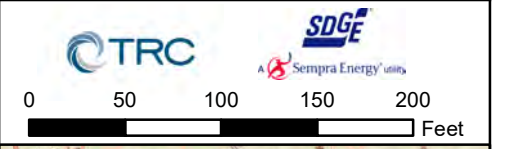

Service Layer Credits: Sources: Esri, HERE, DeLorme, USGS, Intermap, INCREMENT P, NRCan, Esri Japan, METI, Esri China (Hong Kong), Esri Korea, Esri (Thailand), MapmyIndia, NGCC, © OpenStreetMap contributors, and the GIS User Community © 2016 Microsoft Corporation © 2010 NAVTEQ © AND



**Sycamore to Peñasquitos
230kV Transmission
Line Project
SWPPP Detail Map
Sheet 8 of 68**

DRAFT

-  Tracking Control
 -  Flow Direction
 -  Silt Fence
 -  Fiber Roll
 -  Storm Drain Inlet Protection
 -  Streams & Rivers
- Project Features**
-  Entrance Point
 -  Project Overhead TL
 -  Project Underground TL
 -  Access Road
 -  Underground Vault
 -  Potential Staging Yards
 -  Temporary Work Area
 -  Permanent Impact

Notes:
Locations of perimeter control BMPs are not to scale. BMP locations are conceptual in nature and must be field-verified prior to construction. Protect all inlets where applicable. Staging yards may be active during any time of construction.

SDG&E is providing this map with the understanding that the map is not survey grade. Certain technology used under license from AT&T Intellectual Property I, L.P. Copyright ©1998 – 2007 AT&T Intellectual Property 1, L.P. All Rights Reserved.

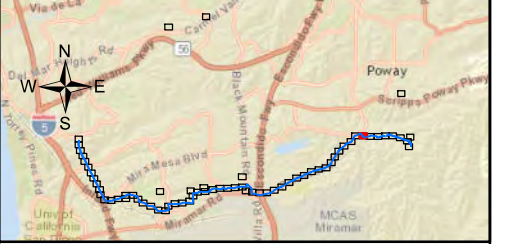
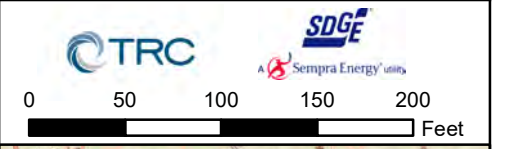

Service Layer Credits: Sources: Esri, HERE, DeLorme, USGS, Intermap, INCREMENT P, NRCan, Esri Japan, METI, Esri China (Hong Kong), Esri Korea, Esri (Thailand), MapmyIndia, NGCC, © OpenStreetMap contributors, and the GIS User Community © 2016 Microsoft Corporation © 2010 NAVTEQ © AND





**Sycamore to Peñasquitos
230kV Transmission
Line Project
SWPPP Detail Map
Sheet 9 of 68**

DRAFT

-  Tracking Control
 -  Flow Direction
 -  Silt Fence
 -  Fiber Roll
 -  Storm Drain Inlet Protection
 -  Streams & Rivers
- Project Features**
-  Entrance Point
 -  Project Overhead TL
 -  Project Underground TL
 -  Access Road
 -  Underground Vault
 -  Potential Staging Yards
 -  Temporary Work Area
 -  Permanent Impact

Notes:
Locations of perimeter control BMPs are not to scale. BMP locations are conceptual in nature and must be field-verified prior to construction. Protect all inlets where applicable. Staging yards may be active during any time of construction.

SDG&E is providing this map with the understanding that the map is not survey grade. Certain technology used under license from AT&T Intellectual Property I, L.P. Copyright ©1998 – 2007 AT&T Intellectual Property 1, L.P. All Rights Reserved.

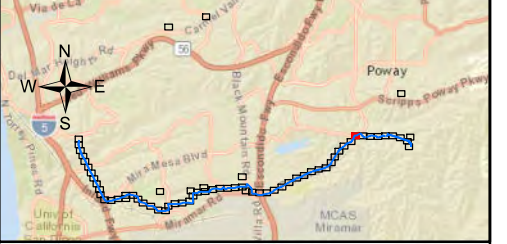
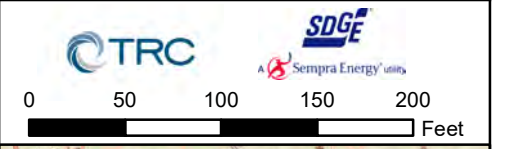

Service Layer Credits: Sources: Esri, HERE, DeLorme, USGS, Intermap, INCREMENT P, NRCan, Esri Japan, METI, Esri China (Hong Kong), Esri Korea, Esri (Thailand), MapmyIndia, NGCC, © OpenStreetMap contributors, and the GIS User Community
© 2016 Microsoft Corporation © 2010 NAVTEQ © AND



**Sycamore to Peñasquitos
230kV Transmission
Line Project
SWPPP Detail Map
Sheet 10 of 68**

DRAFT

-  Tracking Control
-  Flow Direction
-  Silt Fence
-  Fiber Roll
-  Storm Drain Inlet Protection
-  Streams & Rivers

- Project Features**
-  Entrance Point
-  Project Overhead TL
-  Project Underground TL
-  Access Road
-  Underground Vault
-  Potential Staging Yards
-  Temporary Work Area
-  Permanent Impact

Notes:
Locations of perimeter control BMPs are not to scale. BMP locations are conceptual in nature and must be field-verified prior to construction. Protect all inlets where applicable. Staging yards may be active during any time of construction.

SDG&E is providing this map with the understanding that the map is not survey grade. Certain technology used under license from AT&T Intellectual Property I, L.P. Copyright ©1998 – 2007 AT&T Intellectual Property 1, L.P. All Rights Reserved.

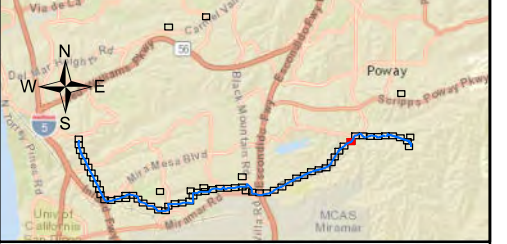
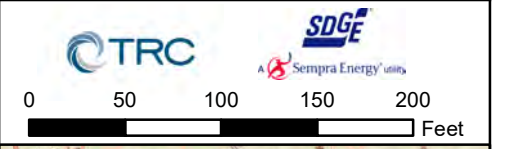

Service Layer Credits: Sources: Esri, HERE, DeLorme, USGS, Intermap, INCREMENT P, NRCan, Esri Japan, METI, Esri China (Hong Kong), Esri Korea, Esri (Thailand), MapmyIndia, NGCC, © OpenStreetMap contributors, and the GIS User Community © 2016 Microsoft Corporation © 2010 NAVTEQ © AND





**Sycamore to Peñasquitos
230kV Transmission
Line Project
SWPPP Detail Map
Sheet 11 of 68**

- Tracking Control** **DRAFT**
- Flow Direction
 - Silt Fence
 - Fiber Roll
 - Storm Drain Inlet Protection
 - Streams & Rivers
- Project Features**
- Entrance Point
 - Project Overhead TL
 - Project Underground TL
 - Access Road
 - Underground Vault
 - Potential Staging Yards
 - Temporary Work Area
 - Permanent Impact

Notes:
Locations of perimeter control BMPs are not to scale. BMP locations are conceptual in nature and must be field-verified prior to construction. Protect all inlets where applicable. Staging yards may be active during any time of construction.

SDG&E is providing this map with the understanding that the map is not survey grade. Certain technology used under license from AT&T Intellectual Property I, L.P. Copyright ©1998 – 2007 AT&T Intellectual Property 1, L.P. All Rights Reserved.

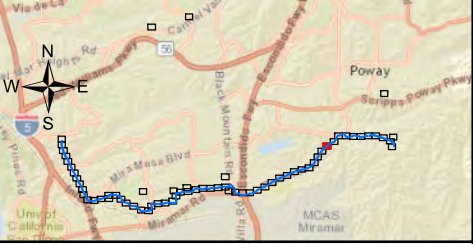
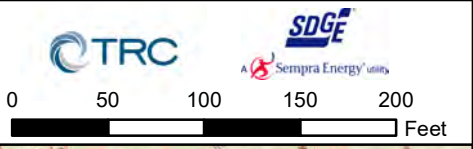

Service Layer Credits: Sources: Esri, HERE, DeLorme, USGS, Intermap, INCREMENT P, NRCan, Esri Japan, METI, Esri China (Hong Kong), Esri Korea, Esri (Thailand), MapmyIndia, NGCC, © OpenStreetMap contributors, and the GIS User Community © 2016 Microsoft Corporation © 2010 NAVTEQ © AND



**Sycamore to Peñasquitos
230kV Transmission
Line Project
SWPPP Detail Map
Sheet 12 of 68**

- Tracking Control** **DRAFT**
- Tracking Control
 - Flow Direction
 - Silt Fence
 - Fiber Roll
 - Storm Drain Inlet Protection
 - Streams & Rivers
- Project Features**
- Entrance Point
 - Project Overhead TL
 - Project Underground TL
 - Access Road
 - Underground Vault
 - Potential Staging Yards
 - Temporary Work Area
 - Permanent Impact

Notes:
Locations of perimeter control BMPs are not to scale. BMP locations are conceptual in nature and must be field-verified prior to construction. Protect all inlets where applicable. Staging yards may be active during any time of construction.

SDG&E is providing this map with the understanding that the map is not survey grade. Certain technology used under license from AT&T Intellectual Property I, L.P. Copyright ©1998 – 2007 AT&T Intellectual Property 1, L.P. All Rights Reserved.

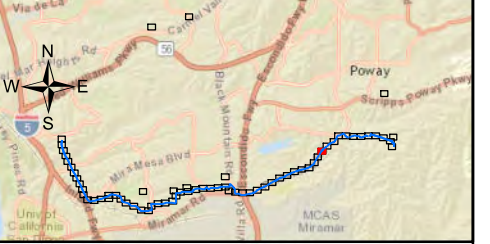
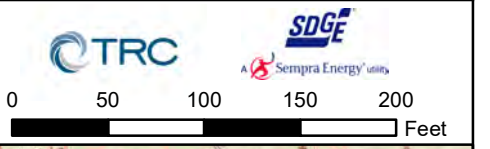

Service Layer Credits: Sources: Esri, HERE, DeLorme, USGS, Intermap, INCREMENT P, NRCan, Esri Japan, METI, Esri China (Hong Kong), Esri Korea, Esri (Thailand), MapmyIndia, NGCC, © OpenStreetMap contributors, and the GIS User Community © 2016 Microsoft Corporation © 2010 NAVTEQ © AND



**Sycamore to Peñasquitos
230kV Transmission
Line Project
SWPPP Detail Map
Sheet 13 of 68**

- DRAFT**
- Tracking Control
 - Flow Direction
 - Silt Fence
 - Fiber Roll
 - Storm Drain Inlet Protection
 - Streams & Rivers
- Project Features**
- Entrance Point
 - Project Overhead TL
 - Project Underground TL
 - Access Road
 - Underground Vault
 - Potential Staging Yards
 - Temporary Work Area
 - Permanent Impact

Notes:
Locations of perimeter control BMPs are not to scale. BMP locations are conceptual in nature and must be field-verified prior to construction. Protect all inlets where applicable. Staging yards may be active during any time of construction.

SDG&E is providing this map with the understanding that the map is not survey grade. Certain technology used under license from AT&T Intellectual Property I, L.P. Copyright ©1998 – 2007 AT&T Intellectual Property 1, L.P. All Rights Reserved.

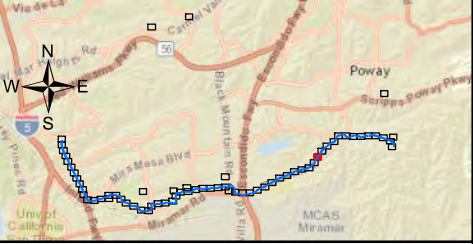
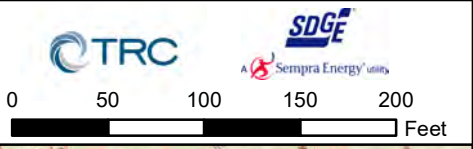

Service Layer Credits: Sources: Esri, HERE, DeLorme, USGS, Intermap, INCREMENT P, NRCan, Esri Japan, METI, Esri China (Hong Kong), Esri Korea, Esri (Thailand), MapmyIndia, NGCC, © OpenStreetMap contributors, and the GIS User Community © 2016 Microsoft Corporation © 2010 NAVTEQ © AND





**Sycamore to Peñasquitos
230kV Transmission
Line Project
SWPPP Detail Map
Sheet 14 of 68**

DRAFT

-  Tracking Control
 -  Flow Direction
 -  Silt Fence
 -  Fiber Roll
 -  Storm Drain Inlet Protection
 -  Streams & Rivers
- Project Features**
-  Entrance Point
 -  Project Overhead TL
 -  Project Underground TL
 -  Access Road
 -  Underground Vault
 -  Potential Staging Yards
 -  Temporary Work Area
 -  Permanent Impact

Notes:
Locations of perimeter control BMPs are not to scale. BMP locations are conceptual in nature and must be field-verified prior to construction. Protect all inlets where applicable. Staging yards may be active during any time of construction.

SDG&E is providing this map with the understanding that the map is not survey grade. Certain technology used under license from AT&T Intellectual Property I, L.P. Copyright ©1998 – 2007 AT&T Intellectual Property 1, L.P. All Rights Reserved.

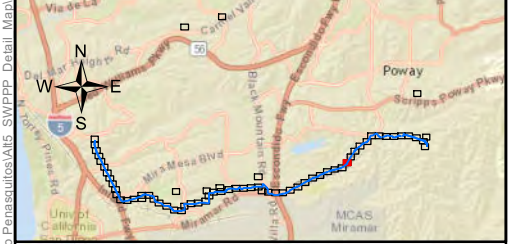

Service Layer Credits: Sources: Esri, HERE, DeLorme, USGS, Intermap, INCREMENT P, NRCan, Esri Japan, METI, Esri China (Hong Kong), Esri Korea, Esri (Thailand), MapmyIndia, NGCC, © OpenStreetMap contributors, and the GIS User Community © 2016 Microsoft Corporation © 2010 NAVTEQ © AND





**Sycamore to Peñasquitos
230kV Transmission
Line Project
SWPPP Detail Map
Sheet 15 of 68**

DRAFT

-  Tracking Control
 -  Flow Direction
 -  Silt Fence
 -  Fiber Roll
 -  Storm Drain Inlet Protection
 -  Streams & Rivers
- Project Features**
-  Entrance Point
 -  Project Overhead TL
 -  Project Underground TL
 -  Access Road
 -  Underground Vault
 -  Potential Staging Yards
 -  Temporary Work Area
 -  Permanent Impact

Notes:
Locations of perimeter control BMPs are not to scale. BMP locations are conceptual in nature and must be field-verified prior to construction. Protect all inlets where applicable. Staging yards may be active during any time of construction.

SDG&E is providing this map with the understanding that the map is not survey grade. Certain technology used under license from AT&T Intellectual Property I, L.P. Copyright ©1998 – 2007 AT&T Intellectual Property 1, L.P. All Rights Reserved.

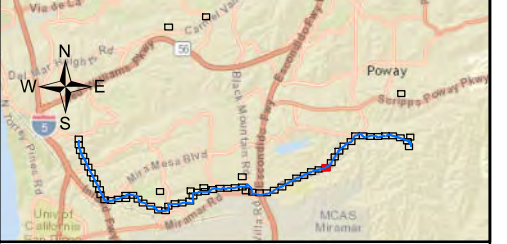
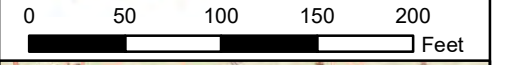

Service Layer Credits: Sources: Esri, HERE, DeLorme, USGS, Intermap, INCREMENT P, NRCan, Esri Japan, METI, Esri China (Hong Kong), Esri Korea, Esri (Thailand), MapmyIndia, NGCC, © OpenStreetMap contributors, and the GIS User Community © 2016 Microsoft Corporation © 2010 NAVTEQ © AND

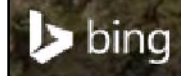



**Sycamore to Peñasquitos
230kV Transmission
Line Project
SWPPP Detail Map
Sheet 16 of 68**

DRAFT

-  Tracking Control
-  Flow Direction
-  Silt Fence
-  Fiber Roll
-  Storm Drain Inlet Protection
-  Streams & Rivers
- Project Features**
-  Entrance Point
-  Project Overhead TL
-  Project Underground TL
-  Access Road
-  Underground Vault
-  Potential Staging Yards
-  Temporary Work Area
-  Permanent Impact

Notes:
Locations of perimeter control BMPs are not to scale. BMP locations are conceptual in nature and must be field-verified prior to construction. Protect all inlets where applicable. Staging yards may be active during any time of construction.

SDG&E is providing this map with the understanding that the map is not survey grade. Certain technology used under license from AT&T Intellectual Property I, L.P. Copyright ©1998 – 2007 AT&T Intellectual Property 1, L.P. All Rights Reserved.

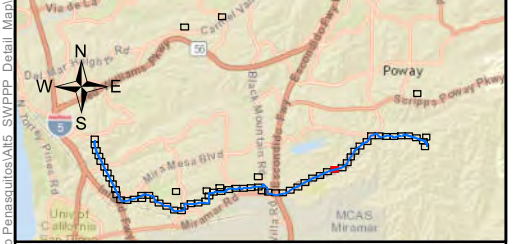
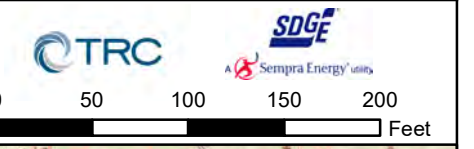

Service Layer Credits: Sources: Esri, HERE, DeLorme, USGS, Intermap, INCREMENT P, NRCan, Esri Japan, METI, Esri China (Hong Kong), Esri Korea, Esri (Thailand), MapmyIndia, NGCC, © OpenStreetMap contributors, and the GIS User Community © 2016 Microsoft Corporation © 2010 NAVTEQ © AND





**Sycamore to Peñasquitos
230kV Transmission
Line Project
SWPPP Detail Map
Sheet 17 of 68**

DRAFT

-  Tracking Control
 -  Flow Direction
 -  Silt Fence
 -  Fiber Roll
 -  Storm Drain Inlet Protection
 -  Streams & Rivers
- Project Features**
-  Entrance Point
 -  Project Overhead TL
 -  Project Underground TL
 -  Access Road
 -  Underground Vault
 -  Potential Staging Yards
 -  Temporary Work Area
 -  Permanent Impact

Notes:
Locations of perimeter control BMPs are not to scale. BMP locations are conceptual in nature and must be field-verified prior to construction. Protect all inlets where applicable. Staging yards may be active during any time of construction.

SDG&E is providing this map with the understanding that the map is not survey grade. Certain technology used under license from AT&T Intellectual Property I, L.P. Copyright ©1998 – 2007 AT&T Intellectual Property 1, L.P. All Rights Reserved.

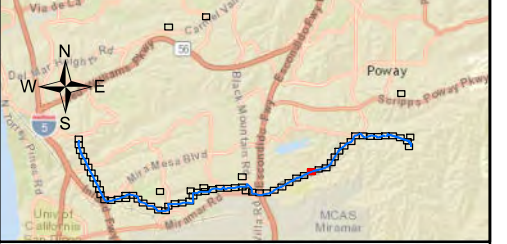
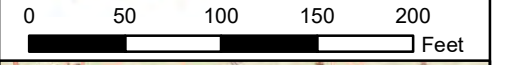















Service Layer Credits: Sources: Esri, HERE, DeLorme, USGS, Intermap, INCREMENT P, NRCan, Esri Japan, METI, Esri China (Hong Kong), Esri Korea, Esri (Thailand), MapmyIndia, NGCC, © OpenStreetMap contributors, and the GIS User Community © 2016 Microsoft Corporation © 2010 NAVTEQ © AND



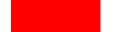

**Sycamore to Peñasquitos
230kV Transmission
Line Project
SWPPP Detail Map
Sheet 18 of 68**

DRAFT

-  Tracking Control
-  Flow Direction
-  Silt Fence
-  Fiber Roll
-  Storm Drain Inlet Protection
-  Streams & Rivers
- Project Features**
-  Entrance Point
-  Project Overhead TL
-  Project Underground TL
-  Access Road
-  Underground Vault
-  Potential Staging Yards
-  Temporary Work Area
-  Permanent Impact

Notes:
Locations of perimeter control BMPs are not to scale. BMP locations are conceptual in nature and must be field-verified prior to construction. Protect all inlets where applicable. Staging yards may be active during any time of construction.

SDG&E is providing this map with the understanding that the map is not survey grade. Certain technology used under license from AT&T Intellectual Property I, L.P. Copyright ©1998 – 2007 AT&T Intellectual Property 1, L.P. All Rights Reserved.

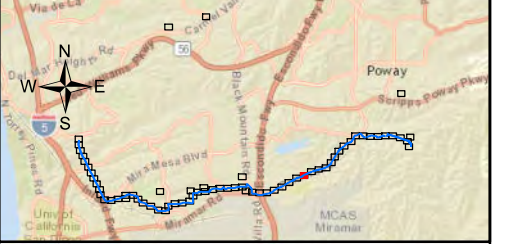
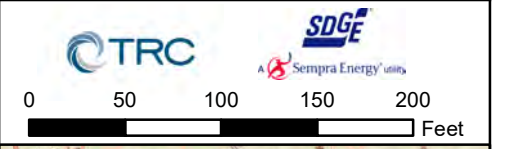

Service Layer Credits: Sources: Esri, HERE, DeLorme, USGS, Intermap, INCREMENT P, NRCan, Esri Japan, METI, Esri China (Hong Kong), Esri Korea, Esri (Thailand), MapmyIndia, NGCC, © OpenStreetMap contributors, and the GIS User Community © 2016 Microsoft Corporation © 2010 NAVTEQ © AND





**Sycamore to Peñasquitos
230kV Transmission
Line Project
SWPPP Detail Map
Sheet 19 of 68**

- DRAFT**
- Tracking Control
 - Flow Direction
 - Silt Fence
 - Fiber Roll
 - Storm Drain Inlet Protection
 - Streams & Rivers
- Project Features**
- Entrance Point
 - Project Overhead TL
 - Project Underground TL
 - Access Road
 - Underground Vault
 - Potential Staging Yards
 - Temporary Work Area
 - Permanent Impact

Notes:
Locations of perimeter control BMPs are not to scale. BMP locations are conceptual in nature and must be field-verified prior to construction. Protect all inlets where applicable. Staging yards may be active during any time of construction.

SDG&E is providing this map with the understanding that the map is not survey grade. Certain technology used under license from AT&T Intellectual Property I, L.P. Copyright ©1998 – 2007 AT&T Intellectual Property 1, L.P. All Rights Reserved.

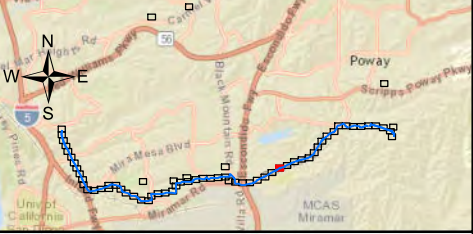
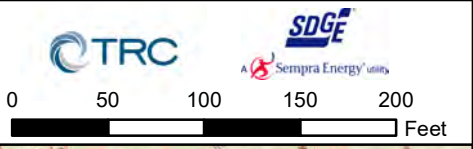















Service Layer Credits: Sources: Esri, HERE, DeLorme, USGS, Intermap, INCREMENT P, NRCan, Esri Japan, METI, Esri China (Hong Kong), Esri Korea, Esri (Thailand), MapmyIndia, NGCC, © OpenStreetMap contributors, and the GIS User Community © 2016 Microsoft Corporation © 2010 NAVTEQ © AND



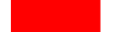

**Sycamore to Peñasquitos
230kV Transmission
Line Project
SWPPP Detail Map
Sheet 20 of 68**

DRAFT

-  Tracking Control
-  Flow Direction
-  Silt Fence
-  Fiber Roll
-  Storm Drain Inlet Protection
-  Streams & Rivers
- Project Features**
-  Entrance Point
-  Project Overhead TL
-  Project Underground TL
-  Access Road
-  Underground Vault
-  Potential Staging Yards
-  Temporary Work Area
-  Permanent Impact

Notes:
Locations of perimeter control BMPs are not to scale. BMP locations are conceptual in nature and must be field-verified prior to construction. Protect all inlets where applicable. Staging yards may be active during any time of construction.

SDG&E is providing this map with the understanding that the map is not survey grade. Certain technology used under license from AT&T Intellectual Property I, L.P. Copyright ©1998 – 2007 AT&T Intellectual Property 1, L.P. All Rights Reserved.

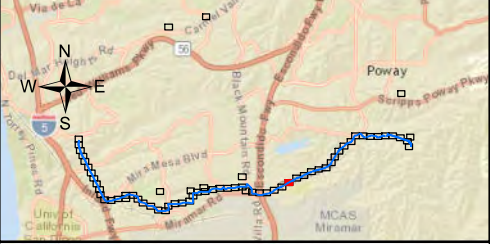
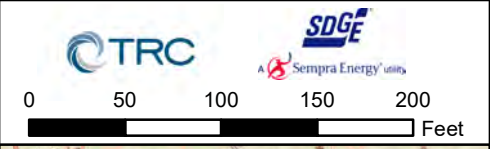















Service Layer Credits: Sources: Esri, HERE, DeLorme, USGS, Intermap, INCREMENT P, NRCan, Esri Japan, METI, Esri China (Hong Kong), Esri Korea, Esri (Thailand), MapmyIndia, NGCC, © OpenStreetMap contributors, and the GIS User Community © 2016 Microsoft Corporation © 2010 NAVTEQ © AND





**Sycamore to Peñasquitos
230kV Transmission
Line Project
SWPPP Detail Map
Sheet 21 of 68**

DRAFT

-  Tracking Control
-  Flow Direction
-  Silt Fence
-  Fiber Roll
-  Storm Drain Inlet Protection
-  Streams & Rivers
- Project Features**
-  Entrance Point
-  Project Overhead TL
-  Project Underground TL
-  Access Road
-  Underground Vault
-  Potential Staging Yards
-  Temporary Work Area
-  Permanent Impact

Notes:
Locations of perimeter control BMPs are not to scale. BMP locations are conceptual in nature and must be field-verified prior to construction. Protect all inlets where applicable. Staging yards may be active during any time of construction.

SDG&E is providing this map with the understanding that the map is not survey grade. Certain technology used under license from AT&T Intellectual Property I, L.P. Copyright ©1998 – 2007 AT&T Intellectual Property 1, L.P. All Rights Reserved.

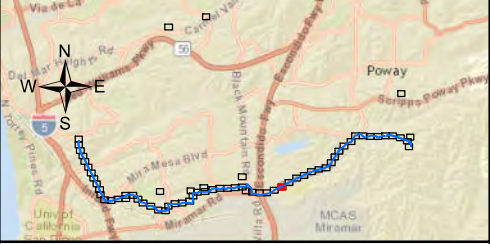
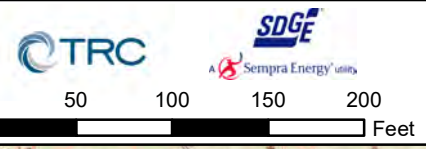

Service Layer Credits: Sources: Esri, HERE, DeLorme, USGS, Intermap, INCREMENT P, NRCan, Esri Japan, METI, Esri China (Hong Kong), Esri Korea, Esri (Thailand), MapmyIndia, NGCC, © OpenStreetMap contributors, and the GIS User Community © 2016 Microsoft Corporation © 2010 NAVTEQ © AND





**Sycamore to Peñasquitos
230kV Transmission
Line Project
SWPPP Detail Map
Sheet 22 of 68**

DRAFT

-  Tracking Control
-  Flow Direction
-  Silt Fence
-  Fiber Roll
-  Storm Drain Inlet Protection
-  Streams & Rivers
- Project Features**
-  Entrance Point
-  Project Overhead TL
-  Project Underground TL
-  Access Road
-  Underground Vault
-  Potential Staging Yards
-  Temporary Work Area
-  Permanent Impact

Notes:
Locations of perimeter control BMPs are not to scale. BMP locations are conceptual in nature and must be field-verified prior to construction. Protect all inlets where applicable. Staging yards may be active during any time of construction.

SDG&E is providing this map with the understanding that the map is not survey grade. Certain technology used under license from AT&T Intellectual Property I, L.P. Copyright ©1998 – 2007 AT&T Intellectual Property 1, L.P. All Rights Reserved.

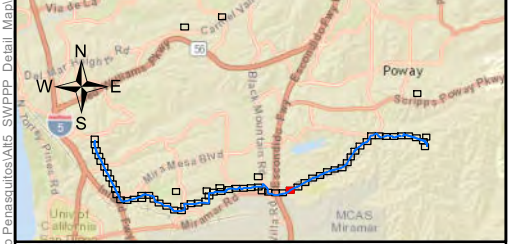
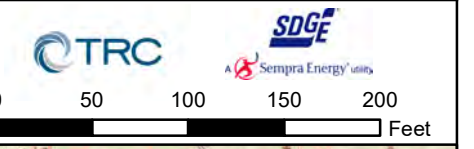









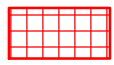





Service Layer Credits: Sources: Esri, HERE, DeLorme, USGS, Intermap, INCREMENT P, NRCan, Esri Japan, METI, Esri China (Hong Kong), Esri Korea, Esri (Thailand), MapmyIndia, NGCC, © OpenStreetMap contributors, and the GIS User Community © 2016 Microsoft Corporation © 2010 NAVTEQ © AND





**Sycamore to Peñasquitos
230kV Transmission
Line Project
SWPPP Detail Map
Sheet 23 of 68**

- DRAFT**
-  Tracking Control
 -  Flow Direction
 -  Silt Fence
 -  Fiber Roll
 -  Storm Drain Inlet Protection
 -  Streams & Rivers
- Project Features**
-  Entrance Point
 -  Project Overhead TL
 -  Project Underground TL
 -  Access Road
 -  Underground Vault
 -  Potential Staging Yards
 -  Temporary Work Area
 -  Permanent Impact

Notes:
Locations of perimeter control BMPs are not to scale. BMP locations are conceptual in nature and must be field-verified prior to construction. Protect all inlets where applicable. Staging yards may be active during any time of construction.

SDG&E is providing this map with the understanding that the map is not survey grade. Certain technology used under license from AT&T Intellectual Property I, L.P. Copyright ©1998 – 2007 AT&T Intellectual Property 1, L.P. All Rights Reserved.

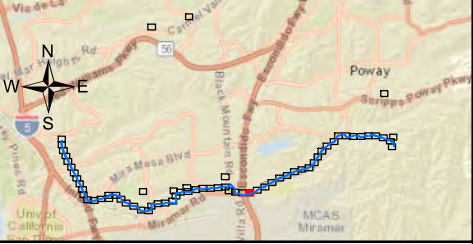
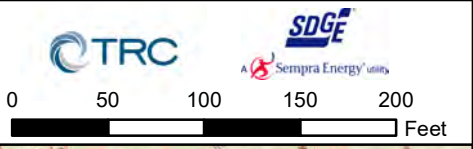

Service Layer Credits: Sources: Esri, HERE, DeLorme, USGS, Intermap, INCREMENT P, NRCan, Esri Japan, METI, Esri China (Hong Kong), Esri Korea, Esri (Thailand), MapmyIndia, NGCC, © OpenStreetMap contributors, and the GIS User Community © 2016 Microsoft Corporation © 2010 NAVTEQ © AND



**Sycamore to Peñasquitos
230kV Transmission
Line Project
SWPPP Detail Map
Sheet 24 of 68**

- DRAFT**
- Tracking Control
 - Flow Direction
 - Silt Fence
 - Fiber Roll
 - Storm Drain Inlet Protection
 - Streams & Rivers
- Project Features**
- Entrance Point
 - Project Overhead TL
 - Project Underground TL
 - Access Road
 - Underground Vault
 - Potential Staging Yards
 - Temporary Work Area
 - Permanent Impact

Notes:
Locations of perimeter control BMPs are not to scale. BMP locations are conceptual in nature and must be field-verified prior to construction. Protect all inlets where applicable. Staging yards may be active during any time of construction.

SDG&E is providing this map with the understanding that the map is not survey grade. Certain technology used under license from AT&T Intellectual Property I, L.P. Copyright ©1998 – 2007 AT&T Intellectual Property 1, L.P. All Rights Reserved.

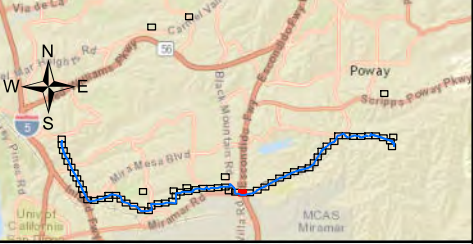
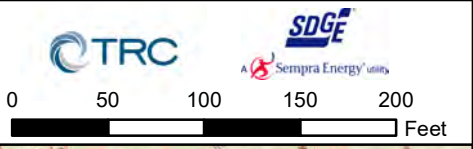

Service Layer Credits: Sources: Esri, HERE, DeLorme, USGS, Intermap, INCREMENT P, NRCan, Esri Japan, METI, Esri China (Hong Kong), Esri Korea, Esri (Thailand), MapmyIndia, NGCC, OpenStreetMap contributors, and the GIS User Community © 2016 Microsoft Corporation © 2010 NAVTEQ © AND

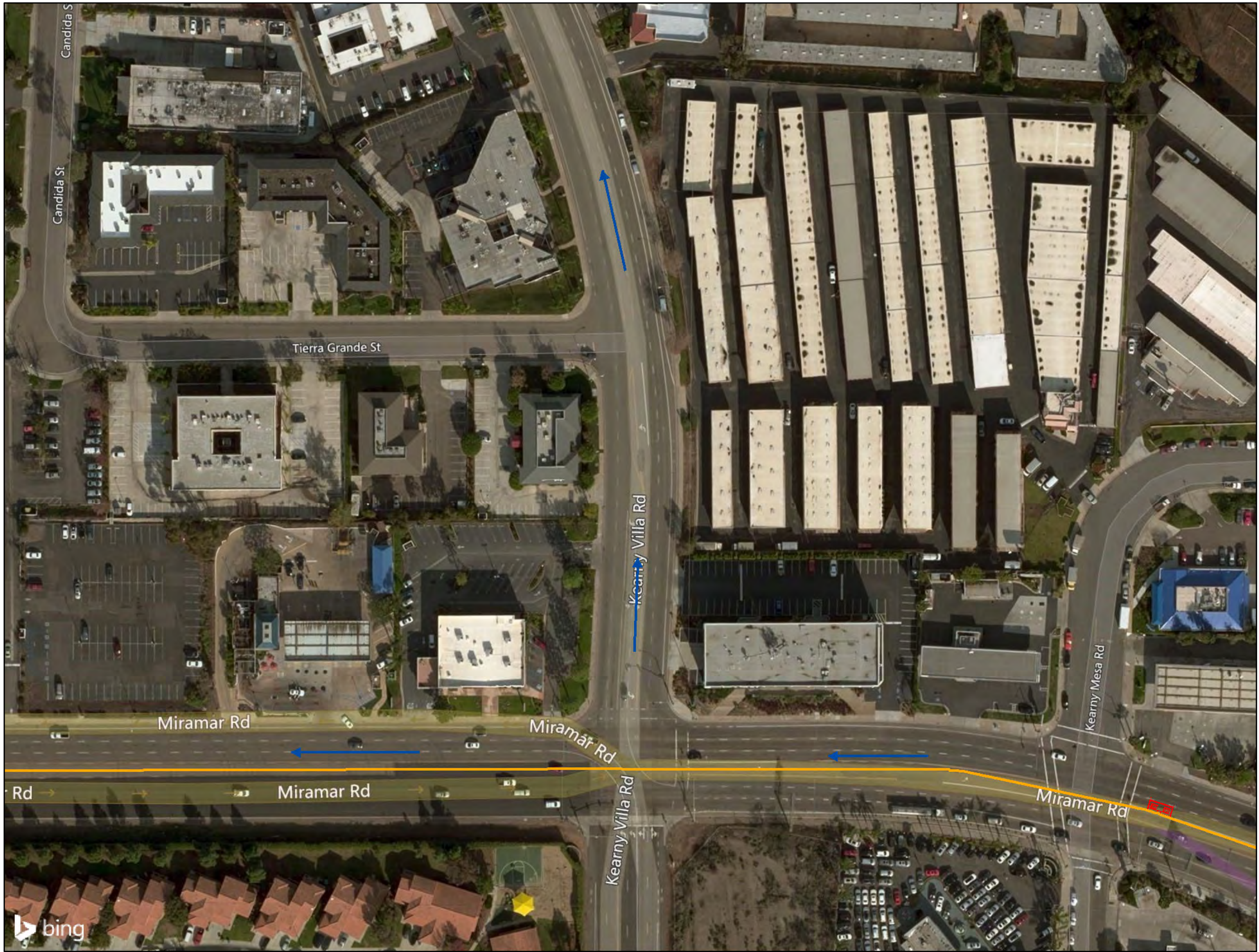

**Sycamore to Peñasquitos
230kV Transmission
Line Project
SWPPP Detail Map
Sheet 25 of 68**

DRAFT

-  Tracking Control
 -  Flow Direction
 -  Silt Fence
 -  Fiber Roll
 -  Storm Drain Inlet Protection
 -  Streams & Rivers
- Project Features**
-  Entrance Point
 -  Project Overhead TL
 -  Project Underground TL
 -  Access Road
 -  Underground Vault
 -  Potential Staging Yards
 -  Temporary Work Area
 -  Permanent Impact

Notes:
Locations of perimeter control BMPs are not to scale. BMP locations are conceptual in nature and must be field-verified prior to construction. Protect all inlets where applicable. Staging yards may be active during any time of construction.

SDG&E is providing this map with the understanding that the map is not survey grade. Certain technology used under license from AT&T Intellectual Property I, L.P. Copyright ©1998 – 2007 AT&T Intellectual Property 1, L.P. All Rights Reserved.

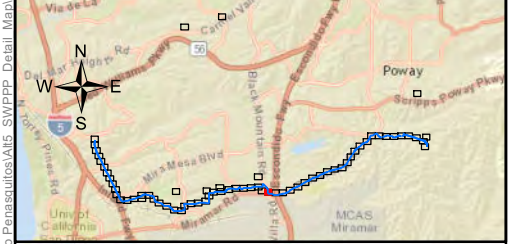
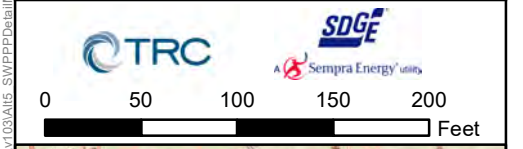

Service Layer Credits: Sources: Esri, HERE, DeLorme, USGS, Intermap, INCREMENT P, NRCan, Esri Japan, METI, Esri China (Hong Kong), Esri Korea, Esri (Thailand), MapmyIndia, NGCC, © OpenStreetMap contributors, and the GIS User Community © 2016 Microsoft Corporation © 2010 NAVTEQ © AND

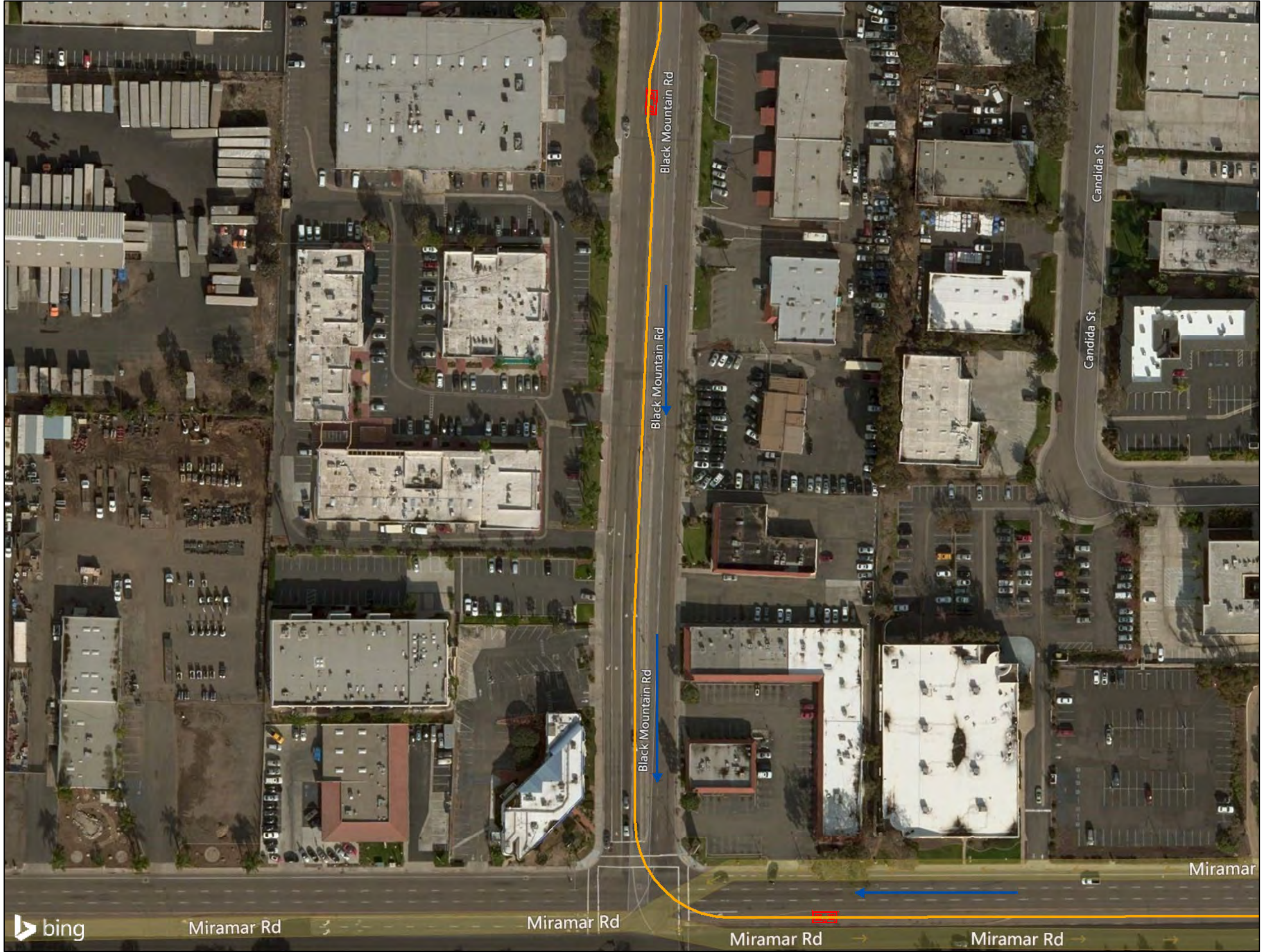

**Sycamore to Peñasquitos
230kV Transmission
Line Project
SWPPP Detail Map
Sheet 26 of 68**

DRAFT

-  Tracking Control
 -  Flow Direction
 -  Silt Fence
 -  Fiber Roll
 -  Storm Drain Inlet Protection
 -  Streams & Rivers
- Project Features**
-  Entrance Point
 -  Project Overhead TL
 -  Project Underground TL
 -  Access Road
 -  Underground Vault
 -  Potential Staging Yards
 -  Temporary Work Area
 -  Permanent Impact

Notes:
Locations of perimeter control BMPs are not to scale. BMP locations are conceptual in nature and must be field-verified prior to construction. Protect all inlets where applicable. Staging yards may be active during any time of construction.

SDG&E is providing this map with the understanding that the map is not survey grade. Certain technology used under license from AT&T Intellectual Property I, L.P. Copyright ©1998 – 2007 AT&T Intellectual Property 1, L.P. All Rights Reserved.

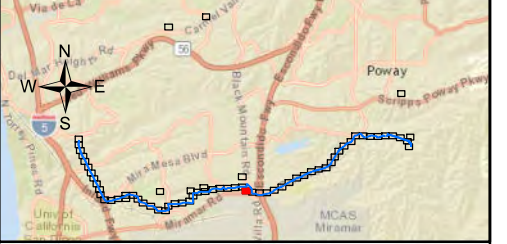
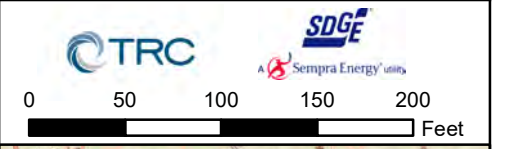



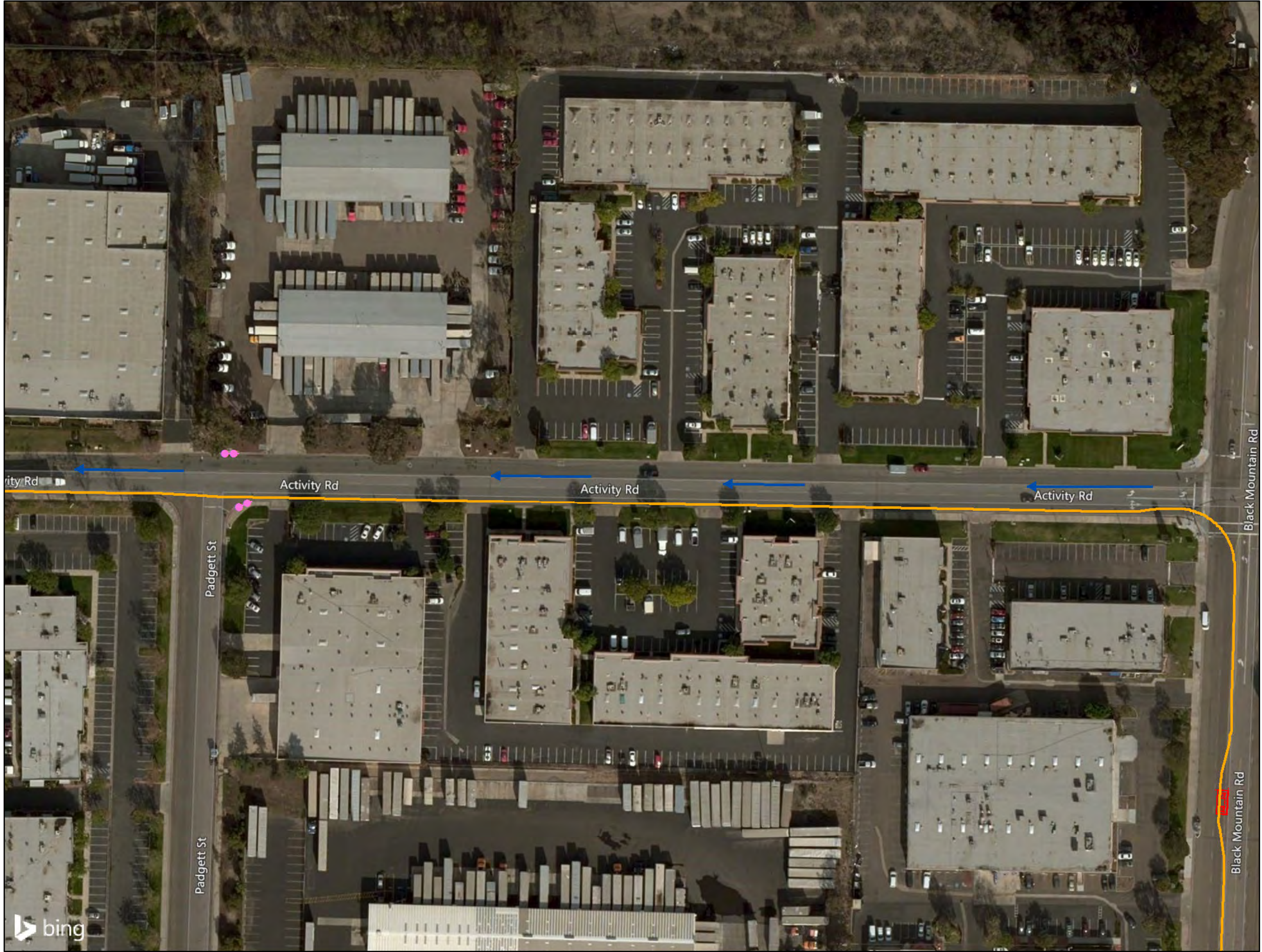











Service Layer Credits: Sources: Esri, HERE, DeLorme, USGS, Intermap, INCREMENT P, NRCan, Esri Japan, METI, Esri China (Hong Kong), Esri Korea, Esri (Thailand), MapmyIndia, NGCC, OpenStreetMap contributors, and the GIS User Community © 2016 Microsoft Corporation © 2010 NAVTEQ © AND



**Sycamore to Peñasquitos
230kV Transmission
Line Project
SWPPP Detail Map
Sheet 27 of 68**

DRAFT

-  Tracking Control
 -  Flow Direction
 -  Silt Fence
 -  Fiber Roll
 -  Storm Drain Inlet Protection
 -  Streams & Rivers
- Project Features**
-  Entrance Point
 -  Project Overhead TL
 -  Project Underground TL
 -  Access Road
 -  Underground Vault
 -  Potential Staging Yards
 -  Temporary Work Area
 -  Permanent Impact

Notes:
Locations of perimeter control BMPs are not to scale. BMP locations are conceptual in nature and must be field-verified prior to construction. Protect all inlets where applicable. Staging yards may be active during any time of construction.

SDG&E is providing this map with the understanding that the map is not survey grade. Certain technology used under license from AT&T Intellectual Property I, L.P. Copyright ©1998 – 2007 AT&T Intellectual Property 1, L.P. All Rights Reserved.

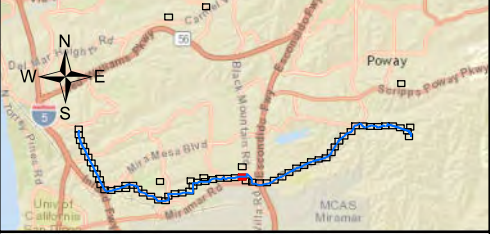
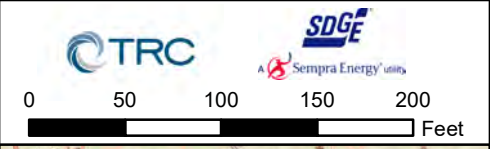







Service Layer Credits: Sources: Esri, HERE, DeLorme, USGS, Intermap, INCREMENT P, NRCan, Esri Japan, METI, Esri China (Hong Kong), Esri Korea, Esri (Thailand), MapmyIndia, NGCC, © OpenStreetMap contributors, and the GIS User Community © 2016 Microsoft Corporation © 2010 NAVTEQ © AND











**Sycamore to Peñasquitos
230kV Transmission
Line Project
SWPPP Detail Map
Sheet 28 of 68**

DRAFT

-  Tracking Control
-  Flow Direction
-  Silt Fence
-  Fiber Roll
-  Storm Drain Inlet Protection
-  Streams & Rivers

Project Features

-  Entrance Point
-  Project Overhead TL
-  Project Underground TL
-  Access Road
-  Underground Vault
-  Potential Staging Yards
-  Temporary Work Area
-  Permanent Impact

Notes:
Locations of perimeter control BMPs are not to scale. BMP locations are conceptual in nature and must be field-verified prior to construction. Protect all inlets where applicable. Staging yards may be active during any time of construction.

SDG&E is providing this map with the understanding that the map is not survey grade. Certain technology used under license from AT&T Intellectual Property I, L.P. Copyright ©1998 – 2007 AT&T Intellectual Property 1, L.P. All Rights Reserved.

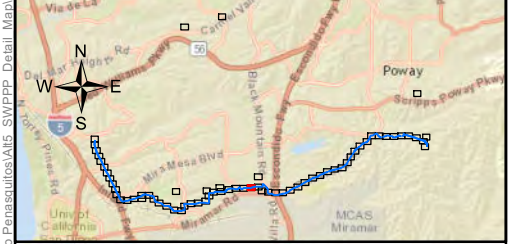

Service Layer Credits: Sources: Esri, HERE, DeLorme, USGS, Intermap, INCREMENT P, NRCan, Esri Japan, METI, Esri China (Hong Kong), Esri Korea, Esri (Thailand), MapmyIndia, NGCC, © OpenStreetMap contributors, and the GIS User Community © 2016 Microsoft Corporation © 2010 NAVTEQ © AND

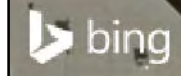

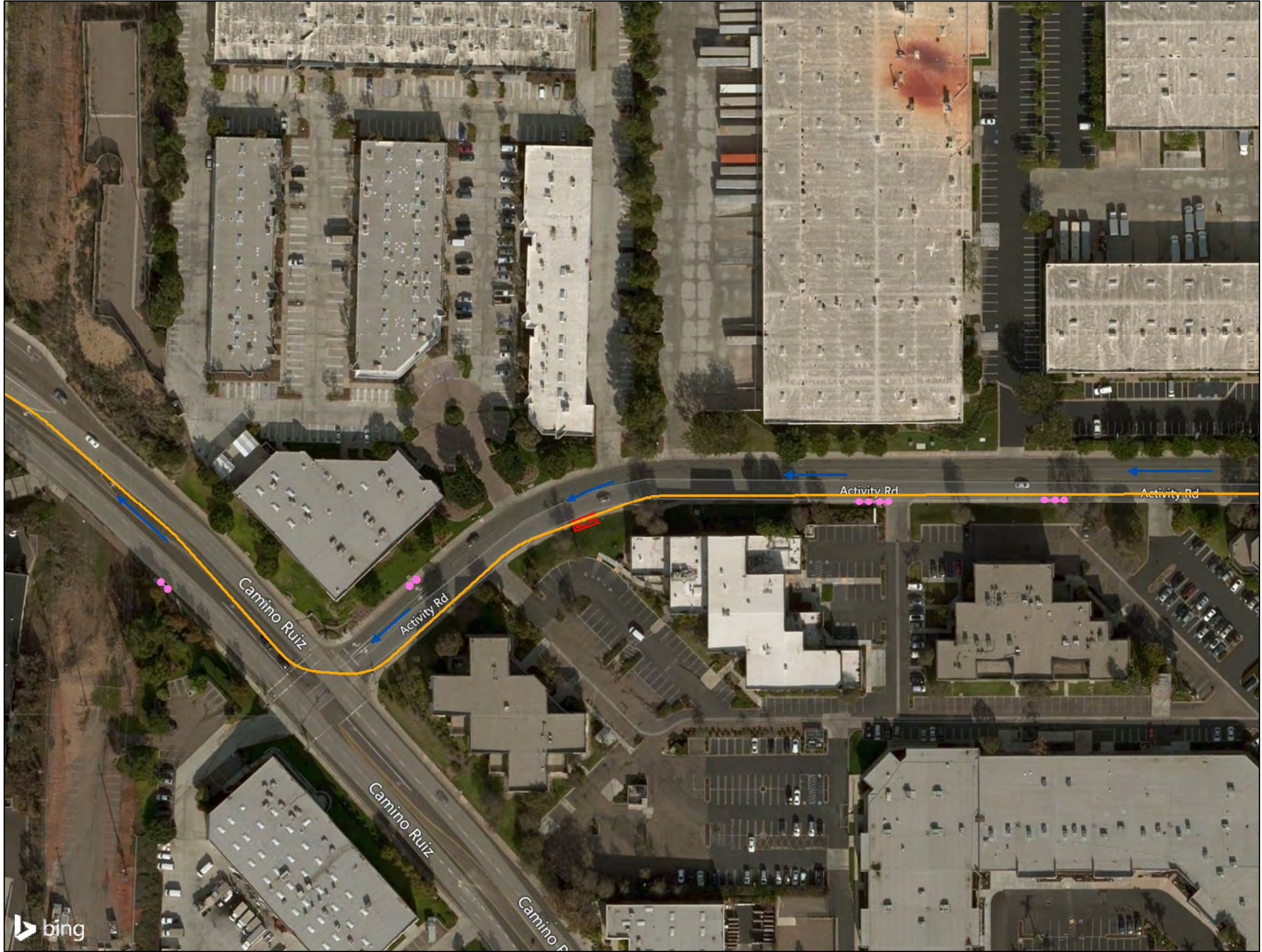

**Sycamore to Peñasquitos
230kV Transmission
Line Project
SWPPP Detail Map
Sheet 29 of 68**

DRAFT

-  Tracking Control
 -  Flow Direction
 -  Silt Fence
 -  Fiber Roll
 -  Storm Drain Inlet Protection
 -  Streams & Rivers
- Project Features**
-  Entrance Point
 -  Project Overhead TL
 -  Project Underground TL
 -  Access Road
 -  Underground Vault
 -  Potential Staging Yards
 -  Temporary Work Area
 -  Permanent Impact

Notes:
Locations of perimeter control BMPs are not to scale. BMP locations are conceptual in nature and must be field-verified prior to construction. Protect all inlets where applicable. Staging yards may be active during any time of construction.

SDG&E is providing this map with the understanding that the map is not survey grade. Certain technology used under license from AT&T Intellectual Property I, L.P. Copyright ©1998 – 2007 AT&T Intellectual Property 1, L.P. All Rights Reserved.

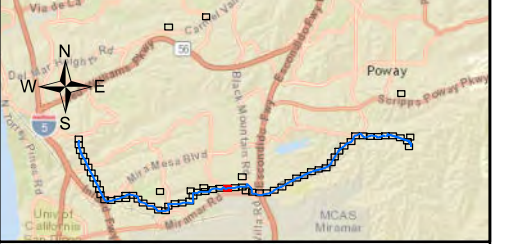
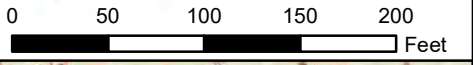

Service Layer Credits: Sources: Esri, HERE, DeLorme, USGS, Intermap, INCREMENT P, NRCan, Esri Japan, METI, Esri China (Hong Kong), Esri Korea, Esri (Thailand), MapmyIndia, NGCC, OpenStreetMap contributors, and the GIS User Community © 2016 Microsoft Corporation © 2010 NAVTEQ © AND





**Sycamore to Peñasquitos
230kV Transmission
Line Project
SWPPP Detail Map
Sheet 30 of 68**

DRAFT

-  Tracking Control
 -  Flow Direction
 -  Silt Fence
 -  Fiber Roll
 -  Storm Drain Inlet Protection
 -  Streams & Rivers
- Project Features**
-  Entrance Point
 -  Project Overhead TL
 -  Project Underground TL
 -  Access Road
 -  Underground Vault
 -  Potential Staging Yards
 -  Temporary Work Area
 -  Permanent Impact

Notes:
Locations of perimeter control BMPs are not to scale. BMP locations are conceptual in nature and must be field-verified prior to construction. Protect all inlets where applicable. Staging yards may be active during any time of construction.

SDG&E is providing this map with the understanding that the map is not survey grade. Certain technology used under license from AT&T Intellectual Property I, L.P. Copyright ©1998 – 2007 AT&T Intellectual Property I, L.P. All Rights Reserved.

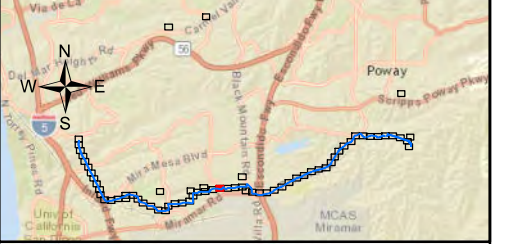
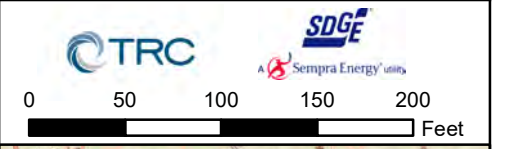

Service Layer Credits: Sources: Esri, HERE, DeLorme, USGS, Intermap, INCREMENT P, NRCan, Esri Japan, METI, Esri China (Hong Kong), Esri Korea, Esri (Thailand), MapmyIndia, NGCC, © OpenStreetMap contributors, and the GIS User Community © 2016 Microsoft Corporation © 2010 NAVTEQ © AND





**Sycamore to Peñasquitos
230kV Transmission
Line Project
SWPPP Detail Map
Sheet 31 of 68**

DRAFT

-  Tracking Control
 -  Flow Direction
 -  Silt Fence
 -  Fiber Roll
 -  Storm Drain Inlet Protection
 -  Streams & Rivers
- Project Features**
-  Entrance Point
 -  Project Overhead TL
 -  Project Underground TL
 -  Access Road
 -  Underground Vault
 -  Potential Staging Yards
 -  Temporary Work Area
 -  Permanent Impact

Notes:
Locations of perimeter control BMPs are not to scale. BMP locations are conceptual in nature and must be field-verified prior to construction. Protect all inlets where applicable. Staging yards may be active during any time of construction.

SDG&E is providing this map with the understanding that the map is not survey grade. Certain technology used under license from AT&T Intellectual Property I, L.P. Copyright ©1998 – 2007 AT&T Intellectual Property 1, L.P. All Rights Reserved.

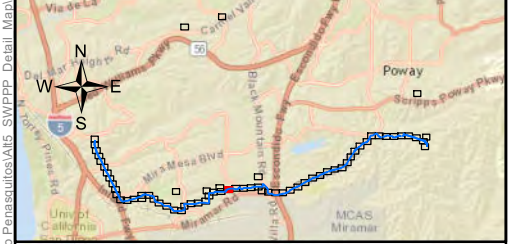
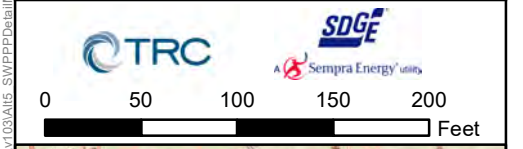

Service Layer Credits: Sources: Esri, HERE, DeLorme, USGS, Intermap, INCREMENT P, NRCan, Esri Japan, METI, Esri China (Hong Kong), Esri Korea, Esri (Thailand), MapmyIndia, NGCC, © OpenStreetMap contributors, and the GIS User Community © 2016 Microsoft Corporation © 2010 NAVTEQ © AND

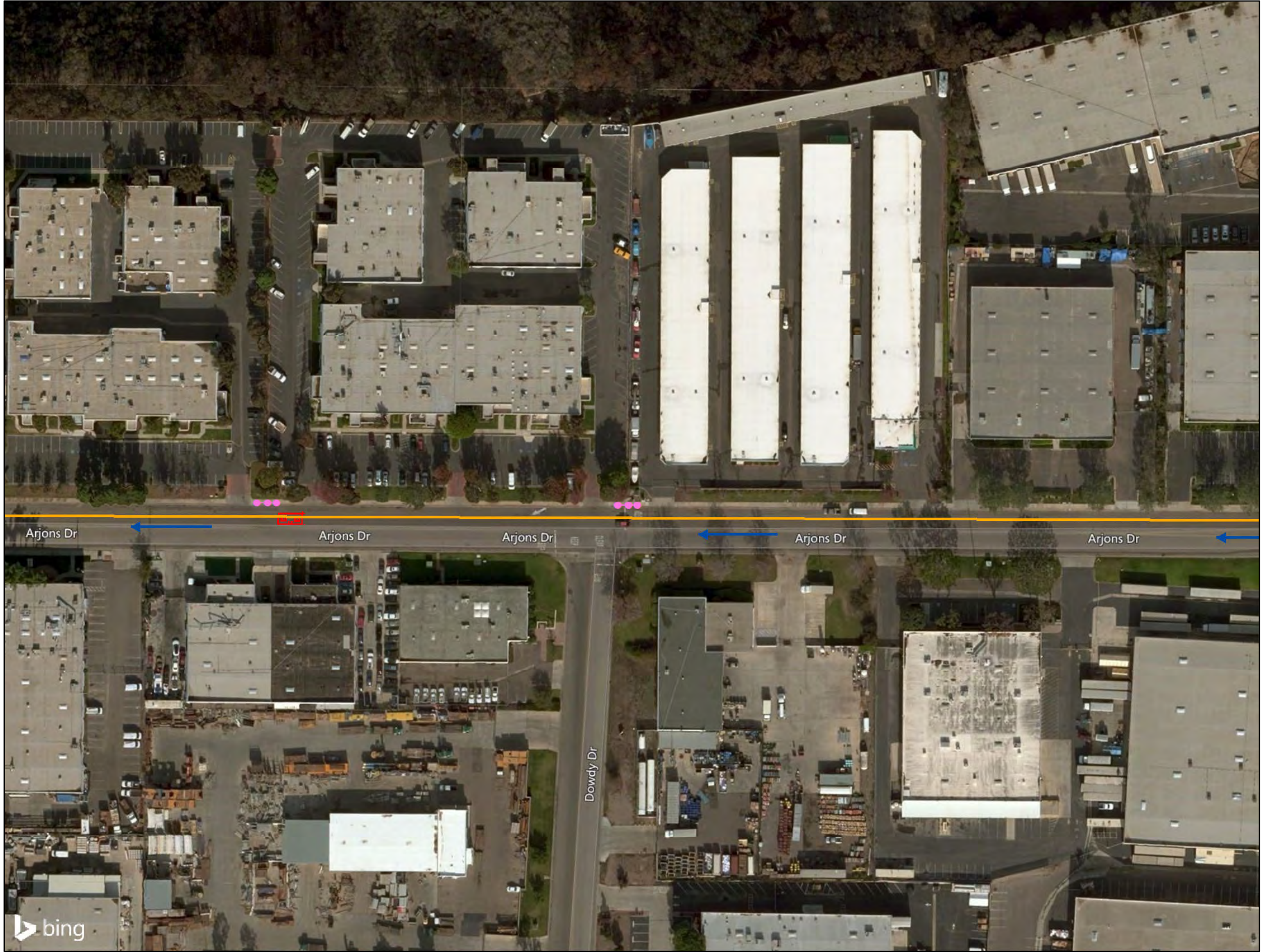

**Sycamore to Peñasquitos
230kV Transmission
Line Project
SWPPP Detail Map
Sheet 32 of 68**

DRAFT

-  Tracking Control
 -  Flow Direction
 -  Silt Fence
 -  Fiber Roll
 -  Storm Drain Inlet Protection
 -  Streams & Rivers
- Project Features**
-  Entrance Point
 -  Project Overhead TL
 -  Project Underground TL
 -  Access Road
 -  Underground Vault
 -  Potential Staging Yards
 -  Temporary Work Area
 -  Permanent Impact

Notes:
Locations of perimeter control BMPs are not to scale. BMP locations are conceptual in nature and must be field-verified prior to construction. Protect all inlets where applicable. Staging yards may be active during any time of construction.

SDG&E is providing this map with the understanding that the map is not survey grade. Certain technology used under license from AT&T Intellectual Property I, L.P. Copyright ©1998 – 2007 AT&T Intellectual Property 1, L.P. All Rights Reserved.

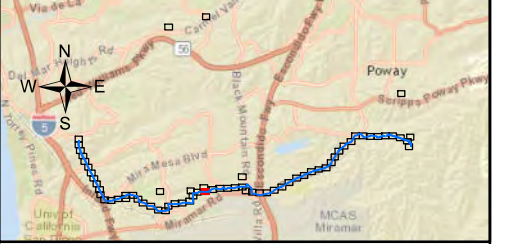
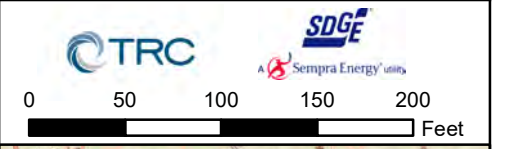



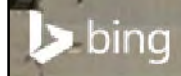





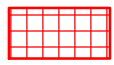





Service Layer Credits: Sources: Esri, HERE, DeLorme, USGS, Intermap, INCREMENT P, NRCan, Esri Japan, METI, Esri China (Hong Kong), Esri Korea, Esri (Thailand), MapmyIndia, NGCC, © OpenStreetMap contributors, and the GIS User Community © 2016 Microsoft Corporation © 2010 NAVTEQ © AND





**Sycamore to Peñasquitos
230kV Transmission
Line Project
SWPPP Detail Map
Sheet 33 of 68**

- DRAFT**
-  Tracking Control
 -  Flow Direction
 -  Silt Fence
 -  Fiber Roll
 -  Storm Drain Inlet Protection
 -  Streams & Rivers
- Project Features**
-  Entrance Point
 -  Project Overhead TL
 -  Project Underground TL
 -  Access Road
 -  Underground Vault
 -  Potential Staging Yards
 -  Temporary Work Area
 -  Permanent Impact

Notes:
Locations of perimeter control BMPs are not to scale. BMP locations are conceptual in nature and must be field-verified prior to construction. Protect all inlets where applicable. Staging yards may be active during any time of construction.

SDG&E is providing this map with the understanding that the map is not survey grade. Certain technology used under license from AT&T Intellectual Property I, L.P. Copyright ©1998 – 2007 AT&T Intellectual Property 1, L.P. All Rights Reserved.

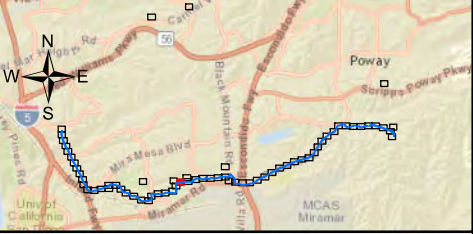
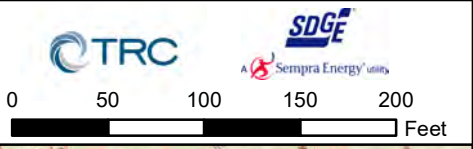

Service Layer Credits: Sources: Esri, HERE, DeLorme, USGS, Intermap, INCREMENT P, NRCan, Esri Japan, METI, Esri China (Hong Kong), Esri Korea, Esri (Thailand), MapmyIndia, NGCC, OpenStreetMap contributors, and the GIS User Community © 2016 Microsoft Corporation © 2010 NAVTEQ © AND

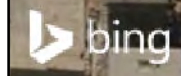

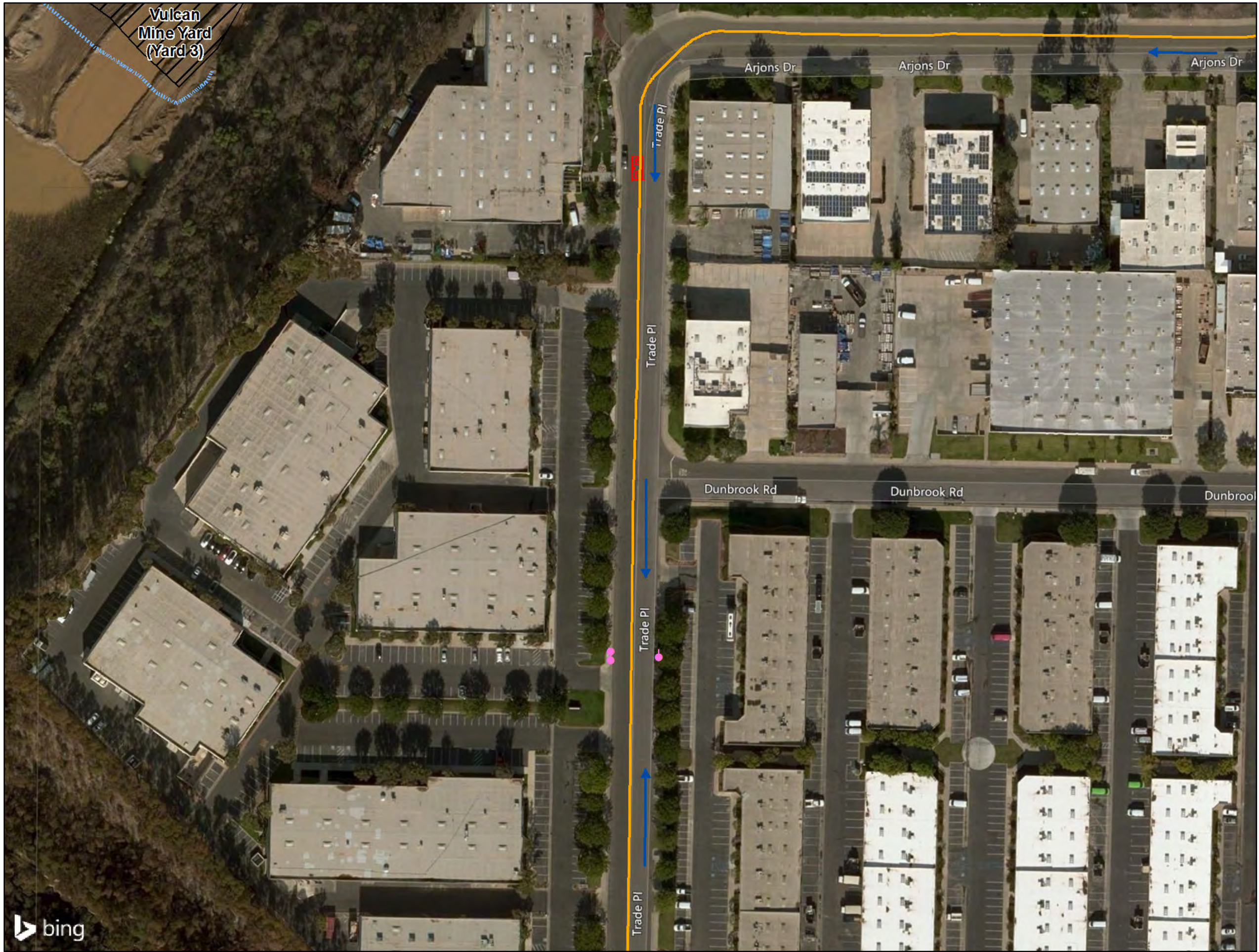

**Sycamore to Peñasquitos
230kV Transmission
Line Project
SWPPP Detail Map
Sheet 34 of 68**

- DRAFT**
- Tracking Control
 - Flow Direction
 - Silt Fence
 - Fiber Roll
 - Storm Drain Inlet Protection
 - Streams & Rivers
- Project Features**
- Entrance Point
 - Project Overhead TL
 - Project Underground TL
 - Access Road
 - Underground Vault
 - Potential Staging Yards
 - Temporary Work Area
 - Permanent Impact

Notes:
Locations of perimeter control BMPs are not to scale. BMP locations are conceptual in nature and must be field-verified prior to construction. Protect all inlets where applicable. Staging yards may be active during any time of construction.

SDG&E is providing this map with the understanding that the map is not survey grade. Certain technology used under license from AT&T Intellectual Property I, L.P. Copyright ©1998 – 2007 AT&T Intellectual Property 1, L.P. All Rights Reserved.

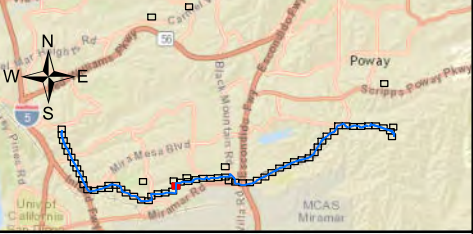
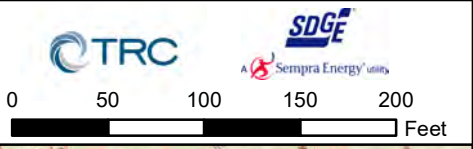

Service Layer Credits: Sources: Esri, HERE, DeLorme, USGS, Intermap, INCREMENT P, NRCan, Esri Japan, METI, Esri China (Hong Kong), Esri Korea, Esri (Thailand), MapmyIndia, NGCC, © OpenStreetMap contributors, and the GIS User Community © 2016 Microsoft Corporation © 2010 NAVTEQ © AND



**Sycamore to Peñasquitos
230kV Transmission
Line Project
SWPPP Detail Map
Sheet 35 of 68**

- DRAFT**
- Tracking Control
 - Flow Direction
 - Silt Fence
 - Fiber Roll
 - Storm Drain Inlet Protection
 - Streams & Rivers
- Project Features**
- Entrance Point
 - Project Overhead TL
 - Project Underground TL
 - Access Road
 - Underground Vault
 - Potential Staging Yards
 - Temporary Work Area
 - Permanent Impact

Notes:
Locations of perimeter control BMPs are not to scale. BMP locations are conceptual in nature and must be field-verified prior to construction. Protect all inlets where applicable. Staging yards may be active during any time of construction.

SDG&E is providing this map with the understanding that the map is not survey grade. Certain technology used under license from AT&T Intellectual Property I, L.P. Copyright ©1998 – 2007 AT&T Intellectual Property 1, L.P. All Rights Reserved.

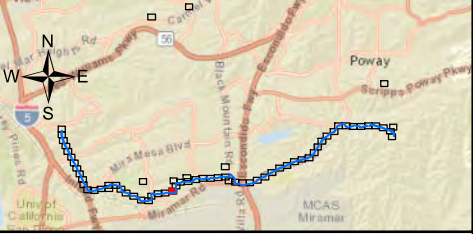
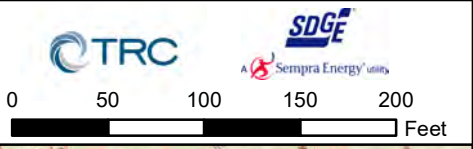

Service Layer Credits: Sources: Esri, HERE, DeLorme, USGS, Intermap, INCREMENT P, NRCan, Esri Japan, METI, Esri China (Hong Kong), Esri Korea, Esri (Thailand), MapmyIndia, NGCC, © OpenStreetMap contributors, and the GIS User Community © 2016 Microsoft Corporation © 2010 NAVTEQ © AND

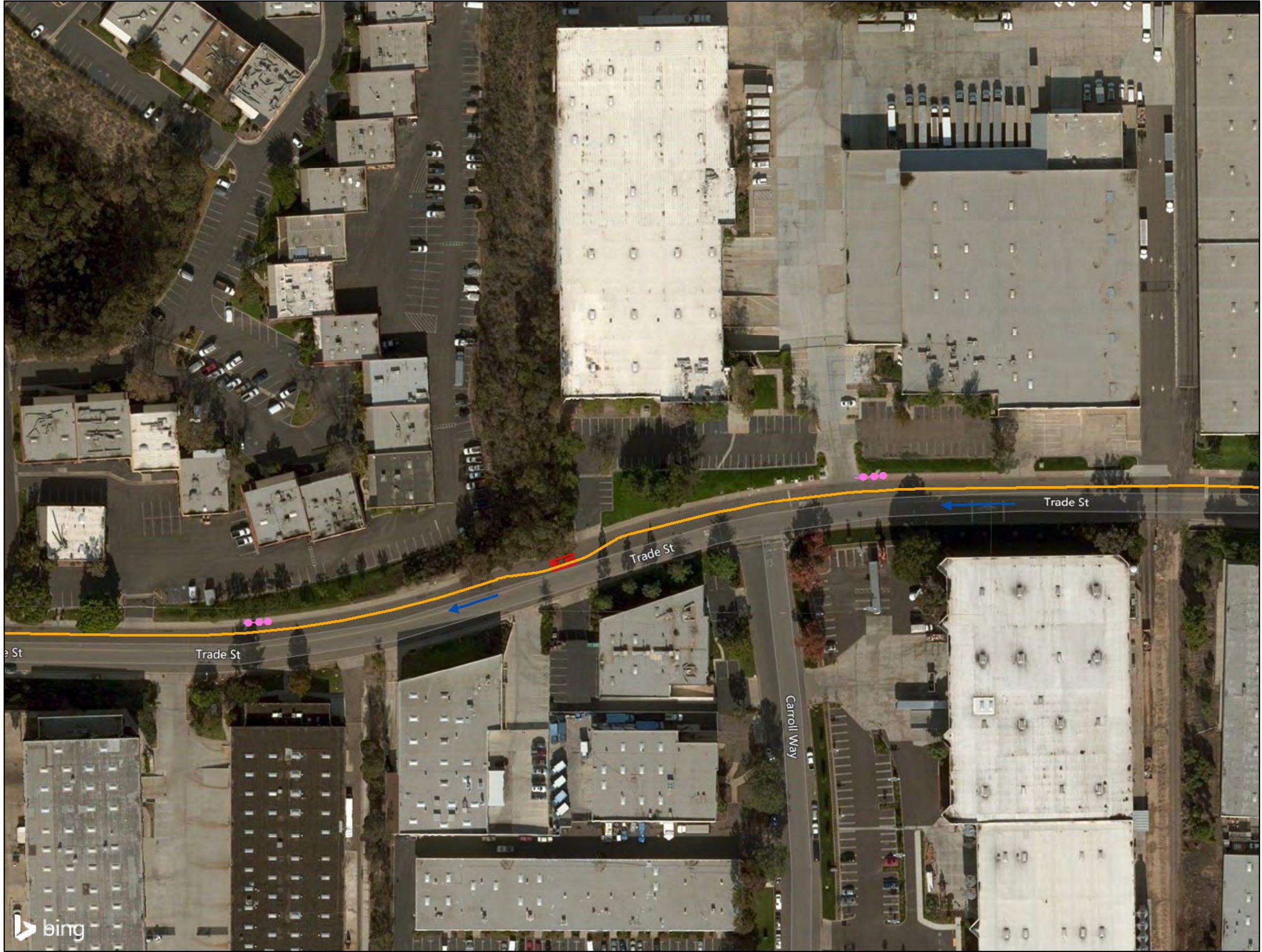

**Sycamore to Peñasquitos
230kV Transmission
Line Project
SWPPP Detail Map
Sheet 36 of 68**

- DRAFT**
- Tracking Control
 - Flow Direction
 - Silt Fence
 - Fiber Roll
 - Storm Drain Inlet Protection
 - Streams & Rivers
- Project Features**
- Entrance Point
 - Project Overhead TL
 - Project Underground TL
 - Access Road
 - Underground Vault
 - Potential Staging Yards
 - Temporary Work Area
 - Permanent Impact

Notes:
Locations of perimeter control BMPs are not to scale. BMP locations are conceptual in nature and must be field-verified prior to construction. Protect all inlets where applicable. Staging yards may be active during any time of construction.

SDG&E is providing this map with the understanding that the map is not survey grade. Certain technology used under license from AT&T Intellectual Property I, L.P. Copyright ©1998 – 2007 AT&T Intellectual Property 1, L.P. All Rights Reserved.

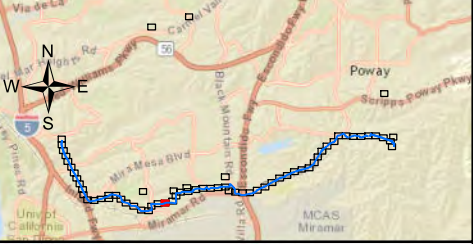
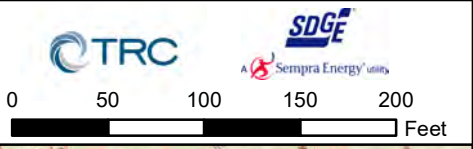

Service Layer Credits: Sources: Esri, HERE, DeLorme, USGS, Intermap, INCREMENT P, NRCan, Esri Japan, METI, Esri China (Hong Kong), Esri Korea, Esri (Thailand), MapmyIndia, NGCC, OpenStreetMap contributors, and the GIS User Community
© 2016 Microsoft Corporation © 2010 NAVTEQ © AND



**Sycamore to Peñasquitos
230kV Transmission
Line Project
SWPPP Detail Map
Sheet 37 of 68**

- DRAFT**
- Tracking Control
 - Flow Direction
 - Silt Fence
 - Fiber Roll
 - Storm Drain Inlet Protection
 - Streams & Rivers
- Project Features**
- Entrance Point
 - Project Overhead TL
 - Project Underground TL
 - Access Road
 - Underground Vault
 - Potential Staging Yards
 - Temporary Work Area
 - Permanent Impact

Notes:
Locations of perimeter control BMPs are not to scale. BMP locations are conceptual in nature and must be field-verified prior to construction. Protect all inlets where applicable. Staging yards may be active during any time of construction.

SDG&E is providing this map with the understanding that the map is not survey grade. Certain technology used under license from AT&T Intellectual Property I, L.P. Copyright ©1998 – 2007 AT&T Intellectual Property 1, L.P. All Rights Reserved.

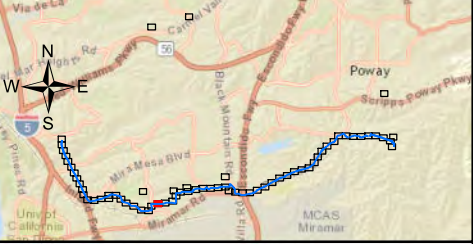
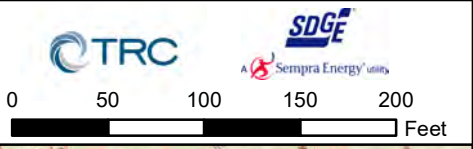

Service Layer Credits: Sources: Esri, HERE, DeLorme, USGS, Intermap, INCREMENT P, NRCan, Esri Japan, METI, Esri China (Hong Kong), Esri Korea, Esri (Thailand), MapmyIndia, NGCC, © OpenStreetMap contributors, and the GIS User Community © 2016 Microsoft Corporation © 2010 NAVTEQ © AND

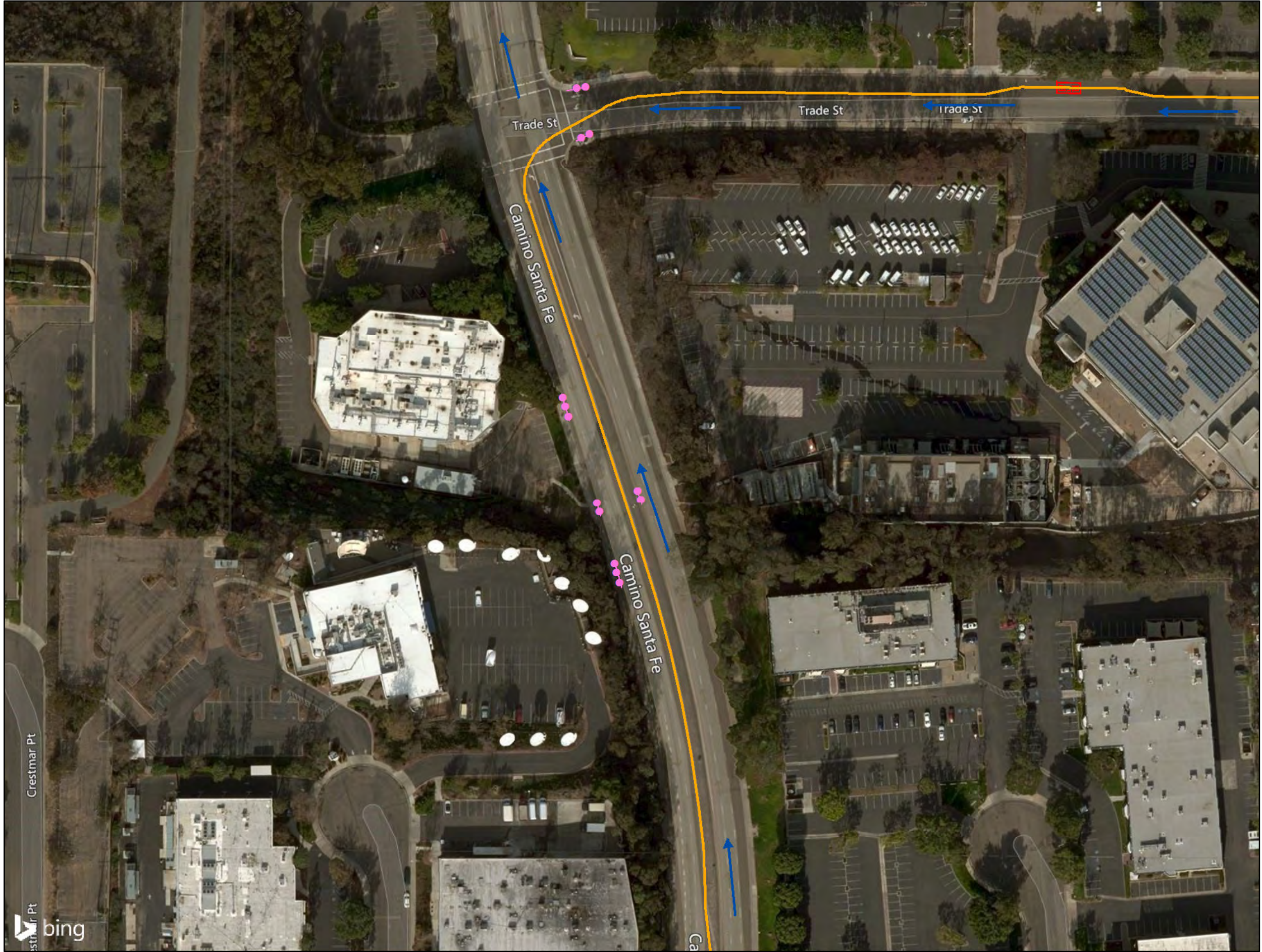

**Sycamore to Peñasquitos
230kV Transmission
Line Project
SWPPP Detail Map
Sheet 38 of 68**

- Tracking Control** **DRAFT**
- Tracking Control
 - Flow Direction
 - Silt Fence
 - Fiber Roll
 - Storm Drain Inlet Protection
 - Streams & Rivers
- Project Features**
- Entrance Point
 - Project Overhead TL
 - Project Underground TL
 - Access Road
 - Underground Vault
 - Potential Staging Yards
 - Temporary Work Area
 - Permanent Impact

Notes:
Locations of perimeter control BMPs are not to scale. BMP locations are conceptual in nature and must be field-verified prior to construction. Protect all inlets where applicable. Staging yards may be active during any time of construction.

SDG&E is providing this map with the understanding that the map is not survey grade. Certain technology used under license from AT&T Intellectual Property L, L.P. Copyright ©1998 – 2007 AT&T Intellectual Property 1, L.P. All Rights Reserved.

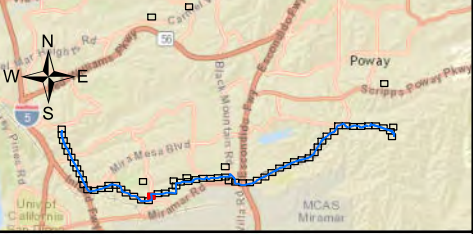
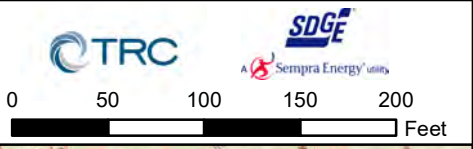















Service Layer Credits: Sources: Esri, HERE, DeLorme, USGS, Intermap, INCREMENT P, NRCan, Esri Japan, METI, Esri China (Hong Kong), Esri Korea, Esri (Thailand), MapmyIndia, NGCC, OpenStreetMap contributors, and the GIS User Community © 2016 Microsoft Corporation © 2010 NAVTEQ © AND

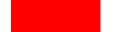

**Sycamore to Peñasquitos
230kV Transmission
Line Project
SWPPP Detail Map
Sheet 39 of 68**

DRAFT

-  Tracking Control
-  Flow Direction
-  Silt Fence
-  Fiber Roll
-  Storm Drain Inlet Protection
-  Streams & Rivers
- Project Features**
-  Entrance Point
-  Project Overhead TL
-  Project Underground TL
-  Access Road
-  Underground Vault
-  Potential Staging Yards
-  Temporary Work Area
-  Permanent Impact

Notes:
Locations of perimeter control BMPs are not to scale. BMP locations are conceptual in nature and must be field-verified prior to construction. Protect all inlets where applicable. Staging yards may be active during any time of construction.

SDG&E is providing this map with the understanding that the map is not survey grade. Certain technology used under license from AT&T Intellectual Property I, L.P. Copyright ©1998 – 2007 AT&T Intellectual Property 1, L.P. All Rights Reserved.

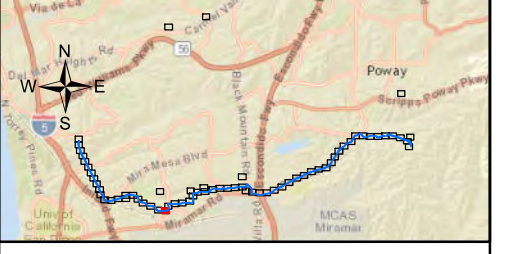
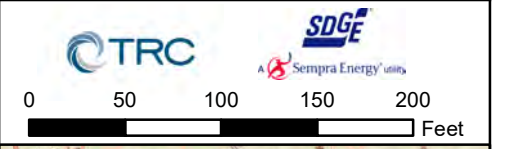



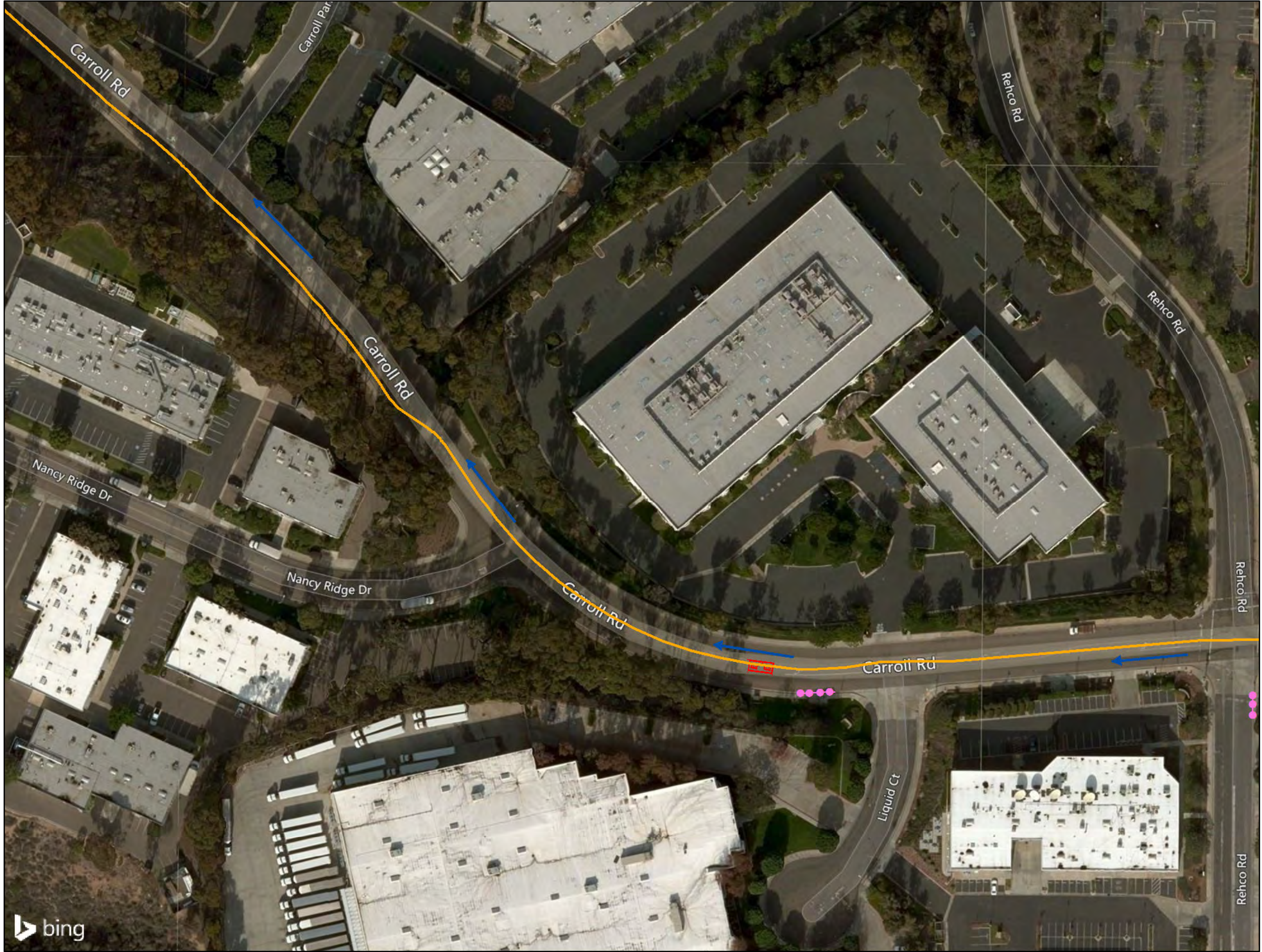



Service Layer Credits: Sources: Esri, HERE, DeLorme, USGS, Intermap, INCREMENT P, NRCan, Esri Japan, METI, Esri China (Hong Kong), Esri Korea, Esri (Thailand), MapmyIndia, NGCC, OpenStreetMap contributors, and the GIS User Community © 2016 Microsoft Corporation © 2010 NAVTEQ © AND











**Sycamore to Peñasquitos
230kV Transmission
Line Project
SWPPP Detail Map
Sheet 40 of 68**

DRAFT

-  Tracking Control
-  Flow Direction
-  Silt Fence
-  Fiber Roll
-  Storm Drain Inlet Protection
-  Streams & Rivers

Project Features

-  Entrance Point
-  Project Overhead TL
-  Project Underground TL
-  Access Road
-  Underground Vault
-  Potential Staging Yards
-  Temporary Work Area
-  Permanent Impact

Notes:
Locations of perimeter control BMPs are not to scale. BMP locations are conceptual in nature and must be field-verified prior to construction. Protect all inlets where applicable. Staging yards may be active during any time of construction.

SDG&E is providing this map with the understanding that the map is not survey grade. Certain technology used under license from AT&T Intellectual Property I, L.P. Copyright ©1998 – 2007 AT&T Intellectual Property 1, L.P. All Rights Reserved.

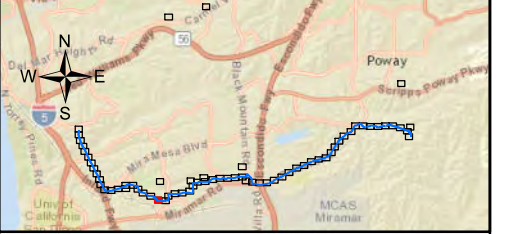
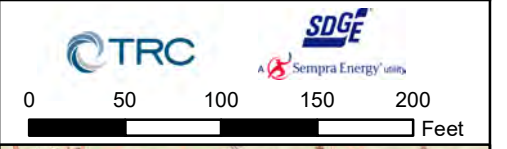

Service Layer Credits: Sources: Esri, HERE, DeLorme, USGS, Intermap, INCREMENT P, NRCan, Esri Japan, METI, Esri China (Hong Kong), Esri Korea, Esri (Thailand), MapmyIndia, NGCC, © OpenStreetMap contributors, and the GIS User Community © 2016 Microsoft Corporation © 2010 NAVTEQ © AND

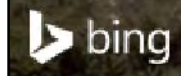



**Sycamore to Peñasquitos
230kV Transmission
Line Project
SWPPP Detail Map
Sheet 41 of 68**

- DRAFT**
- Tracking Control
 - Flow Direction
 - Silt Fence
 - Fiber Roll
 - Storm Drain Inlet Protection
 - Streams & Rivers
- Project Features**
- Entrance Point
 - Project Overhead TL
 - Project Underground TL
 - Access Road
 - Underground Vault
 - Potential Staging Yards
 - Temporary Work Area
 - Permanent Impact

Notes:
Locations of perimeter control BMPs are not to scale. BMP locations are conceptual in nature and must be field-verified prior to construction. Protect all inlets where applicable. Staging yards may be active during any time of construction.

SDG&E is providing this map with the understanding that the map is not survey grade. Certain technology used under license from AT&T Intellectual Property I, L.P. Copyright ©1998 – 2007 AT&T Intellectual Property 1, L.P. All Rights Reserved.

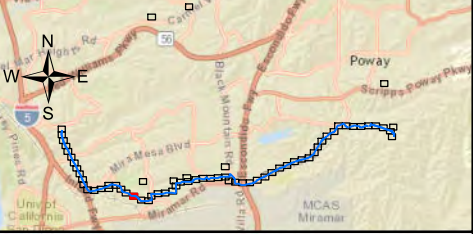
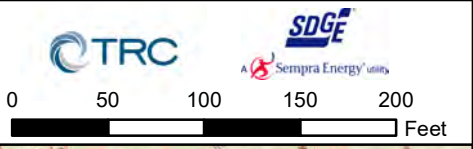

Service Layer Credits: Sources: Esri, HERE, DeLorme, USGS, Intermap, INCREMENT P, NRCan, Esri Japan, METI, Esri China (Hong Kong), Esri Korea, Esri (Thailand), MapmyIndia, NGCC, © OpenStreetMap contributors, and the GIS User Community © 2016 Microsoft Corporation © 2010 NAVTEQ © AND

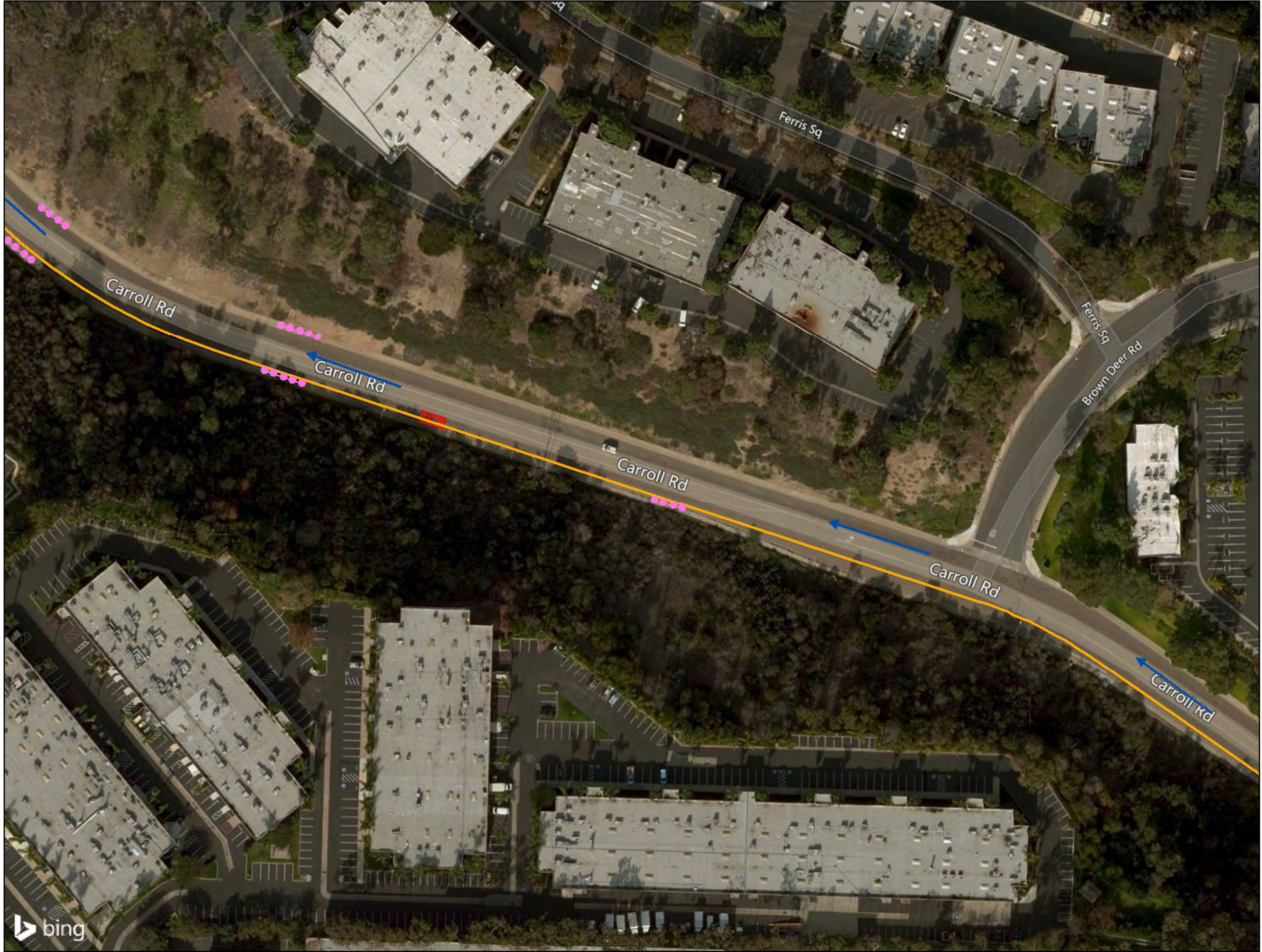

**Sycamore to Peñasquitos
230kV Transmission
Line Project
SWPPP Detail Map
Sheet 42 of 68**

DRAFT

-  Tracking Control
-  Flow Direction
-  Silt Fence
-  Fiber Roll
-  Storm Drain Inlet Protection
-  Streams & Rivers
- Project Features**
-  Entrance Point
-  Project Overhead TL
-  Project Underground TL
-  Access Road
-  Underground Vault
-  Potential Staging Yards
-  Temporary Work Area
-  Permanent Impact

Notes:
Locations of perimeter control BMPs are not to scale. BMP locations are conceptual in nature and must be field-verified prior to construction. Protect all inlets where applicable. Staging yards may be active during any time of construction.

SDG&E is providing this map with the understanding that the map is not survey grade. Certain technology used under license from AT&T Intellectual Property I, L.P. Copyright ©1998 – 2007 AT&T Intellectual Property 1, L.P. All Rights Reserved.

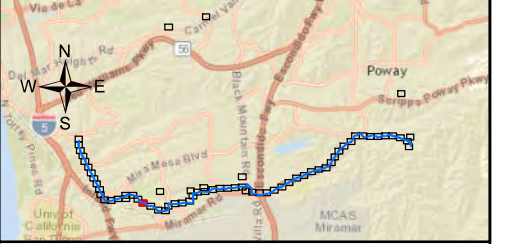
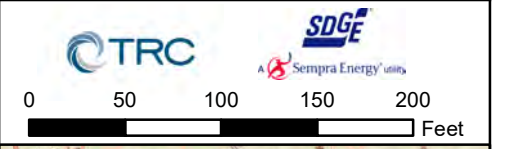

Service Layer Credits: Sources: Esri, HERE, DeLorme, USGS, Intermap, INCREMENT P, NRCan, Esri Japan, METI, Esri China (Hong Kong), Esri Korea, Esri (Thailand), MapmyIndia, NGCC, © OpenStreetMap contributors, and the GIS User Community © 2016 Microsoft Corporation © 2010 NAVTEQ © AND



**Sycamore to Peñasquitos
230kV Transmission
Line Project
SWPPP Detail Map
Sheet 43 of 68**

- DRAFT**
- Tracking Control
 - Flow Direction
 - Silt Fence
 - Fiber Roll
 - Storm Drain Inlet Protection
 - Streams & Rivers
- Project Features**
- Entrance Point
 - Project Overhead TL
 - Project Underground TL
 - Access Road
 - Underground Vault
 - Potential Staging Yards
 - Temporary Work Area
 - Permanent Impact

Notes:
Locations of perimeter control BMPs are not to scale. BMP locations are conceptual in nature and must be field-verified prior to construction. Protect all inlets where applicable. Staging yards may be active during any time of construction.

SDG&E is providing this map with the understanding that the map is not survey grade. Certain technology used under license from AT&T Intellectual Property L, L.P. Copyright ©1998 – 2007 AT&T Intellectual Property 1, L.P. All Rights Reserved.

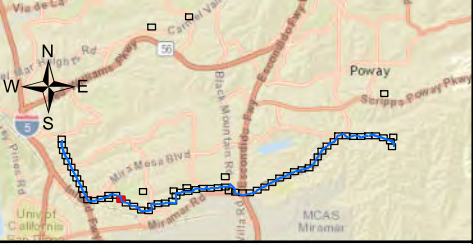
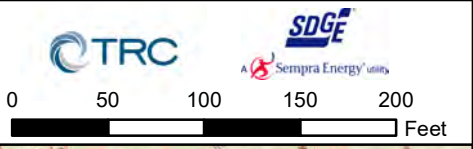

Service Layer Credits: Sources: Esri, HERE, DeLorme, USGS, Intermap, INCREMENT P, NRCan, Esri Japan, METI, Esri China (Hong Kong), Esri Korea, Esri (Thailand), MapmyIndia, NGCC, © OpenStreetMap contributors, and the GIS User Community © 2016 Microsoft Corporation © 2010 NAVTEQ © AND



**Sycamore to Peñasquitos
230kV Transmission
Line Project
SWPPP Detail Map
Sheet 44 of 68**

DRAFT

-  Tracking Control
 -  Flow Direction
 -  Silt Fence
 -  Fiber Roll
 -  Storm Drain Inlet Protection
 -  Streams & Rivers
- Project Features**
-  Entrance Point
 -  Project Overhead TL
 -  Project Underground TL
 -  Access Road
 -  Underground Vault
 -  Potential Staging Yards
 -  Temporary Work Area
 -  Permanent Impact

Notes:
Locations of perimeter control BMPs are not to scale. BMP locations are conceptual in nature and must be field-verified prior to construction. Protect all inlets where applicable. Staging yards may be active during any time of construction.

SDG&E is providing this map with the understanding that the map is not survey grade. Certain technology used under license from AT&T Intellectual Property I, L.P. Copyright ©1998 – 2007 AT&T Intellectual Property 1, L.P. All Rights Reserved.

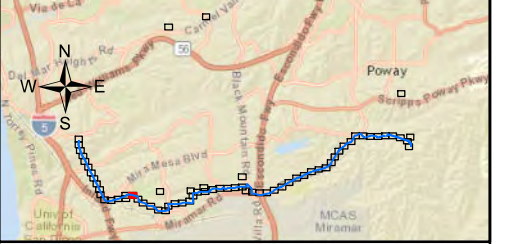
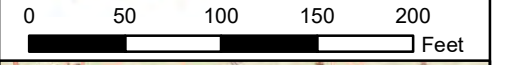



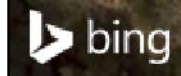



Service Layer Credits: Sources: Esri, HERE, DeLorme, USGS, Intermap, INCREMENT P, NRCan, Esri Japan, METI, Esri China (Hong Kong), Esri Korea, Esri (Thailand), MapmyIndia, NGCC, © OpenStreetMap contributors, and the GIS User Community © 2016 Microsoft Corporation © 2010 NAVTEQ © AND













**Sycamore to Peñasquitos
230kV Transmission
Line Project
SWPPP Detail Map
Sheet 45 of 68**

DRAFT

-  Tracking Control
-  Flow Direction
-  Silt Fence
-  Fiber Roll
-  Storm Drain Inlet Protection
-  Streams & Rivers

Project Features

-  Entrance Point
-  Project Overhead TL
-  Project Underground TL
-  Access Road
-  Underground Vault
-  Potential Staging Yards
-  Temporary Work Area
-  Permanent Impact

Notes:
Locations of perimeter control BMPs are not to scale. BMP locations are conceptual in nature and must be field-verified prior to construction. Protect all inlets where applicable. Staging yards may be active during any time of construction.

SDG&E is providing this map with the understanding that the map is not survey grade. Certain technology used under license from AT&T Intellectual Property I, L.P. Copyright ©1998 – 2007 AT&T Intellectual Property 1, L.P. All Rights Reserved.

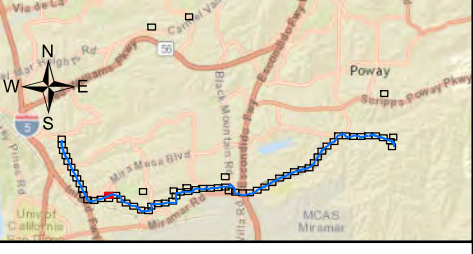
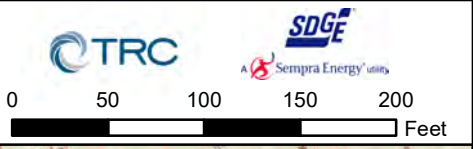











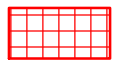



Service Layer Credits: Sources: Esri, HERE, DeLorme, USGS, Intermap, INCREMENT P, NRCan, Esri Japan, METI, Esri China (Hong Kong), Esri Korea, Esri (Thailand), MapmyIndia, NGCC, © OpenStreetMap contributors, and the GIS User Community © 2016 Microsoft Corporation © 2010 NAVTEQ © AND



**Driving Range
Yard (Yard 5)**



**Sycamore to Peñasquitos
230kV Transmission
Line Project
SWPPP Detail Map
Sheet 46 of 68**

- DRAFT**
-  Tracking Control
 -  Flow Direction
 -  Silt Fence
 -  Fiber Roll
 -  Storm Drain Inlet Protection
 -  Streams & Rivers
- Project Features**
-  Entrance Point
 -  Project Overhead TL
 -  Project Underground TL
 -  Access Road
 -  Underground Vault
 -  Potential Staging Yards
 -  Temporary Work Area
 -  Permanent Impact

Notes:
Locations of perimeter control BMPs are not to scale. BMP locations are conceptual in nature and must be field-verified prior to construction. Protect all inlets where applicable. Staging yards may be active during any time of construction.

SDG&E is providing this map with the understanding that the map is not survey grade. Certain technology used under license from AT&T Intellectual Property I, L.P. Copyright ©1998 – 2007 AT&T Intellectual Property 1, L.P. All Rights Reserved.

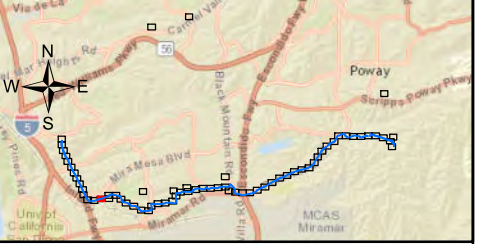
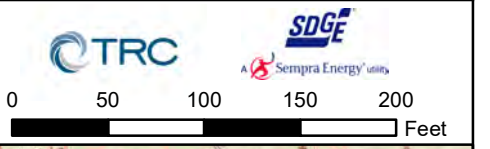



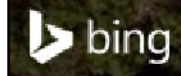



Service Layer Credits: Sources: Esri, HERE, DeLorme, USGS, Intermap, INCREMENT P, NRCan, Esri Japan, METI, Esri China (Hong Kong), Esri Korea, Esri (Thailand), MapmyIndia, NGCC, © OpenStreetMap contributors, and the GIS User Community © 2016 Microsoft Corporation © 2010 NAVTEQ © AND













**Sycamore to Peñasquitos
230kV Transmission
Line Project
SWPPP Detail Map
Sheet 47 of 68**

DRAFT

-  Tracking Control
-  Flow Direction
-  Silt Fence
-  Fiber Roll
-  Storm Drain Inlet Protection
-  Streams & Rivers

Project Features

-  Entrance Point
-  Project Overhead TL
-  Project Underground TL
-  Access Road
-  Underground Vault
-  Potential Staging Yards
-  Temporary Work Area
-  Permanent Impact

Notes:
Locations of perimeter control BMPs are not to scale. BMP locations are conceptual in nature and must be field-verified prior to construction. Protect all inlets where applicable. Staging yards may be active during any time of construction.

SDG&E is providing this map with the understanding that the map is not survey grade. Certain technology used under license from AT&T Intellectual Property I, L.P. Copyright ©1998 – 2007 AT&T Intellectual Property 1, L.P. All Rights Reserved.

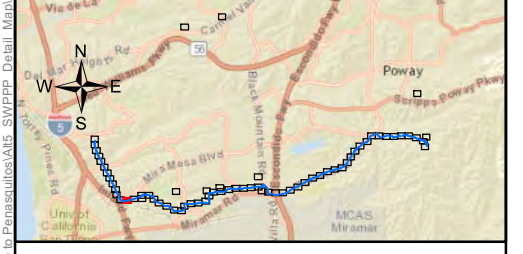

Service Layer Credits: Sources: Esri, HERE, DeLorme, USGS, Intermap, INCREMENT P, NRCan, Esri Japan, METI, Esri China (Hong Kong), Esri Korea, Esri (Thailand), MapmyIndia, NGCC, © OpenStreetMap contributors, and the GIS User Community © 2016 Microsoft Corporation © 2010 NAVTEQ © AND



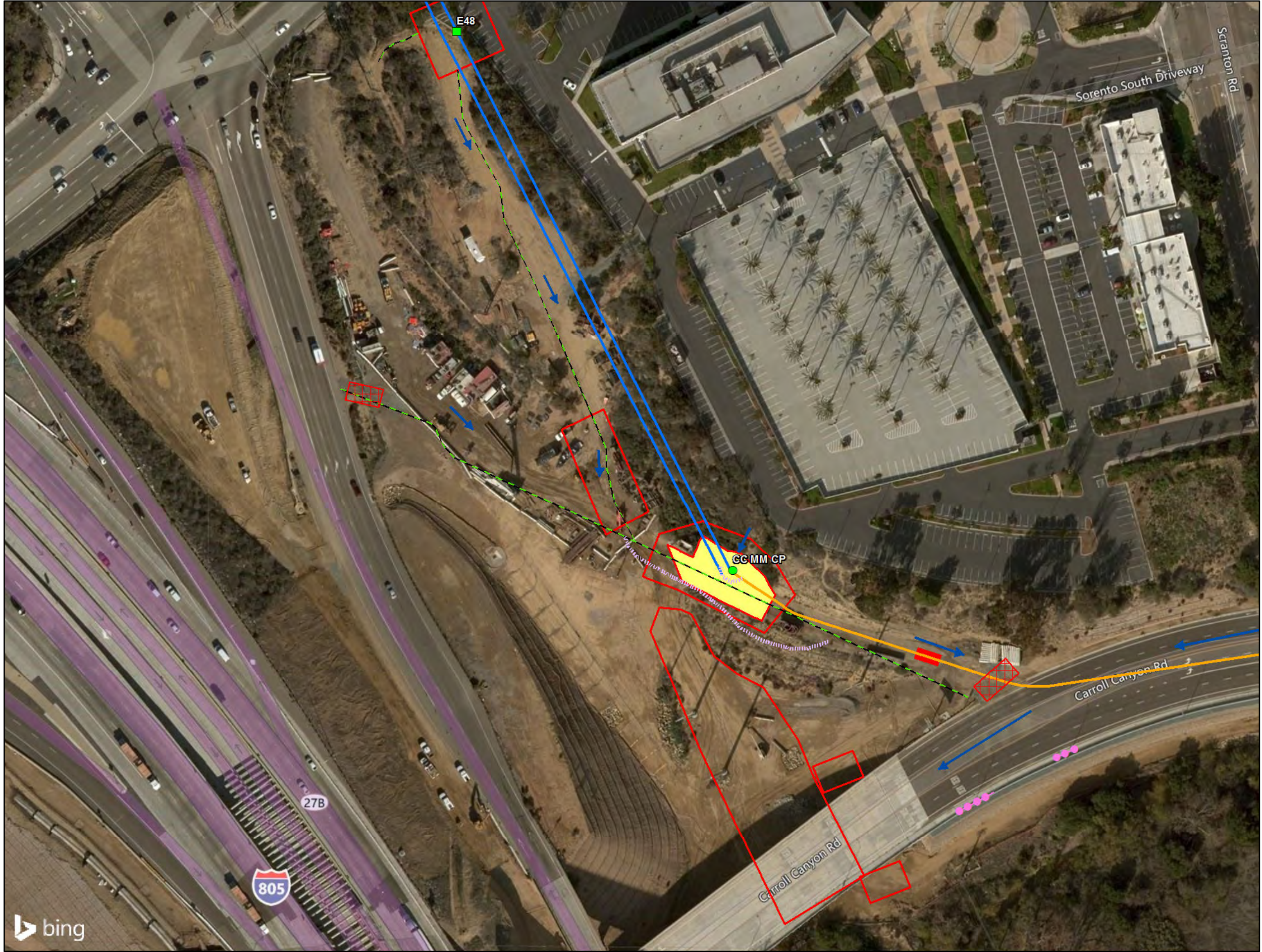

**Sycamore to Peñasquitos
230kV Transmission
Line Project
SWPPP Detail Map
Sheet 48 of 68**

DRAFT

-  Tracking Control
 -  Flow Direction
 -  Silt Fence
 -  Fiber Roll
 -  Storm Drain Inlet Protection
 -  Streams & Rivers
- Project Features**
-  Entrance Point
 -  Project Overhead TL
 -  Project Underground TL
 -  Access Road
 -  Underground Vault
 -  Potential Staging Yards
 -  Temporary Work Area
 -  Permanent Impact

Notes:
Locations of perimeter control BMPs are not to scale. BMP locations are conceptual in nature and must be field-verified prior to construction. Protect all inlets where applicable. Staging yards may be active during any time of construction.

SDG&E is providing this map with the understanding that the map is not survey grade. Certain technology used under license from AT&T Intellectual Property I, L.P. Copyright ©1998 – 2007 AT&T Intellectual Property I, L.P. All Rights Reserved.

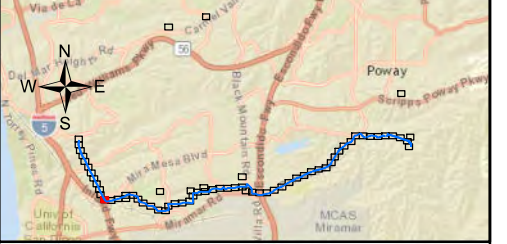
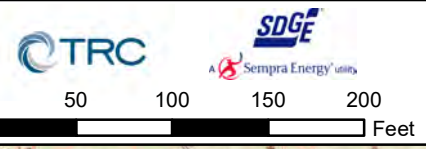

Service Layer Credits: Sources: Esri, HERE, DeLorme, USGS, Intermap, INCREMENT P, NRCan, Esri Japan, METI, Esri China (Hong Kong), Esri Korea, Esri (Thailand), MapmyIndia, NGCC, © OpenStreetMap contributors, and the GIS User Community © 2016 Microsoft Corporation © 2010 NAVTEQ © AND

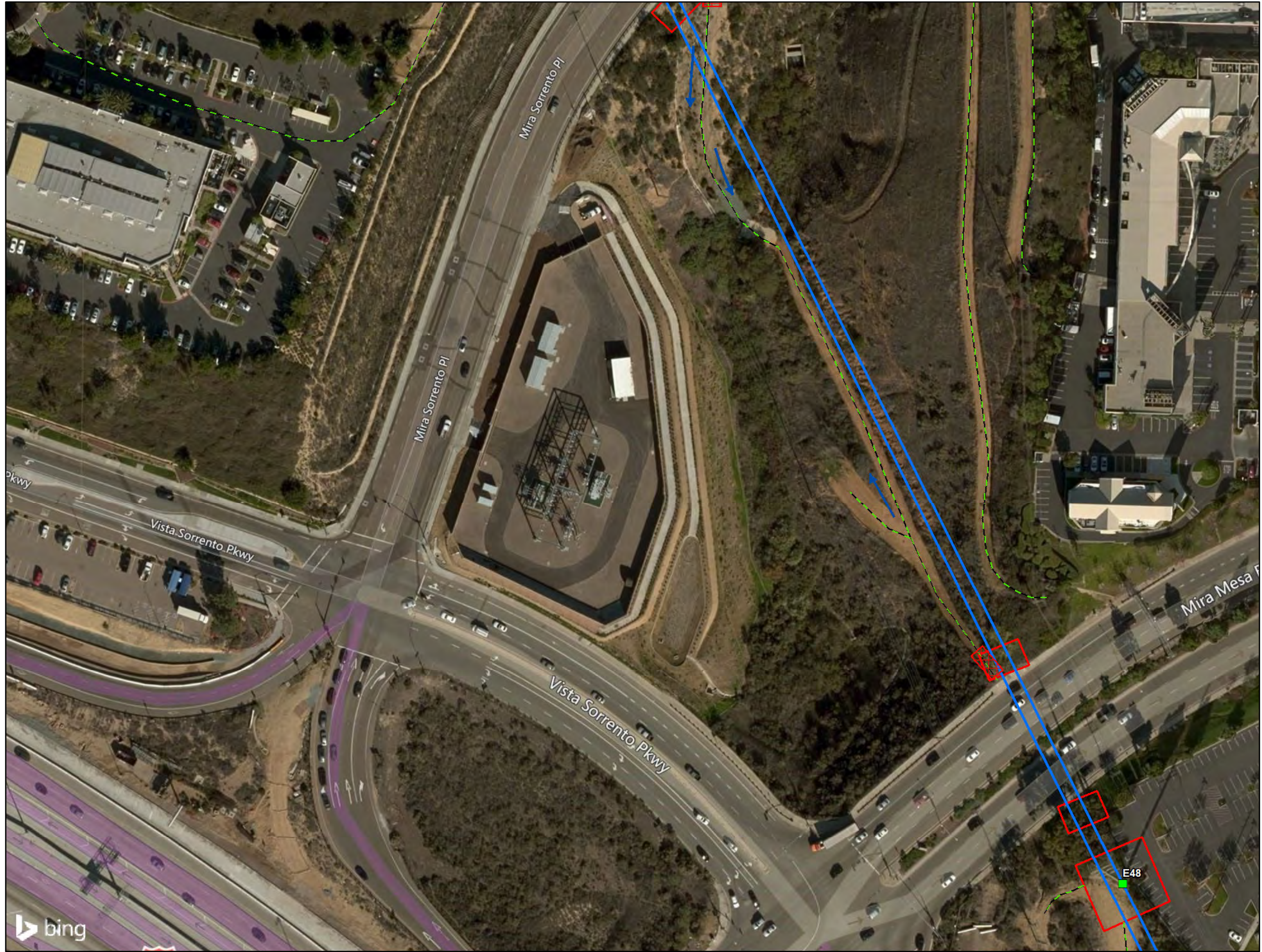

**Sycamore to Peñasquitos
230kV Transmission
Line Project
SWPPP Detail Map
Sheet 49 of 68**

DRAFT

-  Tracking Control
-  Flow Direction
-  Silt Fence
-  Fiber Roll
-  Storm Drain Inlet Protection
-  Streams & Rivers
- Project Features**
-  Entrance Point
-  Project Overhead TL
-  Project Underground TL
-  Access Road
-  Underground Vault
-  Potential Staging Yards
-  Temporary Work Area
-  Permanent Impact

Notes:
Locations of perimeter control BMPs are not to scale. BMP locations are conceptual in nature and must be field-verified prior to construction. Protect all inlets where applicable. Staging yards may be active during any time of construction.

SDG&E is providing this map with the understanding that the map is not survey grade. Certain technology used under license from AT&T Intellectual Property I, L.P. Copyright ©1998 – 2007 AT&T Intellectual Property 1, L.P. All Rights Reserved.

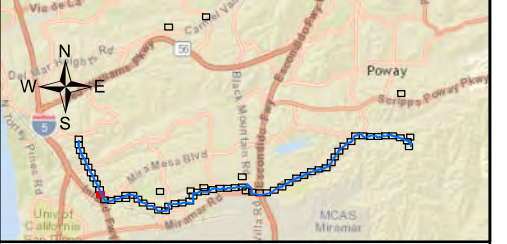
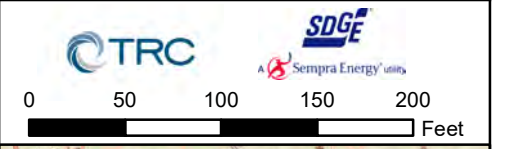

Service Layer Credits: Sources: Esri, HERE, DeLorme, USGS, Intermap, INCREMENT P, NRCan, Esri Japan, METI, Esri China (Hong Kong), Esri Korea, Esri (Thailand), MapmyIndia, NGCC, OpenStreetMap contributors, and the GIS User Community © 2016 Microsoft Corporation © 2010 NAVTEQ © AND

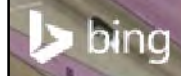



**Sycamore to Peñasquitos
230kV Transmission
Line Project
SWPPP Detail Map
Sheet 50 of 68**

DRAFT

-  Tracking Control
 -  Flow Direction
 -  Silt Fence
 -  Fiber Roll
 -  Storm Drain Inlet Protection
 -  Streams & Rivers
- Project Features**
-  Entrance Point
 -  Project Overhead TL
 -  Project Underground TL
 -  Access Road
 -  Underground Vault
 -  Potential Staging Yards
 -  Temporary Work Area
 -  Permanent Impact

Notes:
Locations of perimeter control BMPs are not to scale. BMP locations are conceptual in nature and must be field-verified prior to construction. Protect all inlets where applicable. Staging yards may be active during any time of construction.

SDG&E is providing this map with the understanding that the map is not survey grade. Certain technology used under license from AT&T Intellectual Property I, L.P. Copyright ©1998 – 2007 AT&T Intellectual Property 1, L.P. All Rights Reserved.

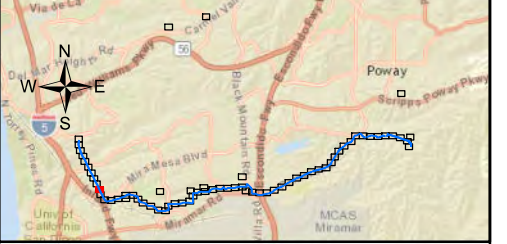
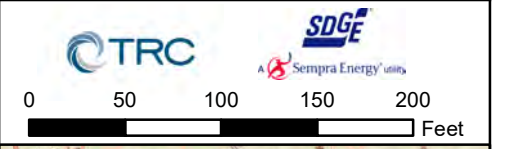















Service Layer Credits: Sources: Esri, HERE, DeLorme, USGS, Intermap, INCREMENT P, NRCan, Esri Japan, METI, Esri China (Hong Kong), Esri Korea, Esri (Thailand), MapmyIndia, NGCC, © OpenStreetMap contributors, and the GIS User Community © 2016 Microsoft Corporation © 2010 NAVTEQ © AND

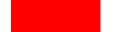

**Sycamore to Peñasquitos
230kV Transmission
Line Project
SWPPP Detail Map
Sheet 51 of 68**

DRAFT

-  Tracking Control
-  Flow Direction
-  Silt Fence
-  Fiber Roll
-  Storm Drain Inlet Protection
-  Streams & Rivers
- Project Features**
-  Entrance Point
-  Project Overhead TL
-  Project Underground TL
-  Access Road
-  Underground Vault
-  Potential Staging Yards
-  Temporary Work Area
-  Permanent Impact

Notes:
Locations of perimeter control BMPs are not to scale. BMP locations are conceptual in nature and must be field-verified prior to construction. Protect all inlets where applicable. Staging yards may be active during any time of construction.

SDG&E is providing this map with the understanding that the map is not survey grade. Certain technology used under license from AT&T Intellectual Property I, L.P. Copyright ©1998 – 2007 AT&T Intellectual Property 1, L.P. All Rights Reserved.

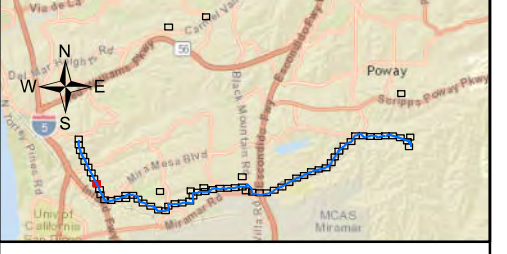
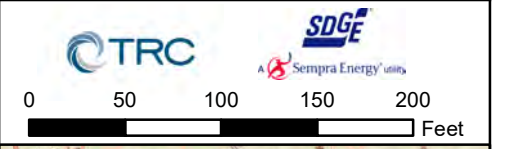

Service Layer Credits: Sources: Esri, HERE, DeLorme, USGS, Intermap, INCREMENT P, NRCan, Esri Japan, METI, Esri China (Hong Kong), Esri Korea, Esri (Thailand), MapmyIndia, NGCC, © OpenStreetMap contributors, and the GIS User Community © 2016 Microsoft Corporation © 2010 NAVTEQ © AND

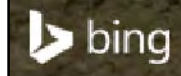

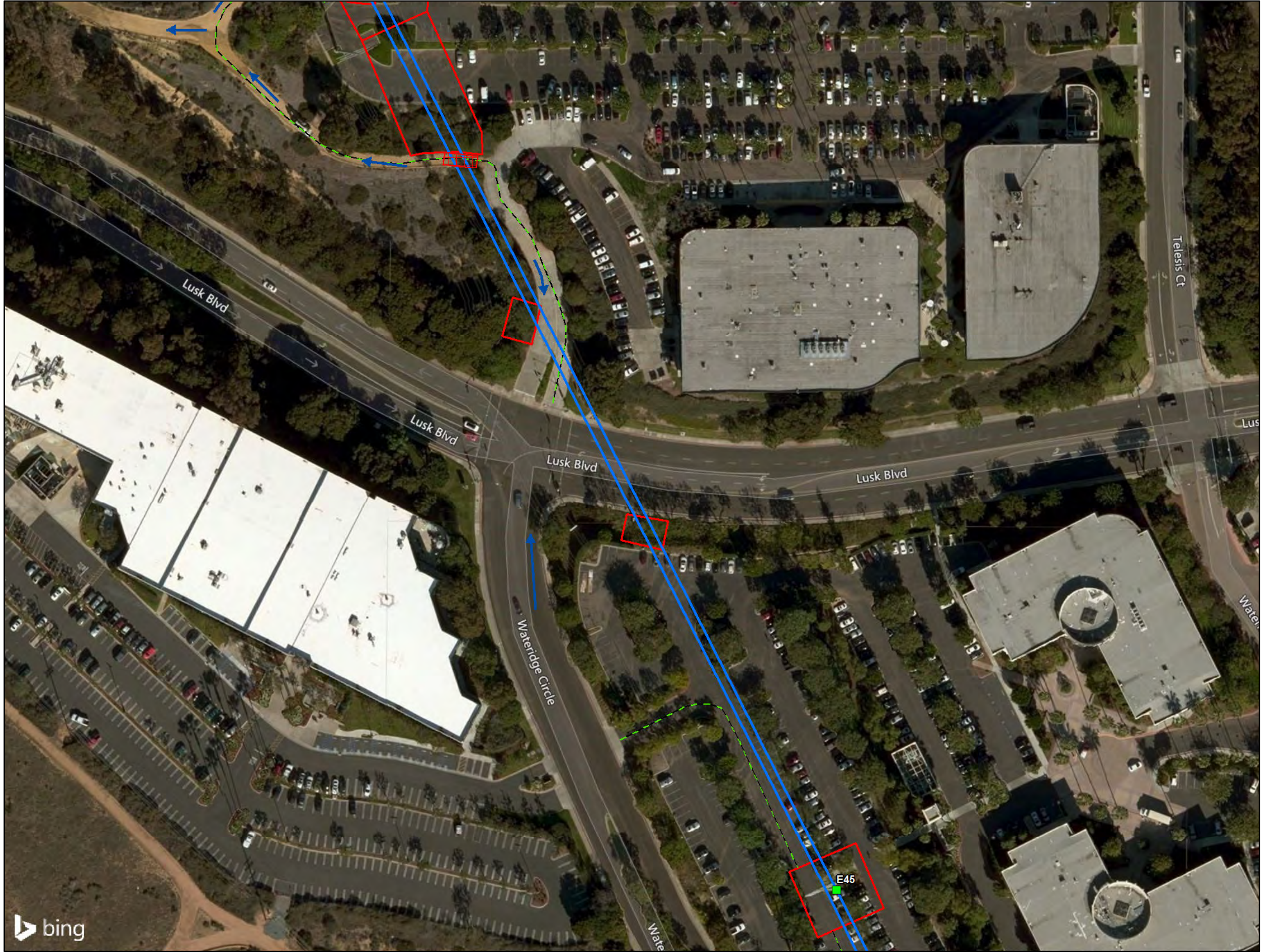

**Sycamore to Peñasquitos
230kV Transmission
Line Project
SWPPP Detail Map
Sheet 52 of 68**

DRAFT

-  Tracking Control
-  Flow Direction
-  Silt Fence
-  Fiber Roll
-  Storm Drain Inlet Protection
-  Streams & Rivers
- Project Features**
-  Entrance Point
-  Project Overhead TL
-  Project Underground TL
-  Access Road
-  Underground Vault
-  Potential Staging Yards
-  Temporary Work Area
-  Permanent Impact

Notes:
Locations of perimeter control BMPs are not to scale. BMP locations are conceptual in nature and must be field-verified prior to construction. Protect all inlets where applicable. Staging yards may be active during any time of construction.

SDG&E is providing this map with the understanding that the map is not survey grade. Certain technology used under license from AT&T Intellectual Property I, L.P. Copyright ©1998 – 2007 AT&T Intellectual Property 1, L.P. All Rights Reserved.

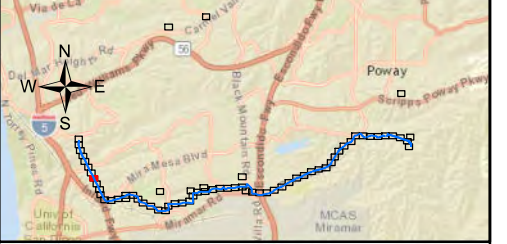
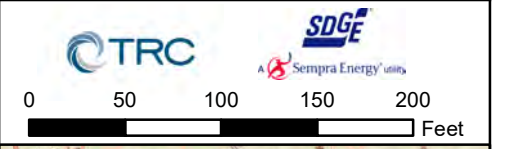

Service Layer Credits: Sources: Esri, HERE, DeLorme, USGS, Intermap, INCREMENT P, NRCan, Esri Japan, METI, Esri China (Hong Kong), Esri Korea, Esri (Thailand), MapmyIndia, NGCC, © OpenStreetMap contributors, and the GIS User Community © 2016 Microsoft Corporation © 2010 NAVTEQ © AND

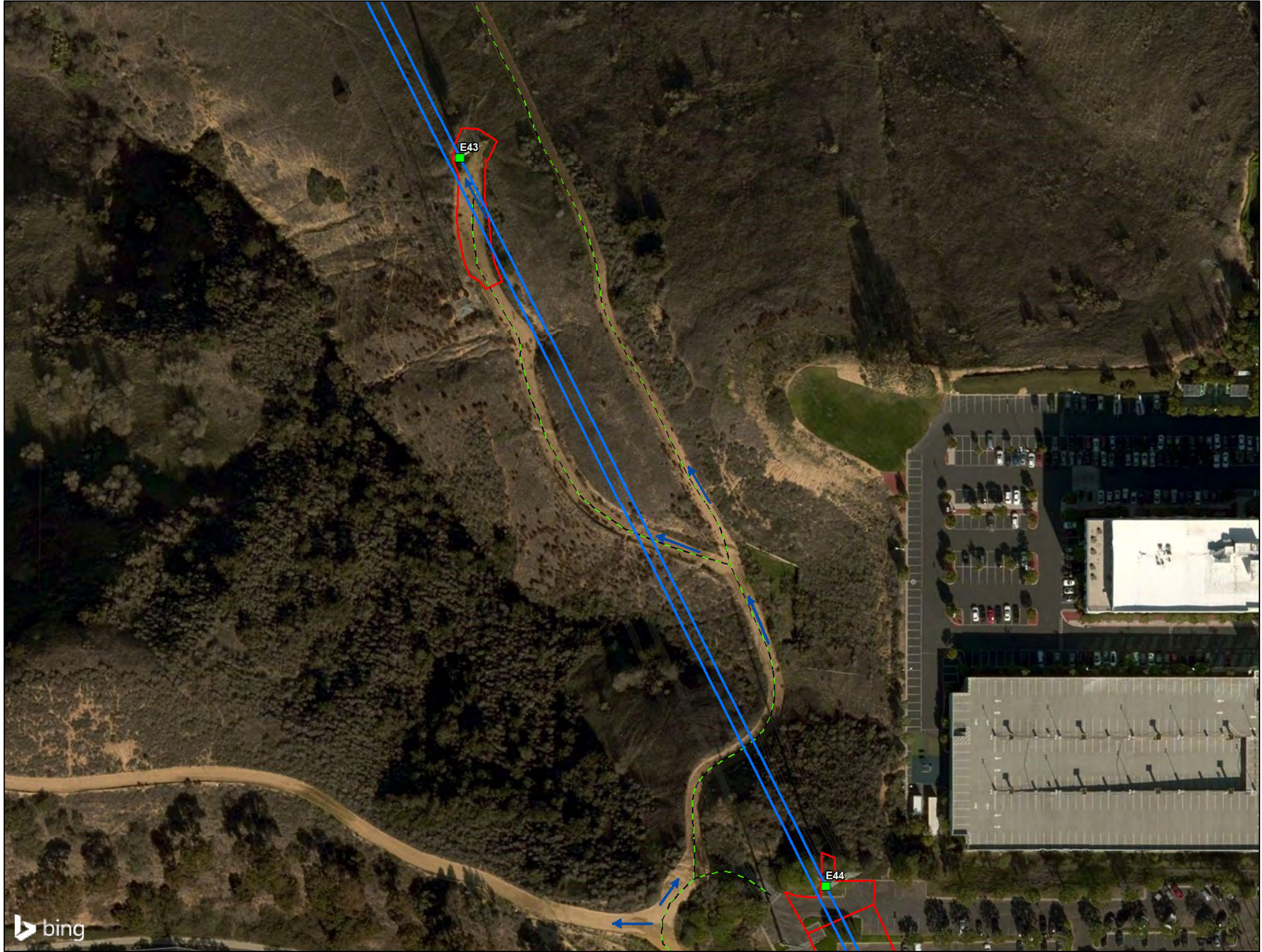

**Sycamore to Peñasquitos
230kV Transmission
Line Project
SWPPP Detail Map
Sheet 53 of 68**

- DRAFT**
- Tracking Control
 - Flow Direction
 - Silt Fence
 - Fiber Roll
 - Storm Drain Inlet Protection
 - Streams & Rivers
- Project Features**
- Entrance Point
 - Project Overhead TL
 - Project Underground TL
 - Access Road
 - Underground Vault
 - Potential Staging Yards
 - Temporary Work Area
 - Permanent Impact

Notes:
Locations of perimeter control BMPs are not to scale. BMP locations are conceptual in nature and must be field-verified prior to construction. Protect all inlets where applicable. Staging yards may be active during any time of construction.

SDG&E is providing this map with the understanding that the map is not survey grade. Certain technology used under license from AT&T Intellectual Property I, L.P. Copyright ©1998 – 2007 AT&T Intellectual Property 1, L.P. All Rights Reserved.

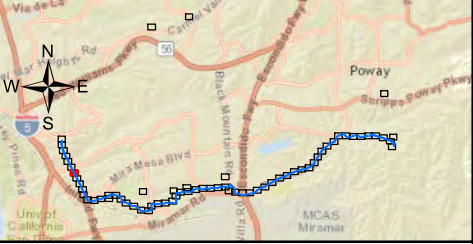
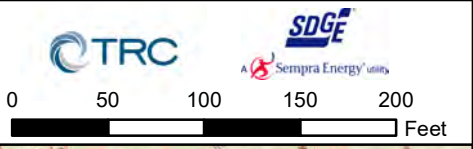

Service Layer Credits: Sources: Esri, HERE, DeLorme, USGS, Intermap, INCREMENT P, NRCan, Esri Japan, METI, Esri China (Hong Kong), Esri Korea, Esri (Thailand), MapmyIndia, NGCC, OpenStreetMap contributors, and the GIS User Community
© 2016 Microsoft Corporation © 2010 NAVTEQ © AND

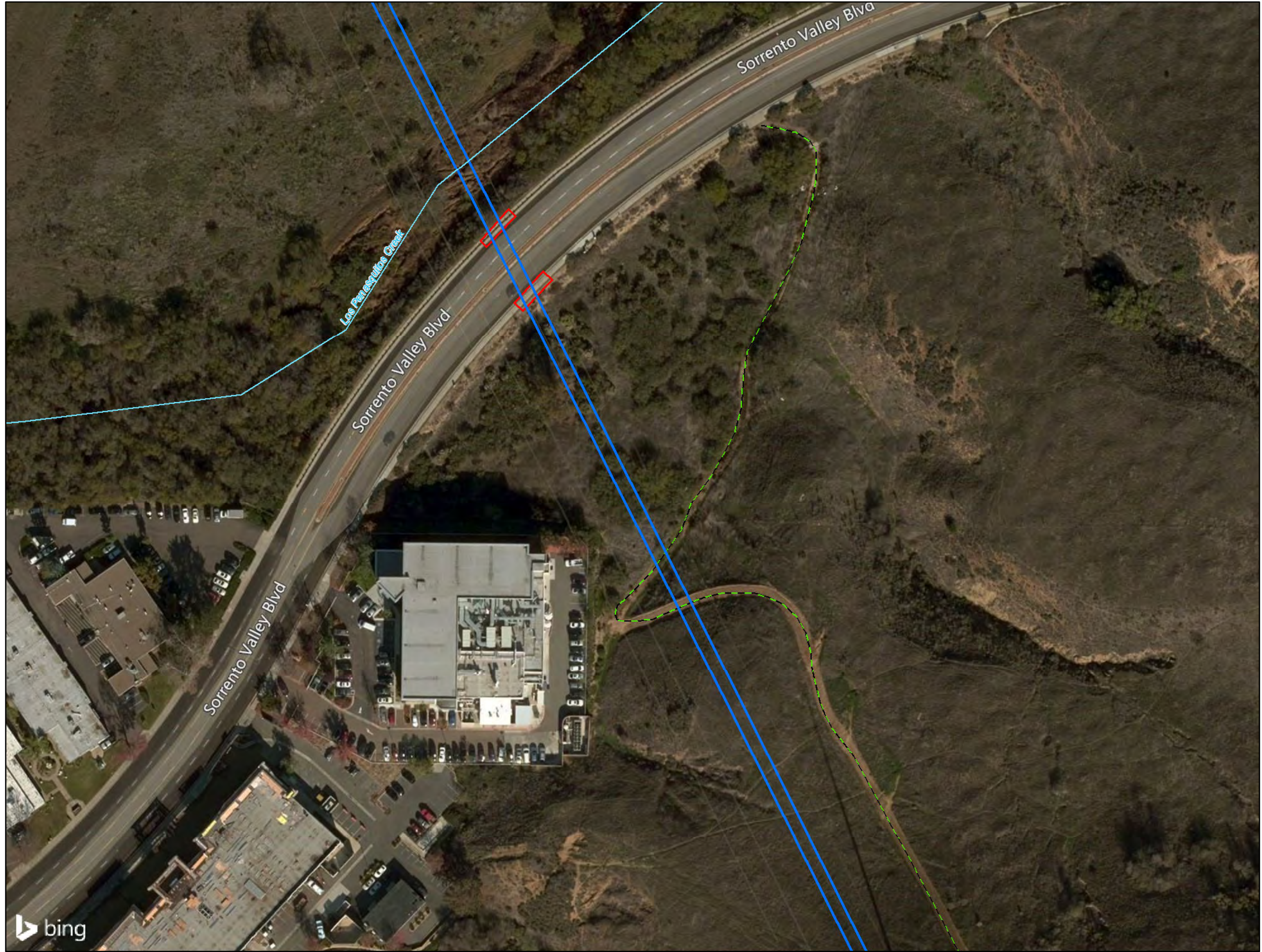

**Sycamore to Peñasquitos
230kV Transmission
Line Project
SWPPP Detail Map
Sheet 54 of 68**

- DRAFT**
- Tracking Control
 - Flow Direction
 - Silt Fence
 - Fiber Roll
 - Storm Drain Inlet Protection
 - Streams & Rivers
- Project Features**
- Entrance Point
 - Project Overhead TL
 - Project Underground TL
 - Access Road
 - Underground Vault
 - Potential Staging Yards
 - Temporary Work Area
 - Permanent Impact

Notes:
Locations of perimeter control BMPs are not to scale. BMP locations are conceptual in nature and must be field-verified prior to construction. Protect all inlets where applicable. Staging yards may be active during any time of construction.

SDG&E is providing this map with the understanding that the map is not survey grade. Certain technology used under license from AT&T Intellectual Property I, L.P. Copyright ©1998 – 2007 AT&T Intellectual Property 1, L.P. All Rights Reserved.

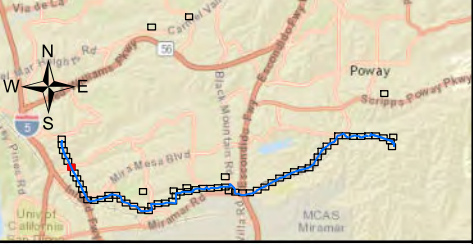
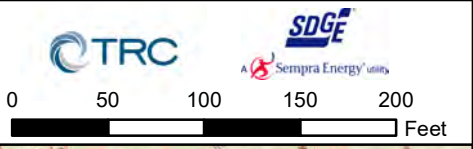

Service Layer Credits: Sources: Esri, HERE, DeLorme, USGS, Intermap, INCREMENT P, NRCan, Esri Japan, METI, Esri China (Hong Kong), Esri Korea, Esri (Thailand), MapmyIndia, NGCC, © OpenStreetMap contributors, and the GIS User Community © 2016 Microsoft Corporation © 2010 NAVTEQ © AND





**Sycamore to Peñasquitos
230kV Transmission
Line Project
SWPPP Detail Map
Sheet 55 of 68**

- DRAFT**
- Tracking Control
 - Flow Direction
 - Silt Fence
 - Fiber Roll
 - Storm Drain Inlet Protection
 - Streams & Rivers
- Project Features**
- Entrance Point
 - Project Overhead TL
 - Project Underground TL
 - Access Road
 - Underground Vault
 - Potential Staging Yards
 - Temporary Work Area
 - Permanent Impact

Notes:
Locations of perimeter control BMPs are not to scale. BMP locations are conceptual in nature and must be field-verified prior to construction. Protect all inlets where applicable. Staging yards may be active during any time of construction.

SDG&E is providing this map with the understanding that the map is not survey grade. Certain technology used under license from AT&T Intellectual Property I, L.P. Copyright ©1998 – 2007 AT&T Intellectual Property 1, L.P. All Rights Reserved.

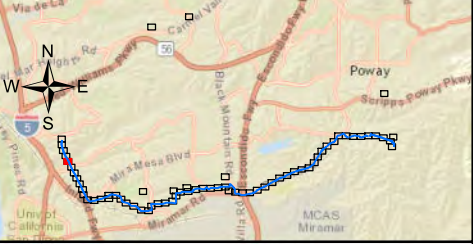
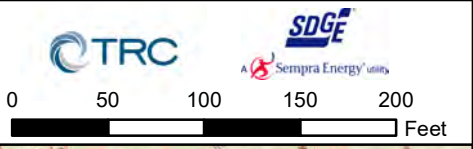

Service Layer Credits: Sources: Esri, HERE, DeLorme, USGS, Intermap, INCREMENT P, NRCan, Esri Japan, METI, Esri China (Hong Kong), Esri Korea, Esri (Thailand), MapmyIndia, NGCC, © OpenStreetMap contributors, and the GIS User Community © 2016 Microsoft Corporation © 2010 NAVTEQ © AND



Los Peñasquitos Creek



**Sycamore to Peñasquitos
230kV Transmission
Line Project
SWPPP Detail Map
Sheet 56 of 68**

- Tracking Control** **DRAFT**
- Tracking Control
 - Flow Direction
 - Silt Fence
 - Fiber Roll
 - Storm Drain Inlet Protection
 - Streams & Rivers
- Project Features**
- Entrance Point
 - Project Overhead TL
 - Project Underground TL
 - Access Road
 - Underground Vault
 - Potential Staging Yards
 - Temporary Work Area
 - Permanent Impact

Notes:
Locations of perimeter control BMPs are not to scale. BMP locations are conceptual in nature and must be field-verified prior to construction. Protect all inlets where applicable. Staging yards may be active during any time of construction.

SDG&E is providing this map with the understanding that the map is not survey grade. Certain technology used under license from AT&T Intellectual Property I, L.P. Copyright ©1998 – 2007 AT&T Intellectual Property 1, L.P. All Rights Reserved.

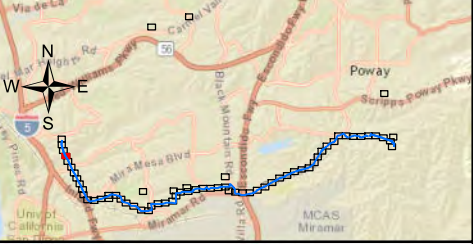
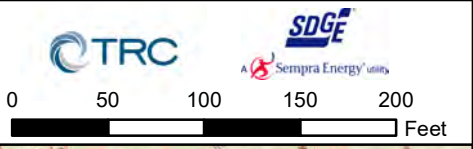







Service Layer Credits: Sources: Esri, HERE, DeLorme, USGS, Intermap, INCREMENT P, NRCan, Esri Japan, METI, Esri China (Hong Kong), Esri Korea, Esri (Thailand), MapmyIndia, NGCC, © OpenStreetMap contributors, and the GIS User Community © 2016 Microsoft Corporation © 2010 NAVTEQ © AND

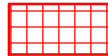









**Sycamore to Peñasquitos
230kV Transmission
Line Project
SWPPP Detail Map
Sheet 57 of 68**

DRAFT

-  Tracking Control
-  Flow Direction
-  Silt Fence
-  Fiber Roll
-  Storm Drain Inlet Protection
-  Streams & Rivers

Project Features

-  Entrance Point
-  Project Overhead TL
-  Project Underground TL
-  Access Road
-  Underground Vault
-  Potential Staging Yards
-  Temporary Work Area
-  Permanent Impact

Notes:
Locations of perimeter control BMPs are not to scale. BMP locations are conceptual in nature and must be field-verified prior to construction. Protect all inlets where applicable. Staging yards may be active during any time of construction.

SDG&E is providing this map with the understanding that the map is not survey grade. Certain technology used under license from AT&T Intellectual Property I, L.P. Copyright ©1998 – 2007 AT&T Intellectual Property 1, L.P. All Rights Reserved.

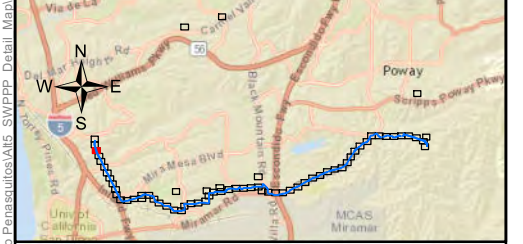
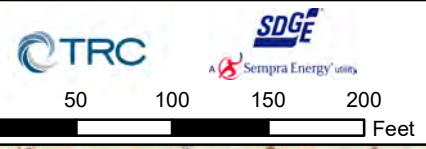



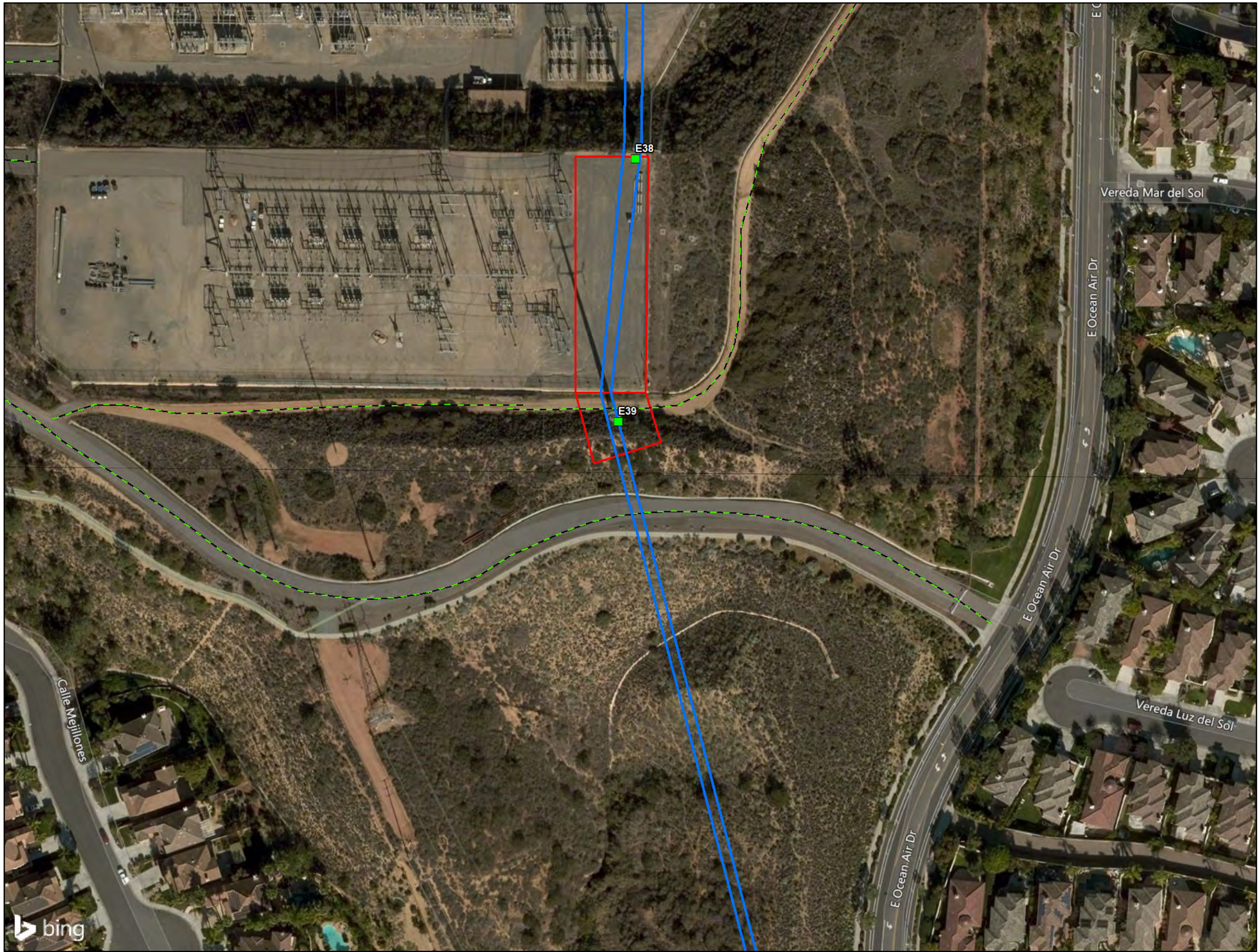



Service Layer Credits: Sources: Esri, HERE, DeLorme, USGS, Intermap, INCREMENT P, NRCan, Esri Japan, METI, Esri China (Hong Kong), Esri Korea, Esri (Thailand), MapmyIndia, NGCC, © OpenStreetMap contributors, and the GIS User Community © 2016 Microsoft Corporation © 2010 NAVTEQ © AND

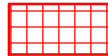









**Sycamore to Peñasquitos
230kV Transmission
Line Project
SWPPP Detail Map
Sheet 58 of 68**

DRAFT

-  Tracking Control
-  Flow Direction
-  Silt Fence
-  Fiber Roll
-  Storm Drain Inlet Protection
-  Streams & Rivers

Project Features

-  Entrance Point
-  Project Overhead TL
-  Project Underground TL
-  Access Road
-  Underground Vault
-  Potential Staging Yards
-  Temporary Work Area
-  Permanent Impact

Notes:
Locations of perimeter control BMPs are not to scale. BMP locations are conceptual in nature and must be field-verified prior to construction. Protect all inlets where applicable. Staging yards may be active during any time of construction.



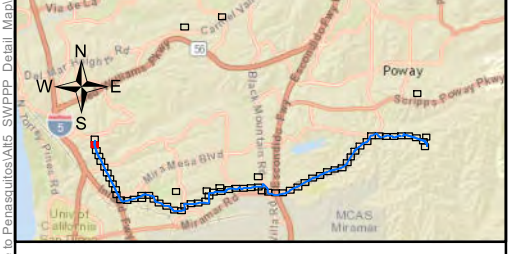
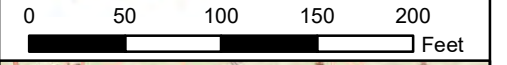







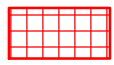



SDG&E is providing this map with the understanding that the map is not survey grade. Certain technology used under license from AT&T Intellectual Property I, L.P. Copyright ©1998 – 2007 AT&T Intellectual Property 1, L.P. All Rights Reserved.



Service Layer Credits: Sources: Esri, HERE, DeLorme, USGS, Intermap, INCREMENT P, NRCan, Esri Japan, METI, Esri China (Hong Kong), Esri Korea, Esri (Thailand), MapmyIndia, NGCC, © OpenStreetMap contributors, and the GIS User Community © 2016 Microsoft Corporation © 2010 NAVTEQ © AND



**Sycamore to Peñasquitos
230kV Transmission
Line Project
SWPPP Detail Map
Sheet 59 of 68**

- DRAFT**
-  Tracking Control
 -  Flow Direction
 -  Silt Fence
 -  Fiber Roll
 -  Storm Drain Inlet Protection
 -  Streams & Rivers
- Project Features**
-  Entrance Point
 -  Project Overhead TL
 -  Project Underground TL
 -  Access Road
 -  Underground Vault
 -  Potential Staging Yards
 -  Temporary Work Area
 -  Permanent Impact

Notes:
Locations of perimeter control BMPs are not to scale. BMP locations are conceptual in nature and must be field-verified prior to construction. Protect all inlets where applicable. Staging yards may be active during any time of construction.

SDG&E is providing this map with the understanding that the map is not survey grade. Certain technology used under license from AT&T Intellectual Property I, L.P. Copyright ©1998 – 2007 AT&T Intellectual Property 1, L.P. All Rights Reserved.

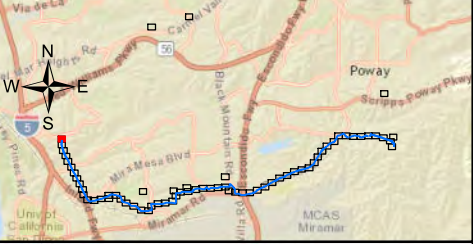
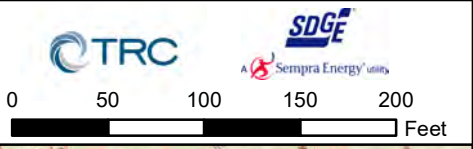



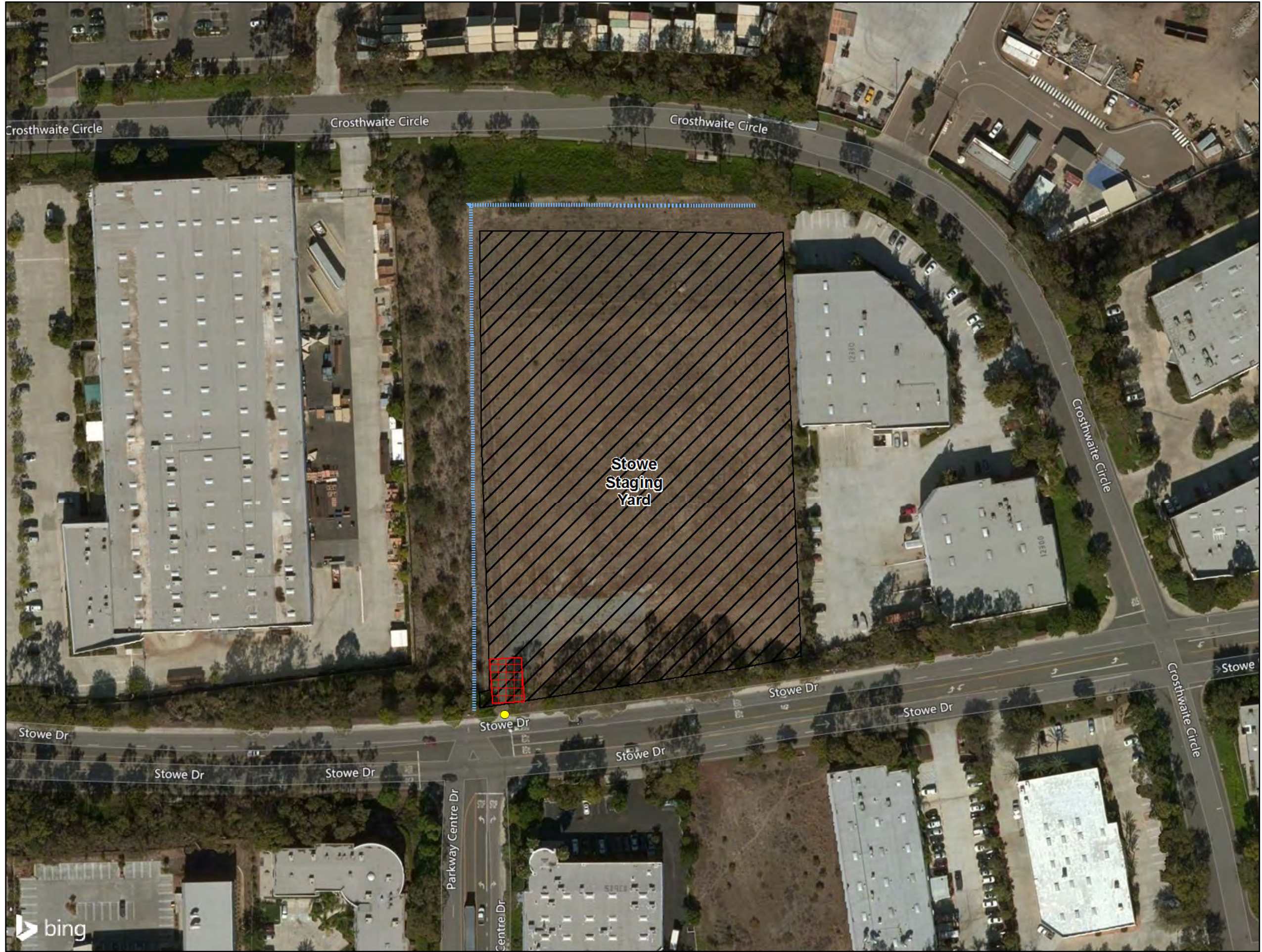











Service Layer Credits: Sources: Esri, HERE, DeLorme, USGS, Intermap, INCREMENT P, NRCan, Esri Japan, METI, Esri China (Hong Kong), Esri Korea, Esri (Thailand), MapmyIndia, NGCC, © OpenStreetMap contributors, and the GIS User Community © 2016 Microsoft Corporation © 2010 NAVTEQ © AND



**Sycamore to Peñasquitos
230kV Transmission
Line Project
SWPPP Detail Map
Sheet 60 of 68**

DRAFT

-  Tracking Control
 -  Flow Direction
 -  Silt Fence
 -  Fiber Roll
 -  Storm Drain Inlet Protection
 -  Streams & Rivers
- Project Features**
-  Entrance Point
 -  Project Overhead TL
 -  Project Underground TL
 -  Access Road
 -  Underground Vault
 -  Potential Staging Yards
 -  Temporary Work Area
 -  Permanent Impact

Notes:
Locations of perimeter control BMPs are not to scale. BMP locations are conceptual in nature and must be field-verified prior to construction. Protect all inlets where applicable. Staging yards may be active during any time of construction.



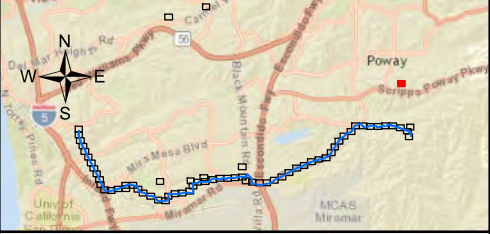
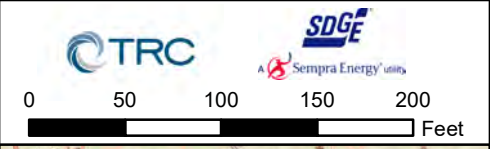







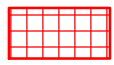



SDG&E is providing this map with the understanding that the map is not survey grade. Certain technology used under license from AT&T Intellectual Property L.P. Copyright ©1998 – 2007 AT&T Intellectual Property 1, L.P. All Rights Reserved.



Service Layer Credits: Sources: Esri, HERE, DeLorme, USGS, Intermap, INCREMENT P, NRCan, Esri Japan, METI, Esri China (Hong Kong), Esri Korea, Esri (Thailand), MapmyIndia, NGCC, © OpenStreetMap contributors, and the GIS User Community © 2016 Microsoft Corporation © 2010 NAVTEQ © AND



**Sycamore to Peñasquitos
230kV Transmission
Line Project
SWPPP Detail Map
Sheet 61 of 68**

- DRAFT**
-  Tracking Control
 -  Flow Direction
 -  Silt Fence
 -  Fiber Roll
 -  Storm Drain Inlet Protection
 -  Streams & Rivers
- Project Features**
-  Entrance Point
 -  Project Overhead TL
 -  Project Underground TL
 -  Access Road
 -  Underground Vault
 -  Potential Staging Yards
 -  Temporary Work Area
 -  Permanent Impact

Notes:
Locations of perimeter control BMPs are not to scale. BMP locations are conceptual in nature and must be field-verified prior to construction. Protect all inlets where applicable. Staging yards may be active during any time of construction.

SDG&E is providing this map with the understanding that the map is not survey grade. Certain technology used under license from AT&T Intellectual Property I, L.P. Copyright ©1998 – 2007 AT&T Intellectual Property 1, L.P. All Rights Reserved.

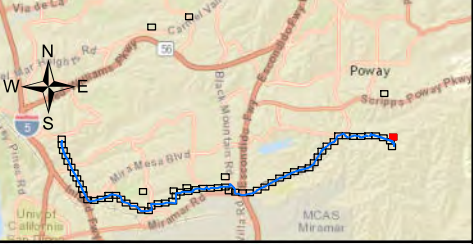
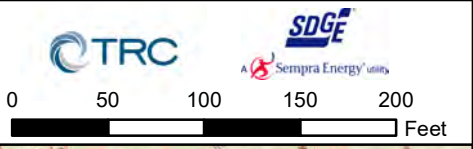

Service Layer Credits: Sources: Esri, HERE, DeLorme, USGS, Intermap, INCREMENT P, NRCan, Esri Japan, METI, Esri China (Hong Kong), Esri Korea, Esri (Thailand), MapmyIndia, NGCC, © OpenStreetMap contributors, and the GIS User Community © 2016 Microsoft Corporation © 2010 NAVTEQ © AND





**Sycamore to Peñasquitos
230kV Transmission
Line Project
SWPPP Detail Map
Sheet 62 of 68**

DRAFT

-  Tracking Control
 -  Flow Direction
 -  Silt Fence
 -  Fiber Roll
 -  Storm Drain Inlet Protection
 -  Streams & Rivers
- Project Features**
-  Entrance Point
 -  Project Overhead TL
 -  Project Underground TL
 -  Access Road
 -  Underground Vault
 -  Potential Staging Yards
 -  Temporary Work Area
 -  Permanent Impact

Notes:
Locations of perimeter control BMPs are not to scale. BMP locations are conceptual in nature and must be field-verified prior to construction. Protect all inlets where applicable. Staging yards may be active during any time of construction.

SDG&E is providing this map with the understanding that the map is not survey grade. Certain technology used under license from AT&T Intellectual Property I, L.P. Copyright ©1998 – 2007 AT&T Intellectual Property 1, L.P. All Rights Reserved.

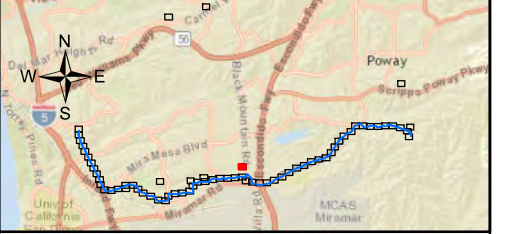
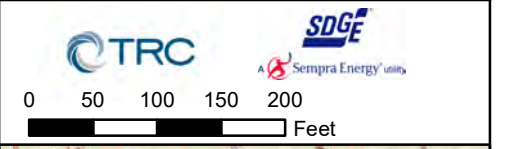

Service Layer Credits: Sources: Esri, HERE, DeLorme, USGS, Intermap, INCREMENT P, NRCan, Esri Japan, METI, Esri China (Hong Kong), Esri Korea, Esri (Thailand), MapmyIndia, NGCC, © OpenStreetMap contributors, and the GIS User Community © 2016 Microsoft Corporation © 2010 NAVTEQ © AND

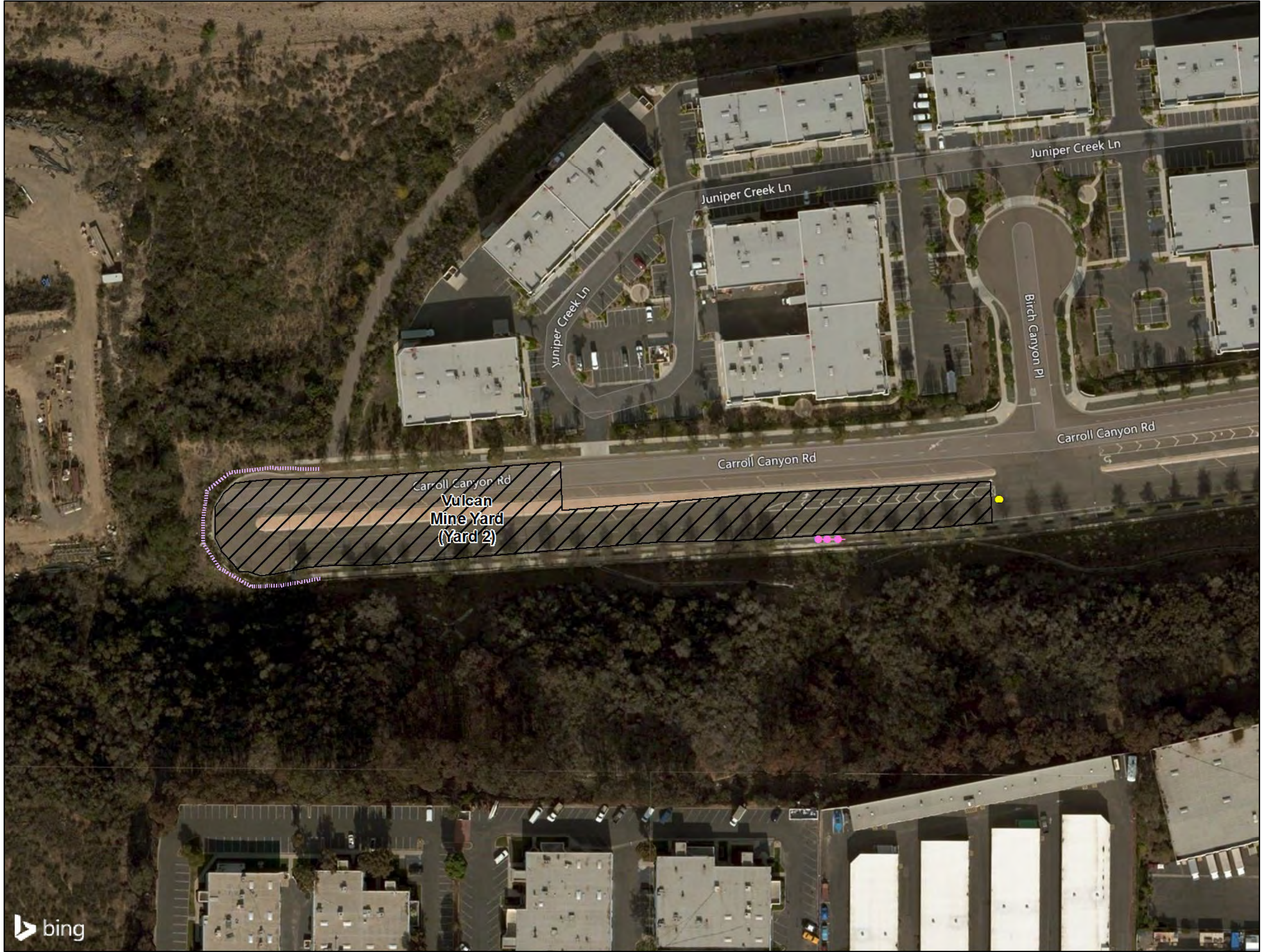

**Sycamore to Peñasquitos
230kV Transmission
Line Project
SWPPP Detail Map
Sheet 63 of 68**

DRAFT

-  Tracking Control
-  Flow Direction
-  Silt Fence
-  Fiber Roll
-  Storm Drain Inlet Protection
-  Streams & Rivers
- Project Features**
-  Entrance Point
-  Project Overhead TL
-  Project Underground TL
-  Access Road
-  Underground Vault
-  Potential Staging Yards
-  Temporary Work Area
-  Permanent Impact

Notes:
Locations of perimeter control BMPs are not to scale. BMP locations are conceptual in nature and must be field-verified prior to construction. Protect all inlets where applicable. Staging yards may be active during any time of construction.



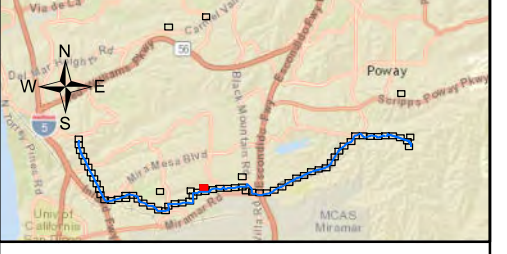
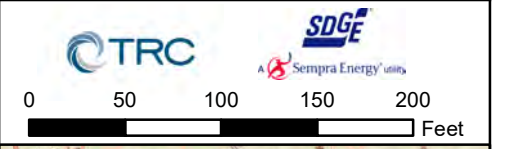







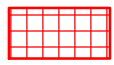



SDG&E is providing this map with the understanding that the map is not survey grade. Certain technology used under license from AT&T Intellectual Property I, L.P. Copyright ©1998 – 2007 AT&T Intellectual Property 1, L.P. All Rights Reserved.



Service Layer Credits: Sources: Esri, HERE, DeLorme, USGS, Intermap, INCREMENT P, NRCan, Esri Japan, METI, Esri China (Hong Kong), Esri Korea, Esri (Thailand), MapmyIndia, NGCC, OpenStreetMap contributors, and the GIS User Community © 2016 Microsoft Corporation © 2010 NAVTEQ © AND



**Sycamore to Peñasquitos
230kV Transmission
Line Project
SWPPP Detail Map
Sheet 64 of 68**

- DRAFT**
-  Tracking Control
 -  Flow Direction
 -  Silt Fence
 -  Fiber Roll
 -  Storm Drain Inlet Protection
 -  Streams & Rivers
- Project Features**
-  Entrance Point
 -  Project Overhead TL
 -  Project Underground TL
 -  Access Road
 -  Underground Vault
 -  Potential Staging Yards
 -  Temporary Work Area
 -  Permanent Impact

Notes:
Locations of perimeter control BMPs are not to scale. BMP locations are conceptual in nature and must be field-verified prior to construction. Protect all inlets where applicable. Staging yards may be active during any time of construction.



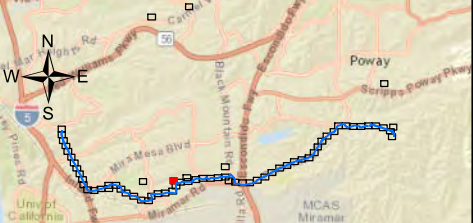
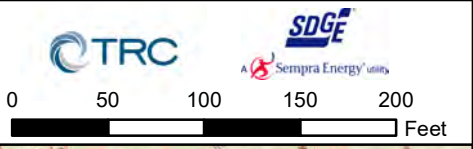







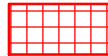



SDG&E is providing this map with the understanding that the map is not survey grade. Certain technology used under license from AT&T Intellectual Property I, L.P. Copyright ©1998 – 2007 AT&T Intellectual Property 1, L.P. All Rights Reserved.

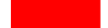

Service Layer Credits: Sources: Esri, HERE, DeLorme, USGS, Intermap, INCREMENT P, NRCan, Esri Japan, METI, Esri China (Hong Kong), Esri Korea, Esri (Thailand), MapmyIndia, NGCC, © OpenStreetMap contributors, and the GIS User Community © 2016 Microsoft Corporation © 2010 NAVTEQ © AND

**Sycamore to Peñasquitos
230kV Transmission
Line Project
SWPPP Detail Map
Sheet 65 of 68**

DRAFT

-  Tracking Control
 -  Flow Direction
 -  Silt Fence
 -  Fiber Roll
 -  Storm Drain Inlet Protection
 -  Streams & Rivers
- Project Features**
-  Entrance Point
 -  Project Overhead TL
 -  Project Underground TL
 -  Access Road
 -  Underground Vault
 -  Potential Staging Yards
 -  Temporary Work Area
 -  Permanent Impact

Notes:
Locations of perimeter control BMPs are not to scale. BMP locations are conceptual in nature and must be field-verified prior to construction. Protect all inlets where applicable. Staging yards may be active during any time of construction.

SDG&E is providing this map with the understanding that the map is not survey grade. Certain technology used under license from AT&T Intellectual Property I, L.P. Copyright ©1998 – 2007 AT&T Intellectual Property 1, L.P. All Rights Reserved.

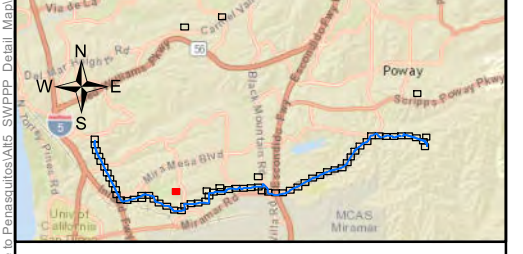
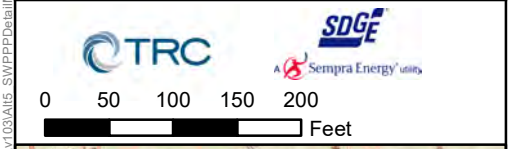

Service Layer Credits: Sources: Esri, HERE, DeLorme, USGS, Intermap, INCREMENT P, NRCan, Esri Japan, METI, Esri China (Hong Kong), Esri Korea, Esri (Thailand), MapmyIndia, NGCC, © OpenStreetMap contributors, and the GIS User Community © 2016 Microsoft Corporation © 2010 NAVTEQ © AND

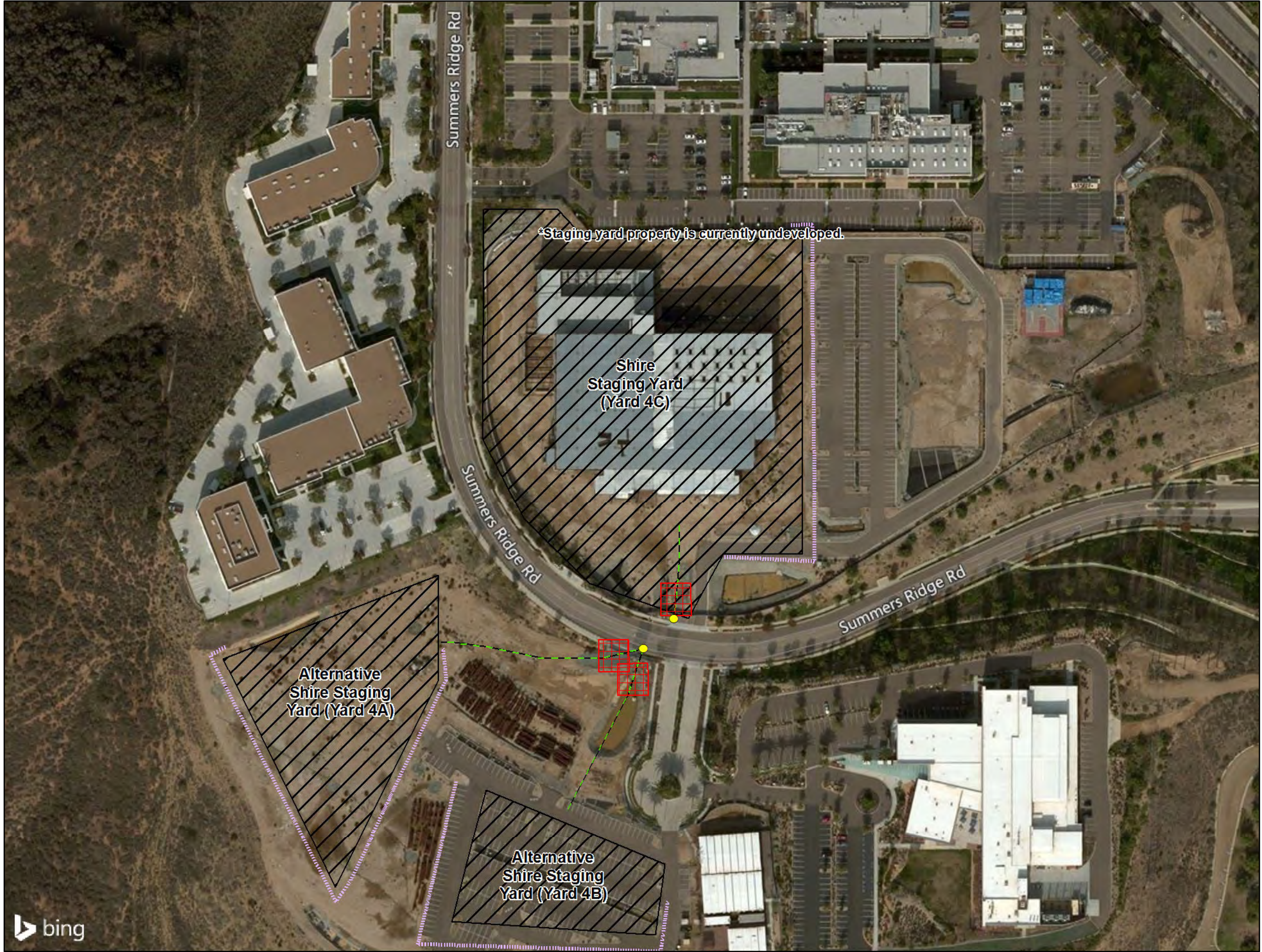



**Sycamore to Peñasquitos
230kV Transmission
Line Project
SWPPP Detail Map
Sheet 66 of 68**

DRAFT

-  Tracking Control
 -  Flow Direction
 -  Silt Fence
 -  Fiber Roll
 -  Storm Drain Inlet Protection
 -  Streams & Rivers
- Project Features**
-  Entrance Point
 -  Project Overhead TL
 -  Project Underground TL
 -  Access Road
 -  Underground Vault
 -  Potential Staging Yards
 -  Temporary Work Area
 -  Permanent Impact

Notes:
Locations of perimeter control BMPs are not to scale. BMP locations are conceptual in nature and must be field-verified prior to construction. Protect all inlets where applicable. Staging yards may be active during any time of construction.

SDG&E is providing this map with the understanding that the map is not survey grade. Certain technology used under license from AT&T Intellectual Property I, L.P. Copyright ©1998 – 2007 AT&T Intellectual Property 1, L.P. All Rights Reserved.

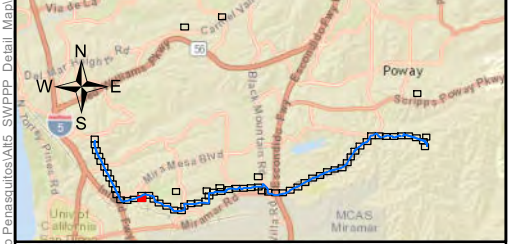
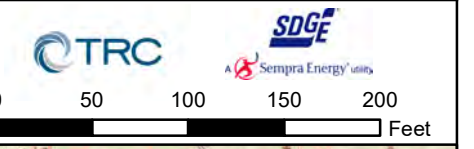

Service Layer Credits: Sources: Esri, HERE, DeLorme, USGS, Intermap, INCREMENT P, NRCan, Esri Japan, METI, Esri China (Hong Kong), Esri Korea, Esri (Thailand), MapmyIndia, NGCC, © OpenStreetMap contributors, and the GIS User Community © 2016 Microsoft Corporation © 2010 NAVTEQ © AND



Mountain Open Space

Black Mountain Open Space

Camino del Sur

Camino del Sur

Carmel Valley Staging Yard







Camino del Sur

Carmel Valley Rd









Carmel Valley

**Sycamore to Peñasquitos
230kV Transmission
Line Project
SWPPP Detail Map
Sheet 67 of 68**

DRAFT

-  Tracking Control
-  Flow Direction
-  Silt Fence
-  Fiber Roll
-  Storm Drain Inlet Protection
-  Streams & Rivers

Project Features

-  Entrance Point
-  Project Overhead TL
-  Project Underground TL
-  Access Road
-  Underground Vault
-  Potential Staging Yards
-  Temporary Work Area
-  Permanent Impact

Notes:
Locations of perimeter control BMPs are not to scale. BMP locations are conceptual in nature and must be field-verified prior to construction. Protect all inlets where applicable. Staging yards may be active during any time of construction.

SDG&E is providing this map with the understanding that the map is not survey grade. Certain technology used under license from AT&T Intellectual Property I, L.P. Copyright ©1998 – 2007 AT&T Intellectual Property 1, L.P. All Rights Reserved.

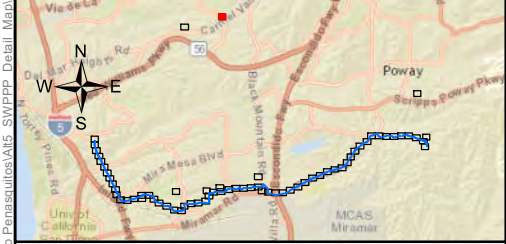
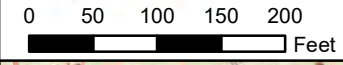

Service Layer Credits: Sources: Esri, HERE, DeLorme, USGS, Intermap, INCREMENT P, NRCan, Esri Japan, METI, Esri China (Hong Kong), Esri Korea, Esri (Thailand), MapmyIndia, NGCC, © OpenStreetMap contributors, and the GIS User Community © 2016 Microsoft Corporation © 2010 NAVTEQ © AND

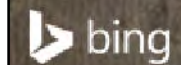



**Sycamore to Peñasquitos
230kV Transmission
Line Project
SWPPP Detail Map
Sheet 68 of 68**

- DRAFT**
- Tracking Control
 - Flow Direction
 - Silt Fence
 - Fiber Roll
 - Storm Drain Inlet Protection
 - Streams & Rivers
- Project Features**
- Entrance Point
 - Project Overhead TL
 - Project Underground TL
 - Access Road
 - Underground Vault
 - Potential Staging Yards
 - Temporary Work Area
 - Permanent Impact

Notes:
Locations of perimeter control BMPs are not to scale. BMP locations are conceptual in nature and must be field-verified prior to construction. Protect all inlets where applicable. Staging yards may be active during any time of construction.

SDG&E is providing this map with the understanding that the map is not survey grade. Certain technology used under license from AT&T Intellectual Property I, L.P. Copyright ©1998 – 2007 AT&T Intellectual Property 1, L.P. All Rights Reserved.

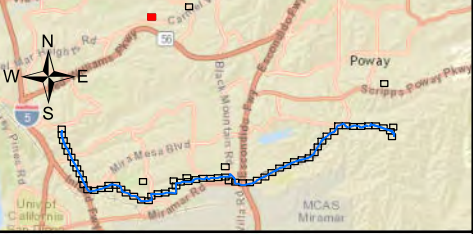

Service Layer Credits: Image courtesy of USGS © 2016 Microsoft Corporation © 2010 NAVTEQ © AND Sources: Esri, HERE, DeLorme, USGS, Intermap, INCREMENT P, NRCan, Esri Japan, METI, Esri China (Hong Kong), Esri Korea, Esri (Thailand), MapmyIndia, NGCC, © OpenStreetMap contributors, and the GIS User Community

APPENDIX IV
CALCULATIONS/ANALYSES/BACKGROUND INFORMATION

Segment Locations

Segment 1

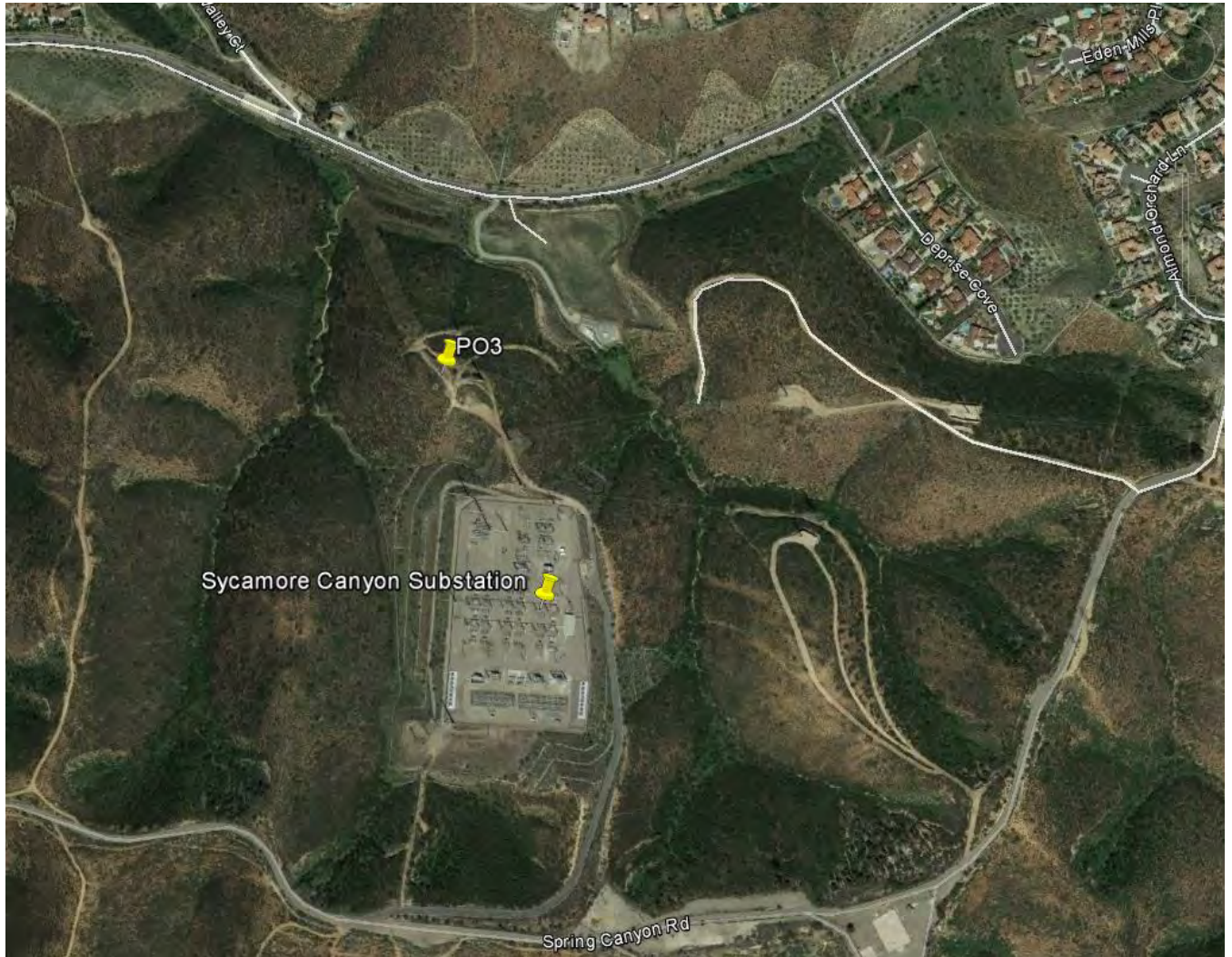

PO3 (End Point):



Segment 2

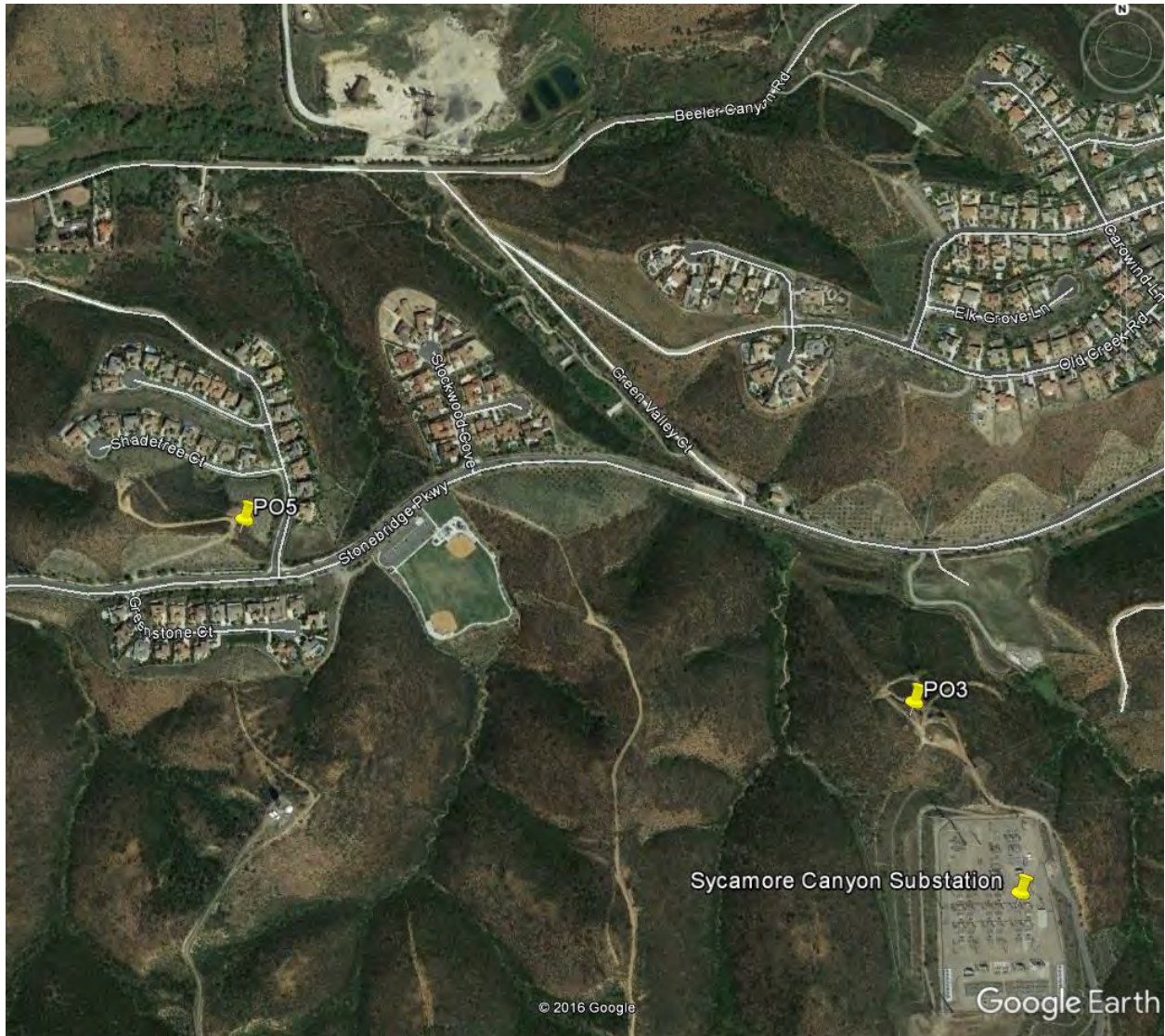

PO5 (End Point):

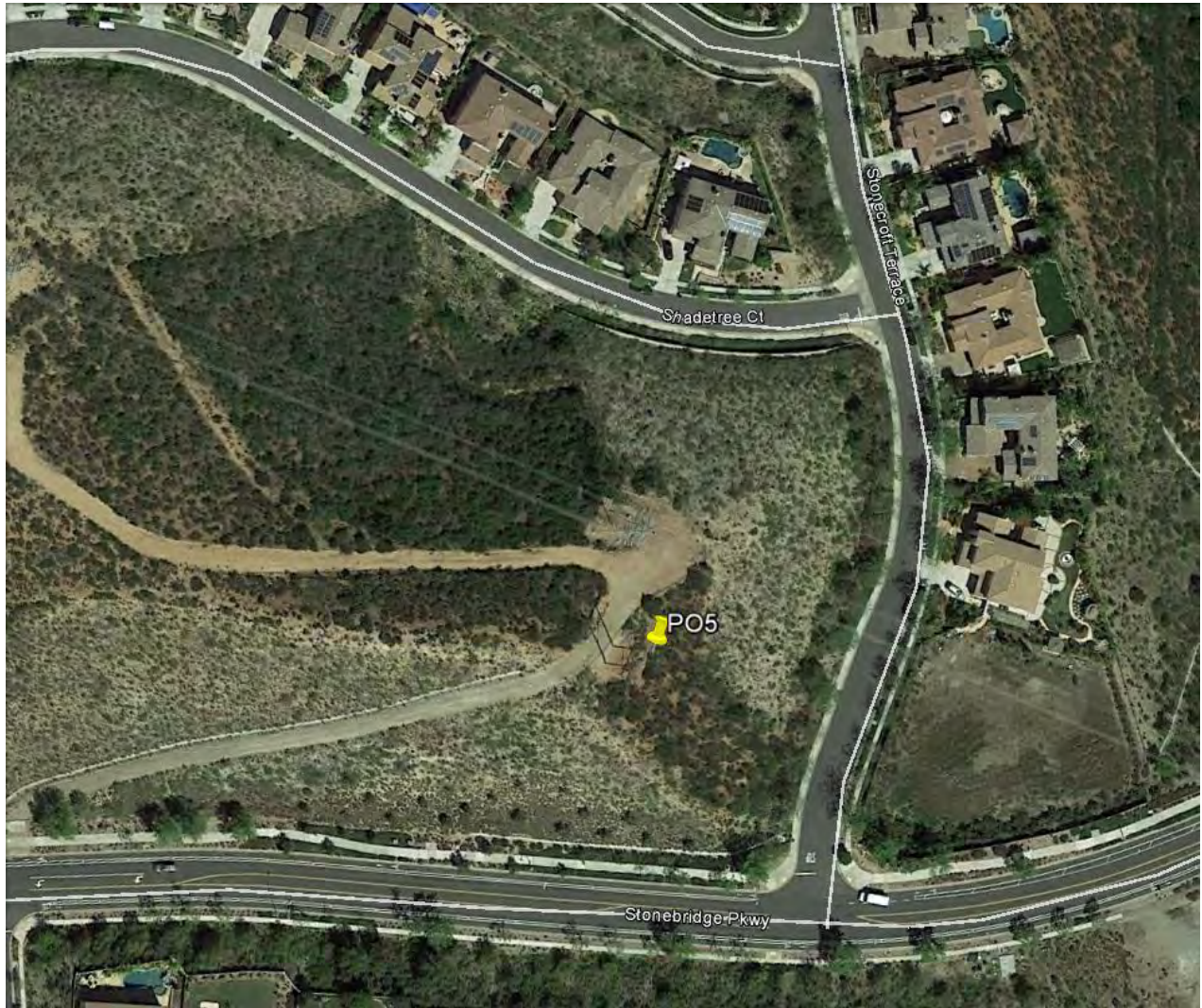

Segment 3

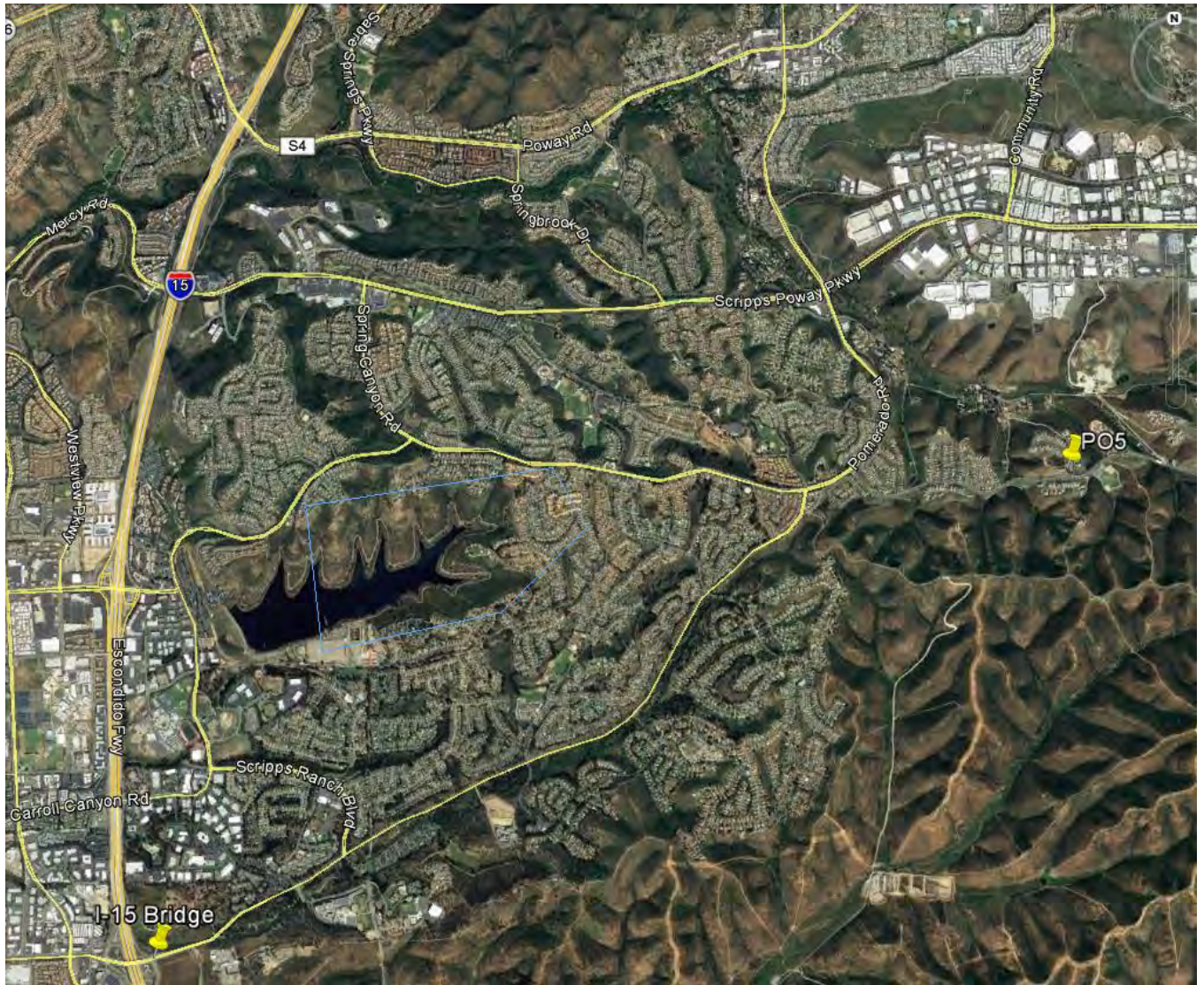

1-15 Bridge (End Point):

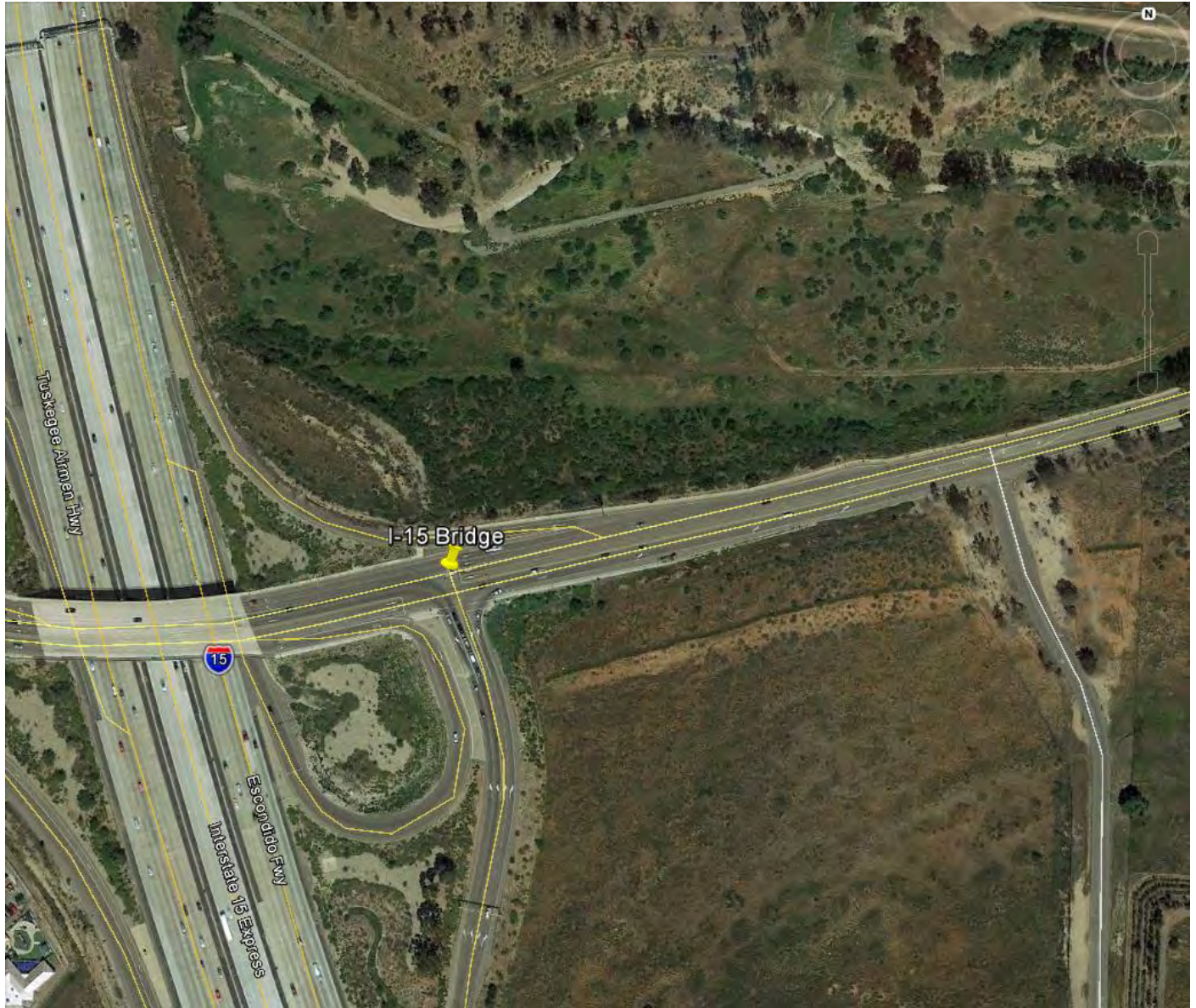

Segment 4:



Segment 5:



Carroll Canyon (End Point):

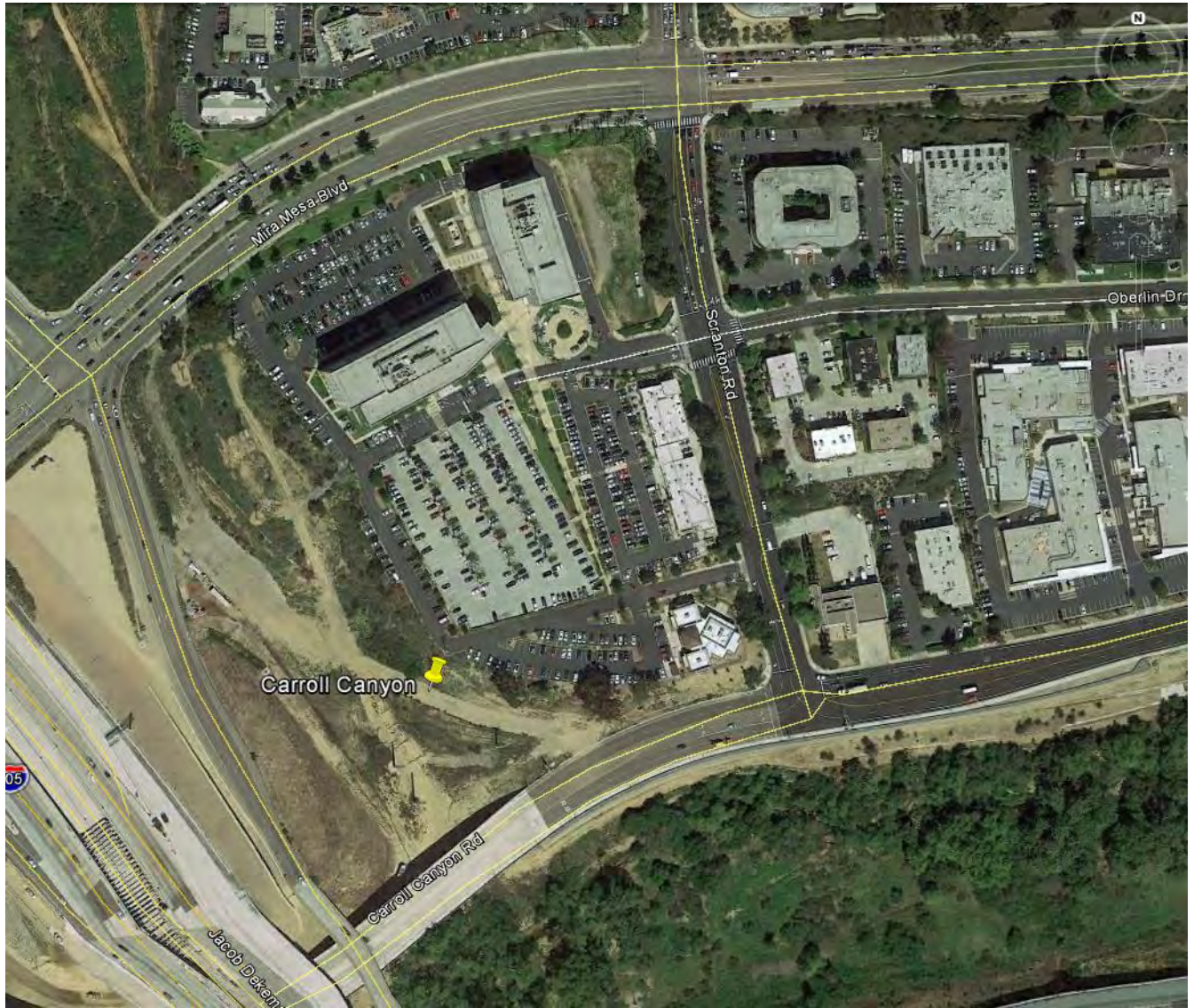

Segment 6:



Coast Zone Boundary (End Point):



Segment 7:

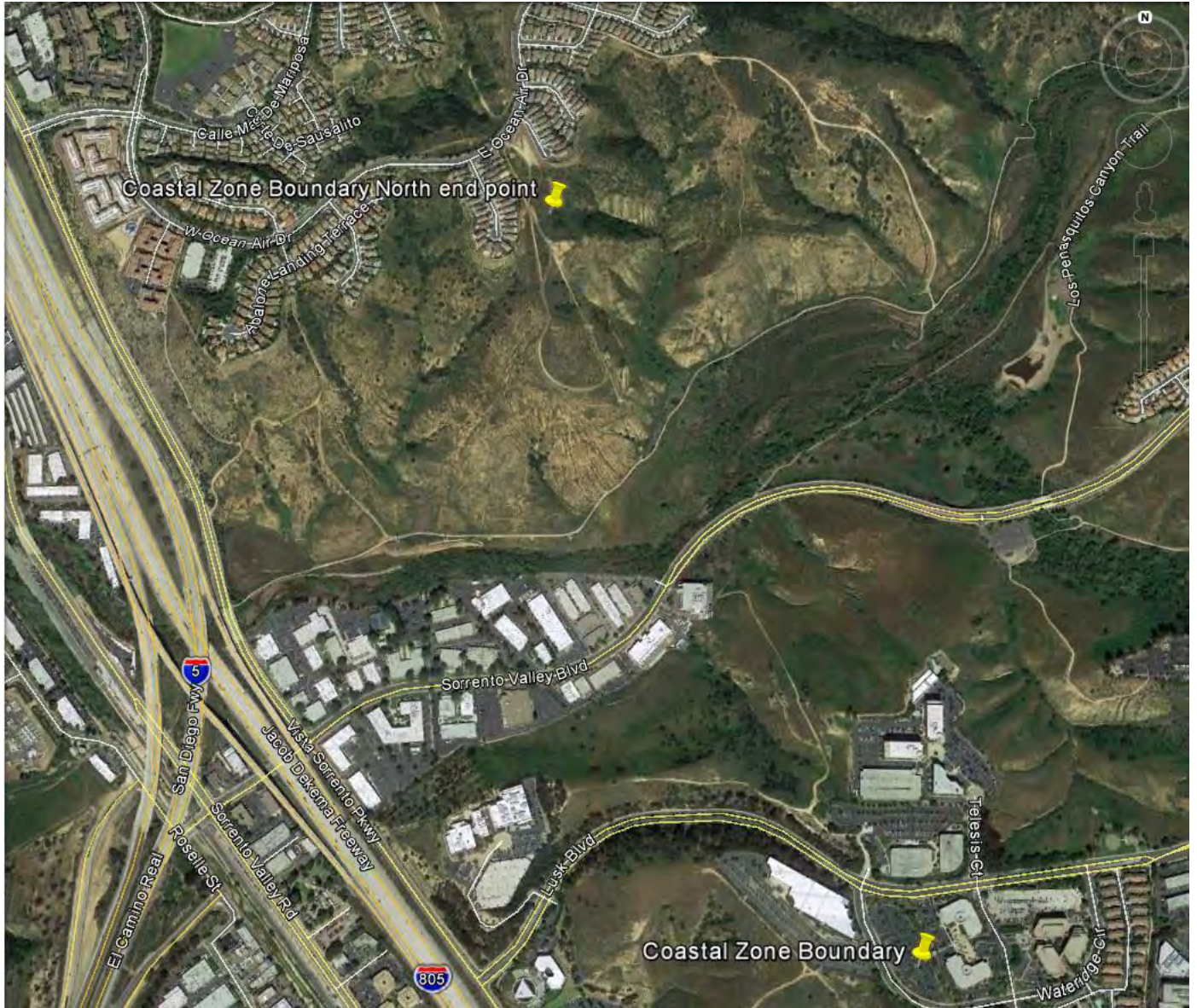

Coastal Zone Boundary North End Point:



Segment 8:

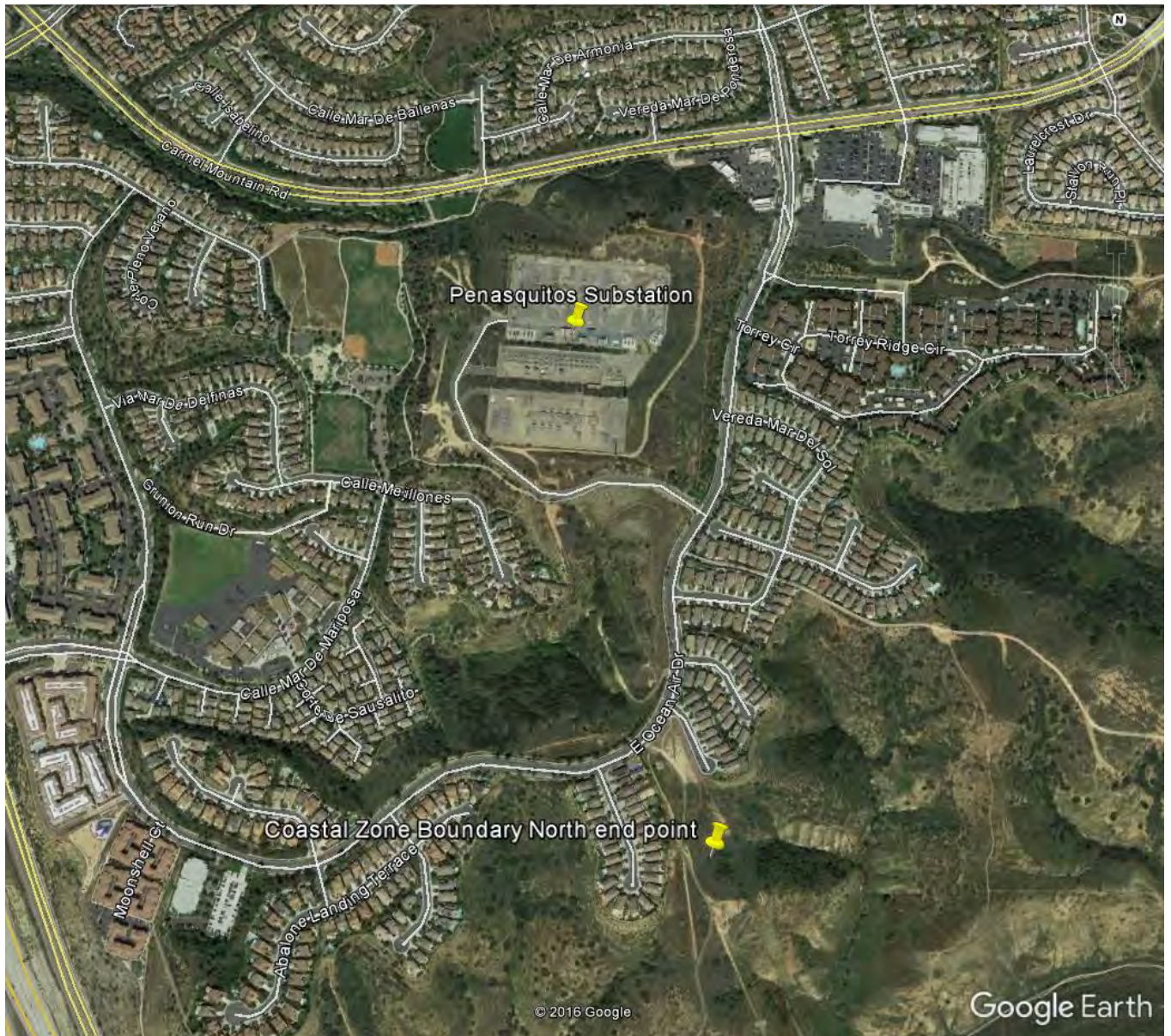

Risk Type Determination

Segment 1A:

Facility Information

- Start Date: 02/15/2017
- End Date: 03/15/2017
- Latitude: 32.9185
- Longitude: -117.0314

Erosivity Index Calculator Results

An erosivity index value of **6.49** has been determined for the construction period of **02/15/2017 - 03/15/2017**.

A rainfall erosivity factor of 5.0 or greater has been calculated for your site and period of construction. **You do NOT qualify for a waiver from NPDES permitting requirements.**

Owner Info Developer Info Site Info Segments Info **Risk** Addtl Site Info Billing Info Attachments Certification Inspections Print Status History Linked Users NOTs COIs

SEGMENT NAME: Segment 1

Will >= 70% of the construction activity occur on paved surfaces/Will < 30% of the soil disturbance occur on unpaved surfaces?

Will the construction activity occur on unpaved improved roads, including their shoulders or land immediately adjacent to them?

Will areas disturbed be returned to preconstruction conditions or equivalent condition* at the end of the day?

SEDIMENT RISK FACTOR WORKSHEET	
Instructions: Enter R,K and LS factor values. System will calculate watershed erosion estimates and site sediment risk factor	
A. Sediment Risk	
A) R Factor Value: (What's this?)	6.49 <input type="button" value="Erosivity Calculator"/>
B) K Factor Value (weighted average, by area, for all site soils) (What's this?) ***If not using the SWRCB map(Populate K Factor) upload your analysis on the Attachment Tab prior to submitting to the SWRCB.	0.2 <input type="button" value="Populate K Factor"/>
C) LS Factor (weighted average, by area, for all slopes) (What's this?) ***If not using the SWRCB map(Populate LS Factor) upload your analysis on the Attachment Tab prior to submitting to the SWRCB.	5.18830872 <input type="button" value="Populate LS Factor"/>
Watershed Erosion Estimate (=R*K*LS) in tons/acre	
	6.73442471856
Site Sediment Risk Factor	
Low Sediment Risk: < 15 tons/acre Medium Sediment Risk: >= 15 and <75 tons/acre High Sediment Risk: >= 75 tons/acre	
	Low

RECEIVING WATER (RW) RISK FACTOR WORKSHEET

Is the project area or project section area located within a Sediment Sensitive Watershed?

[Statewide Map of High Receiving Water Risk Watersheds](#)

Low

C. Combined Risk Level Matrix

		Sediment Risk		
		Low	Medium	High
Receiving Water Risk	Low	Type1	Type2	Type3
	Medium	Type1	Type2	Type3
	High	Type2	Type3	Type3

Segment Sediment Risk:

Segment Receiving Water Risk:

Segment Combined Risk:

Segment 2A:

Facility Information

- Start Date: 01/15/2017
- End Date: 03/15/2017
- Latitude: 32.9211
- Longitude: -117.0373

Erosivity Index Calculator Results

An erosivity index value Of **14.53** has been determined for the construction period of **01/15/2017 - 03/15/2017**.

A rainfall erosivity factor of 5.0 or greater has been calculated for your site and period of construction. **You do NOT qualify for a waiver from NPDES permitting requirements.**

SEGMENT NAME: Segment 2												
Will \geq 70% of the construction activity occur on paved surfaces/Will $<$ 30% of the soil disturbance occur on unpaved surfaces?	No											
Will the construction activity occur on unpaved improved roads, including their shoulders or land immediately adjacent to them?	Yes											
Will areas disturbed be returned to preconstruction conditions or equivalent condition* at the end of the day?	No											
SEDIMENT RISK FACTOR WORK SHEET Instructions: Enter R,K and LS factor values. System will calculate watershed erosion estimates and site sediment risk factor A. Sediment Risk												
A) R Factor Value: (What's this?)	14.53 Erosivity Calculator											
B) K Factor Value (weighted average, by area, for all site soils) (What's this?) ***If not using the SWRCB map(Populate K Factor) upload your analysis on the Attachment Tab prior to submitting to the SWRCB.	0.2 Populate K Factor											
C) LS Factor (weighted average, by area, for all slopes) (What's this?) ***If not using the SWRCB map(Populate LS Factor) upload your analysis on the Attachment Tab prior to submitting to the SWRCB.	5.18830872 Populate LS Factor											
Watershed Erosion Estimate (=R*K*LS) in tons/acre												
15.07722514032												
Site Sediment Risk Factor Low Sediment Risk: $<$ 15 tons/acre Medium Sediment Risk: \geq 15 and $<$ 75 tons/acre High Sediment Risk: \geq 75 tons/acre												
Medium												
RECEIVING WATER (RW) RISK FACTOR WORKSHEET												
Is the project area or project section area located within a Sediment Sensitive Watershed*?	Populate Receiving Water Risk No											
	Statewide Map of High Receiving Water Risk Watersheds											
	LOW											
C. Combined Risk Level Matrix												
	Sediment Risk											
	Low Medium High											
Receiving Water Risk	<table border="1"> <tr> <td>Low</td> <td>Type1</td> <td>Type2</td> </tr> <tr> <td>Medium</td> <td>Type1</td> <td>Type2</td> <td>Type3</td> </tr> <tr> <td>High</td> <td>Type2</td> <td colspan="2">Type3</td> </tr> </table>	Low	Type1	Type2	Medium	Type1	Type2	Type3	High	Type2	Type3	
Low	Type1	Type2										
Medium	Type1	Type2	Type3									
High	Type2	Type3										
Segment Sediment Risk:	Medium											
Segment Receiving Water Risk:	Low											
Segment Combined Risk:	Type1											

Segment 3B:

Facility Information

- Start Date: 01/15/2017
- End Date: 06/20/2018
- Latitude: 32.9071
- Longitude: -117.0773

Erosivity Index Calculator Results

An erosivity index value Of **56.81** has been determined for the construction period of **01/15/2017 - 06/20/2018**.

A rainfall erosivity factor of 5.0 or greater has been calculated for your site and period of construction. **You do NOT qualify for a waiver from NPDES permitting requirements.**

SEGMENT NAME: Segment 3	
Will \geq 70% of the construction activity occur on paved surfaces/Will $<$ 30% of the soil disturbance occur on unpaved surfaces?	Yes ▾
Will areas disturbed be returned to preconstruction conditions or equivalent condition* at the end of the day?	Yes ▾
SEDIMENT RISK FACTOR WORKSHEET Instructions: Enter R,K and LS factor values. System will calculate watershed erosion estimates and site sediment risk factor	
A. Sediment Risk	
A) R Factor Value: (What's this?)	56.81 * Erosivity Calculator
B) K Factor Value (weighted average, by area, for all site soils) (What's this?) ***If not using the SWRCB map(Populate K Factor) upload your analysis on the Attachment Tab prior to submitting to the SWRCB.	0.2 * Populate K Factor
C) LS Factor (weighted average, by area, for all slopes) (What's this?) ***If not using the SWRCB map(Populate LS Factor) upload your analysis on the Attachment Tab prior to submitting to the SWRCB.	3.67117143 * Populate LS Factor
Watershed Erosion Estimate (=R*K*LS) in tons/acre	
41.71184978766	
Site Sediment Risk Factor Low Sediment Risk: $<$ 15 tons/acre Medium Sediment Risk: \geq 15 and $<$ 75 tons/acre High Sediment Risk: \geq 75 tons/acre	
Medium	

C. Combined Risk Level Matrix

		Sediment Risk		
		Low	Medium	High
Receiving Water Risk	Low	Type1	Type1	Type2
	Medium	Type1	Type2	Type3
	High	Type2	Type3	

Segment Sediment Risk:

Segment Receiving Water Risk:

Segment Combined Risk:

Segment 4B:

Facility Information

- Start Date: 08/17/2017
- End Date: 06/20/2018
- Latitude: 32.8931
- Longitude: -117.1156

Erosivity Index Calculator Results

An erosivity index value Of **34.83** has been determined for the construction period of **08/17/2017 - 06/20/2018**.

A rainfall erosivity factor of 5.0 or greater has been calculated for your site and period of construction. **You do NOT qualify for a waiver from NPDES permitting requirements.**

Owner Info	Developer Info	Site Info	Segments Info	Risk	Add'l Site Info	Billing Info	Attachments	Certification	Inspections	Print	Status History	Linked Users	NOTS	COIs
------------	----------------	-----------	---------------	-------------	-----------------	--------------	-------------	---------------	-------------	-------	----------------	--------------	------	------

SEGMENT NAME: Segment 4

Will >= 70% of the construction activity occur on paved surfaces/Will < 30% of the soil disturbance occur on unpaved surfaces? Yes ▾

Will areas disturbed be returned to preconstruction conditions or equivalent condition* at the end of the day? Yes ▾

SEDIMENT RISK FACTOR WORK SHEET Instructions: Enter R,K and LS factor values. System will calculate watershed erosion estimates and site sediment risk factor	
A. Sediment Risk	
A) R Factor Value: (What's this?)	34.83 * Erosivity Calculator
B) K Factor Value (weighted average, by area, for all site soils) (What's this?) ***If not using the SWRCB map(Populate K Factor) upload your analysis on the Attachment Tab prior to submitting to the SWRCB.	0.24 * Populate K Factor
C) LS Factor (weighted average, by area, for all slopes) (What's this?) ***If not using the SWRCB map(Populate LS Factor) upload your analysis on the Attachment Tab prior to submitting to the SWRCB.	2.23508 * Populate LS Factor
Watershed Erosion Estimate (=R*K*LS) in tons/acre	
18.683480736	
Site Sediment Risk Factor	
Low Sediment Risk: < 15 tons/acre Medium Sediment Risk: >= 15 and <75 tons/acre High Sediment Risk: >= 75 tons/acre	
Medium	

C. Combined Risk Level Matrix

		Sediment Risk		
		Low	Medium	High
Receiving Water Risk	Low	Type1	Type2	Type3
	Medium	Type1	Type2	Type3
	High	Type2	Type3	

Segment Sediment Risk:

Segment Receiving Water Risk:

Segment Combined Risk:

Segment 5B:

Facility Information

- Start Date: 01/15/2017
- End Date: 06/20/2018
- Latitude: 32.8917
- Longitude: -117.1605

Erosivity Index Calculator Results

An erosivity index value Of **53.75** has been determined for the construction period of 01/15/2017 - 06/20/2018.

A rainfall erosivity factor of 5.0 or greater has been calculated for your site and period of construction. **You do NOT qualify for a waiver from NPDES permitting requirements.**

- Owner Info
- Developer Info
- Site Info
- Segments Info
- Risk**
- Add! Site Info
- Billing Info
- Attachments
- Certification
- Inspections
- Print
- Status History
- Linked Users
- NOTs
- COIs

SEGMENT NAME: Segment 5

Will \geq 70% of the construction activity occur on paved surfaces/Will $<$ 30% of the soil disturbance occur on unpaved surfaces? Yes

Will areas disturbed be returned to preconstruction conditions or equivalent condition* at the end of the day? Yes

SEDIMENT RISK FACTOR WORKSHEET
 Instructions: Enter R,K and LS factor values. System will calculate watershed erosion estimates and site sediment risk factor

A. Sediment Risk

A) R Factor Value: [\(What's this?\)](#) 53.75 *
[Erosivity Calculator](#)

B) K Factor Value (weighted average, by area, for all site soils) [\(What's this?\)](#) 0.24 *
 ***If not using the SWRCB map(Populate K Factor) upload your analysis on the Attachment Tab prior to submitting to the SWRCB.

C) LS Factor (weighted average, by area, for all slopes) [\(What's this?\)](#) ***If not using the SWRCB map(Populate LS Factor) upload your analysis on the Attachment Tab prior to submitting to the SWRCB. 2.23508 *

Watershed Erosion Estimate (=R*K*LS) in tons/acre 28.832532000

Site Sediment Risk Factor

Low Sediment Risk: $<$ 15 tons/acre
 Medium Sediment Risk: \geq 15 and $<$ 75 tons/acre
 High Sediment Risk: \geq 75 tons/acre

C. Combined Risk Level Matrix

		Sediment Risk		
		Low	Medium	High
Receiving Water Risk	Low	Type1	Type2	
	Medium	Type1	Type2	Type3
	High	Type2	Type3	

Segment Sediment Risk:

Segment Receiving Water Risk:

Segment Combined Risk:

Segment 6C:

Facility Information

- Start Date: 01/15/2017
- End Date: 05/30/2017
- Latitude: 32.8945
- Longitude: -117.2059

Erosivity Index Calculator Results

An erosivity index value Of **16.73** has been determined for the construction period of **01/15/2017 - 05/30/2017**.

A rainfall erosivity factor of 5.0 or greater has been calculated for your site and period of construction. **You do NOT qualify for a waiver from NPDES permitting requirements.**

Owner Info	Developer Info	Site Info	Segments Info	Risk	Addtl Site Info	Billing Info	Attachments	Certification	Inspections	Print	Status History	Linked Users	NOTs	COIs																					
SEGMENT NAME: Segment 6																																			
Will >= 70% of the construction activity occur on paved surfaces/Will < 30% of the soil disturbance occur on unpaved surfaces?													No																						
Will the construction activity occur on unpaved improved roads, including their shoulders or land immediately adjacent to them?													Yes																						
Will areas disturbed be returned to preconstruction conditions or equivalent condition* at the end of the day?													No																						
SEDIMENT RISK FACTOR WORKSHEET Instructions: Enter R,K and LS factor values. System will calculate watershed erosion estimates and site sediment risk factor A. Sediment Risk																																			
A) R Factor Value: (What's this?)													16.73 *																						
													Erosivity Calculator																						
B) K Factor Value (weighted average, by area, for all site soils) (What's this?) ***If not using the SWRCB map(Populate K Factor) upload your analysis on the Attachment Tab prior to submitting to the SWRCB.													0.43 *																						
													Populate K Factor																						
C) LS Factor (weighted average, by area, for all slopes) (What's this?) ***If not using the SWRCB map(Populate LS Factor) upload your analysis on the Attachment Tab prior to submitting to the SWRCB.													4.34997463 *																						
													Populate LS Factor																						
Watershed Erosion Estimate (=R*K*LS) in tons/acre													31.293282490757																						
Site Sediment Risk Factor													Medium																						
Low Sediment Risk: < 15 tons/acre Medium Sediment Risk: >= 15 and <75 tons/acre High Sediment Risk: >= 75 tons/acre																																			
RECEIVING WATER (RW) RISK FACTOR WORKSHEET																																			
Is the project area or project section area located within a Sediment Sensitive Watershed**?													Populate Receiving Water Risk Yes																						
Is the project area or section located within the flood plain or flood prone area (riparian zone) of a Sensitive Receiving Water Body*?													No																						
													Statewide Map of High Receiving Water Risk Watersheds																						
													Medium																						
C. Combined Risk Level Matrix																																			
<table border="1"> <thead> <tr> <th colspan="2" rowspan="2"></th> <th colspan="3">Sediment Risk</th> </tr> <tr> <th>Low</th> <th>Medium</th> <th>High</th> </tr> </thead> <tbody> <tr> <th rowspan="3">Receiving Water Risk</th> <th>Low</th> <td style="background-color: #e0ffff;">Type1</td> <td></td> <td style="background-color: #ffffe0;">Type2</td> </tr> <tr> <th>Medium</th> <td style="background-color: #e0ffff;">Type1</td> <td style="background-color: #ffffe0;">Type2</td> <td style="background-color: #ffe0e0;">Type3</td> </tr> <tr> <th>High</th> <td style="background-color: #ffffe0;">Type2</td> <td colspan="2" style="background-color: #ffe0e0;">Type3</td> </tr> </tbody> </table>																	Sediment Risk			Low	Medium	High	Receiving Water Risk	Low	Type1		Type2	Medium	Type1	Type2	Type3	High	Type2	Type3	
		Sediment Risk																																	
		Low	Medium	High																															
Receiving Water Risk	Low	Type1		Type2																															
	Medium	Type1	Type2	Type3																															
	High	Type2	Type3																																
Segment Sediment Risk:		Medium																																	
Segment Receiving Water Risk:		Medium																																	
Segment Combined Risk:		Type2																																	

Segment 7C:

Facility Information

- Start Date: 02/15/2017
- End Date: 05/30/2017
- Latitude: 32.9055
- Longitude: -117.2127

Erosivity Index Calculator Results

An erosivity index value Of **9.74** has been determined for the construction period of 02/15/2017 - 05/30/2017.

A rainfall erosivity factor of 5.0 or greater has been calculated for your site and period of construction. You do NOT qualify for a waiver from NPDES permitting requirements.

Owner Info	Developer Info	Site Info	Segments Info	Risk	Addtl Site Info	Billing Info	Attachments	Certification	Inspections	Print	Status History	Linked Users	NOTS	COIs
----------------------------	--------------------------------	---------------------------	-------------------------------	----------------------	---------------------------------	------------------------------	-----------------------------	-------------------------------	-----------------------------	-----------------------	--------------------------------	------------------------------	----------------------	----------------------

SEGMENT NAME: Segment 7

Will >= 70% of the construction activity occur on paved surfaces/Will < 30% of the soil disturbance occur on unpaved surfaces?

Will the construction activity occur on unpaved improved roads, including their shoulders or land immediately adjacent to them?

Will areas disturbed be returned to preconstruction conditions or equivalent condition* at the end of the day?

SEDIMENT RISK FACTOR WORKSHEET
Instructions: Enter R,K and LS factor values. System will calculate watershed erosion estimates and site sediment risk factor

A. Sediment Risk

A) R Factor Value: [\(What's this?\)](#) * [Erosivity Calculator](#)

B) K Factor Value (weighted average, by area, for all site soils) [\(What's this?\)](#) *
***If not using the SWRCB map(Populate K Factor) upload your analysis on the Attachment Tab prior to submitting to the SWRCB.

C) LS Factor (weighted average, by area, for all slopes) [\(What's this?\)](#) ***If not using the SWRCB map(Populate LS Factor) upload your analysis on the Attachment Tab prior to submitting to the SWRCB. *

Watershed Erosion Estimate (=R*K*LS) in tons/acre

Site Sediment Risk Factor
Low Sediment Risk: < 15 tons/acre
Medium Sediment Risk: >= 15 and <75 tons/acre
High Sediment Risk: >= 75 tons/acre

RECEIVING WATER (RW) RISK FACTOR WORKSHEET

Is the project area or project section area located within a Sediment Sensitive Watershed*?

Is the project area or section located within the flood plain or flood prone area (riparian zone) of a Sensitive Receiving Water Body*?

[Statewide Map of High Receiving Water Risk Watersheds](#)

C. Combined Risk Level Matrix

		Sediment Risk		
		Low	Medium	High
Receiving Water Risk	Low	Type1	Type2	Type3
	Medium	Type1	Type2	Type3
	High	Type2	Type3	

Segment Sediment Risk:

Segment Receiving Water Risk:

Segment Combined Risk:

Segment 8C:

Facility Information

- Start Date: 01/15/2017
- End Date: 05/30/2017
- Latitude: 32.915
- Longitude: -117.2179

Erosivity Index Calculator Results

An erosivity index value Of **16.73** has been determined for the construction period of **01/15/2017 - 05/30/2017**.

A rainfall erosivity factor of 5.0 or greater has been calculated for your site and period of construction. **You do NOT qualify for a waiver from NPDES permitting requirements.**

SEGMENT NAME: Segment 8

Will >= 70% of the construction activity occur on paved surfaces/Will < 30% of the soil disturbance occur on unpaved surfaces? No

Will the construction activity occur on unpaved improved roads, including their shoulders or land immediately adjacent to them? Yes

Will areas disturbed be returned to preconstruction conditions or equivalent condition* at the end of the day? No

SEDIMENT RISK FACTOR WORKSHEET
 Instructions: Enter R,K and LS factor values. System will calculate watershed erosion estimates and site sediment risk factor

A. Sediment Risk

A) R Factor Value: [\(What's this?\)](#) * [Erosivity Calculator](#)

B) K Factor Value (weighted average, by area, for all site soils) [\(What's this?\)](#) *
 ***If not using the SWRCB map(Populate K Factor) upload your analysis on the Attachment Tab prior to submitting to the SWRCB.

C) LS Factor (weighted average, by area, for all slopes) [\(What's this?\)](#) ***If not using the SWRCB map(Populate LS Factor) upload your analysis on the Attachment Tab prior to submitting to the SWRCB. *

Watershed Erosion Estimate (=R*K*LS) in tons/acre

Site Sediment Risk Factor
 Low Sediment Risk: < 15 tons/acre
 Medium Sediment Risk: >= 15 and <75 tons/acre
 High Sediment Risk: >= 75 tons/acre

RECEIVING WATER (RW) RISK FACTOR WORKSHEET

Is the project area or project section area located within a Sediment Sensitive Watershed*? Yes

Is the project area or section located within the flood plain or flood prone area (riparian zone) of a Sensitive Receiving Water Body*? No
[Statewide Map of High Receiving Water Risk Watersheds](#)

C. Combined Risk Level Matrix

		Sediment Risk		
		Low	Medium	High
Receiving Water Risk	Low	Type1	Type2	Type3
	Medium	Type1	Type2	Type3
	High	Type2	Type3	Type3

Segment Sediment Risk:

Segment Receiving Water Risk:

Segment Combined Risk:

Appendix IV LUP Risk Type Determination

1 LUP Type Determination

The boundaries of this area are as described below:

Area	From	To	Risk Type
	GPS/Description	GPS/Description	
Segment 1A: Sycamore Substation to MCAS Miramar Boundary	32.91733 °N, -117.03073°W	32.91983°N, -117.03223°W	1
Segment 2A: MCAS Miramar Boundary to P5; Including staging yards Stowe and Stonebridge	32.91983°N, -117.03223°W	32.92250°N, -117.04244°W	1
Segment 3B: P5 to I-15 Bridge	32.92250°N, -117.04244°W	32.89347°N, -117.11358°W	1
Segment 4B: 1-15 Bridge Crossing	32.89347°N, -117.11358°W	32.89361°N, -117.11801°W	1
Segment 5B: 1-15 to Carroll Canyon; Including staging yards Site 1A, Site 1B, Site 2, Site 3, Shire Property (Sites 4A-4C), Driving Range (Site 5), Evergreen Nursery and Carmel Valley	32.89361°N, -117.11801°W	32.88984°N, -117.20303°W	1
Segment 6C: Carroll Canyon to Coastal Zone Boundary South End	32.88984°N, -117.20303°W	32.89926°N, -117.20886°W	2
Segment 7C: Coastal Zone	32.89926°N, -117.20886°W	32.91185°N, -117.21662°W	3
Segment 8C: Costal Zone Boundary North End to Peñasquitos Substation	32.91185°N, -117.21662°W	32.91825°N, -117.21923°W	1

The Risk Type determination is based on the information below and Attachment A.1 and Appendix 1 of the CGP.

2 Construction in Developed Areas

- Segments 3B, 4B and 5B of this project meet the criteria in the flowchart on Page 1 of Attachment A.1 to be categorized as a Risk Type 1 project area. The following describes the criteria that have been satisfied:

At least 70% of construction activity for segments 3B, 4B and 5B will occur on paved surfaces and areas disturbed will be returned to pre-construction or equivalent conditions at the end of the day. Segments 1A, 2A, and 8C do not meet the criteria on Page 1 and are a Risk Type 1 as evaluated below. Segments 6C does not meet the criteria on page 1 and is a Risk Type 2 as evaluated below. Segment 7C does not meet the criteria on Page 1 and is a Risk Type 3 as evaluated below.

3 Receiving Water

This section identifies the receiving waters into which the discharges from these areas discharge and the conditions and requirements for this project.

- **Receiving Water Name(s):** Segments 1A and 2A: Unnamed tributary to Beeler Canyon to Los Peñasquitos Creek to Los Peñasquitos Lagoon. Segments 3B, 4B and 5B: Unnamed tributary to Carroll Canyon to Soledad Canyon to Los Peñasquitos Creek to Los Peñasquitos Lagoon. Segment 6C: Carroll Canyon to Soledad Canyon to Los Peñasquitos Creek to Los Peñasquitos Lagoon. Segment 7C: Los Peñasquitos Creek to Los Peñasquitos Lagoon; Unnamed tributary to Soledad Canyon to Los Peñasquitos Creek to Los Peñasquitos Lagoon. Segment 8C: Unnamed tributary to Los Peñasquitos Lagoon.

Hydrologic Number(s)/Name(s): Segments 1A, 2A, and 3B: Los Peñasquitos Hydrologic Unit/Poway Hydrologic Area (906.20); Segments 4B, 5B, 6C, 7C and 8C: Los Peñasquitos Hydrologic Unit/Miramar Reservoir Hydrologic Area (906.10).

- **Surface Water Quality Objectives** applicable to this project’s receiving waters are contained in Appendix IV.

Table 3-2. Water Quality Objectives (continued)
Concentrations not to be exceeded more than 10% of the time during any one year period.

Inland Surface Waters		Hydrologic Unit Basin Number	Constituent (mg/L or as noted)													
			TDS	Cl	SO ₄	%Na	N&P	Fe	Mn	MBAS	B	ODOR	Turb NTU	Color Units	F	
PENASQUITOS HYDROLOGIC UNIT		906.00														
Miramar Reservoir	HA	6.10	500	250	250	60	a	0.3	0.05	0.5	0.75	none	20	20	1.0	
Poway	HA	6.20	500	250	250	60	a	0.3	0.05	0.5	0.75	none	20	20	1.0	
Scripps	HA	6.30	-	-	-	-	a	-	-	-	-	none	20	20	-	
Miramar	HA	6.40	500	250	250	60	a	0.3	0.05	0.5	0.75	none	20	20	1.0	
Tecolote	HA	6.50	-	-	-	-	a	-	-	-	-	none	20	20	-	
SAN DIEGO HYDROLOGIC UNIT		907.00														
Lower San Diego	HA	7.10	1,000	400	500	60	a	0.3	0.05	0.5	1.0	none	20	20	-	
Mission San Diego	HSA	7.11	1,500	400	500	60	a	1.0	1.00	0.5	1.0	none	20	20	-	
Santee	HSA c,	7.12	1,000	400	500	60	a	1.0	1.00	0.5	1.0	none	20	20	-	
Santee	HSA d	7.12	1,500	400	500	60	a	1.0	1.00	0.5	1.0	none	20	20	-	
San Vicente	HA	7.20	300	50	65	60	a	0.3	0.05	0.5	1.0	none	20	20	1.0	
El Capitan	HA	7.30	300	50	65	60	a	0.3	0.05	0.5	1.0	none	20	20	1.0	
Boulder Creek	HA	7.40	300	50	65	60	a	0.3	0.05	0.5	1.0	none	20	20	1.0	
PUEBLO SAN DIEGO HYDROLOGIC UNIT		908.00														
Point Loma	HA	8.10	-	-	-	-	-	-	-	-	-	none	20	20	-	
San Diego Mesa	HA	8.20	-	-	-	-	-	-	-	-	-	none	20	20	-	
National City	HA	8.30	-	-	-	-	-	-	-	-	-	none	20	20	-	

HA - Hydrologic Area
HSA - Hydrologic Sub-Area (Lower case letters indicate endnotes following the table)

- **Specific information** for the **receiving waterbodies** listed above (Check all that apply):
 - Listed on SWRCB’s 303(d) list for sedimentation, siltation or turbidity.

A Total Maximum Daily Load (TMDL) has been adopted that addresses this impairment.

Name of Waterbody / Impairment:

A TMDL has not yet been adopted for this impairment.

Listed on SWRCB's 303(d) list for pollutants other than sedimentation, siltation or turbidity.

A TMDL has been adopted that addresses this impairment.

Name of Waterbody / Impairment:

Los Peñasquitos Creek – Toxicity, Enterococcus, Fecal Coliform, Selenium,
Total Dissolved Solids and Total Nitrogen as N.

A TMDL has not yet been adopted for this impairment.

The 303(d) and/or TMDL requirements identified above are incorporated into the SWPPP site map/plans/drawings and other appropriate sections of the SWPPP.

o **Specific information** for the **watersheds** down-gradient from the receiving water body (Check all that apply):

No surface waters are listed on the SWRCB's 303(d) list for sedimentation, siltation or turbidity.

A surface water body is listed on SWRCB's 303(d) list for sedimentation, siltation or turbidity.

Name of Waterbody / Impairment:

Los Peñasquitos Lagoon – Sedimentation/Siltation

A TMDL has been adopted that addresses this impairment.

Name of Waterbody / Impairment:

- A TMDL has not yet been adopted for this impairment.
- No surface waters are listed on the SWRCB's 303(d) list for pollutants other than sedimentation, siltation or turbidity.
- A surface water body is listed on SWRCB's 303(d) list for pollutants other than sedimentation, siltation or turbidity.

Name of Waterbody / Impairment:

- A TMDL has been adopted that addresses this impairment.

Name of Waterbody / Impairment:

Soledad Canyon – Sediment Toxicity and Selenium

- A TMDL has not yet been adopted for this impairment.

- The 303(d) and/or TMDL requirements identified above are incorporated into the SWPPP site map/plans/drawings and other appropriate sections of the SWPPP.

The following criteria applies to this project area:

- The project area is located within a Sediment Sensitive Watershed based on:
 - List of Sediment Sensitive Watersheds (see Appendix 4 of the CGP); ***or***
 - SWRCB's GIS map of Sediment Sensitive Watersheds
- The project area is located within the flood plain or flood prone area (riparian zone) of a Sensitive Receiving Water Body.

Based on the flowchart on Page 2 of Attachment A.1 of the CGP and the above information, the **Receiving Water Risk** for each Segment is identified below.

Segments 1A, 2A, 3B, 4B and 5B: **Low**

Segments 6C, and 8C: **Medium**

Segment 7C: **High**

4 Sediment Risk:

Use the Sediment Risk Factor Worksheet in Appendix 1 of the CGP to calculate the area's Sediment Risk Factor, with the inputs identified below.

"R" Factor Determination

The construction schedule for each segment is provided below.

Segment 1A:

Estimated Date Construction will begin: *February 15, 2017*

Estimated Completion Date: *March 15, 2017*

Segment 2A:

Estimated Date Construction will begin: *January 15, 2017*

Estimated Completion Date: *March 15, 2017*

Segment 3B and 5B:

Estimated Date Construction will begin: *January 15, 2017*

Estimated Completion Date: *June 20, 2018*

Segment 4B:

Estimated Date Construction will begin: *August 17, 2017*

Estimated Completion Date: *June 20, 2018*

Segment 6C and 8C:

Estimated Date Construction will begin: *January 15, 2017*

Estimated Completion Date: *May 30, 2017*

Segment 7C:

Estimated Date Construction will begin: *February 15, 2017*

Estimated Completion Date: *May 30, 2017*

The location of each segment used to determine the "R" factor is provided below. :

Segment 1A: 32.9185°N, -117.0314°W

Segment 2A: 32.9212°N, -117.0373°W

Segment 3B: 32.9072°N, -117.0773°W

Segment 4B: 32.8932°N, -117.1156°W
Segment 5B: 32.8917°N, -117.1605°W
Segment 6C: 32.8946°N, -117.2059°W
Segment 7C: 32.9056°N, -117.2127°W
Segment 8C: 32.9151°N, -117.2179°W

Based upon the above inputs, the “R” factor for each segment is provided below.

Segment 1A: 6.49

Segment 2A: 14.53

Segment 3B: 56.81

Segment 4B: 34.83

Segment 5B: 53.75

Segment 6C: 16.73

Segment 7C: 9.74

Segment 8C: 16.73

“K” and “LS” Factor Determination (Segment 2)

“K” and “LS” Factors were populated on SMARTs.

The “K” Factor is:

Segment 1A: 0.2

Segment 2A: 0.2

Segment 3B: 0.2

Segment 4B: 0.24

Segment 5B: 0.24

Segment 6C: 0.43

Segment 7C: 0.43

Segment 8C: 0.2

The “LS” Factor is:

Segment 1A: 5.188

Segment 2A: 5.188

Segment 3B: 3.671

Segment 4B: 2.235

Segment 5B: 2.235

Segment 6C: 4.349

Segment 7C: 4.349

Segment 8C: 3.671

The **Watershed Erosion Estimate = K*LS*R:**

- Segment 1A: 6.73 tons/acre**
- Segment 2A: 15.08 tons/acre**
- Segment 3B: 41.71 tons/acre**
- Segment 4B: 18.68 tons/ acre**
- Segment 5B: 28.83 tons/acre**
- Segment 6C: 31.29 tons/acre**
- Segment 7C: 18.22 tons/acre**
- Segment 8C: 12.28 tons/acre**

The associated **Site Sediment Risk Factor:**

- Segment 1A: Low**
- Segment 2A: Medium**
- Segment 3B: Medium**
- Segment 4B: Medium**
- Segment 5B: Medium**
- Segment 6C: Medium**
- Segment 7C: Medium**
- Segment 8C: Low**

- “K” factor was determined using site specific information as described below:

The **“K” Factor** is **N/A.**

- “The “LS” factor was determined using site specific information as described below:

The **“LS” Factor** is **N/A.**
The **Site Sediment Risk Factor = N/A**

5 Area Type Determination

Based upon the Risk Matrix on Page 2 of Attachment A.1 in the CGP and the above receiving water and sediment risk factors, Segments 1A, 2A, 3B, 4B, 5B and 8C are **Risk Type 1**, Segment 6C is **Risk Type 2** and Segment 7C is **Risk Type 3**.

APPENDIX V
CONSTRUCTION MATERIALS

Appendix V Potential Materials Used or Stored

Activity	Typical Materials	
Asphalt Work	Asphalt (conventional and rubberized) Cold mix Asphalt emulsion Asphalt releases – Monocyclic Terpet	Liquid asphalt Aluminate Aluminum sulfate Chip seal, seal coat, tack coat, slurry seal or fog seal
Concrete Work	Concrete curing compound – resin based “Monkey blood” (a retardant compound used for concrete curing) Arbitol Arabitol (1,2,3,4,5-pentane pentol) pH from concrete sawing or freshly placed or washed off Portland cement products	Diesel fuel (sprayed on wooden forms as a non-sticking compound between concrete and wood) Cement Concrete mix Concrete slurry
Cleaning	Various citrus based cleaners Solvents Thinners De-greasers Acids	Bases Detergents Trisodium phosphate Sodium Hypochlorite
Vehicle and Equipment	Oil, Grease, Fuel Grease Coolant/antifreeze Diesel	Gasoline Lubricants Hydraulic and/or brake fluid Adhesives (glues, caulk, sealants)
Pipe Work	Pipe joint compound ABS and PVC primers Chlorine – water line flushing disinfection	
Painting	Paints Thinners Mineral spirits	Latex paint (propylene glycol) Epoxy Silicone
Electrical Work (Materials and Equipment)	Wooden electrical utility poles Electrical transformers and other electrical equipment Pole anchors Guy wires	Conductor cable Stub supports Electrical distribution wire
Gas Work (Material and Equipment)	Poly pipe Steel pipe Pipe wrap primer Pipe wrap Pipe pillows Pipe skids or blocks	Welding rods Miscellaneous steel fittings Metal and plastic pipelines Valves, pressure regulators Cable and conduit

Appendix V Potential Materials Used or Stored

Activity	Typical Materials	
Landscaping	Herbicides Pesticides Fertilizers	Mulch Compost
Brick Work	Etching compounds Acid wash of brick work	
Soil Stabilization	Wood fiber mulch Compost Wood and bark chips Straw mulch Emulsified asphalt Lime	Plant gums Bonded fiber matrix Coconut fiber Paper mulch Grass Various proprietary products
Dust Palliatives – petroleum based (Note these are not recommended because of groundwater concerns and plant growth inhibition)	Bunker oil Asphalt primer Emulsified asphalt	
Dust Palliatives – salts (note these are not recommended because they inhibit plant growth)	Magnesium chloride Calcium chloride Natural brines	
Dust Palliatives – organic	Calcium lignosulfate Sodium lignosulfate Ammonium lignosulfate	
Woodwork	Lumber treatment/ preservative Water sealants Stains Sawdust	
Structural finishing	Plaster Fire retardants Epoxies	Paints (see painting) Tar Urethane

INVENTORY OF POTENTIAL POLLUTANT SOURCES PLANNED TO BE USED OR STORE AT THE PROJECT SITE (Completed Form Stored in Appendix V)

Project Name Sycamore – Peñasquitos 230 kV Transmission Line Project

WDID Number _____

Date: _____

- Conduct an inventory of the products used and/or expected to be used and the end products that are produced and/or expected to be produced at the site.
- As a reference a list of possible products that are typically found at construction sites are listed in Appendix V.

Typical Materials Handled, Produced, Stored, Recycled, or Disposed of at the Site	Quantity (e.g., gal, lbs, oz)	Physical Characteristics (e.g., liquid, powder, solid)	Location and Containment	Distance to Storm Drain Inlet/Receiving Waters

**Inventory of Potential Pollutant Sources Planned to be Used or Store at the Project Site
(Completed Form Stored in Appendix V)**

Based on the table above, describe the degree to which pollutants associated with those materials may be exposed to and mobilized by contact with storm water (ie proximity to storm drain inlets or receiving waters).

Materials will be stored in designated storage locations in conditions to prevent exposure, and materials at active construction areas will be used or stored in ways that prevent exposure to storm water, e.g. stored in trucks and not exposed during storm water events. Exposure of disturbed soil to storm water will be minimized.

Describe BMPs implemented to address these pollutant sources below:

For most pollutant sources, proper storage and immediate response to any spills or leakage should be sufficient. If needed, additional BMPs will be implemented.

Disturbed soil will be managed to minimize exposure and retain sediment onsite, including use of fiber rolls and silt fence to control sediment.

Consider the direct and indirect pathways that pollutants may be exposed to storm water or authorized non-storm water discharges. This shall include an assessment of past spills or leaks, non-storm water discharges, and discharges from adjoining areas

Based on the inventory and evaluation above, describe the anticipated pollutants for the project below and include these analytes in the Monitoring & Reporting Program (M&RP) in Appendix X of the SWPPP.

APPENDIX VI
CONSTRUCTION BMPS

CONSTRUCTION BMPs

[SDG&E BMP Manual]



What	Scheduling consists of the planning of soil disturbance activities to avoid periods of rain whenever practical.
When	Scheduling of soil disturbance activities must be considered year-round.
Where	All construction and “construction like” operations and maintenance sites where soil disturbance activities take place.
How	<p>Use the following measures as applicable:</p> <ul style="list-style-type: none">• Consider scheduling major soil disturbing activities or activities near environmentally sensitive areas (e.g., adjacent to water bodies) during prolonged periods when no rain is forecast.• Monitor the weather forecast for seasonable and unseasonable rain events. Obtain weather information from the National Weather Service at<ul style="list-style-type: none">○ www.srh.noaa.gov/• Print and maintain copies of forecasts to document decisions related to inspections and BMP implementation for projects subject to the CGP.• Appropriate sediment controls are required year round. Always be prepared to deploy additional erosion and sediment control and soil stabilization BMPs as needed. Off site sediment discharges can occur because of unseasonable rain, vehicle tracking, unanticipated wind, and non-storm water discharges.• Sequence work to minimize soil-disturbing activities during forecasted rain events.• Limit disturbed soil area to the amount of acreage that can be protected prior to a forecasted rain event.• Stabilize disturbed soil areas as soon as practical, and always prior to a forecasted rain event (See Section 4, Soil Erosion BMPs for soil stabilization methods).• Protect environmentally sensitive areas, such as drainage channels, streams, and natural watercourses.• When rain is forecast, adjust the construction schedule to implement soil stabilization and sediment controls on all disturbed areas prior to the onset of rain.
Maintenance and Inspection	<ul style="list-style-type: none">• Review applicable scheduling and sequencing of construction activities throughout the project or activity to minimize the total area of exposed soil and the exposed soil exposure time.• Inspect erosion and sediment controls prior to and after each storm event, and routinely throughout the construction and/or clean-up activity. If inspections warrant construction BMP changes, amend the schedule accordingly.

Pictures



Corresponding CASQA Fact Sheet

Fact Sheet EC-1

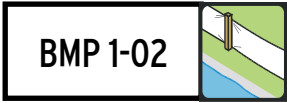

What	Silt fences are temporary linear sediment barriers made of permeable fabric that lets water through but prevents the majority of sediment from passing through. Silt fences also act by intercepting and slowing the flow of sediment-laden runoff and allowing sediment to settle from the runoff before water leaves the construction site.
When	<ul style="list-style-type: none"> • Silt fences are designed to intercept sheet flows to moderately concentrated flows. • Generally, silt fences shall be used in conjunction with soil stabilization source controls up slope (see Section 4) to provide effective control, particularly for steep slopes, and slopes adjacent to water bodies or Environmentally Sensitive Areas (ESAs). • Consider BMP 1-03 “Fiber Rolls” for minor slopes or perimeter sediment control on flat or slightly sloped areas.
Where	<p>Silt fences are placed:</p> <ul style="list-style-type: none"> • Below the toe of exposed and erodible slopes. • Down-slope of exposed soil areas. • Around temporary stockpiles. • Along streams and channels. • Along the perimeter of a project. • Consider BMP 1-03 “Fiber Rolls” for small stockpiles and perimeters of areas with shallow slopes.
How	<ul style="list-style-type: none"> • Construct silt fences with a setback of at least 3 feet from the toe of a slope in areas suitable for temporary ponding or deposition of sediment. Where a 3-foot setback is not practical, construct as far from the toe of the slope as practical. • Construct the length of each reach (length of fence) so that the change in base elevation along the reach does not exceed one-third of the barrier height; each reach should not exceed 500 feet. The last 6 feet of the reach should be turned up slope. • The maximum length of slope draining to the silt fence should be 200 feet or less. • Excavate a trench approximately 6 inches wide and 6 inches deep to place the bottom of the silt fence into, ensuring that is not wider or deeper than necessary. • Key-in, or bury the bottom of silt fence fabric in the trench and tamp into place. If it is not feasible to trench along the slope contour, use sand bags or backfilling to key in the bottom of the fabric. • Install fence posts at least 12 inches below grade on the down slope side of trench. • Silt fences should not be used to divert water. Silt fences should not be considered for installation below slopes steeper than 1:1 (vertical: horizontal) or that contain a high number of rocks or loose dirt clods unless the rocks are removed and erosion and soil stabilization controls (Section 4) are used up slope. • Repair or replace split, torn, slumping, undercut or weathered fabric. Note that fabric may need to be replaced when installation is required for more than 5 to 8 months due to limited durability.



Maintenance and Inspection

Maintenance and Inspection (cont.)

- Inspect silt fences prior to and after each storm event, daily during extended rain events during the construction and/or clean-up activity (e.g., weekly, or in compliance with the frequency specified in the project specific SWPPP, if applicable). Initiate repairs related to a storm event within 72 hours of identifying the problem or as soon as possible but prior to the next predicted storm event, per the CGP.
- Remove accumulated sediment when it reaches one third of the barrier height. Removed sediment shall be incorporated in the project at appropriate locations or disposed of in accordance with federal, state and local requirements.
- Silt fences that are damaged and become unsuitable for the intended purpose shall be removed and disposed of and replaced with new silt fence barriers or other applicable control.
- Remove silt fence when no longer needed and after up-gradient areas are permanently stabilized. Fill and compact post-holes and the anchor trench, remove sediment accumulation, and work the surface of the fence alignment to blend with adjacent ground.

Pictures



Silt fence installed with at least a 3 foot setback from the toe of an erodible slope. Note that use is combined with fiber rolls and serves as perimeter control.

Corresponding CASQA Fact Sheet

Fact Sheet SE-1

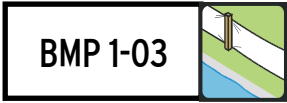

What A fiber roll (straw waddle) consists of straw, flax or other similar materials that are rolled and bound into a roll. The fiber roll lets water through but prevents the majority of sediment from passing through. Fiber rolls also act by intercepting and slowing the flow of sediment-laden runoff and allowing sediment to settle from the runoff before water leaves the construction site. In sensitive vegetation areas, only certified weed-free rice straw is to be used.

When Fiber rolls are used for sheet flow or where flows are slightly to moderately concentrated.

Where Fiber rolls are generally placed on the face of slopes at regular slope intervals to intercept runoff, reduce flow velocity, release the runoff as sheet flow and provide sediment removal.

- May be used along the top, face and at grade breaks of exposed and erodible slopes to shorten slope length and spread runoff as sheet flow.
- Fiber rolls are appropriate for perimeter site control or along streams, channels, storm drain inlets, or around stockpiles to intercept sediment-laden storm water and non-storm water runoff.

How Installation

- Locate fiber rolls on level contours spaced in accordance with the CGP requirements for LUP Type 2 & 3 and Risk Level 2 & 3 sites as follows:

Slope Grade	Spacing (sheet flow length not to exceed)
0-25%	20 feet
25-50%	15 feet
Over 50%	10 feet

- In non-paved areas, stake fiber rolls into a trench that is the width of the roll and one-third the depth of the roll (2- to 4-inch deep trench).
- Drive stakes into fiber rolls at a minimum of 4-foot intervals.
- If more than one fiber roll is placed in a row, fiber rolls should be overlapped and not abutted together.

Removal

- When used in a permanent application, fiber rolls can be left in place.
 - Permanent fiber rolls are typically encased with a biodegradable material.
 - Note that removal can result in greater soil disturbance.
- When used for a temporary application as storm drain inlet protection or stockpile control for example, the fiber rolls should be removed at the completion of the construction cleanup activity in that area.
 - Temporary fiber rolls are typically encased with plastic netting that does not biodegrade.
 - Remove fiber rolls only when up gradient areas are stabilized and/or pollutant sources are no longer a hazard.

SEDIMENT CONTROLS

Fiber Rolls (Waddles)

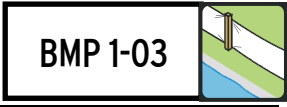

How (cont.)

- Remove fiber rolls before vegetation becomes too mature to avoid unnecessary soil and vegetation disturbance.
 - If fiber rolls are removed, collect and dispose of fiber roll and sediment accumulation as appropriate in accordance with federal, state and local requirements. Trapped sediment may be incorporated into the construction site. Fill and compact holes, trenches, depressions, or any other ground disturbance to blend with adjacent ground.
- Note that the cost of disposal of wet fiber rolls may be more expensive than dry fiber rolls.

Maintenance and Inspection

- Repair or replace spilt, torn, unraveling, or slumping fiber rolls.
- Inspect fiber rolls if rain is forecasted and perform maintenance as needed.
- Inspect fiber rolls prior to and after each rain event, and daily during extended rain events throughout the construction and/or clean-up activity (e.g., weekly, or in compliance with the frequency specified in the project specific SWPPP, if applicable). Initiate repairs related to a storm event within 72 hours of identifying the problem or as soon as possible but prior to the next predicted storm event, per the CGP.
- Do not use fiber rolls containing polyacrylamide or other flocculants. Use is considered "active treatment" and is subject to ATS requirements of the CGP (see BMP Detail 1-12).

Pictures



Fiber rolls as perimeter control.

**Pictures
(cont.)**



Fiber roll installation on the face of a slope.

**Corresponding
CASQA
Fact Sheet**

Fact Sheet SE-5



What	A gravel bag berm consists of at least a single row of gravel bags that are installed end-to-end to form a barrier across a slope to intercept runoff.
When	<p>Use gravel bag berms:</p> <ul style="list-style-type: none"> • When needed to reduce storm water flow velocity, release the runoff as sheet flow, and provide some sediment removal. • Gravel bag berms can also be used when flows are moderately concentrated and when it is desirable to filter sediment in runoff. Gravel bag berms are generally more permeable than sand bags.
Where	<ul style="list-style-type: none"> • Ditches, swales, and storm drain inlets • Gravel bag berms are also appropriate for perimeter site control or along streams, channels, storm drain inlets, or around stockpiles to intercept sediment laden storm water and non-storm water runoff. • Along the face and at grade breaks of exposed and erodible slopes to shorten slope length and spread runoff as sheet flow. • Gravel bags may be implemented with other BMPs to maximize sediment containment. • Sand bag barriers should be used in cases where it is desirable to block and pond flows (BMP 1-05 "Sand Bag Barrier").
How	<ul style="list-style-type: none"> • When used as a linear control for sediment removal: <ul style="list-style-type: none"> ○ Install along a level contour. ○ Turn ends of gravel bag row up slope to prevent flow around the ends. ○ Generally, gravel bag barriers are used in conjunction with temporary soil stabilization controls up slope to provide effective control. • When used for concentrated flows: <ul style="list-style-type: none"> ○ Stack gravel bags to required height. When the height requires 3 rows or more, use a pyramid approach. ○ Upper rows of gravel bags shall overlap joints in lower rows. • Construct gravel bag barriers with a setback of at least 3 feet from the toe of a slope. Where a 3-foot setback is not practical, construct as far from the toe of the slope as practical.
Maintenance and Inspection	<ul style="list-style-type: none"> • Perform routine inspections of gravel bag berms prior to and after each storm event, and daily during extended rain events throughout the construction and/or clean-up activity (e.g., weekly, or in compliance with the frequency specified in the project specific SWPPP, if applicable). Initiate repairs related to a storm event within 72 hours of identifying the problem or as soon as possible but prior to the next predicted storm event, per the CGP. • Reshape or replace gravel bags as needed. • Repair washouts or other damage as needed. Note that bags may need to be replaced when installation is required for more than 6 months due to limited durability. • Inspect gravel bag berms for sediment accumulations and remove sediment when accumulation reaches one-third of the berm height. Removed sediment shall be incorporated in the project at appropriate locations or disposed of in accordance with federal, state and local requirements.

SEDIMENT CONTROLS

Gravel Bag Berm

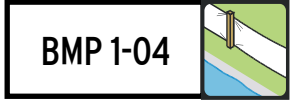

Maintenance and Inspection (cont.) Pictures

- Remove gravel bag berms when no longer needed and when feasible, recycle gravel fill. Remove sediment accumulation, and clean, re-shape, and stabilize the area. Removed sediment shall be incorporated in the project at appropriate locations or disposed of in accordance with federal, state and local requirements.



Gravel bags and fiber rolls used as perimeter sediment controls.



Gravel bags used as perimeter control.

Corresponding CASQA Fact Sheet

Fact Sheet SE-6



What	A BMP or a combination of BMPs used at storm drains or other drainage inlets to protect against the discharge of sediment-laden storm water and non-storm water runoff from construction or operational and maintenance activities. The BMP slows or ponds the storm water flow, giving the sediment time to settle out before discharge to the storm drain.
When	This BMP is required on all construction projects and operation and maintenance sites when sediment laden surface runoff may enter a storm drain inlet and/or drainage to watercourses. Do not construct when runoff will result in ponding into road traffic or onto erodible surfaces or slopes, or overflow onto the sidewalk.
Where	At downstream storm drain and/or drainage inlets that have the potential to be impacted by construction or "construction like" operation and maintenance activity, site storm water run-off, or non-storm water discharges.
How	<ul style="list-style-type: none">• Identify all downstream storm drain inlets or drainages that have the potential to receive runoff or non-storm water discharges from construction activities.• Where a storm drain or drainage inlet is on or at the bottom of a slope, a series of small check dams (i.e., gravel bag berms) constructed at intervals along the slope may be required to slow the runoff. See BMP 1-11.• Select appropriate protection and construct inlet protection based on the configuration of inlets at the site.• Some municipalities require removal of BMPs from storm drains within 72 hours of a rain event (e.g., City of San Diego requires removal of inlet protection in the case that 0.25 inch or greater of rain is predicted). Consult with your project Field Environmental Representative for local requirements.• Remove inlet protection devices at the end of the construction period, or when the inlet can no longer be impacted by the project or activity.
Maintenance and Inspection	<ul style="list-style-type: none">• Perform routine inspections of BMPs prior to and after storm event, and daily during extended rain events throughout the construction and/or clean-up activity (e.g., weekly, or in compliance with the frequency specified in the project specific SWPPP, if applicable). Initiate repairs related to a storm event within 72 hours of identifying the problem or as soon as possible but prior to the next predicted storm event, per the CGP.• During inspections:<ul style="list-style-type: none">○ Inspect bags, silt fence, or filter fabric for holes, gashes, and snags.○ Check gravel bags for proper arrangement and displacement.○ Remove the sediment behind the barrier when it reaches one-third of the barrier height. Removed sediment should be incorporated in the project or disposed of in accordance with federal, state and local requirements.

Pictures

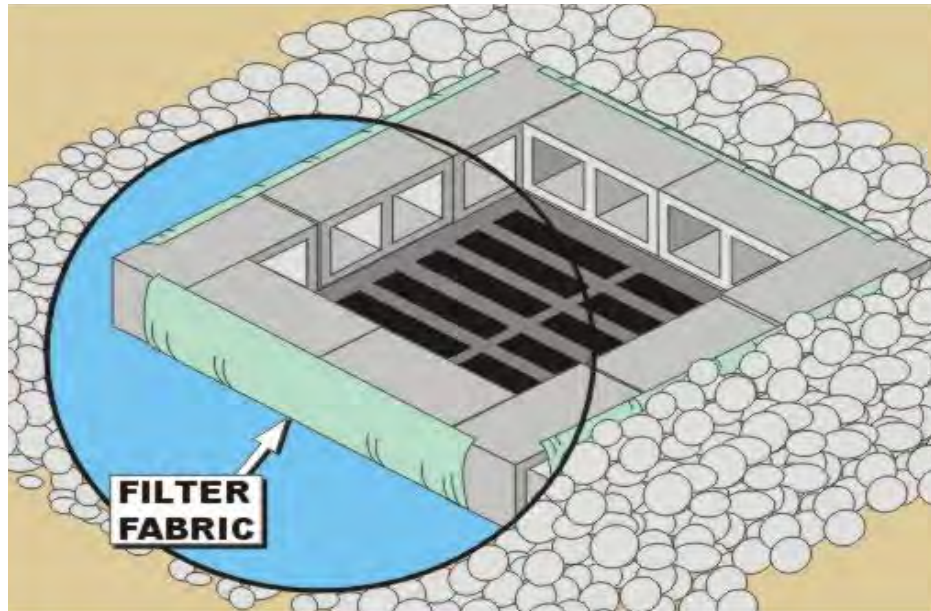

Block and gravel-type inlet protection.



Inlet protection that blocks flow, preventing non-storm water discharges from entering drain.

SEDIMENT CONTROLS

Storm Drain/Drainage Inlet Protection

BMP 1-06 

Pictures (cont.)



Gravel bag inlet protection.



Inlet protection using fiber rolls and filter fabric.

Corresponding CASQA Fact Sheet

Fact Sheet SE-10



- What** Tracking controls consist of constructed/manufactured steel plates (rumble plates) or gravel. Tracking controls reduce offsite tracking of sediment and other pollutants by providing a stabilized entrance at defined soil disturbance activity site entrances and exits with materials that aid in removing sediment from vehicles, especially their tires or tracks. Controls can also consist of providing methods to clean-up sediment or other materials to prevent them from entering a storm drain, such as sweeping or vacuuming. Tracking controls can also include implementing tire washing.
- When**
- Stabilized entrances/exits should be implemented on each soil disturbance site having a defined entrance/exit consisting of soil which terminates into a paved roadway or substantial paved surface. Stabilized entrances/exits are in addition to other applicable BMPs.
 - Daily sweeping or vacuuming should be implemented when sediment is tracked from the site onto public or private paved roads, typically at points of site exit.
 - Install and implement tire washing when the above methods are not adequately controlling track-out.
- Where** Use stabilized entrances and/or sweeping (and tire washing, if needed) at construction and “construction like” operations and maintenance activity sites:
- where dirt or mud is tracked onto public roads;
 - adjacent to water bodies;
 - where poor soils are encountered, such as soils containing clay; and
 - where dust is a problem during dry weather conditions.
- How**
- Stabilized Entrances
- Limit the points of entrance/exit to the construction or operations and maintenance site by designating combination or single purpose entrances and exits. Require all employees, subcontractors and others to use them. Limit speed of vehicles to control dust.
 - Where feasible, grade each construction entrance/exit to prevent runoff from leaving the construction site.
 - Route runoff from stabilized entrances/exits through a sediment-trapping device before discharge (see BMP 1-10).
 - Design stabilized entrance/exit to support heaviest vehicles and equipment.
 - Select construction access stabilization (aggregate, asphaltic concrete, concrete) based on longevity, required performance, and site conditions.
 - Use of constructed or constructed/manufactured steel plates with ribs for entrance/exit access is allowed.
 - If aggregate is selected, place crushed aggregate over geotextile fabric to at least 12 inches deep, or place aggregate to a depth recommended by a geotechnical engineer. A crushed aggregate greater than 3 inches but smaller than 6 inches shall be used.
- Street Sweeping and Vacuuming
- Inspect potential sediment tracking locations routinely.
 - Visible sediment tracking should be swept or vacuumed as needed. Manual sweeping is appropriate for small jobs.

How



- (cont.)**
- For larger projects, it is preferred to use mechanical sweeping methods that collect removed sediment and material.
 - If not mixed with debris or trash, incorporate the removed sediment back into the project or dispose of in accordance with federal, state and local requirements.
- Tire Washing
- Design wash rack to support the heaviest traffic loads.
 - Provide a turnout or doublewide exit to avoid traffic from entering through the tire washing area.
 - Design a drainage ditch to route all rinse or wash waters from the tire washing area to a sediment trapping device (see BMP 1-10) to prevent any wash runoff from leaving the site.
 - Hoses should be equipped with automatic shutoff nozzles.
- Maintenance and Inspection**
- Stabilized Entrances
- Inspect routinely for damage and assess effectiveness. Remove sediment and repair if the stabilized entrance/exit is clogged with sediment.
 - Perform routine inspections of BMPs, prior to and after storm events, and daily during extended rain events throughout the construction and/or clean-up activity (e.g., weekly, or in compliance with the frequency specified in the CGP, if applicable). Initiate repairs related to a storm event within 72 hours of identifying the problem or as soon as possible but prior to the next predicted storm event, per the CGP.
 - Where tracking has occurred on roadways, sweeping should be conducted the same day. Water should not be used to wash sediment off the streets, unless necessary. If water is used, it must be captured, preventing sediment-laden water from running off the street or site.
 - Keep all temporary roadway ditches clear.
- Street Sweeping and Vacuuming
- Inspect silt fences prior to and after each storm event, daily during extended rain events during the construction and/or clean-up activity (e.g., weekly, or in compliance with the frequency specified in the project specific SWPPP, if applicable). Initiate repairs related to a storm event within 72 hours of identifying the problem or as soon as possible but prior to the next predicted storm event, per the CGP.
 - Inspect all site paved access roads daily and remove any sediment or other materials on the roads by vacuuming or sweeping daily, as needed, and prior to any rain event in accordance with the CGP Risk Levels 2 & 3 requirements.
 - Be careful not to sweep up any unknown substance or any object that may be potentially hazardous.
 - After sweeping is finished, properly dispose of sweeper wastes.
- Tire Washing
- Inspect BMPs prior to and after each storm event, daily during extended rain events during the construction and/or clean-up activity (e.g., weekly, or in compliance with the frequency specified in the project specific SWPPP, if applicable). Initiate repairs related to a storm event within 72 hours of identifying the problem or as soon as possible but prior to the next predicted storm event, per the CGP.
 - Inspect rack and/or sediment trap system routinely for damage and assess effectiveness. Remove accumulated sediment to maintain system

performance.

Pictures



Manufactured metal plates knock dirt off vehicle tires before exiting a site.



Drive through wheel wash before exiting a site.

**Corresponding
CASQA
Fact Sheet**

Fact Sheets TC-1, TC-2, TC-3, and SE-7



- What** Stockpile management consists of placing temporary BMPs, such as secured covers, over the piles, and/or placing berms, silt fences, fiber rolls, sand/gravel bags or straw bale barriers around the perimeter of stockpiles. Soil stabilizers/binders may also be used to augment stockpile management (BMP 4-05).
- When** Use this BMP when construction projects or operation and maintenance activities require stockpiled soil, waste materials, and/or paving materials. Protection of stockpiles must be implemented whenever there is a potential for transport of materials by a water source or by wind.
- Construction and waste material stockpiles require protection from rain and wind at all times unless actively being used (protect during non-activity). Projects with SWPPPs require protection at the end of each day.
- Where** Stockpiles at construction and “construction like” operation and maintenance activity sites, protecting against both run-on and run-off.
- How** One or more of the following options may be used to manage stockpiles and prevent stockpile erosion and sediment discharges for storm water and non-storm water runoff/run-on.
- Stockpile may be returned to the excavation if precipitation is forecast.
 - Sufficient BMP materials for temporary stockpile protection should be available onsite. Select cover materials or methods based on anticipated duration.
 - Protect stockpiles from storm water run-on and sediment runoff from the stockpiles using a temporary perimeter sediment barrier such as berms, silt fences, fiber rolls, sand/gravel bags, or straw bale barriers, as appropriate.
 - Cover stockpiles to prevent erosion. Note that the CGP requires that inactive stockpiles be covered. Where feasible, cover/protect stockpiles using a soil binder, according to BMP 4-05. Alternately, secure stockpiles with covers such as Visqueen weighted down with gravel bags, or sand bags. Plastic should be properly re-used or disposed of properly. Note the CGP discourages the use of plastic materials for cover when more sustainable alternatives can be used.
 - Stockpiles may be hauled off or temporarily stored in a protected location off site.
- Keep stockpiles organized and surrounding areas clean.
 - Protect storm drain inlets, watercourses, and water bodies from stockpiles, as appropriate.
 - Implement dust control practices as appropriate on all stockpiled material.
 - **Stockpiles should be covered, stabilized, or protected prior to the onset of precipitation.**
 - Repair and/or replace covers, and perimeter containment structures as needed.
 - Inspect BMPs prior to and after each storm event, daily during extended rain events during the construction and/or clean-up activity (e.g., weekly, or in compliance with the frequency specified in the project specific SWPPP, if applicable). Initiate repairs related to a storm event within 72 hours of identifying the problem or as soon as possible but prior to the next predicted storm event, per the CGP.



Maintenance and Inspection

Pictures



Stockpile covered with plastic and secured with large rocks.



Silt fence used for stockpile perimeter control.

**Corresponding
CASQA
Fact Sheet**

Fact Sheet WM-3



- What** Sediment basins are temporary basins formed by excavation or by constructing an embankment to temporarily detain sediment-laden runoff, allowing sediment to settle out before water leaves the site. The CGP specifies that sediment basins be designed per the CASQA fact sheet SE-2, therefore, this BMP provides general guidance and the CASQA handbook reference.
- When** Sediment basins are appropriate:
- If sediment-laden water may enter a drainage system or watercourse.
 - If areas are disturbed during the rainy season, in association with dikes, temporary channels, and pipes to convey runoff from disturbed areas.
 - To construct before land disturbance, when feasible.
 - In conjunction with erosion controls.
- Where** Sediment basins are suitable on larger projects with sufficient space for the basin, and should be considered:
- Where maintenance is possible year-round.
 - Within property limits, and where failure will not result in loss of life, building damage, or interruption of public roads or utilities.
 - At the outlet of disturbed areas draining generally between 5 and 75 acres, evaluated on a site-specific basis.
 - Where post-construction detention basins are required.
- How** Design the sedimentation basin in accordance with CASQA fact sheet SE-2.
- In general, the basin depth must be no less than 3 feet, not including freeboard, which includes a sediment storage zone and a settling zone of at least 1 and 2 feet deep, respectively.
 - Include features to accommodate overflow or bypass flows that exceed the design storm event.
 - Utilize rock, vegetation, or other erosion control measures to protect the basin inlet, outlet, and slopes against erosion.
 - Continuous fencing should be provided around the sedimentation basin to prevent unauthorized entry.



Maintenance and Inspection

- Inspect BMPs prior to and after each storm event, daily during extended rain events during the construction and/or clean-up activity (e.g., weekly, or in compliance with the frequency specified in the project specific SWPPP, if applicable). Initiate repairs related to a storm event within 72 hours of identifying the problem or as soon as possible but prior to the next predicted storm event, per the CGP.
- Inspect basin banks for seepage and structural soundness.
- Check inlet and outlet structures, spillway, and fencing for damage or obstructions. Repair damage and remove obstructions as needed.
- Remove accumulated sediment when it reaches 1/2 of the basin height or in accordance with the SWPPP requirements. Removed sediment shall be incorporated into the project appropriately or disposed of in accordance with federal, state and local requirements.
- Remove accumulation of any vegetation during every inspection.
- Remove standing water from the basin within 72 hours after accumulation to prevent the production of mosquitoes.
- Completely remove basin when no longer needed. Remove sediment accumulation. Fill and compact excavation, any fencing post-holes and anchor trench, and blend the surface with the adjacent ground.

Pictures

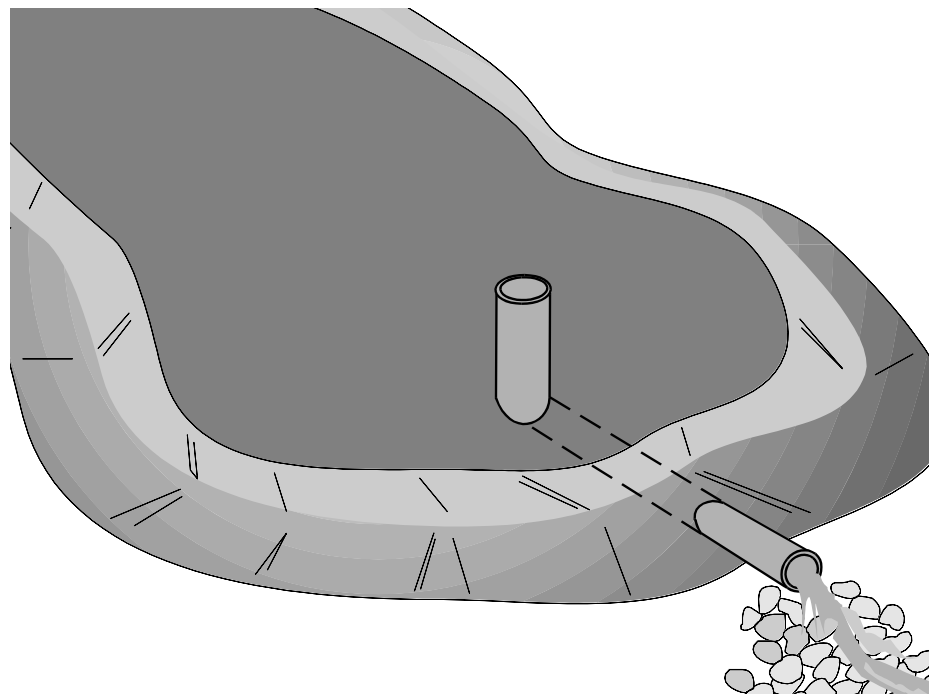

Corresponding CASQA Fact Sheet

Fact Sheet SE-2



What Sediment traps are small, temporary containment areas where sediment-laden runoff is detained, allowing sediment to settle from the runoff before water leaves the site. Sediment traps are formed by excavating or constructing an earthen embankment across a waterway or low drainage area, and usually have a gravel outlet. Sediment traps only remove large and medium-sized soil particles and require upstream erosion control.

When Sediment traps are appropriate:

- If the drainage area is less than 5 acres.
- If sediment-laden water may enter a drainage system or watercourse.
- Construction or operation and maintenance activity occurs in small drainage areas with no unusual drainage features, and short-duration construction activities.
- To construct before land disturbance, when feasible.
- In conjunction with upstream erosion controls.

Where Sediment traps are suitable on sites with sufficient space to allow for infiltration and sediment settling, and should be considered:

- Outside the area being graded, but as near as practical to sediment producing areas, with access for maintenance.
- At the perimeter of a site, at one or more locations where sediment-laden runoff is discharged offsite, to a storm drain or watercourse.
- Around or upslope from storm drain inlet protection measures.
- Within property limits and where failure will not result in loss of life, building damage, or interruption of public roads or utilities.
- **Should not be located in streams unless properly permitted with regulatory agencies. Consult with the Field Environmental Representative.**



How

- Design the sediment trap per referenced engineering standards or local grading ordinance.
- Trap side slopes should be 1:3 (vertical: horizontal) or flatter.
- Trap should be sized to accommodate a settling zone and sediment storage zone with recommended minimum volumes of 67 yd³/acre and 33 yd³/acre of contributing drainage area, respectively, based on 0.5 inch of runoff volume over 24 hours. Larger or multiple traps may be required to accommodate specific rainfall, soil, or site conditions.
- Traps with an impounding levee greater than 4.5 feet tall, measured from the lowest point of the impounding to the highest point of the levee, and traps capable of impounding more than 35,000 ft³, should be designed by a California Registered Civil Engineer.
- The outlet pipe or open spillway must be designed to convey anticipated peak flows.
- When an earth or stone outlet is used, the outlet crest elevation should be at least 1 foot below the top of embankment.
- When a crushed stone outlet is used, the crushed stone or gravel should meet AASHTO M43, size No. 2 or 24, or its equivalent.



- How (cont.)**
- Clear any vegetation under the embankment and pool area.
 - The compacted embankment fill material must be free of roots, vegetation, oversize, or other objectionable material.
 - When a riser is used, all pipe joints must be watertight, and at least the top 2/3 of the riser should be perforated with 0.5-inch diameter holes spaced 8 inches vertically and 10 to 12 inches horizontally.
 - Utilize rock, vegetation, or other erosion control measures to protect the trap outlets against erosion.
 - Fencing should be provided around the trap to prevent unauthorized entry.
- Maintenance and Inspection**
- Inspect BMPs prior to and after each storm event, daily during extended rain events during the construction and/or clean-up activity (e.g., weekly, or in compliance with the frequency specified in the project specific SWPPP, if applicable). Initiate repairs related to a storm event within 72 hours of identifying the problem or as soon as possible but prior to the next predicted storm event, per the CGP.
 - Inspect trap banks for seepage and structural soundness.
 - Inspect outlet structures, spillway, and fencing for any erosion, damage, or obstructions. Repair damage and remove obstructions as needed.
 - Remove accumulated sediment when it reaches one third of the trap capacity. Removed sediment shall be incorporated in the project appropriately or disposed of in accordance with federal, state and local requirements.
 - Remove accumulation of any vegetation during every inspection.
 - Water suitable for mosquito production may stand in the sediment trap, particularly if subjected to daily non-storm water flows. Remove standing water from the trap 72 hours after accumulation.
 - Remove trap when no longer needed. Remove sediment accumulation, fill and compact excavation, any fencing post-holes, and blend the surface with adjacent ground.
 - BMPs that require dewatering shall be continuously attended during dewatering. Dewatering BMPs shall be implemented at all times during such activities.

Pictures

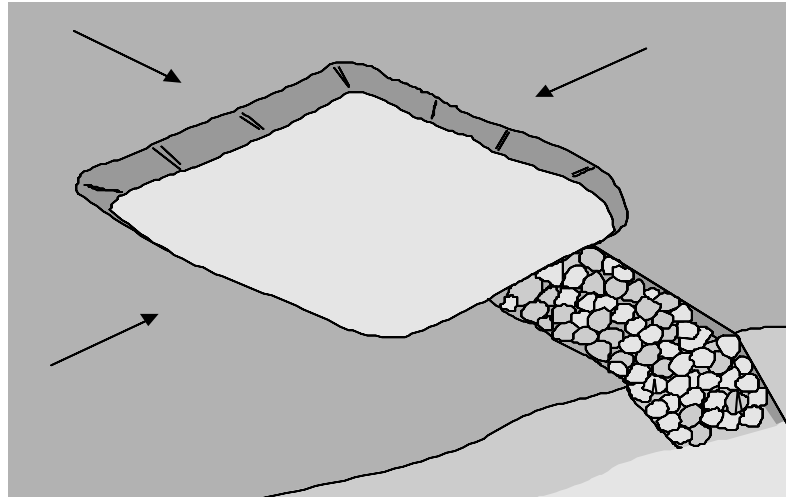

**Corresponding
CASQA
Fact Sheet**

Fact Sheet SE-3



What Check dams are small barriers constructed of rock, logs, gravel bags, sandbags, fiber rolls, or other suitable materials, placed across a swale or drainage ditch. Check dams create small pools and reduce the effective slope of the channel, reducing scour and erosion by reducing flow velocity and increasing residence time within the channel. Check dams promote sediment trapping.

When Check dams are appropriate:

- If sedimentation should be promoted behind the dam.
- If erosion protection is desired in small intermittent channels and temporary swales.
- During the establishment of grass linings in drainage ditches or channels.
- If grade control is desired or required.

Where Check dams should be considered:

- In small open channels that drain 10 acres or less.
- In channels to reduce slope and storm water runoff velocities.
- In temporary ditches where the short length of service does not warrant establishment of erosion-resistant lining.



Check dams should not be used:

- **In streams or in channels with flow between storm events.**
- In channels that are already grass-lined, unless erosion potential or sediment-laden flow is expected. Installation of check dams may damage vegetation.

How

- Do not construct check dams with straw bales or silt fence, since concentrated flows quickly wash out these materials.
- Check dams reduce the capacity of the ditch or swale. Alternative BMPs or an increased swale or ditch size may be necessary or the size of the ditch or swale may need to be increased to prevent overtopping.
- Maximum slope and velocity reduction is achieved when the toe of the upstream dam is at the same elevation as the top of the downstream dam. The center section of the dam should be lower than the edge sections (at least 6 inches), acting as a spillway, so that the check dam will direct flows to the center of the ditch or swale.
- The check dam should be installed along a level contour and should completely span the ditch or swale to prevent washout.
- Install the first check dam approximately 16 feet from the outfall device and at regular intervals based on slope gradient and type.
- Check dams should be placed at a distance and height to allow small pools to form between each check dam.
- For multiple check dam installation, backwater from a downstream check dam should reach the toe of the upstream check dam.
- High flows (typically a 2-year storm or larger) should safely flow over the check dam without an increase in upstream flooding or damage to the check dam.



How (cont.)

- Rock check dams are usually constructed of 8 to 12 inch rock placed individually by hand or mechanically, but never dumped. The rock used should be large enough to stay in place given the expected channel flow. Abutments should be extended 18 inches into the channel bank. Rock can be graded such that smaller diameter rock (2 to 4 inches) is located on the upstream side of larger rock, increasing residence time.
- Log check dams are usually constructed of 4 to 6 inch diameter logs installed vertically, and embedded at least 18 inches into the soil, and can be bolted or wired.
- See BMP 1-03 for installation of fiber roll check dams. Fiber rolls should be trenched in, backfilled, and firmly staked.
- Gravel bag and sand bag check dams are constructed by stacking bags across the ditch or swale. Gravel bags and sand bags used to construct check dams should conform to the requirements of BMP 1-04 and 1-05, respectively. Tightly abut bags and stack in a pyramid fashion no higher than 3 feet. Upper rows shall overlap joints in lower rows.
- Manufactured products used to construct check dams should be installed in accordance with the manufacturer's instructions, and typically requires trenching or anchoring.
- If grass is planted to stabilize the ditch or swale, the check dam should be removed when the grass has matured, unless the slope of the swale is greater than 4 percent.

Maintenance and Inspection

- Check dams require extensive maintenance following high-velocity flows.
- Inspect BMPs prior to and after each storm event, daily during extended rain events during the construction and/or clean-up activity (e.g., weekly, or in compliance with the frequency specified in the project specific SWPPP, if applicable). Initiate repairs related to a storm event within 72 hours of identifying the problem or as soon as possible but prior to the next predicted storm event, per the CGP.
- Replace missing, damaged, or degraded rock, bags, rolls, etc.
- If the check dam is used as a grade control structure, sediment removal is not required as long as the system continues to control the grade.
- Sediment can be re-suspended during subsequent storms or removal of the check dam. Remove accumulated sediment when it reaches 1/3 of the barrier height, and prior to permanent seeding or soil stabilization. Removed sediment shall be incorporated in the project at appropriate locations or disposed of in accordance with federal, state and local requirements.
- Water suitable for mosquito production may stand behind check dams, particularly if subjected to daily non-storm water flows. Remove standing water from the dam 72 hours after accumulation.
- Remove check dam and accumulated sediment when no longer needed.

Pictures

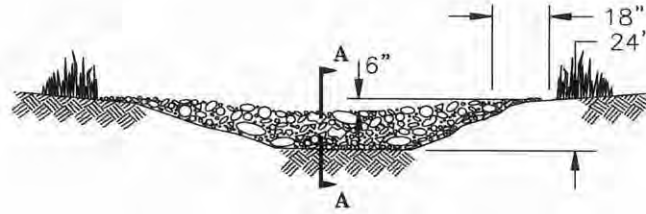

VIEW LOOKING UPSTREAM

NOTE:
 KEY STONE INTO THE DITCH BANKS
 AND EXTEND IT BEYOND THE ABUTMENTS
 A MINIMUM OF 18" TO PREVENT OVER
 FLOW AROUND DAM.

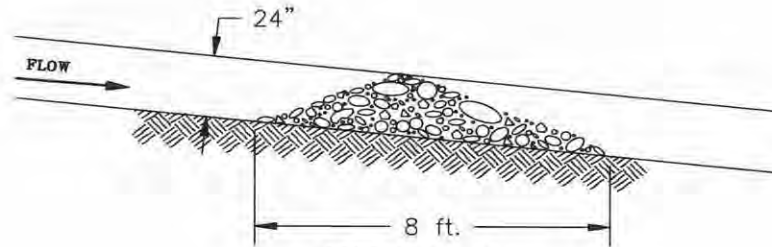

SECTION A - A

'L' = THE DISTANCE SUCH THAT POINTS 'A' AND
 'B' ARE OF EQUAL ELEVATION.

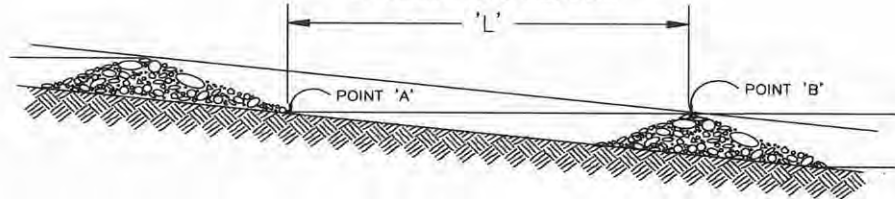

SPACING BETWEEN CHECK DAMS

**Corresponding
 CASQA
 Fact Sheet**

Fact Sheet SE-4



What	Material Delivery and Storage Controls are procedural BMPs controlling the delivery and storage of construction materials, supplies and wastes so that storm water run-on and run-off and non-storm water discharges do not contact the material or wastes.
When	This BMP is applicable when it is necessary to store materials at a construction or operations and maintenance site, and does not apply to materials and supplies stored on trucks that are driven on site and off site daily.
Where	All construction or operations and maintenance activity sites where construction material is delivered or stored and has the potential to be contacted by storm water.
How	Use the following BMP measures as appropriate: <ul style="list-style-type: none">• Only store the minimum amount of material that is needed for the job.• Locate storage areas away from storm drain inlets, drainage systems, and watercourses to prevent storm water run-on from reaching the materials.• If practical, store materials in enclosed storage containers such as cargo containers.• Store materials on impervious surfaces or use plastic groundcovers and berms on bare soil to prevent spills or leakage from contaminating the ground.• For known hazardous materials, keep materials covered using plastic or other waterproof materials.• Store chemicals in water tight containers with appropriate secondary containment systems or in a storage shed to prevent contaminated run-off/run-on from leaving storage areas.• Keep an adequate supply of spill kit materials nearby.• Ensure that qualified personnel are available when hazardous materials are delivered to ensure proper delivery and storage in a designated area.• Material Safety Data Sheets (MSDS) should be made available on-site for all materials stored that have the potential to come in contact with storm water.• When a storage area is no longer needed, return it to original condition.• Bagged materials such as cold patch, concrete mix, and other materials with the potential to pollute runoff should be placed on pallets and covered during non-working days and prior to and during rain events.
Maintenance and Inspection	<ul style="list-style-type: none">• Repair or replace covers, containment structures, or perimeter controls as needed to ensure proper function.• Perform Routine BMP inspections of labels on containers and designated delivery and storage areas.• Inspect BMPs prior to and after each storm event, daily during extended rain events during the construction and/or clean-up activity (e.g., weekly, or in compliance with the frequency specified in the project specific SWPPP, if applicable). Initiate repairs related to a storm event within 72 hours of identifying the problem or as soon as possible but prior to the next predicted storm event, per the CGP.

Pictures



Materials are covered and neatly stored within a curbed area.

**Corresponding
CASQA
Fact Sheet**

Fact Sheet WM-1



- What** Material Use is a procedural BMP that controls the amount or use of materials, chemicals and/or hazardous substances stored onsite and minimizes their potential for contact with storm water run-on or runoff or by non-storm water discharges.
- When** Apply the Material Use BMP when the following materials are used or prepared on site:
- Pesticides (herbicides, insecticides, and biocides).
 - Fertilizers and soil amendments.
 - Detergents.
 - Petroleum products such as fuel, oil, and grease.
 - Asphalt and other concrete components.
 - Hazardous chemicals such as acids, lime, glues, adhesives, paints, solvents, and curing compounds.
 - Mastic, pipe wrap, primers, and paint.
 - Concrete compounds.
 - Welding material.
 - Other materials that may be detrimental if released to the environment.
- Where** All construction and operations and maintenance activity sites that utilize the above materials.
- How**
- Only use products or materials onsite that have been approved through the SDG&E Product Approval process.
 - Reduce or eliminate use of hazardous materials on site when practical. Contact your Field Environmental Representative for additional information.
 - Do not remove the original product label; it contains important safety and disposal information. Use the entire product before disposing of the container.
 - Thoroughly dry empty latex paint cans, used brushes, paint rags, absorbent materials, and drop cloths. These dry wastes may be disposed of with other construction debris.
 - When possible, mix paint indoors, otherwise use secondary containment structures. Do not clean paintbrushes or rinse paint containers into a street, gutter, storm drain, sanitary sewer or watercourse.
 - Dispose of any paint thinners, residue, and sludge that cannot be recycled as hazardous waste (see BMP 2-05). For water-based paint, clean brushes to the extent practical, and rinse into a concrete washout pit or temporary sediment trap. Do not allow liquid to discharge to a storm water conveyance system. For oil-based paints, clean brushes to the extent practical and filter and reuse thinners and solvents.
 - If possible, recycle residual paints, solvents, non-treated lumber, and other materials.
 - **Do not over-apply fertilizers, pesticides, and soil amendments. Prepare only the amount needed. Strictly follow the recommended usage instructions.**





How (cont.)

- For termiticide applications (termite control pesticide) refer to CASQA Fact Sheet WM-2 "Material Use." Note that termiticide can only be applied when it is done in accordance with all applicable federal, state and local labeling requirements and in no case shall it be applied in a manner that would result in either a direct or indirect (e.g., drift) discharge to waters of the US or state.
- Keep an ample supply of spill cleanup material near use areas. Instruct employees in spill cleanup procedures.

Maintenance and Inspection

- Spot-check employees and contractors regularly throughout the job's duration to ensure appropriate practices are being employed.
- Inspect BMPs prior to and after each storm event, daily during extended rain events during the construction and/or clean-up activity (e.g., weekly, or in compliance with the frequency specified in the project specific SWPPP, if applicable).

Pictures

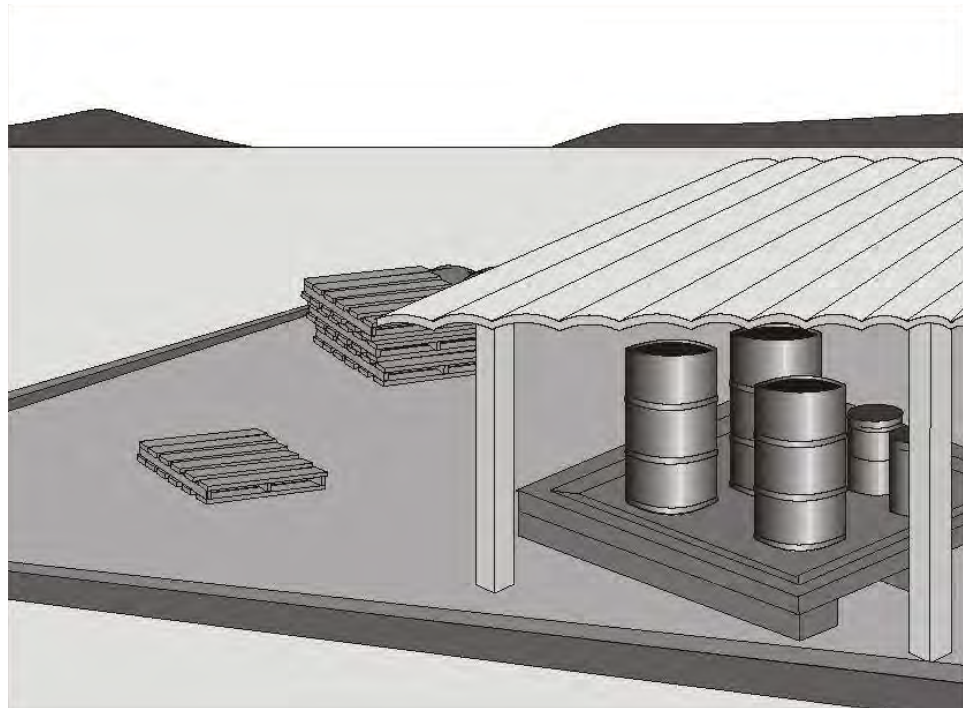

Corresponding CASQA Fact Sheet

Fact Sheet WM-2



- What** Spill Control is a procedural BMP used to control, contain, and clean-up spills on site so that storm water run-on and runoff and non-storm water discharges do not become contaminated.
- When** This BMP applies to all personnel present at construction and operations and maintenance activity sites at all times. Spill control procedures are implemented anytime chemicals (liquid or solid form) and/or hazardous materials and/or wastes are handled, used or stored. A single handling, use, or storage of a hazardous material or waste is sufficient to trigger this requirement. Such substances may include, but are not limited to fuels, lubricants, solvents, fertilizers, pesticides, herbicides, soil binders, coolants, paints, and sewage.
- To the extent that work can be accomplished safely, spills of materials or chemicals shall be contained and cleaned up immediately.
- Where** All construction and operations and maintenance activity sites where chemicals and/or hazardous materials and/or wastes are handled, used, or stored.
- How**
- Install and maintain spill control and cleanup kits in areas where any chemicals and/or hazardous materials and/or waste are handled, used and/or stored.
 - Construction Supervisor, Crew Foreman, or Facility Supervisor and sufficient onsite personnel should be trained in spill control to address potential spills on the site.
 - Only staff trained on spill response procedure should be used to control spill.
 - If the spill is a threat to life or the environment, or other emergency situation where emergency medical support, fire department response, or outside assistance is needed, ***immediately*** call the **911** Operator and the local emergency response agency (usually the local fire department). Then, promptly call **Service Dispatch (Trouble) @ (619) 725-5100** and your supervisor.
 - For all spills ***immediately*** notify the activity and site supervisor ***and/or*** the Field Environmental Representative and describe the spill and current situation. The Field Environmental Representative will make any required regulatory agency notifications per Environmental Standard (ES) G7841 and the Company's Release Reporting Scenario Guidance available on the Environmental Services Department website.
 - If possible, and if you have proper training and personal protective equipment, stop the flow of the spill. If it can be done safely, contain the spill to a confined area. Containment may be able to be accomplished with:
 - Earthen berms
 - Sand bags
 - Absorbent booms
 - Absorbent socksContainment material on site as part of the Spill Kit should reflect site characteristics. For guidance, request assistance from the Field Environmental Representative.
 - To the extent that it doesn't compromise cleanup activities, spills shall be covered and protected from storm water run-on/-off during rain events.



How (cont.)

- Immediately clean the impacted area, and properly dispose of any impacted materials.
 - Spills shall not be buried, except as necessary for immediate interim containment purposes. Spilled material and impacted burial material must be removed as soon as possible after proper control and containment and properly disposed of.
 - Use absorbent materials on spills to thoroughly clean up the material to the maximum extent possible. Spills shall not be diluted with water or other liquid for purposes of mitigating the spill (the solution to pollution is not dilution). When it is necessary to use water or other liquid for final cleaning and decontamination of a spill, the water or other liquid shall not be allowed to enter storm drain inlets, drainages, or watercourses, and shall be collected and disposed of properly. Coordinate disposal of these wastes with the Field Environmental Representative.

Used clean up materials, contaminated materials, and recovered spill material shall be stored and disposed of in accordance with federal, state and local regulations and BMP 2-05 "Hazardous Materials/Waste Management."

Maintenance and Inspection

- Perform routine inspections to verify that spill control clean-up materials are located near material storage, unloading, and use areas prior to and after each storm event, daily during extended rain events during the construction and/or clean-up activity (e.g., weekly, or in compliance with the frequency specified in the project specific SWPPP, if applicable).

Pictures

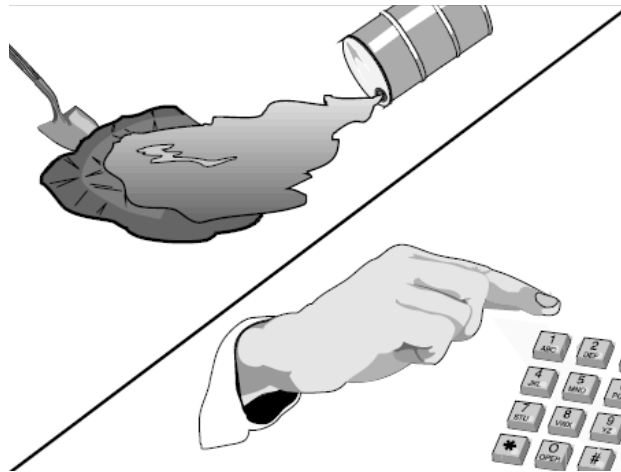

Corresponding CASQA Fact Sheet

Fact Sheet WM-4



What	<p>Solid Waste Management is a procedural BMP used to minimize site non-hazardous solid waste generation, and control the contact of site non-hazardous solid waste with storm water or non-storm water runoff.</p> <p>Examples of potential solid wastes requiring management control BMPs include, but are not limited to:</p> <ul style="list-style-type: none">• Concrete, cement, asphalt rubble, masonry brick/block.• Vegetation debris, general trash, and materials used to transport and package construction materials.• Steel and scrap metals, pipe, electrical cuttings and equipment parts.• Hazardous Materials/Waste Management is covered in BMP 2-05.
When	<p>During all phases of construction or operations and maintenance activities</p>
Where	<p>These BMPs should be used on all construction projects and operations and maintenance activities that generate solid waste.</p>
How	<ul style="list-style-type: none">• Practice good housekeeping and keep site clean.• Use dry methods for site cleanup such as sweeping, vacuuming and hand pick-up.• Designate a waste storage area on site. If a designated waste storage area is not feasible, remove wastes from the site regularly.• Prohibit littering by employees, contractors and visitors.• Trash receptacles with lids or weatherproof covers should be available on site and/or on construction vehicles.• Cover or close lids of all waste containers at the end of each day and prior to rain.• Protect wastes from being washed away by rain, storm water run-on, or other waters (irrigation, water line breaks, etc.).• To prevent storm water run-on from contacting stored solid waste (stockpiled materials) use berms, secondary containment, covered dumpsters/roll-offs or other temporary diversion structure or measures (BMP 1-08 "Stockpile Management").• For materials with the potential for spills or leaks, stockpile the material on impervious surfaces or on plastic groundcovers to prevent spills or leaks infiltrating the ground.• Do not hose out or clean out dumpsters or containers at the construction site.• Prevent solid waste and trash from entering and clogging storm drain inlets.• As practical, incorporate any removed clean sediment and soil back into the project.
Maintenance and Inspection	<ul style="list-style-type: none">• Collect site trash regularly, especially before rainy or windy conditions. Perform routine inspections of site, including storage areas, dumpsters, stockpiles and other areas where trash and debris are collected prior to and after each storm event, daily during extended rain events during the construction and/or clean-up activity (e.g., weekly, or in compliance with the frequency specified in the project specific SWPPP, if applicable). Close trash can lids and dumpster covers at the end of each day and before rainy or windy conditions.

**Corresponding
CASQA
Fact Sheet**

Fact Sheet WM-5



What Hazardous Materials/Waste Management is a procedural BMP for the use, control, containment, and disposal of hazardous materials and waste. This BMP is to be used in conjunction with SDG&E Environmental Standard (ES) G 8724 Hazardous Materials/Waste Management.

Examples of potential hazardous materials and waste requiring management control BMPs may include, but are not limited to:

- Petroleum products such as oil, fuel, grease, cold mix, and tar.
- Glues, adhesives, and solvents.
- Herbicides, pesticides, and fertilizers.
- Paints, stains, and curing compounds.
- Other hazardous or toxic substances.

When Use this BMP during all phases of construction or operations and maintenance activity when the activity involves the storage and use of hazardous materials, or the generation of hazardous waste byproducts.

Where All applicable construction and operations and maintenance activity sites where hazardous materials are used and/or hazardous waste is generated. A single instance of handling, use, or storage of a hazardous material or waste is sufficient to trigger this requirement.

How Hazardous materials and hazardous wastes shall be managed in accordance with the following procedures:

- Only use products or materials onsite that have been approved through the SDG&E Product Approval process.
- Minimize the amount of hazardous materials stored at the site and the production and generation of hazardous waste at the site.
- Cover or containerize and protect from vandalism and exposure any hazardous materials and hazardous wastes.
- Clearly mark all hazardous materials and hazardous waste containers per the ES. Place hazardous waste containers in watertight storage sheds for hazardous waste containers. Alternately, use secondary containment systems, but watertight storage sheds are preferred when hazardous waste containers are stored at the construction site.
- Hazardous materials and hazardous waste containers must meet DOT type and specifications per the ES. The containers must be closed (hand tightened) during activity hours and securely tightened during non-activity hours.
- Stockpiled cold mix should be placed on and covered with plastic.
- Mixing of waste materials is strictly prohibited.
- Storm water that collects within secondary containment structures must be inspected prior to being discharged to ensure no pollutants, oil sheens or non-stormwater discharges are present.
- Spills cannot be discharged to the environment from secondary containment (see BMP 2-03 "Spill Control").



How (cont.)

- All secondary containment systems for hazardous materials or hazardous wastes must be able to hold the volume of the largest container in the storage area and, if uncovered, sufficient additional capacity for storm events. A general rule of thumb for Southern California is that the additional containment volume for an anticipated rain event can be approximated by adding at least an additional four inches (a 4-inch rain) to the height of the containment sized for the entire waste volume of the largest container (Based on the Los Angeles Area 10 year, 24 hour precipitation frequency and a 24-hour manned facility). However, even within Southern California, this varies by the geographic region precipitation frequency and the hours of operation of the facility (containment inspection frequency). Consult with your Field Environmental Representative for determining the minimum volume required for the specific situation and geographical location.



- Hazardous waste must be segregated from other solid waste and stored and disposed of properly according to the ES. **Only company approved vendors with current contracts in place will be used to manage or dispose of hazardous wastes.**
- In addition to following this BMP and ES G8724, employees or contractors are responsible for compliance with federal, state, and local laws and regulations regarding storage, handling, transportation, and disposal of hazardous waste.

Maintenance and Inspection

- Routinely inspect the covers on hazardous material storage areas for tears or flaws and repair as necessary. Drums and drum storage areas are to be inspected at least weekly and the results recorded on an inspection log.
- All secondary containment systems for hazardous materials or hazardous wastes must be able to hold the volume of the largest container in the storage area and, if uncovered, sufficient additional capacity for storm events. A general rule of thumb for Southern California is that the additional containment volume for an anticipated rain event can be approximated by adding at least an additional four inches (a 4-inch rain) to the height of the containment sized for the entire waste volume of the largest container. Check with your Field Environmental Representative in the event you are unsure whether sufficient secondary containment exists for any facility.
- Inspect BMPs prior to and after each storm event, daily during extended rain events during the construction and/or clean-up activity (e.g., weekly, or in compliance with the frequency specified in the project specific SWPPP, if applicable) to ensure that no hazardous materials or waste are improperly left exposed to storm water. Immediately initiate repairs related to a storm event and no later than within 72 hours of identifying the problem or as soon as possible but prior to the next predicted storm event.

Corresponding CASQA Fact Sheet

Fact Sheet WM-6



What	Contaminated Soil Management is a procedural BMP for the control of contaminated soils, or soils suspected of being contaminated, that are encountered during site activities. Importation of fill shall also be managed in accordance with G8755 Import Fill Materials for Large Projects (>100 Cubic Yards), Projects within Coastal Zone, and Environmentally Sensitive Areas.
When	This contaminated soil management BMP should be used whenever soil is imported for fill, soil contamination is suspected, or when contaminated soil is encountered during construction or operation and maintenance “construction like” activities. Construction crews should be vigilant when projects are located in highly urbanized or industrial areas or in highway or roadway right-of-ways.
Where	All construction or “construction like” activity sites, but especially construction and operation and maintenance sites in urbanized or industrial areas where soil contamination may have occurred because of spills, illicit discharges, and leaks from underground storage tanks. Contaminated soils may also be encountered during digging and trenching activities on highway and roadway right-of-ways.
How	<p>Contaminated soil (including soil import that may be contaminated) should be managed in accordance with the following procedures:</p> <ul style="list-style-type: none">• Identify contaminated soil by looking for the following:<ul style="list-style-type: none">○ Soil that is discolored, black, gray, white; or○ Soil that has an unusual odor, such as, petroleum, acid, alkaline, sewage, solvent, or any other chemical smell.• If any potentially contaminated soil is detected, immediately discontinue the activity and contact the project’s Field Environmental Representative.• The CGP requires that the discharger sample and test contaminated soils to ensure proper handling and notify the appropriate local, State and federal agencies, as well as the appropriate Regional Water Board if there is a reportable release event. A reportable release is a discharge or release of oil, hazardous materials or wastes, hazardous substances or chemicals in quantities that may be harmful to the public health. This includes non-stormwater discharges of any kind into the stormwater conveyance system.• Contaminated soils must also be managed properly per SDG&E Environmental Standards (ES). See ES G8729; G8724; and G8755.
Maintenance and Inspection	<ul style="list-style-type: none">• Inspect all imported fill for contamination per Environmental Standard G8755.• Perform routine inspections of digging and trenching operations during construction and operation and maintenance activities looking for contaminated soils in addition to normal BMP inspections prior to and after each storm event, daily during extended rain events during the construction and/or clean-up activity (e.g., weekly, or in compliance with the frequency specified in the project specific SWPPP, if applicable). Immediately initiate repairs related to a storm event no later than within 72 hours of identifying the problem or as soon as possible but prior to the next predicted storm event, per the CGP.• All contaminated soils must be managed properly in accordance with applicable federal, state, and local laws and regulations.

**Corresponding
CASQA
Fact Sheet**

Fact Sheet WM-7



What	Sanitary/Septic Waste Management is a procedural BMP for the control of sanitary/septic wastes. Sanitary/Septic waste is domestic (human) waste.
When	When construction or operation and maintenance site location requires onsite sanitary/septic waste portable toilets, or hand wash/rinse stations, or shower units.
Where	All applicable construction and field operations and maintenance sites.
How	<p>Sanitary/septic wastes shall be managed in accordance with the following procedures:</p> <ul style="list-style-type: none">• Incorporate into regular safety meetings the education of employees, contractors, and suppliers on:<ul style="list-style-type: none">○ Potential dangers to humans and the environment from contact with sanitary/septic wastes due to bacteria, viruses, and parasites.○ Approved sanitary/septic waste storage and disposal procedures.• Use only reputable, licensed sanitary/septic waste facility providers and haulers for sanitary facilities (portable toilets, hand wash stations, shower units) and their transportation to and from the construction site.• Ensure that sanitary facilities are equipped with secondary containment to prevent discharge of pollutants to the storm water drainage system or receiving water.• Sanitary facilities should be located away from drainage systems and watercourses, minimizing the likelihood of leaks or spills contaminating waterways.• Sanitary facilities should be located away from highways and roadways to avoid vehicles colliding with the sanitary units.• When subjected to high winds, risk of high winds, or risk of vandalism, sanitary facilities shall be secured to prevent overturning.• Sanitary wastewater should not be buried or discharged, except to a properly permitted sanitary sewer discharge facility. A permit may be required from the local Sanitation District.• Temporary sanitary facility's holding tanks shall be emptied by a licensed waste hauler prior to transport.
Maintenance and Inspection	<ul style="list-style-type: none">• Perform inspections of sanitary facilities and BMPs routinely prior to and after each storm event, daily during extended rain events during the construction and/or clean-up activity (e.g., weekly, or in compliance with the frequency specified in the project specific SWPPP, if applicable). Initiate repairs related to a storm event within 72 hours of identifying the problem or as soon as possible but prior to the next predicted storm event, per the CGP.• Ensure that sanitary/septic facilities are maintained in good working order and routinely serviced by a licensed service.• When servicing of portable sanitary facilities is conducted, wash/rinse water shall, not be allowed to runoff and shall be collected and disposed of properly in accordance with federal, state, and local requirements.

Pictures

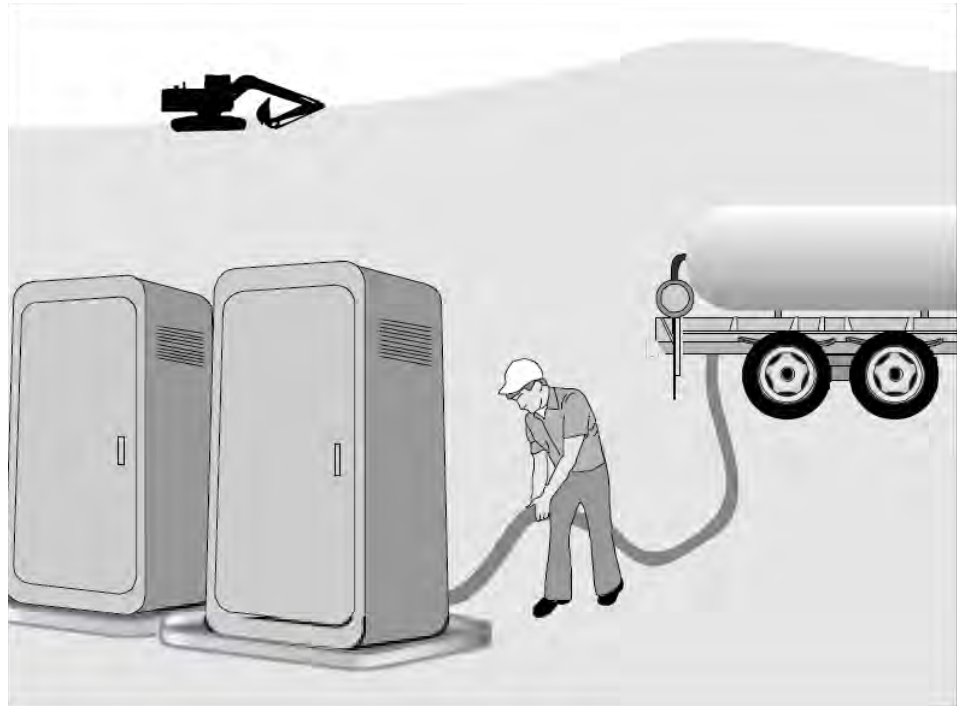

**Corresponding
CASQA
Fact Sheet**

Fact Sheet WM-9



- What** Non-hazardous Liquid Waste/Drilling Fluid Management is a procedural BMP for managing non-hazardous liquid wastes on a construction or operation/maintenance activity site.
- Hazardous liquid wastes, including water with an oily sheen, should be managed using BMP 2-05 "Hazardous Materials/Waste Management."
- Dewatering operations, and concrete slurry residue should be managed according to BMP 3-01, and BMP 3-05, respectively.
- Non-hazardous Liquid wastes include, but are not limited to:
- Drilling slurries/muds and fluids, and waste water and rinse water without an oil sheen (including pressure washing).
 - Dredging spoil, and non-storm water liquid discharges that do not have discharge permits.
- When** Liquid waste management is applicable when construction projects and operations and maintenance activities generate any non-hazardous liquid byproducts, residuals,, or wastes.
- Where** All applicable construction and operations and maintenance sites where non-hazardous liquid waste is present.
- How**
- Vehicle and equipment cleaning using water is discouraged on site. If washing is required for safety or for the work, utilize BMP 3-03 "Vehicle and Equipment Washing."
 - Drilling residue and drilling fluids should be disposed of in accordance with federal, state and local requirements. Coordinate the disposal of these wastes with your Field Environmental Representative.
 - Wastes generated as part of a construction, operation, or maintenance procedure, such as water laden with dredged material and drilling mud should be contained and not allowed to flow into drainage channels, storm drains, or receiving waters.
 - Contain non-hazardous liquid wastes in a controlled area and manner, such as a lined pit, lined roll-off bin with a sealed bottom, or a portable tank.
 - Storage tanks used for collecting and settling non-hazardous water shall be routinely checked for leaks and to ensure they are not overfilled.
 - Piping used to connect storage tanks shall be routinely checked to ensure connections are secure and not leaking.
 - Containment devices must be of sufficient quantity or volume to completely contain the liquid wastes generated and, if uncovered, any additional volume needed for anticipated precipitation. A general rule of thumb for Southern California is that the additional containment volume for an anticipated rain event can be approximated by adding at least an additional four inches (a 4 inch rain) to the height of the containment sized for the entire waste volume. Contained material must be routinely removed and properly disposed of in accordance with federal, state and local requirements.
 - **Do not locate containment areas or devices where accidental release of the contained liquid can threaten health or safety, or discharge to watercourses, storm drain system, or to a water body.**
 - Capture all liquid wastes running off a surface including wash water and rinse water from cleaning walls or pavement, including pressure washing.





How (cont.)

- If the liquid waste is sediment laden, use a sediment trap (see BMP 1-10) or capture in a containment device and allow sediment to settle.
- Disposal of liquid wastes are subject to specific laws and regulations, or to requirements of other permits secured for the construction project. Contact your Field Environmental Representative for further information.

Maintenance and Inspection

- Remove deposited solids from containment areas and containment systems as needed, and at the completion of the project. Soil, dredged material and drilling mud to be transported offsite for reuse or disposal must first be profiled using chemical analysis. Liquid waste disposal may also need to be profiled prior to transportation and disposal. Contact the Field Environmental Representative as far in advance of the anticipated transportation need as possible.
- Inspect containment systems routinely for damage, and repair as needed.
- BMPs prior to and after each storm event, daily during extended rain events during the construction and/or clean-up activity (e.g., weekly, or in compliance with the frequency specified in the project specific SWPPP, if applicable). Initiate repairs related to a storm event within 72 hours of identifying the problem or as soon as possible but prior to the next predicted storm event, per the CGP.

Pictures

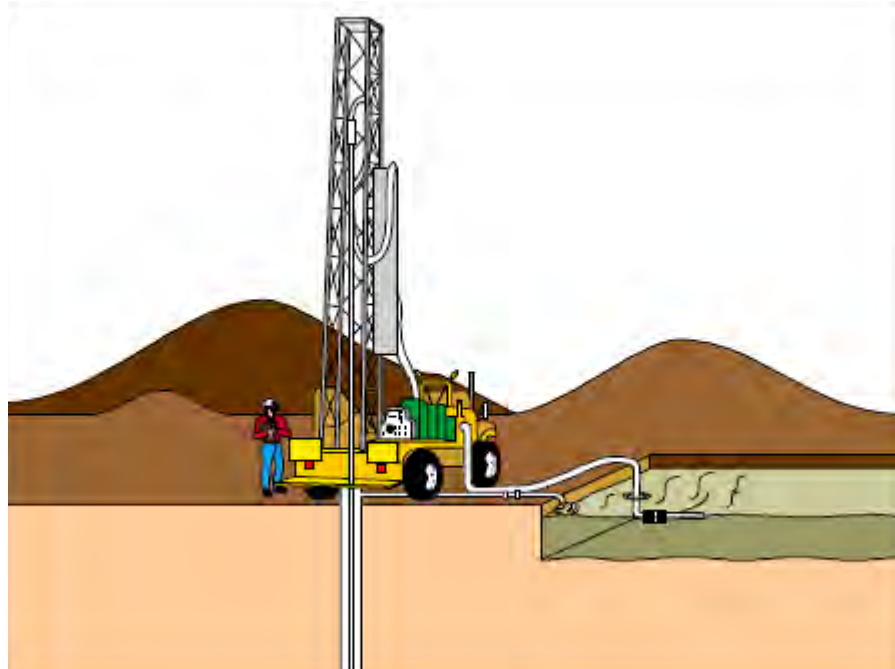

Corresponding CASQA Fact Sheet

Fact Sheet WM-10



What Dewatering Operations is a procedural BMP for controlling construction or operations and maintenance dewatering to assure regulatory compliance.

- When**
- This BMP is applicable when groundwater from an excavation, trench, or non-storm water from a pipeline hydrostatic test must be removed.
 - When excavation/trench dewatering, also see Environmental Standard (ES) 104.0226.
 - When dewatering hydrostatic test water, also see ES 104.0220.
 - **This BMP is not Applicable to drilling mud or similar products used in drilling foundations (see BMP 2-08 "Non-hazardous Liquid Waste/Drilling Fluid Management")**
 - **This BMP is not applicable to utility vault or sub-structure dewatering. For these applications, refer to the BMP 3-06 "Dewatering Utility Substructures and Vaults."**
 - **This BMP is not applicable when the water is known, or suspected to be, contaminated. Under these conditions, contact your Field Environmental Representative.**
 - **Water from dewatering operations cannot be discharged to the sanitary sewer, storm drain systems, drainages, creek beds (even if dry), or to water bodies without a permit. This prohibition includes groundwater dewatering to these conveyance systems or water bodies (groundwater may contain pollutants not easily detected except by analytical laboratory tests).**
 - **Groundwater from excavation or trench dewatering or hydrostatic test water cannot be discharged to land without a permit or permit waiver. Groundwater and hydrostatic test water may contain pollutants not easily detected except by analytical laboratory tests.**
 - Non-contaminated discharges of water from hydrostatic tests of new pipe utilizing potable water as a water source, reused for soil compaction and dust control, or reused for agricultural irrigation may be allowed to be discharged to land without a permit or under a permit waiver, depending on the local and regional regulatory requirements. Consult with your project Field Environmental Representative for permitting applicability prior to planning a discharge.

IMPORTANT POINT

Where All construction sites and operations and maintenance activity sites that require excavation or trench dewatering, or pipe hydrostatic test discharges.

How Water generated by dewatering activities should be managed in accordance with the following procedures:

- If allowed by regulations, permit, or the regulating agencies, use the water for construction activities such as onsite soil compaction and dust control. If used for these applications, ensure that the water does not run-off to storm drain systems, drainages, creek beds (even if dry), or to water bodies.
 - The water may contain uncontaminated sediments, but the water must not be contaminated with other pollutants.

Note: Discharge to land for site compaction, dust control or for infiltration (to groundwater) may require a permit or permit waiver to discharge from the Regional Water Quality Control Board (RWQCBs) and/or local jurisdictions (such as Flood Control District). Consult with your Field Environmental Representative.



How (cont.)

- If allowed by regulations, permit, or the regulating agencies, water from dewatering, that contains only uncontaminated sediment, may be discharged to one of the following:
 - To land for infiltration (also see soil compaction and dust control above). In some locations, a permit may be required from the RWQCB and/or a local jurisdiction (such as a Flood Control District). Consult with your Field Environmental Representative. The permit may allow sediment without settling or filtration. The permit may specify limits on other pollutants, requiring sampling and analysis, and submittal of analysis results prior to discharge approval. If allowed by regulations, permit, or the regulating agencies, infiltrate to an appropriate landscaped, vegetated, or soil area. If used for these applications, ensure that the water will infiltrate and not run-off to storm drain systems, drainages, creek beds (even if dry), or to water bodies. Land owner permission to discharge to land for infiltration is required.
 - To the Sanitation or Wastewater District Sanitary/Industrial Sewer - Requires a permit or approval of the above wastewater authority. District may require sampling and analysis and a Batch Discharge application (application for a short-term discharge of a stated volume) prior to approval. District may set a numeric limit on the amount of acceptable sediment discharged. District may require a fee, dependent on discharge volume and pollutant load.
 - To Surface Water (including storm drains) - A RWQCB discharge permit is required and a local jurisdiction permit (such as a Flood Control District permit) may be required. Consult with your Field Environmental Representative. The permit may specify limits on sediment and other pollutants, require sampling and analysis, and the submittal of analysis results prior to discharge approval. These permits take advanced planning.
 - A surface water (including storm drains) discharge permit may have a numerical limit on the concentration of Total Suspended Solids (sediment) that can be discharged and a restriction limiting an increase in turbidity of the receiving water. Other pollutants, such as Oil and Grease (O&G) and Total Petroleum Hydrocarbons (TPH) may also have stringent numerical limits. As a minimum, contaminant-free temporary storage (Baker tanks) may need to be provided until permit coverage is obtained and sampling and analysis can be completed. A properly sized sediment clarifier and petroleum hydrocarbon treatment may be required. The cost of this potential treatment for discharge to surface waters should be compared to the treatment cost of discharging to the sanitary sewer (if logistically feasible) before deciding on this discharge option.
- Transport for Disposal in a Vacuum Truck for Proper Disposal. This option is usually the most expensive option and only utilized when the discharge options above cannot be permitted or is otherwise infeasible.
- If a permit is obtained for discharge to a storm water or sanitary sewer system, conduct all dewatering discharge activities in accordance with permit requirements, including installation of appropriate BMPs.
- Dewatering records should be maintained in accordance with permit requirements.



Maintenance and Inspection

- Inspect pumps, hoses and all equipment before use to ensure they are in proper operating condition and free of contamination. Monitor dewatering operations to ensure it does not cause offsite discharge or erosion.
- Monitor the discharge for any change in characteristics (amount of sediment, oil sheen, color, etc.) that is not permitted. Stop the discharge immediately if there is a visual indication that the permit conditions are being exceeded.
- BMPs prior to and after each storm event, daily during extended rain events during the construction and/or clean-up activity (e.g., weekly, or in compliance with the frequency specified in the project specific SWPPP, if applicable). Initiate repairs related to a storm event within 72 hours of identifying the problem or as soon as possible but prior to the next predicted storm event, per the CGP.
- Sample dewatering discharges in accordance with permit requirements, if applicable.
- These operations and equipment should be made secure.

Pictures

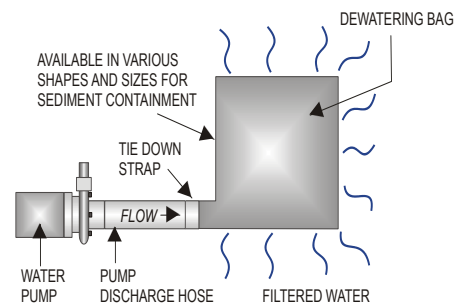

Gravity Bag Filter

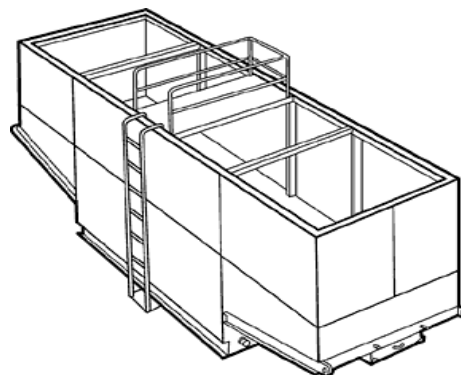

Weir Tank

Corresponding CASQA Fact Sheet

Fact Sheet NS-2



What Paving Operations is a procedural BMP for controlling non-storm water discharges associated with pavement surfacing or resurfacing, patching, or pavement removal.

Paving Operations activities may typically utilize the following materials:

- Cold mix,
- Asphalt,
- Chip Seal, Seal Coat, Tack Coat, Slurry Seal, Fog Seal, and
- Portland Cement Concrete.

For pavement grinding, saw cutting, coring or drilling, refer to BMP 3-05 "Concrete/Coring/Saw cutting and Drilling Waste Management."

When Use this BMP whenever paving operations are being conducted.

Where All construction or operations and maintenance work sites that have paving activities.

How Use the following methods as applicable:

- Protect storm drain inlets near work and down gradient of the area to be paved (see BMP 1-06 "Storm Drain Inlet Protection").
- If onsite mixing is planned, an area must be designated for conducting the mixing. This area should already be paved or made impervious (e.g., plastic or wood sheeting) and be located away from storm drain inlets, drainages, or watercourses.
- Minimize overspray of tackifying emulsions or placement of other paving materials beyond the limits of the area to be paved. Schedule the application of tackifying agents according to manufacturer's instructions regarding rain events.
- Use dry methods to clean equipment and conduct cleaning in accordance with BMP 3-03 "Vehicle and Equipment Washing."
- Material use and stockpiles are to be managed in accordance with BMP 2-02 "Material Use" and BMP 1-08, "Stockpile Management."
- Collect and remove all broken asphalt and concrete, recycle when feasible, and dispose of materials in accordance with local, state, and federal requirements.

IMPORTANT POINT



- **Do not apply asphalt, concrete paving, seal coat, tack coat, slurry seal or fog seal if rain is expected during the application or curing period.**
- **Avoid if possible, the transferring, loading, or unloading of paving materials near storm drain inlets, drainages, or watercourses. If not possible, use BMP 1-06 "Storm Drain Inlet Protection."**
- **CGP Risk Level 2 & 3 projects, that construct concrete structures onsite or store concrete mixing materials onsite, are subject to pH Numeric Action Levels (Risk 2) or pH Numeric Effluent Limits (Risk 3) for those drainage areas of the project where the concrete construction or storage of concrete mixing or waste materials take place.**
- **CGP Type 2 & 3 projects are subject to pH Numeric Action Levels (Type 2) or pH Numeric Effluent Limits (Type 3) for active areas.**
- Inspect and maintain equipment and machinery routinely to minimize leaks.

Maintenance and Inspection

NON-STORM WATER DISCHARGE CONTROLS

Paving Operations

BMP 3-02



Maintenance and Inspection (cont.)

- Inlet protection BMPs prior to and after each storm event, daily during extended rain events during the construction and/or clean-up activity (e.g., weekly, or in compliance with the frequency specified in the project specific SWPPP, if applicable). Initiate repairs related to a storm event within 72 hours of identifying the problem or as soon as possible but prior to the next predicted storm event, per the CGP.

Corresponding CASQA Fact Sheet

Fact Sheet NS-3

NON-STORM WATER DISCHARGE CONTROLS

Vehicle and Equipment Fueling

BMP 3-04



What	Vehicle and Equipment Fueling is a procedural BMP for controlling vehicle and equipment fueling at construction and operation and maintenance activity sites.
When	<p>Use this BMP for construction and operation and maintenance activity sites when onsite fueling of vehicles and equipment, including handheld equipment, is planned or conducted.</p> <p>Vehicle and equipment fueling, except for handheld equipment, is typically not done on a construction site. Onsite fueling of vehicles and equipment may be planned if it is impractical to send vehicles and equipment off site for fueling.</p> <p>Handheld equipment is treated separately from other equipment. Handheld equipment includes those smaller, manually operated pieces of equipment such as trenchers, mowers, chainsaws, generators, and other equipment that need fueling during regular daily operation.</p>
Where	All construction and operation and maintenance activity sites where vehicle and equipment fueling occurs.
How	<ul style="list-style-type: none">• If practical, fuel vehicles and equipment off site.• Mobile fueling equipment is the preferred equipment used for construction site fueling.• Fuel storage and fueling areas should be located away from storm drain inlets, drainage systems, watercourses, and water bodies.• All fueling will be conducted with the fueling operator in attendance at all times regardless if fuel nozzles are equipped with automatic shutoff features.• Fuel tanks should not be “topped off.”• All fueling operators should have readily available spill containment and cleanup equipment and materials.• Clean up spills immediately and properly dispose of contaminated materials.• Properly store and dispose of rags and absorbent material used to clean up spilled fuel.• Mobile fueling trucks and operators must have all necessary permits, licenses and training.
Maintenance and Inspection	<ul style="list-style-type: none">• Check to ensure that there is an adequate supply of spill cleanup materials available.• Perform routine inspections of designated fueling areas and inspect vehicles and equipment for leaks.• Report all spills immediately to the project Supervisor <i>and/or</i> the Field Environmental Representative.

Pictures

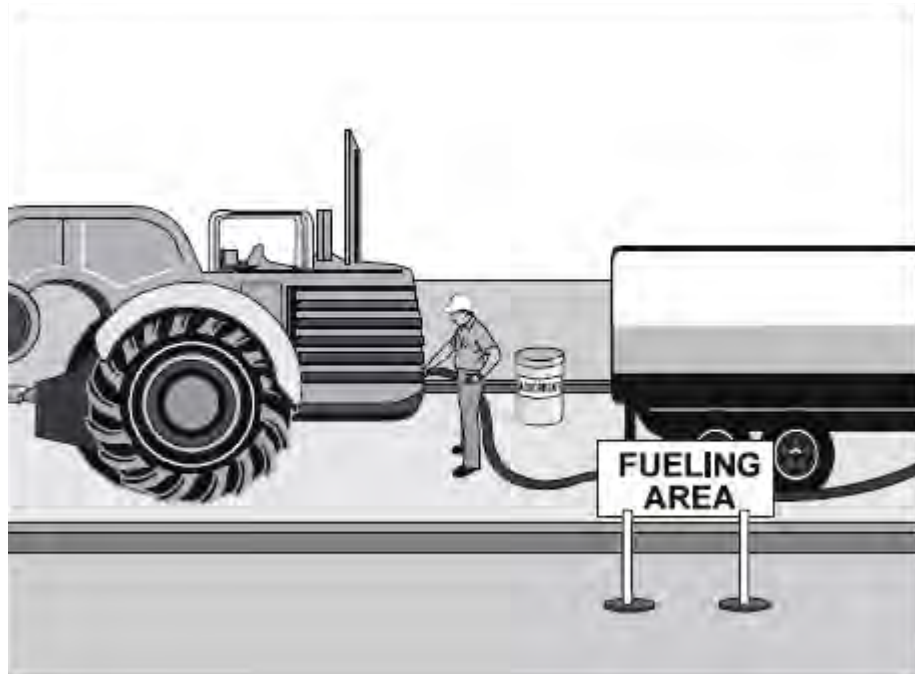

**Corresponding
CASQA
Fact Sheet**

Fact Sheet NS-9

NON-STORM WATER DISCHARGE CONTROLS

Concrete/Coring/Saw Cutting and Drilling Waste Management

BMP 3-05



- What** Concrete/Coring/Saw Cutting and Drilling Waste Controls are procedural BMPs for the proper management of liquid and solid wastes from concrete/coring/saw cutting and drilling activities.
- For managing any concrete curing compounds, also use BMP 2-05 "Hazardous Materials/Hazardous Waste Management." For managing paving operations, use BMP 3-02.
- When** Use this BMP at construction and operation and maintenance activity sites when the activity utilizes concrete and asphalt or when slurry or pavement/concrete wastes are generated by the activities, including:
- Saw cutting.
 - Coring/drilling.
 - Grinding, re-paving or patching.
 - Encasing conduit in concrete.
 - Tower footings.
- Where** All construction and operation and maintenance activity sites where the above activities are conducted.
- How**
- Install storm drain protection at any down-gradient inlets that may be impacted by the activity per BMP 1-06 "Storm Drain Inlet Protection."
 - Minimize the amount of water used during coring/drilling or saw cutting. During wet coring or saw cutting, use a wet vacuum to lift the slurry from the pavement as the coring or saw cutting progresses. Additionally, sand bag barriers or other containment should be used at nearby down gradient storm drain or drainage inlets per BMP 1-06 "Storm Drain Inlet Protection."
 - If concrete residue remains after drying, the area should be swept in a timely manner and residue removed to avoid contact with storm water or entering a storm drain or water body via the wind. If concrete residue still remains, pressure wash the surface, with in-progress vacuum recovery of wash water to remove residual material.
 - **Do not wash residue or particulate matter into a storm drain or drainage inlet or a watercourse or water body.**
 - The following options should be used for concrete truck chute and/or pump and hose washout:
 - If available, arrange to use an existing concrete washout station. Upon entering the site, concrete truck drivers should be instructed about proper site practices.
 - **Concrete Washouts:** Washout stations can be: self contained concrete trucks; commercial portable washout stations (rent-a-washout); plastic lined temporary pits, or a bermed and lined area designed with sufficient volume to completely contain all liquid and waste concrete materials plus enough capacity for rainwater. The lining must be impervious (such as Visqueen with no holes or tears). The designated area must be located away from storm drain inlets, drainages, watercourses, or water bodies.
 - **Washout in Trench:** Manually rinse the concrete truck chute into the lined trench itself. Note that this practice is not allowed on CGP projects, where minimum BMPs in the permit require containment of concrete washout areas and prohibits discharge into the underlying soil or surrounding areas. Check with the Field Environmental Representative regarding site-specific applicability.



NON-STORM WATER DISCHARGE CONTROLS

Concrete/Coring/Saw Cutting and Drilling Waste Management

BMP 3-05



How
(cont.)

IMPORTANT
POINT



**Maintenance
and
Inspection**

**Corresponding
CASQA
Fact Sheet**

- **Bucket Washout:** Manually rinse the chute into a wheelbarrow, plastic bucket or pail, and then empty the bucket into the concrete truck barrel or on top of the placed concrete within a trench or excavation. Prevent or protect against spillage, and clean up any spillage promptly.
- **CGP Risk Level/Type 2 & 3 projects, that construct concrete structures onsite or store concrete mixing materials onsite, are subject to pH Numeric Action Levels (Risk/Type 2) or pH Numeric Effluent Limits (Risk/Type 3) for those drainage areas of the project where the concrete construction or storage of concrete mixing or waste materials take place.**
- Responsible personnel should ensure that all drivers of concrete trucks arriving onsite are instructed about proper project practices.
- Clean out designated washout areas as needed or at a minimum when the washout is 75 percent full to maintain sufficient capacity throughout the project duration. Add additional designated areas as necessary and available to maintain capacity.
- Any designated onsite washout areas must be cleaned out and all debris removed upon project completion. Dispose of concrete waste according to BMP 2-04 "Solid Waste Management."
- Inspect routinely, when washout activities are underway to ensure the integrity of the concrete washout lining and that the concrete washout does not overflow.

Fact Sheet WM-10

NON-STORM WATER DISCHARGE CONTROLS

Dewatering Utility Vaults

BMP 3-06



- What** Dewatering Utility Vaults is a procedural BMP for controlling water from dewatering utility vaults and underground structures. This BMP does not apply to trench, excavation or other general dewatering associated with construction activities, which is covered by BMP 3-01.
- When** This BMP is applicable whenever water must be removed from SDG&E utility vaults and underground structures.
- Where** All SDG&E utility vault locations.
- How** The discharge of clean water from dewatering of vaults and underground structures to the storm drain, drainages, or water bodies is allowed under the statewide General NPDES Permit for Discharges from Utility Vaults and Underground Structures to Surface Waters (Order No. 2006-0008-DWQ and NPDES No, CAG990002).
- Discharges to land (e.g., vegetation, bare soil area) are not covered by this permit. A Waste Discharge Requirements (WDR) permit or waiver may be required by the local Regional Water Quality Control Board (RWQCB) for discharges to land. If a RWQCB does not have a general WDR or waiver for discharges to land, then the State Water Resources Control Board (SWRCB) General Permit for dewatering to land may apply. Consult with your Field Environmental Representative. Discharges to land also require the prior approval from the landowner.
- General requirements for discharge under Order 2006-0008-DWQ/Permit Number CAG990002) are listed below:
- All vault dewatering discharges conducted by utility crews, including contractors, shall follow the latest version of SDG&E's Environmental Standards (ES) on Vault and Underground Structure Dewatering. For dewatering utility gas/electric vaults & underground structures follow ES <http://techdocs.sempira.com/doclib.nsf/docframe?openform&docno=G8718>.
 - Prior to discharge, the water in the vault shall be assessed in accordance with the requirements in the ES.
 - A SDG&E-approved filter system with hydrocarbon removal capability is required to be used on the pump discharge for compliance assurance when dewatering to a surface water (drainage, gutter, storm drain inlet, or a water body).
 - **If the water to be discharged is Clear Water as described in the ES, then the discharge to storm drains, drainages, or water bodies is acceptable as long as the discharge does not cause nuisance or harm to the environment.**
 - Water discharged to the street, gutter, drainages, watercourses, or water bodies must be clean and clear, with no evidence of oil sheen and no chemical or sewage smell.
 - The dewatering discharge must be monitored at all times during the discharge to ensure the discharge is "clean and clear" with no chemical or sewage odor. If the characteristics of the discharge change (i.e., color, smell, sheen), the discharge must be stopped immediately. In such an event call the Field Environmental Representative.
 - Whenever possible, discharge the clean, clear water directly to the storm drain, drainage, or water body to avoid pre-existing pollutants in the discharge path. Pre-existing soil or contaminants in the path of the discharge (i.e., gutter) that can discolor/contaminate the discharge need to be cleaned up before discharging vault water.



NON-STORM WATER DISCHARGE CONTROLS

Dewatering Utility Vaults

BMP 3-06



**IMPORTANT
POINT** 

**How
(cont.)**

- The discharge from the filter system must be clean and clear at all times, and if not, the discharge must be stopped.
- As a last resort, when the water, because of sediment or pollutant contamination, cannot be discharged to the environment, contact the project Field Environmental Representative for transport of the water in an approved manner (see the linked SDG&E ES from the previous page).

**Maintenance
and
Inspection**

- Implement applicable provisions of the ES.
- Inspect pumps, hoses, filter system and equipment before use and routinely when applicable activities are underway.
- Observe dewatering activities to ensure they do not cause erosion or discharge of potential pollutants.

**Corresponding
CASQA
Fact Sheet**

Not applicable. See also Fact Sheet NS-2, Dewatering Operations



What	<p>Over-Water Protection is a procedural and containment system BMP for protecting watercourses from overhead construction and maintenance and repair activities.</p> <ul style="list-style-type: none">• Over-water construction and maintenance activities include, but are not limited to, chipping, grinding, scraping, welding/burning, painting, wrapping and coating of pipes and conduits.• Watercourses (dry or wet) include drainages, creeks, streams, rivers, lakes and wetlands, bays, estuaries and oceans.
When	<p>This BMP applies to projects when:</p> <ul style="list-style-type: none">• Construction, maintenance or repair activities will be conducted above watercourses (dry or wet). <p>Prior to conducting over-water activities, check with the Field Environmental Representative for the possible need for permits with the appropriate local and state agencies. As an example, the design or installation of a containment system may itself impact the watercourse and require a permit, or the timing of the activity may impact wildlife breeding seasons, requiring a permit or preventing the activity during certain portions of the year.</p>
Where	<p>All construction or operation and maintenance activity above any portion of a watercourse.</p>
How	<p>Use the following measures as applicable:</p> <ul style="list-style-type: none">• Containment systems must be properly designed and installed prior to the beginning of any operation that may impact a water body to prevent discharge of pollutants to surface waters, taking into account the construction or maintenance activity and factors such as wind, rain, etc.• The work area should be kept clean of all trash and potential pollutants.• Containment booms should be placed around the area of work as necessary to contain the discharge of potential contaminants such as oil and hydraulic fluid.• Special attention should be given to existing and forecasted wind and weather conditions to prevent pollutant discharges to surface waters.• Shrouds of appropriate material should be used to prevent paint overspray, welding slag, and other pollutants from entering surface waters. Shrouding may not be effective during periods of high wind.• Shrouds should be large enough to adequately enclose or segregate the working area from surface waters. This may include a plywood barrier, Visqueen, and scaffolding to help prevent fugitive material from entering surface waters.• Support structures such as scaffolding shall be used in conjunction with shrouding to withstand potential wind stress.• Contaminated shrouding material and equipment shall be thoroughly cleaned or disposed of properly.
Maintenance and Inspection	<ul style="list-style-type: none">• Inspect the containment systems, shrouds, and support structures prior to and after each storm event, daily during extended rain events during the construction and/or clean-up activity (e.g., weekly, or in compliance with the frequency specified in the project specific SWPPP, if applicable) to ensure their integrity and safety. Initiate repairs related to a storm event within 72 hours of identifying the problem or as soon as possible but prior to the next predicted storm event.

Pictures



**Corresponding
CASQA
Fact Sheet**

Fact Sheet NS-14

NON-STORM WATER DISCHARGE CONTROLS

Paint Removal Control

BMP 3-08



What	Paint Removal Control is a procedural BMP for protecting storm water and water courses from mark-out paint or graffiti paint removal activities.
When	Use this BMP when utility activities have used mark-out paint on surfaces and the paint is required to be removed by local jurisdictions or another authority, or when graffiti on company property is discovered and must be removed.
Where	Mark-out paint is usually used on road, sidewalk, and land surfaces to show the location of underground utility services. Graffiti on company property may have been painted on company fences or walls, buildings, walkways, curbs or other surface.
How	<p>Use the following options to remove mark-out paint or graffiti:</p> <ul style="list-style-type: none">• Use non-toxic, light degradable mark-out paint when possible.• Avoid the use of chemical paint removers whenever possible. When chemical paint removers are required, only use products that have been approved through the product review process and utilize containment and wet vacuuming of material during the removal process.• Hydro pressure wash.• Dry abrasive blast/grinding.• Wet abrasive blast/grinding. <p>Use one or more of the following methods to promptly and effectively contain and remove paint and residues in order to protect storm water sewers, drainages and watercourses:</p> <ul style="list-style-type: none">• Dry sweep.• Install storm drain inlet protection at down gradient inlets during hydro pressure washing, wet abrasive blasting, grinding, and chemical removal. Discharge of any wet or dry residuals or wash water to the drainage system is prohibited.• Minimize the amount of water used during hydro pressure washing.• Wet or dry vacuum.• Use wet vacuum to lift the paint slurry from the pavement or surface as hydro pressure washing progresses or as soon as possible, and before the material has a chance to migrate from the work area.• If wet vacuuming is not adequate to capture all wastewater from these activities, use additional containment (sand bags, booms, or other containment devices) methods as near the work area as possible to prevent the discharge to a street, gutter, storm drain/drainage inlet, or watercourse.• If paint residue remains after drying, the area should be swept up and residue removed in a timely manner to avoid contact with storm water.• If paint residue remains after sweeping, the area can be water washed, as long as the water containing the paint residue is contained near the work and wet vacuumed and not allowed to enter storm drain inlets or watercourses.• All waste should be disposed of using the BMP 2-08 "Non-Hazardous Liquid Waste Management."
Maintenance and Inspection	<ul style="list-style-type: none">• Inspect all containment systems to ensure proper placement prior to starting utility paint removal operations.• Inspect equipment frequently and adjust as necessary to maximize efficiency and minimize water or other material use of the paint removal

NON-STORM WATER DISCHARGE CONTROLS

Paint Removal Control

BMP 3-08



operations.

**Corresponding
CASQA
Fact Sheet**

NA



What

A stream crossing is a culvert, ford, or bridge placed across a waterway to provide access for construction or operations and maintenance activities. Utility stream crossings are not intended to maintain public traffic and project-specific permits may be required for use (see "Limitations"). The crossing design and construction allows safe access and reduces erosion and downstream sediment from vehicles.

The project Field Environmental Representative should be consulted for any permit requirements and for the stream crossing location.

The following types of stream crossing should be considered:

- **Culverts:** Appropriate to control erosion, but may cause erosion during installation/removal without appropriate BMP measures. Easily constructed and allows for heavy equipment loads.
- **Fords:** A ford is a streambed crossing alternative that involves crossing a waterbody at grade, on a hard surface maintained at the streambed bottom. Appropriate during dry weather and in arid areas in dry washes, ephemeral streams, and low-flow perennial streams. Ford crossings generally involve the placement of gravel or other non-erodible material to facilitate crossing and are appropriate for streams that would benefit from additional clean native or compatible gravel; for example, salmonid streams or rivers below reservoirs, and urban, channelized streams. Fords provide minimum sediment and erosion control in a stream channel and are most appropriate when the potential for stream channel erosion and dislodgement of sediment due to the addition of the material and traffic is low. A ford is the least expensive stream crossing, allows for maximum load limits, and offers very low maintenance. Fords may degrade water quality due to vehicle and equipment contact. Direct placement of gravel may be appropriate for short-term use. In addition, soil-confinement systems can also be used in low-flow intermittent stream crossings for ease with implantation and removal. Examples include:
 - Cellular Confinement Systems (CCS) crossings consist of three-dimensional cellular-type material placed on the streambed bottom and filled with rock or soil. CCSs are an effective option when used in conjunction with ford crossings because it is sufficient to support most construction equipment and is readily removable.
 - Articulated concrete mats (e.g., concrete blocks held together by steel cable or interlocking concrete blocks) can also be used for fording a stream. Articulated concrete mats can be used to harden the streambed for crossing. Gravel should be placed on the mats to fill in the voids between concrete blocks.
 - Gabion mattresses consisting of rock contained in rectangular, wire-mesh can also be used for constructing a hard driving surface. Gabion mattresses are strong and durable, flexible structures, and are easily constructed.
- **Bridges:** Appropriate for streams with high flow velocities, steep gradients, and where temporary restrictions in the channel are not allowed. Bridges are more expensive to design and construct, but provide the least streambed disturbance and waterway flow constriction.

What



(cont.)



Limitations:

- Installation may cause a waterway constriction, which can obstruct flood flow and cause flow backups, washouts, and/or scouring.
- **Installation may require RWQCB 401 Certification, USACOE 404 permit and approval by the California Department of Fish and Game. If numerical water quality standards are mentioned in any permits, sampling and testing may be required.**
- Installation and removal will usually disturb the waterway, and may require dewatering or temporary stream diversion.
- Soil confinement systems used for stream crossings must be constructed in accordance with the manufacturer's specifications, and inspected and maintained for structural integrity.
- Gravel use in the stream for soil-confinement system crossings will require agency approval.
- Requires other BMPs to minimize soil disturbance during installation and removal.

When

Stream crossings are installed at sites when:

- Appropriate permits have been secured for activities and for the stream crossing.
- Construction or operation and maintenance equipment or vehicles need to frequently cross a waterway.
- Alternate access routes impose significant constraints.
- Crossing perennial streams or waterways without a stream crossing causes significant erosion.

Where

Stream crossings should be installed at all designated crossings of perennial and intermittent streams and in dry channels that may be significantly eroded by construction or operation and maintenance traffic at locations where:

- Erosion potential from the installation is low.
- Site runoff is not directed towards the crossing in a manner that promotes erosion of the crossing.

How



Minimum standards and specifications for the design, construction, maintenance, and removal of the structure should be established by a California Registered Civil Engineer, and for bridges, a California Registered Structural Engineer. The design flow and stability safety factor should be based on risk evaluation of overtopping, flow backups, or washout.

Construction and Use:

- Install sediment traps immediately downstream of the crossings to capture sediment. Sediment traps may also be required to be part of the crossing permit. For CCS ford crossings, the gravel depth should be 6 to 12-inches to support construction vehicular traffic. Clean, washed, angular or rounded gravel should be used with cellular-block confinement systems.



How (cont.)

- Avoid oil or other potentially hazardous materials for surface treatment.
- Stabilize construction roadways, work area, and streambed bottom against erosion. Stream bed and bank stabilization, if necessary, may also be required to be part of the crossing permit.
- Construct during dry periods to minimize stream disturbance and reduce costs.
- Construct at or near the streambed elevation to prevent potential upstream flooding.
- Install erosion control BMPs to minimize erosion of embankment into flow lines.
- Any artificial obstruction placed within flowing water should only be built from material that will not introduce sediment or silt into the watercourse.
- Vehicles and equipment should not be driven, operated, fueled, cleaned, maintained, or stored in the wet or dry portions of a water body. Wetland vegetation, riparian vegetation, or aquatic organisms could be destroyed.
- The exterior of vehicles and equipment that will encroach on the water body should be maintained free of grease, oil, fuel, and residues.
- Drip pans should be placed under all vehicles and equipment placed over water bodies (e.g., bridges) when the equipment is planned to be idle for more than one hour.
- Disturbance or removal of vegetation should not exceed the minimum necessary to complete operations. Disturbed vegetation should be replaced with the appropriate soil stabilization measures.
- Riparian vegetation, when removed pursuant to the work provisions, should be cut off no lower than the ground level to promote rapid re-growth. Access roads and work areas built over riparian vegetation should be covered by a sufficient layer of clean river run cobble to prevent damage to the underlying soil and root structure. The cobble must be removed upon completion of project activities.

Maintenance and Inspection

- Inspect and verify that activity-based BMPs are in place prior to the commencement of associated activities. While activities associated with the BMP are under way, inspect prior to and after each storm event, daily during extended rain events during the construction and/or clean-up activity (e.g., weekly, or in compliance with the frequency specified in the project specific SWPPP, if applicable). Initiate repairs related to a storm event within 72 hours of identifying the problem or as soon as possible but prior to the next predicted storm event, per the CGP.
- Check for blockage in the channel, sediment buildup or trapped debris in culverts, blockage behind fords or under bridges.
- Check for erosion of abutments, channel scour, riprap displacement, or other signs of erosion.

NON-STORM WATER DISCHARGE CONTROLS

Stream Crossings

BMP 3-09



Maintenance and Inspection (cont.)

- Check for structural weakening of the crossings, such as cracks, and undermining of foundations and abutments.
- Remove sediment that collects behind fords, in culverts, and soil confinement systems. Removal of undesirable sediment may be required to be part of the crossing permit.
- Replace lost or displaced support aggregate from inlets and outlets of culverts and soil confinement systems.
- With proper BMPs, remove temporary stream crossings promptly when it is no longer needed.

Pictures

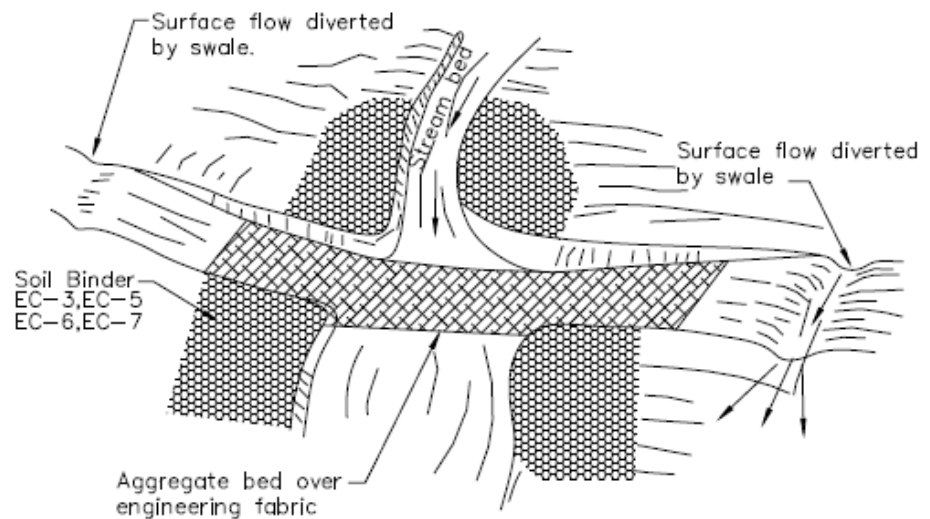

Aggregate approach
1:5 (V:H) Maximum slope on road

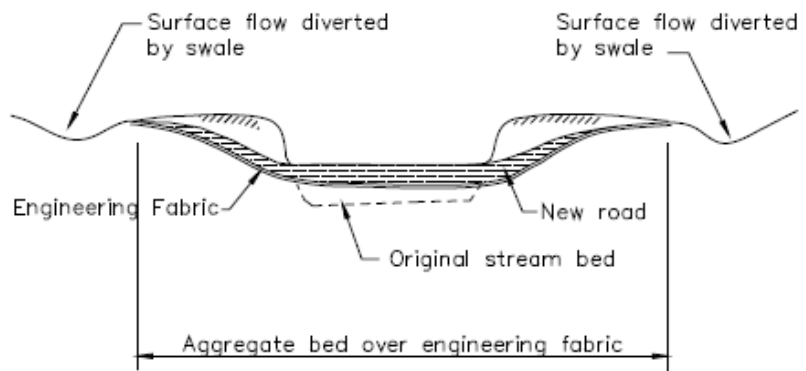

TYPICAL FORD CROSSING
NOT TO SCALE

NON-STORM WATER DISCHARGE CONTROLS

Stream Crossings

BMP 3-09



**Corresponding
CASQA
Fact Sheet**

Fact Sheet NS-4



What Clear water diversion is a system of structures and measures that intercept clear surface water runoff upstream of a construction project or operation and maintenance activity, transport it around the work area, and discharge it downstream with minimal water quality degradation. It encloses a construction area in a waterway and reduces sediment pollution from construction in, or adjacent to water. Structures commonly used as part of this system include diversion ditches, berms, dikes, slope drains, rock, gravel bags, wood, aqua barriers, cofferdams, filter fabric, or turbidity curtains, drainage or interceptor swales, pipes, or flumes.

Limitations:

- Diversion activities will usually disturb the waterway during installation/removal.
- Installation may require RWQCB 401 Certification, USACOE 404 permit and approval by California Department of Fish and Game. If numerical water quality standards are mentioned in any permits, sampling and testing may be required.
- Diversion activities may constrict the waterway, obstruct flood flows, and cause flooding or washouts. Diversion structures should not be installed without identifying potential impacts to the stream channel.
- Diversion or isolation activities are not appropriate in channels where there is insufficient stream flow to support aquatic species in the dewatered area or if they will disturb sensitive aquatic species.
- Diversion or isolation activities are inappropriate in deep water unless designed and reviewed by a California Registered Civil Engineer.
- Diversion or isolation activities should not completely dam stream flow.
- Dewatering and removal may require additional sediment control or water treatment.

When Clear water diversions should be implemented when:

- Isolating construction or operations and maintenance activities is necessary within or near a water body to protect the water body from the activity. Applicable activities may include but are not limited to: stream bank stabilization, culvert, bridge, pier, or abutment installation. They may also be used in combination with other methods, such as clear water bypasses and/or pumps.

Where

- A clear water diversion is typically implemented where appropriate permits have been secured and work must be performed in a flowing stream or water body.
- Pumped diversions are suitable for intermittent and low flow streams.
- Excavation of a temporary bypass channel, or passing the flow through a flume with a trench excavated under it, is appropriate for the diversion of streams less than 20 feet wide, with flow rates less than 100 cubic feet per second.
- Clear water diversions incorporating clean washed gravel may be appropriate for use in fish spawning streams.

**How**

In general:

- Where working areas encroach on flowing streams, barriers adequate to prevent the flow of muddy water into streams should be constructed and maintained. During construction of the barriers, stream muddying should be minimized.
- Diversion structures must be adequately designed to accommodate fluctuations in water depth or flow volume due to tides, storms, floods, etc.
- Equipment driven in a water body should be clean of petroleum residue, and water levels should be below the fuel tanks, gearboxes, and axles, unless lubricants and fuels are sealed such that water inundation will not result in pollutant discharges.
- Only excavation equipment buckets may reach out into the water body to remove or place fill. The main equipment body should not enter the water except as necessary to cross the stream to access the work site.
- Stationary equipment, such as motors or pumps located within or adjacent to a water body, should be positioned over drip pans.
- When any artificial obstruction is being constructed or maintained, sufficient water should at all times pass downstream to maintain aquatic life.
- Equipment should not park below high water marks unless allowed by permit.
- Disturbance or removal of vegetation should be minimized. Disturbed vegetation should be replaced with appropriate erosion control measures.
- Riparian vegetation, when removed pursuant to the work provisions, should be cut off no lower than the ground level to promote rapid re-growth. Access roads and work areas built over riparian vegetation should be covered by a sufficient layer of clean river run cobble to prevent damage to the underlying soil and root structure. The cobble must be removed upon completion of project activities.
- Drip pans should be placed under all vehicles and equipment placed structures over water bodies when the equipment is planned to be idle for more than one hour.
- Where possible, minimize diversion and encroachment impacts by scheduling construction during periods of low flow. Scheduling should also consider seasonal releases of water from dams, fish migration, and spawning seasons, and water demands due to irrigation.
- Construct diversion structures with materials free of potential pollutants such as soil, grease, or oil.

Several types of clear water diversions are detailed in the CASQA Handbook, each with different applications, design considerations, limitations, and inspection and maintenance requirements. These types of diversions include:

- Temporary Diversions and Encroachments
- Temporary Dry Construction Areas

How (cont')

- Filter Fabric Isolation
- Turbidity Curtain Isolation
- K-Rail River Isolation
- Stream Diversions

The CASQA Handbook should be consulted for additional information for these clear water diversions.

Maintenance and Inspection

- Inspect and verify that activity-based BMPs are in place prior to the commencement of associated activities. While activities associated with the BMP are under way, inspect weekly during the rainy season and at two week intervals in the non-rainy season to verify continued BMP implementation (e.g., or in compliance with the frequency specified in the CGP, if applicable).

Pictures



Corresponding CASQA Fact Sheet

Fact Sheet NS-5

EROSION CONTROL AND SOIL STABILIZATION

Preservation of Existing Vegetation

BMP 4-01



What Preservation of Existing Vegetation is a procedural BMP that maximizes the preservation of existing trees, shrubs, bushes, and grasses on a construction or operations and maintenance activity site.

When This BMP is applicable to utility activities when there is existing vegetation.

Where All construction and operations and maintenance activity sites where:

- There are areas on site where no activity is planned or will occur later.
- There are areas with vegetation that can be preserved to protect against soil erosion, such as on steep slopes, watercourses, and building sites in wooded areas.
- There are areas designated as ESAs, or where federal, state, or local government regulations require preservation, such as wetlands, vernal pools, marshes, etc.

How Use the following measures as applicable:

- Preserve existing vegetation whenever possible.
- Identify areas to be preserved in the immediate vicinity of the construction or activity site, and mark as appropriate before clearing and grubbing or other soil disturbance activities.
- If necessary, contact the project Field Environmental Representative for any clarification regarding areas to be preserved.
- Whenever possible, minimize disturbed areas by locating temporary roadways to avoid stands of trees and shrubs and follow existing contours to reduce cutting and filling.
- Construction materials, equipment storage and parking areas should be located outside the drip line of any tree to be retained.
- Consider the impact of grade changes to existing vegetation and the root zone.
- Remove any markings, barriers, or fencing after project is completed.
- Maintain the clearly marked limits of disturbance during construction to preserve vegetation.
- Inspect barriers regularly during construction.

**Maintenance
and
Inspection
Pictures**



Vegetation to be preserved is marked and outside the work area.

**Corresponding
CASQA
Fact Sheet**

Fact Sheet EC-2



What	<p>Temporary Soil Stabilization is a procedural BMP utilizing protective materials to cover exposed soil, where the soil exposure is caused by construction or operation and maintenance activities. Materials may include hydraulic mulch and seeding, soil binders, straw, geotextiles, plastic covers and erosion control blankets.</p> <p>Temporary soil stabilization BMPs and their associated materials include:</p> <ul style="list-style-type: none">• BMP 4-03 - Hydraulic Mulch• BMP 4-04 - Hydroseeding• BMP 4-05 - Soil Binders• BMP 4-06 - Straw Mulch• BMP 4-07 - Geotextiles, Plastic Covers and Erosion Control Blankets/Mats
When	<p>This BMP, and the situation appropriate BMPs listed above, is applicable when slopes are constructed or disturbed and/or where there are inactive soil disturbance areas that will not be worked for 14 days or more. The procedures are to be implemented after slope construction activity is complete and then prior to the onset of precipitation.</p>
Where	<ul style="list-style-type: none">• Slopes, soil stockpiles, and inactive disturbed soil areas.• Soil binders (BMP 4-05) may be applicable to areas where there is light traffic that would minimize the effectiveness of other temporary soil stabilization BMPs.
How	<ul style="list-style-type: none">• Sediment control BMPs used to break up the slope lengths, such as fiber rolls (BMP 1-03) or gravel bag berms (BMP 1-04) should be spaced in accordance with the CGP requirements (see installation for BMP 1-03 "Fiber Rolls")• Permanent erosion control shall be applied to areas deemed substantially complete during the project's defined seeding season window.• Refer to individual temporary soil stabilization BMPs for specific instructions for use (see BMP 4-03 through BMP 4-07).
Maintenance and Inspection	<ul style="list-style-type: none">• Refer to individual temporary soil stabilization BMPs listed above for maintenance and inspection requirements.

Pictures



Applying a tackifier using a trailer mounted pump and hose.



Applying soil stabilization manually in harder to reach areas.

**Corresponding
CASQA
Fact Sheet**

Fact Sheet EC-2



- What** Hydroseeding is a procedural BMP for the application of vegetation seed in a protective mixture for both soil and seed. The seed then sprouts, providing vegetation that provides additional soil erosion control (holds the soil in place and shields the soil from erosion). Hydroseeding material typically consists of a mixture of fiber, seed, fertilizer, and stabilizing emulsion.
- When**
- When temporary protection is needed until permanent vegetation protection can be established. Temporary vegetation should not be used for more than 3 to 6 months.
 - Avoid using hydroseeding during dry weather periods, unless supplemental irrigation is used.
- Where**
- Use on disturbed soil areas that must be re-disturbed following construction inactivity of 14 or more days.
 - Avoid use of hydroseeding in areas where the BMP would be incompatible with site conditions. These conditions include:
 - Slopes steeper than 1:3 vertical: horizontal. Steep slopes are difficult to protect with temporary seeding.
 - Traffic areas, where construction or other traffic would prevent seed sprouting or vegetation growth. Consider using soil binders instead (see BMP 4-05).
- How**
- Hydroseeding can be accomplished using a multiple-step (with straw mulch) or a one-step process (mixed with hydraulic mulch, hydraulic matrix, or bonded fiber matrix). When the one-step process is used to apply the mixture of fiber, seed, etc., the seed rate shall be increased to compensate for all seed not having direct contact with the soil. Confirm with your project Field Environmental Representative the appropriate seed mix to be used.
 - Prior to application roughen the slope, fill area, or area to be seeded with the furrows trending along the contours.
 - Apply straw mulch as necessary to keep seeds in place and to moderate soil moisture and temperature until the seeds germinate and grow.
 - Follow-up applications shall be made as needed to cover weak spots, and to maintain adequate soil protection.
 - Avoid over-spray onto the travel way, sidewalks, drainage channels and existing vegetation.
- Maintenance and Inspection**
- All seeded areas shall be inspected for failures and re-seeded, fertilized, and mulched within the planting season, using not less than half the original application rates. Any temporary re-vegetation effort that does not provide adequate cover must be re-vegetated.
 - After any rainfall event, maintain all slopes to prevent erosion.

Pictures



Applying hydroseed.

**Corresponding
CASQA
Fact Sheet**

Fact Sheet EC-4



What This Erosion Control and Soil Stabilization BMP is a procedural BMP for the installation of specific erosion control soil stabilization materials to control erosion from wind and water. These materials consist of:

- Geotextile blankets/mats,
- Plastic covers, and
- Natural/man-made material erosion control blankets.

Geotextiles are permeable fabrics typically made from polypropylene (plastic) or polyester that have the ability to protect the soil from erosion but are able to allow some water to reach and to drain the soil. Geotextile fabrics come in three basic forms: woven, needle punched, or heat bonded. Geotextiles also allow controlled rate and filtered drainage from a slope for slope moisture control, while providing slope reinforcement and protection.

Plastic Covers, such as Visqueen, are essentially impermeable and are used for immediate, temporary protection.

Erosion control blankets/mats are meant to protect exposed soil from wind and rain impact and reduce the speed at which water moves across the soil surface. These blankets can be made out of straw, coconut fiber, aspen fiber, jute, and polypropylene. Permeability varies according to material and material weave.

When

- Use blankets/mats when disturbed soils, especially on moderate to steep slopes, are difficult to stabilize or access. Due to wildlife concerns, consult with your project Field Environmental Representative for any restrictions on using these products on your project.

- Geotextile blanket/mats should be used when slope reinforcement may be required.
- Geotextile blankets/mats and natural fiber blankets/mats (depending on their permeability) are used when it is important to allow some water to reach the soil for seed germination or allow slope drainage for moisture control.

Where

- Blankets and mats are generally not suitable for excessively rocky sites or areas where the final vegetation will be mowed (because staples and netting can catch in mowers).

- Plastic results in 100 percent runoff, therefore, their use is limited to:
 - Covering small stockpiles.
 - Covering small graded areas for short periods, such as through an imminent storm event, until alternative measures may be installed.
 - Note the CGP discourages the use of plastic materials for cover when more sustainable alternatives can be used.

Blankets/mats should be used where there are:

- Steep slopes, generally steeper than 1:3 (vertical: horizontal).
- Slopes where the erosion hazard is high.
- Slopes and disturbed soils where mulches would need to be anchored.
- Disturbed areas where plants are slow to develop adequate protective cover.
- Channels with high flows.
- Channels intended to be vegetated.
- Slopes adjacent to water bodies or ESAs).

How For blankets or mat materials, proper site preparation is essential to ensure complete contact of the blanket or matting with the soil.



How (cont.)

- Grade and shape the area of installation.
- Remove all rocks, clods, vegetation or other obstructions so that the installed blankets or mats will have complete, direct contact with the soil.
- Prepare seedbed by loosening of topsoil.
- Seed the area before blanket installation for erosion control and vegetation. Seeding after mat installation is often specified for turf reinforcement. When seeding prior to blanket installation, all check slots and other areas disturbed during installation must be re-seeded. Where soil filling is specified, seed the matting and the entire disturbed area after installation and prior to filling the mat with soil.
- U-shaped wire staples, metal geotextile stake pins, or triangular wooden stakes can be used to anchor mats and blankets to the ground surface.
- Wire staples and metal stakes should be driven flush to the soil surface.
- All anchors should be 6 inches to 18 inches long and have sufficient ground penetration to resist pullout. Longer anchors may be required for loose soils.
- Installation on slopes - Consult the manufacturer's recommendations for installation. In general, these will be as follows:
 - Begin at the top of the slope and anchor the blanket in a 6 inch deep by 6 inch wide trench. Backfill trench and tamp earth firmly.
 - Unroll blanket down slope in the direction of water flow.
 - Overlap the edges of adjacent parallel rolls 2 inches to 3 inches and staple every 3 feet.
 - When blankets must be spliced, place blankets end over end (shingle style) with a 6 inch overlap. Staple through overlapped area, approximately 12 inches apart.
 - Lay blankets loosely and maintain direct contact with the soil. Do not stretch.
 - Staple blankets sufficiently to anchor blanket and maintain contact with the soil. Staples shall be placed down the center and staggered with the staples placed along the edges.
- Blankets and mats must be removed and disposed of prior to application of permanent soil stabilization measures.
- For plastic sheeting, it is important for the entire stockpile or exposed soil area to be covered completely, and the plastic firmly anchored with anchor objects spaced evenly along the entire perimeter so that wind, or storm water run-on, does not uncover the stockpile. Suitable anchors are gravel bags, sand bags, hay bales, or other non-polluting objects that can be safely handled.

Maintenance and Inspection

- Areas covered with temporary soil stabilization should be inspected routinely and before and after significant forecasted storm events. Any failures should be repaired immediately. Areas covered with temporary soil stabilization should be maintained to provide adequate erosion control. Temporary soil stabilization should be reapplied or replaced on exposed soils when greater than 10 percent of the previously covered area becomes exposed or exhibits visible erosion.
- If washout or breakage occurs, re-install the material after repairing the damage to the slope or channel.

Pictures



Several types of erosion control blankets.

**Corresponding
CASQA
Fact Sheet**

Fact Sheet EC-7



- What** Dust (Wind Erosion) control is a procedural BMP that consists of applying water or other dust suppressant to prevent or alleviate dust nuisance generated by construction and operations and maintenance activities.
- When**
- Dust control must be used whenever wind speed picks up dust and creates visual dust emissions. Dust control should be used at least initially on any project when exposed soil is subject to vehicle traffic and soil disturbance activities (e.g., dirt construction site, dirt access road traffic, grading, excavating, and soil stockpile generation, or soil removal from soil stockpiles).
 - Dust control must be implemented in accordance with local air quality requirements.
- Where** All construction and operations and maintenance activity sites where exposed soil is susceptible to wind erosion.
- How** Use the following measures as applicable:
- Appropriate methods of applying dust control (water, chemical dust suppressant, or soil covers and the means to apply it) should be available for construction or operation and maintenance activity sites with the potential to create dust.
 - Water applied for dust control should be applied evenly and in a manner that does not generate runoff.
 - Dust control methods should be approved by the project Field Environmental Representative. A construction permit or an agency rule may require specific control procedures.
 - Obtain prior approval to use any chemical dust suppressant from the project Field Environmental Representative. Dust suppressant chemicals must be on SDG&E's approved product list
 - Non-potable water should not be conveyed in tanks or drainpipes that will be used to convey potable water, and there should be no connection between potable and non-potable supplies. Non-potable tanks, pipes and other conveyances should be marked **"NON-POTABLE WATER - DO NOT DRINK."** Approval for use of all non-potable sources of water must be obtained from the project Field Environmental Representative.
 - If reclaimed wastewater is used for dust control, the sources and discharge must meet California Department of Health Services water reclamation criteria and RWQCB requirements. Approval for use of reclaimed wastewater must be obtained from the project Field Environmental Representative.
- Maintenance and Inspection**
- Check areas protected to ensure coverage.
 - Reapply water, chemical dust suppressants, or maintain soil covers as necessary to maintain their effectiveness.





Pictures



Water being applied for dust control.

**Corresponding
CASQA
Fact Sheet**

Fact Sheet WE-1



- What** A diversion berm is a temporary berm of compacted soil used to direct runoff water to a desired location. A drainage swale is a shaped and sloped soil depression used to convey runoff to a desired location. Diversion berms and drainage swales divert off site runoff around the construction or operation and maintenance site, divert runoff from flowing onto stabilized areas and disturbed areas, and direct runoff into sediment basins or traps. A diversion berm or swale itself does not control erosion or remove or trap sediment from runoff.
- Limitations:
- Diversion berms may create disturbed areas and become construction equipment barriers.
 - Diversion berms must be stabilized immediately, adding cost and maintenance.
 - Diverted storm water may cause downstream flood damage.
 - Berms should not be constructed of easily eroded soils.
 - Regrading the site to remove the berm may add cost.
 - Other soil stabilization and sediment controls such as check dams, plastics, and blankets may be needed to prevent erosion in newly graded berms and swales.
 - Sediment accumulation, scour depression, and/or persistent non-storm water discharges can result in standing water suitable for mosquito production.
- When** Diversion berms and drainage swales are suitable for use, individually or together, where runoff needs to be diverted from one area to another. These BMPs may be used:
- To direct runoff away from disturbed areas or at the top of slopes.
 - To convey surface runoff down sloping land.
 - To divert runoff towards a stabilized watercourse, drainage pipe, or channel.
 - To intercept runoff from paved surfaces.
 - To divert sediment laden runoff into sediment basins or traps.
- Where** Diversion berms and drainage swales should be considered:
- At the top of slopes to divert run-on from adjacent or undisturbed slopes.
 - At bottom and mid-slopes to intercept sheet flow and convey concentrated flows.
 - Below steep grades where runoff begins to concentrate.
 - Along roadways and facility improvements subject to flood drainage.
 - Berms should not be used for drainage areas greater than 10 acres or along slopes greater than 10 percent. For larger drainage areas, more permanent drainage structures should be built in accordance with local requirements.
 - Drainage areas more than 5 acres should not drain to a temporary drainage swale. For larger drainage areas, use berms, or more permanent drainage structures should be built in accordance with local requirements.
- How** Berms and swales should not adversely affect adjacent properties and must conform to local floodplain management regulations. Obtain written



How (cont.)

authorization from property owner to divert runoff onto another property.

- Care must be applied to correctly size and locate berms and drainage swales.
- Conveyances and outlets should be stabilized.
- Size to control flow velocity based on evaluation of the erosion risk, soil types, overtopping, flow backups, washout, and site drainage flow patterns.
- Install permanent berms and swales early in the construction process.

Diversion Berms:

- Compact all berms and provide positive drainage to an outlet.
- All berms should have 1:2 (vertical: horizontal) or flatter side slopes, and minimum 18-inch height, and minimum 24-inch top width. Wide top widths and flat slopes are usually needed for construction traffic crossings.
- Runoff should be conveyed to a sediment trapping device when the berm channel or the drainage area above the berm are not adequately stabilized.
- Temporary stabilization may be achieved using seed and mulching for slopes less than 5 percent and either riprap or sod for slopes greater than 5 percent. Stabilization should be completed immediately after installation/placement.
- If riprap is used to stabilize the channel formed along the toe of the berm, the following typical specifications apply:

Channel Grade	Riprap Stabilization
0.5 - 1%	4 inch Rock
1.1 - 2.0%	6 inch Rock
2.1 - 4.0%	8 inch Rock
4.1 - 5.0%	8 to 12 inch Riprap

- The riprap, recycled concrete, etc. should be pressed into the soil with construction equipment.
- Filter fabric may be used to cover berms in use for long periods.
- Construction activity on the earthen berms should be kept to a minimum.

Drainage Swales:

Standard engineering design criteria for small open channel and closed conveyance systems should be used. Unless local drainage design criteria state otherwise, drainage swales should be designed as follows:

- Place drainage swales above or below, not on, a cut or fill slope.
- Swale bottom width should be at least 2 feet, and the depth of the swale should be at least 18 inches. The swale side slopes should be 1:2 (vertical: horizontal) or flatter.
- Drainage swales should be at a grade of at least 1 percent, but not more than 15 percent.
- The swale must not be overtopped by the peak discharge from a 10-year storm, irrespective of the design criteria above.



How (cont.)

- Remove all vegetation and other objectionable materials and compact the fill material along the swale path.
- Stabilize all swales immediately after installation/placement. Seed and mulch swales with slopes of less than 5 percent and use riprap or sod for swales with slopes between 5 and 15 percent. For temporary swales, geotextiles and mats may provide immediate stabilization.
- Irrigation may be required to establish sufficient vegetation to prevent erosion.
- Do not operate vehicles across a swale unless a stabilized crossing is provided.
- Permanent drainage facilities must be designed by a California Registered Civil Engineer.
- At a minimum, the drainage swale should conform to predevelopment drainage patterns and capacities.
- Construct the drainage swale with a positive grade to a stabilized outlet.
- Provide erosion protection or energy dissipation measures if the flow out of the drainage swale can reach erosive velocity.

Maintenance and Inspection

- Inspect berms and drainage swales dams prior to, daily during, and after each storm event, and routinely throughout the construction activity (e.g., weekly, or in compliance with the frequency specified in the CGP, if applicable).
- Inspect BMPs subject to non-storm water discharges daily while the discharges occur.
- Inspect ditches and berms for washouts and erosion. Repair riprap, damaged linings, or soil stabilizers, and linings as needed.
- Inspect channel linings, embankments, and beds of swales and berms for erosion and accumulation of debris and sediment. Remove accumulated debris and sediment as needed. Removed sediment shall be incorporated in the project at appropriate locations or disposed of in accordance with federal, state and local requirements.
- Temporary conveyances should be completely removed as soon as the surrounding drainage area has stabilized or at the completion of construction.

Pictures

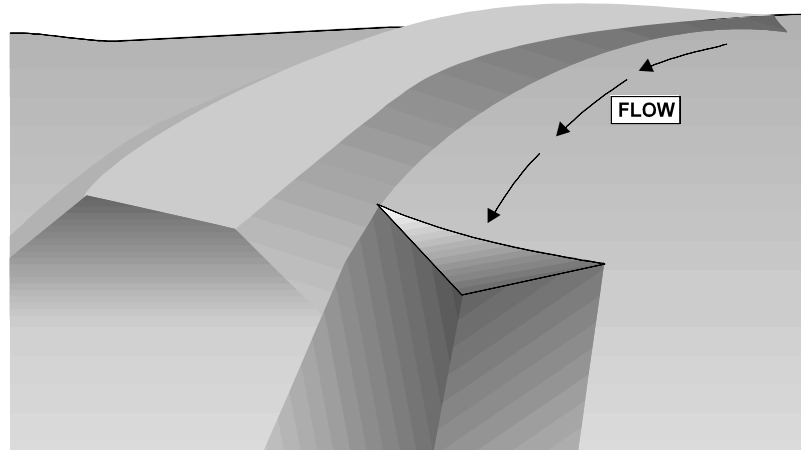

EROSION CONTROL AND SOIL STABILIZATION

Diversion Berms and Drainage Swales



**Corresponding
CASQA
Fact Sheet**

Fact Sheet EC-9



- What** Velocity dissipation devices are composed of rock, riprap, grouted riprap or concrete rubble, placed at the outlet of a pipe, channel, or waterbar to prevent scour and erosion caused by concentrated high velocity flows. There are many types of dissipation devices.
- Limitations:
- Large storms or high flows can wash away the outlet protection and leave the area susceptible to erosion.
 - Sediment captured by the outlet protection may be difficult to remove without removing the protection.
 - Outlet protection may negatively impact the channel habitat.
 - Grouted riprap may break up in areas of freeze and thaw.
 - With inadequate drainage, water may build up behind and break grouted riprap.
 - Sediment accumulation, scour depression, and/or persistent non-storm water discharges can result in standing water suitable for mosquito production.
- When** Velocity dissipation devices are suitable when discharge velocities and energies at the outlets of culverts, conduits, waterbars, or channels are sufficient to erode the next downstream reach.
- Where** Velocity dissipation devices should be considered:
- At outlets of pipes, drains, culverts, slope drains, diversion ditches, swales, conduits, channels, waterbars, etc.
 - At outlets located at the bottom of mild to steep slopes.
 - At discharge outlets that carry continuous water flow.
 - At outlets subject to short, intense water flows, such as flash floods.
 - At points where lined conveyances discharge to unlined conveyances.
- How** Depth of flow, roughness, gradient, side slopes, discharge rate, and velocity should be considered in the outlet design. Compliance to local and state regulations should be considered, particularly while working in environmentally sensitive streambeds.
- Determine the apron length and rock size gradation using the discharge pipe diameter and estimated discharge rate table below. Select the longest apron length and largest rock size suggested by the pipe size and discharge rate. Recommendations for rock size and length of outlet protection mat should be considered minimums. Use sound, durable, and angular rock.
 - Where flows are conveyed in open channels such as ditches or swales, use the estimated discharge rate for selecting the apron length and rock size. Flows should be the same as the culvert or channel design flow but never less than the peak 5 year flow for temporary structures planned for one rainy season, or the 10 year peak flow for temporary structures planned for two or three rainy seasons.
 - Install filter fabric, riprap, grouted riprap, or concrete apron at selected outlet. Install filter fabric or well-graded filter layer beneath the riprap apron. Riprap aprons are best suited for temporary use during construction. Grouted or wired riprap can minimize maintenance.
 - Rock outlet protection is usually less expensive and easier to install than concrete aprons or energy dissipaters, and serves to trap sediment and reduce flow velocities.



**How
(cont.)**

- Carefully place riprap to avoid damaging the underlying filter fabric.
 - Rock 4 to 6-inches may be carefully dumped onto the filter fabric from a maximum height of 12 inches.
 - 8- to 12-inch rock must be hand placed onto filter fabric, or the filter fabric may be covered with 4 inches of gravel, and the rock may be dumped from a maximum height of 16 inches.
 - Rock greater than 12 inches shall only be dumped onto filter fabric protected with a layer of gravel with a thickness equal to one-half the D_{50} rock size, with the dump height limited to twice the gravel protection layer thickness.
- Align apron with receiving stream and keep straight throughout its length. If a curve is needed to fit site conditions, place it in the upper section of the apron.
- Outlets on slopes steeper than 10 percent should have additional protection.

Pipe Diameter (in)	Discharge (ft ³ /s)	Apron Length (ft)	Min. Riprap D_{50} Diameter (in)
12	5	10	4
	10	13	6
18	10	10	8
	20	16	12
	30	23	16
	40	26	8
24	30	16	8
	40	26	12
	50	26	16
	60	30	8

**Maintenance
and
Inspection**

- Inspect velocity dissipation devices prior to and after each rain event, and daily during extended rain events throughout the construction activity (e.g., weekly, or in compliance with the frequency specified in the project specific SWPPP, if applicable). Initiate repairs related to a storm event within 72 hours of identifying the problem or as soon as possible but prior to the next predicted storm event, per the CGP.
- Inspect BMPs subject to non-storm water discharges daily while the discharges occur. Minimize standing water by removing sediment blockages and filling depressions.
- Inspect apron for displacement of the riprap and damage to the underlying fabric. Repair fabric and replace riprap that has washed away. If riprap continues to wash away, consider using larger material.
- Inspect for scour beneath the riprap and around the outlet. Repair damage to slopes or underlying filter fabric immediately.
- Temporary devices should be completely removed as soon as the surrounding drainage area has been stabilized or at the completion of construction.

EROSION CONTROL AND SOIL STABILIZATION

Velocity Dissipation Devices



Pictures

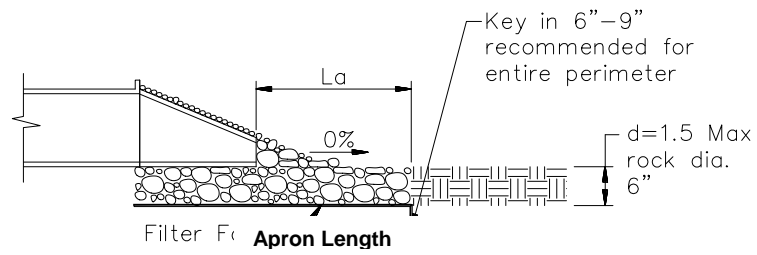
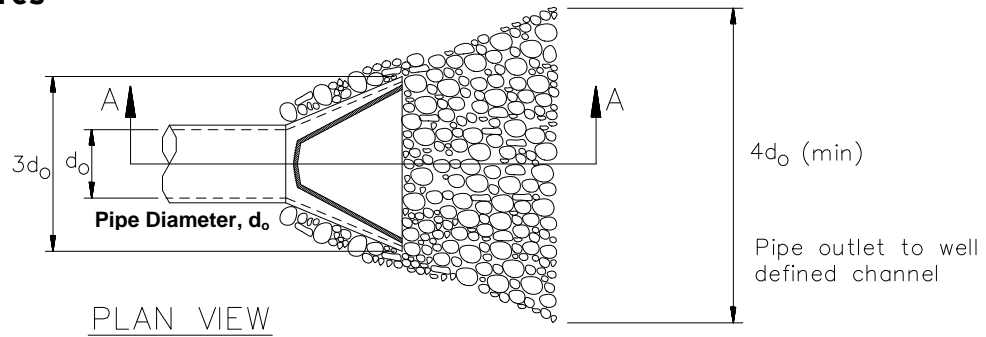

Corresponding
CASQA
Fact Sheet

Fact Sheet EC-10



What A slope drain is a pipe used to intercept and direct surface runoff or groundwater into a stabilized watercourse, trapping device, or stabilized area. Slope drains are typically used with diversion berms and drainage ditches to intercept and direct surface flow away from slope areas to protect cut or fill slopes. Slope drains prevent storm water from flowing directly down the slope by confining the runoff into an enclosed pipe or channel. The slope drain may be installed as a rigid pipe, such as corrugated metal, a flexible conduit, or a lined terrace drain with a top of a slope inlet and a bottom of a slope outlet.

Limitations:

- Slope drain sizing, installation, and maintenance is critical to minimize the potential for failure. Severe erosion may result when slope drains fail by overtopping, pipe separation, or other signs of erosion.
- Dissipation of high flow velocities at the pipe outlet is required to avoid erosion.
- Sediment accumulation, scour depression, and/or persistent non-storm water discharges can result in standing water suitable for mosquito production.

When Slope drains are suitable when:

- Concentrated runoff flow must be conveyed down a slope.
- Drainage is needed for top of slope diversion dikes or swales.
- Drainage is needed for top of cut and fill slopes where water can accumulate.
- Emergency spillway is required for a sediment basin.

Where Slope drains should be considered where:

- The drainage area is less than 10 acres per slope drain. For larger areas, use a rock-lined channel, or subdivide into areas of 10 acres or less, with each area is treated as a separate drainage.
- Drainage areas exceeding 10 acres must be designed by a California Registered Civil Engineer and approved by the agency that issued the grading permit.

How

- Permanent structures included in the project plans can often serve as construction BMPs if implemented early. However, the permanent structure must meet or exceed the criteria for the temporary structure.
- Slope drains and inlets must be securely attached to the slope and must be adequately sized to carry the capacity of the design storm and associated forces.
- Outlets must be stabilized with riprap, concrete, or other type of energy dissipater, or directed into a stable sediment trap or basin.
- Debris racks are recommended at the inlet. Debris racks are barriers used to collect debris that is too large to pass through the inlet. Debris racks located several feet upstream of the inlet can usually be larger than racks at the inlet, and thus provide enhanced debris protection and less plugging.



How (cont.)

- Safety racks are also recommended at the inlet and outlet of pipes to prevent a human body or animal from washing into the pipe and/or becoming trapped.
- Size to convey at least the peak flow of a 10-year storm. The design storm is conservative due to the potential impact of system failures. The pipe size may be computed using the Rational Method or a method established by a local municipality. Higher flows must be safely stored or routed to prevent any offsite concentration of flow or erosion. Maximum slope generally limited to 1:2 (vertical: horizontal) as energy dissipation below steeper slopes is difficult.
- Direct surface runoff to slope drains with interceptor dikes. Top of interceptor dikes should be 12 inches higher than the top of the slope drain.
- Slope drains can be placed on or buried beneath the slope surface.
- As a guide, temporary slope drains should not be sized smaller than shown in the following table:

Minimum Pipe Diameter (inches)	Maximum Drainage Area (Acres)
12	1.0
18	3.0
21	5.0
24	7.0
30	10.0

- Recommended materials include metal, plastic, or concrete pipe, either corrugated or smooth wall. The following types of slope drains are common:
 - Rigid Pipe: Also known as a pipe drop, the pipe usually consists of corrugated metal pipe or rigid plastic pipe. The pipe is placed on undisturbed or compacted soil and secured to the slope surface or buried in a trench. Concrete thrust blocks must be used when warranted by the calculated thrust forces. Collars should be properly installed and secured with straps or watertight collars.
 - Flexible Pipe: The pipe consists of a flexible tube of heavy duty plastic, rubber, or composite material. The tube material is securely anchored to the slope surface. The tube should be securely fastened to the metal inlet and outlet conduit sections with metal straps or watertight collars.
 - Section Downdrains: The section downdrain consists of a pre-fabricated, section conduit of half round or third round material, and performs similar to a flume or chute. The pipe must be placed on undisturbed or compacted soil and secured into the slope.
 - Concrete-Lined Terrace Drain: This concrete channel drains water from a slope terrace to the next level. These drains are typically specified as permanent structures and should be designed according to local criteria. If installed early, they can be construction slope drains.

How



- (cont.)** When installing slope drains:
- Install perpendicular to slope contours.
 - Compact soil around and under entrance, outlet, and along length of pipe.
 - Securely anchor and stabilize pipe appurtenances into soil.
 - Check to ensure that pipe connections are watertight.
 - Protect areas around inlet with filter fabric. A flared end section installed at the inlet will improve flow into the slope drain and prevent erosion at the pipe entrance. Use a flared section with a 6-inch minimum toe plate to help prevent undercutting. The flared section should slope towards the pipe inlet.
 - Protect outlet with riprap or other energy dissipation device. Protect outlet of slope drains using a flared end section when outlet discharges to a flexible energy dissipation device.
- Maintenance and Inspection**
- Inspect slope drains prior to and after each storm event, and daily during extended rain events throughout the construction activity (e.g., weekly, or in compliance with the frequency specified in the project specific SWPPP, if applicable). Initiate repairs related to a storm event within 72 hours of identifying the problem or as soon as possible but prior to the next predicted storm event, per the CGP.
 - Inspect BMPs subject to non-storm water discharges daily while the discharges occur. Minimize standing water by removing sediment blockages and filling depressions.
 - Inspect outlet for erosion and downstream scour. If eroded, repair damage and install additional energy dissipation measures. If downstream scour is occurring, it may be necessary to reduce flows being discharged into the channel unless other preventative measures are implemented.
 - Insert inlet for clogging or undercutting. Remove debris from inlet to maintain flows. Repair undercutting at inlet, and if needed, install flared section or riprap around the inlet to prevent further undercutting.
 - Inspect pipes for leakage. Repair leaks and restore damaged slopes.
 - Inspect slope drainage for accumulations of debris and sediment. Remove sediment from entrances and outlets as required. Flush drains as necessary; capture and settle out sediment from discharge.
 - Ensure water is not ponding onto inappropriate areas (e.g. active traffic lanes, material storage areas, etc.).
 - Pipe anchors must be checked to ensure that the pipe remains anchored to the slope. Install additional anchors if pipe movement is detected.

Pictures

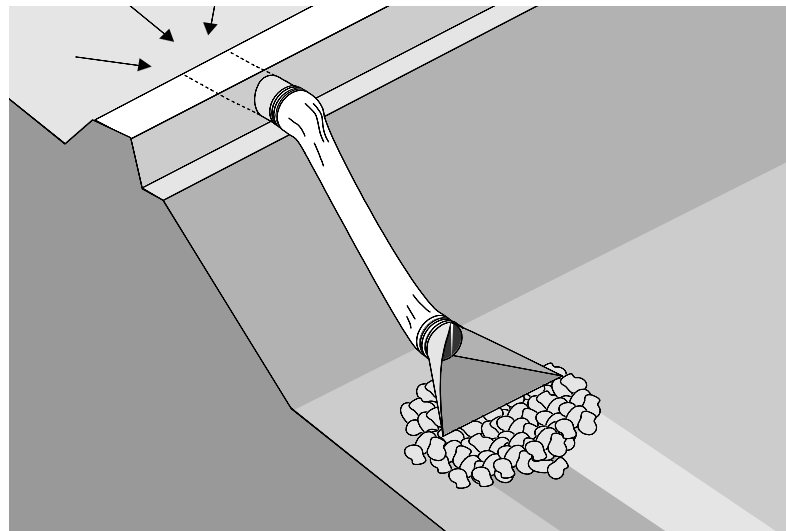

**Corresponding
CASQA
Fact Sheet**

Fact Sheet EC-11



What Streambank stabilization includes measures to reduce the discharge of sediment from streambanks with exposed or disturbed soil, or unstable banks. Streambank stabilization measures include preservation of existing vegetation, hydraulic mulch, hydroseeding, soil binders, straw mulch, geotextiles and mats, berms, and drainage swales, velocity dissipation devices, and slope drains. Streambank sediment controls include silt fences, fiber rolls, gravel bag berms, rock filters, and K-rail barriers, and padding. Each of these measures have different applications, limitations, and maintenance requirements for use as streambank stabilization.

Stream channels, streambanks, and associated riparian areas are dynamic and sensitive ecosystems that respond to changes in land use. Streams on the 303(d) list and listed for sediment may require numerous measures to prevent any increases in sediment load to the stream.

General streambank stabilization limitations:



- **Specific permit requirements or mitigation measures such as RWQCB 401 Certification, U.S. Army Corps of Engineers 404 permit and approval by the California Department of Fish and Game supersede the guidance in this BMP.**
- If numerical water quality standards are mentioned in any of these and other related permits, testing and sampling may be required. Soil disturbance activities in watersheds having streams listed as 303(d) impaired for sediment, silt, or turbidity, may require sampling to verify that there is no net increase in sediment load.

When When construction or operations and maintenance activities occur within stream channels and associated riparian areas.

Where Streambank stabilization procedures apply to all construction projects and operations and maintenance activities that disturb or occur within stream channels and their associated riparian areas.

How Planning should account for: scheduling; avoidance of wet in-stream construction; minimizing disturbance and construction time period; selecting crossing location; and selecting equipment.



- **Construction and operation and maintenance activities should be scheduled according to the relative sensitivity of the environmental concerns and will be different when working near perennial streams vs. ephemeral streams.**
- Minimize disturbance by using pre-disturbed areas, selecting the narrowest crossing location, limiting vehicle crossing trips, and minimizing the number and size of work areas. Plan work areas at least 50 feet from the stream channel.
- Avoid steep and unstable banks, highly erodible or saturated soils, or highly fractured rock.
- Select a project or work site that minimizes disturbance to aquatic species or habitat.
- Select equipment that reduces the amount of pressure exerted on the ground surface (less than 5 or 6 pounds per square inch where possible).



Maintenance and Inspection

- Inspect streambank stabilization BMPS prior to and after each storm event, and daily during extended rain events throughout the construction activity (e.g., weekly, or in compliance with the frequency specified in the project specific SWPPP, if applicable). Initiate repairs related to a storm event within 72 hours of identifying the problem or as soon as possible but prior to the next predicted storm event, per the CGP.
- Inspect BMPs subject to non-storm water discharges daily while the discharges occur.
- Inspect and repair equipment (for damaged hoses, fittings, and gaskets, etc.).

Pictures



Cobble or gravel armor used for streambank stabilization.

Corresponding CASQA Fact Sheet

Fact Sheet EC-12



What Soil preparation/roughening involves assessment and preparation of surface soils for BMP installation. This includes soil testing (for seed base, soil characteristics, or nutrients), or roughening surface soils by mechanical methods (including sheepsfoot rolling, track walking, scarifying, stair stepping, and imprinting) to prepare soils for additional BMPs or to break up sheet flow. Soil preparation can also involve tilling topsoil to prepare a seed bed and/or incorporation of soil amendments to enhance vegetative establishment. Various roughening techniques on slopes can result in a significant erosion reduction as compared to smooth slopes.

Limitations:

- Preparation and roughening must take place prior to installing other erosion controls (such as hydraulically applied stabilizers) or sediment controls (such as fiber rolls) on slope faces.
- In cases where slope preparation is minimal, erosion control/revegetation BMPs that do not require extensive soil preparation (such as hydraulic mulching and seeding applications) should be employed.
- Consideration should be given to the type of erosion control BMP that follows surface preparation, as some BMPs are not designed to be installed over various types of tillage/roughening.

When

- Soil preparation is most effective when used in combination with erosion controls. Soil preparation (i.e. tilling, raking, and amendment) is essential to proper vegetative establishment, and suitable in combination with any soil stabilization method, including rolled erosion control products (RECPs) or sod.
- Soil roughening is suitable for use as a complementary process to soil preparation for controlling erosion, and is not intended to be used as a stand-alone BMP. Soil roughening should be used with perimeter controls, additional erosion control measures, grade breaks, and vegetative establishment for maximum effectiveness. Soil roughening is referred to as track walking (sometimes called imprinting) a slope, where treads from heavy equipment run parallel to the slope contours and create terraces. Roughening is intended to only affect surface soils and should not compromise slope stability or overall compaction.

Where Soil preparation should be considered:

- Where vegetation is desired.

Soil roughening should be considered:

- Along any disturbed slopes, including temporary stockpiles, sediment basins, or compacted soil diversion berms and swales.
- Roughening should be used in combination with hydraulically applied stabilization methods, compost blankets, or straw mulch; but should not be used in combination with RECPs or sod because roughening is intended to leave terraces on the slope.

How Minimal materials are required unless amendments and/or seed are added to the soil. Most soil roughening/preparation can be done with standard construction equipment.



How (cont.)

Soil Preparation

- Where appropriate, soil should be prepared to receive the seed by disking or scarifying the surface to eliminate crust, improve air and water infiltration and create a more favorable environment for germination and growth.
- Based on soil testing, apply additional soil amendments (e.g. fertilizers, additional seed) to the soil to help with germination.

Cut Slope Roughening

- Stair-step grade or groove the cut slopes steeper than 1:3 (vertical: horizontal).
- Use stair-step grading on any erodible material soft enough to be ripped with a bulldozer. Slopes consisting of soft rock with some subsoil are well suited to stair-step grading.
- Make the vertical cut distance less than the horizontal distance, and slightly slope the horizontal position of the "step" in toward the vertical wall.
- Do not make individual vertical cuts more than 2 feet or 3 feet high in soft or rock materials, respectively.
- Groove the slope using machinery to create a series of ridges and depressions that run across the slope on the contour.

Fill Slope Roughening

- Place on fill slopes with inclinations steeper than 1:3 (vertical: horizontal) in lifts not to exceed 8 inches, and ensure that each lift is properly compacted.
- Ensure that the slope face consists of loose, uncompacted fill 4 to 6 inches deep.
- Use grooving or tracking to roughen the face of slopes, if necessary.
- Do not blade or scrape the final slope face.

Roughening for Slopes to be Mowed

- Slopes which require mowing should be flatter than 1:3 (vertical: horizontal).
- Roughen these areas to shallow grooves by track walking, scarifying, sheepsfoot rolling, or imprinting. Excessive roughness is undesirable when mowing is planned.
- Space grooves less than 10 inches apart, and not less than 1 inch deep, and perpendicular to the direction of runoff (parallel to the slope contours).

Roughening with Tracked Machinery

- Limit roughening with tracked machinery to soils with a sandy textural component to avoid undue compaction of the soil surface.
- Operate tracked machinery up and down the slope to leave horizontal depressions in the soil. Do not back-blade during the final grading operation.



**How
(cont.)
Maintenance
and
Inspection**

- Seed and mulch roughened areas as soon as possible to obtain optimum seed germination and growth.
- Inspect BMPs prior to and after each storm event, and daily during extended rain events throughout the construction activity (e.g., weekly, or in compliance with the frequency specified in the project specific SWPPP, if applicable). Initiate repairs related to a storm event within 72 hours of identifying the problem or as soon as possible but prior to the next predicted storm event, per the CGP.
- Check the seeded slopes for signs of erosion such as rills and gullies. Fill these areas slightly above original grade, then reseed and mulch as soon as possible.

Pictures



Sheepsfoot used for soil preparation

**Corresponding
CASQA
Fact Sheet**

Fact Sheet EC-15

CONSTRUCTION BMPs

[City of San Diego Storm Water Standards Manual]

Required Best Management Practices

BMPs collectively refer to a variety of pollution prevention controls implemented throughout the project site at various times during the project. BMPs discussed herein are specifically aimed to control pollution in storm water runoff during the construction phase of the project. The major construction BMP categories as identified in the MS4 Permit are:

1. Project Planning;
2. Good Site Management “Housekeeping”, including Waste Management;
3. Non Storm Water Management;
4. Erosion Control;
5. Sediment Control;
6. Run-on and Run-off Control; and
7. Active/Passive Sediment Treatment Systems, where applicable.

BMP implementation must be seasonally appropriate and must plan for year round rain events, including those that may occur during the dry season (May 1 to September 30).

In order to meet the requirements of the permits and ordinances mentioned in Chapter 3, BMPs must be selected, installed, and maintained properly throughout the duration of construction projects. Similar to OSHA Safety requirements, BMPs must be discussed with all project contractors, subcontractors, and any party involved, because education is essential to good BMP implementation and maintenance and overall site compliance. Examples of common BMPs are provided in Tables 5–1 through 5–7; refer to the CASQA Construction BMP Online Handbook and Caltrans Construction Site BMP Fact Sheets for additional BMPs.

Table 5-1. Project Planning

Type	Description
Scheduling	<ol style="list-style-type: none"> 1. Sequencing construction activities to reduce the amount of exposed soil during periods of higher precipitation probability. 2. All projects should consider scheduling activities to minimize the amount of disturbed area during periods of higher precipitation probability. 3. Phasing can be used to maintain stabilized areas (vegetation or impervious cover) as much as possible during construction. 4. Disturbed areas should be stabilized as soon as practical. 5. Attempt to schedule grading outside of periods of higher precipitation probability.
Reference	CASQA EC-1, EC-2 Caltrans SS-01

Chapter 5: Required Best Management Practices

Table 5-2. Good Site Management “House Keeping”

Type	Description
Material Delivery, Storage, and Use	<ol style="list-style-type: none"> 1. Preventing and containing pollutant discharges from materials that are delivered, stored, and used on-site. 2. Materials of concern include: petroleum products, asphalt, concrete, paints, solvents, soil stabilizers and binders, pesticides, herbicides, fertilizers, detergents, and other hazardous chemicals. Minimize the quantities of materials of concern. 3. Material delivery, storage, and use management should occur at every location of a construction project where materials of concern are delivered, stored, or used. 4. All material delivery and storage should occur in an area designated for the activity and at least 50 feet away from downstream storm drain facilities. 5. Store and label all hazardous materials and hazardous wastes (such as pesticides, paints, thinners, solvents, fuel, oil, and antifreeze) in water tight containers and in accordance with city, county, state and federal regulations in an enclosed area with secondary containment and cover them at the end of every work day or during wet weather or when rain is forecast. Erodible landscape material should be on pallets. 6. Keep absorbent spill cleanup materials available; dispose of used materials properly. 7. Train employees and subcontractors on proper spill prevention, control, and cleanup procedures. 8. Avoid over-application of soil binders, pesticides, herbicides, and fertilizers.
Reference	CASQA WM-1, WM-2, WM-4 Caltrans WM-01, WM-02
Picture	

Type	Description
Stockpile Management	<ol style="list-style-type: none"> 1. Covering or stabilizing stockpiles and providing sediment controls around the perimeter of stockpiles. 2. Stockpile management should occur at every required stockpile within a construction project year-round. 3. Required stockpiles include those of soil, sand, PCC or AC rubble, cold mix asphalt, aggregate base or sub base, treated wood, and landscaping materials. 4. Stockpile management is effective against storm water and wind erosion. 5. All stockpiles can be covered with plastic or similar material. Raw materials such as cold mix treated wood should also be placed on top of plastic. 6. Alternatively, soil stockpiles may be protected with an erosion control (stabilization) practice. 7. Application of any erodible landscape material within 2 days before a forecast rain event or during wet weather must be discontinued. 8. Typical sediment controls placed around the perimeter of stockpiles are straw wattles (fiber rolls), silt fence, and gravel bags. Inspect gravel bag barriers for sediment accumulations and remove sediments when accumulation reaches one-third the barrier height. 9. All stockpiles should be located away from concentrated flows of storm water and placed at least 50 feet away from downstream storm drain facilities. 10. Remove any temporary BMP from the site when no longer needed. 11. When approved by the Resident Engineer, stockpile material removed from roadways shall be kept away from gutters, drain inlets, drainage ditches, and watercourses. 12. Prior to the onset of precipitation, stockpiles of “cold mix” shall be placed on and covered with plastic or comparable; stockpiles of Portland cement concrete rubble, asphalt concrete, asphalt concrete rubble, aggregate base, or aggregate sub-base shall be either covered and protected with a temporary perimeter sediment barrier; soil stockpiles shall be either covered and protected with a temporary perimeter sediment barrier.
Reference	CASQA WM-3, SE-1, SE-5, SE-6, SE-8 Caltrans WM-03
Picture	

Chapter 5: Required Best Management Practices

Type	Description
Solid Waste Management	<ol style="list-style-type: none"> 1. Containing and disposing of debris and non-hazardous waste to prevent discharge to the storm drain system. 2. Solid waste management and materials pollution control should occur throughout every construction project for non-hazardous construction waste and scraps, trash from employees or subcontractors, and waste generated from demolition. Waste should be collected, contained and covered in designated areas and littering shall be prohibited. Prior to any rain event and at the end of each day, containers shall be covered and secured. 3. Solid wastes include but are not limited to: <ol style="list-style-type: none"> i. Construction wastes including brick, mortar, timber, steel and metal scraps, pipe and electrical cuttings, non-hazardous equipment parts, Styrofoam and other materials used to transport and package construction materials. ii. Landscaping wastes, including vegetative material, plant containers, and packaging materials. iii. Litter, including food containers, beverage cans, coffee cups, paper bags, plastic wrappers, and smoking materials, including litter generated by the public. Avoid using waste containers that do not have lids or are not watertight. Collect and dispose of loose trash and waste daily. Check waste disposal containers frequently for leaks and to make sure they are not overfilled. Litter and debris removal from drainage grates, trash areas and ditches shall be performed weekly to prevent clogging of storm drainage systems. Never hose down a dumpster on the construction site. Toxic liquid wastes (used oils, solvents, and paints) and chemicals (acids, pesticides, additives, curing compounds) shall not be disposed of in dumpsters as well. Berm and cover waste containers or other construction material when rain is forecast or if not actively being used within 14 days. 4. Solid waste storage areas shall be located at least 50' from drainage facilities and watercourses and shall not be located in areas prone to flooding or ponding. 5. For saw cutting & Asphalt/Concrete Removal waste; Shovel, absorb, or vacuum saw-cut slurry and dispose of all waste as soon as you are finished in one location. Residue from grinding operations shall be picked up by means of a vacuum attachment to the grinding machine, shall not be allowed to flow across the pavement, and shall not be left on the surface of the pavement. Water and concrete slurry from saw cutting activities in the gutter are allowable as long as: <ol style="list-style-type: none"> i. Inlet protection is installed and check dams are in place to slow the flow; and ii. Slurry water is removed from the street and gutter promptly; and iii. Slurry water does not enter the inlet. 6. Paint & Paint Removal is a prohibited discharge and shall be cleaned and disposed of in a proper container. Dispose of residue and unusable thinner/solvents as hazardous waste. Never pour paint down a drain.
Reference	CASQA WM-5; Caltrans WM-05
Picture	

Chapter 5: Required Best Management Practices

Type	Description
Vehicle and Equipment Pollution Prevention	<ol style="list-style-type: none"> 1. Preventing, containing, and disposing of pollutants from cleaning, fueling, and maintaining vehicles and equipment. 2. Vehicle and equipment pollution prevention should occur at every construction project that cleans, fuels, or maintains vehicles or equipment. 3. All cleaning, fueling, and maintenance performed on the site should occur in an area designated for the activity and at least 50 feet away from downstream storm drain facilities. 4. Avoid “topping-off” of fuel tanks. Keep absorbent spill cleanup materials available; dispose of used materials properly. 5. Train employees and subcontractors proper spill prevention, control, and cleanup procedures. 6. Use drip pans or a secondary containment area for fueling and maintenance. 7. Also, the use of gravel bags as temporary linear barrier can be installed along the perimeter of vehicle and equipment fueling and maintenance areas or chemical storage areas. 8. Do not clean vehicle or equipment onsite using soaps, solvents, degreasers, steam cleaning equipment, etc. 9. Inspect for equipment leaks daily. 10. Prevent equipment/vehicle leakage from entering storm drain system.
Reference	CASQA NS-8, NS-9, NS-10 Caltrans NS-08, NS-09, NS-10
Picture	

Chapter 5: Required Best Management Practices

Type	Description
Spill Prevention and Control	<ol style="list-style-type: none"> 1. Preventing, controlling, and cleaning up spills to reduce pollutant discharges from construction activities. 2. Spill prevention and control should occur at every construction project that uses petroleum products, asphalt, concrete, paints, solvents, soil stabilizers and binders, pesticides, herbicides, fertilizers, detergents, fuels, lubricants, or other products that could harm the environment. 3. Check waste disposal containers frequently for leaks and to make sure they are not overfilled. 4. Train employees and subcontractors proper spill prevention, control, and cleanup procedures. 5. Do not bury or wash spills away with water. 6. Spills shall be covered and protected from storm water run-on during rainfall. If the spill occurs during rain, cover the spill with tarps or other material to prevent contaminating runoff. 7. Minor water spillage or water overflow shall be contained and shall not be allowed to discharge into watercourses or drainage facilities. 8. Keep absorbent spill cleanup materials available; dispose of used materials properly. 9. If the spill occurs in dirt areas, immediately contain the spill by constructing an earthen dike. Dig up and properly dispose of contaminated soil. 10. Report significant spills immediately. You are required by law to report all significant releases of hazardous materials, including oil. 11. For assistance in determining whether a waste is hazardous, contact the San Diego County Hazardous Materials Division at 858-505-6880. Additional agencies may need to be contacted in the event of a significant spill.
Reference	CASQA WM-4 Caltrans WM-04
Picture	

Type	Description
Concrete Waste Management	<ol style="list-style-type: none"> 1. Containing and disposing of concrete waste to prevent it from being discharged to the storm drain system. 2. Concrete Waste Management should occur at every construction project where concrete or slurries containing PCC or AC is generated, placed, saw cut, cored, grinded, or demolished. 3. Inform all employees and subcontractors that washout from concrete trucks and concrete waste should be collected in concrete washout. 4. Wash out concrete equipment/trucks offsite or in a contained area, so there is no discharge into the underlying soil or onto surrounding areas. 5. Let concrete harden and dispose of as waste. Concrete washouts should be watertight and prevent any concrete waste from being able to discharge to the storm drain system or watercourses. 6. Avoid allowing concrete washout to become greater than 75% full. 7. Cover waste disposal containers securely at the end of every work day and prior to wet weather. 8. Concrete washout facilities shall be located a minimum of 50 ft from storm drain systems and watercourses. 9. Concrete demolition debris may be stored and disposed by following the stockpile management BMP and solid waste management BMP, respectively.
Reference	CASQA WM-8, WM-3 Caltrans WM-08
Picture	

Chapter 5: Required Best Management Practices



Type	Description
Sanitary/ Septic and Liquid Waste Management	<ol style="list-style-type: none"> 1. Sanitary/septic waste management practices are implemented on all construction sites that use temporary or portable sanitary/septic waste systems in order to minimize or eliminate the discharge of construction site sanitary/septic waste materials to the storm drain system or to watercourses. 2. Temporary sanitary facilities shall be located away from drainage facilities, watercourses, and from traffic circulation. 3. When subjected to high winds or risk of high winds, as determined by the Engineer, temporary sanitary facilities shall be secured to prevent overturning. 4. Wastewater shall not be discharged or buried within the street right-of-way. 5. Ensure that sanitary/septic facilities are maintained in good working order by a licensed service. Only reputable, licensed sanitary/septic waste haulers may be used. 6. Liquid waste discharges, such as drilling residue, drilling fluids, water-laden dredged material, and drilling mud, to the storm drain system or to watercourses as a result of the creation, collection, and disposal of non-hazardous is prohibited. 7. Liquid waste management is applicable to construction projects that generate any of the following non-hazardous liquid wastes: drilling slurries and fluids, grease and oil-free wastewater and rinse water, dredgings, and other non-storm water liquid discharges not permitted by separate permits. 8. Liquid wastes must be contained in a structurally sound and leak free container and controlled area, such a holding pit, sediment basin, or portable tank. Liquid waste discharges shall always be in a controlled environment. Use temporary dikes or berms to intercept flows and direct them to a containment area for capture. 9. If the liquid waste is sediment laden, use a sediment trap for capturing and treating the liquid waste stream, or capture in a containment device, vacuum and dispose. If necessary, further treat liquid wastes prior to disposal. Treatment may include, though is not limited to, sedimentation, filtration, and chemical neutralization.
Reference	CASQA WM-9, WM-10
Picture	

Table 5-3. Non-Storm Water Management:

Type	Description
Dewatering Operations	<ol style="list-style-type: none"> 1. Managing and/or treating the discharge of non-storm water (groundwater, water used during pipeline flushing, incidental trench water, or other water used during construction activities) or accumulated storm water to prevent unauthorized discharge. The primary concern with accumulated storm water is sediment. 2. Non-storm water and accumulated storm water should be pumped to another area on the site for infiltration to eliminate the need to discharge. 3. If discharge is necessary, common methods for reducing sediment from a discharge are sediment traps / basins, weir tanks, dewatering tanks, filter bags / socks, media / cartridge filters. 4. A filtration device may be substituted for a desilting basin or sediment trap if the Contractor can demonstrate, to the Engineer’s satisfaction, that the filtration device provides equivalent or greater removal of suspended solids than the basin. 5. Filter bags may be used for small-scale dewatering operations. 6. Effectively manage all dewatering run-on/run-off within the site, and all dewatering runoff that discharges from the site. 7. Divert run-on water from offsite away from all disturbed areas or otherwise ensure compliance. 8. Ensure that dewatering discharges do not cause erosion at the discharge point. 9. Projects must comply with all sampling requirements of applicable NPDES permits and associated numeric limits. 10. When dewatering, notify and obtain approval from the City prior to discharging into the street, gutter, or storm drain. If allowed to discharge to the street, the gutter from the discharge point to the inlet must be swept clean prior to discharge. 11. If the area has known contamination, testing is required prior to reusing or discharging the groundwater. Contaminated groundwater must be treated or hauled off-site for proper disposal.
Reference	CASQA NS-2 Caltrans NS-02
Picture	

Chapter 5: Required Best Management Practices



Type	Description
Illicit Connection/ Illegal Discharge Detection and Reporting	<p>Illicit connection/illegal discharge detection and reporting is applicable anytime an illicit discharge is discovered or illegally dumped material is found on the construction site.</p> <ul style="list-style-type: none"> • Contractor shall inspect the site before beginning the job for evidence of illicit connections or illegal dumping or discharges, and shall promptly notify the Resident Engineer of such conditions. • Contractor shall observe site perimeter for evidence or potential of illicitly discharged or illegally dumped material that may enter the job site. • Contractor shall inspect the site regularly during construction for evidence of illicit connections or illegal dumping or discharges.
Reference	CASQA NS-6
Picture	

Table 5-4. Erosion Control

Type	Description
Seeding	<ol style="list-style-type: none"> 1. Applying seed to a surface with the intention of achieving vegetation which can effectively protect soils from erosion while reducing runoff by encouraging infiltration / transpiration. 2. Scarifying or otherwise preparing soil surfaces prior to seed application increases the likelihood and effectiveness of vegetation establishment. 3. Seeding is effective for temporary and permanent stabilization of slopes, stock piles, and other disturbed soils. 4. Seeds can be combined with mulch and water then sprayed onto surfaces (also referred to as hydro seeding) for immediate erosion protection. 5. Without combining or covering seeds with mulch, seeds will be susceptible to erosion until vegetation has sufficiently established. 6. Supplemental irrigation may be required to establish vegetation.
Reference	CASQA EC-4 Caltrans SS-04
Picture	

Chapter 5: Required Best Management Practices

Type	Description
Soil Binders	<ol style="list-style-type: none"> 1. Spraying a liquid compound to disturbed soils to bind and stabilize the soil surface (forming a crust). 2. This process reduces the potential for wind and water erosion until vegetation is established. Examples include: guar, psyllium, starch, gypsum, pitch and rosin emulsion, polymers, and acrylates. 3. Soil binders are effective for temporary stabilization of slopes, stockpiles, and other disturbed areas. 4. Soil binders need time to cure and should not be applied less than 24 hours before predicted precipitation. 5. The specific soil binder selected depends on the type of soil. 6. Soil binders must be non-toxic and approved for project-specific application based on environment conditions. 7. Soil binders will need to be reapplied as needed based on the specific soil binder and visual inspection. 8. Soil binders are much less effective in areas that receive traffic.
Reference	<p>CASQA EC-5 Caltrans SS-05</p>
Picture	

Chapter 5: Required Best Management Practices

Type	Description
Mulching	Covering disturbed soils with a fibrous wood, straw, or similar material to protect the bare soil from rainfall impact erosion while reducing runoff by encouraging infiltration / evaporation. Mulching is effective for temporary stabilization of slopes, stockpiles, and other disturbed soils. Mulch materials can be combined with water then sprayed onto surfaces (also referred to as hydraulic mulch) for increased wind erosion protection. Typically, mulch must be reapplied every 6 to 12 months. Soil roughening prior to mulch application can increase its effectiveness.
Reference	CASQA EC-3, EC-6, EC-8 Caltrans SS-03, SS-06, SS-08
Picture	

Chapter 5: Required Best Management Practices

Type	Description
Geotextiles and Mats	Covering disturbed soils with a natural or synthetic blanket or mat. This process greatly reduces the potential for wind and water erosion. Some rolls and mats physically hold the soil in place. Example include: geotextiles, plastic covers, rolled erosion control blankets / mats, straw / mulch blanket, coconut fiber blanket, and plastic netting. Geotextiles and mats are effective for temporary stabilization of steep slopes with high erosion potential, stockpiles, and channels that will be vegetated. Geotextiles and mats are more expensive than other erosion control BMPs. Materials should be selected considering CGP NOT requirements as applicable (e.g., plastic netting may not be allowable if blankets to remain in place after termination). Mats / blankets typically require an anchoring mechanism to hold them in place. Mats / blankets should allow water to flow on top of them and not below which would cause the soil to wash out.
Reference	CASQA EC-7 Caltrans SS-07
Picture	

Chapter 5: Required Best Management Practices

Type	Description
Non-Vegetative Stabilization	Covering disturbed soils with a non-vegetative material to protect the bare soil from rainfall impact erosion while reducing runoff by encouraging infiltration / evaporation. Examples include: decomposed granite, gravel, and rock slope protection. Non-vegetative stabilization is effective for temporary and permanent stabilization of areas with heavy vehicular or pedestrian traffic or areas where a vegetative cover is infeasible. Non-vegetative stabilization is to be used in combination with other temporary or permanent erosion control and sediment control BMPs. Material should be selected based on the slope and use of the area.
Reference	CASQA EC-16 Caltrans Standard Specifications May 2006 Section 72-2.
Picture	

Chapter 5: Required Best Management Practices



Type	Description
Soil Roughening	<p>Mechanically roughening soil (track walking or imprinting) to prepare soil for additional BMPs or create small terraces to break up sheet flow. Soil roughening can be applied to slopes, stockpiles, basins, and other disturbed soil areas. Soil roughening can be very effective at controlling erosion and is required to be used in combination with additional erosion control and sediment control BMPs. A common implementation method is to drive heavy equipment with its treads parallel to the contours of the slope. For long slopes additional terracing may be required.</p>
Reference	CASQA EC-15
Picture	

Table 5-5. Sediment Control

Type	Description
Perimeter Controls	Installing a barrier to prevent sediment discharges by controlling run-on and run-off around the perimeter of the construction site or limits of grading. Examples include: silt fence, fiber rolls, gravel bags, and straw bales. Perimeter controls are effective when implemented around the perimeter of the construction site or limits of grading. Perimeter controls are not effective when used in a concentrated flow path. Silt fence and fiber rolls require proper installation which includes trenching and staking. Typically, perimeter controls should be installed prior to grading and remain functional until final stabilization is achieved. Maintenance of perimeter controls must be performed as needed.
Reference	CASQA SE-1, SE-5, SE-6, SE-8, SE-14 Caltrans SC-01, SC-05, SC-06, SC-08
Picture	

Chapter 5: Required Best Management Practices

Type	Description
Storm Drain Inlet Protection	<ol style="list-style-type: none"> 1. Filtering of storm water before it enters a storm drain inlet with appropriate BMP's reduces the sediment discharge amount. 2. Storm drain inlet protection should be implemented at every storm drain inlet that receives runoff from active construction areas. 3. Inlet protection should be designed to consider ponding and traffic safety as applicable. 4. At low points and areas prone to flooding, inlet protection shall be removed until flooding is no longer in driving lanes; replace inlet protection immediate thereafter. 5. Other sediment controls such as check dams, gravel bags, and berms should be used upstream to reduce the amount of sediment that reaches the storm drain inlet protection. 6. After a storm, sediment that has settled must be cleaned up. 7. Remove all inlet protection devices when the inlet protection is no longer needed. 8. All gravel bags placed in the right-of-way shall be stamped /stenciled with the contractor company name.
Reference	CASQA SE-10, SE-14 Caltrans SC-10
Picture	

Chapter 5: Required Best Management Practices

Type	Description
Sediment Trap / Basin	Prevent sediment from migrating offsite by installing and maintaining sediment Trap / Basins. Constructing a temporary containment area to detain runoff to allow for deposition of sediment prior to storm water discharge. Sediments traps / basins are effective when implemented within the downstream section of a construction site or at discharge points. Sediment traps can be effectively implemented throughout a large construction site. Sediment basins can efficiently be developed at locations where future post-construction basins will be utilized. Sediment traps should only be used for tributary drainage areas below 5 acres. Sediment basins should be used for tributary drainage areas between 5 and 75 acres. Sediment traps / basins can be large and may not be suitable for small construction projects. Sediment traps / basins should be sized by a Registered Civil Engineer to ensure they have sufficient capacity and be designed in accordance with CASQA Fact Sheet SE-2.
Reference	CASQA SE-2, SE-3 Caltrans SC-02, SC-03
Picture	

Chapter 5: Required Best Management Practices

Type	Description
Tracking Control	<ol style="list-style-type: none"> 1. Cleaning sediment from public or private streets and roadways to reduce the potential discharge to storm drain inlets or receiving waters. 2. Limit the points of entrance/exit, and speed to the construction site. 3. Route runoff from stabilized entrances/exits through an approved sediment-trapping device before discharge. 4. Properly grade each construction entrance/exit to prevent runoff from leaving the construction site. 5. Sweeping and vacuuming should immediately be implemented on all paved areas within and adjacent to construction sites. Do not sweep up any unknown substance or any object that may be potentially hazardous. Adjust brooms frequently; maximize efficiency of sweeping operations. 6. Street sweepers should be adjusted to eliminate or minimize the amount of runoff generated, especially while standing. Excess sweeper water is an unauthorized non-storm water discharge. 7. Inspect, maintain, and secure areas subject to sediment to prevent tracking on a daily basis. 8. Utilize methods that collect and remove sediment instead of methods that simply spread the sediment around. 9. Never hose down or power wash streets to clean up tracking. 10. Constructing a stabilized surface where sediment can be dislodged from vehicle and equipment tires before being tracked onto off-site paved roads. 11. Stabilized construction entrance / exits should be sufficiently implemented at every construction project to prevent erosion and sediment discharges from site. 12. Construction entrances / exits should be 50 feet or more in length. 13. The most common method is to place 3-6 inch rock at least 1 foot high over filter fabric. 14. Additional rock may need to be added as sediment accumulates. 15. Rumble plates can be added for additional sediment removal. 16. All employees, subcontractors, and suppliers shall be required to utilize the stabilized construction access.
Reference	<p>CASQA TC-1, TC-2, SE-7 Caltrans TC-01, TC-02, SC-07</p>
Picture	

Chapter 5: Required Best Management Practices

Type	Description
Water Conservation Practices	Water conservation practices are activities that use water during the construction of a project in a manner that avoids causing erosion and/or the transport of pollutants offsite. It applies to all construction projects. Contractor must keep water equipment in good working condition by repairing water leaks promptly. Do not use water or toxic agents to clean construction areas. Direct non-contaminated construction water runoff to areas where it can soak into the ground. Apply water for dust control in accordance with the Caltrans Standard Specifications.
Reference	CASQA NS-1

Chapter 5: Required Best Management Practices

Table 5-6. Run-on Run-off Control

Type	Description
Dikes, Swales, and Slope Drains	Grading and compacting soil or installing pipe to control / divert / direct runoff. Dikes, swales, and slope drains can be combined to safely convey runoff down a slope, direct runoff to a stabilized channel, reduce potential for flooding, direct runoff to sediment traps / basins. Dikes, swales, and pipes that are used to direct runoff must be properly sized based on the specific application. Typically, slope drains require energy dissipation. Monitor swales and dikes for erosion or accumulation of sediment or debris. Swale and dike slopes should be 2:1 or less. Use vegetation, geotextiles, or mats to stabilize swales. Temporary devices must be removed.
Reference	CASQA EC-9, EC-11 Caltrans SS-09, SS-11
Picture	

Chapter 5: Required Best Management Practices

Type	Description
Energy Dissipation	Placing rock, riprap, or similar material to reduce erosion from concentrated, high velocity flows. Energy dissipation is effective at pipe outlets, channel linings, and transitions from stabilized to un-stabilized conveyances. Line the area with filter fabric prior to placing rock or riprap. Accumulated sediment may be difficult to remove from energy dissipation area. For pipe outfalls the size of the energy dissipation area will increase with flow rate and/or pipe size. Temporary devices must be removed.
Reference	CASQA EC-10 Caltrans SS-10
Picture	

Chapter 5: Required Best Management Practices

Table 5-7. Active/Passive Sediment Treatment

Type	Description
Active Treatment System	As required by the CGP, Active Treatment Systems can reliably provide exceptional reductions of turbidity and associated pollutants and should be considered where turbid discharges to sediment and turbidity sensitive waters cannot be avoided using traditional BMPs. Additionally, it may be appropriate to use an Active Treatment System when site constraints inhibit the ability to construct a correctly sized sediment basin, when clay and/or highly erosive soils are present, or when the site has very steep or long slope lengths.
Reference	CASQA SE-11
Picture	
Passive Treatment	Passive Treatment Systems are practices that incorporate a chemical flocculant to reduce turbidity in construction site runoff but do not rely on computerized systems with pumps, filters and real-time controls. Projects with coverage under the CGP should review current requirements for passive treatment. Passive Treatment Systems may trigger numeric action levels.

5.1. Implementation

BMPs shall be designed and implemented to control off-site discharges and prevent sediment-laden water and other pollutants from impacting adjacent properties or entering the City's public storm system and/or adjacent or downstream rivers, streams, and sensitive areas. BMPs shall be designed and implemented so as not to adversely affect any public Right of Way. Down gradient sediment controls (e.g., perimeter controls, inlet protection or sediment traps) shall be implemented prior to the start of any earth disturbing activity.

5.2. Effectiveness

BMPs shall be routinely evaluated for their effectiveness. Self-inspection shall be used to determine the effectiveness of BMPs. Section 7.2 provides guidance on self-inspections. Additional BMPs shall be implemented as dictated by site conditions throughout all phases of the project. The contractor shall contact the SWPPP developer or WPCP preparer as applicable if BMPs are found to be ineffective. As described in Chapter 7, the city inspector may require additional measures depending on individual site conditions.

5.3. Maintenance

BMP measures stated in the SWPPP or WPCP, as applicable, shall be maintained in fully functional condition until no longer required for a completed phase of work or final stabilization has been achieved.

5.4. Project Close-Out

For projects with coverage under the CGP, projects must be closed in accordance with termination requirements in the CGP. The Engineer of Record shall submit a completed DS-563 certification of post construction BMPs to the City prior to close-out. For capital improvement projects, the form is filled out on the D-sheet as part of the as-built process. DS-563 can be found in Appendix D.

For all other projects, the project owner must verify the following:

1. All disturbed areas have been stabilized in accordance with the project's landscaping and paving plan.
2. All BMPs, construction materials, and construction wastes have been removed from the site.

Chapter 5: Required Best Management Practices

THIS PAGE INTENTIONALLY LEFT BLANK FOR DOUBLE-SIDED PRINTING

APPENDIX VII
BMP INFORMATION

QSP IMPLEMENTATION CHECKLIST (Store Completed Forms in Appendix VII)

The QSP completes this checklist prior to each phase of construction.

Phase of construction: Grading & Land Development Phase Vertical Construction Phase
 Streets & Utilities Phase Final Landscaping & Site Stabilization Phase

A. Good Site Management ("Housekeeping") Measures for Construction Materials:

Construction Materials Measures ID No.	Construction Materials Measures	BMP Option		Alternative BMP Option *Describe why BMP was not implemented	
		Implemented?			
		Y	N*		
CM-a	Conduct an inventory of the products used and/or expected to be used and the end products that are produced and/or expected to be produced. ¹	QSP must conduct an inventory	X		
CM-b	Cover and berm loose stockpiled construction materials that are not actively being used (i.e. soil, spoils, aggregate, fly-ash, stucco, hydrated lime, etc.).	BMP-2-01 BMP-2-02 BMP-2-03 BMP-2-04 BMP-2-05 BMP-2-06	X		
CM-c	Store chemicals in watertight containers (with appropriate secondary containment to prevent any spillage or leakage) or in a storage shed (completely enclosed).	BMP-2-01 BMP-2-02 BMP-2-03 BMP-2-04 BMP-2-05 BMP-2-06 BMP-2-07 BMP-2-08	X		
CM-d	Minimize exposure of construction materials with precipitation.	BMP 1-07	X		

¹ QSP to review List of Potential Pollutant Sources in Appendix V and complete an Inventory of Potential Pollutant Sources planned to be used or stored at the project site in Appendix V as well.

B. Good Site Management ("Housekeeping") Measures for Waste Management:

Construction Materials Measures ID No.	Construction Materials Measures	BMP Option			Alternative BMP Option
			Implemented?		*Describe why BMP was not implemented
			Y	N*	
WM-a	Prevent disposal of any rinse or wash waters or materials on impervious or pervious site surfaces or into the storm drain system.	BMP 3-02 BMP 3-03 BMP 3-04 BMP 3-05 BMP 3-06 BMP 3-07 BMP 3-08 BMP 3-09	X		
WM-b	Ensure the containment of sanitation facilities (e.g., portable toilets) to prevent discharges of pollutants to the storm water drainage system or receiving water.	BMP 2-07	X		
WM-c	Clean or replace sanitation facilities and inspecting them regularly for leaks and spills.	BMP 2-07	X		
WM-d	Cover waste disposal containers at the end of every business day and during a rain event.	BMP 2-01 BMP 2-02 BMP 2-03 BMP 2-04 BMP 2-05 BMP 2-06 BMP 2-07 BMP 2-08	X		
WM-e	Prevent discharges from waste disposal containers to the storm water drainage system or receiving water.	BMP 2-01 BMP 2-02 BMP 2-03 BMP 2-04 BMP 2-05 BMP 2-06 BMP 2-07 BMP 2-08	X		
WM-f	Contain and securely protect stockpiled waste material from wind and rain at all times unless actively being used.	BMP 1-08	X		
WM-g	Implement procedures that effectively address hazardous and non-hazardous spills.	BMP 2-03	X		
WM-h	Develop a spill response and implementation element of the SWPPP prior to commencement of construction activities. The SWPPP shall require that: <ul style="list-style-type: none"> • Equipment and materials for cleanup of spills shall be available on site and that spills and leaks shall be cleaned up immediately and disposed of properly; and • Appropriate spill response personnel are assigned and trained. 	BMP 2-03	X		

B. Good Site Management ("Housekeeping") Measures for Waste Management:

Construction	Construction Materials Measures	BMP Option			Alternative BMP Option
WM-i	Ensure the containment of concrete washout areas and other washout areas that may contain additional pollutants so there is no discharge into the underlying soil and onto the surrounding areas.	BMP 2-04	X		

C. Good Site Management ("Housekeeping") Measures for Vehicle Storage and Maintenance:

Construction Materials Measures		BMP Option			Alternative BMP Option
		Implemented?		*Describe why BMP was not implemented	
		Y	N*		
VSM-a	Prevent oil, grease, or fuel to leak in to the ground, storm drains or surface waters.	BMP 3-03 BMP 3-04 BMP 3-05	X		
VSM-b	Place all equipment or vehicles, which are to be fueled, maintained and stored in a designated area fitted with appropriate BMPs.	BMP 2-03 BMP 2-02 BMP 3-03 BMP 3-04	X		
VSM-c	Clean leaks immediately and disposing of leaked materials properly.	BMP 2-03	X		

D. Good Site Management ("Housekeeping") Measures for Landscape Materials:

Landscape Materials Measures		BMP Option			Alternative BMP Option
		Implemented?		*Describe why BMP was not implemented	
		Y	N*		
LM-a	Contain stockpiled materials such as mulches and topsoil when they are not actively being used.	BMP 1-08 BMP 4-07 BMP 4-02	X		
LM-b	Contain fertilizers and other landscape materials when they are not actively being used.	BMP 1-08 BMP 2-01 BMP 2-02	X		
LM-c	Discontinuing the application of any erodible landscape material within 2 days before a forecasted rain event ² or during periods of precipitation.	BMP 3-07 BMP 2-02	X		
LM-d	Apply erodible landscape material at quantities and application rates according to manufacture recommendations or based on written specifications by knowledgeable and experienced field personnel.	BMP 3-07 BMP 2-02	X		
LM-e	Stacking erodible landscape material on pallets and covering or storing such materials when not being used or applied.	BMP 3-07 BMP 2-01 BMP 2-02	X		

² Excerpt from CGP – 50% or greater chance of producing precipitation.

F. Good Site Management ("Housekeeping") Measures for Air Deposition:

Air Deposition		BMP Option		Alternative BMP Option *Describe why BMP was not implemented
		Implemented?		
		Y	N*	
AD-a	Control the air deposition of site materials and from site operations. Such particulates can include, but are not limited to, sediment, nutrients, trash, metals, bacteria, oil and grease and organics.	BMP 4-08	X	

Non-Storm Water Management:		BMP Option		Alternative BMP Option *Describe why BMP was not implemented
		Implemented?		
		Y	N*	
NSWM-a	Implement measures to control all non-storm water discharges during construction.	BMP 3-03 BMP 3-02 BMP 1-07	X	
NSWM-b	Wash vehicles in such a manner as to prevent non-storm water discharges to surface waters or MS4 drainage systems.	BMP 3-03		X Washing of vehicles will not be conducted on the project site per SDG&E policy.
NSWM-c	Clean streets in such a manner as to prevent non-storm water discharges from reaching surface water or MS4 drainage systems.	BMP 3-02 BMP 1-07	X	

Erosion Control		BMP Option		Alternative BMP Option *Describe why BMP was not implemented
		Implemented?		
		Y	N*	
ECM-a	Effective wind erosion control	BMP 4-08	X	
ECM-b	Provide effective soil cover for inactive ³ areas and all finished slopes, open space, utility backfill, and completed lots.	BMP 4-02 BMP 4-03 BMP 4-04 BMP 4-05 BMP 4-06 BMP 4-07	X	
ECM-c	Limit the use of plastic materials when more sustainable, environmentally friendly alternatives exist. Where plastic materials are deemed necessary, the discharger shall consider the use of plastic materials resistant to solar degradation.	BMP 4-07	X	

³ Inactive areas of construction are areas of construction activity that have been disturbed and are not scheduled to be re-disturbed for at least 14 days.

Sediment Control		BMP Option		Alternative BMP Option	
			Implemented?		*Describe why BMP was not implemented
			Y	N*	
SC-a	Establish and maintain effective perimeter controls and stabilize all construction entrances and exits to sufficiently control erosion and sediment discharges from the site.	BMP 1-01 BMP 1-02 BMP 1-03 BMP 1-04 BMP 1-05 BMP 1-06 BMP 1-07 BMP 1-08	X		
SC-b	On sites where sediment basins are to be used, at a minimum, design sediment basins according to the method provided in CASQA's Construction BMP Guidance Handbook	N/A		X	No sediment basins to be used.
SC-c	Apply linear sediment controls along the toe of the slope, face of the slope, and at the grade breaks of exposed slopes to comply with sheet flow lengths ⁴ in accordance with Table 1.	BMP 1-02 BMP 1-03	X		
SC-d	Ensure that construction activity traffic to and from the project is limited to entrances and exits that employ effective controls to prevent offsite tracking of sediment.	BMP 1-07	X		
SC-e	Ensure that all storm drain inlets and perimeter controls, runoff control BMPs, and pollutant controls at entrances and exits (e.g. tire washoff locations) are maintained and protected from activities that reduce their effectiveness.	BMP 1-06	X		
SC-f	Inspect on a daily basis all immediate access roads daily. At a minimum daily (when necessary) and prior to any rain event, the discharger shall remove any sediment or other construction activity-related materials that are deposited on the roads (by vacuuming or sweeping).	BMP 1-07	X		
SC-g	The Regional Water Board may require Risk Level 3 dischargers to implement additional site-specific sediment control requirements if the implementation of the other requirements in this section are not adequately protecting the receiving waters.	N/A		X	

⁴ Sheet flow length is the length that shallow, low velocity flow travels across a site.

Table 1 - Critical Slope/Sheet Flow Length Combinations

Slope Percentage	Sheet flow length not to exceed
0-25%	20 feet
25-50%	15 feet
Over 50%	10 feet

Run-on and Run-off Controls		Applicable to Project?		Alternative BMP Option
		Y	N*	*Describe why BMP was not implemented
RRC-a	Effectively manage all run-on, all runoff within the site and all runoff that discharges off the site.	X		
RRC-b	Run-on from off-site shall be directed away from all disturbed areas or shall collectively be in compliance with the effluent limitation in the CGP.	X		

APPENDIX VIII
LUP TYPE REQUIREMENTS

Appendix VIII

C. Risk Type 1 Requirements

I RISK TYPE DETERMINATION

A Risk Type Determination has been conducted for the Sycamore - Peñasquitos 230 kV Transmission Line Project and the following areas within the project have been determined to be **Risk Type 1**. The documentation for the Risk Type is located in Appendix IV.

Risk Type 1 Areas

Area	From	To
	GPS\Description	GPS\Description
Segment 1A: Sycamore Canyon Substation to MCAS Miramar Boundary	32.91733°N, - 117.03073°W	32.91983°N, - 117.03223°W
Segment 2A: MCAS Miramar Boundary to P5; including staging yards Stowe and Stonebridge	32.91983°N, - 117.03223°W	32.92250°N, - 117.04244°W
Segment 3B: P5 to 1-15 Bridge	32.92250°N, - 117.04244°W	32.89347°N, - 117.11358°W
Segment 4B: 1-15 Bridge Crossing	32.89347°N, - 117.11358°W	32.89361°N, - 117.11801°W
Segment 5B: 1-15 to Carroll Canyon; including staging yards Site 1A, Site 1B, Site 2, Site 3, Shire Property (Sites 4A-4C), and Driving Range (Site 5)	32.89361°N, - 117.11801°W	32.88984°N, - 117.20303°W
Segment 8C: Costal Zone Boundary North End to Peñasquitos Substation	32.91185°N, -117.21662°W	32.91825°N, -117.21923°W

II EFFLUENT STANDARDS

The following effluent standards are applicable to Risk Type 1 areas.

A. Narrative Effluent Standards

These areas must meet the following narrative effluent standards:

- Dischargers shall ensure that storm water discharges and authorized non-storm water discharges regulated by this General Permit do not contain a hazardous substance equal to or in excess of reportable quantities established in 40 C.F.R. §§ 117.3 and 302.4, unless a separate NPDES Permit has been issued to regulate those discharges.
- Dischargers shall minimize or prevent pollutants in storm water discharges and authorized non-storm water discharges through the use of structural or non-structural controls, structures, and management practices that achieve BAT for toxic and nonconventional pollutants and BCT for conventional pollutants.

B. Numeric Effluent Standards

Risk Type 1 areas are not subject to numeric effluent standards.

III SPECIFIC REQUIREMENTS

The following sections describe specific measures to be implemented for Risk Type 1 areas of the project. Tables have been provided for each measure described in the CGP Attachment A that is applicable to a Risk Type 1 area.

The first column of the table provides a measure identification number that corresponds to the applicable measure in the next column. The measures listed in the second column are required for a Risk Type 1 area.

The second column includes the substance of the Risk Type-specific requirements from the CGP.

The third column of the table describes whether this measure is applicable to the project.

The fourth column provides one or more BMP options that correspond to each required measure. These BMP Options(s) are references to the SDG&E/SCG Water Quality Construction Best Management Practices Manual (or "BMP Manual").

The fifth column of the table identifies the location within the SWPPP that contains the information applicable to the fourth column. The information in the fourth column is either a BMP Option or an inventory form.

Locations of the applicable measures and BMP Options are identified on the SWPPP Site Map located in Appendix III. The initial layout of the BMPs has been identified by the QSD as part of the preparation of the SWPPP. As site conditions change, it is the responsibility of the QSD to make all revisions necessary.

The QSD prepared the tables below as part of the preparation of this SWPPP. It is the responsibility of the QSP to review these tables during the course of the project and advise the QSD to update the SWPPP as applicable. In addition, a QSP Implementation Checklist has been provided in Appendix VII to document the updates as applicable.

A. Good Site Management Housekeeping

This section addresses good site management (i.e., "housekeeping") practices, including practices for:

1. Construction Materials
2. Waste Management
3. Vehicle Storage and Maintenance
4. Landscape Maintenance
5. Assessment of Potential Pollutant Sources

6. Air Deposition

Tables have been provided for each good housekeeping measure described in the following sections, with the exception of Assessment of Potential Pollutant Sources (Section 5) and Air Deposition (Section 6). Section 5 describes specific actions that **must** be taken to comply with the permit.

Each of the following measures is an element of Good Site Management “Housekeeping” as described in the CGP.

1. Good Site Management (“Housekeeping”) Measures for Construction Materials at a minimum, shall consist of the following:

Construction Materials Measure ID No.	Construction Materials Measure	Applicable to Project?		BMP Option (check applicable option(s))	Location in SWPPP
		Yes	No ***		
CM-a	Conduct an inventory of the products used and/or expected to be used and the end products that are produced and/or expected to be produced ¹ .	X		QSP must conduct an inventory	Appendix V
CM-b	Cover and berm loose stockpiled construction materials that are not actively being used (i.e. soil, spoils, aggregate, fly-ash, stucco, hydrated lime, etc.).	X		<input checked="" type="checkbox"/> BMP 1-08	Appendix VI
CM-c	Store chemicals in watertight containers (with appropriate secondary containment to prevent any spillage or leakage) or in a storage shed (completely enclosed).	X		<input checked="" type="checkbox"/> BMP 2-01 <input checked="" type="checkbox"/> BMP 2-02 <input checked="" type="checkbox"/> BMP 2-03 <input checked="" type="checkbox"/> BMP 2-04 <input checked="" type="checkbox"/> BMP 2-05 <input checked="" type="checkbox"/> BMP 2-06	Appendix VI
CM-d	Minimize exposure of construction materials to precipitation (not applicable to materials designed to be outdoors and exposed to the environment).	X		<input checked="" type="checkbox"/> BMP 2-01 <input checked="" type="checkbox"/> BMP 2-02 <input checked="" type="checkbox"/> BMP 2-03 <input checked="" type="checkbox"/> BMP 2-04 <input checked="" type="checkbox"/> BMP 2-05 <input checked="" type="checkbox"/> BMP 2-06 <input checked="" type="checkbox"/> BMP 2-07 <input checked="" type="checkbox"/> BMP 2-08	Appendix VI
CM-e	Implement BMPs to prevent the off-site tracking of loose construction and landscape materials.	X		<input checked="" type="checkbox"/> BMP 1-07	Appendix VI

¹ This does not include materials and equipment that are designed to be outdoors and exposed to environmental conditions (i.e. poles, equipment pads, cabinets, conductors, insulators, bricks, etc.).

***** If BMP is not applicable, explain here.**

2. Good Site Management (“Housekeeping”) Measures for Waste Management at a minimum, shall consist of the following:

Waste Management Measure ID No.	Waste Management Measure	Applicable to Project?		BMP Option (check applicable option(s))	Location in SWPPP
		Yes	No***		
WM-a	Prevent disposal of any rinse or wash waters or materials on impervious or pervious site surfaces or into the storm drain system.	X		<input checked="" type="checkbox"/> BMP 3-02 <input type="checkbox"/> BMP 3-03 <input checked="" type="checkbox"/> BMP 3-04 <input checked="" type="checkbox"/> BMP 3-05 <input checked="" type="checkbox"/> BMP 3-06 <input type="checkbox"/> BMP 3-07 <input type="checkbox"/> BMP 3-08 <input checked="" type="checkbox"/> BMP 3-09	Appendix VI
WM-b	Ensure the containment of sanitation facilities (e.g., portable toilets) to prevent discharges of pollutants to the storm water drainage system or receiving water.	X		<input checked="" type="checkbox"/> BMP 2-07	Appendix VI
WM-c	Clean or replace sanitation facilities and inspecting them regularly for leaks and spills.	X		<input checked="" type="checkbox"/> BMP 2-07	Appendix VI
WM-d	Cover waste disposal containers at the end of every business day and during a rain event.	X		<input checked="" type="checkbox"/> BMP 2-01 <input checked="" type="checkbox"/> BMP 2-02 <input checked="" type="checkbox"/> BMP 2-03 <input checked="" type="checkbox"/> BMP 2-04 <input checked="" type="checkbox"/> BMP 2-05 <input checked="" type="checkbox"/> BMP 2-06 <input checked="" type="checkbox"/> BMP 2-07 <input checked="" type="checkbox"/> BMP 2-08	Appendix VI
WM-e	Prevent discharges from waste disposal containers to the storm water drainage system or receiving water.	X		<input checked="" type="checkbox"/> BMP 2-01 <input checked="" type="checkbox"/> BMP 2-02 <input checked="" type="checkbox"/> BMP 2-03 <input checked="" type="checkbox"/> BMP 2-04 <input checked="" type="checkbox"/> BMP 2-05 <input checked="" type="checkbox"/> BMP 2-06 <input checked="" type="checkbox"/> BMP 2-07 <input checked="" type="checkbox"/> BMP 2-08	Appendix VI
WM-f	Contain and securely protect stockpiled waste material from wind and rain at all times unless actively being used.	X		<input checked="" type="checkbox"/> BMP 1-08	Appendix VI
WM-g	Implement procedures that effectively address hazardous and non-hazardous spills.	X		<input checked="" type="checkbox"/> BMP 2-03	Appendix VI

2. Good Site Management (“Housekeeping”) Measures for Waste Management at a minimum, shall consist of the following:

Waste Management Measure ID No.	Waste Management Measure	Applicable to Project?		BMP Option (check applicable option(s))	Location in SWPPP
		Yes	No***		
WM-h	Develop a spill response and implementation element of the SWPPP prior to commencement of construction activities. The SWPPP shall require that: <ul style="list-style-type: none"> • Equipment and materials for cleanup of spills shall be available on site and that spills and leaks shall be cleaned up immediately and disposed of properly; and • Appropriate spill response personnel are assigned and trained. 	X		<input checked="" type="checkbox"/> BMP 2-03	-Appendix VI. -For spill response personnel, see Appendix XIII. -For relevant training see Appendix XV.
WM-i	Ensure the containment of concrete washout areas and other washout areas that may contain additional pollutants so there is no discharge into the underlying soil and onto the surrounding areas.	X		<input checked="" type="checkbox"/> BMP 2-04	Appendix VI

***** If BMP is not applicable, explain here.**

3. Good Site Management (“Housekeeping”) Measures for Vehicle Storage and Maintenance , at a minimum, shall consist of the following:

Vehicle Storage and Maintenance Measure ID No.	Vehicle Storage and Maintenance Measure	Applicable to Project?		BMP Option (check applicable option(s))	Location in SWPPP
		Yes	No***		
VSM-a	Prevent oil, grease, or fuel to leak in to the ground, storm drains or surface waters.	X		<input type="checkbox"/> BMP 3-03 <input checked="" type="checkbox"/> BMP 3-05	Appendix VI
VSM-b	Implement appropriate BMPs wherever equipment or vehicles are fueled, maintained or stored.	X		<input checked="" type="checkbox"/> BMP 2-03 <input checked="" type="checkbox"/> BMP 2-02 <input type="checkbox"/> BMP 3-03 <input checked="" type="checkbox"/> BMP 3-04	Appendix VI
VSM-c	Clean leaks immediately and disposing of leaked materials properly.	X		<input checked="" type="checkbox"/> BMP 2-03	Appendix VI

*** If BMP is not applicable, explain here.

4. Good Site Management (“Housekeeping”) Measures for Landscape Materials at a minimum, shall consist of the following:

Landscape Materials Measure ID No.	Landscape Materials Measure	Applicable to Project?		BMP Option (check applicable option(s))	Location in SWPPP
		Yes	No***		
LM-a	Contain stockpiled materials such as mulches and topsoil when they are not actively being used.	X		<input checked="" type="checkbox"/> BMP 1-08 <input checked="" type="checkbox"/> BMP 4-07 <input checked="" type="checkbox"/> BMP 4-02	Appendix VI
LM-b	Contain fertilizers and other landscape materials when they are not actively being used.	X		<input checked="" type="checkbox"/> BMP 1-08 <input checked="" type="checkbox"/> BMP 2-01 <input checked="" type="checkbox"/> BMP 2-02	Appendix VI
LM-c	Discontinuing the application of any erodible landscape material within 2 days before a forecasted rain event ² or during periods of precipitation.	X		<input type="checkbox"/> BMP 3-07 <input checked="" type="checkbox"/> BMP 2-02	Appendix VI
LM-d	Apply erodible landscape material at quantities and application rates according to manufacture recommendations or based on written specifications by knowledgeable and experienced field personnel.	X		<input type="checkbox"/> BMP 3-07 <input checked="" type="checkbox"/> BMP 2-02	Appendix VI
LM-e	Stacking erodible landscape material on pallets and covering or storing such materials when not being used or applied.	X		<input type="checkbox"/> BMP 3-07 <input checked="" type="checkbox"/> BMP 2-01 <input checked="" type="checkbox"/> BMP 2-02	Appendix VI

² Excerpt from CGP – 50% or greater chance of producing precipitation.

*** If BMP is not applicable, explain here.

5. Good Housekeeping for Assessment of Potential Pollutant Sources

Pollutant sources will be dynamic over the life of the construction project due to the various phases of construction.

An assessment of construction materials that may be used and activities that will be performed during this project that may have the potential to contribute pollutants, other than sediment, to storm water runoff for the project is located in Appendix V. The QSP must review the list throughout the life of the project and update it accordingly. Appropriate revisions to the SWPPP based on any changes to the list shall be made by the QSD.

In addition, a history of leaks or spills is maintained in Appendix XIV.

6. Good Housekeeping for Control of Air Deposition

This project shall implement good housekeeping measures on the construction site related to Air Deposition:

Air Deposition Measure ID No.	Air Deposition Measure	Applicable to Project?		BMP Option (check applicable option(s))	Location in SWPPP
		Yes	No***		
AD-a	Control the air deposition of site materials and from site operations.	X		<input checked="" type="checkbox"/> BMP 4-08	Appendix VI

***** If BMP is not applicable, explain here.**

B. Non-Storm Water Management

All non-storm water discharges are required to be controlled. BMPs must be implemented for construction related activities that are potential sources of discharges other than storm water.

Implement the following measures to control all **Non-Storm Water Discharges** during construction:

Non-Storm Water Management Measure ID No.	Non-Storm Water Measure	Applicable to Project?		BMP Option (check applicable option(s))	Location in SWPPP
		Yes	No***		
NSWM-a	Implement measures to control all non-storm water discharges during construction.	X		<input type="checkbox"/> BMP 3-03 <input checked="" type="checkbox"/> BMP 3-02 <input checked="" type="checkbox"/> BMP 1-07	Appendix VI
NSWM-b	Wash vehicles in such a manner as to prevent non-storm water discharges to surface waters or MS4 drainage systems.		X	<input type="checkbox"/> BMP 3-03	Appendix VI
NSWM-c	Clean streets in such a manner as to prevent non-storm water discharges from reaching surface water or MS4 drainage systems.	X		<input checked="" type="checkbox"/> BMP 3-02 <input checked="" type="checkbox"/> BMP 1-07	Appendix VI

***** If BMP is not applicable, explain here.**

Vehicle washing will not be performed on the project site per SDG&E policy.

C. Erosion Control Measures

Erosion is the detachment of soil from existing landscapes by water or wind. Erosion is a natural process that can be accelerated by construction activities such as grading or trenching. For example, when a site is cleared or grubbed, protective vegetation is removed and the disturbed soil is directly exposed to wind and water. Erosion controls protect the surface and prevent the soil particles from being detached by rainfall or wind. BMPs for erosion control include soil stabilization.

Erosion Control measures, at a minimum, shall consist of the following:

Erosion Control Measure ID No.	Erosion Control Measure	Applicable to Project?		BMP Option (check applicable option(s))	Location in SWPPP
		Yes	No***		
ECM-a	Implement effective wind erosion control.	X		<input checked="" type="checkbox"/> BMP 4-08	Appendix VI
ECM-b	Provide effective soil cover for inactive ³ areas and all finished slopes and utility backfill.	X		<input checked="" type="checkbox"/> BMP 4-02 <input type="checkbox"/> BMP 4-03 <input checked="" type="checkbox"/> BMP 4-04 <input type="checkbox"/> BMP 4-05 <input type="checkbox"/> BMP 4-06 <input checked="" type="checkbox"/> BMP 4-07	Appendix VI
ECM-c	Limit the use of plastic materials when more sustainable, environmentally friendly alternatives exist. Where plastic materials are deemed necessary, the LRP shall consider the use of plastic materials resistant to solar degradation.	X		<input checked="" type="checkbox"/> BMP 4-07	Appendix VI

³ Excerpt from the CGP: Inactive areas of construction are areas of construction activity that have been disturbed and are not scheduled to be re-disturbed for at least 14 days.

***** If BMP is not applicable, explain here.**

D. Sediment Control Measures

Sediment particles (soil/dust) from construction activities can be transported to a different location by wind or water flow. Sediment controls are usually methods that trap the soil particles after they have detached and have moved by wind or water.

Sediment control measures, at a minimum, shall consist of the following:

Sediment Control Measure	Sediment Control Measure	Applicable to Project?		BMP Option (Check the applicable option(s))	Location in SWPPP
		Yes	No* If not applicable, explain below		
SC-a	Establish and maintain effective perimeter controls as needed, and implement effective BMPs for all construction entrances and exits to sufficiently control erosion and sediment discharges from the site.	X		<input checked="" type="checkbox"/> BMP 1-01 <input checked="" type="checkbox"/> BMP 1-02 <input checked="" type="checkbox"/> BMP 1-03 <input checked="" type="checkbox"/> BMP 1-04 <input type="checkbox"/> BMP 1-05 <input checked="" type="checkbox"/> BMP 1-06 <input checked="" type="checkbox"/> BMP 1-07 <input checked="" type="checkbox"/> BMP 1-08	Appendix VI
SC-b	On sites where sediment basins are to be used, at a minimum, design sediment basins according to the method provided in CASQA's Construction BMP Handbook.		X	N/A	Appendix VI

***** If BMP is not applicable, explain here.**

Sediment basins will not be used on the project.

E. Run-on and Run-off Controls

Run-on and Run-off Controls shall be effectively managed for all run-on/run-off associated with the site and all runoff that discharges off the site, through the following measures. These measures are only required for Risk Type 1 areas when the evaluation of quantity and quality of run-on and run-off deems them necessary or visual inspections show that the site requires such controls.

Run-on and Run-off Control Measures ID No.	Run-on and Run-off Controls	Applicable to Project?		Location in SWPPP
		Yes***	No***	
RRC-a	Effectively manage all run-on, all runoff within the site and all runoff that discharges off the site.	X		Appendix VI
RRC-b	Run-on from off site shall be directed away from all disturbed areas or shall collectively be in compliance with the effluent limitations in Attachment A of the CGP.	X		Appendix VI

***** If BMP is not applicable, explain here. If BMPs are required, describe the BMPs and the locations where they will be implemented.**

If needed, temporary run-on controls may be used to protect excavations from run-on.

IV Inspection, Maintenance and Repair

The purpose of storm water inspections is to evaluate BMP effectiveness and implement repairs or design changes as soon as feasible.

Inspections, maintenance repair and sampling activities shall be conducted by the QSP or a trained individual directed by a QSP.

Daily Visual Inspections

Dischargers shall conduct visual inspections and observations daily during working hours. These inspections do not need to be recorded.

Rain Event Inspections

For each pre- and post-rain event inspection required, Risk Type 1 projects shall complete a site inspection form, located in Appendix IX. Prior to conducting a site inspection, obtain weather information at the following website: <http://www.srh.noaa.gov/forecast>) and attach the information to the inspection form.

Upon identifying failures or other shortcomings, as directed by the QSP, Risk Type 1 projects shall begin implementing repairs or design changes to BMPs within 72 hours of identification and complete the changes as soon as possible.

Inspection Information RequirementsThe inspection forms shall remain onsite with the SWPPP and at a minimum shall include:

- Inspection date and date the inspection report was written.
- Weather information, including presence or absence of precipitation, estimate of beginning of qualifying storm event, duration of event, time elapsed since last storm, and approximate amount of rainfall in inches.
- Site information, including stage of construction, activities completed, and approximate area of the site exposed.
- A description of any BMPs evaluated and any deficiencies noted.
- If the construction site is safely accessible during inclement weather, list the observations of all BMPs: erosion controls, sediment controls, chemical and waste controls, and non-storm water controls. Otherwise, list the results of visual inspections at all relevant outfalls, discharge points, downstream locations and any projected maintenance activities.
- Report the presence of noticeable odors or of any visible sheen on the surface of any discharges.
- Any corrective actions required, including any necessary changes to the SWPPP and the associated implementation dates.
- Photographs taken during the inspection, if any.
- Inspector's name, title, and signature.

Blank inspection forms are located in Appendix I. Completed site inspection forms shall be retained in Appendix IX.

Appendix VIII

B. Risk Type 2 Requirements

I RISK TYPE DETERMINATION

A Risk Type Determination has been conducted for Sycamore - Peñasquitos 230 kV Transmission Line Project and the following area within the project have been determined to be a **Risk Type 2**. The documentation for the Risk Type is located in Appendix IV.

Risk Type 2 Areas

Area	From	To
	GPS\Description	GPS\Description
Segment 6C: Carroll Canyon to Coastal Zone Boundary South End	32.88984°N, -117.20303°W	32.89926°N, -117.20886°W

II EFFLUENT STANDARDS

The following effluent standards are applicable to Risk Type 2 areas.

A. Narrative Effluent Standards

These areas must meet the following narrative effluent standards:

- Dischargers shall ensure that storm water discharges and authorized non-storm water discharges regulated by this General Permit do not contain a hazardous substance equal to or in excess of reportable quantities established in 40 C.F.R. §§ 117.3 and 302.4, unless a separate NPDES Permit has been issued to regulate those discharges.
- Dischargers shall minimize or prevent pollutants in storm water discharges and authorized non-storm water discharges through the use of structural or non-structural controls, structures, and management practices that achieve BAT for toxic and nonconventional pollutants and BCT for conventional pollutants.

B. Numeric Effluent Standards

These areas must meet the following numeric effluent standards:

- Numeric Action Levels:
 - pH – 6.5 to 8.5 units
 - Turbidity – 250 NTU

Additionally, discharges from Active Treatment Systems must meet the following:

- Numeric Effluent Limits:
 - Turbidity:
 - 10 NTU (for daily flow-weighted average); and
 - 20 NTU (for any single sample).

III SPECIFIC REQUIREMENTS

The following sections describe specific measures to be implemented for Risk Type 2 areas of the project. Tables have been provided for each measure described in the CGP Attachment A that is applicable to a Risk Type 2 area.

The first column of the table provides a measure identification number that corresponds to the applicable measure in the next column. The measures listed in the second column are required for a Risk Type 2 area.

The second column includes the substance of the Risk Type-specific requirements from the CGP.

The third column of the table describes whether this measure is applicable to the project.

The fourth column provides one or more BMP options that correspond to each required measure. These BMP Options(s) are references to the SDG&E/SCG Water Quality Construction Best Management Practices Manual (or "BMP Manual"). .

The fifth column of the table identifies the location within the SWPPP that contains the information applicable to the fourth column. The information in the fourth column is either a BMP Option or an inventory form.

Locations of the applicable measures and BMP Options are identified on the SWPPP Site Map located in Appendix III. The initial layout of the BMPs has been identified by the QSD as part of the preparation of the SWPPP. As site conditions change, it is the responsibility of the QSD to make all revisions necessary.

The QSD prepared the tables below as part of the preparation of this SWPPP. It is the responsibility of the QSP to review these tables during the course of the project and advise the QSD to update the SWPPP as applicable. In addition, a QSP Implementation Checklist has been provided in Appendix VII to document the updates as applicable.

A. Good Site Management Housekeeping

This section addresses good site management (i.e., "housekeeping") practices, including practices for:

1. Construction Materials
2. Waste Management
3. Vehicle Storage and Maintenance
4. Landscape Maintenance
5. Assessment of Potential Pollutant Sources
6. Air Deposition

Tables have been provided for each good housekeeping measure described in the following sections, with the exception of Assessment of Potential Pollutant Sources (Section 5) and Air Deposition (Section 6). Section 5 describes specific actions that **must** be taken to comply with the permit.

Each of the following measures is an element of Good Site Management “Housekeeping” as described in the CGP.

1. Good Site Management (“Housekeeping”) Measures for Construction Materials at a minimum, shall consist of the following:

Construction Materials Measure ID No.	Construction Materials Measure	Applicable to Project?		BMP Option (check applicable option(s))	Location in SWPPP
		Yes	No ***		
CM-a	Conduct an inventory of the products used and/or expected to be used and the end products that are produced and/or expected to be produced ¹ .	X		QSP must conduct an inventory	Appendix V
CM-b	Cover and berm loose stockpiled construction materials that are not actively being used (i.e. soil, spoils, aggregate, fly-ash, stucco, hydrated lime, etc.).	X		<input checked="" type="checkbox"/> BMP 1-08	Appendix VI
CM-c	Store chemicals in watertight containers (with appropriate secondary containment to prevent any spillage or leakage) or in a storage shed (completely enclosed).	X		<input checked="" type="checkbox"/> BMP 2-01 <input checked="" type="checkbox"/> BMP 2-02 <input checked="" type="checkbox"/> BMP 2-03 <input checked="" type="checkbox"/> BMP 2-04 <input checked="" type="checkbox"/> BMP 2-05 <input checked="" type="checkbox"/> BMP 2-06	Appendix VI
CM-d	Minimize exposure of construction materials to precipitation (not applicable to materials designed to be outdoors and exposed to the environment).	X		<input checked="" type="checkbox"/> BMP 2-01 <input checked="" type="checkbox"/> BMP 2-02 <input checked="" type="checkbox"/> BMP 2-03 <input checked="" type="checkbox"/> BMP 2-04 <input checked="" type="checkbox"/> BMP 2-05 <input checked="" type="checkbox"/> BMP 2-06 <input checked="" type="checkbox"/> BMP 2-07 <input checked="" type="checkbox"/> BMP 2-08	Appendix VI
CM-e	Implement BMPs to prevent the off-site tracking of loose construction and landscape materials.	X		<input checked="" type="checkbox"/> BMP 1-07	Appendix VI

¹ This does not include materials and equipment that are designed to be outdoors and exposed to environmental conditions (i.e. poles, equipment pads, cabinets, conductors, insulators, bricks, etc.).

*** If BMP is not applicable, explain why here.

2. Good Site Management (“Housekeeping”) Measures for Waste Management at a minimum, shall consist of the following:

Waste Management Measure ID No.	Waste Management Measure	Applicable to Project?		BMP Option (check applicable option(s))	Location in SWPPP
		Yes	No***		
WM-a	Prevent disposal of any rinse or wash waters or materials on impervious or pervious site surfaces or into the storm drain system.	X		<input checked="" type="checkbox"/> BMP 3-02 <input type="checkbox"/> BMP 3-03 <input checked="" type="checkbox"/> BMP 3-04 <input checked="" type="checkbox"/> BMP 3-05 <input checked="" type="checkbox"/> BMP 3-06 <input type="checkbox"/> BMP 3-07 <input type="checkbox"/> BMP 3-08 <input type="checkbox"/> BMP 3-09	Appendix VI
WM-b	Ensure the containment of sanitation facilities (e.g., portable toilets) to prevent discharges of pollutants to the storm water drainage system or receiving water.	X		<input checked="" type="checkbox"/> BMP 2-07	Appendix VI
WM-c	Clean or replace sanitation facilities and inspecting them regularly for leaks and spills.	X		<input checked="" type="checkbox"/> BMP 2-07	Appendix VI
WM-d	Cover waste disposal containers at the end of every business day and during a rain event.	X		<input checked="" type="checkbox"/> BMP 2-01 <input checked="" type="checkbox"/> BMP 2-02 <input checked="" type="checkbox"/> BMP 2-03 <input checked="" type="checkbox"/> BMP 2-04 <input checked="" type="checkbox"/> BMP 2-05 <input checked="" type="checkbox"/> BMP 2-06 <input checked="" type="checkbox"/> BMP 2-07 <input checked="" type="checkbox"/> BMP 2-08	Appendix VI
WM-e	Prevent discharges from waste disposal containers to the storm water drainage system or receiving water.	X		<input checked="" type="checkbox"/> BMP 2-01 <input checked="" type="checkbox"/> BMP 2-02 <input checked="" type="checkbox"/> BMP 2-03 <input checked="" type="checkbox"/> BMP 2-04 <input checked="" type="checkbox"/> BMP 2-05 <input checked="" type="checkbox"/> BMP 2-06 <input checked="" type="checkbox"/> BMP 2-07 <input checked="" type="checkbox"/> BMP 2-08	Appendix VI
WM-f	Contain and securely protect stockpiled waste material from wind and rain at all times unless actively being used.	X		<input checked="" type="checkbox"/> BMP 1-08	Appendix VI

2. Good Site Management (“Housekeeping”) Measures for Waste Management at a minimum, shall consist of the following:

Waste Management Measure ID No.	Waste Management Measure	Applicable to Project?		BMP Option (check applicable option(s))	Location in SWPPP
		Yes	No***		
WM-g	Implement procedures that effectively address hazardous and non-hazardous spills.	X		<input checked="" type="checkbox"/> BMP 2-03	Appendix VI
WM-h	Develop a spill response and implementation element of the SWPPP prior to commencement of construction activities. The SWPPP shall require that: <ul style="list-style-type: none"> • Equipment and materials for cleanup of spills shall be available on site and that spills and leaks shall be cleaned up immediately and disposed of properly; and • Appropriate spill response personnel are assigned and trained. 	X		<input checked="" type="checkbox"/> BMP 2-03	-Appendix VI. -For spill response personnel, see Appendix XIII. -For relevant training see Appendix XV.
WM-i	Ensure the containment of concrete washout areas and other washout areas that may contain additional pollutants so there is no discharge into the underlying soil and onto the surrounding areas.	X		<input checked="" type="checkbox"/> BMP 2-04	Appendix VI

***** If BMP is not applicable, explain here.**

4. Good Site Management (“Housekeeping”) Measures for Landscape Materials at a minimum, shall consist of the following:

Landscape Materials Measure ID No.	Landscape Materials Measure	Applicable to Project?		BMP Option (check applicable option(s))	Location in SWPPP
		Yes	No***		
LM-a	Contain stockpiled materials such as mulches and topsoil when they are not actively being used.	X		<input checked="" type="checkbox"/> BMP 1-08 <input checked="" type="checkbox"/> BMP 4-07 <input checked="" type="checkbox"/> BMP 4-02	Appendix VI
LM-b	Contain fertilizers and other landscape materials when they are not actively being used.	X		<input checked="" type="checkbox"/> BMP 1-08 <input checked="" type="checkbox"/> BMP 2-01 <input checked="" type="checkbox"/> BMP 2-02	Appendix VI
LM-c	Discontinuing the application of any erodible landscape material within 2 days before a forecasted rain event ² or during periods of precipitation.	X		<input type="checkbox"/> BMP 3-07 <input checked="" type="checkbox"/> BMP 2-02	Appendix VI
LM-d	Apply erodible landscape material at quantities and application rates according to manufacture recommendations or based on written specifications by knowledgeable and experienced field personnel.	X		<input type="checkbox"/> BMP 3-07 <input checked="" type="checkbox"/> BMP 2-02	Appendix VI
LM-e	Stacking erodible landscape material on pallets and covering or storing such materials when not being used or applied.	X		<input type="checkbox"/> BMP 3-07 <input checked="" type="checkbox"/> BMP 2-01 <input checked="" type="checkbox"/> BMP 2-02	Appendix VI

² Excerpt from CGP – 50% or greater chance of producing precipitation.

***** If BMP is not applicable, explain here.**

5. Good Housekeeping for Assessment of Potential Pollutant Sources

Pollutant sources will be dynamic over the life of the construction project due to the various phases of construction.

An assessment of construction materials that may be used and activities that will be performed during this project that may have the potential to contribute pollutants, other than sediment, to storm water runoff for the project is located in Appendix V. The QSP must review the list throughout the life of the project and update it accordingly. Appropriate revisions to the SWPPP based on any changes to the list shall be made by the QSD.

In addition, a history of leaks or spills is maintained in Appendix XIV.

6. Good Housekeeping for Control of Air Deposition

This project shall implement good housekeeping measures on the construction site related to Air Deposition:

Air Deposition Measure ID No.	Air Deposition Measure	Applicable to Project?		BMP Option (check applicable option(s))	Location in SWPPP
		Yes	No***		
AD-a	Control the air deposition of site materials and from site operations.	X		<input checked="" type="checkbox"/> BMP 4-08	Appendix VI

***** If BMP is not applicable, explain here.**

B. Non-Storm Water Management

All non-storm water discharges are required to be controlled. BMPs must be implemented for construction related activities that are potential sources of discharges other than storm water.

Implement the following measures to control all **Non-Storm Water Discharges** during construction:

Non-Storm Water Management Measure ID No.	Non-Storm Water Measure	Applicable to Project?		BMP Option (check applicable option(s))	Location in SWPPP
		Yes	No***		
NSWM-a	Implement measures to control all non-storm water discharges during construction.	X		<input type="checkbox"/> BMP 3-03 <input checked="" type="checkbox"/> BMP 3-02 <input checked="" type="checkbox"/> BMP 1-07	Appendix VI
NSWM-b	Wash vehicles in such a manner as to prevent non-storm water discharges to surface waters or MS4 drainage systems.		X	<input type="checkbox"/> BMP 3-03	Appendix VI
NSWM-c	Clean streets in such a manner as to prevent non-storm water discharges from reaching surface water or MS4 drainage systems.	X		<input checked="" type="checkbox"/> BMP 3-02 <input checked="" type="checkbox"/> BMP 1-07	Appendix VI

***** If BMP is not applicable, explain here.**

Washing of vehicles will not be conducted on the project site per SDG&E direction.

C. Erosion Control Measures

Erosion is the detachment of soil from existing landscapes by water or wind. Erosion is a natural process that can be accelerated by construction activities such as grading or trenching. For example, when a site is cleared or grubbed, protective vegetation is removed and the disturbed soil is directly exposed to wind and water. Erosion controls protect the surface and prevent the soil particles from being detached by rainfall or wind. BMPs for erosion control include soil stabilization.

Erosion Control measures, at a minimum, shall consist of the following:

Erosion Control Measure ID No.	Erosion Control Measure	Applicable to Project?		BMP Option (check applicable option(s))	Location in SWPPP
		Yes	No***		
ECM-a	Implement effective wind erosion control.	X		<input checked="" type="checkbox"/> BMP 4-08	Appendix VI
ECM-b	Provide effective soil cover for inactive ³ areas and all finished slopes and utility backfill.	X		<input checked="" type="checkbox"/> BMP 4-02 <input type="checkbox"/> BMP 4-03 <input checked="" type="checkbox"/> BMP 4-04 <input type="checkbox"/> BMP 4-05 <input type="checkbox"/> BMP 4-06 <input checked="" type="checkbox"/> BMP 4-07	Appendix VI
ECM-c	Limit the use of plastic materials when more sustainable, environmentally friendly alternatives exist. Where plastic materials are deemed necessary, the LRP shall consider the use of plastic materials resistant to solar degradation.	X		<input checked="" type="checkbox"/> BMP 4-07	Appendix VI

³ Excerpt from the CGP: Inactive areas of construction are areas of construction activity that have been disturbed and are not scheduled to be re-disturbed for at least 14 days.

***** If BMP is not applicable, explain here.**

D. Sediment Control Measures

Sediment particles (soil/dust) from construction activities can be transported to a different location by wind or water flow. Sediment controls are usually methods that trap the soil particles after they have detached and have moved by wind or water.

Sediment control measures, at a minimum, shall consist of the following:

Sediment Control Measure	Sediment Control Measure	Applicable to Project?		BMP Option (Check the applicable option(s))	Location in SWPPP
		Yes	No* If not applicable, explain below		
SC-a	Establish and maintain effective perimeter controls as needed, and implement effective BMPs for all construction entrances and exits to sufficiently control erosion and sediment discharges from the site.	X		<input checked="" type="checkbox"/> BMP 1-01 <input checked="" type="checkbox"/> BMP 1-02 <input checked="" type="checkbox"/> BMP 1-03 <input checked="" type="checkbox"/> BMP 1-04 <input type="checkbox"/> BMP 1-05 <input checked="" type="checkbox"/> BMP 1-06 <input checked="" type="checkbox"/> BMP 1-07 <input checked="" type="checkbox"/> BMP 1-08	Appendix VI
SC-b	On sites where sediment basins are to be used, at a minimum, design sediment basins according to the method provided in CASQA's Construction BMP Handbook.		X	N/A	Appendix VI
SC-c	Apply linear sediment controls along the toe of the slope, face of the slope, and at the grade breaks of exposed slopes to comply with sheet flow lengths ⁵ in accordance with Table 1 (See Table 1 below).	X		<input checked="" type="checkbox"/> BMP 1-02 <input checked="" type="checkbox"/> BMP 1-03	Appendix VI
SC-d	Ensure that construction activity traffic to and from the project is limited to entrances and exits that employ effective controls to prevent offsite tracking of sediment.	X		<input checked="" type="checkbox"/> BMP 1-07	Appendix VI
SC-e	Ensure that all storm drain inlets and perimeter controls, runoff control BMPs, and pollutant controls at entrances and exits (e.g. tire wash off locations) are maintained and protected from activities that reduce their effectiveness.	X		<input checked="" type="checkbox"/> BMP 1-06	Appendix VI

⁴ Active areas of construction are areas undergoing land surface disturbance. This includes construction activity during the preliminary stage, mass grading stage, streets and utilities stage, and the vertical construction stage.

⁵ Sheet flow length is the length that shallow, low velocity flow travels across a site.

Sediment Control Measure	Sediment Control Measure	Applicable to Project?		BMP Option (Check the applicable option(s))	Location in SWPPP
		Yes	No* If not applicable, explain below		
SC-f	Inspect all immediate access roads. At a minimum daily (when necessary) and prior to any rain event, the LRP shall remove any sediment or other construction activity-related materials that are deposited on the roads (by vacuuming or sweeping).	X		<input checked="" type="checkbox"/> BMP 1-07	Appendix VI

Excerpt from the CGP Attachment A:

Table 1 - Critical Slope/Sheet Flow Length Combinations

Slope Percentage	Sheet flow length not to exceed
0-25%	20 feet
25-50%	15 feet
Over 50%	10 feet

***** If BMP is not applicable, explain here.**

No sediment basins to be used.

E. Run-on and Run-off Controls

Run-on and Run-off Controls shall be effectively managed for all run-on/run-off associated with the site and all runoff that discharges off the site, through the following measures.

Run-on and Run-off Control Measures ID No.	Run-on and Run-off Controls	Applicable to Project?		Location in SWPPP
		Yes***	No***	
RRC-a	Effectively manage all run-on, all runoff within the site and all runoff that discharges off the site.	X		Appendix VI
RRC-b	Run-on from off site shall be directed away from all disturbed areas or shall collectively be in compliance with the effluent limitations in Attachment A of the CGP.	X		Appendix VI

***** If BMP is not applicable, explain here. If BMPs are required, describe the BMPs and the locations where they will be implemented.**

IV Inspection, Maintenance and Repair

The purpose of storm water inspections is to evaluate BMP effectiveness and implement repairs or design changes as soon as feasible.

Inspections, maintenance repair and sampling activities shall be conducted by the QSP or a trained individual directed by a QSP.

Daily Visual Inspections

Dischargers shall conduct visual inspections and observations daily during working hours. These inspections do not need to be recorded.

These visual inspections shall be discontinued in areas where construction activity is complete. If such an area does not meet the permit's final stabilization criteria at the end of construction activity, temporary and permanent stabilization BMPs shall be inspected in accordance with post-construction inspection requirements found in Appendix X, Section 2.

Rain Event Inspections

For each pre- and post-rain event inspection required, Risk Type 2 projects shall complete a site inspection form, located in Appendix IX. Prior to conducting a site inspection, obtain weather information at the following website: <http://www.srh.noaa.gov/forecast>) and attach the information to the inspection form.

A visual inspection must be conducted at least every 24-hour period during extended storm events to identify and record BMPs that need maintenance to operate effectively, that have failed, or that could fail to operate as intended.

Upon identifying failures or other shortcomings, as directed by the QSP, Risk Type 2 projects shall begin implementing repairs or design changes to BMPs within 72 hours of identification and complete the changes as soon as possible.

Inspection Information RequirementsThe inspection forms shall remain onsite with the SWPPP and at a minimum shall include:

- Inspection date and date the inspection report was written.
- Weather information, including presence or absence of precipitation, estimate of beginning of qualifying storm event, duration of event, time elapsed since last storm, and approximate amount of rainfall in inches.
- Site information, including stage of construction, activities completed, and approximate area of the site exposed.
- A description of any BMPs evaluated and any deficiencies noted.
- If the construction site is safely accessible during inclement weather, list the observations of all BMPs: erosion controls, sediment controls, chemical and waste controls, and non-storm water controls. Otherwise, list the results of visual inspections at all relevant outfalls, discharge points, downstream locations and any projected maintenance activities.
- Report the presence of noticeable odors or of any visible sheen on the surface of any discharges.

- Any corrective actions required, including any necessary changes to the SWPPP and the associated implementation dates.
- Photographs taken during the inspection, if any.
- Inspector's name, title, and signature.

Blank inspection forms are located in Appendix I. Completed site inspection forms shall be retained in Appendix IX.

Appendix VIII

C. Risk Type 3 Requirements

I RISK TYPE DETERMINATION

A risk Type Determination has been conducted for the Sycamore - Peñasquitos 230 kV Transmission Line Project and the following area within the project have been determined to be a **Risk Type 3**. The documentation for the Risk Type is located in Appendix IV.

Risk Type 3 Areas

Area	From	To
	GPS\Description	GPS\Description
Segment 7C: Costal Zone Boundary	32.89926°N, -117.20886°W	32.91185°N, -117.21662°W

II EFFLUENT STANDARDS

The following effluent standards are applicable to Risk Type 3 areas.

A. Narrative Effluent Standards

These areas must meet the following narrative effluent standards:

- Dischargers shall ensure that storm water discharges and authorized non-storm water discharges regulated by this General Permit do not contain a hazardous substance equal to or in excess of reportable quantities established in 40 C.F.R. §§ 117.3 and 302.4, unless a separate NPDES Permit has been issued to regulate those discharges.
- Dischargers shall minimize or prevent pollutants in storm water discharges and authorized non-storm water discharges through the use of structural or non-structural controls, structures, and management practices that achieve BAT for toxic and nonconventional pollutants and BCT for conventional pollutants.

B. Numeric Effluent Standards

These areas must meet the following numeric effluent standards:

- Numeric Action Levels:
 - pH – 6.5 to 8.5 units
 - Turbidity – 250 ntu

Additionally, discharges from Active Treatment Systems must meet the following:

- Numeric Effluent Limits:
 - Turbidity:
 - 10 ntu (for daily flow-weighted average); and
 - 20 ntu (for any single sample).

III SPECIFIC REQUIREMENTS

The following sections describe specific measures to be implemented for Risk Type 3 areas of the project. Tables have been provided for each measure described in the CGP Attachment A that is applicable to a Risk Type 3 area.

The first column of the table provides a measure identification number that corresponds to the applicable measure in the next column. The measures listed in the second column are required for a Risk Type 3 area.

The second column includes the substance of the Risk Type-specific requirements from the CGP.

The third column of the table describes whether this measure is applicable to the project.

The fourth column provides one or more BMP options that correspond to each required measure. These BMP Options(s) are references to the SDG&E/SCG Water Quality Construction Best Management Practices Manual (or "BMP Manual"). .

The fifth column of the table identifies the location within the SWPPP that contains the information applicable to the fourth column. The information in the fourth column is either a BMP Option or an inventory form.

Locations of the applicable measures and BMP Options are identified on the SWPPP Site Map located in Appendix III. The initial layout of the BMPs has been identified by the QSD as part of the preparation of the SWPPP. As site conditions change, it is the responsibility of the QSD to make all revisions necessary.

The QSD prepared the tables below as part of the preparation of this SWPPP. It is the responsibility of the QSP to review these tables during the course of the project and advise the QSD to update the SWPPP as applicable. In addition, a QSP Implementation Checklist has been provided in Appendix VII to document the updates as applicable.

A. Good Site Management Housekeeping

This section addresses good site management (i.e., "housekeeping") practices, including practices for:

1. Construction Materials
2. Waste Management
3. Vehicle Storage and Maintenance
4. Landscape Maintenance
5. Assessment of Potential Pollutant Sources
6. Air Deposition

Tables have been provided for each good housekeeping measure described in the following sections, with the exception of Assessment of Potential Pollutant Sources

(Section 5) and Air Deposition (Section 6). Section 5 describes specific actions that ***must*** be taken to comply with the permit.

Each of the following measures is an element of Good Site Management “Housekeeping” as described in the CGP.

1. Good Site Management (“Housekeeping”) Measures for Construction Materials at a minimum, shall consist of the following:

Construction Materials Measure ID No.	Construction Materials Measure	Applicable to Project?		BMP Option (check applicable option(s))	Location in SWPPP
		Yes	No ***		
CM-a	Conduct an inventory of the products used and/or expected to be used and the end products that are produced and/or expected to be produced ¹ .	X		QSP must conduct an inventory	Appendix V
CM-b	Cover and berm loose stockpiled construction materials that are not actively being used (i.e. soil, spoils, aggregate, fly-ash, stucco, hydrated lime, etc.).	X		<input checked="" type="checkbox"/> BMP 1-08	Appendix VI
CM-c	Store chemicals in watertight containers (with appropriate secondary containment to prevent any spillage or leakage) or in a storage shed (completely enclosed).	X		<input checked="" type="checkbox"/> BMP 2-01 <input checked="" type="checkbox"/> BMP 2-02 <input checked="" type="checkbox"/> BMP 2-03 <input checked="" type="checkbox"/> BMP 2-04 <input checked="" type="checkbox"/> BMP 2-05 <input checked="" type="checkbox"/> BMP 2-06	Appendix VI
CM-d	Minimize exposure of construction materials to precipitation (not applicable to materials designed to be outdoors and exposed to the environment).	X		<input checked="" type="checkbox"/> BMP 2-01 <input checked="" type="checkbox"/> BMP 2-02 <input checked="" type="checkbox"/> BMP 2-03 <input checked="" type="checkbox"/> BMP 2-04 <input checked="" type="checkbox"/> BMP 2-05 <input checked="" type="checkbox"/> BMP 2-06 <input checked="" type="checkbox"/> BMP 2-07 <input checked="" type="checkbox"/> BMP 2-08	Appendix VI
CM-e	Implement BMPs to prevent the off-site tracking of loose construction and landscape materials.	X		<input checked="" type="checkbox"/> BMP 1-07	Appendix VI

¹ This does not include materials and equipment that are designed to be outdoors and exposed to environmental conditions (i.e. poles, equipment pads, cabinets, conductors, insulators, bricks, etc.).

*** If BMP is not applicable, explain why here.

2. Good Site Management (“Housekeeping”) Measures for Waste Management at a minimum, shall consist of the following:

Waste Management Measure ID No.	Waste Management Measure	Applicable to Project?		BMP Option (check applicable option(s))	Location in SWPPP
		Yes	No***		
WM-a	Prevent disposal of any rinse or wash waters or materials on impervious or pervious site surfaces or into the storm drain system.	X		<input checked="" type="checkbox"/> BMP 3-02 <input type="checkbox"/> BMP 3-03 <input checked="" type="checkbox"/> BMP 3-04 <input checked="" type="checkbox"/> BMP 3-05 <input checked="" type="checkbox"/> BMP 3-06 <input type="checkbox"/> BMP 3-07 <input type="checkbox"/> BMP 3-08 <input checked="" type="checkbox"/> BMP 3-09	Appendix VI
WM-b	Ensure the containment of sanitation facilities (e.g., portable toilets) to prevent discharges of pollutants to the storm water drainage system or receiving water.	X		<input checked="" type="checkbox"/> BMP 2-07	Appendix VI
WM-c	Clean or replace sanitation facilities and inspecting them regularly for leaks and spills.	X		<input checked="" type="checkbox"/> BMP 2-07	Appendix VI
WM-d	Cover waste disposal containers at the end of every business day and during a rain event.	X		<input checked="" type="checkbox"/> BMP 2-01 <input checked="" type="checkbox"/> BMP 2-02 <input checked="" type="checkbox"/> BMP 2-03 <input checked="" type="checkbox"/> BMP 2-04 <input checked="" type="checkbox"/> BMP 2-05 <input checked="" type="checkbox"/> BMP 2-06 <input checked="" type="checkbox"/> BMP 2-07 <input checked="" type="checkbox"/> BMP 2-08	Appendix VI
WM-e	Prevent discharges from waste disposal containers to the storm water drainage system or receiving water.	X		<input checked="" type="checkbox"/> BMP 2-01 <input checked="" type="checkbox"/> BMP 2-02 <input checked="" type="checkbox"/> BMP 2-03 <input checked="" type="checkbox"/> BMP 2-04 <input checked="" type="checkbox"/> BMP 2-05 <input checked="" type="checkbox"/> BMP 2-06 <input checked="" type="checkbox"/> BMP 2-07 <input checked="" type="checkbox"/> BMP 2-08	Appendix VI
WM-f	Contain and securely protect stockpiled waste material from wind and rain at all times unless actively being used.			<input type="checkbox"/> BMP 1-08	Appendix VI

2. Good Site Management (“Housekeeping”) Measures for Waste Management at a minimum, shall consist of the following:

Waste Management Measure ID No.	Waste Management Measure	Applicable to Project?		BMP Option (check applicable option(s))	Location in SWPPP
		Yes	No***		
WM-g	Implement procedures that effectively address hazardous and non-hazardous spills.	X		<input checked="" type="checkbox"/> BMP 2-03	Appendix VI
WM-h	Develop a spill response and implementation element of the SWPPP prior to commencement of construction activities. The SWPPP shall require that: <ul style="list-style-type: none"> • Equipment and materials for cleanup of spills shall be available on site and that spills and leaks shall be cleaned up immediately and disposed of properly; and • Appropriate spill response personnel are assigned and trained. 	X		<input checked="" type="checkbox"/> BMP 2-03	-Appendix VI. -For spill response personnel, see Appendix XIII. -For relevant training see Appendix XV.
WM-i	Ensure the containment of concrete washout areas and other washout areas that may contain additional pollutants so there is no discharge into the underlying soil and onto the surrounding areas.	X		<input checked="" type="checkbox"/> BMP 2-04	Appendix VI

***** If BMP is not applicable, explain here.**

3. Good Site Management (“Housekeeping”) Measures for Vehicle Storage and Maintenance , at a minimum, shall consist of the following:

Vehicle Storage and Maintenance Measure ID No.	Vehicle Storage and Maintenance Measure	Applicable to Project?		BMP Option (check applicable option(s))	Location in SWPPP
		Yes	No***		
VSM-a	Prevent oil, grease, or fuel to leak in to the ground, storm drains or surface waters.	X		<input type="checkbox"/> BMP 3-03 <input checked="" type="checkbox"/> BMP 3-05	Appendix VI
VSM-b	Implement appropriate BMPs wherever equipment or vehicles are fueled, maintained or stored.	X		<input checked="" type="checkbox"/> BMP 2-03 <input checked="" type="checkbox"/> BMP 2-02 <input type="checkbox"/> BMP 3-03 <input checked="" type="checkbox"/> BMP 3-04	Appendix VI
VSM-c	Clean leaks immediately and disposing of leaked materials properly.	X		<input checked="" type="checkbox"/> BMP 2-03	Appendix VI

***** If BMP is not applicable, explain here.**

4. Good Site Management (“Housekeeping”) Measures for Landscape Materials at a minimum, shall consist of the following:

Landscape Materials Measure ID No.	Landscape Materials Measure	Applicable to Project?		BMP Option (check applicable option(s))	Location in SWPPP
		Yes	No***		
LM-a	Contain stockpiled materials such as mulches and topsoil when they are not actively being used.	X		<input checked="" type="checkbox"/> BMP 1-08 <input checked="" type="checkbox"/> BMP 4-07 <input checked="" type="checkbox"/> BMP 4-02	Appendix VI
LM-b	Contain fertilizers and other landscape materials when they are not actively being used.	X		<input checked="" type="checkbox"/> BMP 1-08 <input checked="" type="checkbox"/> BMP 2-01 <input checked="" type="checkbox"/> BMP 2-02	Appendix VI
LM-c	Discontinuing the application of any erodible landscape material within 2 days before a forecasted rain event ² or during periods of precipitation.	X		<input type="checkbox"/> BMP 3-07 <input checked="" type="checkbox"/> BMP 2-02	Appendix VI
LM-d	Apply erodible landscape material at quantities and application rates according to manufacture recommendations or based on written specifications by knowledgeable and experienced field personnel.	X		<input type="checkbox"/> BMP 3-07 <input checked="" type="checkbox"/> BMP 2-02	Appendix VI
LM-e	Stacking erodible landscape material on pallets and covering or storing such materials when not being used or applied.	X		<input type="checkbox"/> BMP 3-07 <input checked="" type="checkbox"/> BMP 2-01 <input checked="" type="checkbox"/> BMP 2-02	Appendix VI

² Excerpt from CGP – 50% or greater chance of producing precipitation.

*** If BMP is not applicable, explain here.

5. Good Housekeeping for Assessment of Potential Pollutant Sources

Pollutant sources will be dynamic over the life of the construction project due to the various phases of construction.

An assessment of construction materials that may be used and activities that will be performed during this project that may have the potential to contribute pollutants, other than sediment, to storm water runoff for the project is located in Appendix V. The QSP must review the list throughout the life of the project and update it accordingly. Appropriate revisions to the SWPPP based on any changes to the list shall be made by the QSD.

In addition, a history of leaks or spills is maintained in Appendix XIV.

6. Good Housekeeping for Control of Air Deposition

This project shall implement good housekeeping measures on the construction site related to Air Deposition:

Air Deposition Measure ID No.	Air Deposition Measure	Applicable to Project?		BMP Option (check applicable option(s))	Location in SWPPP
		Yes	No***		
AD-a	Control the air deposition of site materials and from site operations.	X		<input checked="" type="checkbox"/> BMP 4-08	Appendix VI

***** If BMP is not applicable, explain here.**

B. Non-Storm Water Management

All non-storm water discharges are required to be controlled. BMPs must be implemented for construction related activities that are potential sources of discharges other than storm water.

Implement the following measures to control all **Non-Storm Water Discharges** during construction:

Non-Storm Water Management Measure ID No.	Non-Storm Water Measure	Applicable to Project?		BMP Option (check applicable option(s))	Location in SWPPP
		Yes	No***		
NSWM-a	Implement measures to control all non-storm water discharges during construction.	X		<input type="checkbox"/> BMP 3-03 <input checked="" type="checkbox"/> BMP 3-02 <input checked="" type="checkbox"/> BMP 1-07	Appendix VI
NSWM-b	Wash vehicles in such a manner as to prevent non-storm water discharges to surface waters or MS4 drainage systems.		X	<input type="checkbox"/> BMP 3-03	Appendix VI
NSWM-c	Clean streets in such a manner as to prevent non-storm water discharges from reaching surface water or MS4 drainage systems.	X		<input checked="" type="checkbox"/> BMP 3-02 <input checked="" type="checkbox"/> BMP 1-07	Appendix VI

***** If BMP is not applicable, explain here.**

Washing of vehicles will not be performed on the project site per SDG&E policy.

C. Erosion Control Measures

Erosion is the detachment of soil from existing landscapes by water or wind. Erosion is a natural process that can be accelerated by construction activities such as grading or trenching. For example, when a site is cleared or grubbed, protective vegetation is removed and the disturbed soil is directly exposed to wind and water. Erosion controls protect the surface and prevent the soil particles from being detached by rainfall or wind. BMPs for erosion control include soil stabilization.

Erosion Control measures, at a minimum, shall consist of the following:

Erosion Control Measure ID No.	Erosion Control Measure	Applicable to Project?		BMP Option (check applicable option(s))	Location in SWPPP
		Yes	No***		
ECM-a	Implement effective wind erosion control.	X		<input checked="" type="checkbox"/> BMP 4-08	Appendix VI
ECM-b	Provide effective soil cover for inactive ³ areas and all finished slopes and utility backfill.	X		<input checked="" type="checkbox"/> BMP 4-02 <input type="checkbox"/> BMP 4-03 <input checked="" type="checkbox"/> BMP 4-04 <input type="checkbox"/> BMP 4-05 <input type="checkbox"/> BMP 4-06 <input checked="" type="checkbox"/> BMP 4-07	Appendix VI
ECM-c	Limit the use of plastic materials when more sustainable, environmentally friendly alternatives exist. Where plastic materials are deemed necessary, the LRP shall consider the use of plastic materials resistant to solar degradation.	X		<input checked="" type="checkbox"/> BMP 4-07	Appendix VI

³ Excerpt from the CGP: Inactive areas of construction are areas of construction activity that have been disturbed and are not scheduled to be re-disturbed for at least 14 days.

***** If BMP is not applicable, explain here.**

D. Sediment Control Measures

Sediment particles (soil/dust) from construction activities can be transported to a different location by wind or water flow. Sediment controls are usually methods that trap the soil particles after they have detached and have moved by wind or water.

Sediment control measures, at a minimum, shall consist of the following:

Sediment Control Measure	Sediment Control Measure	Applicable to Project?		BMP Option (Check the applicable option(s))	Location in SWPPP
		Yes	No* If not applicable, explain below		
SC-a	Establish and maintain effective perimeter controls as needed, and implement effective BMPs for all construction entrances and exits to sufficiently control erosion and sediment discharges from the site.	X		<input checked="" type="checkbox"/> BMP 1-01 <input checked="" type="checkbox"/> BMP 1-02 <input checked="" type="checkbox"/> BMP 1-03 <input checked="" type="checkbox"/> BMP 1-04 <input type="checkbox"/> BMP 1-05 <input checked="" type="checkbox"/> BMP 1-06 <input checked="" type="checkbox"/> BMP 1-07 <input checked="" type="checkbox"/> BMP 1-08	Appendix VI
SC-b	On sites where sediment basins are to be used, at a minimum, design sediment basins according to the method provided in CASQA's Construction BMP Handbook.		X	N/A	Appendix VI
SC-c	Apply linear sediment controls along the toe of the slope, face of the slope, and at the grade breaks of exposed slopes to comply with sheet flow lengths ⁵ in accordance with Table 1 (See Table 1 below).	X		<input checked="" type="checkbox"/> BMP 1-02 <input checked="" type="checkbox"/> BMP 1-03	Appendix VI
SC-d	Ensure that construction activity traffic to and from the project is limited to entrances and exits that employ effective controls to prevent offsite tracking of sediment.	X		<input checked="" type="checkbox"/> BMP 1-07	Appendix VI
SC-e	Ensure that all storm drain inlets and perimeter controls, runoff control BMPs, and pollutant controls at entrances and exits (e.g. tire washoff locations) are maintained and protected from activities that reduce their effectiveness.	X		<input checked="" type="checkbox"/> BMP 1-06	Appendix VI

⁴ Active areas of construction are areas undergoing land surface disturbance. This includes construction activity during the preliminary stage, mass grading stage, streets and utilities stage, and the vertical construction stage.

⁵ Sheet flow length is the length that shallow, low velocity flow travels across a site.

Sediment Control Measure	Sediment Control Measure	Applicable to Project?		BMP Option (Check the applicable option(s))	Location in SWPPP
		Yes	No* If not applicable, explain below		
SC-f	Inspect all immediate access roads. At a minimum daily (when necessary) and prior to any rain event, the LRP shall remove any sediment or other construction activity-related materials that are deposited on the roads (by vacuuming or sweeping).	X		<input checked="" type="checkbox"/> BMP 1-07	Appendix VI

Excerpt from the CGP Attachment A:

Table 1 - Critical Slope/Sheet Flow Length Combinations

Slope Percentage	Sheet flow length not to exceed
0-25%	20 feet
25-50%	15 feet
Over 50%	10 feet

*** If BMP is not applicable, explain here.

No sediment basins to be used.

E. Run-on and Run-off Controls

Run-on and Run-off Controls shall be effectively managed for all run-on/run-off associated with the site and all runoff that discharges off the site, through the following measures.

Run-on and Run-off Control Measures ID No.	Run-on and Run-off Controls	Applicable to Project?		Location in SWPPP
		Yes***	No***	
RRC-a	Effectively manage all run-on, all runoff within the site and all runoff that discharges off the site.	X		Appendix VI
RRC-b	Run-on from off site shall be directed away from all disturbed areas or shall collectively be in compliance with the effluent limitations in Attachment A of the CGP.	X		Appendix VI

***** If BMP is not applicable, explain here. If BMPs are required, describe the BMPs and the locations where they will be implemented.**

IV Inspection, Maintenance and Repair

The purpose of storm water inspections is to evaluate BMP effectiveness and implement repairs or design changes as soon as feasible.

Inspections, maintenance repair and sampling activities shall be conducted by the QSP or a trained individual directed by a QSP.

Daily Visual Inspections

Dischargers shall conduct visual inspections and observations daily during working hours. These inspections do not need to be recorded.

Rain Event Inspections

For each pre- and post-rain event inspection required, Risk Type 3 projects shall complete a site inspection form, located in Appendix IX. Prior to conducting a site inspection, obtain weather information at the following website: <http://www.srh.noaa.gov/forecast>) and attach the information to the inspection form.

A visual inspection must be conducted at least every 24-hour period during extended storm events to identify and record BMPs that need maintenance to operate effectively, that have failed, or that could fail to operate as intended.

Upon identifying failures or other shortcomings, as directed by the QSP, Risk Type 3 projects shall begin implementing repairs or design changes to BMPs within 72 hours of identification and complete the changes as soon as possible.

Inspection Information RequirementsThe inspection forms shall remain onsite with the SWPPP and at a minimum shall include:

- Inspection date and date the inspection report was written.
- Weather information, including presence or absence of precipitation, estimate of beginning of qualifying storm event, duration of event, time elapsed since last storm, and approximate amount of rainfall in inches.
- Site information, including stage of construction, activities completed, and approximate area of the site exposed.
- A description of any BMPs evaluated and any deficiencies noted.
- If the construction site is safely accessible during inclement weather, list the observations of all BMPs: erosion controls, sediment controls, chemical and waste controls, and non-storm water controls. Otherwise, list the results of visual inspections at all relevant outfalls, discharge points, downstream locations and any projected maintenance activities.
- Report the presence of noticeable odors or of any visible sheen on the surface of any discharges.
- Any corrective actions required, including any necessary changes to the SWPPP and the associated implementation dates.
- Photographs taken during the inspection, if any.
- Inspector's name, title, and signature.

Blank inspection forms are located in Appendix I. Completed site inspection forms shall be retained in Appendix IX.

APPENDIX IX
SITE INSPECTION RECORDS

APPENDIX X
MONITORING AND REPORTING PLAN

APPENDIX X CONSTRUCTION SITE MONITORING AND REPORTING PROGRAM (M&RP) FOR RISK TYPE 1 PROJECT AREAS

1. OVERVIEW

This appendix contains the Construction Site Monitoring & Reporting Program (M&RP) and includes the required monitoring procedures and instructions, location maps, forms and checklists.

The following areas within the project limits are considered Risk Type 1:

Area	From	To
	GPS\Description	GPS\Description
Segment 1: Sycamore Canyon Substation to MCAS Miramar Boundary	32.91733 °N, -117.03073°W	32.91983°N, -117.03223°W
Segment 2: MCAS Miramar Boundary to P5; including staging yards Stowe and Stonebridge	32.91983°N, -117.03223°W	32.92250°N, -117.04244°W
Segment 3: P5 to 1-15 Bridge	32.92250°N, -117.04244°W	32.89347°N, -117.11358°W
Segment 4: 1-15 Bridge Crossing	32.89347°N, -117.11358°W	32.89361°N, -117.11801°W
Segment 5: 1-15 to Carroll Canyon; including staging yards Site 1A, Site 1B, Site 2, Site 3, Shire Property (Sites 4A-4C) and Driving Range (Site 5)	32.89361°N, -117.11801°W	32.88984°N, -117.20303°W
Segment 8: Costal Zone Boundary North End to Peñasquitos Substation	32.91185°N, -117.21662°W	32.91825°N, -117.21923°W

Type 1 areas are required to conduct:

- Visual Inspections; and
- Non-Visible Pollutant Monitoring.

The Monitoring and Reporting Program (M&RP) shall be:

- Prepared prior to the start of construction; and
- Implemented immediately at the start of construction and until construction activity is complete and the site is stabilized.

Implementation of this M&RP shall be at the appropriate level to protect water quality at all times throughout the life of the project.

The M&RP shall be revised when:

- Site conditions or construction activities change such that a change in monitoring is required to comply with the requirements and intent of the Construction General Permit (CGP);

- The Regional Water Quality Control Board requires the discharger to revise its M&RP based on its review of the document (revisions shall be submitted via postal mail or electronic e-mail); or
- The Regional Water Quality Control Board requires additional monitoring and reporting program requirements including sampling and analysis of discharges to CWA § 303(d)-listed water bodies, where these additional requirements are consistent with the overall monitoring effort in the receiving waters.

2 VISUAL MONITORING (INSPECTION) REQUIREMENTS

The visual observations (inspections) described in this M&RP are separate from the site inspections described in Appendix VIII of this SWPPP.

Daily inspections, rain event and post-construction inspections shall be conducted as described below.

- Daily visual inspections:
 - Shall be conducted by trained personnel (record the names and contact information of the assigned inspection personnel in Appendix XIII);
 - Shall be conducted:
 - During working hours;
 - In conjunction with other daily activities; and
 - In areas where active construction is occurring.
 - Shall be conducted to verify that appropriate BMPs for storm water and non-storm water are being implemented and in place in areas where active construction is occurring (including staging areas).
 - Land areas disturbed during construction are returned to preconstruction conditions or an equivalent protection is used at the end of each workday to eliminate or minimize erosion and the possible discharge of sediment or other pollutants during a rain event.
 - May be discontinued in non-active construction areas where:
 - Soil-disturbing activities are completed; and
 - Final stabilization is achieved (e.g., paving is completed, substructures are installed, vegetation meets minimum cover for final stabilization, or other stabilization requirements are met).
 - Must be logged with the following information retained in Appendix XI.G:
 - Date and time of the inspection; and
 - Name of the person who conducted the inspection.
- Rain event inspections:
 - Shall be conducted by trained personnel (record the names and contact information of the assigned inspection personnel in Appendix XIII);
 - Shall be conducted in areas where active construction is occurring:
 - 48 hours prior to anticipated storm events;
 - For each 24-hour period during extended working storm events

- (during normal working hours); and
 - After actual storm events.
 - Shall be conducted to:
 - Identify areas contributing to a discharge of storm water associated with construction activities;
 - **Pre-storm:** Ensure that BMPs are properly installed and maintained; and
 - **Post-storm:** Ensure that BMPs have functioned adequately.
 - Photographs shall be:
 - Taken during inspections before, during and after storm events; and
 - Submitted through the SWRCB's SMARTS website once every three rain events.
 - May be discontinued in non-active construction areas where:
 - Soil-disturbing activities are completed; and
 - Final stabilization is achieved (e.g., paving is completed, substructures are installed, vegetation meets minimum cover for final stabilization, or other stabilization requirements are met).
 - Must be logged with the following information retained in Appendix XI.G:
 - Date and time of the inspection; and
 - Name of the person who conducted the inspection.
- Post-construction (i.e., where temporary and permanent stabilization BMPs are required after active construction is complete) inspections:
 - Are required where temporary and permanent stabilization BMPs are required after active construction is complete;
 - Shall be conducted by trained personnel (record the names and contact information of the assigned inspection personnel in Appendix XIII);
 - Inspections shall:
 - Ensure that BMPs are adequate and maintained; and
 - Continue until adequate permanent stabilization is established and, in vegetated areas, until minimum vegetative coverage is established in accordance with the CGP.
 - Non-rain event inspections:
 - Shall be conducted at least once per calendar month;
 - Where maintenance or repair of BMPs is required, the QSP shall begin implementing repairs or design changes to the BMPs within 72 hours of identification and complete the changes as soon as possible;
 - Log the following information (and retain it in Appendix XI.G):
 - ◆ Date and time of the inspection; and
 - ◆ Name of the person who conducted the inspection
 - Rain event inspections:

- Shall be conducted prior to and after anticipated storm events and during each 24-hour period during extended storm events;
 - Where maintenance or repair of BMPs is required, the QSP shall begin implementing repairs or design changes to the BMPs within 72 hours of identification and complete the changes as soon as possible;
 - Complete the Visual Observation form provided in Appendix XI.I during the inspection and retain it in Appendix XI.G):
 - Photographs shall be:
 - ◆ Taken during inspections before, during and after storm events;
 - ◆ Submitted through the SWRCB's SMARTS website once every three rain events.
 - Rain gauge readings shall be recorded from the closest rain gauge with publically available data
- A blank Visual Observation form is provided in Appendix XI.I. The QSP must complete these forms during the visual observation and insert a completed copy in Appendix XI.G.

Inspection Exemptions

Inspections are not required to be conducted under the following conditions:

- During dangerous weather conditions such as flooding and electrical storms.
- Outside of scheduled site business hours.
- When access to the site is unsafe due to storm events.

If a required inspection is not conducted due to these exceptions, an explanation shall be included in the SWPPP (Appendix XI.G) and in the Annual Report documenting why the inspection was not conducted.

3. WATER QUALITY SAMPLING AND ANALYSIS

Sampling and analysis is required for site effluents.

This Project area is a Risk Type 1. The CGP requires samples of the following effluents:

- Non-visible pollutant discharges, including:
 - Any parameters (if applicable) indicating the presence of pollutants identified in the list of potential pollutant sources listed in Appendix V;
 - The discharge of pollutants to surface waters that would not be visually detectable in storm water from a spill or during discharges resulting from a breach, malfunction, failure and/or leak of any BMP. Failure to implement BMPs may also require sample collection; and
 - A sample of stormwater that hasn't come in contact with the disturbed soil

or the materials stored or used on-site (uncontaminated sample).

A. Effluent Monitoring Requirements

1. Non-Visible Pollutant Sampling and Analysis

Potential Pollutant Sources

Some pollutants may be discharged to surface waters that would not be visually detectable in storm water. Sampling for these pollutants is only required when:

- The discharger believes pollutants associated with construction activities have the potential to be discharged with storm water runoff due to a spill or in the event there was a breach, malfunction, failure and/or leak of any BMP. Also, failure to implement BMPs may require sample collection.

Storm water monitoring will be performed in conjunction with storm event visual inspections that are required under the CGP. The following inspection forms shall be completed:

- For non-storm water: Visual Observation (Inspection) form for Non-Storm Water Discharges (Blank Form in Appendix I / Completed Form in Appendix XI.G).
- Sampling Event Worksheet (Blank Form in Appendix I / Completed Form in Appendix XI.B)

Construction Materials

A list of the project potential pollutants is located in Appendix V. The list of potential pollutants generated includes all pollutants that would be non-visible in stormwater runoff that are known or should be known to occur on the construction site. These “non-visible” pollutants are listed below. Non-visible pollutants require monitoring when there is a failure to implement a BMP or in the event there is a spill, breach, malfunction, failure and/or leakage observed during a visual inspection which could result in the discharge of these pollutants to surface waters that would not be visually detectable in storm water. Following is the list of pollutants:

- None

Based on the pollutants identified above, the following indicator parameters will be analyzed, as applicable, to assess if pollutants are potentially being conveyed from the site by storm water:

- None

Sampling and Analysis

- General - Grab samples shall be collected as follows:
 - Water samples shall be large enough to characterize the site conditions.
 - Samples shall be collected at all discharge locations that can be safely accessed.

- Locations
 - **Discharge points** – Samples shall be collected in areas associated with the pollutants identified above. Samples shall be collected down-gradient of the area(s) affected by any breach, malfunction, leakage, or spill observed during a visual inspection which could result in the discharge of pollutants to surface waters that would not be visually detectable in storm water. Sample locations where samples for unplanned discharges are taken will be added to Appendix XI.I.
 - **Uncontaminated Sample** – A sufficiently large sample of storm water shall be collected that has not come in contact with the disturbed soil or the materials stored or used on-site (uncontaminated sample) for comparison with the discharge sample. This sample location(s) is identified and described in Appendix XI.I.

- Frequency
 - Samples shall be collected during the first two hours of discharge from rain events that occur during business hours and which generate runoff.

- Parameters
 - Samples shall be analyzed for:
 - Not applicable
 - Dischargers shall modify their M&RP to address any additional parameters in accordance with any updated SWPPP pollutant source assessment.

- Sampling and Analysis
 - Section 4 and 5 (M&RP) contains the details of the sampling and analysis requirements for the applicable parameters.

- Reporting
 - All storm event sampling results from field tests (e.g., pH) shall be submitted to the SWRCB no later than 10 days after the conclusion of the storm event.
 - All storm event sampling results from laboratory tests (e.g., BOD) shall be retained in the SWPPP and submitted to the SWRCB in the annual report.

- Records

- Retain all field and/or analytical data in the SWPPP document. Generally all sampling and analysis related records are required to be retained for a minimum of three years. See M&RP Section 12 for record retention requirements.

B. Sampling Collection Exemptions

Samples are not required to be collected under the following conditions:

- During dangerous weather conditions such as flooding and electrical storms.
- Outside of scheduled site business hours.
- When access to the site is unsafe due to storm events.

If a required sample is not collected due to these exceptions, an explanation shall be included in the SWPPP (Appendix XI.G) and in the Annual Report documenting why the sampling was not conducted.

4. EFFLUENT WATER SAMPLE COLLECTION AND HANDLING INSTRUCTIONS

This section describes the instructions for sample collection and handling and includes:

- Detailed procedures for sample collection, storage, preservation, and shipping to the testing lab to assure that consistent quality control and quality assurance is maintained.
- An example Chain of Custody form to be used when handling and shipping samples.
- Identification of the analytical methods and related method detection limits (if applicable) for each parameter.

A. General Requirements

- Ensure that water samples are large enough to characterize the site conditions.
- Sampling and sample preservation shall be conducted in accordance with the current edition of "Standard Methods for the Examination of Water and Wastewater" (American Public Health Association).
- All monitoring instruments and equipment (including a discharger's own field instruments for measuring pH and turbidity) should be calibrated and maintained in accordance with manufacturers' specifications to ensure accurate measurements.
- All laboratory analyses shall be conducted according to test procedures under 40 CFR Part 136, unless other test procedures have been specified in this General Permit or by the Regional Water Board. With the exception of field analysis conducted by the discharger for turbidity and pH, all analyses should be sent to and conducted at a laboratory certified for such analyses by the State Department of Health Services.

- The discharger can conduct their own field analysis of pH and may conduct their own field analysis of turbidity if the discharger has sufficient capability (qualified and trained employees, properly calibrated and maintained field instruments, etc.) to adequately perform the field analysis.

Specific procedures are described below for parameters that are analyzed in the field and for parameters that are analyzed in a certified laboratory.

1. For Parameters Analyzed in the Field

pH:

- Sampling and Analyses:
 - Effluent and receiving water sample locations are identified in Appendix XI.I.
 - Field meters will be calibrated, maintained, and operated by trained staff according to the manufacturer's specifications, and calibration records will be stored in Appendix XI.B
 - Sampling and analysis for this parameter shall be conducted on-site by trained personnel with a portable field instrument in accordance with the instrument's instructions.
 - Sampling shall be conducted also in accordance with the field QA/QC document in Appendix XI.J.
 - Section 5 and Table 1 provide the Test Method, Protocol, Minimum Detection Limit, Reporting Units and NALs.

2. For Parameters Analyzed in a Laboratory

General: The laboratory will provide properly cleaned and preserved (if applicable) sampling containers (bottles) for the samples, and labels on the sample bottles. The sample bottle labels will identify the analysis to be performed and any preservative contained in the bottles, and provide room for recording the sample location and time and date of collection. The laboratory will also provide chain-of-custody forms. An example Chain of Custody form is located in Appendix I.

Personnel shall be designated and trained to collect, maintain, and ship samples in accordance with the Surface Water Ambient Monitoring Program's (SWAMP) 2008 Quality Assurance Program Plan (QAPrP). These personnel are identified in Appendix XIII. See Section 4.h.xii on page 41 of Attachment A of the CGP for additional information regarding SWAMP and QAPrP.

Other Parameters (when applicable):

- Sampling:
 - Collect samples during the first two hours of discharge from rain events that occur during business hours and which generate

- runoff. For non-visible pollutants, collect 3 samples per day rain event.
- Collect a sample of storm water that has not come in contact with the disturbed soil or the materials stored or used on-site (uncontaminated sample) for comparison with the discharge sample.
 - Effluent sample locations are identified in Appendix XI.I.
 - Sampling shall be conducted by trained personnel in accordance with the field QA/QC document in Appendix XI.J.
 - Samples shall be collected only in containers provided by the laboratory to which they will be sent.
 - Samples will be preserved in accordance with Table 2.
 - Samples shall be shipped using a using a method so that the laboratory receives them the same day or no later than 48 hours from their physical sampling (unless otherwise required by the laboratory).
- Analysis:
 - The QSP shall compare the uncontaminated sample to the samples of discharge using field analysis or through laboratory analysis.
 - Section 5 and Table 2 provides the test method, minimum sample volume, sampling container, preservative and holding time for the expected parameters.
 - If these analyses are required, samples will be sent to the laboratory identified in Appendix XI.H.

Table 1 - Testing methods, detection limits, reporting units and applicable NALs for pH and Turbidity (from Attachment A of the CGP).

Parameter	Test Method / Protocol	Discharge Type	Min. Detection Limit	Reporting Units
pH	Field test with calibrated portable instrument	Not applicable to Risk Type 1 discharges	0.2	pH

¹ ASTM, 1999, Standard Test Method for Determining Sediment Concentration in Water Samples: American Society of Testing and Materials, D 3977-97, Vol. 11.02, pp. 389-394.

Table 2 – Applicable Sample Collection Information for Parameters to be Analyzed at a Certified Laboratory

Analyte	EPA Analytical Method Number	Minimum Sample Volume ³	Sampling Container	Preservative ⁴	Holding Time

³Minimum sample volume recommended. Specific volume requirements will vary by laboratory and must be verified with the laboratory when bottles are ordered.

⁴Do not pre-rinse or overfill sample containers that contain preservative.

⁵All samples must be kept chilled to 4°C (keep samples on ice for delivery to analytical laboratory)

5. ANALYTICAL AND MONITORING METHODS

A. Effluent Sampling Methods

Effluent sampling is not required for risk Type 1 projects.

Evaluation of Results

No pH NAL has been established for Type 1 projects. Calculate the daily average pH results. If the daily average sample result is not within the range of 6.5 to 8.5, immediately contact the Company representative.

B. Non-Visible Pollutants

Refer to Table 2 in Section 4 above for analytical methods for non-visible pollutants.

Evaluation of Results

The Water Quality Control Plan for the San Diego Region ("Basin Plan") provides water quality objectives for some of the analytes that will be monitored. While these do not constitute a discharge standard or limit, these water quality objectives will be used as decision making benchmark standards. Where such standards are not available through the Basin Plan, benchmark standards set forth by other agencies will be used for decision making purposes.

Table 3 – Benchmarks for Review of Non-Visible Pollutants

Benchmark Criteria for Decision Making		
Analyte	Benchmark Concentration	Reference

*United States Environmental Protection Agency Multi-Sector Industrial Permit

6. NAL EXCEEDANCE REPORTS

This is a Risk Type 1 project area and, therefore, this section does not apply.

7. COMPLIANCE STORM EVENT EXEMPTION

This is a Risk Type 1 project area and, therefore, this section does not apply.

8. WATERSHED MONITORING OPTION

This is a Risk Type 1 project area and, therefore, this section does not apply.

9. PARTICLE SIZE ANALYSIS FOR PROJECT RISK JUSTIFICATION

This Project is not utilizing a sediment basin and/or justifying an alternative project risk.

10. BIOASSESSMENT

This is a Risk Type 1 project area and, therefore, this section does not apply.

11. RECORDS

The following records of all storm water monitoring information and copies of all reports (including Annual Reports) shall be retained for a period of at least three years. All records shall be retained on-site while construction is ongoing. These records include:

- The date, place, time of facility inspections, sampling, visual observation (inspections), and/or measurements, including precipitation.
- The individual(s) who performed the facility inspections, sampling, visual observation (inspections), and or measurements.
- The date and approximate time of analyses.
- The individual(s) who performed the analyses.

- A summary of all analytical results from the last three years, the method detection limits and reporting units, the analytical techniques or methods used, and the chain of custody forms.
- Rain gauge readings from site inspections.
- Quality assurance/quality control records and results.
- Non-storm water discharge inspections and visual observation (inspections) and storm water discharge visual observation records.
- Visual observation and sample collection exception records.
- The records of any corrective actions and follow-up activities that resulted from analytical results, visual observation (inspections), or inspections.

APPENDIX XX.I - M&RP – Inspection and Sampling Locations

Ref#	Name	Location		Sample Parameters	Sample Containers Required	
		Description	GPS Coordinates		Yes	No

Sample Location Reference Abbreviations:
Observations: **VQRE** (Visual Observations for a QRE); **VNSW** (Visual Observations for Non-Stormwater);
Sampling: **SNSW** (Sampling for Non-Stormwater); **SNVP** (Sampling for Non-Visually Detectible Pollutants; **SUC** (Sampling of Uncontaminated Sample Location); **SATS** (Sampling of ATS; **SRO** (Sampling of Run-on)
Identify sample locations on the Site Map

APPENDIX X CONSTRUCTION SITE MONITORING AND REPORTING PROGRAM (M&RP) FOR RISK TYPE 2 PROJECT AREAS

1. OVERVIEW

This appendix contains the Construction Site Monitoring & Reporting Program (M&RP) and includes the required monitoring procedures and instructions, location maps, forms and checklists.

The following area within the project limits are considered Risk Type 2:

Area	From	To
	GPS\Description	GPS\Description
Segment 6C: Carroll Canyon to Coastal Zone Boundary South End	32.88984°N, -117.20303°W	32.89926°N, -117.20886°W

Risk Type 2 areas are required to conduct:

- Visual Inspections;
- Storm Water Effluent Monitoring; and
- Non-Visible Pollutant Monitoring.

The Monitoring and Reporting Program (M&RP) shall be:

- Prepared prior to the start of construction; and
- Implemented immediately at the start of construction and until construction activity is complete and the site is stabilized.

Implementation of this M&RP shall be at the appropriate level to protect water quality at all times throughout the life of the project.

The M&RP shall be revised when:

- Site conditions or construction activities change such that a change in monitoring is required to comply with the requirements and intent of the Construction General Permit (CGP);
- The Regional Water Quality Control Board requires the discharger to revise its M&RP based on its review of the document (revisions shall be submitted via postal mail or electronic e-mail); or
- The Regional Water Quality Control Board requires additional monitoring and reporting program requirements including sampling and analysis of discharges to CWA § 303(d)-listed water bodies, where these additional requirements are consistent with the overall monitoring effort in the receiving waters.

Type 2 areas are also subject to Numeric Action Levels (NALs). When any of these NALs are not met, specific actions are required to be taken. The NAL requirements are described below.

2. VISUAL MONITORING (INSPECTION) REQUIREMENTS

The visual observations (inspections) described in this M&RP are specific to sampling events and do not serve the same purpose as the site inspections described in Appendix VIII of this SWPPP.

Daily inspections, rain event and post-construction inspections shall be conducted as described below.

- Daily visual inspections:
 - Shall be conducted by trained personnel (record the names and contact information of the assigned inspection personnel in Appendix XIII);
 - Shall be conducted:
 - During working hours;
 - In conjunction with other daily activities; and
 - In areas where active construction is occurring.
 - Shall be conducted to verify that appropriate BMPs for storm water and non-storm water are being implemented and in place in areas where active construction is occurring (including staging areas).
 - May be discontinued in non-active construction areas where:
 - Soil-disturbing activities are completed; and
 - Final stabilization is achieved (e.g., paving is completed, substructures are installed, vegetation meets minimum cover for final stabilization, or other stabilization requirements are met).
 - Must be logged with the following information retained in Appendix XI.G:
 - Date and time of the inspection; and
 - Name of the person who conducted the inspection.
- Rain event inspections:
 - Shall be conducted by trained personnel (record the names and contact information of the assigned inspection personnel in Appendix XIII);
 - Shall be conducted in areas where active construction is occurring:
 - Prior to anticipated storm events;
 - For each 48-hour period during extended working storm events (during normal working hours); and
 - After actual storm events.
 - Shall be conducted to:
 - Identify areas contributing to a discharge of storm water associated with construction activities;
 - **Pre-storm:** Ensure that BMPs are properly installed and maintained; and
 - **Post-storm:** Ensure that BMPs have functioned adequately.
 - Photographs shall be:
 - Taken during inspections before, during and after storm events; and
 - Submitted through the SWRCB's SMARTS website once every

- three rain events.
- May be discontinued in non-active construction areas where:
 - Soil-disturbing activities are completed; and
 - Final stabilization is achieved (e.g., paving is completed, substructures are installed, vegetation meets minimum cover for final stabilization, or other stabilization requirements are met).
- Rain gauges:
 - If possible, a rain gauge shall be installed on-site at an accessible and secure location;
 - Readings from a rain gauge shall be made during all rain storm event inspections;
 - Rain gauge readings shall be obtained from the closest rain gauge with publically available data when:
 - ◆ Readings from the on-site gauge (if present) are unavailable; or
 - ◆ No on-site rain gauge is present.
- Must be logged with the following information retained in Appendix XI.G:
 - Date and time of the inspection; and
 - Name of the person who conducted the inspection.
- Post-construction (i.e., where temporary and permanent stabilization BMPs are required after active construction is complete) inspections:
 - Are required where temporary and permanent stabilization BMPs are required after active construction is complete;
 - Shall be conducted by trained personnel (record the names and contact information of the assigned inspection personnel in Appendix XIII);
 - Inspections shall:
 - Ensure that BMPs are adequate and maintained; and
 - Continue until adequate permanent stabilization is established and, in vegetated areas, until minimum vegetative coverage is established in accordance with the CGP.
 - Non-rain event inspections:
 - Shall be conducted once per week during the rainy season and once every two weeks during the non-rainy season;
 - Where maintenance or repair of BMPs is required, the QSP shall begin implementing repairs or design changes to the BMPs within 72 hours of identification and complete the changes as soon as possible;
 - Log the following information (and retain it in Appendix XI.G):
 - ◆ Date and time of the inspection; and
 - ◆ Name of the person who conducted the inspection
 - Rain event inspections:
 - Shall be conducted prior to and after anticipated storm events and during each 24-hour period during extended storm events;

- Where maintenance or repair of BMPs is required, the QSP shall begin implementing repairs or design changes to the BMPs within 72 hours of identification and complete the changes as soon as possible;
 - Complete the Visual Observation form provided in Appendix XI.I during the inspection and retain it in Appendix XI.G);
 - Photographs shall be:
 - ◆ Taken during inspections before, during and after storm events;
 - ◆ Submitted through the SWRCB's SMARTS website once every three rain events.
 - Rain gauge readings shall be recorded from the closest rain gauge with publically available data
-
- A blank Visual Observation form is provided in Appendix XI.I. The QSP must complete these forms during the visual observation and insert a completed copy in Appendix XI.G.

Inspection Exemptions

Inspections are not required to be conducted under the following conditions:

- During dangerous weather conditions such as flooding and electrical storms.
- Outside of scheduled site business hours.
- When access to the site is unsafe due to storm events.

If a required inspection is not conducted due to these exceptions, an explanation shall be included in the SWPPP (Appendix XI.G) and in the Annual Report documenting why the inspection was not conducted.

3. WATER QUALITY SAMPLING AND ANALYSIS

Sampling and analysis is required for site effluents.

This Project area is a Risk Type 2. The CGP requires samples of the following effluents:

- Storm water, including discharges from stored or contained storm water and from Active Treatment Systems when they are utilized;
- Non-storm water and authorized non-storm water discharges; and
- Non-visible pollutant discharges, including:
 - Any parameters (if applicable) indicating the presence of pollutants identified in the list of potential pollutant sources listed in Appendix V;
 - The discharge of pollutants to surface waters that would not be visually detectable in storm water from a spill or during discharges resulting from a breach, malfunction, failure and/or leak of any BMP. Failure to implement BMPs may also require sample collection; and
 - A sample of stormwater that hasn't come in contact with the disturbed soil or the materials stored or used on-site (uncontaminated sample).

A. Effluent Monitoring Requirements

1. Storm Water Sampling and Analysis

- General - Storm water grab samples shall be collected as follows:
 - The storm water grab sample(s) obtained shall **be representative of the flow and characteristics** of the discharge.
 - Sampling and analysis of storm water discharges shall be conducted to **characterize discharges associated with construction activity** from the **entire project disturbed area**.
- Locations
 - **Discharge points** - Samples shall be collected from sampling locations characterizing discharges associated with activity from the project's active areas of construction. The sample locations are described in Appendix XI.I.
 - **Contained storm water** – Samples shall be collected from stored or contained storm water (i.e., subsequent to a storm event producing precipitation of ½" or more at the time of discharge). The sample locations are described in Appendix XI.I.
 - **Run-on from surrounding areas** – Samples may be collected and reported from run-on if there is reason to believe run-on may contribute to an exceedance of Numeric Action Levels. The sample locations are described in Appendix XI.I.
 - **Active Treatment System (ATS)** – When an ATS is used on the project, effluent samples and measurements shall be obtained from the discharge pipe or another location representative of the nature of the discharge. ATS is not applicable to this project.
- Frequency
 - Non-contained storm water:
 - At minimum, 3 samples per day of discharge shall be collected.
 - Contained or stored storm water:
 - Grab samples shall be collected daily of stored or contained storm water that are from discharges subsequent to a rain event (producing precipitation of ½ inch or more at the time of discharge).
- Parameters
 - Samples shall be analyzed for:
 - pH;
 - Turbidity; and
 - The following additional parameters for which monitoring is required by the RWQCB:
 - ◆ None

- Sampling and Analysis
 - Section 4 and 5 (M&RP) contains the details of the sampling and analysis requirements for the applicable parameters.
- Reporting
 - In the event any effluent sample exceeds an applicable NAL, the LRP shall electronically submit all sampling results from the field tests for that storm event to the State Water Resources Control Board (SWRCB) no later than 10 days after the conclusion of the storm event.
 - NAL Exceedances - The Regional Boards have the authority to require the submittal of an NAL Exceedance Report. If a report is required, see M&RP Section 6 for further details.
- Records
 - Generally all sampling and analysis related records are required to be retained for a minimum of three years. See M&RP Section 11 for record retention requirements.

2. Non-Visible Pollutant Sampling and Analysis

Potential Pollutant Sources

Some pollutants may be discharged to surface waters that would not be visually detectable in storm water. Sampling for these pollutants is only required when:

- The discharger believes pollutants associated with construction activities have the potential to be discharged with storm water runoff due to a spill or in the event there was a breach, malfunction, failure and/or leak of any BMP. Also, failure to implement BMPs may require sample collection.

Storm water monitoring will be performed in conjunction with storm event visual inspections that are required under the CGP. The following inspection forms shall be completed:

- For non-storm water: Visual Observation (Inspection) form for Non-Storm Water Discharges (Blank Form in Appendix I / Completed Form in Appendix XI.G).
- Sampling Event Worksheet (Blank Form in Appendix I / Completed Form in Appendix XI.B)

Construction Materials

A list of the project potential pollutants is located in Appendix V. The list of potential pollutants generated includes all pollutants that would be non-visible in stormwater runoff that are known or should be known to occur on the construction site. These “non-visible” pollutants are listed below. Non-visible pollutants require monitoring when there is a failure to implement a BMP or in the event there is a spill, breach, malfunction, failure and/or leakage observed during a visual inspection which could result in the discharge of these pollutants to surface waters that would not be visually detectable in storm water. Following is the list of pollutants:

- None.

Based on the pollutants identified above, the following indicator parameters will be analyzed, as applicable, to assess if pollutants are potentially being conveyed from the site by storm water:

- None

Sampling and Analysis

- General - Grab samples shall be collected as follows:
 - Water samples shall be large enough to characterize the site conditions.
 - Samples shall be collected at all discharge locations that can be safely accessed.
- Locations
 - **Discharge points** – Samples shall be collected in areas associated with the pollutants identified above. Samples shall be collected down-gradient of the area(s) affected by any breach, malfunction, leakage, or spill observed during a visual inspection which could result in the discharge of pollutants to surface waters that would not be visually detectable in storm water. Sample locations where samples for unplanned discharges are taken will be added to Appendix XI.I.
 - **Uncontaminated Sample** – A sufficiently large sample of storm water shall be collected that has not come in contact with the disturbed soil or the materials stored or used on-site (uncontaminated sample) for comparison with the discharge sample. This sample location(s) is identified and described in Appendix XI.I.
- Frequency
 - Samples shall be collected during the first two hours of discharge from rain events that occur during daylight hours and which generate runoff.
- Parameters
 - Samples shall be analyzed for:
 - pH;
 - Turbidity.

- Dischargers shall modify their M&RP to address any additional parameters in accordance with any updated SWPPP pollutant source assessment.
- Sampling and Analysis
 - Section 4 and 5 (M&RP) contains the details of the sampling and analysis requirements for the applicable parameters.
- Reporting
 - In the event any effluent sample exceeds an applicable NAL, the LRP shall electronically submit all sampling results from the field tests for that storm event to the SWRCB no later than 10 days after the conclusion of the storm event.
 - All storm event sampling results from laboratory tests (e.g., BOD) shall be retained in the SWPPP and submitted to the SWRCB in the annual report.
- Records
 - Retain all field and/or analytical data in the SWPPP document. Generally all sampling and analysis related records are required to be retained for a minimum of three years. See M&RP Section 11 for record retention requirements.

B. Sampling Collection Exemptions

Samples are not required to be collected under the following conditions:

- During dangerous weather conditions such as flooding and electrical storms.
- Outside of scheduled site business hours.
- When access to the site is unsafe due to storm events.

If a required sample is not collected due to these exceptions, an explanation shall be included in the SWPPP (Appendix XI.G) and in the Annual Report documenting why the sampling was not conducted.

4. EFFLUENT AND RECEIVING WATER SAMPLE COLLECTION AND HANDLING INSTRUCTIONS

This section describes the instructions for sample collection and handling and includes:

- Detailed procedures for sample collection, storage, preservation, and shipping to the testing lab to assure that consistent quality control and quality assurance is maintained.
- An example Chain of Custody form to be used when handling and shipping samples.
- Identification of the analytical methods and related method detection limits (if applicable) for each parameter.

A. General Requirements

- Ensure that water samples are large enough to characterize the site conditions.
- Sampling and sample preservation shall be conducted in accordance with the current edition of "Standard Methods for the Examination of Water and Wastewater" (American Public Health Association).
- All monitoring instruments and equipment (including a discharger's own field instruments for measuring pH and turbidity) should be calibrated and maintained in accordance with manufacturers' specifications to ensure accurate measurements.
- All laboratory analyses shall be conducted according to test procedures under 40 CFR Part 136, unless other test procedures have been specified in this General Permit or by the Regional Water Board. With the exception of field analysis conducted by the discharger for turbidity and pH, all analyses should be sent to and conducted at a laboratory certified for such analyses by the State Department of Health Services.
- The discharger can conduct their own field analysis of pH and may conduct their own field analysis of turbidity if the discharger has sufficient capability (qualified and trained employees, properly calibrated and maintained field instruments, etc.) to adequately perform the field analysis.

Specific procedures are described below for parameters that are analyzed in the field and for parameters that are analyzed in a certified laboratory.

1. For Parameters Analyzed in the Field

pH:

- Sampling and Analyses:
 - Effluent and receiving water sample locations are identified in Appendix XI.I.
 - Field meters will be calibrated, maintained, and operated by trained staff according to the manufacturer's specifications, and calibration records will be stored in Appendix XI.B
 - Sampling and analysis for this parameter shall be conducted on-site by trained personnel with a portable field instrument in accordance with the instrument's instructions.
 - Sampling shall be conducted also in accordance with the field QA/QC document in Appendix XI.J.
 - Section 5 and Table 1 provide the Test Method, Protocol, Minimum Detection Limit, Reporting Units and NALs.

Turbidity:

- Sampling and Analyses:
 - Effluent and receiving water sample locations are identified in Appendix XI.I.
 - Field meters will be calibrated, maintained, and operated by trained staff according to the manufacturer's specifications, and calibration records will be stored in Appendix XI.B
 - Sampling and analysis for this parameter shall be conducted on-site by trained personnel with a portable field instrument in accordance with the instrument's instructions.
 - Sampling shall be conducted also in accordance with the field QA/QC document in Appendix XI.J.
 - Section 5 and Table 1 provides the Test Method, Protocol, Minimum Detection Limit, Reporting Units and NALs.

2. For Parameters Analyzed in a Laboratory

General: The laboratory will provide properly cleaned and preserved (if applicable) sampling containers (bottles) for the samples, and labels on the sample bottles. The sample bottle labels will identify the analysis to be performed and any preservative contained in the bottles, and provide room for recording the sample location and time and date of collection. The laboratory will also provide chain-of-custody forms. An example Chain of Custody form is located in Appendix I.

Personnel shall be designated and trained to collect, maintain, and ship samples in accordance with the Surface Water Ambient Monitoring Program's (SWAMP) 2008 Quality Assurance Program Plan (QAPrP). These personnel are identified in Appendix XIII. See Section 4.h.xii on page 41 of Attachment A of the CGP for additional information regarding SWAMP and QAPrP.

Other Parameters (when applicable):

- Sampling:
 - Collect samples during the first two hours of discharge from rain events that occur during business hours and which generate runoff. For non-visible pollutants, collect 3 samples per day of the qualifying rain event.
 - Collect a sample of storm water that has not come in contact with the disturbed soil or the materials stored or used on-site (uncontaminated sample) for comparison with the discharge sample.
 - Effluent sample locations are identified in Appendix XI.I.
 - Sampling shall be conducted by trained personnel in accordance with the field QA/QC document in Appendix XI.J.
 - Samples shall be collected only in containers provided by the laboratory to which they will be sent.

- Samples will be preserved in accordance with Table 2.
- Samples shall be shipped using a using a method so that the laboratory receives them the same day or no later than 48 hours from their physical sampling (unless otherwise required by the laboratory).
- Analysis:
 - The QSP shall compare the uncontaminated sample to the samples of discharge using field analysis or through laboratory analysis.
 - Section 5 and Table 2 provides the test method, minimum sample volume, sampling container, preservative and holding time for the expected parameters.
 - If these analyses are required, samples will be sent to the laboratory identified in Appendix XI.H.

Table 1 - Testing methods, detection limits, reporting units and applicable NALs for pH and Turbidity (from Attachment A of the CGP).

Parameter	Test Method / Protocol	Discharge Type	Min. Detection Limit	Reporting Units	Numeric Action Level	Numeric Effluent Limitation
pH	Field test with calibrated portable instrument	Risk Type 2 or 3 discharges	0.2	pH	lower NAL = 6.5 upper NAL = 8.5	N/A
Turbidity EPA	EPA 0180.1 and/or field test with calibrated portable instrument	Risk Type 2 or 3 discharges other than ATS	1	NTU	250 NTU	N/A
		For ATS discharges	1	NTU	N/A	10 NTU for Daily Weighted Average & 20 NTU for Any Single Sample

¹ ASTM, 1999, Standard Test Method for Determining Sediment Concentration in Water Samples: American Society of Testing and Materials, D 3977-97, Vol. 11.02, pp. 389-394.

Table 2 – Applicable Sample Collection Information for Parameters to be Analyzed at a Certified Laboratory

Analyte	EPA Analytical Method Number	Minimum Sample Volume ³	Sampling Container	Preservative ⁴	Holding Time
None					

³Minimum sample volume recommended. Specific volume requirements will vary by laboratory and must be verified with the laboratory when bottles are ordered.

⁴Do not pre-rinse or overfill sample containers that contain preservative.

⁵All samples must be kept chilled to 4°C (keep samples on ice for delivery to analytical laboratory)

5. ANALYTICAL AND MONITORING METHODS

A. Effluent Sampling Methods

Refer to Table 1 in Section 4 above for test methods, detection limits, and reporting units.

- **pH:** Perform pH analysis on-site with a calibrated pH meter or pH test kit. Record pH results on paper and retain in Appendix XI.B. in accordance with the M&RP Records Section 11.
- **Turbidity:** Perform turbidity analysis using a calibrated turbidity meter (turbidimeter), either on-site or at an accredited lab. Acceptable test methods include Standard Method 2130 or USEPA Method 180.1. The results will be recorded in Nephelometric Turbidity Units (NTU). The results shall be recorded on paper and retained in Appendix XI.B in accordance with the M&RP Records Section 11.

Evaluation of Results

pH and turbidity NALs are based on daily average sampling results from the project site. Therefore, all daily sample results for each parameter shall be averaged together and compared to the NALs. When the daily average sample result is not within the required NAL, immediately contact the Company representative to conduct the applicable SWRCB NAL reporting.

B. Non-Visible Pollutants

Refer to Table 2 in Section 4 above for analytical methods for non-visible pollutants.

Evaluation of Results

Segment 8 of Sycamore to Peñasquitos – 230 kV Transmission Line Project is located in Los Peñasquitos Hydrologic Unit/Miramar Reservoir Hydrologic Area (906.10). The Water Quality Control Plan for the San Diego Region (“Basin Plan”) provides water quality objectives for some of the analytes that will be monitored. While these do not constitute a discharge standard or limit, these water quality objectives will be used as decision making benchmark standards. Where such standards are not available through the Basin Plan, benchmark standards set forth by other agencies will be used for decision making purposes.

Table 3 – Benchmarks for Review of Non-Visible Pollutants

Benchmark Criteria for Decision Making		
Analyte	Benchmark Concentration	Reference

*United States Environmental Protection Agency Multi-Sector Industrial Permit

6. NAL EXCEEDANCE REPORTS

In the event any effluent sample exceeds an applicable NAL, the LRP shall electronically submit all sampling results from the field tests for that storm event to the SWRCB no later than 10 days after the conclusion of the storm event. The RWQCBs have the authority to require the submittal of an NAL Exceedance Report. A blank NAL Exceedance Report form is located in Appendix I. The report shall include the following information:

- The analytical method(s), method reporting unit(s), and method detection limit(s) of each analytical parameter (analytical results that are less than the method detection limit shall be reported as “less than the method detection limit”).
- The date, place, time of sampling, visual observation (inspections), and/or measurements, including precipitation.
- A description of the current BMPs associated with the effluent sample that exceeded the NAL and the proposed corrective actions taken.

If required to submit a NAL Exceedance report, the LRP shall certify each NAL Exceedance Report and an electronic or paper copy of the NAL Exceedance Report shall be maintained for a minimum of three years after the date the Report is filed. Place a copy of the NAL Exceedance Report (or a copy of the electronic filing) in Appendix XVII.

7. COMPLIANCE STORM EVENT EXEMPTION

This is a Risk Type 2 project area, therefore this section does not apply.

8. WATERSHED MONITORING OPTION

This Project is not part of a qualified regional watershed-based monitoring program; therefore, this section is not applicable.

9. PARTICLE SIZE ANALYSIS FOR PROJECT RISK JUSTIFICATION

This Project is not utilizing a sediment basin and/or justifying an alternative project risk.

10. BIOASSESSMENT

This is a Risk Type 2 project area, therefore this section does not apply.

11. RECORDS

The following records of all storm water monitoring information and copies of all reports (including Annual Reports) shall be retained for a period of at least three years. All records shall be retained on-site while construction is ongoing. These records include:

- The date, place, time of facility inspections, sampling, visual observation (inspections), and/or measurements, including precipitation.
- The individual(s) who performed the facility inspections, sampling, visual observation (inspections), and or measurements.
- The date and approximate time of analyses.
- The individual(s) who performed the analyses.
- A summary of all analytical results from the last three years, the method detection limits and reporting units, the analytical techniques or methods used, and the chain of custody forms.
- Rain gauge readings from site inspections.
- Quality assurance/quality control records and results.
- Non-storm water discharge inspections and visual observation (inspections) and storm water discharge visual observation records.
- Visual observation and sample collection exception records.
- The records of any corrective actions and follow-up activities that resulted from analytical results, visual observation (inspections), or inspections.

APPENDIX X CONSTRUCTION SITE MONITORING AND REPORTING PROGRAM (M&RP) FOR RISK TYPE 3 PROJECT AREAS

1. OVERVIEW

This appendix contains the Construction Site Monitoring & Reporting Program (M&RP) and includes the required monitoring procedures and instructions, location maps, forms and checklists.

The following area within the project limits are considered Type 3:

Area	From	To
	GPS\Description	GPS\Description
Segment 7C: Costal Zone Boundary	32.89926°N, -117.20886°W	32.91185°N, -117.21662°W

Type 3 areas are required to conduct:

- Visual Inspections;
- Storm Water Effluent Monitoring;
- Receiving Water Monitoring (under certain conditions);
- Non-Visible Pollutant Monitoring; and
- Bioassessment (under certain conditions).

The Monitoring and Reporting Program (M&RP) shall be:

- Prepared prior to the start of construction; and
- Implemented immediately at the start of construction and until construction activity is complete and the site is stabilized.

Implementation of this M&RP shall be at the appropriate level to protect water quality at all times throughout the life of the project.

The M&RP shall be revised when:

- Site conditions or construction activities change such that a change in monitoring is required to comply with the requirements and intent of the Construction General Permit (CGP);
- The Regional Water Quality Control Board requires the discharger to revise its M&RP based on its review of the document (revisions shall be submitted via postal mail or electronic e-mail); or
- The Regional Water Quality Control Board requires additional monitoring and reporting program requirements including sampling and analysis of discharges to CWA § 303(d)-listed water bodies, where these additional requirements are consistent with the overall monitoring effort in the receiving waters.

Type 3 areas are also subject to Numeric Action Levels (NALs). When any of these NALs are not met, specific actions are required to be taken. The NAL requirements

are described below.

2 VISUAL MONITORING (INSPECTION) REQUIREMENTS

The visual observations (inspections) described in this M&RP are specific to sampling events and do not serve the same purpose as the site inspections described in Appendix VIII of this SWPPP.

Daily inspections, rain event and post-construction inspections shall be conducted as described below.

- Daily visual inspections:
 - Shall be conducted by trained personnel (record the names and contact information of the assigned inspection personnel in Appendix XIII);
 - Shall be conducted:
 - During working hours;
 - In conjunction with other daily activities; and
 - In areas where active construction is occurring.
 - Shall be conducted to verify that appropriate BMPs for storm water and non-storm water are being implemented and in place in areas where active construction is occurring (including staging areas).
 - May be discontinued in non-active construction areas where:
 - Soil-disturbing activities are completed; and
 - Final stabilization is achieved (e.g., paving is completed, substructures are installed, vegetation meets minimum cover for final stabilization, or other stabilization requirements are met).
 - Must be logged with the following information retained in Appendix XI.G:
 - Date and time of the inspection; and
 - Name of the person who conducted the inspection.
- Rain event inspections:
 - Shall be conducted by trained personnel (record the names and contact information of the assigned inspection personnel in Appendix XIII);
 - Shall be conducted in areas where active construction is occurring:
 - Prior to anticipated storm events;
 - For each 48-hour period during extended working storm events (during normal working hours); and
 - After actual storm events.
 - Shall be conducted to:
 - Identify areas contributing to a discharge of storm water associated with construction activities;
 - **Pre-storm:** Ensure that BMPs are properly installed and maintained; and
 - **Post-storm:** Ensure that BMPs have functioned adequately.
 - Photographs shall be:

- Taken during inspections before, during and after storm events; and
- Submitted through the SWRCB's SMARTS website once every three rain events.
- May be discontinued in non-active construction areas where:
 - Soil-disturbing activities are completed; and
 - Final stabilization is achieved (e.g., paving is completed, substructures are installed, vegetation meets minimum cover for final stabilization, or other stabilization requirements are met).
- Rain gauges:
 - If possible, a rain gauge shall be installed on-site at an accessible and secure location;
 - Readings from a rain gauge shall be made during all rain storm event inspections;
 - Rain gauge readings shall be obtained from the closest rain gauge with publically available data when:
 - ◆ Readings from the on-site gauge (if present) are unavailable; or
 - ◆ No on-site rain gauge is present.
- Must be logged with the following information retained in Appendix XI.G:
 - Date and time of the inspection; and
 - Name of the person who conducted the inspection.
- Post-construction (i.e., where temporary and permanent stabilization BMPs are required after active construction is complete) inspections:
 - Are required where temporary and permanent stabilization BMPs are required after active construction is complete;
 - Shall be conducted by trained personnel (record the names and contact information of the assigned inspection personnel in Appendix XIII);
 - Inspections shall:
 - Ensure that BMPs are adequate and maintained; and
 - Continue until adequate permanent stabilization is established and, in vegetated areas, until minimum vegetative coverage is established in accordance with the CGP.
- A blank Visual Observation form is provided in Appendix XI.I. The QSP must complete these forms during the visual observation and insert a completed copy in Appendix XI.G.

Inspection Exemptions

Inspections are not required to be conducted under the following conditions:

- During dangerous weather conditions such as flooding and electrical storms.
- Outside of scheduled site business hours.
- When access to the site is unsafe due to storm events.

If no required inspections are conducted due to these exceptions, an explanation shall be included in the SWPPP (Appendix XI.G) and in the Annual Report documenting why the sampling was not conducted.

3. WATER QUALITY SAMPLING AND ANALYSIS

Sampling and analysis is required for site effluents and, in specific circumstances, sampling and analysis of receiving waters is required.

This Project area is a Risk Type 3. The CGP requires samples of the following effluents:

- Storm water, including discharges from stored or contained storm water and from Active Treatment Systems when they are utilized;
- Non-storm water and authorized non-storm water discharges; and
- Non-visible pollutant discharges, including:
 - Any parameters (if applicable) indicating the presence of pollutants identified in the list of potential pollutant sources listed in Appendix V;
 - The discharge of pollutants to surface waters that would not be visually detectable in storm water from a spill or during discharges resulting from a breach, malfunction, failure and/or leak of any BMP. Failure to implement BMPs may also require sample collection; and
 - A sample of stormwater that hasn't come in contact with the disturbed soil or the materials stored or used on-site (uncontaminated sample).

Receiving water sampling is required in the event the storm water discharge exceeds the daily average receiving water monitoring trigger of 500 NTU turbidity or the daily average pH range 6.0-9.0 and the project discharges directly into the receiving water.

A. Effluent Monitoring Requirements

1. Storm Water Sampling and Analysis

- General - Storm water grab samples shall be collected as follows:
 - The storm water grab sample(s) obtained shall **be representative of the flow and characteristics** of the discharge.
 - Sampling and analysis of storm water discharges shall be conducted to **characterize discharges associated with construction activity** from the **entire project disturbed area**.
- Locations
 - **Discharge points** - Samples shall be collected from sampling locations characterizing discharges associated with activity from the project's active areas of construction. The sample locations are described in Appendix XI.I.

- **Contained storm water** – Samples shall be collected from stored or contained storm water (i.e., subsequent to a storm event producing precipitation of ½” or more at the time of discharge). The sample locations are described in Appendix XI.I.
- **Run-on from surrounding areas** – Samples may be collected and reported from run-on if there is reason to believe run-on may contribute to an exceedance of Numeric Action Levels or Numeric Effluent Limits. The sample locations are described in Appendix XI.I.
- **Active Treatment System (ATS)** – When an ATS is used on the project, effluent samples and measurements shall be obtained from the discharge pipe or another location representative of the nature of the discharge. ATS is not applicable to this project.
- Frequency
 - Non-contained storm water:
 - At minimum, 3 samples per day of discharge shall be collected.
 - Contained or stored storm water:
 - Grab samples shall be collected daily of stored or contained storm water that are from discharges subsequent to a rain event (producing precipitation of ½ inch or more at the time of discharge).
- Parameters
 - Samples shall be analyzed for:
 - pH;
 - Turbidity; and
 - The following additional parameters for which monitoring is required by the RWQCB:
 - ◆ None
 - Sites that have exceeded Receiving Water Monitoring Trigger for turbidity shall also analyze subsequent storm water effluent samples for turbidity and Suspended Sediment Concentration (SSC). If this occurs, modify Appendix XI.I to include SSC.
- Sampling and Analysis
 - Section 4 and 5 (M&RP) contains the details of the sampling and analysis requirements for the applicable parameters.
- Reporting
 - All storm event sampling results from field test shall be submitted to the State Water Resources Control Board (SWRCB) no later than 5 days after the conclusion of the storm event.
 - NAL Exceedances - The Regional Boards have the authority to require the submittal of an NAL Exceedance Report. If a report is required, see M&RP Section 6 for further details.

- Records
 - Generally all sampling and analysis related records are required to be retained for a minimum of three years. See M&RP Section 10 for record retention requirements.

2. Non-Visible Pollutant Sampling and Analysis

Potential Pollutant Sources

Some pollutants may be discharged to surface waters that would not be visually detectable in storm water. Sampling for these pollutants is only required when:

- The discharger believes pollutants associated with construction activities have the potential to be discharged with storm water runoff due to a spill or in the event there was a breach, malfunction, failure and/or leak of any BMP. Also, failure to implement BMPs may require sample collection.

Storm water monitoring will be performed in conjunction with storm event visual inspections that are required under the CGP. The following inspection forms shall be completed:

- For non-storm water: Visual Observation (Inspection) form for Non-Storm Water Discharges (Blank Form in Appendix I / Completed Form in Appendix XI.G).
- Sampling Event Worksheet (Blank Form in Appendix I / Completed Form in Appendix XI.B)

Construction Materials

A list of the project potential pollutants is located in Appendix V. The list of potential pollutants generated includes all pollutants that would be non-visible in stormwater runoff that are known or should be known to occur on the construction site. These “non-visible” pollutants are listed below. Non-visible pollutants require monitoring when there is a failure to implement a BMP or in the event there is a spill, breach, malfunction, failure and/or leakage observed during a visual inspection which could result in the discharge of these pollutants to surface waters that would not be visually detectable in storm water. Following is the list of pollutants:

- None

Based on the pollutants identified above, the following indicator parameters will be analyzed, as applicable, to assess if pollutants are potentially being conveyed from the site by storm water:

- None

Sampling and Analysis

- General - Grab samples shall be collected as follows:
 - Water samples shall be large enough to characterize the site conditions.
 - Samples shall be collected at all discharge locations that can be safely accessed.
- Locations
 - **Discharge points** – Samples shall be collected in areas associated with the pollutants identified above. Samples shall be collected down-gradient of the area(s) affected by any breach, malfunction, leakage, or spill observed during a visual inspection which could result in the discharge of pollutants to surface waters that would not be visually detectable in storm water. Sample locations where samples for unplanned discharges are taken will be added to Appendix XI.I.
 - **Uncontaminated Sample** – A sufficiently large sample of storm water shall be collected that has not come in contact with the disturbed soil or the materials stored or used on-site (uncontaminated sample) for comparison with the discharge sample. This sample location(s) is identified and described in Appendix XI.I.
- Frequency
 - Samples shall be collected during the first two hours of discharge from rain events that occur during daylight hours and which generate runoff.
- Parameters
 - Samples shall be analyzed for:
 - pH;
 - Turbidity.
 - Dischargers shall modify their M&RP to address any additional parameters in accordance with any updated SWPPP pollutant source assessment.
- Sampling and Analysis
 - Section 4 and 5 (M&RP) contains the details of the sampling and analysis requirements for the applicable parameters.
- Reporting
 - All storm event sampling results from field tests (e.g., pH) shall be submitted to the SWRCB no later than 5 days after the conclusion of the storm event.
 - All storm event sampling results from laboratory tests (e.g., BOD) shall be retained in the SWPPP and submitted to the SWRCB in the annual report.

- Records
 - Retain all field and/or analytical data in the SWPPP document. Generally all sampling and analysis related records are required to be retained for a minimum of three years. See M&RP Section 10 for record retention requirements.

B. Receiving Water Monitoring Requirements

Receiving water monitoring will be required if the effluent monitoring results exceed the receiving water monitoring triggers. When receiving water monitoring is required, the receiving water must be sampled for all of the following parameter(s) through the life of the project:

- Turbidity;
- SSC (if the turbidity trigger is exceeded);
- pH (if applicable); and
- Any additional parameters for which monitoring is required by the Regional Water Board.

Sampling and Analysis

- General - Grab samples shall be collected as follows:
 - Water samples shall be large enough to characterize the site conditions.
 - Samples shall be collected at specified receiving water locations that can be safely accessed.
 - Receiving Water Sample Locations - Samples shall be collected at an upstream/up-gradient location and a downstream/down-gradient location.
 - ◆ **Upstream/upgradient location** – This sample location shall be representative, accessible, and as close as possible and upstream from the effluent discharge point. The sample location is described in Appendix XI.I
 - ◆ **Downstream/down-gradient location** - This sample location shall be representative, accessible, and as close as possible and downstream from the effluent discharge point. The sample location is described in Appendix XI.I.
- Frequency
 - Sample each day of storm water discharge from the affected outfall.
- Parameters
 - Samples shall be analyzed for:
 - pH (if applicable);
 - Turbidity;
 - SSC (if the turbidity trigger is exceeded); and
 - The following additional parameters for which monitoring is required by the RWQCB:

◆ None

- Sampling and Analysis
 - pH and turbidity samples shall normally be conducted using field instruments.
 - When applicable, analysis of additional parameters specified by the RWQCB will be conducted in accordance with Sections 4 and 5 of this M&RP.
- Reporting
 - All storm event sampling results from field tests (e.g., pH) shall be submitted to the State Water Resources Control Board (SWRCB) no later than 5 days after the conclusion of the storm event.
 - All storm event sampling results from laboratory tests (e.g., BOD) shall be retained in the SWPPP and submitted to the SWRCB in the annual report.
- Records
 - Generally all sampling and analysis related records are required to be retained for a minimum of three years. See M&RP Section 10 for record retention requirements.

C. Sampling Collection Exemptions

Samples are not required to be collected under the following conditions:

- During dangerous weather conditions such as flooding and electrical storms.
- Outside of scheduled site business hours.
- When access to the site is unsafe due to storm events.

If no required samples are collected due to these exceptions, an explanation shall be included in the SWPPP (Appendix XI.G) and in the Annual Report documenting why the sampling was not conducted.

4. EFFLUENT AND RECEIVING WATER SAMPLE COLLECTION AND HANDLING INSTRUCTIONS

This section describes the instructions for sample collection and handling and includes:

- Detailed procedures for sample collection, storage, preservation, and shipping to the testing lab to assure that consistent quality control and quality assurance is maintained.
- An example Chain of Custody form to be used when handling and shipping samples.
- Identification of the analytical methods and related method detection limits (if applicable) for each parameter.

A. General Requirements

- Ensure that water samples are large enough to characterize the site conditions.
- Sampling and sample preservation shall be conducted in accordance with the current edition of "Standard Methods for the Examination of Water and Wastewater" (American Public Health Association).
- All monitoring instruments and equipment (including a discharger's own field instruments for measuring pH and turbidity) should be calibrated and maintained in accordance with manufacturers' specifications to ensure accurate measurements.
- All laboratory analyses shall be conducted according to test procedures under 40 CFR Part 136, unless other test procedures have been specified in this General Permit or by the Regional Water Board. With the exception of field analysis conducted by the discharger for turbidity and pH, all analyses should be sent to and conducted at a laboratory certified for such analyses by the State Department of Health Services (SSC exception).
- The discharger can conduct their own field analysis of pH and may conduct their own field analysis of turbidity if the discharger has sufficient capability (qualified and trained employees, properly calibrated and maintained field instruments, etc.) to adequately perform the field analysis.

Specific procedures are described below for parameters that are analyzed in the field and for parameters that are analyzed in a certified laboratory.

1. For Parameters Analyzed in the Field

pH:

- Sampling and Analyses:
 - Effluent and receiving water sample locations are identified in Appendix XI.I.
 - Field meters will be calibrated, maintained, and operated by trained staff according to the manufacturer's specifications, and calibration records will be stored in Appendix XI.B
 - Sampling and analysis for this parameter shall be conducted on-site by trained personnel with a portable field instrument in accordance with the instrument's instructions.
 - Sampling shall be conducted also in accordance with the field QA/QC document in Appendix XI.J.
 - Section 5 and Table 1 provide the Test Method, Protocol, Minimum Detection Limit, Reporting Units, NALs and Receiving Water Monitoring Triggers.

Turbidity:

- Sampling and Analyses:
 - Effluent and receiving water sample locations are identified in Appendix XI.I.

- Field meters will be calibrated, maintained, and operated by trained staff according to the manufacturer's specifications, and calibration records will be stored in Appendix XI.B
- Sampling and analysis for this parameter shall be conducted on-site by trained personnel with a portable field instrument in accordance with the instrument's instructions.
- Sampling shall be conducted also in accordance with the field QA/QC document in Appendix XI.J.
- Section 5 and Table 1 provides the Test Method, Protocol, Minimum Detection Limit, Reporting Units, NALs and Receiving Water Monitoring Triggers.

2. For Parameters Analyzed in a Laboratory

General: The laboratory will provide properly cleaned and preserved (if applicable) sampling containers (bottles) for the samples, and labels on the sample bottles. The sample bottle labels will identify the analysis to be performed and any preservative contained in the bottles, and provide room for recording the sample location and time and date of collection. The laboratory will also provide chain-of-custody forms. An example Chain of Custody form is located in Appendix I.

Personnel shall be designated and trained to collect, maintain, and ship samples in accordance with the Surface Water Ambient Monitoring Program's (SWAMP) 2008 Quality Assurance Program Plan (QAPrP). These personnel are identified in Appendix XIII. See Section 4.h.xii on page 41 of Attachment A of the CGP for additional information regarding SWAMP and QAPrP.

SSC (when applicable):

- Sampling:
 - Effluent and receiving water sample locations are identified in Appendix XI.I.
 - Sampling shall be conducted by trained personnel in accordance with the field QA/QC document in Appendix XI.J.
 - Samples shall be collected only in containers provided by the laboratory to which they will be sent.
 - Samples shall be preserved in accordance with ASTM Method D3977-97.
 - Samples shall be shipped using a method so that the laboratory receives them the same day or no later than 48 hours from their physical sampling (unless otherwise required by the laboratory).
- Analysis:
 - Section 5 and Table 1 provides the Test Method, Protocol, Minimum Detection Limit, Reporting Units, NALs and Receiving Water Monitoring Triggers.

- If this analysis is required, samples will be sent to the laboratory identified in Appendix XI.H.

Other Parameters (when applicable):

- Sampling:
 - Collect samples during the first two hours of discharge from rain events that occur during business hours and which generate runoff. For non-visible pollutants, collect 3 samples per day of the qualifying rain event.
 - Collect a sample of storm water that has not come in contact with the disturbed soil or the materials stored or used on-site (uncontaminated sample) for comparison with the discharge sample.
 - Effluent sample locations are identified in Appendix XI.I.
 - Sampling shall be conducted by trained personnel in accordance with the field QA/QC document in Appendix XI.J.
 - Samples shall be collected only in containers provided by the laboratory to which they will be sent.
 - Samples will be preserved in accordance with Table 2.
 - Samples shall be shipped using a method so that the laboratory receives them the same day or no later than 48 hours from their physical sampling (unless otherwise required by the laboratory).

- Analysis:
 - The QSP shall compare the uncontaminated sample to the samples of discharge using field analysis or through laboratory analysis.
 - Section 5 and Table 2 provides the test method, minimum sample volume, sampling container, preservative and holding time for the expected parameters.
 - If these analyses are required, samples will be sent to the laboratory identified in Appendix XI.H.

Table 1 - Testing methods, detection limits, reporting units and applicable NALs (from Attachment A of the CGP).

Parameter	Test Method / Protocol	Discharge Type	Min. Detection Limit	Reporting Units	Numeric Action Level	Receiving Water Monitoring Trigger
pH	Field test with calibrated portable instrument	Risk Type 3 discharges	0.2	pH	lower NAL = 6.5 upper NAL = 8.5	lower = 6.0 upper = 9.0
Turbidity	EPA 0180.1 and/or field test with calibrated portable instrument	Risk Type 3 discharges other than ATS	1	NTU	250 NTU	500 NTU
		For ATS discharges	1	NTU	N/A	10 NTU for Daily Weighted Average & 20 NTU for Any Single Sample
SSC	ASTM Method D 3977-97 ¹	Risk Type 3 (if Receiving Water Monitoring Trigger is exceeded)	5	mg/L	N/A	N/A

¹ ASTM, 1999, Standard Test Method for Determining Sediment Concentration in Water Samples: American Society of Testing and Materials, D 3977-97, Vol. 11.02, pp. 389-394.

Table 2 – Applicable Sample Collection Information for Parameters to be Analyzed at a Certified Laboratory

Analyte	EPA Analytical Method Number	Minimum Sample Volume ³	Sampling Container	Preservative ⁴	Holding Time
None					

³Minimum sample volume recommended. Specific volume requirements will vary by laboratory and must be verified with the laboratory when bottles are ordered.

⁴Do not pre-rinse or overfill sample containers that contain preservative.

⁵All samples must be kept chilled to 4°C (keep samples on ice for delivery to analytical laboratory)

5. ANALYTICAL AND MONITORING METHODS

A. Effluent Sampling Methods

Refer to Table 1 in Section 4 above for test methods, detection limits, and reporting units.

- **pH:** Perform pH analysis on-site with a calibrated pH meter or pH test kit. Record pH results on paper and retain in Appendix XI.B. in accordance with the M&RP Records Section 10.
- **Turbidity:** Perform turbidity analysis using a calibrated turbidity meter (turbidimeter), either on-site or at an accredited lab. Acceptable test methods include Standard Method 2130 or USEPA Method 180.1. The results will be recorded in Nephelometric Turbidity Units (NTU). The results shall be recorded on paper and retained in Appendix XI.B in accordance with the M&RP Records Section 10.
- **Suspended Sediment Concentration (SSC):** Perform SSC analysis using ASTM Method D3977-97.

Evaluation of Results

pH and turbidity NALs are based on daily average sampling results from the project site. Therefore, all daily sample results for each parameter shall be averaged together and compared to the NALs. When the daily average sample result is not within the required NAL, immediately contact the Company representative to conduct the applicable SWRCB NAL reporting.

B. Non-Visible Pollutants

Refer to Table 2 in Section 4 above for analytical methods for non-visible pollutants.

Evaluation of Results

Segments 6 and 7 of Sycamore-Peñasquitos 230 kV Transmission Line Project are located in Los Peñasquitos Hydrologic Unit/Miramar Reservoir Hydrologic Area (906.10). The Water Quality Control Plan for the San Diego Region ("Basin Plan") provides water quality objectives for some of the analytes that will be monitored. While these do not constitute a discharge standard or limit, these water quality objectives will be used as decision making benchmark standards. Where such standards are not available through the Basin Plan, benchmark standards set forth by other agencies will be used for decision making purposes.

Table 3 – Benchmarks for Review of Non-Visible Pollutants

Benchmark Criteria for Decision Making		
Analyte	Benchmark Concentration	Reference

*United States Environmental Protection Agency Multi-Sector Industrial Permit

6. NAL EXCEEDANCE REPORTS

If any effluent sample exceeds an applicable NAL, the LRP shall electronically submit all storm event sampling results to the State Water Board no later than 10 days after the conclusion of the storm event. The RWQCBs have the authority to require the submittal of an NAL Exceedance Report. A blank NAL Exceedance Report form is located in Appendix I. The report shall include the following information:

- The analytical method(s), method reporting unit(s), and method detection limit(s) of each analytical parameter (analytical results that are less than the method detection limit shall be reported as “less than the method detection limit”).
- The date, place, time of sampling, visual observation (inspections), and/or measurements, including precipitation.
- A description of the current BMPs associated with the effluent sample that exceeded the NAL and the proposed corrective actions taken.

If required to submit a NAL Exceedance report, the LRP shall certify each NAL Exceedance Report and an electronic or paper copy of the NAL Exceedance Report shall be maintained for a minimum of three years after the date the Report is filed. Place a copy of the NAL Exceedance Report (or a copy of the electronic filing) in Appendix XVII.

7. WATERSHED MONITORING OPTION

This Project is not part of a qualified regional watershed-based monitoring program; therefore, this section is not applicable.

8. PARTICLE SIZE ANALYSIS FOR PROJECT RISK JUSTIFICATION

This Project is not utilizing a sediment basin and/or justifying an alternative project risk.

9. BIOASSESSMENT

At the time this SWPPP was developed, these project areas were not greater than 30 acres of soil disturbance.

This project does not meet the criteria for requiring a bioassessment; therefore no bioassessment monitoring is required.

10. RECORDS

The following records of all storm water monitoring information and copies of all reports (including Annual Reports) shall be retained for a period of at least three years. All records shall be retained on-site while construction is ongoing. These records include:

- The date, place, time of facility inspections, sampling, visual observation (inspections), and/or measurements, including precipitation.
- The individual(s) who performed the facility inspections, sampling, visual observation (inspections), and or measurements.
- The date and approximate time of analyses.
- The individual(s) who performed the analyses.
- A summary of all analytical results from the last three years, the method detection limits and reporting units, the analytical techniques or methods used, and the chain of custody forms.
- Rain gauge readings from site inspections.
- Quality assurance/quality control records and results.
- Non-storm water discharge inspections and visual observation (inspections) and storm water discharge visual observation records.
- Visual observation and sample collection exception records.
- The records of any corrective actions and follow-up activities that resulted from analytical results, visual observation (inspections), or inspections.

APPENDIX XI
MONITORING AND REPORTING PLAN ATTACHMENTS

APPENDIX XII

PERMIT AND REGISTRATION DOCUMENTS/NOTICE OF TERMINATION

APPENDIX XIII
RESPONSIBLE PARTIES

Appendix XIII List of Responsible Parties

PROJECT Sycamore – Peñasquitos 230 kV
Transmission Line Project

WDID NUMBER:

LEGALLY RESPONSIBLE PART (LRP) **THE LRP's APPROVED SIGNATORY**

AREA OF RESPONSIBILITY:

NAME Scott Pearson **TITLE:** Director of Environmental Services
COMPANY NAME: San Diego Gas & Electric
ADDRESS 8326 Century Park, CP21E
CITY San Diego **STATE** CA **ZIP** 92123
TELEPHONE 858-654-3580
EMERGENCY TELEPHONE
FAX
E-MAIL spearson@semprautilities.com

QUALIFIED SWPPP DEVELOPER (QSD): RESPONSIBLE FOR PREPARING THE SWPPP:

NAME Christian Herencia, QSD/QSP 00389 **TITLE:** Senior Project Engineer
COMPANY NAME: TRC
ADDRESS 4393 Viewridge Avenue, Suite A
CITY San Diego **STATE** CA **ZIP** 92123
TELEPHONE 858-505-8881
EMERGENCY TELEPHONE 858-210-5105
FAX
E-MAIL cherencia@trcsolutions.com

ADDITIONAL QSD:

AREA OF RESPONSIBILITY:

NAME **TITLE:**
COMPANY NAME:
ADDRESS
CITY **STATE** **ZIP**
TELEPHONE
EMERGENCY TELEPHONE
FAX
E-MAIL

START DATE

END DATE

QUALIFIED SWPPP PRACTITIONER (QSP):

AREA OF RESPONSIBILITY:

NAME

TITLE:

COMPANY NAME:

ADDRESS

CITY

STATE

ZIP

TELEPHONE

EMERGENCY TELEPHONE

FAX

E-MAIL

START DATE

END DATE

ADDITIONAL QSP:

AREA OF RESPONSIBILITY:

NAME

TITLE:

COMPANY NAME:

ADDRESS

CITY

STATE

ZIP

TELEPHONE

EMERGENCY TELEPHONE

FAX

E-MAIL

START DATE

END DATE

SPILL RESPONSE PERSONNEL

NAME

SDG&E Hazmat

TITLE:

ADDRESS

6875 Consolidated Way

CITY

San Diego

STATE

CA

ZIP

92121

TELEPHONE

Service Dispatch (**Trouble Hotline**): (619) 725-5100

EMERGENCY TELEPHONE

HazMat Operations Hotline: (858) 549-6519 (After Hours)

FAX

E-MAIL

START DATE

Project Start

END DATE

Project end

SPILL RESPONSE PERSONNEL

NAME _____ TITLE: _____
ADDRESS _____
CITY _____ STATE _____ ZIP _____
TELEPHONE _____
EMERGENCY TELEPHONE _____
FAX _____
E-MAIL _____
START DATE _____ END DATE _____

SPILL RESPONSE PERSONNEL

NAME _____ TITLE: _____
ADDRESS _____
CITY _____ STATE _____ ZIP _____
TELEPHONE _____
EMERGENCY TELEPHONE _____
FAX _____
E-MAIL _____
START DATE _____ END DATE _____

SPILL RESPONSE PERSONNEL

NAME _____ TITLE: _____
ADDRESS _____
CITY _____ STATE _____ ZIP _____
TELEPHONE _____
EMERGENCY TELEPHONE _____
FAX _____
E-MAIL _____
START DATE _____ END DATE _____

STORM WATER SAMPLING AGENT:

CONTACT PERSON _____ **TITLE:** _____
ADDRESS _____
CITY _____ **STATE** _____ **ZIP** _____
TELEPHONE _____
EMERGENCY TELEPHONE _____
FAX _____
E-MAIL _____
START DATE _____ **END DATE** _____

STORM WATER SAMPLING AGENT:

CONTACT PERSON _____ **TITLE:** _____
ADDRESS _____
CITY _____ **STATE** _____ **ZIP** _____
TELEPHONE _____
EMERGENCY TELEPHONE _____
FAX _____
E-MAIL _____
START DATE _____ **END DATE** _____

STORM WATER SAMPLING AGENT:

CONTACT PERSON _____ **TITLE:** _____
ADDRESS _____
CITY _____ **STATE** _____ **ZIP** _____
TELEPHONE _____
EMERGENCY TELEPHONE _____
FAX _____
E-MAIL _____
START DATE _____ **END DATE** _____

STORM WATER SAMPLING AGENT:

CONTACT PERSON	_____	TITLE:	_____
ADDRESS	_____		
CITY	_____	STATE	_____
		ZIP	_____
TELEPHONE	_____		
EMERGENCY TELEPHONE	_____		
FAX	_____		
E-MAIL	_____		
START DATE	_____	END DATE	_____

REGIONAL BOARD CONTACT INFORMATION	RWQCB NAME:	<i>San Diego</i>
CONTACT PERSON	Tony Felix	TITLE: _____
ADDRESS	2375 Northside Drive, Suite 100	
CITY	San Diego	STATE CA
		ZIP 92108
TELEPHONE	619-521-5921	
EMERGENCY TELEPHONE	_____	
FAX	_____	
E-MAIL	tfelix@waterboards.ca.gov	

LOCAL STORM WATER MANAGEMENT AGENCY	AGENCY NAME:	_____
CONTACT PERSON	_____	TITLE: _____
ADDRESS	_____	
CITY	_____	STATE _____
		ZIP _____
TELEPHONE	_____	
EMERGENCY TELEPHONE	_____	
FAX	_____	
E-MAIL	_____	

CONTRACTOR SUBCONTRACTOR INDIVIDUAL DIRECTED BY QSP OTHER

PLEASE CHECK APPROPRIATE BOX ABOVE. IF "OTHER", PLEASE INDICATE:

COMPANY NAME San Diego Gas & Electric

CONTACT PERSON Edith Moreno TITLE: Senior Environmental Services-Water Resources

ADDRESS 1010 Tavern Road, SD1116

CITY Alpine STATE CA ZIP 91901

TELEPHONE 858-503-5211

EMERGENCY TELEPHONE 323-630-9310

FAX

E-MAIL

START DATE END DATE

CONTRACTOR SUBCONTRACTOR INDIVIDUAL DIRECTED BY QSP OTHER

PLEASE CHECK APPROPRIATE BOX ABOVE. IF "OTHER", PLEASE INDICATE:

NAME TITLE:

ADDRESS

CITY STATE ZIP

TELEPHONE

EMERGENCY TELEPHONE

FAX

E-MAIL

START DATE END DATE

CONTRACTOR SUBCONTRACTOR INDIVIDUAL DIRECTED BY QSP OTHER

PLEASE CHECK APPROPRIATE BOX ABOVE. IF "OTHER", PLEASE INDICATE:

NAME TITLE:

ADDRESS

CITY STATE ZIP

TELEPHONE

EMERGENCY TELEPHONE

FAX

E-MAIL

START DATE END DATE

CONTRACTOR SUBCONTRACTOR INDIVIDUAL DIRECTED BY QSP OTHER

PLEASE CHECK APPROPRIATE BOX ABOVE. IF "OTHER", PLEASE INDICATE:

NAME _____ TITLE: _____

ADDRESS _____

CITY _____ STATE _____ ZIP _____

TELEPHONE _____

EMERGENCY TELEPHONE _____

FAX _____

E-MAIL _____

START DATE _____ END DATE _____

CONTRACTOR SUBCONTRACTOR INDIVIDUAL DIRECTED BY QSP OTHER

PLEASE CHECK APPROPRIATE BOX ABOVE. IF "OTHER", PLEASE INDICATE:

NAME _____ TITLE: _____

ADDRESS _____

CITY _____ STATE _____ ZIP _____

TELEPHONE _____

EMERGENCY TELEPHONE _____

FAX _____

E-MAIL _____

START DATE _____ END DATE _____

CONTRACTOR SUBCONTRACTOR INDIVIDUAL DIRECTED BY QSP OTHER

PLEASE CHECK APPROPRIATE BOX ABOVE. IF "OTHER", PLEASE INDICATE:

NAME _____ TITLE: _____

ADDRESS _____

CITY _____ STATE _____ ZIP _____

TELEPHONE _____

EMERGENCY TELEPHONE _____

FAX _____

E-MAIL _____

START DATE _____ END DATE _____

CONTRACTOR SUBCONTRACTOR INDIVIDUAL DIRECTED BY QSP OTHER

PLEASE CHECK APPROPRIATE BOX ABOVE. IF "OTHER", PLEASE INDICATE:

NAME _____ TITLE: _____

ADDRESS _____

CITY _____ STATE _____ ZIP _____

TELEPHONE _____

EMERGENCY TELEPHONE _____

FAX _____

E-MAIL _____

START DATE _____ END DATE _____

CONTRACTOR SUBCONTRACTOR INDIVIDUAL DIRECTED BY QSP OTHER

PLEASE CHECK APPROPRIATE BOX ABOVE. IF "OTHER", PLEASE INDICATE:

NAME _____ TITLE: _____

ADDRESS _____

CITY _____ STATE _____ ZIP _____

TELEPHONE _____

EMERGENCY TELEPHONE _____

FAX _____

E-MAIL _____

START DATE _____ END DATE _____

CONTRACTOR SUBCONTRACTOR INDIVIDUAL DIRECTED BY QSP OTHER

PLEASE CHECK APPROPRIATE BOX ABOVE. IF "OTHER", PLEASE INDICATE:

NAME _____ TITLE: _____

ADDRESS _____

CITY _____ STATE _____ ZIP _____

TELEPHONE _____

EMERGENCY TELEPHONE _____

FAX _____

E-MAIL _____

START DATE _____ END DATE _____

APPENDIX XIV
INSPECTION CHECKLISTS

APPENDIX XV
TRAINING DOCUMENTATION

Qualified SWPPP Developer (QSD) Qualifications

I, **Christian Herencia**, am a Qualified SWPPP Developer (QSD) and hold the following registration(s) and/or certification(s). (Check all that apply and include a copy of the registration(s) and/or certification(s)):

- A California registered professional civil engineer;
- A California registered professional geologist or engineering geologist;
- A California registered landscape architect;
- A professional hydrologist registered through the American Institute of Hydrology;
- A Certified Professional in Erosion and Sediment Control (CPESC)[™] registered through Enviro Cert, International, Inc.;
- A Certified Professional in Storm Water Quality (CPSWQ)[™] registered through Enviro Cert, International, Inc.; or
- A professional in erosion and sediment control registered through the National Institute for Certification in Engineering Technologies (NICET).

-- AND --

The QSD attended formal State Water Board sponsored or approved QSD training course on the following date (a requirement as of September 2, 2011):

Date: November 17-19, 2010
Name of Course: California Construction General Permit
Training - QSD
Presented by: Jane Ledford, JL Stormwater Consultants, Inc.

A copy of the certification of attendance is attached.

Signature: _____

Affix Certificate Number and/or Seal here:

Certificate Number 389

Seal:

Qualified SWPPP Practitioner (QSP) Qualifications

I, **Christian Herencia**, am a Qualified SWPPP Practitioner (QSP)* and hold the following registration(s) and/or certification(s). (Check all that apply and include a copy of the registration(s) and/or certification(s)):

- Qualified SWPPP Developer (QSD)
- A certified erosion, sediment and storm water inspector registered through Enviro Cert, International, Inc.; or
- A certified inspector of sediment and erosion control registered through Certified Inspector of Sediment and Erosion Control, Inc.

* A requirement as of September 2, 2011, the QSP shall be either a QSD or have one of the above certifications:

-- AND --

The QSP attended formal State Water Board sponsored or approved QSP training course on the following date (a requirement as of September 2, 2011):

Date: November 17-19, 2010
Name of Course: California Construction General Permit
Training -QSP
Presented by: Jane Ledford, JL Stormwater Consultants, Inc.

A copy of the certification of attendance is attached.

Signature: _____

Affix Certificate Number and/or Seal here:

Certificate Number 389

Seal:

APPENDIX XVI
AMENDMENT LOG

APPENDIX XVII
REPORTS

APPENDIX XVIII
SECONDARY CONTAINMENT AND SPILL KIT INVENTORY

SECONDARY CONTAINMENT AND SPILL KIT INVENTORY (Store Completed Form in Appendix XVIII)

To be completed by the QSP

- Equipment and materials for cleanup of spills shall be available on site and spills and leaks shall be cleaned up **immediately** and the materials used to clean up the spills shall be disposed of properly; and
- Ensure appropriate spill response personnel are assigned and trained.
- Ensure the containment of washout areas that may contain additional pollutants so that there is no discharge into the underlying soil and/or surrounding areas.

The following spill control equipment can be found on-site:

Quantity ¹	Description ²	Location ³	Absorbent Capacity (Gallons) ⁴
One per truck	Shovel and bucket	Trucks	Five gallons of impacted dirt
One per storage area	Absorbent, socks, wipes	Storage Areas	30 gallons

1 – Number of spill kits or product
 2 - Contents of spill kit or product

3 – Storage location of spill kit or product
 4 – Absorbent capacity of the spill kit or product

Note: Spill response kits come from a variety of suppliers. Kit contents and absorbent capacity may vary from supplier's description.

The following secondary containment equipment can be found on-site:

Description of Material Stored in Secondary Containment ⁵	Location ⁶	Type of Containment/Enclosure ⁷	Volume	
			Maximum Storage/Containment ⁸	Spill Potential ⁹

5- For example, paint, oil, lubricant, solvent, etc.

6- Location of secondary containment

7- Description of the secondary containment enclosure. For example, poly-pack, poly-pallet, cabinet, visqueen-lined sump.

8- Capacity of the secondary device (usually identified on the device or can be obtained from the manufacturer)

9- Quantity of material (in gallons) stored in the secondary containment

Secondary Containment and Spill Kit Inventory

For response to small spills, site spill kits should contain, at a minimum, the following materials:

- 5 gallon D.O.T. bucket (or other suitable container(s) for used absorbent/pads);
- Bag of absorbent; and/or absorbent pads;
- Dust pan and hand broom;
- Eye protection;
- Gloves;
- Hand towels; and
- Plastic bag(s).

APPENDIX XIX
OTHER SWPPP EXHIBITS

APPENDIX XX
ACTIVE TREATMENT SYSTEM
(NOT APPLICABLE)

APPENDIX XXI
BIOASSESSMENT
(NOT APPLICABLE)

APPENDIX XXII
GLOSSARY/ACRONYMS

APPENDIX 5: Glossary

Active Areas of Construction

All areas subject to land surface disturbance activities related to the project including, but not limited to, project staging areas, immediate access areas and storage areas. All previously active areas are still considered active areas until final stabilization is complete. [The construction activity Phases used in this General Permit are the Preliminary Phase, Grading and Land Development Phase, Streets and Utilities Phase, and the Vertical Construction Phase.]

Active Treatment System (ATS)

A treatment system that employs chemical coagulation, chemical flocculation, or electrocoagulation to aid in the reduction of turbidity caused by fine suspended sediment.

Acute Toxicity Test

A chemical stimulus severe enough to rapidly induce a negative effect; in aquatic toxicity tests, an effect observed within 96 hours or less is considered acute.

Air Deposition

Airborne particulates from construction activities. .

Approved Signatory

A person who has legal authority to sign, certify, and electronically submit Permit Registration Documents and Notices of Termination on behalf of the Legally Responsible Person.

Beneficial Uses

As defined in the California Water Code, beneficial uses of the waters of the state that may be protected against quality degradation include, but are not limited to, domestic, municipal, agricultural and industrial supply; power generation; recreation; aesthetic enjoyment; navigation; and preservation and enhancement of fish, wildlife, and other aquatic resources or preserves.

Best Available Technology Economically Achievable (BAT)

As defined by USEPA, BAT is a technology-based standard established by the Clean Water Act (CWA) as the most appropriate means available on a national basis for controlling the direct discharge of toxic and nonconventional pollutants to navigable waters. The BAT effluent limitations guidelines, in general, represent the best existing performance of treatment technologies that are economically achievable within an industrial point source category or subcategory.

Best Conventional Pollutant Control Technology (BCT)

As defined by USEPA, BCT is a technology-based standard for the discharge from existing industrial point sources of conventional pollutants including biochemical oxygen demand (BOD), total suspended sediment (TSS), fecal coliform, pH, oil and grease.

Best Professional Judgment (BPJ)

The method used by permit writers to develop technology-based NPDES permit conditions on a case-by-case basis using all reasonably available and relevant data.

Best Management Practices (BMPs)

BMPs are scheduling of activities, prohibitions of practices, maintenance procedures, and other management practices to prevent or reduce the discharge of pollutants. BMPs also include treatment requirements, operating procedures, and practices to control site runoff, spillage or leaks, sludge or waste disposal, or drainage from raw material storage.

Chain of Custody (COC)

Form used to track sample handling as samples progress from sample collection to the analytical laboratory. The COC is then used to track the resulting analytical data from the laboratory to the client. COC forms can be obtained from an analytical laboratory upon request.

Coagulation

The clumping of particles in a discharge to settle out impurities, often induced by chemicals such as lime, alum, and iron salts.

Common Plan of Development

Generally a contiguous area where multiple, distinct construction activities may be taking place at different times under one plan. A plan is generally defined as any piece of documentation or physical demarcation that indicates that construction activities may occur on a common plot. Such documentation could consist of a tract map, parcel map, demolition plans, grading plans or contract documents. Any of these documents could delineate the boundaries of a common plan area. However, broad planning documents, such as land use master plans, conceptual master plans, or broad-based CEQA or NEPA documents that identify potential projects for an agency or facility are not considered common plans of development.

Daily Average Discharge

The discharge of a pollutant measured during any 24-hour period that reasonably represents a calendar day for purposes of sampling. For pollutants with limitations expressed in units of mass, the daily discharge is calculated as the total mass of the pollutant discharged during the day. For pollutants with limitations expressed in other units of measurement (e.g., concentration) the daily discharge is calculated as the average measurement of the pollutant

throughout the day (40 CFR 122.2). In the case of pH, the pH must first be converted from a log scale.

Debris

Litter, rubble, discarded refuse, and remains of destroyed inorganic anthropogenic waste.

Direct Discharge

A discharge that is routed directly to waters of the United States by means of a pipe, channel, or ditch (including a municipal storm sewer system), or through surface runoff.

Discharger

The Legally Responsible Person (see definition) or entity subject to this General Permit.

Dose Rate (for ATS)

In exposure assessment, dose (e.g. of a chemical) per time unit (e.g. mg/day), sometimes also called dosage.

Drainage Area

The area of land that drains water, sediment, pollutants, and dissolved materials to a common outlet.

Effluent

Any discharge of water by a discharger either to the receiving water or beyond the property boundary controlled by the discharger.

Effluent Limitation

Any numeric or narrative restriction imposed on quantities, discharge rates, and concentrations of pollutants which are discharged from point sources into waters of the United States, the waters of the contiguous zone, or the ocean.

Erosion

The process, by which soil particles are detached and transported by the actions of wind, water, or gravity.

Erosion Control BMPs

Vegetation, such as grasses and wildflowers, and other materials, such as straw, fiber, stabilizing emulsion, protective blankets, etc., placed to stabilize areas of disturbed soils, reduce loss of soil due to the action of water or wind, and prevent water pollution.

Field Measurements

Testing procedures performed in the field with portable field-testing kits or meters.

Final Stabilization

All soil disturbing activities at each individual parcel within the site have been completed in a manner consistent with the requirements in this General Permit.

First Order Stream

Stream with no tributaries.

Flocculants

Substances that interact with suspended particles and bind them together to form flocs.

Good Housekeeping BMPs

BMPs designed to reduce or eliminate the addition of pollutants to construction site runoff through analysis of pollutant sources, implementation of proper handling/disposal practices, employee education, and other actions.

Grading Phase (part of the Grading and Land Development Phase)

Includes reconfiguring the topography and slope including; alluvium removals; canyon cleanouts; rock undercuts; keyway excavations; land form grading; and stockpiling of select material for capping operations.

Hydromodification

Hydromodification is the alteration of the hydrologic characteristics of coastal and non-coastal waters, which in turn could cause degradation of water resources. Hydromodification can cause excessive erosion and/or sedimentation rates, causing excessive turbidity, channel aggradation and/or degradation.

Identified Organisms

Organisms within a sub-sample that is specifically identified and counted.

Inactive Areas of Construction

Areas of construction activity that are not active and those that have been active and are not scheduled to be re-disturbed for at least 14 days.

Index Period

The period of time during which bioassessment samples must be collected to produce results suitable for assessing the biological integrity of streams and rivers. Instream communities naturally vary over the course of a year, and sampling during the index period ensures that samples are collected during a time frame when communities are stable so that year-to-year consistency is obtained. The index period approach provides a cost-effective alternative to year-round sampling. Furthermore, sampling within the appropriate index period will yield results that are comparable to the assessment thresholds or criteria for a given region, which are established for the same index period. Because index

periods differ for different parts of the state, it is essential to know the index period for your area.

K Factor

The soil erodibility factor used in the Revised Universal Soil Loss Equation (RUSLE). It represents the combination of detachability of the soil, runoff potential of the soil, and the transportability of the sediment eroded from the soil.

Legally Responsible Person

The person who possesses the title of the land or the leasehold interest of a mineral estate upon which the construction activities will occur for the regulated site. For linear underground/overhead projects, it is in the person in charge of the utility company, municipality, or other public or private company or agency that owns or operates the LUP.

Likely Precipitation Event

Any weather pattern that is forecasted to have a 50% or greater chance of producing precipitation in the project area. The discharger shall obtain likely precipitation forecast information from the National Weather Service Forecast Office (e.g., by entering the zip code of the project's location at <http://www.srh.noaa.gov/forecast>).

Maximum Allowable Threshold Concentration (MATC)

The allowable concentration of residual, or dissolved, coagulant/flocculant in effluent. The MATC shall be coagulant/flocculant-specific, and based on toxicity testing conducted by an independent, third-party laboratory. A typical MATC would be:

The MATC is equal to the geometric mean of the NOEC (No Observed Effect Concentration) and LOEC (Lowest Observed Effect Concentration) Acute and Chronic toxicity results for most sensitive species determined for the specific coagulant. The most sensitive species test shall be used to determine the MATC.

Natural Channel Evolution

The physical trend in channel adjustments following a disturbance that causes the river to have more energy and degrade or aggrade more sediment. Channels have been observed to pass through 5 to 9 evolution types. Once they pass through the suite of evolution stages, they will rest in a new state of equilibrium.

Non-Storm Water Discharges

Discharges are discharges that do not originate from precipitation events. They can include, but are not limited to, discharges of process water, air conditioner condensate, non-contact cooling water, vehicle wash water, sanitary wastes, concrete washout water, paint wash water, irrigation water, or pipe testing water.

Non-Visible Pollutants

Pollutants associated with a specific site or activity that can have a negative impact on water quality, but cannot be seen through observation (ex: chlorine). Such pollutants being discharged are not authorized.

Numeric Action Level (NAL)

Level is used as a warning to evaluate if best management practices are effective and take necessary corrective actions. Not an effluent limit.

Original Sample Material

The material (i.e., macroinvertebrates, organic material, gravel, etc.) remaining after the subsample has been removed for identification.

pH

Unit universally used to express the intensity of the acid or alkaline condition of a water sample. The pH of natural waters tends to range between 6 and 9, with neutral being 7. Extremes of pH can have deleterious effects on aquatic systems.

Post-Construction BMPs

Structural and non-structural controls which detain, retain, or filter the release of pollutants to receiving waters after final stabilization is attained.

Preliminary Phase (Pre-Construction Phase - Part of the Grading and Land Development Phase)

Construction stage including rough grading and/or disking, clearing and grubbing operations, or any soil disturbance prior to mass grading.

Project**Qualified SWPPP Developer**

Individual who is authorized to develop and revise SWPPPs.

Qualified SWPPP Practitioner

Individual assigned responsibility for non-storm water and storm water visual observations, sampling and analysis, and responsibility to ensure full compliance with the permit and implementation of all elements of the SWPPP, including the preparation of the annual compliance evaluation and the elimination of all unauthorized discharges.

Qualifying Rain Event

Any event that produces 0.5 inches or more precipitation with a 48 hour or greater period between rain events.

R Factor

Erosivity factor used in the Revised Universal Soil Loss Equation (RUSLE). The R factor represents the erosivity of the climate at a particular location. An

average annual value of R is determined from historical weather records using erosivity values determined for individual storms. The erosivity of an individual storm is computed as the product of the storm's total energy, which is closely related to storm amount, and the storm's maximum 30-minute intensity.

Rain Event Action Plan (REAP)

Written document, specific for each rain event, that when implemented is designed to protect all exposed portions of the site within 48 hours of any likely precipitation event.

Remaining Sub sampled Material

The material (e.g., organic material, gravel, etc.) that remains after the organisms to be identified have been removed from the subsample for identification. (Generally, no macroinvertebrates are present in the remaining subsampled material, but the sample needs to be checked and verified using a complete Quality Assurance (QA) plan)

Routine Maintenance

Activities intended to maintain the original line and grade, hydraulic capacity, or original purpose of a facility.

Runoff Control BMPs

Measures used to divert runoff from offsite and runoff within the site.

Run-on

Discharges that originate offsite and flow onto the property of a separate project site.

Revised Universal Soil Loss Equation (RUSLE)

Empirical model that calculates average annual soil loss as a function of rainfall and runoff erosivity, soil erodibility, topography, erosion controls, and sediment controls.

Sampling and Analysis Plan

Document that describes how the samples will be collected, under what conditions, where and when the samples will be collected, what the sample will be tested for, what test methods and detection limits will be used, and what methods/procedures will be maintained to ensure the integrity of the sample during collection, storage, shipping and testing (i.e., quality assurance/quality control protocols).

Sediment

Solid particulate matter, both mineral and organic, that is in suspension, is being transported, or has been moved from its site of origin by air, water, gravity, or ice and has come to rest on the earth's surface either above or below sea level.

Sedimentation

Process of deposition of suspended matter carried by water, wastewater, or other liquids, by gravity. It is usually accomplished by reducing the velocity of the liquid below the point at which it can transport the suspended material.

Sediment Control BMPs

Practices that trap soil particles after they have been eroded by rain, flowing water, or wind. They include those practices that intercept and slow or detain the flow of storm water to allow sediment to settle and be trapped (e.g., silt fence, sediment basin, fiber rolls, etc.).

Settleable Solids (SS)

Solid material that can be settled within a water column during a specified time frame. It is typically tested by placing a water sample into an Imhoff settling cone and then allowing the solids to settle by gravity for a given length of time. Results are reported either as a volume (mL/L) or a mass (mg/L) concentration.

Sheet Flow

Flow of water that occurs overland in areas where there are no defined channels where the water spreads out over a large area at a uniform depth.

Site**Soil Amendment**

Any material that is added to the soil to change its chemical properties, engineering properties, or erosion resistance that could become mobilized by storm water.

Streets and Utilities Phase

Construction stage including excavation and street paving, lot grading, curbs, gutters and sidewalks, public utilities, public water facilities including fire hydrants, public sanitary sewer systems, storm sewer system and/or other drainage improvements.

Structural Controls

Any structural facility designed and constructed to mitigate the adverse impacts of storm water and urban runoff pollution

Suspended Sediment Concentration (SSC)

The measure of the concentration of suspended solid material in a water sample by measuring the dry weight of all of the solid material from a known volume of a collected water sample. Results are reported in mg/L.

Total Suspended Solids (TSS)

The measure of the suspended solids in a water sample includes inorganic substances, such as soil particles and organic substances, such as algae,

aquatic plant/animal waste, particles related to industrial/sewage waste, etc. The TSS test measures the concentration of suspended solids in water by measuring the dry weight of a solid material contained in a known volume of a sub-sample of a collected water sample. Results are reported in mg/L.

Toxicity

The adverse response(s) of organisms to chemicals or physical agents ranging from mortality to physiological responses such as impaired reproduction or growth anomalies.

Turbidity

The cloudiness of water quantified by the degree to which light traveling through a water column is scattered by the suspended organic and inorganic particles it contains. The turbidity test is reported in Nephelometric Turbidity Units (NTU) or Jackson Turbidity Units (JTU).

Vertical Construction Phase

The Build out of structures from foundations to roofing, including rough landscaping.

Waters of the United States

Generally refers to surface waters, as defined by the federal Environmental Protection Agency in 40 C.F.R. § 122.2.¹

Water Quality Objectives (WQO)

Water quality objectives are defined in the California Water Code as limits or levels of water quality constituents or characteristics, which are established for the reasonable protection of beneficial uses of water or the prevention of nuisance within a specific area.

¹ The application of the definition of “waters of the United States” may be difficult to determine; there are currently several judicial decisions that create some confusion. If a landowner is unsure whether the discharge must be covered by this General Permit, the landowner may wish to seek legal advice.

APPENDIX 6: Acronym List

ASBS	Areas of Special Biological Significance
ASTM	American Society of Testing and Materials; Standard Test Method for Particle-Size Analysis of Soils
ATS	Active Treatment System
BASMAA	Bay Area Storm water Management Agencies Association
BAT	Best Available Technology Economically Achievable
BCT	Best Conventional Pollutant Control Technology
BMP	Best Management Practices
BOD	Biochemical Oxygen Demand
BPJ	Best Professional Judgment
CAFO	Confined Animal Feeding Operation
CCR	California Code of Regulations
CEQA	California Environmental Quality Act
CFR	Code of Federal Regulations
CGP	NPDES General Permit for Storm Water Discharges Associated with Construction Activities
CIWQS	California Integrated Water Quality System
CKD	Cement Kiln Dust
COC	Chain of Custody
CPESC	Certified Professional in Erosion and Sediment Control
CPSWQ	Certified Professional in Storm Water Quality
CSMP	Construction Site Monitoring Program
CTB	Cement Treated Base
CTR	California Toxics Rule
CWA	Clean Water Act
CWC	California Water Code
CWP	Center for Watershed Protection
DADMAC	Diallyldimethyl-ammonium chloride
DDNR	Delaware Department of Natural Resources
DFG	Department of Fish and Game
DHS	Department of Health Services
DWQ	Division of Water Quality
EC	Electrical Conductivity
ELAP	Environmental Laboratory Accreditation Program
EPA	Environmental Protection Agency
ESA	Environmentally Sensitive Area
ESC	Erosion and Sediment Control
HSPF	Hydrologic Simulation Program Fortran
JTU	Jackson Turbidity Units
LID	Low Impact Development
LOEC	Lowest Observed Effect Concentration
LRP	Legally Responsible Person
LUP	Linear Underground/Overhead Projects

MATC	Maximum	Allowable Threshold Concentration
MDL	Method	Detection Limits
MRR		Monitoring and Reporting Requirements
MS4		Municipal Separate Storm Sewer System
MUSLE		Modified Universal Soil Loss Equation
NAL		Numeric Action Level
NEL		Numeric Effluent Limitation
NICET		National Institute for Certification in Engineering Technologies
NOAA		National Oceanic and Atmospheric Administration
NOEC		No Observed Effect Concentration
NOI		Notice of Intent
NOT		Notice of Termination
NPDES		National Pollutant Discharge Elimination System
NRCS		Natural Resources Conservation Service
NTR		National Toxics Rule
NTU		Nephelometric Turbidity Units
O&M	Operation	and Maintenance
PAC	Polya	luminum chloride
PAM	Polyacryla	mide
PASS	Polya	luminum chloride Silica/sulfate
POC	Pollutants	of Concern
PoP	Probability	of Precipitation
POTW		Publicly Owned Treatment Works
PRDs		Permit Registration Documents
PWS	Planning	Watershed
QAMP		Quality Assurance Management Plan
QA/QC		Quality Assurance/Quality Control
REAP		Rain Event Action Plan
Regional Board		Regional Water Quality Control Board
ROWD		Report of Waste Discharge
RUSLE		Revised Universal Soil Loss Equation
RW	Receiv	ing Water
SMARTS		Storm water Multi Application Reporting and Tracking
System		
SS	Settleable	Solids
SSC		Suspended Sediment Concentration
SUSMP		Standard Urban Storm Water Mitigation Plan
SW	Storm	Water
SWARM		Storm Water Annual Report Module
SWAMP		Surface Water Ambient Monitoring Program
SWMM		Storm Water Management Model
SWMP		Storm Water Management Program
SWPPP		Storm Water Pollution Prevention Plan
TC	Treatment	Control
TDS	Total	Dissolved Solids

TMDL	Total Maximum Daily Load
TSS Total	Suspended Solids
USACOE	U.S. Army Corps of Engineers
USC United	States Code
USEPA	United States Environmental Protection Agency
USGS	United States Geological Survey
WDID Waste	Discharge Identification Number
WDR Waste	Discharge Requirements
WLA Waste	Load Allocation
WET Whole	Effluent Toxicity
WRCC	Western Regional Climate Center
WQBEL	Water Quality Based Effluent Limitation
WQO Water	Quality Objective
WQS Water	Quality Standard

APPENDIX XXIII
WEATHER TRACKING