

PUBLIC UTILITIES COMMISSION OF THE STATE OF CALIFORNIA

SAFETY DIVISION
UTILITIES SAFETY

RESOLUTION SU-5
BRANCH May 22, 1990

RESOLUTION SU-5, ORDER AUTHORIZING
RULE CHANGES TO GENERAL ORDER NO. 95 (G .O. 95)
RULES FOR OVERHEAD ELECTRIC LINE CONSTRUCTION

SUMMARY

1. The staff of the Safety Division's utilities Safety Branch requests authorization for changes to G.O.95 contained in the enclosed Appendix A.
2. The request follows submittal of proposed changes by the General Orders 95/128 Rules Committee composed of representatives from operators of electric and communications lines in California. The committee has obtained a consensus of investor owned utilities, utility districts, municipalities, California Cable Television Association and the associated labor unions concerning the changes.
3. The changes authorized are to rules concerning climbing and working space on poles, high voltage marking, definitions of terms, equipment and conductor clearances, and terminals.

BACKGROUND

1. The changes are the result of informal proposals by the General Orders 95/128 Rules Committee. The committee represents operators of overhead and underground lines and the associated labor unions in California. It was formed by the line operators to review electric and communication line construction and maintenance methods and materials. All operators are invited to participate in ongoing workshops held in numerous locations each year to consider state-of-the-art methods and materials for the industry, along with changes in the General Orders.
2. Members of the Commission's Utilities Safety Branch staff attend meetings of the rules committee and its subcommittees to participate in its discussions and assist in its work.
3. When a study group or subcommittee of the "Rules Committee" drafts a rule change proposal, the draft is sent to the whole committee for evaluation. The proposal may be modified to obtain a consensus of the committee; if consensus is not reached, the proposal is dropped.

4. After a final draft of proposed rule changes is approved, in committee meetings the draft is mailed with a ballot to all members so that those who may have missed any discussion sessions may review and vote on each change. Any dissenting vote requires that meetings be held to resolve the issues.
5. Safety is a primary concern when a rule change is proposed. As noted in the rationale for changes in Appendix A, safety to workers and the general public is considered.

DISCUSSION

1. The proposed rule changes are presented in the enclosed Appendix A. A list of the rules divided into three groups is contained in the Table of Contents of Appendix A.
2. To assist in analyzing the changes the existing rule is shown with the lines numbered, in most cases, followed by the proposed rule which, in turn, is then followed by the rationale explaining the change.
3. Where a pictorial representation is part of the rule it has been taken from the appendix at the end of G.O.95 and moved into the text of the rule. This should lend clarity and aid in the interpretation of the rules. Eighteen of the drawings in Appendix G of G.O.95 have been deleted; they were merged, simplified or otherwise revised as they were moved into the text.
4. The staff believes the changes provide for increased safety to workers and the general public; the changes incorporate state-of-the-art methods and materials and should provide for economical construction and maintenance. The Safety Division staff recommends authorization of the changes.

FINDINGS

1. We find that the changes to G.O.95 authorized in this, Resolution are just and reasonable.

IT IS ORDERED that:

1. The changes in text shown in Appendix A shall be made in G.O.95.
2. All rules changed shall be marked "Revised May 22, 1990, by Resolution SU-5"
3. This Resolution is effective today.

I hereby certify that this Resolution was adopted by the Public Utilities Commission at its regular meeting on May 22, 1990. The following Commissioner approved it.

G. MITCHELL WILK

President

STANLEY W. HULETT

JOHN B. CHANIAN

PATRICIA M. ECKERT

Commissioners

Commissioner Frederick R. Duba, being necessarily absent, did not participate.

APPENDIX A
PROPOSED RULE CHANGES
RULES FOR OVERHEAD ELECTRIC LINE CONSTRUCTION
GENERAL ORDER NO. 95

STATE OF CALIFORNIA PUBLIC UTILITIES COMMISSION

- Notes: 1) Each Change is presented by giving the existing rule, the proposed rule and associated rule changes followed by the rationale for the proposed changes.
- 2) The Changes are divided generically into three groups:
- I -CLIMBING SPACE
 - II -HIGH VOLTAGE MARKING
 - III -DEFINITIONS, CLEARANCES, CONDUCTORS, TERMINALS, AND CLIMBING AND WORKING SPACE

APPENDIX A – TABLE OF CONTENTS

GROUP I – CLIMBING SPACE

Existing Rule 54.7-A Climbing and Working Space

Existing Rule 54.11-F Climbing Space

Proposed 54.7-A Climbing and Working Space

Proposed Rule 54.11-F Climbing Space

ASSOCIATED RULE CHANGES (With Climbing Space Rules)

Rule 20.6 Climbing Space (Definition)

Rule 52.7-D Separation from Metal Pins and Dead-End Hardware

Rule 54.4-D1 Center Line Clearance

Rule 84.7 Climbing Space

Rule 93 Climbing Space

Delete Figures from Appendix G, G.O. 95

Rationale for Changes - Climbing and Working Space Rules

GROUP II - HIGH VOLTAGE MARKING

Existing Rule 51.6 Marking and Guarding

Existing Rule 52.4 Marking

Proposed Rule 51.6 Marking and Guarding

Proposed Rule 52.4 Marking

Rationale for Changes – Marking Requirements Rules 51.6-A & 52.4

GROUP III –DEFINITIONS, CLEARANCES, CONDUCTORS, TERMINALS. AND CLIMBING AND WORKING SPACE

Proposed Rule 21.4-Insulated (Definition) New Rule

Rationale for Proposed Rule 21.4

Proposed Rule 21.5-Isolated (Definition) New Rule

Rationale for proposed Rule 21.5

Associated Rule Changes (With Rules 21.4 and 21.5)

Existing Rule 38 Minimum Clearances of wires From Other wires

Proposed Rule 38 Minimum Clearances of Wires From Other wires

Rationale for Changes to Rule 38

Existing Rule 54.4-C1c (Clearances) Triangular and vertical Configuration

Proposed Rule 54.4-C1c (Clearances) Triangular and vertical Configuration on Different Crossarms on the Same Pole

Associated Change (With Rule 54.4-C1C)

Rationale for Changes to Rule 54.4-C1c

Existing Rule 54.4-D8 (Clearances) At Top of Pole

Proposed Rule 54.4-D8 At Top of pole

Rationale for Changes to Rule 54.4-D8

ASSOCIATED RULE CHANGES (With clearance Rule 54.4-D8)

Existing Rule 58.3d (Transformer clearance) From 750-7,500 Volt
Conductors Above

Proposed Rule 58.3-B3d

Existing Rule 58.3-B3e (Transformer clearance) From 7,500-22,500 Volt
Conductors Above

Proposed Rule 58.3-B3e

Rationale for Changes to Rules 58.3-B3d and e

Existing Rule 54.6-C2 Conductors of 0-750 Volts (Lateral)

Proposed Rule 54.6-C2 Conductors of 0-750 Volts (Lateral)

Rationale for Change to Rule 54.6-C2

ASSOCIATED RULE CHANGE (With Rule 54.6-C2)

Existing Rule 22.2-C Plastic Pipe

Proposed Rule 22.2-C Plastic Pipe

Existing Rule 54.6-F Terminals of Encased Risers and Runs (paragraph 3 only)

Proposed Rule 54.6-F 45 Associated Change (With Rule 54.6-F): Delete Fig.61,
App. G

Rationale for Change to Rule 54.6-F

Existing Rule 59.7-B1 Dimensions of Working Space

Proposed Rule 54.7-B1

Rationale for Change to Rule 54.7-B1

Existing Rule 54.7-B2 Allowable Obstructions to working Space

Proposed Rule 54.7-B2

Rationale, for Change to Rule 54.7-B2

Existing Rule 58.5-D Climbing and Working Space

Proposed Rule 58.5-D

Associated Rule Change (With Rule 58.5-D): Rule 54.7-A3

Rationale for Change to Rule 58.5-D

APPENDIX A

GROUP I - CLIMBING SPACE

EXISTING RULE 54.7 CLIMBING AND WORKING SPACE

A Climbing Space

Climbing space, measured from centerline of pole, shall be provided on one side or in one quadrant of all poles or structures, with dimensions as specified in Rules 54.7-A1, 54.7-A2 and 54.7-A3. For climbing space dimensions where post insulators are utilized see Rule 54.11-F.

The climbing space shall be maintained in the same position for a distance of not less than 4 feet vertically both above and below each conductor level through which it passes. Compliance with this requirement necessitates that the position of the climbing space shall not be changed through conductor levels which are less than 4 feet apart. Where the vertical distance between consecutive conductor levels is 4 feet or more, and less than 8 feet the position of the climbing space through such consecutive levels may be shifted not more than one-quarter of the distance around the pole. Where a conductor is installed at the top of a pole under the provisions of Rule 54.4-D8, the climbing space shall extend up to the level of such pole-top conductor but need not be provided through and above such level.

Allowable obstruction of these climbing spaces, where necessary, are specified in Rule 54.7-A4

This Rule 54.7-A need not apply to non-climbable metal poles in partial underground distribution, provided the regular written operating rules of the utility concerned specify that all work on conductors and equipment supported by such poles shall be performed only from aerial lifts and

(1) in the case of primary conductors, shall be done with live-line tools after installing adequate insulating and protective devices or barriers in order to

(a) prevent accidental contact by the workman with the energized conductors other than the conductor being worked on and

(b) to minimize the possibility of simultaneous contact of the metal parts of live-line tools with the grounded pole and the energized conductor and

(2) in the case of secondary conductors shall be done after suitably covering all energized primary conductors with adequate insulating and protective devices or barriers.

1 Dimensions Where Crossarms are Not Involved: Climbing space through the levels of conductors deadended on poles in vertical configuration shall be a square of the horizontal dimensions tabulated below; and one side of such climbing space shall be bounded by the vertical plane of the dead-ended conductors with the centerline of pole bisecting such side (see App. G, Fig, 15)

| Voltage of Conductors | Dimensions of Square |
|------------------------|---|
| 750-7500 volts | 30 inches |
| 7500-46,000 volts | 36 inches |
| More than 46,000 volts | 36 inches plus 1/2 inch Per kV in excess Of 46kV. |

For climbing space dimensions for low voltage rack construction see Rule 54.9-F.

2 Dimensions Where Line Arms Only Are Involved: The climbing space through levels where line arms without related buck arms are present on poles or structures shall be on one side or face of the pole, with the center line of pole approximately midway on one side of the climbing space (see App. G Fig. 16), and shall have the following dimensions:

For conductors of 0-7500 volts, the climbing space shall be not less than 30 inches square except that for combination arm construction the climbing space shall be not less than 36 inches square. (see Rule 54.8-E for additional requirements where service drops from combination line arms are involved.)

For conductors of 750-46,000 volts the climbing space shall not be less than 36 inches square.

For conductors of more than 46,000 volts the climbing space shall be a square the sides of which shall be not less than 36 inches plus 1/2 inch per kV in excess of 46 kV.

The above dimensions may be reduced not more than 2 percent because of line angles.

The climbing space required by this rule may be shifted laterally not more than 5 inches under the condition that (a) the mid-point of the side of the climbing space coinciding with the center line of, the pole shall be not more than 5 inches from the center line of the pole, and (b) that full climbing space

dimensions shall be maintained, but without the use of the 2% reduction where the shift is more than 2 inches.

3 Dimensions Where Buck Arms Are Involved: The climbing space where line arms and related buck arms are involved on pole or structures shall be in a quadrant and shall have at least the dimensions, determined according to voltage classification as given below. These dimensions are based on the minimum clearance from center line of pole (Table 1, Case 8) and minimum pin spacings (Table 2, Case 15) for the voltages involved, with the pin position numbered outward from the pole on the climbing side.

Where metal back braces are used they shall be considered as one of the arms of double arm construction.

a) For Conductors of 0-750 Volts: Where single line arm and buck arm construction is involved and the climbing space is left open opposite the single arm, the No. 1 pin Position shall be left vacant in the single arm. (See App G, Fig 18.)

Where double line arm and double buck arm construction is involved, the No. 1 pin position shall be left vacant in each arm. (see App. G, Fig. 19)

b) For conductors of More than 750 Volts: Where single arm and single buck arm construction is involved and the climbing space is left open on the opposite side of the pole from the arms, the No. 1 pin position shall be left vacant in both line arm and buck arm (see App. G, Fig. 20). As an alternative, where the conductors are of 750-7500 volts, the No. 1 and No. 2 pin positions in one arm may be left vacant provided the arms involved are in top positions on the pole.

Where double line arm and single buck arm, or vice versa, construction is involved and the climbing space is left open on the side of the pole opposite the single arm, the No. 1 pin position shall be left vacant in both line arm and buck arm (see App. G, Fig. 21). AS an alternative, where the conductors are of 750-7500 volts the No. 1 and No. 2 pin positions may be left vacant in the single arm provided the arm involved are in top positions on the pole.

Where double line arm and double buck arm construction is involved the No. 1 pin position shall be left vacant in one double arm and the No. 1 and No. 2 pin positions shall be left vacant in the other double arm. (See App. G, Fig 22.)

Where a single circuit of more than 7,500 volts is in horizontal configuration at the top of the pole, climbing space has to be provided only up to and not through the top level and the No. 1 pin position need not be left vacant.

c) For Combination Arm Construction with Line Arm and Line Buck Arm or Service Buck Arm: (See Rule 54.8-E for additional requirements where service drops are involved.)

Where the vertical separation between conductor levels on line and buck arms is not less than 4 feet and the climbing space is in a 0-750 volt quadrant, the climbing space dimensions shall be not less than those prescribed in Rule 54.7-A3a for 0-750 volt conductors provided that the required vacant pin conductors provided that the required vacant pin spaces shall be in addition to the 36-inch horizontal conductor separation required in Rule 54.4-C2b. (See App. G, Figs 23, 24 and 25.)

Where the vertical separation between conductor levels on line and buck arms is not less than 4 feet and the climbing space is in a 750-7500 volt conductors provided that the required vacant volt conductors provided that the required vacant pin spaces shall be in addition to the 36-inch horizontal conductor separation required in Rule 54.4-C2b. (See App. G, Figs 26, 27 and 28.)

Where the vertical separation between conductor levels the vertical separation between conductor levels on line and buck arms is less than 4 feet such separation shall not be less than 2 feet and the climbing space dimensions, in any quadrant, shall be not less than those prescribed in Rule 54.7-A3b for 750-7500 volt conductors, provided that the required vacant pin spaces shall be in addition to the 42-inch horizontal conductor separation required in Rule 54.4-C2b. (See App. G Figs 29, 30 and 31.)

d) Alternatives: Where a single line arm or single buck arm is involved and it is impractical to locate the climbing space in the quadrant on the opposite side of the pole from the single arm, it may be located in another quadrant provided that any single arm or arms within the climbing space shall be treated as a double arm.

In applying the pin position spacings as prescribed in Rule 54.7 not less than the minimum spacings of Table 2, Case 15 shall be used. In the event the crossarms used are not bored for the minimum spacings, a spacing of conductors to give equivalent dimensions will be considered as meeting the requirements.

4 Allowable Climbing Space Obstructions: Crossarms and their supporting members are allowed in climbing spaces provided that, where buck arms are involved, any arms within climbing spaces are treated as double arms.

Suitably protected vertical conductors attached to the surfaces of poles, and guys, (except those guys contacting metal pins or dead-end hardware as specified in Rule 52.7-D) are allowed in climbing spaces provided that not more than two guys (provided they are separated at the pole by a vertical distance of not more than 18 inches) and one vertical riser, run, or ground wire are installed in any 4-foot vertical section of climbing space. The terminals or terminal fittings of risers or runs shall not be installed within climbing spaces.

Insulators which support line conductors of 22,500 volts or less may extend not more than one-half of their diameter into the climbing space. Dead-end or strain type insulators which support line conductors of 0-750 volts may extend not more than one-half of their diameter into the climbing space.

Bolts bonded to or used for the attachment of dead-end hardware of a circuit of any voltage in horizontal (wood crossarm) configuration may project into the climbing space provided they are covered with a suitable non-conducting material as specified in Rule 22.2-F. If such bolts are bonded, a positive electrical contact shall be made.

The covering of bolts, required by this rule , shall not apply to:

- (1) Bolts associated with circuits of 0 to 750 volts at any level on a pole or structure.
- (2) Bolts associated with circuits of more than 7,500 volts when located at the top level of a pole.

No part of any guy contacting or connected to a metal pin or part of dead-end hardware, shall be located in the climbing space.

Existing Rule 54.11-F

F. CLIMBING SPACE

(1) One Vertical Circuit at Pole Top: For a single circuit at the top of the pole, the climbing space shall be maintained to the lowest conductor on the climbing side of the pole and workmen shall not go above the lowest conductor level, EXCEPT:

(a) When Conductors Are Moved Out From Pole by accepted "hotline" techniques, or

(b) When the Pole Top Circuit Is De-energized and grounded, the climbing space shall be maintained to the top conductor of the circuit and the climbing space shall not be less than 30 inches square.

(2) Two Vertical Circuits at Pole Top: When two vertical circuits are installed at the top of pole, the climbing space shall be maintained to the lowest conductor level of those circuits on the climbing side of the pole and workmen shall not go above such lowest conductor level, EXCEPT:

(a) When Conductors Are Moved Out From Pole by accepted "hotline" techniques, or

(b) When Both Circuits Are De-energized and grounded the climbing space shall be maintained to the top conductors of the circuits. The space shall not be less than 30 inches square.

(c) When One Circuit Is De-energized and grounded, the climbing space shall be maintained on the climbing side between the center line of the pole and the de-energized conductors. The space shall be not less than 36 inches square.

(3) Vertical Circuits Bonded Together: When vertical circuits are bonded together, regardless of location on the pole, the climbing space shall be maintained to the lowest conductor level of those circuits on the climbing side of the pole and workmen shall not go above such lowest conductor level, unless conductors are moved out from pole by accepted "hotline" techniques, or EXCEPT:

(a) Where a Single Circuit is Involved and such circuit is de-energized and the bond and the de-energized circuit is grounded as required in Rule 53.4-A3b, the climbing space shall not be less than 36 inches and shall be maintained

for a vertical distance of not less than 4 feet below the lowest conductor and not less than 4 feet above the top conductor when not at the top of pole.

(b) Where Two Circuits Are Involved:

1. When Both Circuits Are De-energized and commonly bonded and the bond and the circuits grounded as required in Rule 53.4-A3b, the climbing space shall be maintained to the top conductors of the circuits. The space shall not be less than 36 inches square and shall be maintained for a vertical distance of not less than 4 feet below the lowest conductor and not less than 4 feet above the top conductor when not at the top of pole.

2. When One Circuit Is De-energized and both circuits are commonly bonded and the bond and the de-energized circuit grounded as required in Rule 53.4-A3b, the climbing space shall be maintained on the climbing side between the center line of the pole and the de-energized conductors. The space shall not be less than 36 inches square, and shall be maintained for a vertical distance of not less than 4 feet below the lowest conductor and not less than 4 feet above the top conductor when not at the top of pole.

(4) Unbonded Circuits Below Pole Top: For unbonded circuits below the pole top position climbing space shall be maintained through the levels of conductors supported on post insulators for a vertical distance of not less than four feet above the top conductor and not less than four feet below the lowest conductor.

The climbing space shall be a square of horizontal dimensions tabulated below and one side of the climbing space shall pass through the center line of the pole.

| Voltage of Conductor | Dimensions of Square |
|------------------------|--|
| 750-7,500 volts : | 36" |
| 7,500-46,000 volts | 42" |
| More than 46,000 volts | 42" plus 1/2 " per kV in excess of 46 kV |

G ALLOWABLE CLIMBING SPACE OBSTRUCTIONS

Insulators and their attaching brackets which support line conductors of over 750 volts may extend not more than one-half of their dimension into the climbing space.

Suitable protected vertical conductors attached to the surface of poles and guys (except those guys contacting metal pins or dead-end hardware (as specified in Rule 52.7D)) are allowed in the climbing spaces provided that not more than two guys (provided they are separated at the pole by a vertical distance of not more than 18 inches) and one vertical riser, run, or ground wire are installed in any 4-foot vertical section of climbing space. The terminals or terminal fittings of risers or runs shall not be installed within climbing spaces.

PROPOSED RULE 54.7 CLIMBING AND WORKING SPACE

A. Climbing Space

Climbing space shall be maintained from the ground level. The climbing space shall be maintained in the same position for a distance of not less than 4 feet vertically both above and below each conductor level through which it passes. To comply with this requirement the position of the climbing space shall not be changed through conductor levels which are less than 4 feet apart. Where the vertical distance between consecutive conductor levels is 4 feet or more, and less than 8 feet, the position of the climbing space through such consecutive levels may be shifted not more than one-quarter 12 (90 degrees) of the distance around the pole.

Where a single level of circuitry is installed at the top of a pole, the climbing space shall extend up to the level of such pole-top circuitry and need not be provided through and above such level. Where a conductor is installed at the top of a pole under the provisions of Rule 54.4-D8, the climbing space shall extend up to the level of such pole-top conductor but need not be provided through and above such level.

This rule is not applicable to non-climbable poles. See Rule 22.0-D for definition.

Climbing space measured from center line of pole shall be provided on one side or in one quadrant of all poles or structures with dimensions as specified in the following:

| | <u>Rules</u> |
|---|---|
| Wood Crossarm Construction. | 54.7-A 1 & 2 |
| Without Wood Crossarms (More than 750 Volts) | 54-11-F |
| Low Voltage Rack Construction. | 54.9-F |
| Low Voltage Multiconductor Cable w/Bare Neutral Poles Jointly Used. | 54.10-F 84.7 & 93 |
| Allowable Obstructions of These Climbing Spaces | 54.7-A 3 54.9-F 54.11-G 84.7-E |

The climbing space required by this rule may be shifted laterally not more than 5 inches on the condition that the midpoint of the side of the climbing space coinciding with the center line of the pole shall not be more than 5 inches, from the center line of the pole.

The dimensions specified in the above rules may be reduced not more than 2% because of line angles and minor field variations.

(1) **Dimensions Where Line Arms only Are Involved:** The climbing space where line arms without related buck arms are involved on poles or structures shall be on one side or face of the pole, with the center line of pole approximately midway on one side of the climbing space (See Figure 54-1), and shall have the following dimensions:

| Voltage of Conductors | Dimensions of Square |
|-----------------------|--|
| 0-7500 Volts | 30 inches |
| 7500-46000 Volts | 36 inches |
| More than 46000 Volts | 36 inches plus $\frac{1}{2}$ " per kV in excess of 46 kV |

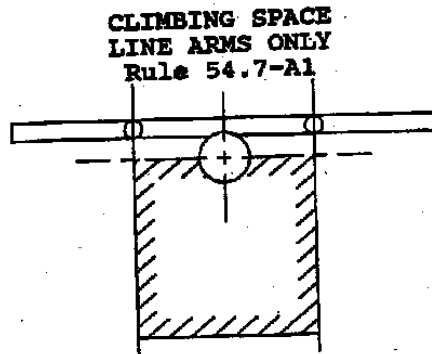

FIGURE 54-1

2) **Dimensions Where Buck Arms Are Involved:** The climbing space where line arms and related buck arms are involved on poles or structures shall be on one side or face of the pole, or in a quadrant as defined below:

(a) Where the Vertical Clearance Between Conductors on Line and Buck Arms is Four Feet or More: The climbing space shall be provided on one side or face of the pole for each arm as specified in Rule 54.7-A1.

(b) Where the Vertical Clearance Between Conductors on Line and Buck Arms is Less Than Four Feet: The climbing space shall be provided through such levels and located in a quadrant and shall have at least the following dimensions (See Figure 54-2.)

| Voltage of Conductors | Dimensions of Square |
|-----------------------|----------------------|
| 0-7500 Volts | 30 inches |
| 7500-35000 Volts | 42 inches\ |

For circuitry located at pole top, the climbing space specified in Rule 54.7-A1 may be applied to the lower arm and up to but not through the conductors on the top arm (see Figure 54-3.).

**CLIMBING SPACE
LINE AND BUCK ARMS
LESS THAN 4-FOOT SEPARATION
Rule 54.7-A2b**

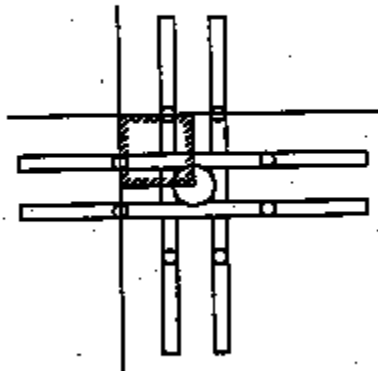

**Below Pole Top
FIGURE 54-2**

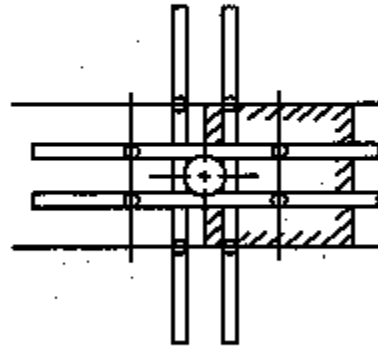

**At Pole Top
FIGURE 54-3**

(c) For Combination Arm Construction With Line and Buck Arms or Service Buck Arm (See Rule 54.8-E for requirements where service drops are involved):

Where the vertical separation between conductor levels on line and buck arms is 4 feet or more, the climbing space shall be provided on one side or face of the pole for each level as specified in Rule 54.7-A1.

Where the vertical separation between conductor levels on line buck arms is less than 4 feet such separation shall not be less than 2 feet, and the climbing space shall not be less than prescribed in Rule 54.7-A2b and the dimensions shall be in accordance with the highest voltage adjacent to the climbing quadrant (See Figure 54-4.).

**CLIMBING SPACE
COMBINATION ARM CONSTRUCTION
LESS THAN 4-FOOT SEPARATION
Rule 54.7-A2c**

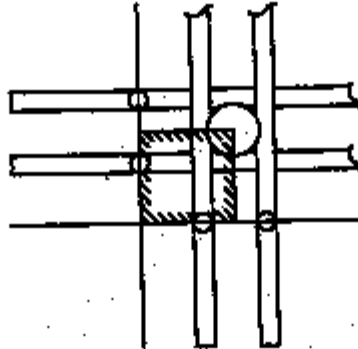

Dimensions of Square:

**0-7500 Volts 30 inches
7500-35000 Volts 42 inches**

**Below Pole Top
FIGURE 54-4**

(3) Allowable Climbing Space Obstructions:

Crossarms and their supporting members are allowed in climbing space. Insulators and their attaching brackets which support line conductors may extend not more than one-half of their diameter into the climbing space.

Suitably protected vertical conductors attached to the surface of poles, and guys (except those guys containing metal pins of dead-end hardware as specified in Rule 52.7-D), are allowed in climbing spaces provided that not more than two guys (provided they are separated at the pole by a vertical distance of not more than 18 inches), and one vertical riser, run, or ground wire are installed in any 4 foot vertical section of climbing space.

Bolts bonded to or used for the attachment of dead-end hardware of a circuit of any voltage in horizontal (wood crossarm) configuration may project into the climbing space provided they are covered with non-conducting material as specified in Rule 22.2-F. If such bolts are bonded, a positive electrical contact shall be made.

The covering of bolts required by this rule shall not apply to:

(a) Bolts associated with circuits of 0 to 750 volts at any level on pole or structure.

(b) Bolts associated with circuits of more than 7500 volts when located at the top level of a pole.

Modifications of these requirements for rack construction are specified in Rule 54.9-F.

PROPOSED RULE 54.11-F

F. Climbing Space

(1) Where Insulators Are in vertical or Horizontal Climbing Position, more than 750 volts: Climbing space shall be maintained through the levels of conductors for a vertical distance of not less than 4 feet above the top conductor and not less than 4 feet below the lowest conductor.

Exception: For a circuit at the top of the pole, the climbing space shall be maintained to the lowest conductor of the circuit on the climbing side of the pole (See Figure 54- 5.).

The climbing space shall be a square of horizontal dimensions tabulated below and one side of the climbing space shall pass through the center line of the pole.

Voltage of Conductors

Dimensions of Square

750-46000 Volts.

36 inches

46000-75000 Volts.

48 inches

More than 75000 Volts.

48 inches plus

1/2" per kV in

excess of 75 kV

**CLIMBING SPACE
INSULATORS IN VERTICAL OR HORIZONTAL
POSITION WITHOUT WOOD CROSSARMS
Rule 54.11-F1**

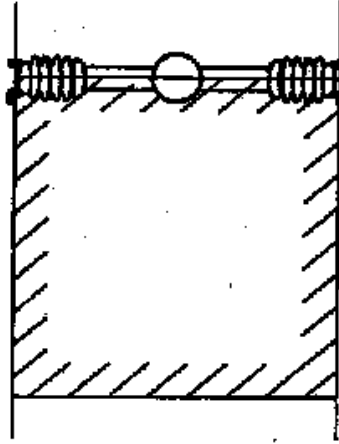

FIGURE 54-5

(2) Dimensions Where Conductors Are Dead-ended In vertical Configuration: Climbing space through conductors shall be a square of the horizontal dimensions tabulated below, and shall be located either on one side or a quadrant of the pole (See Figure 54-6.).

Voltage of Conductors
750-7500 Volts
7500-46000 Volts
More than 46000 Volts

Dimensions of Square
30 inches
36 inches
36 inches plus 1/2"
per kV in excess of
46 kV

CLIMBING SPACE
DEAD ENDING IN VERTICAL CONFIGURATION
RULE 54.11-F2

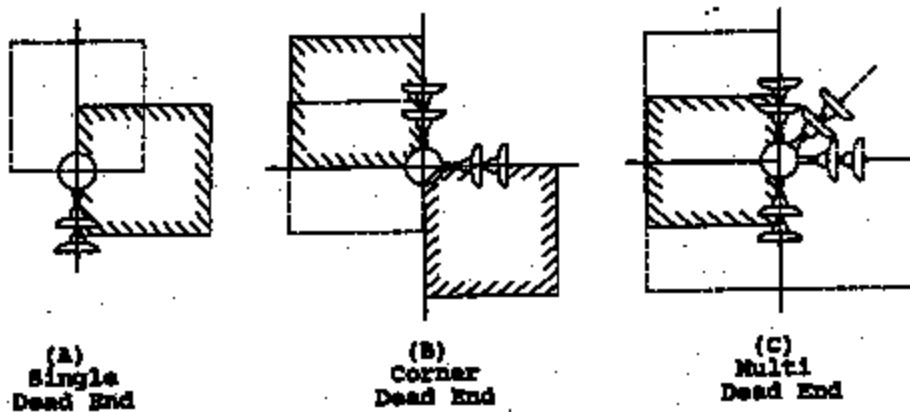

FIGURE 54-6

G. Allowable Climbing Space Obstructions

Insulators and their attaching brackets which support line conductors may extend not more than one-half of their diameter into the climbing space.

Suitably protected vertical conductors attached to the surface of poles, and guys (except those guys contacting metal pins or dead-end hardware as specified in Rule 52.7-D), are allowed in climbing spaces provided that not more than two guys (provided they are separated at the pole by a vertical distance of not more than 18 inches), and one vertical riser, run, or ground wire are installed in any 4 foot vertical section of climbing space.

ASSOCIATED RULE CHANGES
(WITH CLIMBING SPACE RULES)

1. Rule 20.6 Climbing Space

Existing Rule

Climbing space means the space reserved along the surface of a climbable pole or structure to permit ready access for linemen to equipment and conductors located on the pole or structure.

Proposed Rule

Climbing space means the space reserved along the surface of a climbable pole or structure to permit ready access for linemen to equipment and conductors located on the pole or structure. Climbing space shall be maintained from the around level.

NOTE: New material indicated by underlining

2. Rule 52.7-D Separation From Metal pins and Dead-End Hardware

Existing Rule (2nd Paragraph)

Guys and space bolts shall have a clearance of not less than 1-1/2 inches from metal pins and dead-end hardware unless contact is intended, in which case a positive electrical contact shall be made. Any guy contacting or connected to a metal pin or part of dead-end hardware shall not be placed in the climbing space. No part of any guy may be nearer than 1-1/2 inches to any through bolt which is metallically interconnected to dead-end hardware.

Proposed Rule (2nd Paragraph)

Any guy contacting or connected to a metal pin or part of dead-end hardware shall not be placed in the climbing space. No part of any guy may be nearer than 1-1/2 inches to any through bolt which is metallically interconnected to dead-end hardware.

NOTE: The first sentence has been deleted

3. Rule 54.4-D1 Center Line Clearance at Angles in Lines:

Existing Rule

"... reduction of climbing space widths than that specified in Rule 54.7-A2 for line angles."

Proposed Rule

"... reduction of climbing space widths than that specified in Rule 54.7-A for line angles."

NOTE: The "2" has been deleted from 54.7-A2.

4. Rule 84.7 Climbing Space

Existing Rule (3rd Paragraph)

The position of the climbing space shall not be shifted more than 90 degrees around the pole within a vertical distance of less than 8 feet.

Proposed Rule

The position of the climbing space shall not be shifted more than 90 degrees around the pole within a vertical distance of less than 8 feet. Climbing space shall be maintained from the around level.

NOTE: New material indicated by underlining.

5. Rule 93 Climbing Space

Existing Rule

Climbing space shall be provided on all jointly used poles which support conductors and the provisions of Rule 54.7 and 84.7 are directly applicable to such poles. Climbing space on jointly used poles shall be so correlated between conductor levels that its position in relation to the pole is not changed by more than 90 degrees in a vertical distance of less than 8 feet.

Proposed Rule

Climbing space shall be provided on all jointly used poles which support conductors and the provisions of Rule 54.7 and 84.7 are directly applicable to such poles. Climbing space on jointly used poles shall be so correlated between conductor levels that its position in relation to the pole is not changed by more than 90 degrees in a vertical distance of less than 8 feet. Climbing space shall be maintained from the ground level.

NOTE: New material indicated by underlining.

6. Delete the following figures from Appendix G, G.O. 95:

FIGURE

- | | |
|----------|--|
| 15 | Climbing Space for Dead End in Vertical Configuration, Rule 54.7-A1 |
| 16 | Climbing Space, Line Arms Only, Rule 54.7-7-A2 |
| 17,18,19 | Climbing Space, Line and Related Volt Conductors, Rule 54.7-A3a |
| 20,21,22 | Climbing Space, Line and Related Buck-arm, 750- 22,500 Volt Conductors, Rule 54.7-A3b |
| 23,24,25 | Climbing Space for Combination Arm Construction, 0-750 Volt Quadrant, Rule 54.7-A3c |
| 26,27,28 | Climbing Space for Combination Arm Construction 750-7500 Volt Quadrant, Rule 54.7-A3c |
| 29,30,31 | Climbing Space for Combination Arm Construction 0-750 or 750-7500 Volt Quadrant, Rule 54.7-A3c |

RATIONALE FOR CHANGES
CLIMBING AND WORKING SPACE RULES

NEW LINE 2

A clarifying sentence is added to the opening paragraph, requiring climbing space to originate from the ground level rather than four (4) feet below the lowest conductor level.

Climbing space from the ground level to four (4) feet below the lowest conductor level has not been specifically defined. The number, size, and location of risers and equipment shall be limited to assure adequate access.

Problems have been experienced in the past because the requirement for climbing space has only been related to conductor levels. This has resulted in situations where there has been a lack of climbing space extending from ground level.

NEW LINES 3 THROUGH 12

The remainder of the first paragraph reflects language currently found in existing lines 7 through 16.

NEW LINES 13 THROUGH 19

This portion of the rule allows the termination of climbing space at the pole top conductor level regardless of voltage or conductor configuration. It restates existing lines 17 through 20 and replaces existing lines 121 through 124 which were limited to circuit voltage of above 7500 volts and buck arm construction configuration.

NEW LINES 20 AND 21

This portion of the rule states that non-climbable poles are not included. The entire portion (existing lines 23 through 39) dealing with work procedures has been deleted.

NEW LINES 22 THROUGH 34

To provide more convenient cross-reference to the climbing space area, this portion of the rule consolidates climbing space reference points to a single page. All other references to other rules containing additional climbing space requirements have been removed from the main body of the text.

NEW LINES 35 THROUGH 39

This is a restatement of old lines 72-76. Sub-section (b) (old lines 76-79) restricting the application of the 2% reduction was deleted. The 2% reduction can be safely applied with all allowable shifts up to and including 5 inches.

NEW LINES 40 THROUGH 42

Old lines 70 and 71 are moved to new lines 40 through 42 so the allowed reduction would apply to all climbing space configurations. Minor variations in field conditions and minor line angles exist in all climbing space configurations, not only when line arms are involved.

NEW LINES 43. THROUGH 48

New line 44 deletes the words -through levels- from existing line 55. The requirement that climbing space extend -through levels- only applies to circuits below pole top under this proposal (reference 54.7-A second paragraph, new lines 13 through 16).

NEW LINES 49 THROUGH 53

Reformats existing dimensions into tabular form for easier reference and application.

NEW LINES 54 THROUGH 57 (Figure 54-1)

This moves the pictorial representation of the rule from the existing Appendix G, Figure 16 to the body of the rule for easier reference.

NEW LINES 58 THROUGH 77

This change modifies the existing horizontal dimensions of line arm and related buck arm climbing spaces and the method by which they are determined.

Presently, the horizontal dimensions of climbing space, as written in General Order No.95 Rule 54.7-A3, are predicated on the basic required conductor clearances from the centerline of pole (Rule 37, Table 1, Case 8), plus the required horizontal separation of line conductors supported on the same crossarm (Rule 38, Table 2, Case 15) and the number of crossarms located in the climbing quadrant (Rule 54.7-A3).

This is not only a difficult and confusing method of determining dimensions of climbing space, it requires various climbing space situations to be

much greater in size than presently necessary. With the inception of OSHA, the present restrictions on approach distances, as required by California Code of Regulation Title 8, Industrial Relations, Section 2940.2, makes the greater climbing space dimensions, presently required by G.O. 95, obsolete.

Workers, performing under these Title 8, High Voltage Electric Safety Orders, can only approach unprotected energized conductors or equipment at a specified distance unless they are insulated from or guarded against accidental electrical contact.

This requirement would make it necessary for climbing spaces to radically increase in size as the voltage increases. The present climbing spaces, prescribed under G.O. 95, were established before the inception of OSHA; therefore, it was necessary to reserve larger climbing spaces and increase them in size with voltage. This provided a means for workers to climb safely through exposed energized conductor levels without having to install insulating protective devices before doing so.

NEW LINES 78 THROUGH 83 (Figures 54-2 and 54-3)

This moves the pictorial representation of the rule from the existing Appendix G, Figures 17 through 22, to the body of the rule for easier reference.

NEW LINES 84 THROUGH 96

This change simplifies climbing space requirements for combination crossarm construction when line and buck arms are involved .

Crossarms, supporting conductors of different voltage classifications, are rarely used in California; however, to be consistent with the proposed climbing space rule changes previously described under new lines 43 through 83, it is necessary to revise the present combination line and buck arm climbing space requirements.

NEW LINES 97 THROUGH 104 (Figure 54-4)

This moves the pictorial representation of the rule from the existing Appendix G, Figures 23 through 31, to the body of the rule for easier reference.

NEW LINES 105 THROUGH 131

Old lines 168 through 203 are replaced by new lines 105 through 131.

Changes to insulator requirements allow for one half the diameter of all insulators regardless of voltage or configuration in the climbing space. This change is consistent with advancements in insulator technology, and OSHA conductor cover requirements (Title 8, C.C.R., H.V.E.S.O. Articles 35 and 36).

New Rule 22.2-F was added in 1988 to eliminate the need for the definition of bolt covers in this rule and elsewhere in the General Order. This is consistent with the existing format of the order. Rule 22.2-F is:

“Bolt covers shall be made of a non-conducting shield or covering having the insulating efficiency and mechanical strength of impregnated fiber not less than 5/16 of an inch thick.”

NEW LINES 132 THROUGH 150

This change is submitted to clarify the rules involving conductors supported on poles or structures without the use of wood crossarms. Rule 54.11 was added to the General Order in 1968 by Decision No.73455. It permitted the use of post type insulators in the vertical and horizontal position without cross arms and supporting conductors of more than 750 volts.

Since the inception of Rule 54.11 in 1968, there has been confusion as to how to apply the climbing space requirements covered under Rule 54.11-F. The climbing space requirements involved work procedures, and work procedures (old lines 204-278) should not be a part of the General Order. As a result, interpretations have differed widely between the various power companies throughout the state.

The intent of this proposed rule change is to 1) simplify the climbing space requirements by removing the corresponding work procedures, and 2) broaden its application by changing the title of the rule to cover the dimensions of climbing space when insulators of all types are mounted in the vertical or horizontal position, or both.

In part, the rationale for new lines 58 through 77 can also be applied for new lines 132 through 150. OSHA safe work clearance limitations supersede the necessity for greater clearances for workers when climbing in proximity to exposed energized conductors and equipment as presently required by the General Order.

NEW LINES 151 THROUGH 155 (Figure 54-5)

This places a pictorial representation of the rule in the body of the rule for easier reference and understanding.

NEW LINES 156 THROUGH 166

Reformat and heading change (old lines 40-51). The reference to climbing space dimensions for low voltage rack construction in Rule 54.9-F in old lines 52-53 was placed in the general section, new line 28. New rule also provides for quadrant climbing space.

NEW LINES 167 THROUGH 173 (Figure 54-6),

This moves the pictorial representation of the rule from the existing Appendix G, Figure 15 to the body of the rule for easier reference. Added second and third pictorial to clarify climbing space requirements.

NEW LINES 58 THROUGH 173

The proposed rules (lines 58-173) provide a safe and simplified method for field application to achieve the necessary climbing space and help to eliminate any misapplication of the rules.

NEW LINES 174 THROUGH 185

Old lines 279 through 292 have been replaced by new lines 174 through 185. Changes to insulator requirements allow for one half the diameter of all insulators regardless of voltage or configuration in the climbing space. This change is consistent with advancements in insulator technology, and OSHA conductor cover requirements (Title 8, C.C.R., H.V.E.S.O Articles 35 and 36).

GROUP II -HIGH VOLTAGE MARKING
EXISTING RULE 51.6 MARKING AND GUARDING

A. MARKING OF POLES WHERE CONDUCTORS ARE NOT ON CROSSARMS ..

Wood or metal poles which support conductors of more than 750 volts in vertical configuration and not on crossarms shall have bands of bright yellow color not less than one foot in width painted around them. The top of such a band shall be neither less than 2 ½ feet nor more than 3 feet below the lowest conductor of each circuit of more than 750 volts so supported.

In lieu of the paint required by this rule, similarly located signs, showing the words "High voltage" in letters not less than 3 inches in height, shall be used. The letters on such signs shall be white on a green or black background, or such signs shall be of weather and corrosion-resisting material with the letters cut out therefrom and clearly legible.

The provisions of this rule, 51.6-A, shall not apply to the marking of poles at the levels of supply circuits of more than 22,500 volts in rural districts.

See Rule 61.6 for the marking of towers.

EXISTING RULE 52.4 MARKING

Crossarms Supporting Conductors of More than 750 volts and arms supporting equipment connected to or containing conductors of more than 750 volts shall be marked, by methods described in Rule 52.4-A, as specified in Rules 52.4-B, 52.4-C and 52.4-D with the exceptions specified in Rule 52.4-E

A Methods

Crossarms which are required by these rules to be marked as high voltage shall be painted a bright yellow color, or in lieu thereof signs showing the words "High Voltage" (or pairs of signs showing the words "High" and "Voltage") in letters not less than 3 inches in height shall be placed on the face or back in exemption by provisions of the following Rules (52.4-B, C, D, and E).

The letters on such signs shall be white on a green or black background or such signs shall be weather and corrosion resisting material with the letters cut out therefrom and clearly legible.

B Crossarms Supporting Conductors of More than 750Volts and No Conductors of 0-750 Volts.

The Crossarms treated in this Rule 52.4-B may also support certain equipment in addition to conductors of more than 750 volts, and when so utilized the provisions of this Rule 52.4-D will also apply.

- 1 In Urban Districts: All crossarms supporting conductors of more than 750 volts in urban districts shall be marked as high voltage, except as provided in Rule 52.4-B3.
- 2 In Rural Districts: Crossarms Supporting only conductors of more than 750 volts in rural districts shall be marked as high voltage in accordance with the following:
 - a) Supporting Conductors of 750-7500 Volts: All crossarms supporting conductors of 750-7500 volts shall be marked as high voltage
 - b) Supporting Conductors of Constant Current Circuits of More Than 750 Volts: All crossarms supporting conductors of constant current circuits of more than 750volts shall be marked as high voltage, except as provided in Rule 52.4-B3
 - c) Supporting Conductors of 7500-22,500 Volts at certain Locations: At All crossings over public thoroughfares and at locations adjacent to structures such as water tanks, windmills and buildings, adjacent to wells, and at similar locations, crossarms supporting conductors of 7500-22,500 volts shall be marked as high voltage.
 - d) Supporting Conductors of More than 750 Volts At or Below the level of Conductors of 7500 Volts or Less: In rural districts, all crossarms supporting conductors of 7500 volts at or below the level of conductors of 7500 volts or less supported on the same structure shall be marked as high voltage.
 - e) Supporting Conductors of 7500-22,500 Volts on the Same Structure With Conductors of 750 Volts or Less: Where, on the same structures in rural districts, crossarms supporting conductors of 7500-22,500 volts are above conductors of

750 volts or less, the crossarm supporting conductors of 7500-22,500 next above the conductors of 750 volts or less shall be marked as high voltage. All crossarms supporting conductors of 7500-22,500 volts on the same structures shall be marked as high voltage.

- 3 On Guarded Metal Poles: On Latticed metal Poles which are guarded with barriers as required in Rule 51.6-B, the following crossarms shall be marked as high voltage:

Crossarms supporting conductors of 750-7500 volts;

Crossarms supporting conductors of 7500-22,500 volts next above the level of conductors of 7500 volts or less;

Crossarms supporting conductors of 7500-22,500 volts below the level of conductors of 7500 or less;

Crossarms supporting any conductor of more than 7500 volts within 15 feet of walls, fire escapes, exits, windows and similar objects.

Where all conductors on a latticed metal pole which is guarded carry more than 7500 volts and the lowest crossarm supporting them is not required to be marked in accordance with the foregoing provisions of this rule , the entire pole shall be marked as high voltage by means of signs placed on any two opposite sides of the pole at a point above the barrier and below the lowest conductor level.

- 4 On Systems Using Combination Arms: On systems where conductors of 0-750 volts and conductors of 750-7500 volts are usually carried on the same crossarms, any crossarms supporting conductors of 750-7500 volts on both sides of a pole shall be marked as high voltage on both portions to show that the entire crossarm carries high voltage conductors.

C Crossarms Supporting Conductors of 750-7500 Volts and Conductors of 750 Volts or Less. (Combination Arms)

- 1 High Voltage markings: Combination arms shall be marked as high voltage on the portions supporting conductors of 750-7500 volts. Where paintings is used as the method of marking on such portions of combination arms, the painting shall extend from the ends of the

arms to the center line of the pole, or to a position approximately midway between the nearest conductors of different voltage classifications on alley arms or bridge arms.

- 2 Making of Conductors of 750 Volts or Less: On systems where the use of combination arms is so unusual that the requirements of Rule 52.4-B4 are not applied, all combination arms shall be marked as high voltage as specified in Rule 52.4-C1 and in addition thereto a readily legible designation shall be placed on the portions supporting conductors of 750 volts or less. Such designation shall read "0-750 Volts" or shall indicate the nominal voltage of the circuits of 750 volts or less and shall not read "Low Voltage"

The requirements of this rule do not apply to conductor supporting timbers on transformer structures on systems where no other combination arms are used.

D Crossarms Supporting Miscellaneous Equipment

Included in this group are supporting transformers, cutouts, regulators, oil switches, air switches, capacitors, series controllers, and similar apparatus which are connected to or are a part of the circuit in excess of 750 volts. These arms shall be marked in accordance with methods specified in Rule 52.4-A

- 1 Hanger Arms, Cutout Arms, Etc: Where yellow paint is used as the method of marking, such arms shall be fully painted except as provided in Rule 52.4-C1

Where high voltage signs are used as the method of marking, they are required on the face toward the climbing space of hanger arms or of arms supporting cutouts, excepting that signs are not required on any arm supporting cutouts only where such cutout arm is within 30 inches vertically from either a line arm or a hanger arm in which is marked as high voltage

Where high voltage signs are used as the method of marking, they are not required on the face away from the climbing space of hanger arms supporting cutouts only or of line arms which are not combination arms and which are used as hanger arms, under any of the following conditions:

Where two or more transformers, regulators, or similar pieces of apparatus are supported on the same arm;

Where one or more transformers and one or more oil switches or air switches are supported on the same arm;

Where one or more constant current transformers or regulators and the accompanying series controller are supported on the same arm;

Where one transformer and one or more primary cutouts used in connection therewith are supported on the same arm, providing the conductors leading to these pieces of apparatus are supported on crossarms immediately adjacent thereto (maximum vertical separation of 30 inches) which are marked as high voltage; or

Where a separate arm used to support cutouts only is within 30 inches vertically from either a line arm or a hanger arm which is marked as high voltage.

- 2 Heel Arms: Heel arms, while treated in these rules as supporting high voltage equipment, are not required to be marked as high voltage.

E Exceptions

- 1 Double Arms: Where high voltage signs are used as the method of marking, they are not required on the inside face of double arms.
- 2 Brackets: Where extension brackets or clearance brackets are used to extend or supplement crossarms, and support conductors of more than 750 volts, such supplementary supports are not required to be marked as high voltage.
- 3 METAL POLES: Metal poles with crossarms supporting conductors of more than 750 Volts and which are not easily climbed except by qualified persons, may, in lieu of marking crossarms, be marked in accordance with the provisions of Rule 51.6A.
- 4 METAL CROSSARMS: Where metal crossarms supporting conductors of more than 750 volts are attached to wood or steel poles, the poles may be marked in accordance with the provisions of Rule 51.6A.

PROPOSED RULE 51.6 MARKING AND GUARDING

A. MARKING OF POLES

- 1) Wood or metal poles which support conductors of more than 750 volts shall have high voltage signs in letters not less than 3 inches in height. The top of such signs shall be neither less than 30 inches nor more than 40 inches below the lowest conductor of each circuit of more than 750 volts. Such signs shall be of weather and corrosion-resisting material, solid or with letters cut out therefrom and clearly legible.
- 2) Optional marking methods:
 - a) Similarly located bands of bright yellow color not less than 1 foot in width may be used;
 - b) In lieu of marking the pole, crossarms where present may be marked per Rule 52.4.

PROPOSED RULE 52.4 HIGH VOLTAGE MARKING

A. METHODS

Crossarms required by these rules to be marked shall have a single sign or pair of signs showing the words "HIGH" and "VOLTAGE" in letters not less than 3 inches in height. These signs shall be placed on the face and back of such crossarms, unless exempted by provisions of Rules 52.4-8, C, D and E. Such signs shall be of weather and corrosion-resisting material, solid or with letters cut out therefrom and clearly legible. In lieu of marking the crossarm, Rule 51.6-A may be applied.

B. CROSSARMS SUPPORTING CONDUCTORS OF MORE THAN 750 VOLTS

All crossarms supporting conductors of more than 750 volts shall be marked in accordance with Rule 52.4-A unless modified by Rules 52.4-C, D, and E.

C. COMBINATION CROSSARMS SUPPORTING CONDUCTORS OF MORE THAN 750 VOLTS AND CONDUCTORS OF 750 VOLTS OR LESS

Combination arms shall be marked as high voltage on the portions supporting conductors of more than 750 volts only.

D. CROSSARMS SUPPORTING MISCELLANEOUS EQUIPMENT

Included in this group are crossarms supporting transformers, cutouts, regulators, oil switches, air switches, capacitors, series controllers, and similar apparatus which are connected to or are a part of a circuit of more than 750 volts. These crossarms shall be marked as specified in Rule 52. 4-A.

(1) Hanger Arms, cutout Arms, and similar Apparatus: High Voltage signs are required on the face toward the climbing space of hanger arms or of cross arms supporting cutouts, except that signs are not required on any crossarm supporting cutouts where such cutout arm is within 30 inches vertically from either a line arm or a hanger arm which is marked as high voltage.

(2) Heel Arms: Heel arms, while treated in these Rules as supporting high voltage equipment, are not required to be marked as high voltage.

E. EXCEPTIONS

(1) Double Arms: High voltage signs are not required on 55 the inside faces of double arms.

(2) Brackets: Where extension brackets or clearance 57 brackets are used to extend or supplement crossarms, and support conductors of more than 750 volts, such supplementary 59 supports are not required to be marked as high voltage.

(3) Metal Poles: Metal poles with crossarms supporting conductors of more than 750 volts, may, in lieu of marking crossarms, be marked in accordance with the provisions of Rule 51.6-A.

(4) Metal crossarms: Where metal crossarms supporting 65 conductors of more than 750 volts are attached to wood or metal poles, the poles may be marked in accordance with the provisions of Rule 51.6-A.

RATIONALE FOR CHANGES
MARKING REQUIREMENTS
RULES 51.6-A AND 52.4

The marking requirements for poles and crossarms were evaluated for present application policies, public awareness and worker safety. The attached proposed rules are an attempt to bring the marking requirements into alignment with modern construction techniques.

- | | |
|-----------------|--|
| Rule 51.6-A | The proposed changes to this rule provide for marking of poles whether conductors are on cross arms or not. |
| New Line 2 | The title of the rule is changed to these changes. |
| New Lines 3-5 | Deletes "vertical configuration and not on crossarms" requirement to allow rule to address all poles. Gives priority to the use of High Voltage signs. |
| New Lines 5-7 | Puts both upper and lower limits in inches. Increases the lower limit for placement of warning signs from 3 feet to 40 inches to allow for maintenance of these signs while complying with approach clearances established by Federal and California Occupational Safety and Health regulations. |
| New Lines 8-10 | Proposed rule makes no reference as to color of signs. The present rule allows the use of "cutout" type signs in any color, but limits "solid" type signs to "white on a green or black background". Flexibility of color for solid signs should be allowed as the preference of color combinations change over time (present rule of white on green or black seldom used today). |
| New Lines 11-13 | Removes the word "painted" and allows the use of other types of products which can be applied in many cases more easily and quickly than paint. Other products may also be developed with pre-printed warning statements such as "HIGH VOLTAGE" to increase public warning where necessary. This adjustment would maintain, and in some cases increase public safety. (New types may be introduced under provisions of Rule 15.) |
| New Lines 14-15 | Gives the option of marking the cross arms. |

New Lines 18-20 (Rule 52.4) Painting crossarms to denote high voltage is a practice no longer followed by the majority of electric utilities. Instead, lettered high voltage signs have been universally adopted as a more appropriate and effective means of warning. It is proposed that painting of crossarms be deleted as an option.

New Lines 23-25 The present rule limits color combinations for solid signs only. Signs with cut-out letters are allowed to be any color. Flexibility of color for solid signs should be allowed as the preference of color combinations changes over time (present rule of white on green or black are seldom used today) .

New Line 26 Cross references the two rules addressing marking requirements and allows the option of placing high voltage marking on the pole in lieu of on the crossarms. This method of high voltage marking provides the same level of warning as presently provided in armless construction requirements. See sketches below:

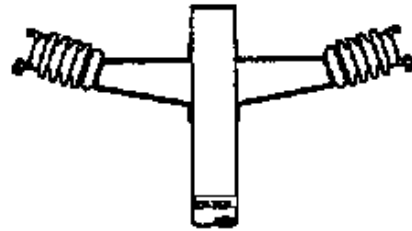
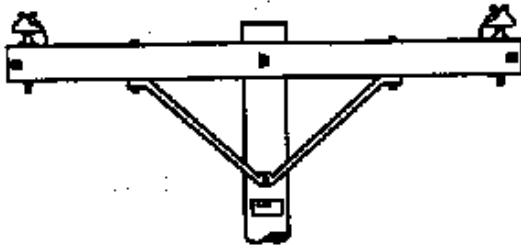

New Lines 29-31 A more concise statement of old lines 21-26. Old lines 42 through 114 have been eliminated since many of the provisions are archaic and rarely used today. This provides for fewer exemptions from high voltage marking requirements.

The rules requiring high voltage marking for combination crossarms supporting conductors of 750 volts or more are simplified. The reference to "low" voltage signs is eliminated.

New Lines 32-52 Restates old lines 148 through 195 and eliminates references to the use of yellow paint.

New Lines 53-67 Restates old lines 196 through 213 with minor word adjustments

GROUP III -DEFINITIONS. CLEARANCES. CONDUCTORS AND CLIMBING AND WORKING SPACE

PROPOSED RULE (DEFINITION)

21.4 Insulated means separated from other conducting surfaces by a dielectric substance (including air-space) offering a high resistance to the passage of current. When an object is said to be insulated, it is understood to be insulated in a suitable manner for the condition to which it is normally subjected.

RATIONALE FOR ADDING RULE

There is no definition in the order for "Insulated" by "air space". The only definition is currently Rule 20.8-G "Insulated Conductors."

The definition in the order, Rule 20.8-G insulated conductors, which are surrounded by an insulating material with dielectric strength sufficient to withstand the maximum difference of potential at normal operating voltages without breakdown or puncture. That definition does not include reference to air space which can also be considered as an insulator.

The National Electric Safety Code (N.E.S.C.) and the State of California High Voltage Electrical Orders (H.V.E.S.O.) both contain this definition of "insulated".

PROPOSED RULE (DEFINITION)

21.5 Isolated means not readily accessible to persons unless special means for access are used.

RATIONALE FOR ADDING RULE

There is no definition in the order for "Isolated"

The N.E.S.C. and the Commission's G.O. 128 both contain this proposed definition of "Isolated." Many times in litigation, the term isolated is referred to and it should be defined in G.O. 95.

ASSOCIATED RULE CHANGES (With Rules 21.4 and 21.5)

Change the following rule numbers:

| | |
|--------------|----------------|
| 21.4 To 21.6 | 21.8 To 21.10 |
| 21.5 To 21.7 | 21.9 To 21.11 |
| 21.6 To 21.8 | 21.10 To 21.12 |
| 21.7 To 21.9 | |

ASSOCIATED RULE CHANGES (With Rules 21.4 and 21.5)

| <u>EXISTING REFERENCE</u> | <u>REFERENCE LOCATION</u> | <u>NEW REFERENCE</u> |
|-------------------------------|--|--------------------------|
| Rule 21.4 | Rule 90 General (Page 256) | Rule 21.6 |
| Rule 21.7 | Rule 51.1 (Page 97) Rule 61.1 (Page 187) Rule 71.1 (Page 197) Rule 81.1 (Page 219) Appendix G Figure 1, 2 & 3 (Pages 328 & 329) | Rule 21.9 |
| Rule 21.9 | Rule 21.3 (Page 29) Rule 54.10 (Page 143) Rule 57.1 (Page 161) Rule 77.1 (Page 202) Rule 87.1 (Page 247) | Rule 21.11 |
| Rule 21.10 | Rule 31.5 (Page 40) Rule 58.3-C3 (Page 173) Rule 91.1 (Page 256) Appendix G Figure 88 (Page 381) | Rule 21.12 |

Index renumbering will be required.

EXISTING RULE 38. MINIMUM CLEARANCES OF WIRES FROM OTHER WIRES

The clearance between any overhead line conductor or wire and any other conductor or wire over which the former crosses, the vertical clearance between wires on different crossarms on the same pole, the horizontal clearance between wires of the same voltage classification on the same crossarm and the clearances of line wires from vertical or lateral conductors or guy wires of the same line or of conflicting lines shall not be less than the values given in Table 2, at a temperature of 60 deg. F. and no wind, except that conductors may be dead-ended at the crossarm or have reduced clearances at points of transposition, and shall not be held in violation of Table 2, Cases 8-15, inclusive.

The clearances of Table 2 shall in no case be reduced more than 10 percent because of temperature and loading as specified in Rule 43 or difference in size or design of the supporting pins, hardware or insulators.

Where conductors, dead ends and metal pins are concerned in any clearance specified in these rules, all clearances of less than 5 inches shall be applicable between the surfaces of conductors (not including tie wires), dead ends, or metal pins, and other conductors, or other objects to which the clearances are applicable.

All clearances of 5 inches or more shall be applicable from the center lines of conductors concerned.

PROPOSED RULE 38. MINIMUM CLEARANCES OF WIRES FROM OTHER WIRES

The minimum vertical, horizontal or radial clearances of wires from other wires shall not be less than the values given in Table 2 and are based on a temperature of 60 F. and no wind. Conductors may be dead-ended at the crossarm or have reduced clearances at points of transposition, and shall not be held in violation of Table 2, Cases 8-15, inclusive.

The clearances in Table 2 shall in no case be reduced more than 10 percent because of temperature and loading as specified in Rule 43 or because of a difference in size or design of the supporting pins, hardware or insulators. All clearances of less than 5 inches shall be applied between surfaces, and clearances of 5 inches or more shall be applied to the center lines of such items.

RATIONALE FOR CHANGES TO RULE 38

The present language for minimum clearances of wires from other wires is confusing. The proposed rule change clarifies and simplifies the language used in Rule 38.

New Lines 2-7 The wire clearance parameters included in the proposed rule are only vertical, horizontal and radial as specified in Table 2.

New Lines 8-14 Specifies that the surface and center line of an item shall be the basis for the clearances of less than 5 inches and 5 inches or more, respectively.

EXISTING RULE 54.4-Clc

(c) Triangular and vertical Configuration: Crossarms used to support conductors of a circuit at different levels (as in triangular or vertical configuration) need not be spaced as in Table 2, Cases 9 to 13, but may be arranged so that the vertical separation of conductors of the same circuit shall be not less than the pin spacings of Table 2, Case 15.

Rule 54.4-DS applies for pole-top triangular construction involving one circuit.

Where circuits are installed in vertical or triangular configuration with vertical conductor separations less than as specified in Table 2, Cases 9 to 13, not more than two circuits shall be installed on the same crossarms and the conductors of both circuits shall be arranged in identical physical configuration on opposite sides of pole except at points of transposition. In the event different voltage classifications are involved, the vertical separation of the conductors shall be not less than the pin spacing for the highest voltage concerned.

PROPOSED RULE 54.4-Clc

(c) Triangular and Vertical configuration on Different Crossarms on the Same Pole: When crossarms are used to support conductors of the same circuit at different levels (as in triangular or vertical configuration), the crossarms may be arranged so that the vertical separation of the conductors of the same circuit shall not be less than the pin spacings of Table 2, Case 15.

Where circuits are installed on cross arms in vertical or triangular configuration with vertical conductor separations less than as specified in Table 2, Cases 9 to 13, not more than two circuits shall be installed on the same crossarms and the conductors of both circuits shall be arranged in identical physical configuration on opposite sides of the pole except at points of transposition. When different voltage classifications are involved, the vertical separation of the conductors shall not be less than the pin spacing for the higher voltage.

For pole-top triangular construction with cross arms involving a single circuit see Rule 54.4-D8.

For pole-top triangular and vertical construction without the use of wood crossarms see Rule 54.11.

ASSOCIATED CHANGE (With Rule 54.4-C1c): Section Contents, 85, Rule 54.4-C1c, after -Configuration- add -On Different Crossarms On the Same Pole-.

RATIONALE FOR CHANGES TO RULE 54.4-C1c

The proposed rule change is to simplify and clarify the present language used in Rule 54.4-C1c. Adds to TITLE, "on Different Crossarms on the Same Pole" after "Configuration", for clarification. Adds a reference to Rule 54.11 for triangular and vertical construction without the use of wood crossarms. Minor changes in structure and wording have been made.

EXISTING RULE 54.4-DB

(8) At Top of Pole:

(a) 0-7,500 Volts in Triangular Configuration: A single conductor of a circuit of 0-7,500 volts may be attached at the top of a pole provided the other conductors of the same circuit are on a crossarm and are not less than 2 feet vertically below the level of such single conductor, except that such a 2-foot vertical separation is not required for dead-ended conductors.

Where this triangular configuration is used, all conductors of other circuits on crossarms on the pole shall be not less than 4 feet below the level of the lower conductors of the pole-top circuit and conductors of 0-750 volts in rack construction shall conform to the requirements of Rule 54.9-E.

(b) More Than 7,500 Volts: A single conductor of a circuit of more than 7,500 volts may be attached directly to the top of a pole or to a crossarm at the top of a pole at a distance less than as specified in Table 1, Case 8, provided no apparatus carried on the pole is connected to the circuit so arranged except lightning arresters, a pole-top switch, or a transformer. Where a transformer is connected to a circuit so arranged, a vertical clearance of not less than 30 inches shall be maintained between the primary conductor directly above and the un-energized metal parts of the transformer, as specified in Rule, 58.3-B3e.

Where this construction is used, all conductors of other circuits on the pole shall be not less than 6 feet below the pole-top conductor except that in rural districts

the conductors of a 0- 750 volt secondary circuit may be not less than 4 feet below the conductor level of such a primary circuit by means of which the secondary is applied.

The dead ending of a conductor at top of pole under these provisions is optional.

PROPOSED RULE 54.4-D8

(8) At Top of Pole:

Clearance Between a Single Conductor and Center Line of Pole: A single conductor of a circuit may be attached directly to the top of a pole or to a crossarm at the top of a pole at a distance less than as specified in Table 1, Case 8. Where a transformer(s) or similar apparatus is connected to a circuit so arranged, a vertical clearance of not less than 30 inches shall be maintained between its un-energized metal parts and the primary conductor directly above.

Where this construction is used, no conductors of other circuits on the pole shall be less than 6 feet below the pole-top conductor.

EXCEPTION: In rural districts this clearance may be reduced to 4 feet when the primary circuit supplies a 0-750 volt circuit below.

For pole-top triangular and vertical construction without the use of wood crossarms see Rule 54.11.

RATIONALE FOR CHANGES TO RULE 54.4-DB

Deletes Rule 54.4D8a and revises 54.4-D8b to form Rule 54.4-D8

Rule 54.4-D8a addresses 0-7,500 volt circuits in triangular configuration with the use of crossarms and places certain restrictions when utilizing this type of construction with current state of the art work methods, tools and equipment these restrictions no longer serve any purpose. Revised Rule 54.4-D8 and present Rule 54.11 will address all items currently addressed in Rule 54.4-D8a.

Rule 54.4-D8b currently addresses a single conductor of more than 7,500 volts at top of pole. It is proposed that Rule 54.4-D8 address all voltages. By deleting (a) and (b) and applying the same rationale to all voltages, the purpose of Rule 54.4-D8 will be simplified and clarified.

Currently (a) allows a single conductor to be attached at the top of the pole provided the other conductors of the same circuit are on a crossarm and not less than 2 feet vertically below the level of such single conductor. By deleting this

restriction and requiring a clearance of not less than 30 inches between the primary conductor directly above and any un-energized part of any apparatus that is connected to a circuit so arranged, the rule will be consistent with the current rules that address triangular construction without the use of wood crossarms.

Currently, (b) restricts apparatus carried on a pole with the conductor configuration described, to lightning arresters, pole top switches or transformers. The order does not place these restrictions on pole top triangular configuration without the use of wood crossarms. with today's state of the art work methods, tools and equipment, this restriction should be removed to allow consistency between this configuration and armless configuration, Rule 54.11. .

Other minor changes in wording and structure are to simplify and clarify Rule 54.4-D8.

ASSOCIATED RULE CHANGES (With clearance Rule 54.4-D8)

EXISTING RULE 58.3-B3d

(d) From 750-7,500 Volt Conductors Above: The clearance between un-energized metal parts of transformers and 750-7,500 volt conductors above or alongside shall be not less than 12 inches vertically or 12 inches horizontally, except that conductors of the circuit to which the transformer is connected may be less than the 12-inch vertical clearance from such un-energized parts but shall be not less than 6 inches vertically from the transformer case and not less than 3 inches radially from the hanger provided no line conductor which is less than 12 inches horizontally from the case or hanger is less than 3 inches (Table 1, Case 9) above the level of the top surface of the crossarm.

PROPOSED RULE 58.3-B3d

(d) From 750-7,500 Volt Conductors Above: The clearance between Unenergized metal parts of transformers and 750-7,500 volt conductors above or alongside shall not be less than 12 inches vertically or 12 inches horizontally, except that conductors of the circuit to which the transformer is connected may be less than the 12-inch vertical clearance from such un-energized parts but shall not be less than 3 inches radially from the hanger provided no line conductor which is less than 12 inches horizontally from the case or hanger is less than 3 inches (Table 1, Case (9) above the level of the top surface of the crossarm.

EXCEPTION: The vertical clearance shall not be less than 30 inches from the conductor at the top of pole as in Rule 54.4-D8.

EXISTING RULE 58.3-B3e

(e) From 7,500-22,500 Volt Conductors Above: The clearance between unenergized metal parts of transformers and 7,500-22,500 volt conductors above shall be not less than 18 inches vertically or 18 inches horizontally except that the vertical clearance shall be not less than 30 inches from a conductor at the top of pole as in Rule 54.4-D8b.

PROPOSED RULE 58.3-B3e

(e) From 7,500-22,500 Volt Conductors Above: The clearance between unenergized metal parts of transformers and 7,500-22,500 volt conductors above shall not be less than 18 inches vertically or 18 inches horizontally.

EXCEPTION: The vertical clearance shall not be less than 30 inches from a conductor at the top of pole as in Rule 54.4-D8.

RATIONALE FOR CHANGES TO 58.3-B3d and e

Rule 58.3-B3d: (Last sentence) Inserts same exception as in Rule 58.3-B3e to cover 750-7,500 volt conductors. Minor wording and structure changes.

Rule 58.3-B3e: Deletes reference to Rule 54.4-DBb and inserts reference to Rule 54.4-DB. Minor wording and structure changes.

EXISTING RULE 54.6-C2

(2) Conductors of 0-750 Volts: Lateral conductors of 0-750 volts may be installed with less than the radial clearances between conductors, specified in Table 2, Cases 16 and 17, and with less than the clearances from the center line and surface of pole, and from the surface of crossarms, as specified in Table 1, Cases 8 and 9, provided such conductors are suitably insulated and placed along the bottom surface of crossarms and are protected by wood moulding or impregnated fiber conduit of thicknesses not less than as specified in Rule 22.2, or are protected by plastic pipe having the properties of the material specified in Rule 22.2-C.

PROPOSED RULE 54.6-C2

(2) Conductors of 0-750 Volts: Lateral conductors of 0-750 volts may be installed with less than the radial clearances between conductors, specified in Table 2, Cases 16 and 17, and with less than the clearance from the center line and surface of pole, and from the surface of crossarm, as specified in Table 1, Cases 8 and 9, provided such conductors are suitably insulated and placed along

the bottom surface of crossarms. Such conductors when installed along the bottom surface of crossarms and protected by plastic pipe having the properties of the material specified in Rule 22.2-C shall be considered to be suitably protected and allowed in the climbing space.

RATIONALE FOR CHANGE TO RULE 54.6-C2

This addition clears up a gray area by allowing PVC pipe to be installed on the bottom surface of a crossarm mounted in the climbing space. Due to changing technology, plastic pipe is now more often used for this type of run. This addition would still meet the requirements of Rule 22.2 definition of suitable materials allowed in the climbing space by allowing the crossarm to be considered to be suitably protecting the lateral run.

ASSOCIATED RULE CHANGE (With Rule 54.6-C2)

EXISTING RULE 22.2-C: PLASTIC PIPE made of rigid unplasticized polyvinyl chloride having the properties and dimensions specified as EPC-40-PVC and EPC-80-PVC in NEMA Standards Publication No. TC2-1978. The plastic pipe herein shall be installed only outside the climbing space on poles or structures.

PROPOSED RULE 22.2-C: PLASTIC PIPE made of rigid unplasticized polyvinyl chloride having the properties and dimensions specified as EPC-40-PVC and EPC-80-PVC in NEMA Standards. The plastic pipe herein specified shall be installed only outside the climbing space on poles or structures unless installed in accordance with Rule 54.6-C2.

NOTE: New material indicated by underlining.

EXISTING RULE 54.6-F TERMINALS OF ENCASED RISERS AND RUNS (PARAGRAPH 3 ONLY)

Cable or conduit bends and the terminals of risers or runs of conductors of more than 750 volts supported on climbable poles or structures shall be arranged with as little exposed surface as practicable but are not required to be covered by a protective covering provided that no portion of the terminal or associated unprotected conductors are within the climbing space or within the clearance from center line of pole specified in Table 1, Case 8 (15 or 18 inches). All exposed grounded surfaces of such terminal fittings and bends of risers and runs shall be not less than 18 inches vertically above the conductor level, and not less than 2 feet radially from any conductor at the next conductor level, of unprotected conductors of another circuit which is entirely below the level of the circuit to which the riser is connected (see App. G. Fig. 61).

PROPOSED RULE 54. 6-F TERMINALS OF ENCASED RISERS AND RUNS
(PARAGRAPH 3 ONLY)

Cable or conduit bends and the terminals of risers or runs of more than 750 volts supported on climbable poles or structures shall be arranged with as little exposed surface as practicable. Such bends or terminals are not required to be covered by a suitable protective covering (see Rule 22.2) provided that no portion of their exposed surfaces or associated unprotected conductors are within the climbing space. For clearance of terminals and their unprotected leads from center line of pole, see Table 1, Case 8. All exposed grounded surfaces of terminal fittings and cables or bends of risers and runs shall be at least 18 inches vertically and 24 inches radially from the next unprotected conductor level below. See Fig. 54-7.

ASSOCIATED CHANGE (WITH RULE 54.6-F)

Delete Fig. 61, App. G titled SUPPLY RISERS AND TERMINALS and add "This page intentionally left blank."

RATIONALE FOR CHANGES TO RULE 54.6-F

The language of paragraph 3 of Rule 54.6-F is being simplified and the reference to Appendix G, Figure 61 changed to Figure 54-7. Appendix G, Figure 61 is being deleted and new Figure 54- 7, an updated diagram of supply risers and terminals, will appear in the text of the rule below paragraph three.

SUPPLY RISERS AND TERMINALS
Rule 54.6-F

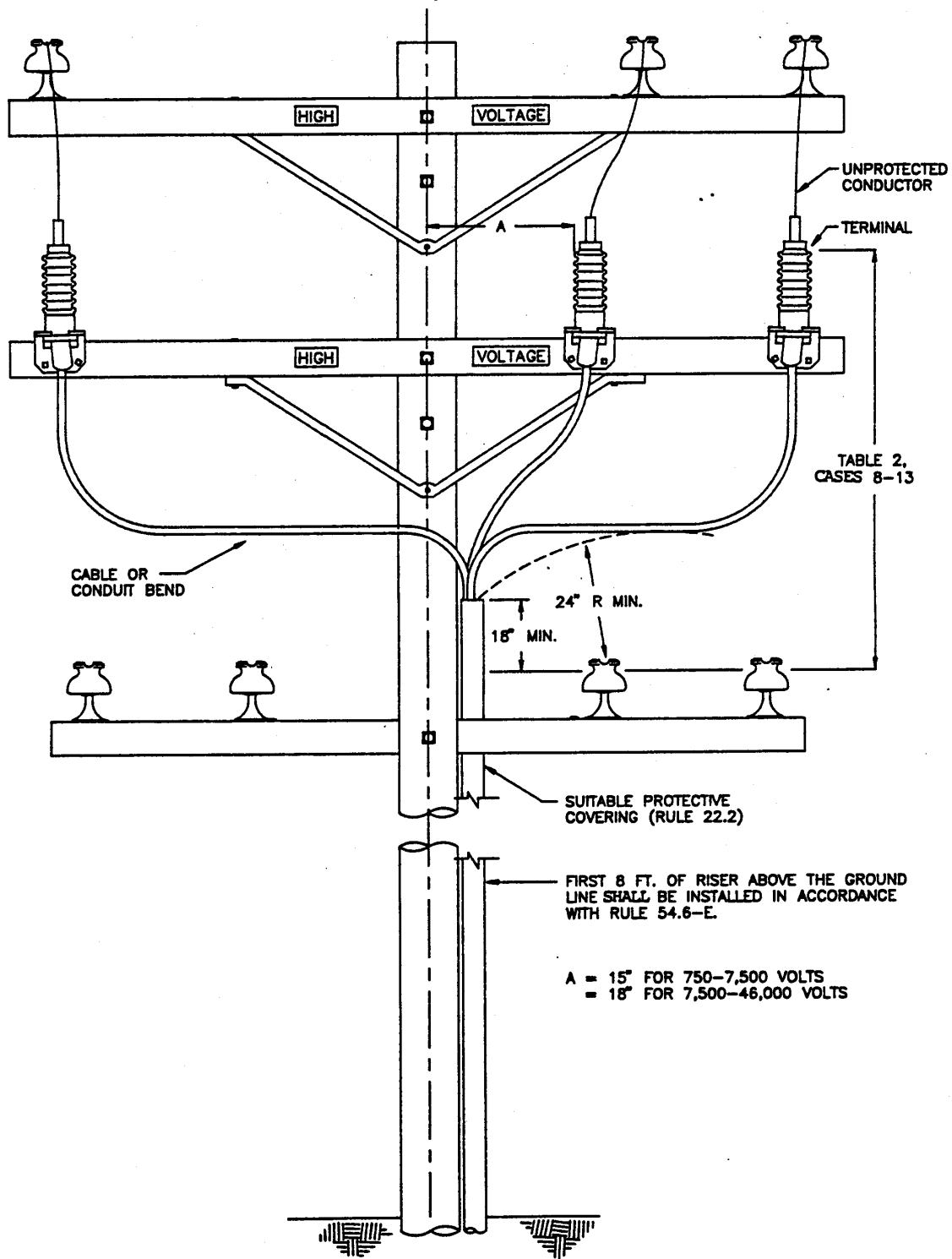

FIG. 54-7

EXISTING RULE 54.7-BI DIMENSIONS OF WORKING SPACE

(1) Dimensions of Working Space: The vertical dimensions of the working space above and below any conductor level shall be equal to the vertical clearances between conductors specified in Table 2, Cases 8 to 14 inclusive, for the voltages involved.

The width of the working space where crossarms are involved shall be the distance between outside pin positions of the crossarms involved. The depth of the working space where crossarms are involved shall be equal to the width of the climbing space and shall be measured perpendicularly from the face of crossarm.

PROPOSED RULE 54.7-BI DIMENSIONS OF WORKING SPACE

(1) Dimensions of Working Space: The vertical dimensions of working space above and below any conductor level shall be equal to the vertical clearances between conductors specified in Table 2, Cases 8 to 14 inclusive, for the voltages involved.

The width of the working space where crossarms are involved shall extend from the climbing space to the outmost conductor position on the crossarm involved. The depth of the working space shall have the same dimension as the climbing space. This dimension shall be measured horizontally from the face of the crossarm. {See Figures 54-8 At B and C.)

The width of the working space where crossarms are not involved (e.g., vertical and triangular construction without crossarms) shall extend from the climbing space to the outmost conductor position on the conductor support involved. The depth of the working space shall have the same dimension as the climbing space and shall be measured from the centerline of pole (See Figure 54- BD). When conductors are located on one side of the pole only (e.g., vertical construction) the dimensions of working space shall be applied as illustrated in Figures 54-BE and F. When climbing space is located in a quadrant, working space shall be applied as illustrated in Figure 54-BG.

RATIONALE FOR CHANGE TO RULE 54. 7-B1

Over the years, overhead line construction has changed to include other types of conductor supports besides crossarms (e.g., metal and fiberglass supports). Presently, Rule 54.7-BI only addresses allowable working space dimensions when crossarms are involved. Working space dimensions for other types of conductor supports, as in armless construction, needs to be addressed. This rule change

will assure that working space is provided for workers above, below, and between conductor levels, regardless of the type of construction.

Illustrations have been added to the text to facilitate the application of working space.

WORKING SPACE
Rule 54.7-B1

WITH CROSSARMS

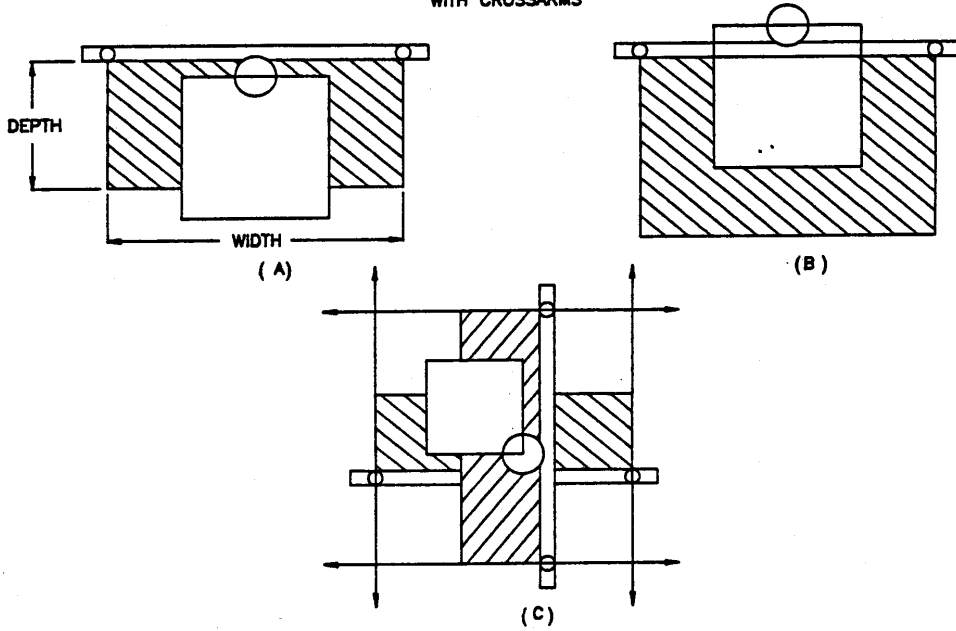

WITHOUT CROSSARMS

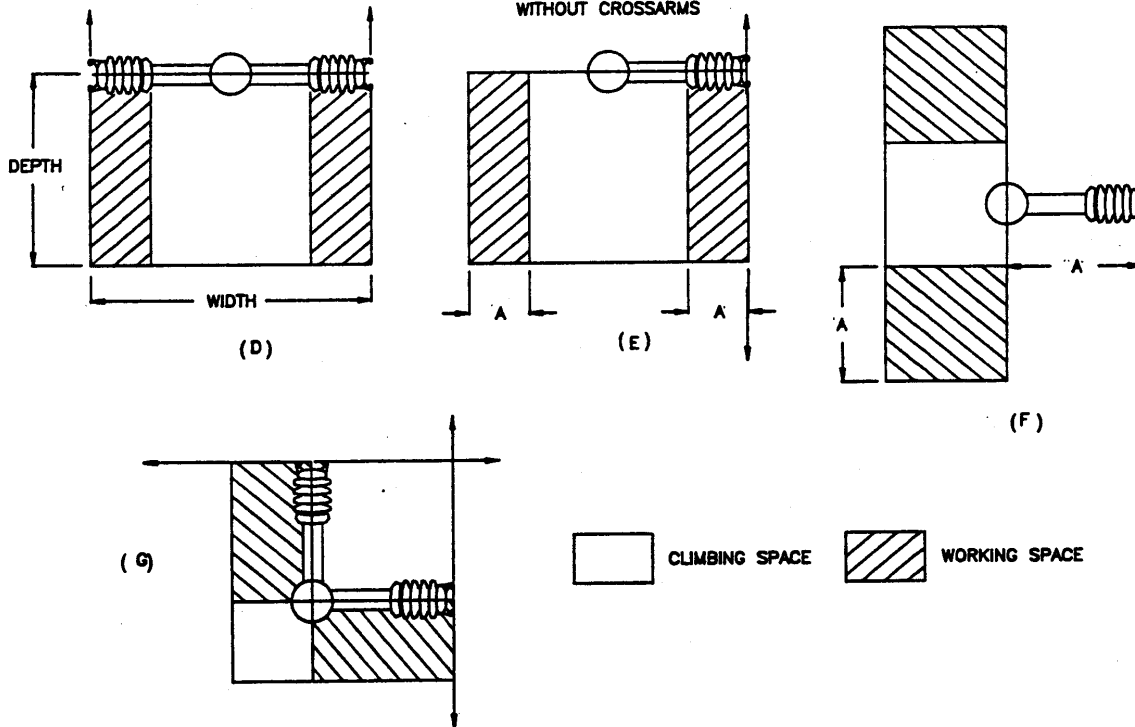

FIGURE 54-8

EXISTING RULE 54. 7-B2 ALLOWABLE WORKING SPACE OBSTRUCTIONS

(2) Allowable Working Space Obstructions: Taps from conductors on line arms to conductors on related buck arms may pass through the working space between the levels of conductors on related line and buck arm.

Service drops of 0-750 volts may pass through the working space of conductors supported on the same crossarm with the drop conductors and may pass through working space of 750-7,500 volt conductors provided not less than the clearance between service drop and line conductors specified in Rule 54.8C6 are maintained cutouts and their leads may be installed in the working space (but not into the climbing space).

Switches and their leads may extend into the working space (but not into the climbing space).

Lead wires to transformers or capacitors may pass through the working space adjacent to the line conductors to which such leads are attached.

Terminal fittings of risers and runs, and their taps, may extend into the working space provided these fittings are the only obstruction of the working space at their level on the same side of the climbing space.

PROPOSED RULE 54.7-B2 ALLOWABLE WORKING SPACE OBSTRUCTIONS

(2) Allowable Working Space Obstructions: Taps from conductors on line arms, or other supports, extending to conductors on related buck arms or other supports, may pass through the working space between such levels of conductors.

(NOTE: No changes to the remainder of the Rule.)

RATIONALE FOR CHANGE TO RULE 54. 7-B2

Over the years, overhead line construction has changed to include other types of conductor supports besides crossarms (e.g., metal and fiberglass supports). Presently Rule 54.7-b2 only addresses allowable working space obstructions when crossarms are involved. Working space obstructions for other types of conductor supports, as in armless construction, needs to be addressed. This rule change includes allowable working space obstructions for all types of construction.

Proposed revisions to lines 1 through 4 only.

EXISTING RULE 58.5-D CLIMBING AND WORKING SPACE

Switches and cutouts shall be so located that, when in either the open or closed position, all energized parts thereof are not less than ~5 or ~8 inches from the centerline of pole as required by Table 1, Case 8, and no part of such equipment shall be in the climbing space. Such apparatus is permitted to be wholly or in part within the working space. The clearances of 15 or 18 inches need not apply to nonfusible pole-top switches connected to a circuit of 7,500 volts or more, provided the switches are installed substantially in the same vertical plane as the conductors to which they are attached, and no climbing space has to be provided through and above the level of such switches.

PROPOSED RULE 58.5-D CLIMBING AND WORKING SPACE

Switches and cutouts shall be so located that, when in either the open or closed position, all energized parts thereof are not less than 15 or 18 inches from the centerline of pole as required by Table 1, Case 8, and no part of such equipment shall be in the climbing space except nonmetallic interphase shafts of gang operated switches and their associated unbonded hardware mounted at the top of the pole. See Figures 58-1 and 58-2. Such apparatus is permitted to be wholly or in part within the working space. The clearance of 15 or 18 inches need not apply to nonfusible pole-top switches provided the switches are installed substantially in the same vertical plane as the conductors to which they are attached, and no climbing space has to be provided through and above the level of such switches.

ASSOCIATED CHANGE (With Rule 58.5-D): Rule 54.7-A3

The last paragraph of Rule 54.7-AJ should be changed as follows:

"Modification of these requirements for rack construction are specified in Rule 54.9-F; for switches. in Rule 58.5-D: and for climbing space without wood crossarms in Rule 54.11-G."

NOTE: Underlined portion is added.

GANG OPERATED SWITCHES
CLIMBING AND WORKING SPACE
Rule 58.5-D

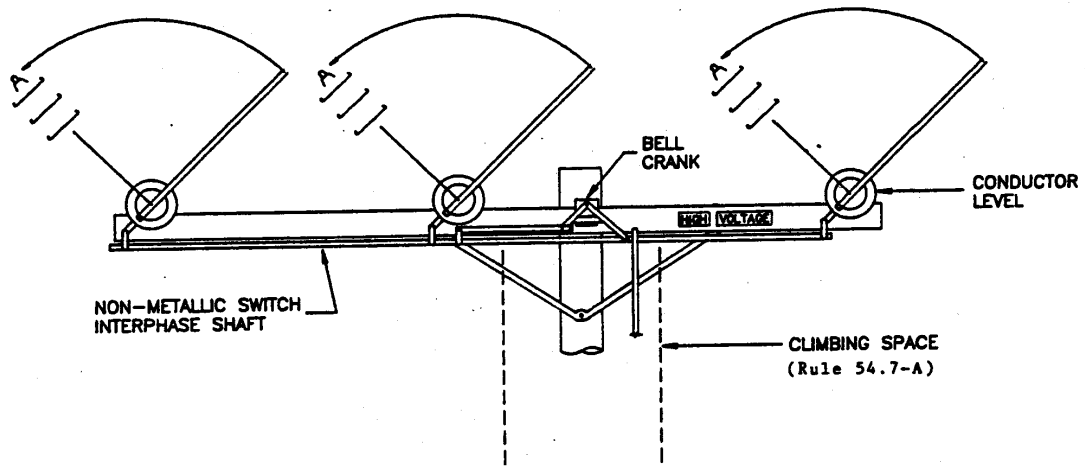

POLE TOP POSITION
CROSSARM CONSTRUCTION
Fig. 58-1

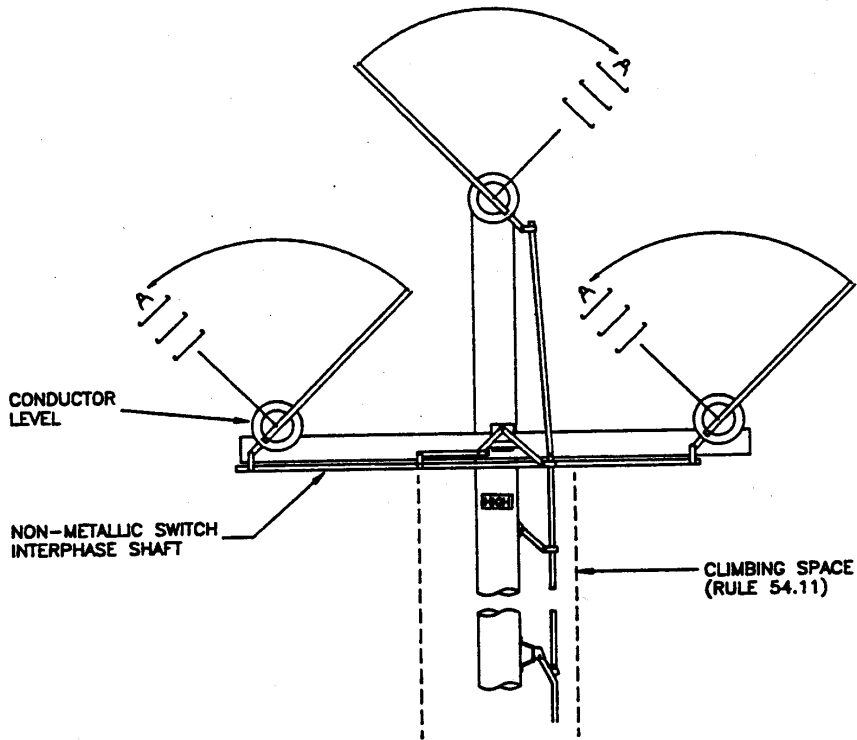

POLE TOP POSITION
BRACKET CONSTRUCTION
Fig. 58-2

RATIONALE FOR CHANGE TO RULE 58. 5-D

There are many gang operated air switches in service throughout the state, mounted in the pole top position. This proposal modifies Rule 58.5-D so it would permit certain parts of switches to be considered allowable climbing space obstructions provided they are non-metallic or if metallic not in contact with, or bonded to, hardware that can become energized through the failure of an insulator.

The design of a typical gang-operated line switch (Refer Fig. 58- 1 & 58-2) requires that an interphase shaft or rod be installed to tie the individual switch units together so they will operate in unison. This shaft or rod, as illustrated, extends laterally across the face of the pole and approximately 8 inches below the level of the line conductors deadended on each switch unit. This shaft is considered part of the switch; therefore, is not considered an allowable climbing space obstruction as presently specified in Rule 58.5-D.

The problem exists when it is necessary to install pole-mounted equipment on a pole below the switch. Presently it is necessary to install pole-mounted equipment i.e., transformers, boosters, capacitor banks, risers on the same side of the pole as the switch interphase shaft so as to avoid obstructing climbing space. In many cases there are other facilities existing on the pole that must be relocated in order to do so. This requirement as it exists, is only necessary when the switch is located below another circuit or circuits because workmen would then have to climb over the shaft or rod to gain access to the circuit(s) above.

This restriction has resulted in additional cost and inconvenience to customers because, in many cases, circuits must be de-energized so as to rearrange existing facilities to accommodate the additional equipment.

This modification of Rule 58.5-D would not impose any additional safety concerns for workers or restrict their use of climbing space.

New Lines 6-8 This provides an exception for nonmetallic horizontal interphase shafts/rods and associated isolated hardware when located at the top of the pole.

New Lines 9 & 10 The reference to voltage is removed.